

FCC PART 15B TEST REPORT  
On Behalf of  
OpenVox Communication Co., Ltd.

Digital Voice Board  
Model No.: DE430P , DE130P, DE230P

Prepared for : OpenVox Communication Co., Ltd.  
Address : F/3, Building No. 127, Jindi Industrial Zone, Futian District,  
Shenzhen, Guangdong, China

Prepared By : Anbotek Compliance Laboratory Limited  
Address : 1/F, 1/Build, SEC Industrial Park, No. 4 Qianhai Road,  
Nanshan District, Shenzhen, 518054, China  
Tel: (86) 755-2606544  
Fax: (86) 755-26014772

Report Number : 201202806F  
Date of Test : Feb. 29~Mar. 15, 2012  
Date of Report : Mar. 15, 2012

## TABLE OF CHONTENTS

Description

Page

Test Report Verification

<b>1. GENERAL INFORMATION .....</b>	<b>4</b>
1.1. Description of Device (EUT) .....	4
1.2. Auxiliary Equipment Used during Test .....	5
1.3. Description of Test Facility .....	6
1.4. Measurement Uncertainty .....	6
1.5. Test Summary .....	6
<b>2. POWER LINE CONDUCTED MEASUREMENT .....</b>	<b>7</b>
2.1. Test Equipment .....	7
2.2. Block Diagram of Test Setup .....	7
2.3. Power Line Conducted Emission Measurement Limits (FCC Part 15 Subpart B Class B) .....	7
2.4. Configuration of EUT on Measurement .....	8
2.5. Operating Condition of EUT .....	8
2.6. Test Procedure .....	8
2.7. Power Line Conducted Emission Measurement Results .....	8
<b>3. RADIATED EMISSION MEASUREMENT .....</b>	<b>11</b>
3.1. Test Equipment .....	11
3.2. Block Diagram of Test Setup .....	11
3.3. Radiated Emission Limit (Subpart B Class B) .....	13
3.4. EUT Configuration on Measurement .....	13
3.5. Operating Condition of EUT .....	13
3.6. Test Procedure .....	13
3.7. Radiated Emission Measurement Results .....	14
<b>4. PHOTOGRAPH .....</b>	<b>19</b>
4.1. Photo of Power Line Conducted Emission Test .....	19
4.2. Photo of Radiated Emission Test .....	20

APPENDIX I (Photos of EUT) (6 Pages)

# TEST REPORT VERIFICATION

Applicant : OpenVox Communication Co., Ltd.  
 Manufacturer : OpenVox Communication Co., Ltd.  
 EUT : Digital Voice Board  
 Model No. : DE430P , DE130P, DE230P  
 Rating : 3.3VDC/2.24A ,5VDC/0.1A  
 Trade Mark : N.A.

Measurement Procedure Used:

FCC Rules and Regulations Part 15 Subpart B 2010 & FCC / ANSI C63.4-2009

The device described above is tested by Anbotek Compliance Laboratory Limited To determine the maximum emission levels emanating from the device. The maximum emission levels are compared to the FCC Part 15 Subpart B Class B limits both radiated and conducted emissions. The measurement results are contained in this test report and Anbotek Compliance Laboratory Limited Is assumed full responsibility for the accuracy and completeness of these measurements. Also, this report shows that the Equipment Under Test (EUT) is to be technically compliant with the FCC requirements.

This report applies to above tested sample only. This report shall not be reproduced in part without written approval of Anbotek Compliance Laboratory Limited

Date of Test : Feb. 29~Mar. 15, 2012

Prepared by : Well Wang  
 (Engineer/ Well Wang)

Reviewer : Jerry Du  
 (Project Manager/ Jerry Du)

Approved & Authorized Signer : Henry Yang  
 (Manager/ Henry Yang)

# 1. GENERAL INFORMATION

## 1.1. Description of Device (EUT)

Description	: Digital Voice Board
Model Number	: DE430P , DE130P, DE230P (Note: The above samples are same except the model number & shape of appliances, so we prepare “DE430P” for FCC test only.)
Test Power Supply	: 3.3VDC/2.24A ,5VDC/0.1A
Applicant Address	: OpenVox Communication Co., Ltd. : F/3, Building No. 127, Jindi Industrial Zone, Futian District, Shenzhen, Guangdong, China
Manufacturer Address	: OpenVox Communication Co., Ltd. : F/3, Building No. 127, Jindi Industrial Zone, Futian District, Shenzhen, Guangdong, China
Date of Sample received	: Feb. 29, 2012
Date of Test	: Feb. 29~Mar. 15, 2012

## 1.2. Auxiliary Equipment Used during Test

PC	: Manufacturer: DELL M/N: OPTIPLEX 380 S/N: 1J63X2X CE , FCC: DOC
MONITOR	: Manufacturer: DELL M/N: E170Sc S/N: CN-00V539-64180-055-0UPS CE , FCC: DOC
KEYBOARD	: Manufacturer: DELL M/N: SK-8115 S/N: CN-0DJ313-71616-06C-02XN CE , FCC: DOC Cable: 1m, unshielded
MOUSE	: Manufacturer: DELL M/N: M-UARDEL7 S/N: N/A CE , FCC: DOC Cable: 1m, unshielded
Printer	: Manufacturer: Brother M/N: MFC-3360C S/N: N/A CE, FCC: DOC
Power Line	: 1.5m, unshielded
VGA Cable	: 1.5m, unshielded
USB Cable	: 1m, unshielded
gigabit-network Cable	: 10m, unshielded

### 1.3. Description of Test Facility

The test facility is recognized, certified, or accredited by the following organizations:

**CNAS - LAB Code: L3503**

Anbotek Compliance Laboratory Limited., Laboratory has been assessed and in compliance with CNAS/CL01: 2006 accreditation criteria for testing laboratories (identical to ISO/IEC 17025:2005 General Requirements) for the Competence of Testing Laboratories.

**FCC-Registration No.: 752021**

Anbotek Compliance Laboratory Limited, EMC Laboratory has been registered and fully described in a report filed with the (FCC) Federal Communications Commission. The acceptance letter from the FCC is maintained in our files. Registration 752021, August 20, 2010

**IC-Registration No.: 8058A-1**

Anbotek Compliance Laboratory Limited., EMC Laboratory has been registered and fully described in a report filed with the (IC) Industry Canada. The acceptance letter from the IC is maintained in our files. Registration 8058A-1, August 30, 2010

**Test Location**

All Emissions tests were performed  
 Anbotek Compliance Laboratory Limited. at 1/F, 1/Build, SEC Industrial Park,  
 No. 4 Qianhai Road, Nanshan District, Shenzhen, 518054, China

### 1.4. Measurement Uncertainty

Radiation Uncertainty : Ur = 4.3dB  
 Conduction Uncertainty : Uc = 3.4dB

### 1.5. Test Summary

For the EUT described above. The standards used were FCC Part 15 Subpart B for Emissions.

Table 1 : Tests Carried Out Under FCC Part 15 Subpart B

Standard	Test Items	Status
FCC Part 15 Subpart B	Power Line Conducted Emission Test (150KHz To 30MHz)	√
FCC Part 15 Subpart B	Radiated Emission Test	√

- √ Indicates that the test is applicable
- x Indicates that the test is not applicable

## 2. POWER LINE CONDUCTED MEASUREMENT

### 2.1. Test Equipment

The following test equipments are used during the power line conducted measurement:

Item	Equipment	Manufacturer	Model No.	Serial No.	Last Cal.	Cal. Interval
1.	EMI Receiver	Rohde & Schwarz	ESCI	100627	Nov. 12, 2011	1 Year
2.	Two-Line V-network	Rohde & Schwarz	ENV216	10055	May 19, 2011	1 Year
3.	RF Switching Unit	Compliance Direction	RSU-M2	38303	May 19, 2011	1 Year
4.	EMI Test Software	ES-K1	N/A	N/A	N/A	N/A

### 2.2. Block Diagram of Test Setup

#### 2.2.1. Block diagram of connection between the EUT and simulators

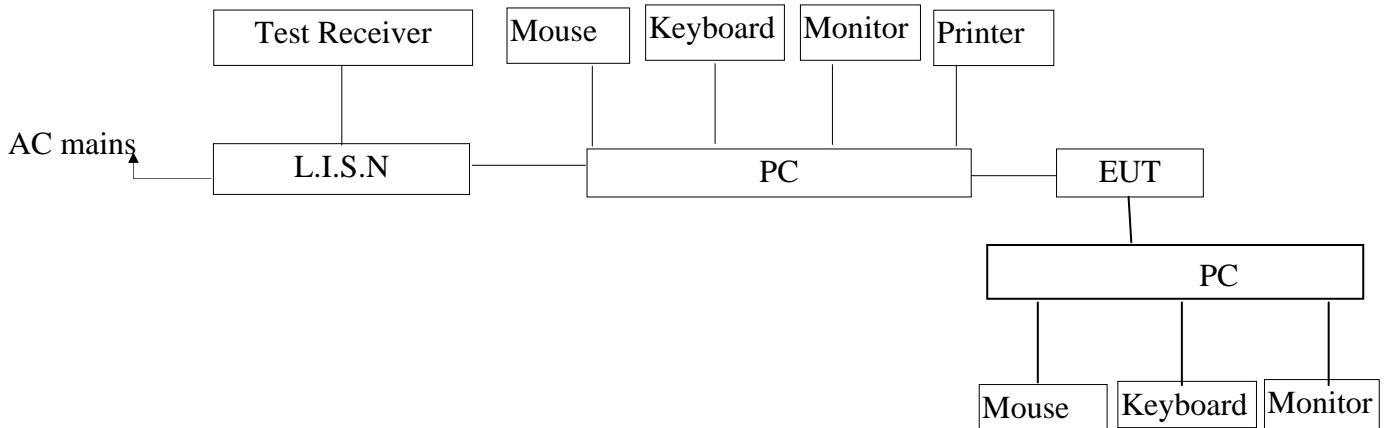

(EUT: Digital Voice Board)

### 2.3. Power Line Conducted Emission Measurement Limits (FCC Part 15

#### Subpart B Class B)

Frequency MHz	Limits dB(μV)	
	Quasi-peak Level	Average Level
0.15 ~ 0.50	66 ~ 56*	56 ~ 46*
0.50 ~ 5.00	56	46
5.00 ~ 30.00	60	50

- Notes: 1. \*Decreasing linearly with logarithm of frequency.  
2. The lower limit shall apply at the transition frequencies.

## 2.4. Configuration of EUT on Measurement

The following equipments are installed on Power Line Conducted Emission Measurement to meet the commission requirement and operating regulations in a manner which tends to maximize its emission characteristics in a normal application.

EUT : Digital Voice Board  
Model Number : DE430P  
Applicant : OpenVox Communication Co., Ltd.

## 2.5. Operating Condition of EUT

- 2.5.1. Setup the EUT and simulator as shown as Section 2.2.
- 2.5.2. Turn on the power of all equipment and running the software: asterisk.
- 2.5.3. Let the EUT work in test mode (On) and measure it.

## 2.6. Test Procedure

The EUT system is connected to the power mains through a line impedance stabilization network (L.I.S.N.). This provides a 50ohm coupling impedance for the EUT system. Please refer the block diagram of the test setup and photographs. Both sides of AC line are checked to find out the maximum conducted emission. In order to find the maximum emission levels, the relative positions of equipment and all of the interface cables shall be changed according to FCC ANSI C63.4-2009 on Conducted Emission Measurement.

The bandwidth of test receiver (ESCI) set at 9KHz.

The frequency range from 150KHz to 30MHz is checked.

The test result are reported on Section 2.7.

## 2.7. Power Line Conducted Emission Measurement Results

**PASS.**

The frequency range from 150KHz to 30 MHz is investigated.

The test curves are shown in the following pages.



**CONDUCTED EMISSION TEST DATA**

EUT: Digital Voice Board M/N: DE430P  
 Operating Condition: On  
 Test Site: 1# Shielded Room  
 Operator: WELL WANG  
 Test Specification: 120V~, 60Hz for PC  
 Comment: L  
 Tem:25°C Hum:50%

**SCAN TABLE: "Voltage (150K~30M) FIN"**  
 Short Description: 150K-30M Disturbance Voltages

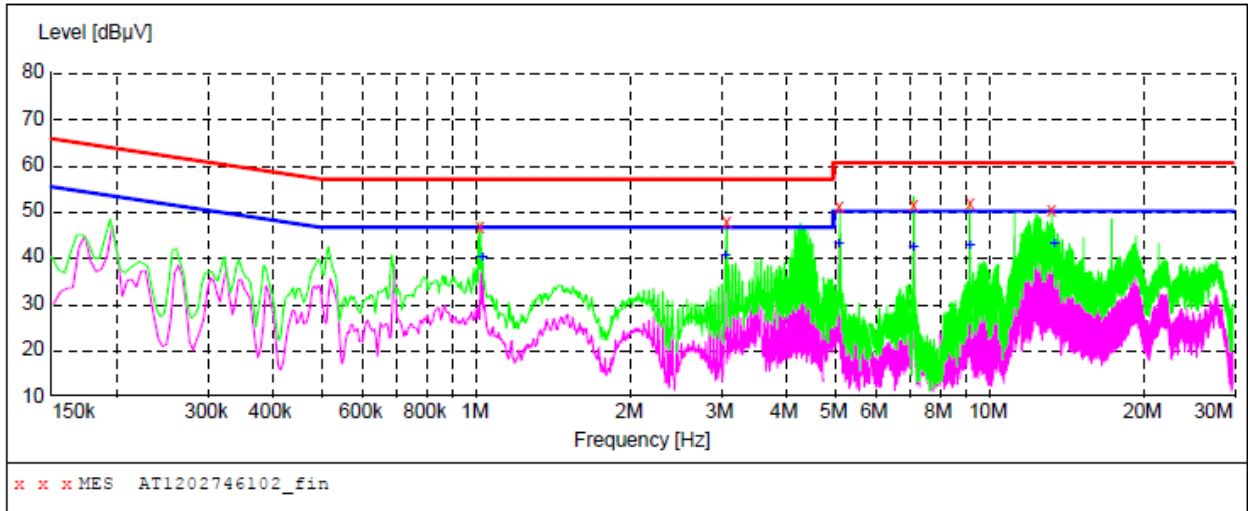

**MEASUREMENT RESULT: "AT1202746102\_fin"**

2/29/2012 11:16AM

Frequency MHz	Level dBµV	Transd dB	Limit dBµV	Margin dB	Detector	Line	PE
1.078000	45.60	10.5	56	10.4	QP	L1	GND
3.127500	46.90	10.5	56	9.1	QP	L1	GND
5.477000	51.10	10.5	60	8.9	QP	L1	GND
7.226500	50.70	10.5	60	10.3	QP	L1	GND
9.276000	50.20	10.5	60	10.8	QP	L1	GND
14.169500	49.90	10.5	60	10.1	QP	L1	GND

**MEASUREMENT RESULT: "AT1202746102\_fin2"**

2/29/2012 11:16AM

Frequency MHz	Level dBµV	Transd dB	Limit dBµV	Margin dB	Detector	Line	PE
1.033000	40.50	10.5	46	5.5	AV	L1	GND
3.078000	40.10	10.5	46	5.9	AV	L1	GND
5.127500	42.50	10.5	50	7.5	AV	L1	GND
7.177000	41.80	10.5	50	8.2	AV	L1	GND
9.226500	42.30	10.5	50	7.7	AV	L1	GND
14.276000	42.40	10.5	50	7.6	AV	L1	GND

CONDUCTED EMISSION TEST DATA

EUT: Digital Voice Board M/N:DE430P  
 Operating Condition: On  
 Test Site: 1# Shielded Room  
 Operator: WELL WANG  
 Test Specification: 120V~, 60Hz for PC  
 Comment: N  
 Tem:25°C Hum:50%

**SCAN TABLE: "Voltage(150K~30M) FIN"**  
 Short Description: 150K-30M Disturbance Voltages

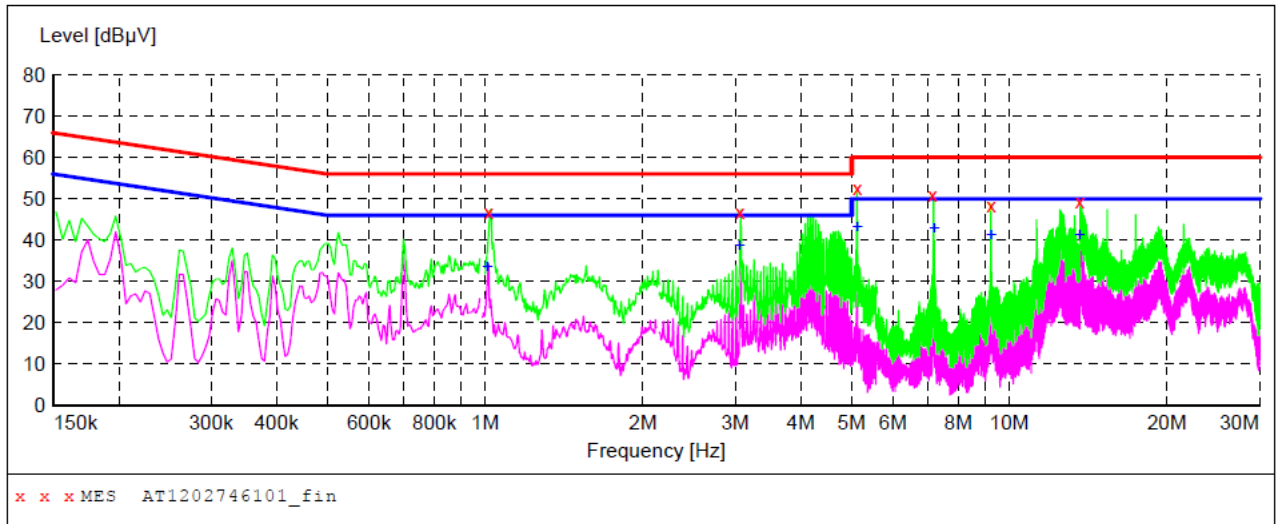

**MEASUREMENT RESULT: "AT1202746101\_fin"**

2/29/2012 11:13AM

Frequency MHz	Level dBµV	Transd dB	Limit dBµV	Margin dB	Detector	Line	PE
1.078000	46.40	10.5	56	9.6	QP	N	GND
3.127500	46.50	10.5	56	9.5	QP	N	GND
5.177000	51.90	10.5	60	8.1	QP	N	GND
7.226500	50.40	10.5	60	9.6	QP	N	GND
9.276000	48.70	10.5	60	11.3	QP	N	GND
14.169500	49.60	10.5	60	10.4	QP	N	GND

**MEASUREMENT RESULT: "AT1202746101\_fin2"**

2/29/2012 11:13AM

Frequency MHz	Level dBµV	Transd dB	Limit dBµV	Margin dB	Detector	Line	PE
1.033000	34.30	10.5	46	11.7	AV	N	GND
3.078000	38.70	10.5	46	7.3	AV	N	GND
5.127500	43.40	10.5	50	6.6	AV	N	GND
7.177000	42.70	10.5	50	7.3	AV	N	GND
9.226500	41.50	10.5	50	8.5	AV	N	GND
14.276000	40.10	10.5	50	9.9	AV	N	GND

### 3. RADIATED EMISSION MEASUREMENT

#### 3.1. Test Equipment

The following test equipments are used during the radiated emission measurement:

##### 3.1.1. For Anechoic Chamber

Item	Equipment	Manufacturer	Model No.	Serial No.	Last Cal.	Cal. Interval
1	EMI Test Receiver	Rohde & Schwarz	ESCI	100627	Nov. 12, 2011	1 Year
2	Bilog Broadband Antenna	Schwarzbeck	VULB9163	100015	May 17, 2011	1 Year
3	RF Switching Unit	Compliance Direction	RSU-M2	38303	May 19, 2011	1 Year
4	EMI Test Software	ES-K1	N/A	N/A	N/A	N/A

#### 3.2. Block Diagram of Test Setup

##### 3.2.1. Block diagram of connection between the EUT and simulators

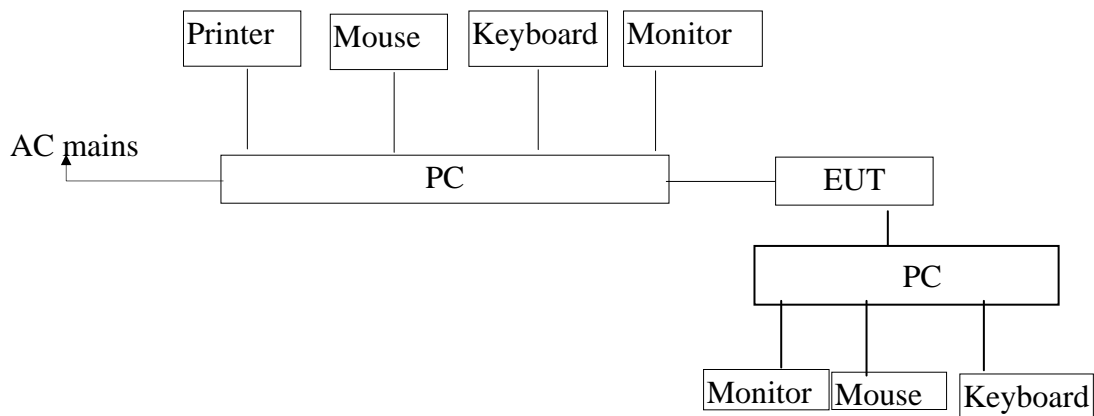

(EUT: Digital Voice Board)

### 3.2.2. Anechoic Chamber Test Setup Diagram

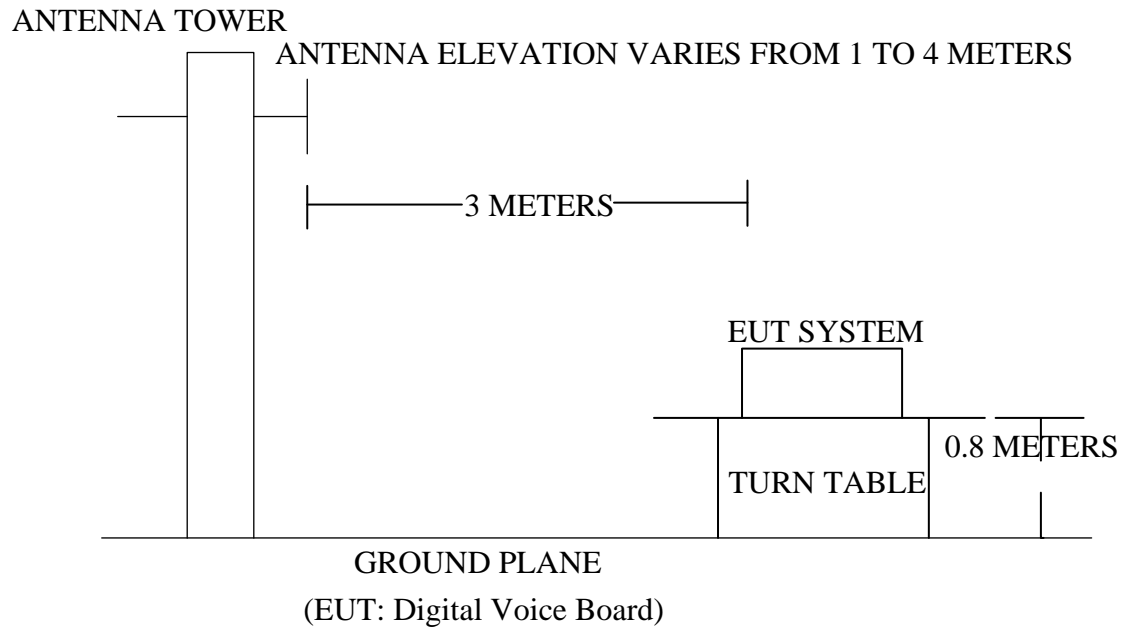

### 3.3. Radiated Emission Limit (Subpart B Class B)

FREQUENCY MHz	DISTANCE Meters	FIELD STRENGTHS LIMIT	
		$\mu\text{V}/\text{m}$	$\text{dB}(\mu\text{V})/\text{m}$
30~88	3	100	40.0
88~216	3	150	43.5
216~960	3	200	46.0
Above 960	3	500	54.0

- Remark :
- (1) Emission level  $(\text{dB})\mu\text{V} = 20 \log$  Emission level  $\mu\text{V}/\text{m}$
  - (2) The smaller limit shall apply at the cross point between two frequency bands.
  - (3) Distance is the distance in meters between the measuring instrument, antenna and the closest point of any part of the device or system.

### 3.4. EUT Configuration on Measurement

The following equipments are installed on Radiated Emission Measurement to meet the commission requirements and operating regulations in a manner which tends to maximize its emission characteristics in normal application.

EUT : Digital Voice Board  
 Model Number : DE430P  
 Applicant : OpenVox Communication Co., Ltd.

### 3.5. Operating Condition of EUT

- 3.5.1. Setup the EUT and simulator as shown as Section 3.2.
- 3.5.2. Turn on the power of all equipment and running the software: asterisk.
- 3.5.3. Let the EUT work in test mode (On) and measure it.

### 3.6. Test Procedure

EUT and its simulators are placed on a turn table, which is 0.8 meter high above ground. The turn table can rotate 360 degrees to determine the position of the maximum emission level. EUT is set 3.0 meters away from the receiving antenna, which is mounted on a antenna tower. The antenna can be moved up and down between 1.0 meter and 4 meters to find out the maximum emission level. Broadband antenna (Trilog Broadband Antenna) is used as receiving antenna. Both horizontal and vertical polarizations of the antenna are set on measurement. In order to find the maximum emission levels, all of the interface cables must be manipulated according to ANSI C63.4-2009 on radiated emission measurement.

The bandwidth of the EMI test receiver (ESCI) is set at 120kHz.

The frequency range from 30MHz to 6000MHz is checked.

The test mode (On) is tested in chamber and all the test results are listed in Section 3.7.

### 3.7. Radiated Emission Measurement Results

**PASS.**

The test curves are shown in the following pages.



**Anbotek Compliance Laboratory Limited**

1/F, 1 /Building, SEC Industrial Park, No.4 Qianhai Road,  
Nanshan District, Shenzhen, 518054, China

Tel: (86)755-26014771  
Fax: (86)755-26014772  
Http://www.anbotek.com

<b>Job No.:</b>	<b>AT1202746F</b>	<b>Polarziation:</b>	<b>Horizontal</b>
<b>Standard:</b>	<b>(RE)FCC PART15 B _3m</b>	<b>Power Source:</b>	<b>DC 3.3V</b>
<b>Test item:</b>	<b>Radiation Test</b>	<b>Date:</b>	<b>2012/03/02</b>
<b>Temp.(C)/Hum.(%RH):</b>	<b>24.3( C)/55%RH</b>	<b>Time:</b>	<b>9:20:24</b>
<b>EUT:</b>	<b>Digital Voice Board</b>	<b>Test By:</b>	<b>Well Wang</b>
<b>Model:</b>	<b>DE430P</b>	<b>Distance:</b>	<b>3m</b>

**Mode:** On

**Note:**

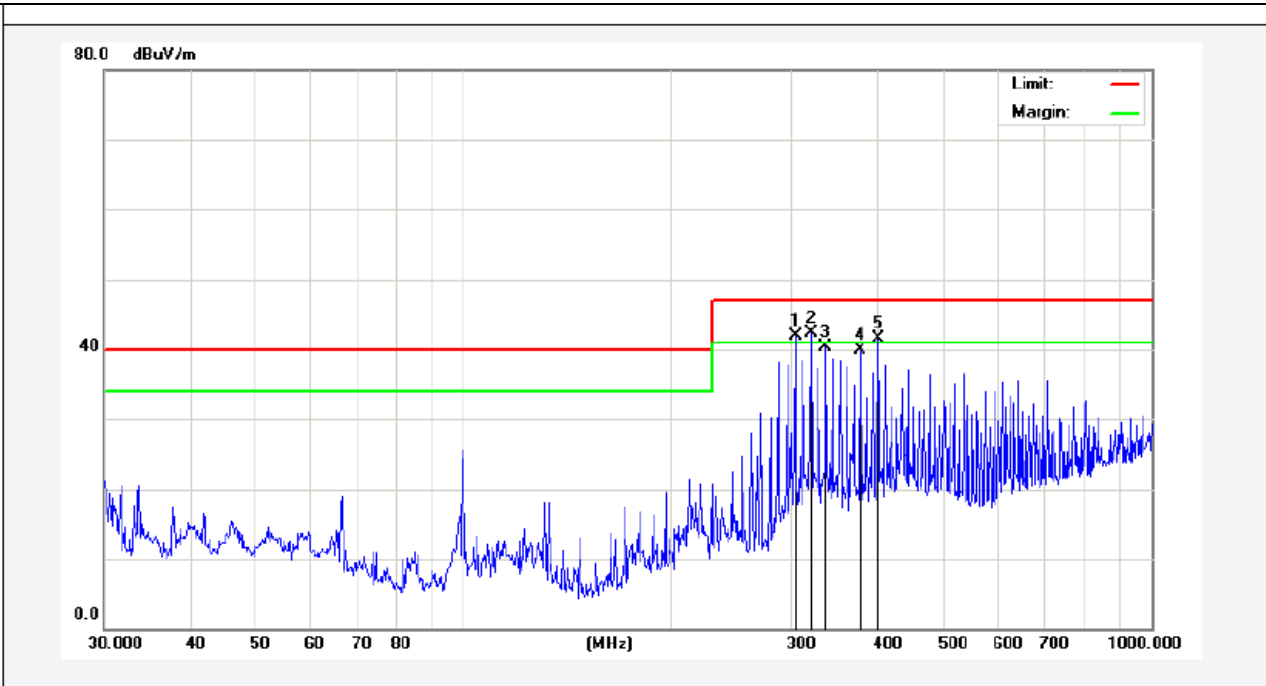

No.	Freq. (MHz)	Reading (dBuV/m)	Factor (dB/m)	Result (dBuV/m)	Limit (dBuV/)	Over Limit (dB)	Detector	Height (cm)	degree (deg)	Remark
1	303.5437	67.66	-25.75	41.91	47.00	-5.09	peak			
2	319.9370	66.10	-23.77	42.33	47.00	-4.67	peak			
3	336.0352	63.27	-23.01	40.26	47.00	-6.74	peak			
4	377.2591	61.80	-21.87	39.93	47.00	-7.07	peak			
5	400.4319	62.87	-21.43	41.44	47.00	-5.56	peak			



**Anbotek Compliance Laboratory Limited**

1/F, 1 /Building, SEC Industrial Park, No.4 Qianhai Road,  
Nanshan District, Shenzhen, 518054, China

Tel: (86)755-26014771  
Fax: (86)755-26014772  
Http://www.anbotek.com

<b>Job No.:</b>	<b>AT1202746F</b>	<b>Polarziation:</b>	<b>Vertical</b>
<b>Standard:</b>	<b>(RE)FCC PART15 B _3m</b>	<b>Power Source:</b>	<b>DC 3.3V</b>
<b>Test item:</b>	<b>Radiation Test</b>	<b>Date:</b>	<b>2012/03/02</b>
<b>Temp.(C)/Hum.(%RH):</b>	<b>24.3( C)/55%RH</b>	<b>Time:</b>	<b>9:22:39</b>
<b>EUT:</b>	<b>Digital Voice Board</b>	<b>Test By:</b>	<b>Well Wang</b>
<b>Model:</b>	<b>DE430P</b>	<b>Distance:</b>	<b>3m</b>

**Mode:** On

**Note:**

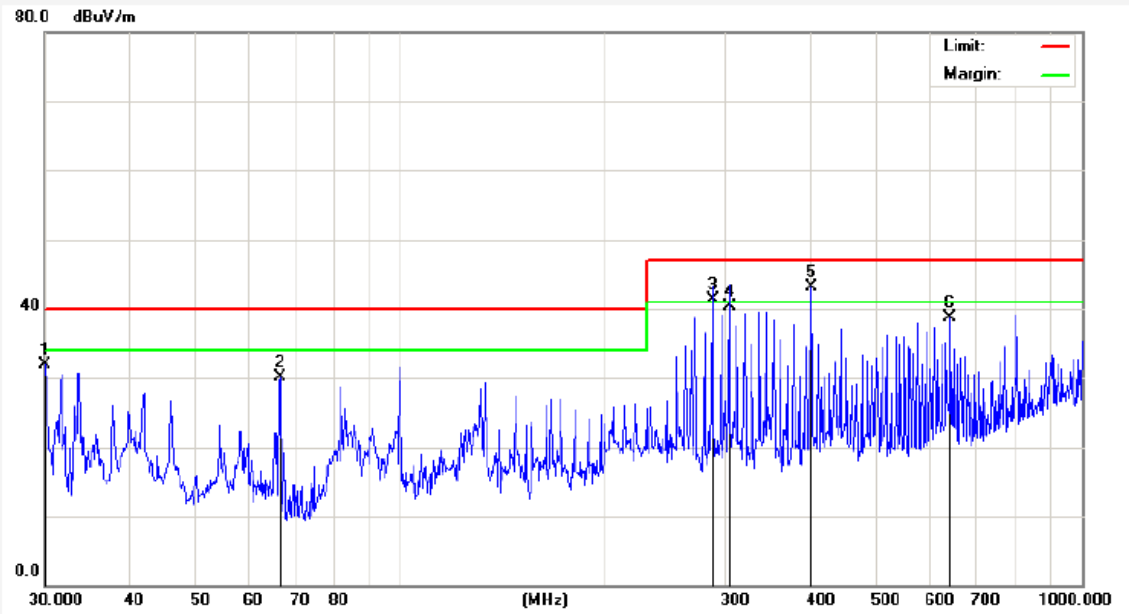

No.	Freq. (MHz)	Reading (dBuV/m)	Factor (dB/m)	Result (dBuV/m)	Limit (dBuV/)	Over Limit (dB)	Detector	Height (cm)	degree (deg)	Remark
1	30.1053	58.24	-26.32	31.92	40.00	-8.08	peak			
2	66.4989	57.96	-27.94	30.02	40.00	-9.98	peak			
3	286.7123	64.83	-23.54	41.29	47.00	-5.71	QP	100	360	
4	303.1137	63.51	-23.12	40.39	47.00	-6.61	QP	100	0	
5	399.9418	63.52	-20.44	43.08	47.00	-3.92	QP	100	0	
6	640.6109	54.86	-16.15	38.71	47.00	-8.29	peak			





**Anbotek Compliance Laboratory Limited**

1/F, 1 /Building, SEC Industrial Park, No.4 Qianhai Road,  
Nanshan District, Shenzhen, 518054, China

Tel: (86)755-26014771  
Fax: (86)755-26014772  
Http://www.anbotek.com

<b>Job No.:</b>	<b>AT1202746F</b>	<b>Polarziation:</b>	<b>Horizontal</b>
<b>Standard:</b>	<b>(RE)FCC PART15 B _3m</b>	<b>Power Source:</b>	<b>DC 3.3V</b>
<b>Test item:</b>	<b>Radiation Test</b>	<b>Date:</b>	<b>2012/03/02</b>
<b>Temp.(C)/Hum.(%RH):</b>	<b>24.3( C)/55%RH</b>	<b>Time:</b>	<b>9:29:58</b>
<b>EUT:</b>	<b>Digital Voice Board</b>	<b>Test By:</b>	<b>Well Wang</b>
<b>Model:</b>	<b>DE430P</b>	<b>Distance:</b>	<b>3m</b>

**Mode:** On

**Note:**

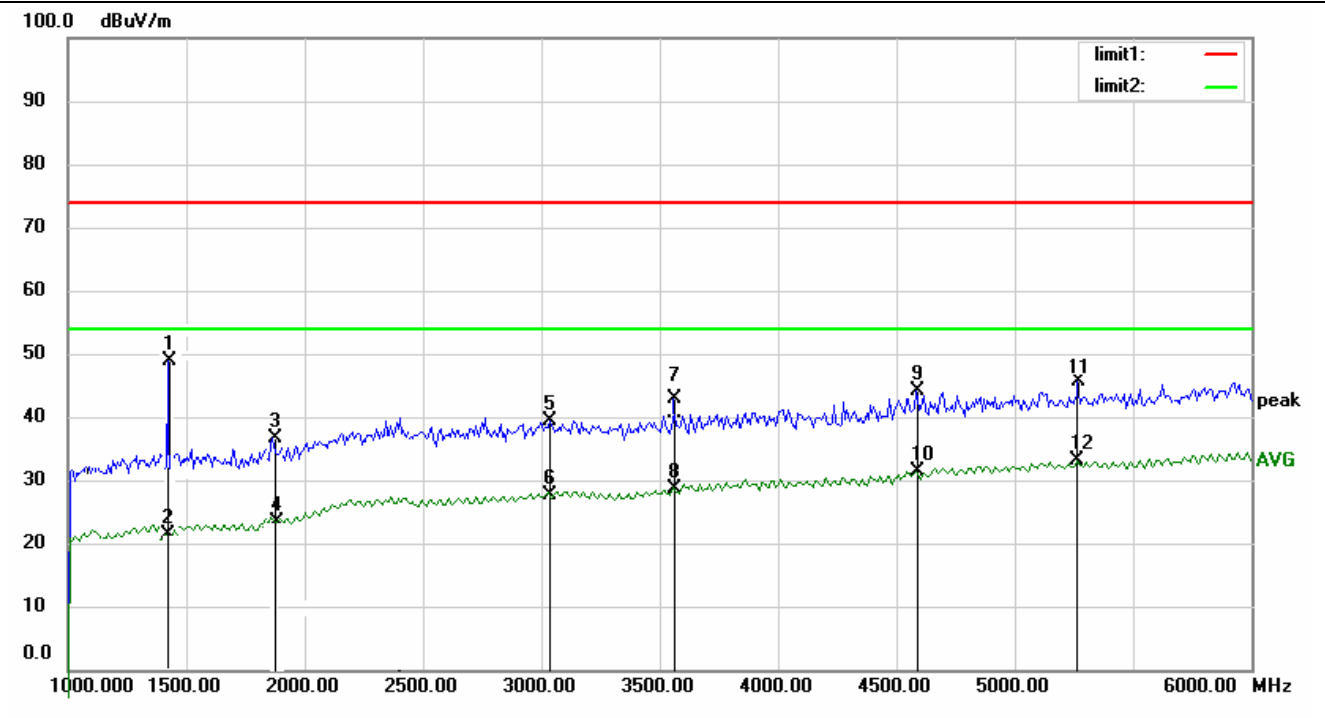

No. Mk.	Freq. MHz	Reading Level dBuV	Correct Factor dB	Measurement dBuV/m	Limit dBuV/m	Over dB	Detector
1	1416.289	51.27	-8.73	42.08	74.00	-31.92	peak
2	1416.289	37.40	-8.73	28.63	54.00	-25.37	AVG
3	1883.159	46.60	-8.16	38.44	74.00	-35.56	peak
4	1883.159	34.12	-8.16	25.96	54.00	-28.04	AVG
5	3037.467	47.57	-7.24	40.33	74.00	-33.67	peak
6	3037.467	36.24	-7.24	29.00	54.00	-25.00	AVG
7	3571.762	48.00	-6.54	41.46	74.00	-32.54	peak
8	3571.762	36.41	-6.54	29.87	54.00	-24.13	AVG
9	4580.579	47.25	-4.97	42.28	74.00	-31.72	peak
10	4580.579	36.19	-4.97	31.22	54.00	-22.78	AVG
11	5264.274	48.10	-3.17	44.83	74.00	-29.17	peak
12	5264.274	36.28	-3.17	33.11	54.00	-20.89	AVG



**Anbotek Compliance Laboratory Limited**

1/F, 1 /Building, SEC Industrial Park, No.4 Qianhai Road,  
Nanshan District, Shenzhen, 518054, China

Tel: (86)755-26014771  
Fax: (86)755-26014772  
Http://www.anbotek.com

<b>Job No.:</b>	AT1202746F	<b>Polarziation:</b>	Vertical
<b>Standard:</b>	(RE)FCC PART15 B _3m	<b>Power Source:</b>	DC 3.3V
<b>Test item:</b>	Radiation Test	<b>Date:</b>	2012/03/02
<b>Temp.(C)/Hum.(%RH):</b>	24.3( C)/55%RH	<b>Time:</b>	9:32:20
<b>EUT:</b>	Digital Voice Board	<b>Test By:</b>	Well Wang
<b>Model:</b>	DE430P	<b>Distance:</b>	3m
<b>Mode:</b>	On		

**Note:**

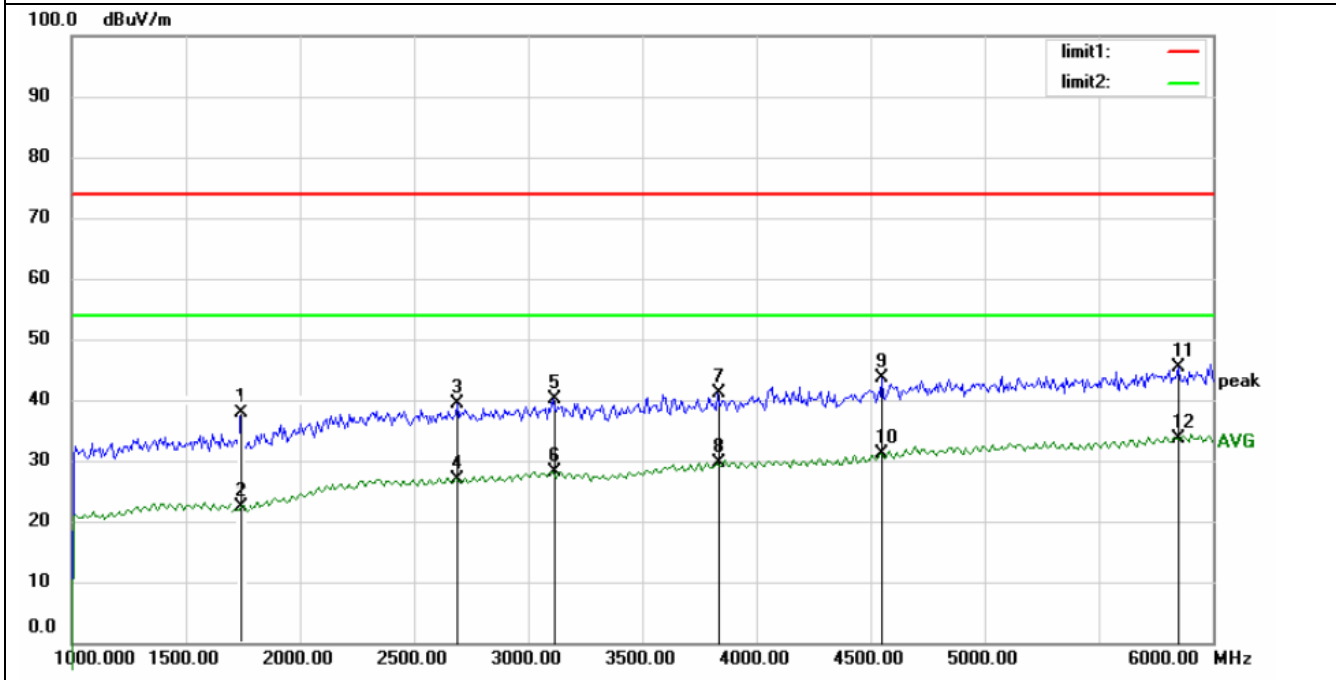

No. Mk.	Freq. MHz	Reading Level dBuV	Correct Factor dB	Measurement dBuV/m	Limit dBuV/m	Over dB	Detector
1	1756.231	49.27	-8.73	40.05	74.00	-33.95	peak
2	1756.231	35.46	-8.73	26.73	54.00	-27.27	AVG
3	2683.553	49.60	-8.16	41.44	74.00	-32.56	peak
4	2683.553	34.12	-8.16	25.96	54.00	-28.04	AVG
5	3110.357	49.61	-7.24	42.37	74.00	-31.63	peak
6	3110.357	38.24	-7.24	31.00	54.00	-23.00	AVG
7	3831.761	49.90	-6.54	43.36	74.00	-30.64	peak
8	3831.761	37.41	-6.54	30.87	54.00	-23.13	AVG
9	4540.521	47.25	-4.97	42.28	74.00	-31.72	peak
10	4540.521	36.20	-4.97	31.23	54.00	-22.77	AVG
11	5854.248	48.02	-3.17	44.85	74.00	-29.15	peak
12	5854.248	36.18	-3.17	33.01	54.00	-20.99	AVG