

FCC PART 15.247

MEASUREMENT AND TEST REPORT

For

Wi2Wi, Inc.

2107 N. First Street, Ste. 540
San Jose, CA 95131

FCCID: U9R-W2CBW003
Model: W2CBW003

Report Type: <input checked="" type="checkbox"/> Original Report		Product Type: 802.11b/g +Bluetooth Module	
Test Engineer(s):	James Ma <i>James Ma</i>		
Report Number:	R0703307-247 BT		
Report Date:	2007-05-02		
Reviewed By:	RF Engineering Lead: Daniel Deng <i>Daniel</i>		
Prepared By: (ct)	Bay Area Compliance Laboratories Corp. 1274 Anvilwood Ave. Sunnyvale, CA 94089, USA Tel: (408) 732-9162 Fax: (408) 732-9164		

Note: This test report is for the customer shown above and their specific product only. It may not be duplicated or used in part without prior written consent from Bay Area Compliance Laboratories Corp. This report **must not** be used by the customer to claim product certification, approval, or endorsement by NVLAP, NIST, or any agency of the Federal Government.

TABLE OF CONTENTS

1 GENERAL INFORMATION4

1.1 PRODUCT DESCRIPTION FOR EQUIPMENT UNDER TEST (EUT)4

1.2 MECHANICAL DESCRIPTION OF EUT4

1.3 ANTENNA DESCRIPTION4

1.4 EUT PHOTOGRAPH5

1.5 OBJECTIVE5

1.6 RELATED SUBMITTAL(S)/GRANT(S).....5

1.7 TEST METHODOLOGY5

1.8 MEASUREMENT UNCERTAINTY5

1.9 TEST FACILITY6

2 SYSTEM TEST CONFIGURATION7

2.1 JUSTIFICATION7

2.2 EUT EXERCISE SOFTWARE7

2.3 SPECIAL ACCESSORIES7

2.4 EQUIPMENT MODIFICATIONS7

2.5 LOCAL SUPPORT EQUIPMENT7

2.6 INTERFACE PORTS AND CABLES7

3 SUMMARY OF TEST RESULTS FOR FCC PART 158

4 §15.203 - ANTENNA REQUIREMENT9

4.1 APPLICABLE STANDARD9

4.2 RESULT9

5 §15.207 – CONDUCTED EMISSIONS10

5.1 APPLICABLE STANDARD10

5.2 TEST SETUP10

5.3 TEST EQUIPMENT LIST AND DETAILS10

5.4 TEST PROCEDURE10

5.5 TEST SETUP DIAGRAM11

5.6 ENVIRONMENTAL CONDITIONS11

5.7 SUMMARY OF TEST RESULTS11

5.8 CONDUCTED EMISSIONS TEST PLOT & DATA12

6 §15.205, §15.209(a) & §15.247(d) - RADIATED EMISSIONS14

6.1 APPLICABLE STANDARD: FCC §15.205 (A).....14

6.2 APPLICABLE STANDARD: FCC §15.209 RADIATED EMISSION LIMITS, GENERAL REQUIREMENTS14

6.3 TEST SETUP15

6.4 TEST EQUIPMENT LIST AND DETAILS15

6.5 ENVIRONMENTAL CONDITIONS15

6.6 TEST PROCEDURE16

6.7 CORRECTED AMPLITUDE & MARGIN CALCULATION16

6.8 SUMMARY OF TEST RESULTS16

6.9 RADIATED SPURIOUS EMISSIONS TEST DATA17

7 §15.247 (D) SPURIOUS EMISSIONS AT ANTENNA TERMINALS19

7.1 APPLICABLE STANDARD19

7.2 MEASUREMENT PROCEDURE19

7.3 TEST EQUIPMENT19

7.4 TEST SETUP DIAGRAM19

7.5 ENVIRONMENTAL CONDITIONS19

7.6 MEASUREMENT RESULTS20

8 §15.247 (a) (1) - HOPPING CHANNEL SEPARATION26

8.1 APPLICABLE STANDARD26

8.2 MEASUREMENT PROCEDURE26

8.3 TEST EQUIPMENT26

8.4	TEST SETUP DIAGRAM	26
8.5	ENVIRONMENTAL CONDITIONS	27
8.6	MEASUREMENT RESULTS	27
9	§15.247 (a) (1) – HOPPING CHANNEL BANDWIDTH.....	29
9.1	STANDARD APPLICABLE	29
9.2	MEASUREMENT PROCEDURE	29
9.3	TEST EQUIPMENT LIST AND DETAILS	29
9.4	TEST SETUP DIAGRAM	30
9.5	ENVIRONMENTAL CONDITIONS	30
9.6	MEASUREMENT RESULTS	30
9.7	MEASUREMENT TEST RESULT	31
10	§15.247 (a) (1) (iii) - NUMBER OF HOPPING FREQUENCIES USED	33
10.1	STANDARD APPLICABLE	33
10.2	MEASUREMENT PROCEDURE	33
10.3	TEST EQUIPMENT LIST AND DETAILS	33
10.4	TEST SETUP DIAGRAM	33
10.5	ENVIRONMENTAL CONDITIONS	33
10.6	MEASUREMENT RESULT	34
11	§15.247(a) (1) (iii) - DWELL TIME.....	36
11.1	APPLICABLE STANDARD.....	36
11.2	MEASUREMENT PROCEDURE	36
11.3	TEST EQUIPMENT LIST AND DETAILS	36
11.4	TEST SETUP DIAGRAM	36
11.5	MEASUREMENT RESULTS	37
12	§15.247(B) (2) - MAXIMUM PEAK OUTPUT POWER	41
12.1	STANDARD APPLICABLE.....	41
12.2	MEASUREMENT PROCEDURE	41
12.3	TEST EQUIPMENT LIST AND DETAILS	41
12.4	TEST SETUP DIAGRAM	41
12.5	MEASUREMENT RESULT	41
13	§15.247 (d) - 100 KHz BANDWIDTH OF BAND EDGES.....	44
13.1	APPLICABLE STANDARD.....	44
13.2	MEASUREMENT PROCEDURE	44
13.3	TEST EQUIPMENT LIST AND DETAILS	44
13.4	TEST SETUP DIAGRAM	44
13.5	PLOTS OF 100 KHz BANDWIDTH OF BAND EDGE.....	45

1 GENERAL INFORMATION

1.1 Product Description for Equipment Under Test (EUT)

The *Wi2Wi, Inc.* product, *FCC ID: U9R-W2CBW003*, *model: W2CBW003*, or the “EUT” as referred to in this report, is a 802.11b/g + Bluetooth module. Unlike a typical module the W2CBW003 includes all radio components, clocking and regulation for a complete WLAN radio subsystem. It also included in the solution is Wi2Wi's coexistence solution for simultaneous operation of Wi-Fi and Bluetooth Radios.

The small, compact, low power design is targeted specifically for the developers of portable electronics such as MP3/MP4 players, PDAs and Smart Phones. The W2CBW003 features one of the smallest footprints in the industry and provides the interfaces commonly required by handheld/portable devices. The W2CBW003 offers a single module integration of Wi-Fi and Bluetooth functionality into end-user products.

The transceiver uses 78 channels for frequency hopping in the 2402 to 2480 MHz band. The lowest channel is centered at 2402 MHz and the highest channel is centered at 2480 MHz.

The transceiver uses OFDM and CCK modulation for the 802.11b/g module; GFSK, $\pi/4$ DQPSK, 8DPSK modulation for the Bluetooth module.

1.2 Mechanical Description of EUT

The *Wi2Wi, Inc.* product, *FCC ID: U9R-W2CBW003*, *model: W2CBW003*, measures approximately 12 mmL x 12 mmW x 1.4 mmH, and weighs approximately 1 g.

**The test data gathered are from production sample, serial number: 07110114, provided by the manufacturer.*

1.3 Antenna Description

The antenna used is portable, center fed, whip antenna. It is a coaxial sleeve design with an omni-directional pattern.

Item Number	Model/Type	
Antenna 1.	Model number:	HG2403RD-RSF
	Manufacturer:	HyperLink Technologies, Inc.
	Frequency Range:	2400-2500 MHz
	Connector Type/ Maximum Gain	Reverse Polarity SMA Plug/ 3 dBi
	Antenna Type/ Pattern:	Monopole/omni-directional
	Measurement:	Length: 13 mmD x 137 mmL; Weight: 23 g

1.4 EUT Photograph

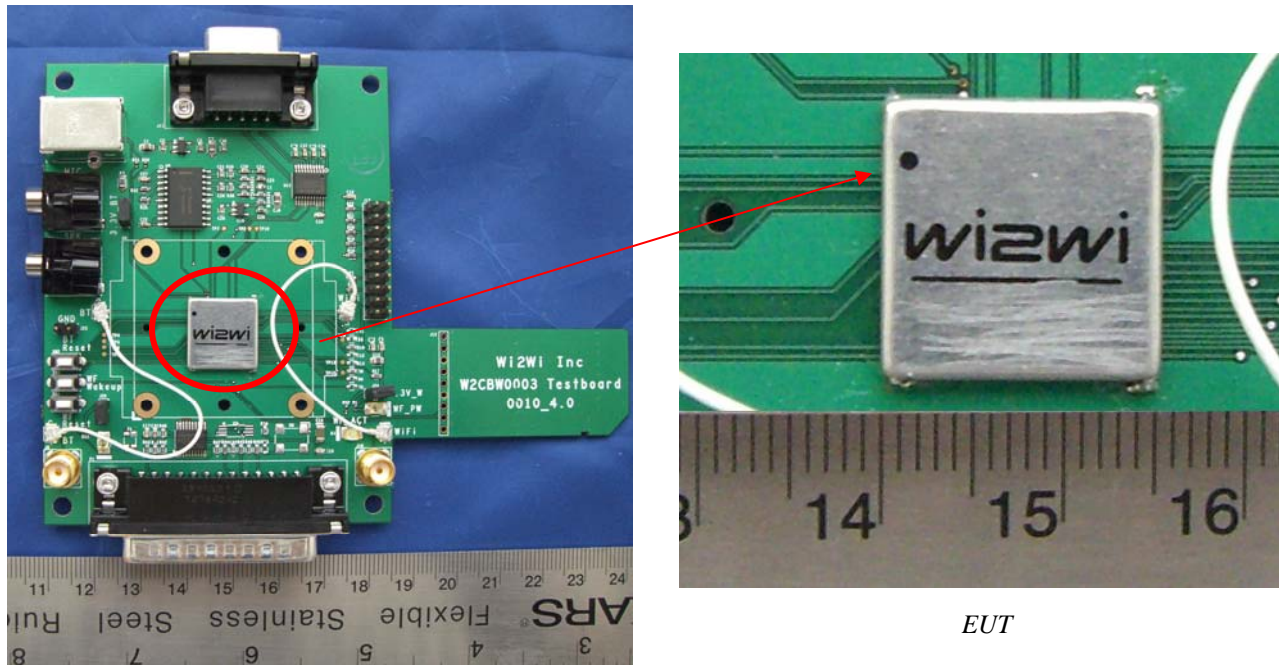

EUT built in the support board

Please refer to Exhibit C for more EUT photographs.

1.5 Objective

This type approval report is prepared on behalf of *Wi2Wi, Inc.* in accordance with Part 2, Subpart J, Part 15, Subparts A, B, and C of the Federal Communication Commissions rules.

The objective is to determine compliance with FCC 15.247 Standard's limits rules for Antenna Requirements, Conducted Emissions, Radiated Emissions, Spurious Emissions at Antenna Port, Hopping Channel Separation, Hopping Channel Bandwidth, Number of Hopping Frequencies Used, Dwell Time of Each Frequency, Maximum Peak Output Power, 100 kHz Bandwidth of Frequency Band Edge and RF Exposure.

1.6 Related Submittal(s)/Grant(s)

Please refer to Bay Area Compliance Laboratories Corp's report number: R0703307-247 802.11 (*FCC ID: U9R-W2CBW003*) for 802.11 b/g test results.

1.7 Test Methodology

All measurements contained in this report were conducted in accordance with ANSI C63.4-2003.

1.8 Measurement Uncertainty

All measurements involve certain levels of uncertainties, especially in the field of EMC. The factors contributing to uncertainties are spectrum analyzer, cable loss, antenna factor calibration, antenna directivity, antenna factor variation with height, antenna phase center variation, antenna factor frequency

interpolation, measurement distance variation, site imperfections, mismatch (average), and system repeatability.

Based on NIS 81, The Treatment of Uncertainty in EMC Measurements, the values ranging from ± 2.0 dB for Conducted Emissions tests and ± 4.0 dB for Radiated Emissions tests are the most accurate estimates pertaining to uncertainty of EMC measurements at BACL Corp.

Detailed instrumentation measurement uncertainties can be found in BACL Corp. report QAP-018.

1.9 Test Facility

The test site used by BACL Corp. to collect radiated and conducted emissions measurement data is located at its facility in Sunnyvale, California, USA.

The test site at BACL Corp. has been fully described in reports submitted to the Federal Communication Commission (FCC) and Voluntary Control Council for Interference (VCCI). The details of these reports have been found to be in compliance with the requirements of Section 2.948 of the FCC Rules on February 11, 1997 and December 10, 1997 and Article 8 of the VCCI regulations on December 25, 1997. The facility also complies with the test methods and procedures set forth in ANSI C63.4-2003 & TIA/EIA-603.

The Federal Communications Commission and Voluntary Control Council for Interference have the reports on file and they are listed under FCC registration number: 90464 and VCCI Registration Number: R-2463 and C-2698. The test site has been approved by the FCC and VCCI for public use and is listed in the FCC Public Access Link (PAL) database.

Additionally, BACL Corp. is a National Institute of Standards and Technology (NIST) accredited laboratory under the National Voluntary Laboratory Accredited Program (Lab Code 200167-0). The current scope of accreditations can be found at <http://ts.nist.gov/ts/hdocs/210/214/scopes/2001670.htm>.

2 SYSTEM TEST CONFIGURATION

2.1 Justification

The EUT was configured for testing according to ANSI C63.4-2003.

The EUT was tested in the normal (native) operating mode to represent *worst*-case results during the final qualification test.

2.2 EUT Exercise Software

The software is provided by customer. The EUT exercise program used during radiated testing was designed to exercise the system components.

2.3 Special Accessories

N/A

2.4 Equipment Modifications

No modifications were made to the EUT.

2.5 Local Support Equipment

Manufacturer	Description	Model	Serial Number
Toshiba	Laptop	Satellite R15-S829	Y5040228H
Toshiba	AC/DC Adapter	PA3282U-1ACA	G71C0002SB10

2.6 Interface Ports and Cables

Cable Description	Length (M)	From	To
USB Cable	1.5	EUT	Laptop

3 SUMMARY OF TEST RESULTS FOR FCC PART 15

FCC RULES	DESCRIPTION OF TEST	RESULT
§15.203	Antenna Requirement	Compliant
§ 15.207 (a)	Conducted Emissions	Compliant
§15.205, §15.209 & §15.247(d)	Radiated Emissions	Compliant
§15.247(d)	Spurious Emissions at Antenna Terminals	Compliant
§15.247 (a) (1)	Hopping Channel Separation	Compliant
§15.247 (a) (1)	Channel Bandwidth	Compliant
§15.247 (a) (1) (iii)	Number of Hopping Frequencies Used	Compliant
§15.247 (a) (1) (i)	Dwell Time of Each Frequency	Compliant
§15.247 (b)(1)	Maximum Peak Output Power	Compliant
§ 15.247 (d)	100 kHz Bandwidth of Frequency Band Edge	Compliant
§15.247(e)(i) §2.1091	RF Exposure	Compliant

4 §15.203 - ANTENNA REQUIREMENT

4.1 Applicable Standard

According to § 15.203, an intentional radiator shall be designed to ensure that no antenna other than that furnished by the responsible party shall be used with the device. The use of a permanently attached antenna or of an antenna that uses a unique coupling to the intentional radiator shall be considered sufficient to comply with the provisions of this Section. The manufacturer may design the unit so that a broken antenna can be replaced by the user, but the use of a standard antenna jack or electrical connector is prohibited.

And according to § 15.247 (b) (4), if transmitting antennas of directional gain greater than 6 dBi are used the power shall be reduced by the amount in dB that the directional gain of the antenna exceeds 6 dBi.

4.2 Result

The antenna, model: HG2403RD-RSF for this device is a center fed monopole whip antennae with a maximum gain of 3 dBi that uses a reverse polarity SMA connector thus complying with the 15.203 unique coupling requirement.

Compliant

N/A

Please refer to the following antenna photo for details.



Antenna photo

5 §15.207 – CONDUCTED EMISSIONS

5.1 Applicable Standard

According to FCC §15.207 (a) Except as shown in paragraphs (b) and (c) of this section, for an intentional radiator that is designed to be connected to the public utility (AC) power line, the radio frequency voltage that is conducted back onto the AC power line on any frequency or frequencies within the band 150 kHz to 30 MHz shall not exceed the limits in the following table, as measured using a 50 μ H/50 ohms line impedance stabilization network (LISN). Compliance with the provisions of this paragraph shall be based on the measurement of the radio frequency voltage between each power line and ground at the power terminal. The lower limit applies at the boundary between the frequencies ranges.

Frequency Range (MHz)	Conducted limit (dB μ V)	
	Quasi-peak	Average
0.15-0.5	66 to 56*	56 to 46*
0.5-5	56	46
5-30	60	50

**Decreases with the logarithm of the frequency*

5.2 Test Setup

The measurement was performed at shield room, using the setup per ANSI C63.4 – 2003 measurement procedure. The specification used was FCC Class B limits.

External I/O cables were draped along the edge of the test table and bundle when necessary.

The laptop was connected with LISN-1.

5.3 Test Equipment List and Details

Manufacturer	Description	Model	Serial Number	Calibration Date
Rohde & Schwarz	EMI Test Receiver	ESCI 1166.5950K03	100337	2007-03-08
Rohde & Schwarz	LISN, Artificial Mains	ESH2-Z5	871884/039	2006-11-12

*** Statement of Traceability: BACL Corp.** attests that all calibrations have been performed per the NVLAP requirements, traceable to the NIST.

5.4 Test Procedure

During the conducted emissions test, the power cord of adaptor was connected to the mains outlet of the LISN-1.

Maximizing procedure was performed on the six (6) highest emissions of the EUT. All data was recorded in the peak detection mode, quasi-peak and average. Quasi-Peak readings are distinguished with a “QP”. Average readings are distinguished with an “Ave”.

5.5 Test Setup Diagram

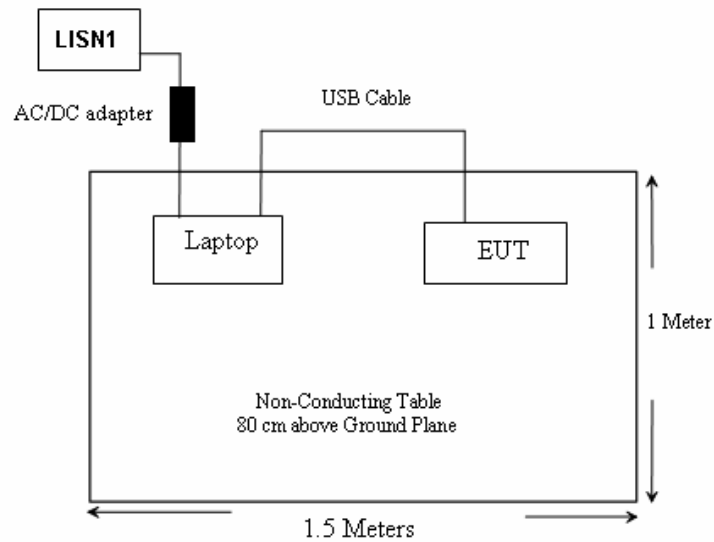

5.6 Environmental Conditions

Temperature:	23 °C
Relative Humidity:	40 %
ATM Pressure:	102.0 kPa

* The testing was performed by James Ma on 2007-05-31.

5.7 Summary of Test Results

According to the recorded data in following table, the EUT complied with the FCC standard's conducted emissions limits for Class B devices, with the *worst* margin reading of:

-13.8 dB at 1.778000 MHz in the Hot Conductor

Please refer to the following plots and tables for complete test results

5.8 Conducted Emissions Test plot & data

120V/60Hz Hot Conductor

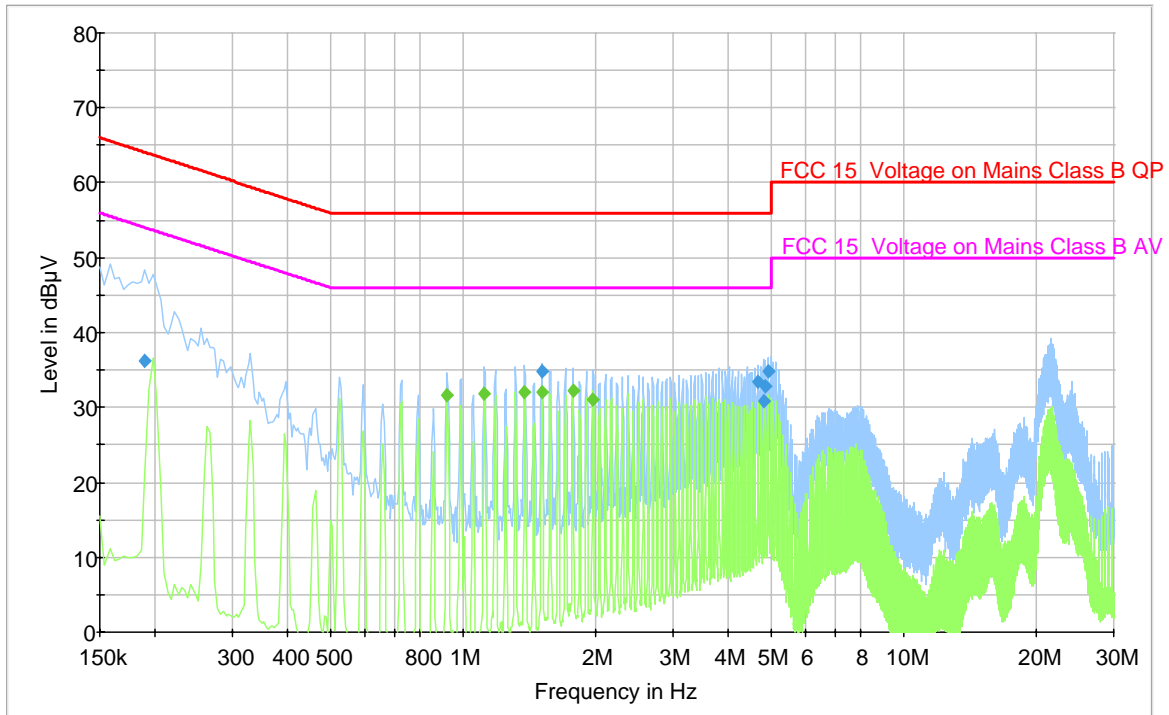

QP Measurements

Frequency (MHz)	Quasi-Peak (dBµV)	Conductor (H/N)	Limit (dBµV)	Margin (dB)
1.514000	34.8	H	56.0	-21.2
4.938000	34.8	H	56.0	-21.2
4.674000	33.4	H	56.0	-22.6
4.870000	32.8	H	56.0	-23.2
4.802000	30.8	H	56.0	-25.2
0.190000	36.3	H	64.0	-27.8

Average Measurements

Frequency (MHz)	Average (dBµV)	Conductor (H/N)	Limit (dBµV)	Margin (dB)
1.778000	32.2	H	46.0	-13.8
1.514000	32.1	H	46.0	-13.9
1.382000	32.0	H	46.0	-14.0
1.118000	31.8	H	46.0	-14.2
0.922000	31.7	H	46.0	-14.3
1.974000	31.0	H	46.0	-15.0

120V/60Hz, Neutral Conductor

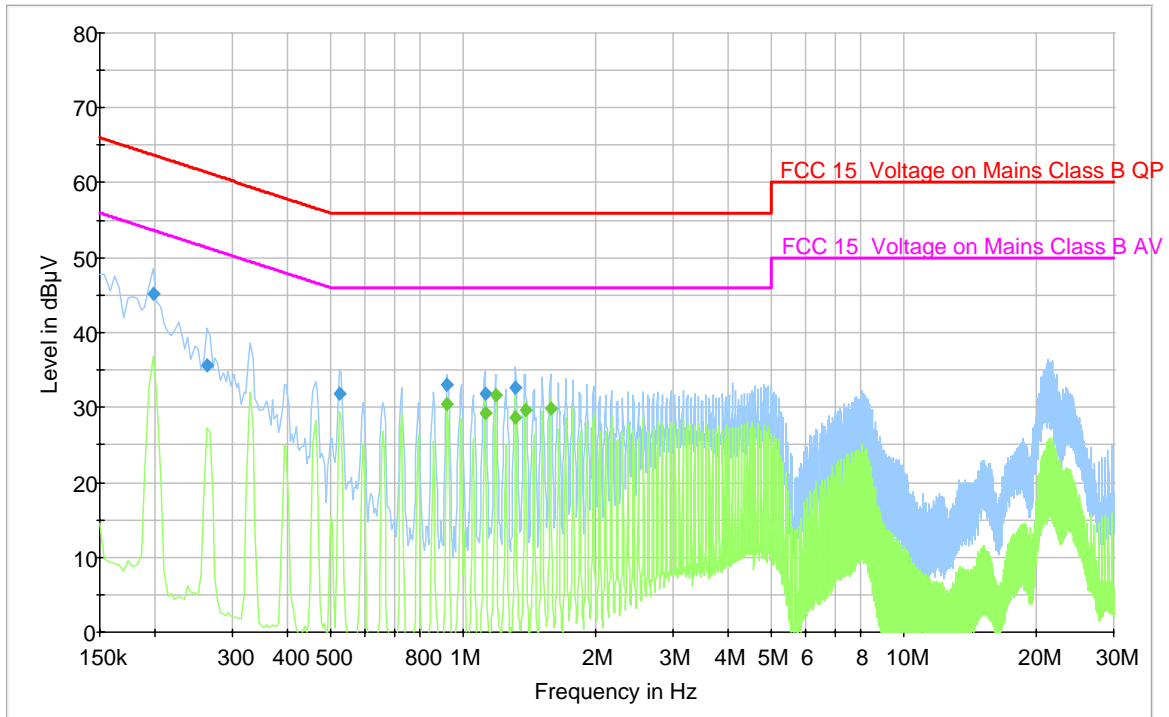

QP Measurements

Frequency (MHz)	Quasi-Peak (dBµV)	Conductor (H/N)	Limit (dBµV)	Margin (dB)
0.198000	45.1	N	63.7	-18.6
0.922000	33.1	N	56.0	-22.9
1.318000	32.6	N	56.0	-23.4
0.526000	31.9	N	56.0	-24.1
1.122000	31.9	N	56.0	-24.1
0.262000	35.6	N	61.4	-25.8

Average Measurements

Frequency (MHz)	Average (dBµV)	Conductor (H/N)	Limit (dBµV)	Margin (dB)
1.186000	31.7	N	46.0	-14.3
0.922000	30.5	N	46.0	-15.5
1.582000	29.8	N	46.0	-16.2
1.386000	29.6	N	46.0	-16.4
1.122000	29.2	N	46.0	-16.8
1.318000	28.7	N	46.0	-17.3

6 §15.205, §15.209(a) & §15.247(d) - RADIATED EMISSIONS

6.1 Applicable Standard: FCC §15.205 (a)

a) As Per 15.205(a) except as show in paragraph (d) of this section, only spurious emissions are permitted in any of the frequency bands listed below:

MHz	MHz	MHz	GHz
0.090 – 0.110	16.42 – 16.423	960 – 1240	4.5 – 5.15
0.495 – 0.505	16.69475 – 16.69525	1300 – 1427	5.35 – 5.46
2.1735 – 2.1905	25.5 – 25.67	1435 – 1626.5	7.25 – 7.75
4.125 – 4.128	37.5 – 38.25	1645.5 – 1646.5	8.025 – 8.5
4.17725 – 4.17775	73 – 74.6	1660 – 1710	9.0 – 9.2
4.20725 – 4.20775	74.8 – 75.2	1718.8 – 1722.2	9.3 – 9.5
6.215 – 6.218	108 – 121.94	2200 – 2300	10.6 – 12.7
6.26775 – 6.26825	123 – 138	2310 – 2390	13.25 – 13.4
6.31175 – 6.31225	149.9 – 150.05	2483.5 – 2500	14.47 – 14.5
8.291 – 8.294	156.52475 – 156.52525	2690 – 2900	15.35 – 16.2
8.362 – 8.366	156.7 – 156.9	3260 – 3267	17.7 – 21.4
8.37625 – 8.38675	162.0125 – 167.17	3.332 – 3.339	22.01 – 23.12
8.41425 – 8.41475	167.72 – 173.2	3.3458 – 3.358	23.6 – 24.0
12.29 – 12.293	240 – 285	3.600 – 4.400	31.2 – 31.8
12.51975 – 12.52025	322 – 335.4		36.43 – 36.5
12.57675 – 12.57725	399.9 – 410		Above 38.6
13.36 – 13.41	608 – 614		

b) Except as provided in 15.205 paragraphs (d) and (e), the field strength of emissions appearing within these frequency bands shall not exceed the limits shown in Section 15.209. At frequencies equal to or less than 1000 MHz, compliance with the limits in Section 15.209 shall be demonstrated using measurement instrumentation employing a CISPR quasi-peak detector. Above 1000 MHz, compliance with the emission limits in Section 15.209 shall be demonstrated based on the average value of the measured emissions. The provisions in Section 15.35 apply to these measurements.

(c) Except as provided in paragraphs (d) and (e), regardless of the field strength limits specified elsewhere in this Subpart, the provisions of this Section apply to emissions from any intentional radiator.

Compliant

N/A

6.2 Applicable Standard: FCC §15.209 Radiated emission limits, general requirements.

a) Except as provided elsewhere in this Subpart, the emissions from an intentional radiator shall not exceed the field strength levels specified in the following table:

Frequency (MHz)	Field Strength (micro volts/m)	Measurement Distance (meters)
0.009 - 0.490	2400/F(kHz)	300
0.490 - 1.705	24000/F(kHz)	30
1.705 - 30.0	30	30
30 - 88	100**	3
88 - 216	150**	3
216 - 960	200**	3
Above 960	500	3

** Except as provided in paragraph (g), fundamental emissions from intentional radiators operating under this Section shall not be located in the frequency bands 54-72 MHz, 76-88 MHz, 174-216 MHz or 470-806 MHz. However, operation within these frequency bands is permitted under other sections of this Part, e.g., Sections 15.231 and 15.241.

b) In the emission table above, the tighter limit applies at the band edges.

Compliant

N/A

(d) In any 100 kHz bandwidth outside the frequency band in which the spread spectrum or digitally modulated intentional radiator is operating, the radio frequency power that is produced by the intentional radiator shall be at least 20 dB below that in the 100 kHz bandwidth within the band that contains the highest level of the desired power, based on either an RF conducted or a radiated measurement, provided the transmitter demonstrates compliance with the peak conducted power limits. If the transmitter complies with the conducted power limits based on the use of RMS averaging over a time interval, as permitted under paragraph (b)(3) of this section, the attenuation required under this paragraph shall be 30 dB instead of 20 dB. Attenuation below the general limits specified in §15.209(a) is not required. In addition, radiated emissions which fall in the restricted bands, as defined in §15.205(a), must also comply with the radiated emission limits specified in §15.209(a) (see §15.205(c)).

6.3 Test Setup

The radiated emissions tests were performed in the shielded room, using the setup in accordance with ANSI C63.4-2003. The specification used was the FCC 15 Subpart C limits.

6.4 Test Equipment List and Details

Manufacturer	Description	Model	Serial Number	Calibration Date
Agilent	Analyzer, Spectrum	E4446A	MY44303352	2007-02-23
HP	Pre, Amplifier (1 ~ 26.5 GHz)	8449B	3147A00400	2007-04-26
A.R.A	Antenna, Horn, DRG	DRG-118/A	1132	2005-08-17*

* Two years calibration cycle.

* **Statement of Traceability: BACL Corp.** attests that all calibrations have been performed per the NVLAP requirements, traceable to the NIST.

6.5 Environmental Conditions

Temperature:	23 °C
Relative Humidity:	40 %
ATM Pressure:	102.0 kPa

*The testing was performed by James Ma on 2007-04-13.

6.6 Test Procedure

Maximizing procedure was performed on the highest emissions to ensure that the EUT complied with all installation combinations.

The EUT is set 3 meter away from the testing antenna, which is varied from 1-4 mete, and the EUT is placed on a turntable, which is 0.8 meter above ground plane, the table shall be rotated for 360 degrees to find out the highest emission. The receiving antenna should be changed the polarization both of horizontal and vertical.

The spectrum analyzer or receiver is set as:

Below 1000MHz:

$$\text{RBW} = 100 \text{ kHz} / \text{VBW} = 300 \text{ kHz} / \text{Sweep} = \text{Auto}$$

Above 1000MHz:

(1) Peak: $\text{RBW} = 1\text{MHz} / \text{VBW} = 1\text{MHz} / \text{Sweep} = \text{Auto}$
Average: $\text{RBW} = 1\text{MHz} / \text{VBW} = 10\text{Hz} / \text{Sweep} = \text{Auto}$

6.7 Corrected Amplitude & Margin Calculation

The Corrected Amplitude is calculated by adding the Antenna Factor and Cable Factor, and subtracting the Amplifier Gain from the Amplitude reading. The basic equation is as follows:

$$\text{Corrected Amplitude} = \text{Indicated Reading} + \text{Antenna Factor} + \text{Cable Factor} - \text{Amplifier Gain}$$

The “**Margin**” column of the following data tables indicates the degree of compliance with the applicable limit. For example, a margin of -7dB means the emissions are 7dB below the maximum limit. The equation for margin calculation is as follows:

$$\text{Margin} = \text{Corrected Amplitude} - \text{Limit}$$

6.8 Summary of Test Results

According to the test data, the EUT complied with the FCC Title 47, Part 15 Subpart C sections 205, 209 and 247 standards’ limits, with the closest margins from the limit listed below:

-16.6 dB at 7206.0000 MHz in the Vertical polarization, Low Channel

-16.2 dB at 7323.0000 MHz in the Vertical polarization, Middle Channel

-14.8 dB at 7440.0000 MHz in the Vertical polarization, High Channel

6.9 Radiated Spurious Emissions Test Data**Run#1 Radiated Harmonics and Spurious Emissions**

Low Channel (2402 MHz)

Frequency (MHz)	Reading (dB μ V)	Azimuth (Degrees)	Height (m)	Polarization (H / V)	Antenna Factor (dB/m)	Cable loss (dB)	Pre-Amp. Gain (dB)	Corrected Reading (dB μ V/m)	FCC 15 C		Comments
									Limit (dB μ V/m)	Margin (dB)	
2402.0000	98.2	10	1.3	V	28.7	1.5	35.8	92.5			Fund/Peak
2402.0000	90.4	30	1.2	H	28.7	1.5	35.8	84.7			Fund/Peak
2402.0000	58.9	10	1.3	V	28.7	1.5	35.8	53.2			Ave
2402.0000	55.4	30	1.2	H	28.7	1.5	35.8	49.7			Ave
7206.0000	31.2	180	2.0	V	36.7	4.2	34.7	37.4	54	-16.6	Ave
7206.0000	30.0	90	2.0	H	36.7	4.2	34.7	36.2	54	-17.8	Ave
4804.0000	34.7	270	2.4	V	32.5	1.9	34.8	34.3	54	-19.7	Ave
4804.0000	31.2	180	2.3	H	32.5	1.9	34.8	30.8	54	-23.2	Ave
4804.0000	47.6	270	2.4	V	32.5	1.9	34.8	47.2	74	-26.8	Peak
7206.0000	40.9	90	2.0	V	36.7	4.2	34.7	47.1	74	-26.9	Peak
7206.0000	38.2	180	2.0	H	36.7	4.2	34.7	44.4	74	-29.6	Peak
4804.0000	43.4	180	2.3	H	32.5	1.9	34.8	43.0	74	-31.0	Peak

Middle Channel (2441 MHz)

Frequency (MHz)	Reading (dB μ V)	Azimuth (Degrees)	Height (m)	Polarization (H / V)	Antenna Factor (dB/m)	Cable loss (dB)	Pre-Amp. Gain (dB)	Corrected Reading (dB μ V/m)	FCC 15 C		Comments
									Limit (dB μ V/m)	Margin (dB)	
2441.0000	100.8	20	1.1	V	28.7	1.5	35.8	95.1			Fund/Peak
2441.0000	92.8	50	1.2	H	28.7	1.5	35.8	87.1			Fund/Peak
2441.0000	62.3	20	1.1	V	28.7	1.5	35.8	56.6			Ave
2441.0000	53.3	50	1.2	H	28.7	1.5	35.8	47.6			Ave
7323.0000	31.6	270	2.4	V	36.7	4.2	34.7	37.8	54	-16.2	Ave
7323.0000	29.8	180	2.1	H	36.7	4.2	34.7	36.0	54	-18.0	Ave
4882.0000	35.4	330	2.0	V	32.5	1.9	34.8	35.0	54	-19.0	Ave
4882.0000	30.6	180	2.2	H	32.5	1.9	34.8	30.2	54	-23.8	Ave
4882.0000	49.8	330	2.0	V	32.5	1.9	34.8	49.4	74	-24.6	Peak
7323.0000	42.3	270	2.4	V	36.7	4.2	34.7	48.5	74	-25.5	Peak
7323.0000	41.0	180	2.3	H	36.7	4.2	34.7	47.2	74	-26.8	Peak
4882.0000	43.7	180	2.2	H	32.5	1.9	34.8	43.3	74	-30.7	Peak

High Channel (2480 MHz)

Frequency (MHz)	Reading (dB μ V)	Azimuth (Degrees)	Height (m)	Polarization (H / V)	Antenna Factor (dB/m)	Cable loss (dB)	Pre-Amp. Gain (dB)	Corrected Reading (dB μ V/m)	FCC 15 C		Comments
									Limit (dB μ V/m)	Margin (dB)	
2480.0000	101.3	30	1.3	V	28.7	1.5	35.8	95.6			Fund/Peak
2480.0000	93.5	50	1.2	H	28.7	1.5	35.8	87.8			Fund/Peak
2480.0000	64.4	30	1.3	V	28.7	1.5	35.8	58.7			Ave
2480.0000	54.8	50	1.2	H	28.7	1.5	35.8	49.1			Ave
7440.0000	33.0	270	2.4	V	36.7	4.2	34.7	39.2	54	-14.8	Ave
7440.0000	31.5	90	2.1	H	36.7	4.2	34.7	37.7	54	-16.3	Ave
4960.0000	37.2	270	2.4	V	32.5	1.9	34.8	36.8	54	-17.2	Ave
4960.0000	32.0	90	2.1	H	32.5	1.9	34.8	31.6	54	-22.4	Ave
7440.0000	43.9	270	2.4	V	36.7	4.2	34.7	50.1	74	-23.9	Peak
4960.0000	50.3	270	2.4	V	32.5	1.9	34.8	49.9	74	-24.1	Peak
7440.0000	42.2	90	2.1	H	36.7	4.2	34.7	48.4	74	-25.6	Peak
4960.0000	44.6	90	2.1	H	32.5	1.9	34.8	44.2	74	-29.8	Peak

7 §15.247 (D) SPURIOUS EMISSIONS AT ANTENNA TERMINALS

7.1 Applicable Standard

According to §15.247 (d) In any 100 kHz bandwidth outside the frequency band in which the spread spectrum or digitally modulated intentional radiator is operating, the radio frequency power that is produced by the intentional radiator shall be at least 20 dB below that in the 100 kHz bandwidth within the band that contains the highest level of the desired power, based on either an RF conducted or a radiated measurement, provided the transmitter demonstrates compliance with the peak conducted power limits. If the transmitter complies with the conducted power limits based on the use of RMS averaging over a time interval, as permitted under paragraph (b)(3) of this section, the attenuation required under this paragraph shall be 30 dB instead of 20 dB. Attenuation below the general limits specified in §15.209(a) is not required. In addition, radiated emissions which fall in the restricted bands, as defined in §15.205(a), must also comply with the radiated emission limits specified in §15.209(a) (see §15.205(c)).

7.2 Measurement Procedure

1. Check the calibration of the measuring instrument (SA) using either an internal calibrator or a known signal from an external generator.
2. Position the EUT on a bench without connection to measurement instrument. Turn on the EUT and connect its antenna terminal to measurement instrument via a low loss cable. Then set it to any one measured frequency within its operating range, and make sure the instrument is operated in its linear range.
3. Set the SA on Max-Hold Mode, and then keep the EUT in transmitting mode. Record all the signals from each channel until each one has been recorded.
4. Set the SA on View mode and then plot the result on SA screen.
5. Repeat above procedures until all frequencies measured were complete.

7.3 Test Equipment

Manufacturer	Description	Model Number	Serial Number	Calibration Date
Agilent	Analyzer, Spectrum	E4446A	US44300386	2006-04-26

* **Statement of Traceability: BAEL Corp.** attests that all calibrations have been performed per the NVLAP requirements, traceable to the NIST.

7.4 Test Setup Diagram

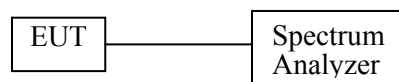

7.5 Environmental Conditions

Temperature:	23 °C
Relative Humidity:	40 %
ATM Pressure:	102.0 kPa

*The testing was performed by James Ma on 2007-04-13.

Please refer to the following plots.

7.6 Measurement Results

Low Channel

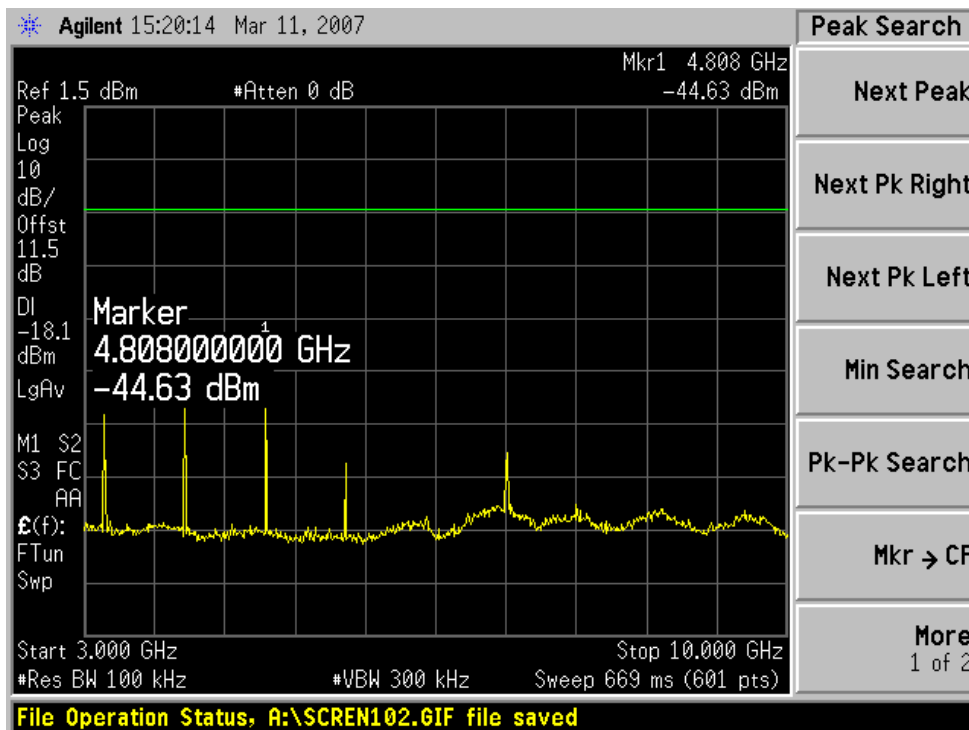
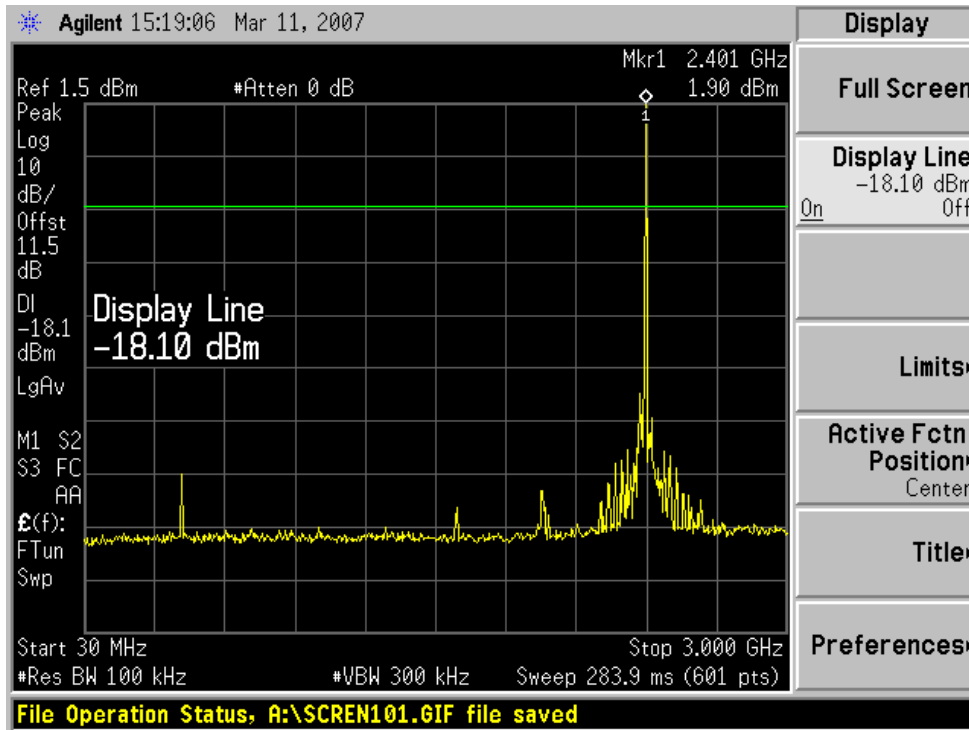

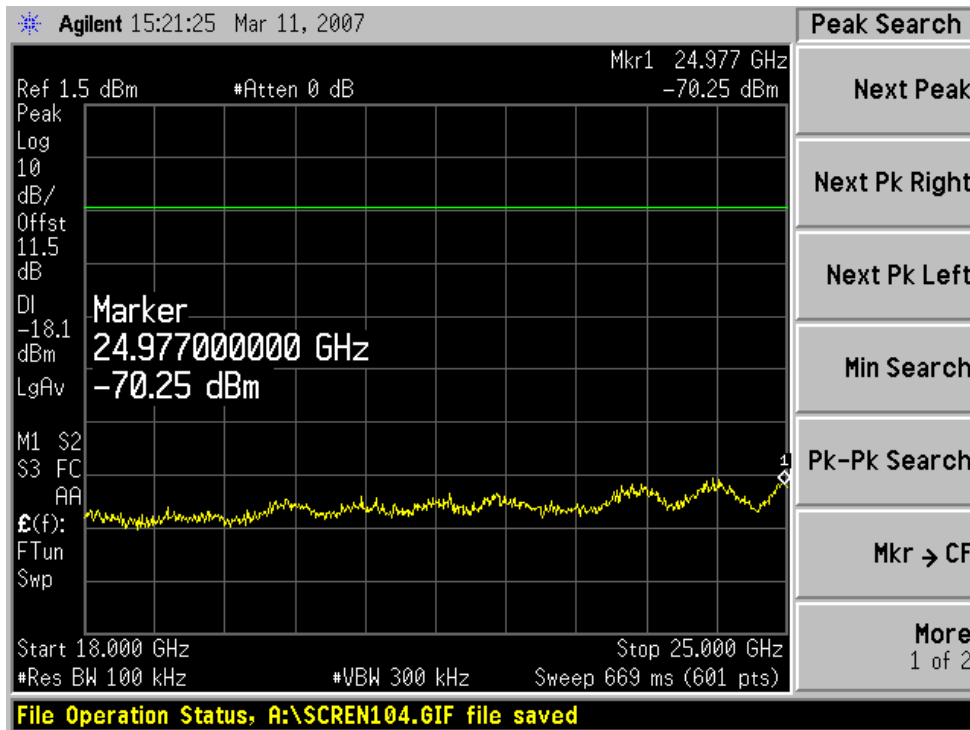
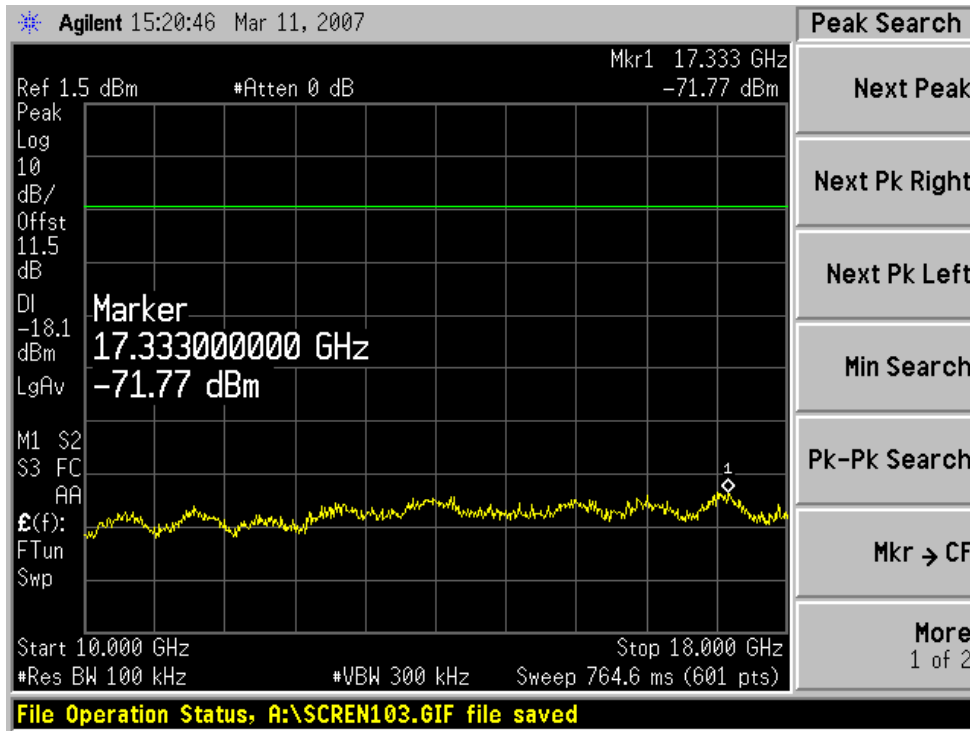

Middle Channel

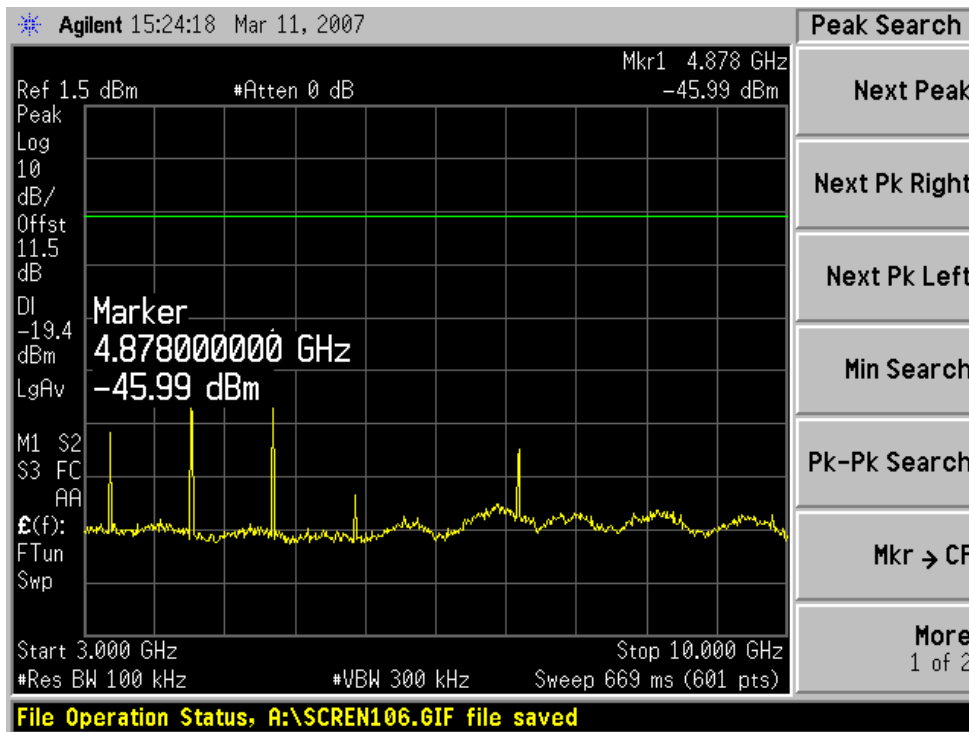
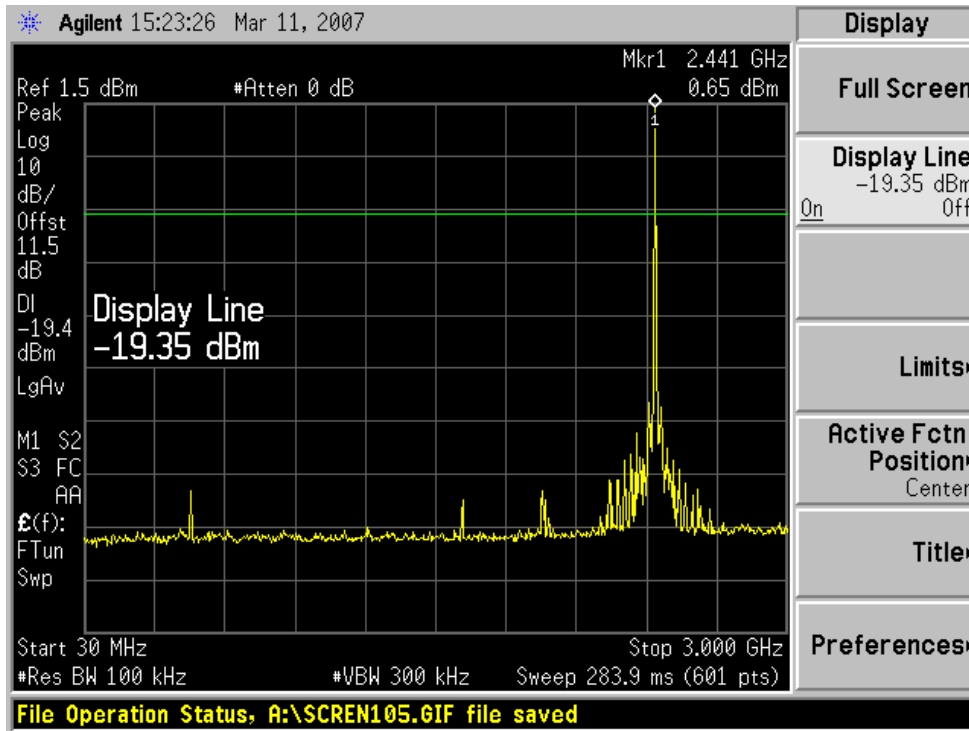

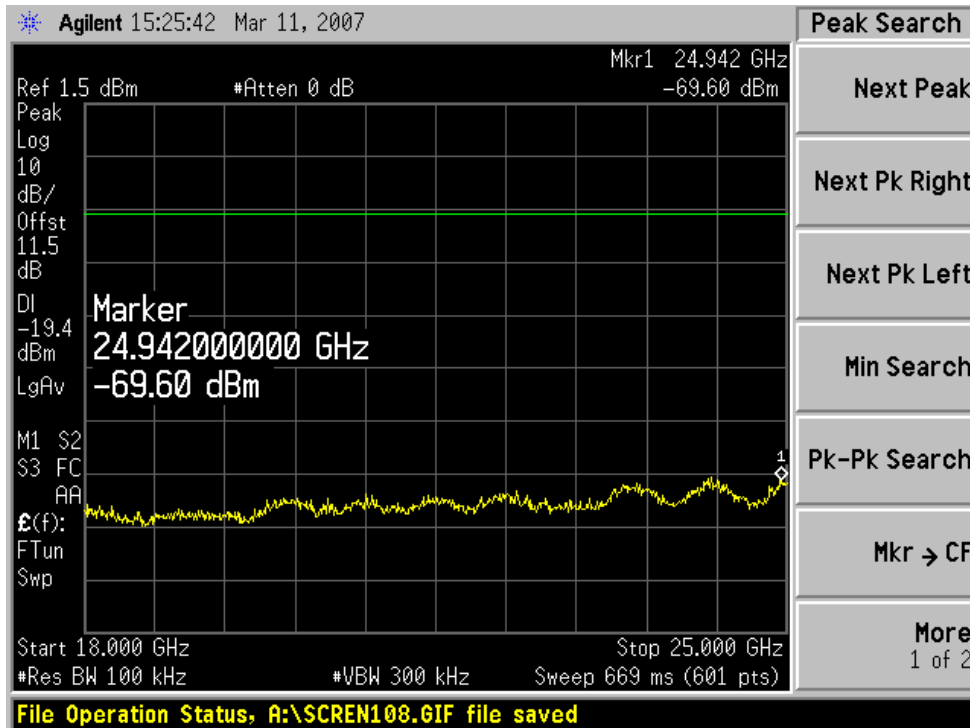
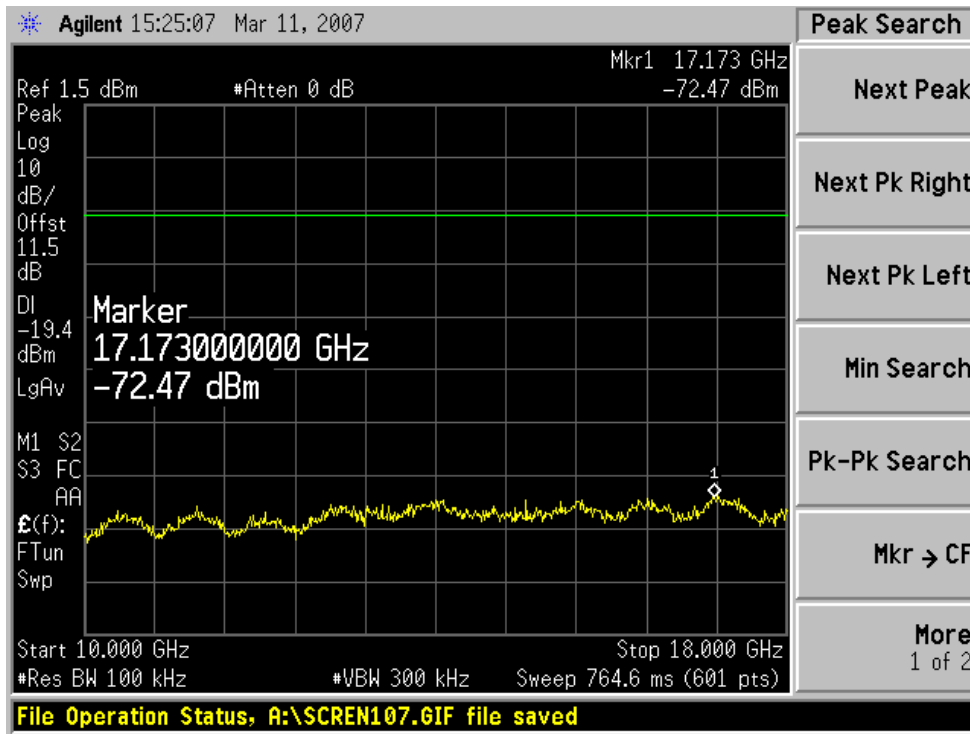

High Channel

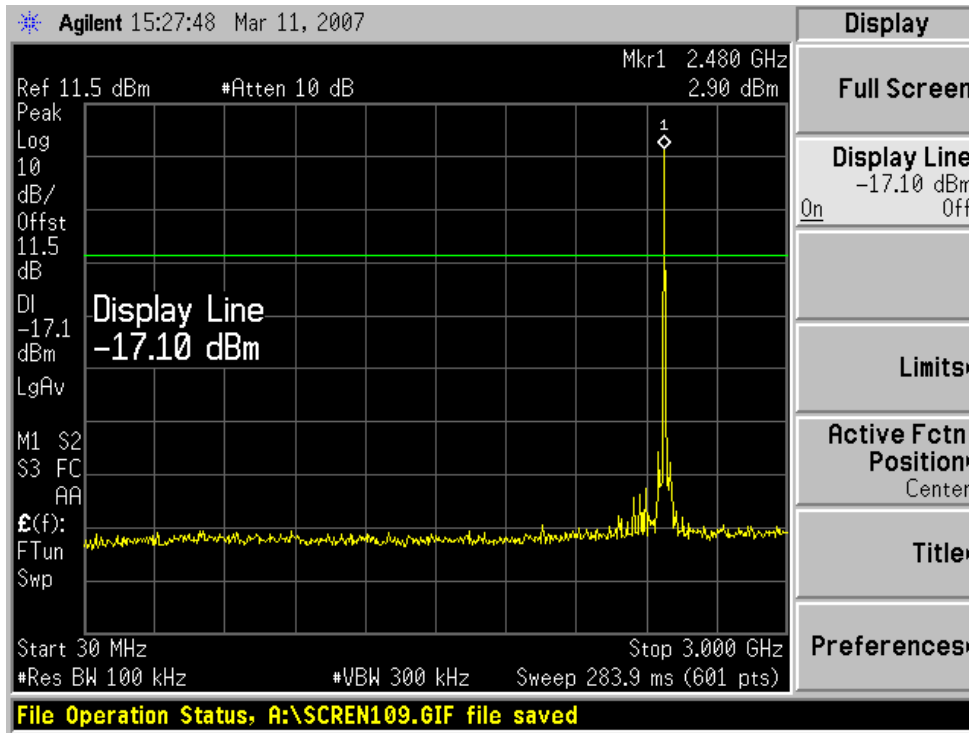

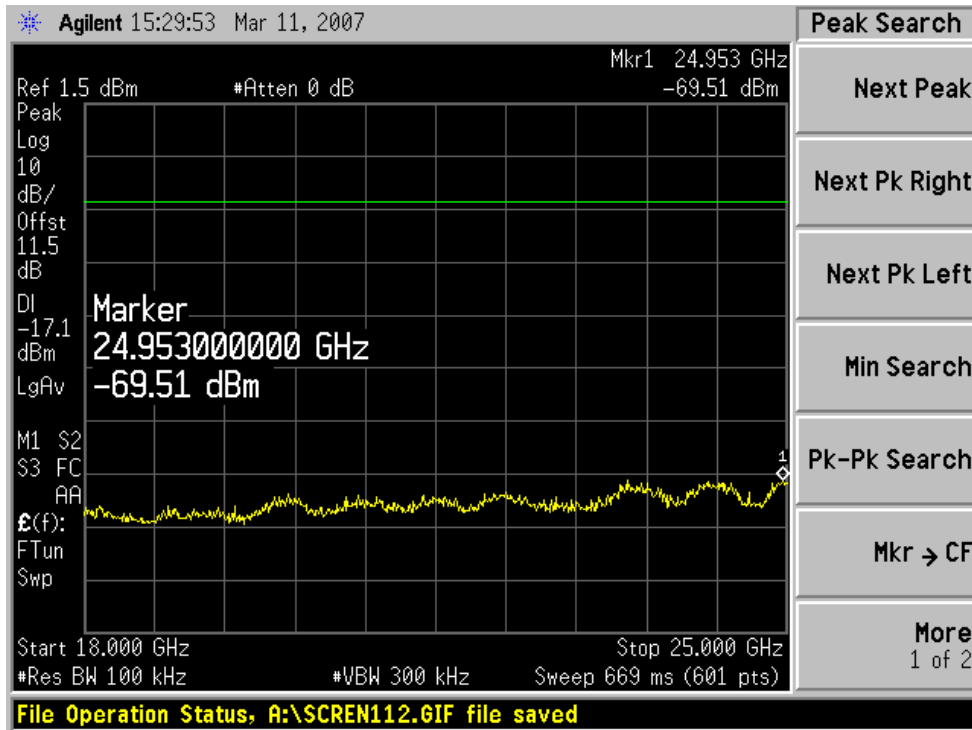
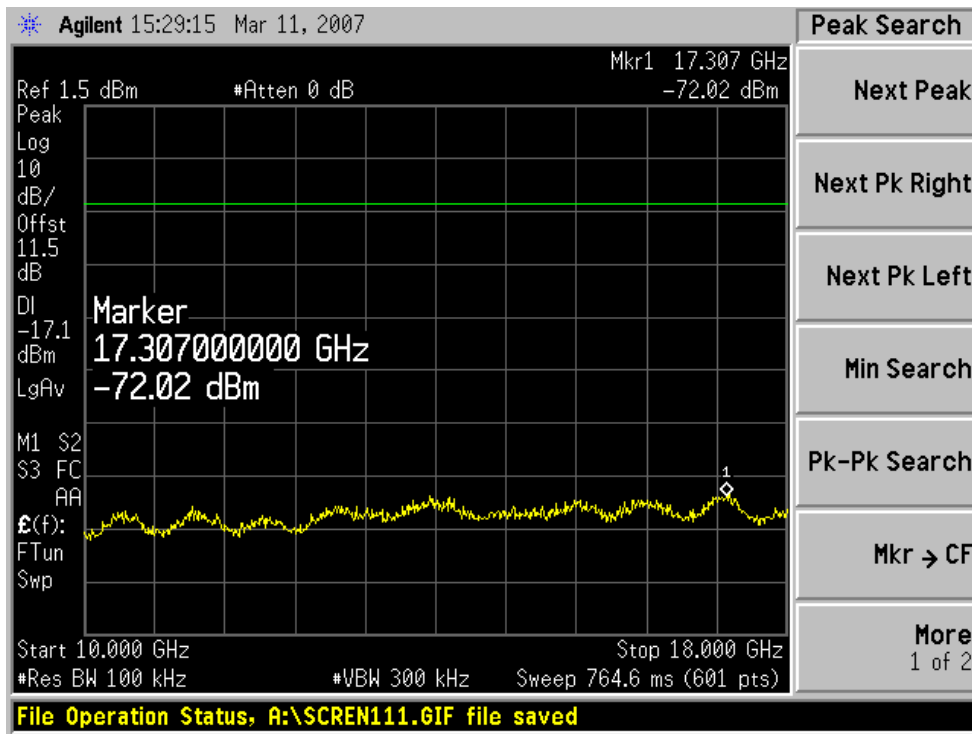

8 §15.247 (a) (1) - HOPPING CHANNEL SEPARATION

8.1 Applicable Standard

According to §15.247(a)(1): Frequency hopping systems shall have hopping channel carrier frequencies separated by a minimum of 25 kHz or the 20 dB bandwidth of the hopping channel, whichever is greater. Alternatively, frequency hopping systems operating in the 2400–2483.5 MHz band may have hopping channel carrier frequencies that are separated by 25 kHz or two-thirds of the 20 dB bandwidth of the hopping channel, whichever is greater, provided the systems operate with an output power no greater than 125 mW. The system shall hop to channel frequencies that are selected at the system hopping rate from a pseudo randomly ordered list of hopping frequencies. Each frequency must be used equally on the average by each transmitter. The system receivers shall have input bandwidths that match the hopping channel bandwidths of their corresponding transmitters and shall shift frequencies in synchronization with the transmitted signals.

8.2 Measurement Procedure

1. Check the calibration of the measuring instrument (SA) using either an internal calibrator or a known signal from an external generator.
2. Position the EUT on a bench without connection to measurement instrument Turn on the EUT and connect it to measurement instrument. Then set it to any one convenient frequency within its operating range.
3. By using the Max-Hold function record the separation of two adjacent channels.
4. Measure the frequency difference of these two adjacent channels by SA MARK function, and then plot the result on SA screen.
5. Repeat above procedures until all frequencies measured were complete.

8.3 Test Equipment

Manufacturer	Description	Model Number	Serial Number	Calibration Date
Agilent	Analyzer, Spectrum	E4446A	US44300386	2006-04-26

* **Statement of Traceability: BACL Corp.** attests that all calibrations have been performed per the NVLAP requirements, traceable to the NIST.

8.4 Test Setup Diagram

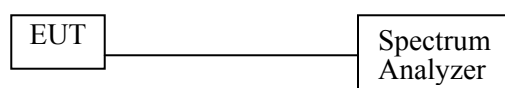

8.5 Environmental Conditions

Temperature:	23 °C
Relative Humidity:	40 %
ATM Pressure:	102.0 kPa

*The testing was performed by James Ma on 2007-04-13.

8.6 Measurement Results

Channel	Frequency (MHz)	Channel Separation (kHz)	Limit (kHz)
Low	2402	1042	684.7
Mid	2441	1042	684.7
High	2480	1042	684.7

Please refer to the following plots.

Low Channel

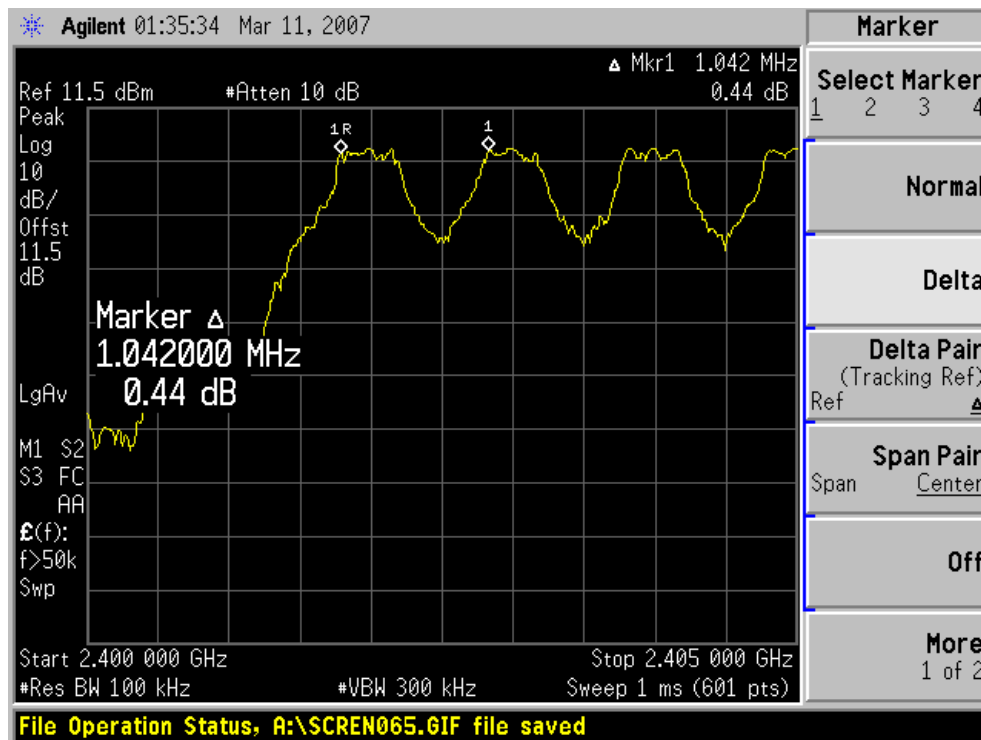

Middle Channel

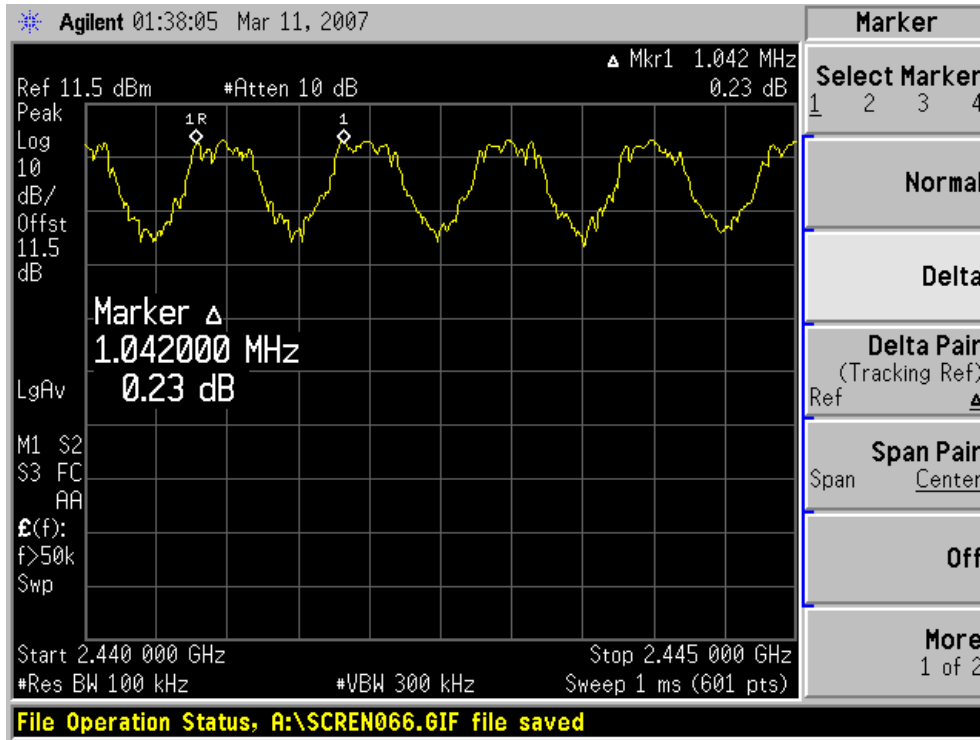

High Channel

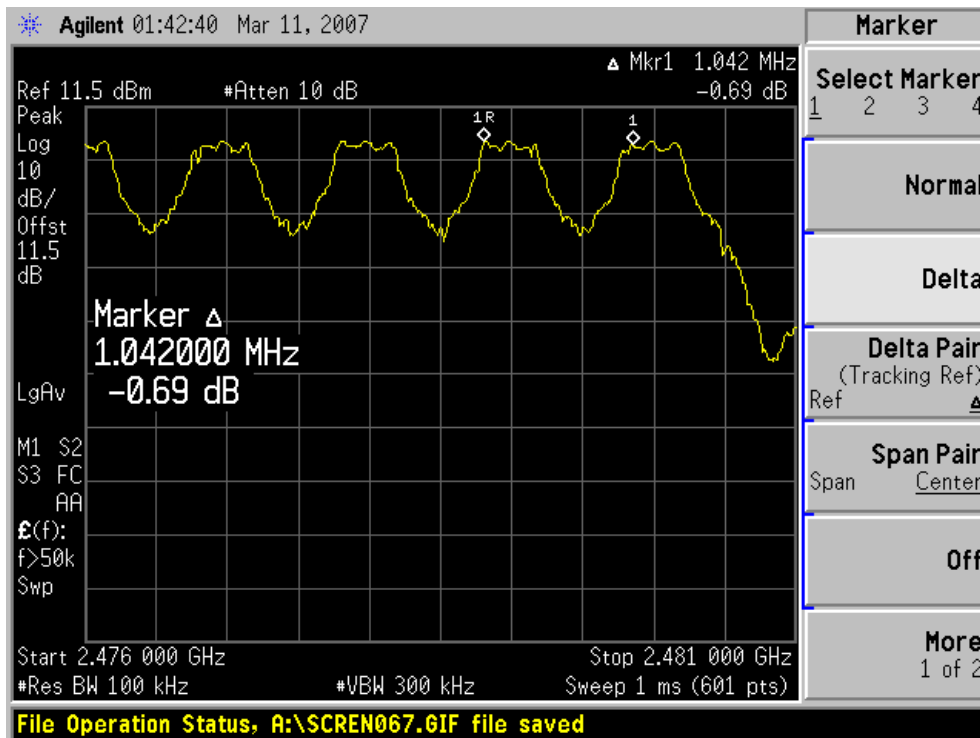

9 §15.247 (a) (1) – HOPPING CHANNEL BANDWIDTH

9.1 Standard Applicable

According to §15.247 (a)(1) Frequency hopping systems shall have hopping channel carrier frequencies separated by a minimum of 25 kHz or the 20 dB bandwidth of the hopping channel, whichever is greater. Alternatively, frequency hopping systems operating in the 2400–2483.5 MHz band may have hopping channel carrier frequencies that are separated by 25 kHz or two-thirds of the 20 dB bandwidth of the hopping channel, whichever is greater, provided the systems operate with an output power no greater than 125 mW. The system shall hop to channel frequencies that are selected at the system hopping rate from a pseudo randomly ordered list of hopping frequencies. Each frequency must be used equally on the average by each transmitter. The system receivers shall have input bandwidths that match the hopping channel bandwidths of their corresponding transmitters and shall shift frequencies in synchronization with the transmitted signals.

9.2 Measurement Procedure

1. Check the calibration of the measuring instrument using either an internal calibrator or a known signal from an external generator.
2. Position the EUT without connection to measurement instrument. Turn on the EUT and connect it to measurement instrument. Then set it to any one convenient frequency within its operating range. Set a reference level on the measuring instrument equal to the highest peak value.
3. Measure the frequency difference of two frequencies that were attenuated 20 dB from the reference level. Record the frequency difference as the emissions bandwidth.
4. Repeat above procedures until all frequencies measured were complete.

9.3 Test Equipment List and Details

Manufacturer	Description	Model Number	Serial Number	Calibration Date
Agilent	Analyzer, Spectrum	E4446A	US44300386	2006-04-26

* **Statement of Traceability: BACL Corp.** attests that all calibrations have been performed per the NVLAP requirements, traceable to the NIST.

9.4 Test Setup Diagram

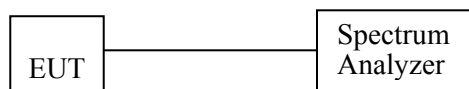

9.5 Environmental Conditions

Temperature:	23 °C
Relative Humidity:	40 %
ATM Pressure:	102.0 kPa

**The testing was performed by James Ma on 2007-04-13.*

9.6 Measurement Results

Channel	Frequency (MHz)	20 dB Channel Bandwidth (kHz)
Low	2402	1027
Mid	2441	1027
High	2480	1027

Please refer to the following plots.

9.7 Measurement Test Result

Low Channel

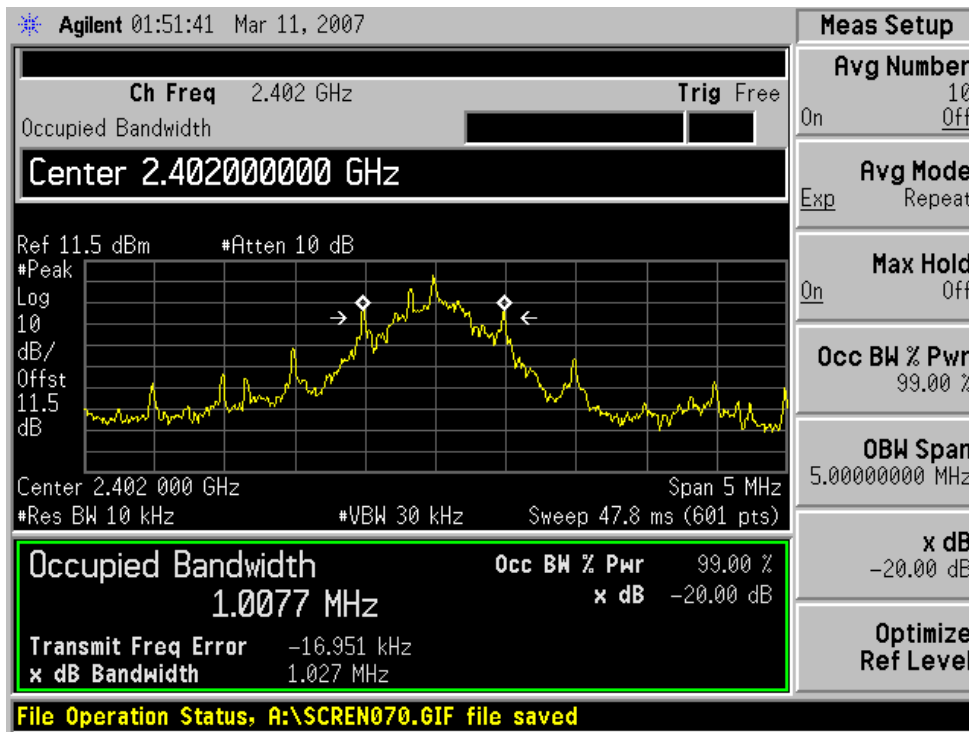

Middle Channel

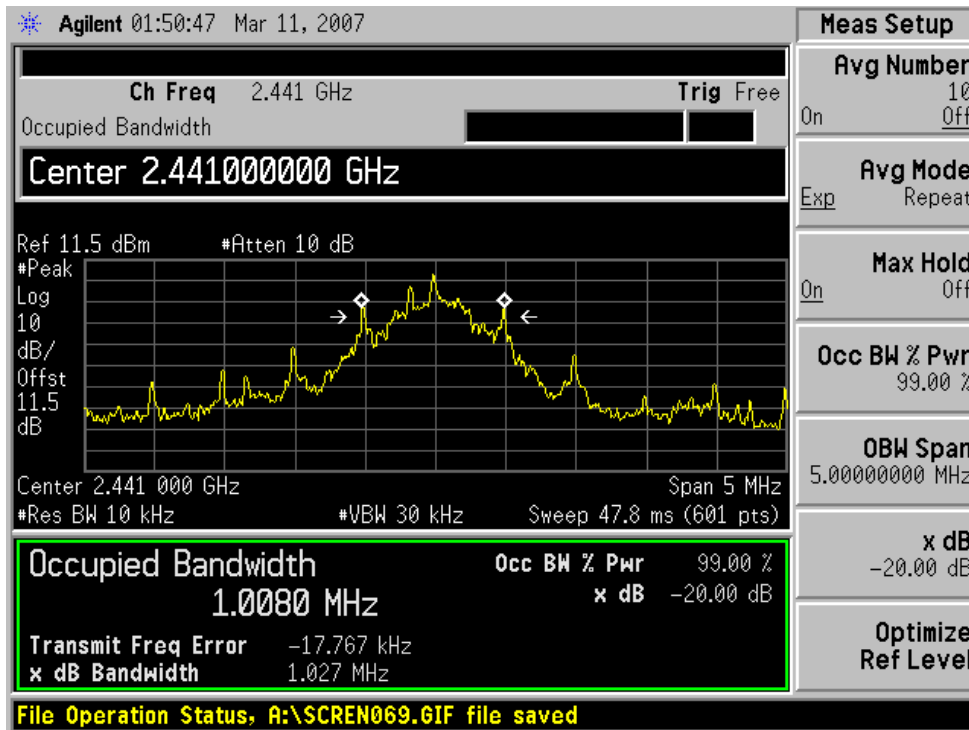

High Channel

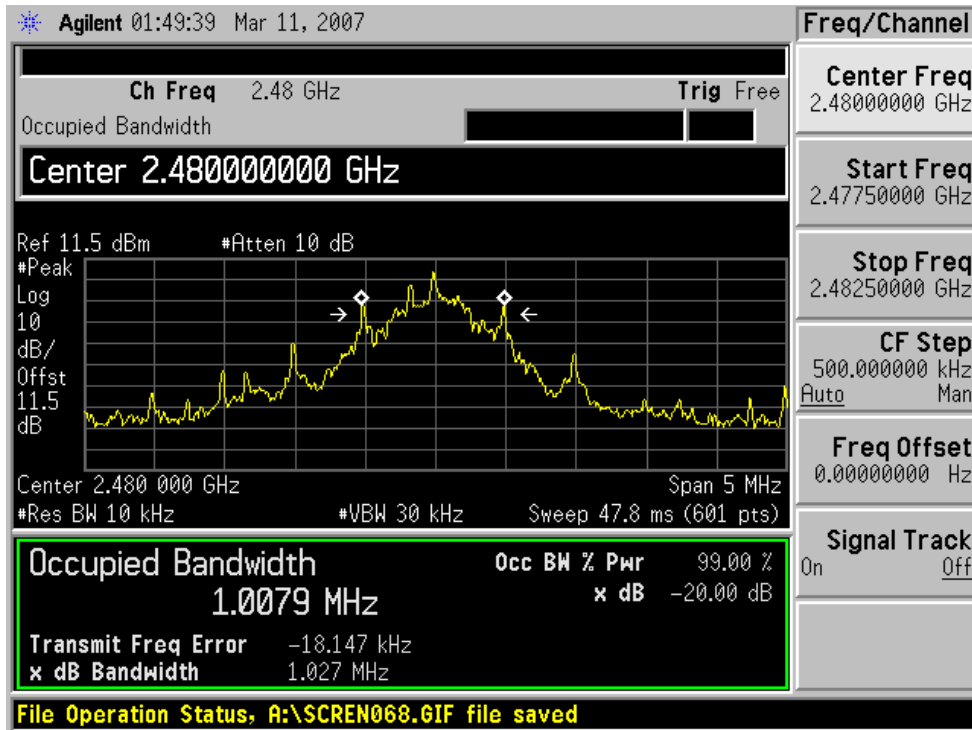

10 §15.247 (a) (1) (iii) - NUMBER OF HOPPING FREQUENCIES USED

10.1 Standard Applicable

According to §15.247(a)(1)(iii), Frequency hopping systems in the 2400–2483.5 MHz band shall use at least 15 channels. The average time of occupancy on any channel shall not be greater than 0.4 seconds within a period of 0.4 seconds multiplied by the number of hopping channels employed. Frequency hopping systems may avoid or suppress transmissions on a particular hopping frequency provided that a minimum of 15 channels are used.

10.2 Measurement Procedure

1. Check the calibration of the measuring instrument (SA) using either an internal calibrator or a known signal from an external generator.
2. Position the EUT on the bench without connection to measurement instrument. Turn on the EUT and connect its antenna terminal to measurement instrument via a low loss cable. Then set it to any one measured frequency within its operating range, and make sure the instrument is operated in its linear range.
3. Set the SA on Max-Hold Mode, and then keep the EUT in hopping mode. Record all the signals from each channel until each one has been recorded.
4. Set the SA on View mode and then plot the result on SA screen.
5. Repeat above procedures until all frequencies measured were complete.

10.3 Test Equipment List and Details

Manufacturer	Description	Model Number	Serial Number	Calibration Date
Agilent	Analyzer, Spectrum	E4446A	US44300386	2006-04-26

* **Statement of Traceability: BACL Corp.** attests that all calibrations have been performed per the NVLAP requirements, traceable to the NIST.

10.4 Test Setup Diagram

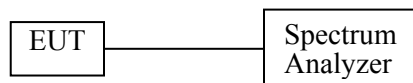

10.5 Environmental Conditions

Temperature:	23 °C
Relative Humidity:	40 %
ATM Pressure:	102.0 kPa

*The testing was performed by James Ma on 2007-04-13.

10.6 Measurement Result

Frequency Range (MHz)	Number of Hopping Channels	Limit
2402-2480	79	>15

Please refer to the following plot:

Number of Channels: 39

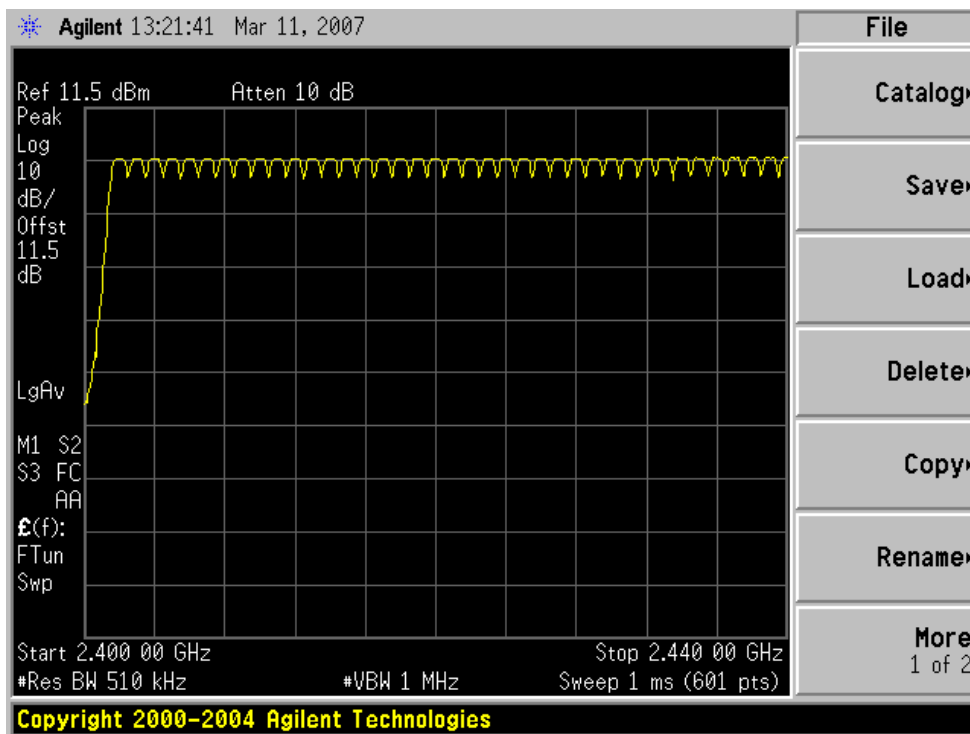

Number of Channels: 40

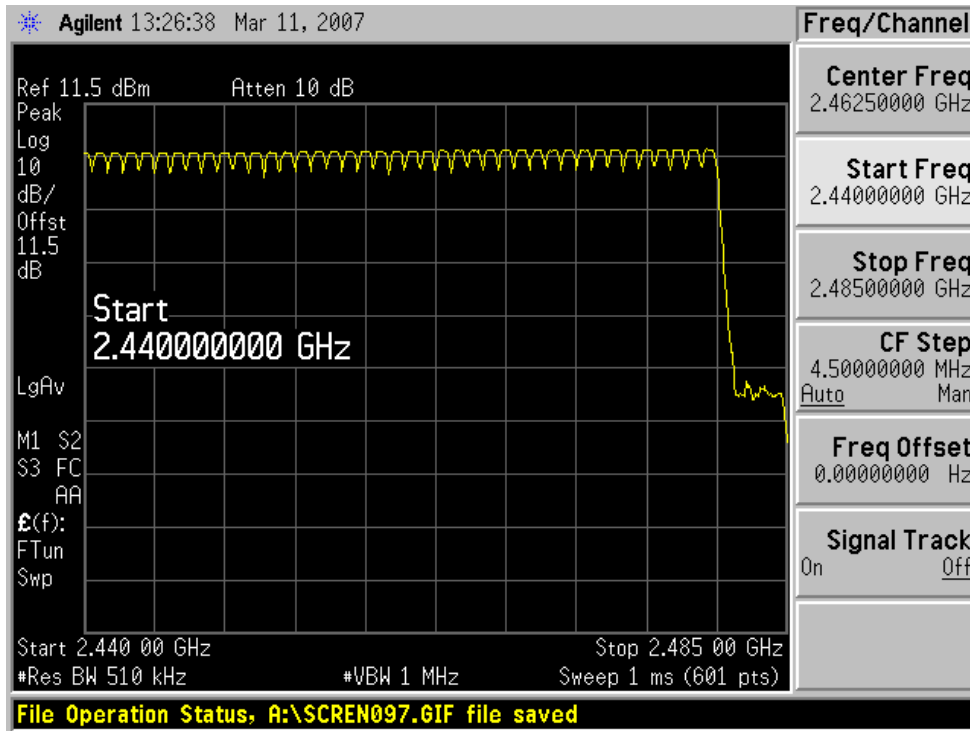

11 §15.247(a) (1) (iii) - DWELL TIME

11.1 Applicable Standard

According to §15.247 (a)(1)(iii), According to §15.247(a)(1)(iii), For Frequency hopping systems in the 2400–2483.5 MHz band the average time of occupancy on any channel shall not be greater than 0.4 seconds within a period of 0.4 seconds multiplied by the number of hopping channels employed. Frequency hopping systems may avoid or suppress transmissions on a particular hopping frequency provided that a minimum of 15 channels are used.

11.2 Measurement Procedure

1. Check the calibration of the measuring instrument using either an internal calibrator or a known signal from an external generator.
2. Position the EUT was set without connection to measurement instrument. Turn on the EUT and connect its antenna terminal to measurement instrument via a low loss cable. Then set it to any one measured frequency within its operating range, and make sure the instrument is operated in its linear range.
3. Adjust the center frequency of SA on any frequency be measured and set SA to zero span mode. And then, set RBW and VBW of spectrum analyzer to proper value.
4. Measure the time duration of one transmission on the measured frequency. And then plot the result with time difference of this time duration.
5. Repeat above procedures until all frequencies measured were complete.

11.3 Test Equipment List and Details

Manufacturer	Description	Model Number	Serial Number	Calibration Date
Agilent	Analyzer, Spectrum	E4446A	US44300386	2006-04-26

* **Statement of Traceability:** **BACL Corp.** attests that all calibrations have been performed per the NVLAP requirements, traceable to the NIST.

11.4 Test Setup Diagram

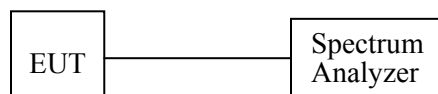

11.4.1 Environmental Conditions

Temperature:	23 °C
Relative Humidity:	40 %
ATM Pressure:	102.0 kPa

*The testing was performed by James Ma on 2007-04-13.

11.5 Measurement Results

Channel	Frequency (MHz)	Pulse Width (ms)	Pulse Quantity Per 2 Sec	Dwell Time (sec.)	Limit (Sec.)	Result
Low	2402	483.3	21	0.1604	0.4	Compliant
Mid	2441	508.3	20	0.1606	0.4	Compliant
High	2480	583.3	20	0.1843	0.4	Compliant

Please refer the following plots.

Low Channel

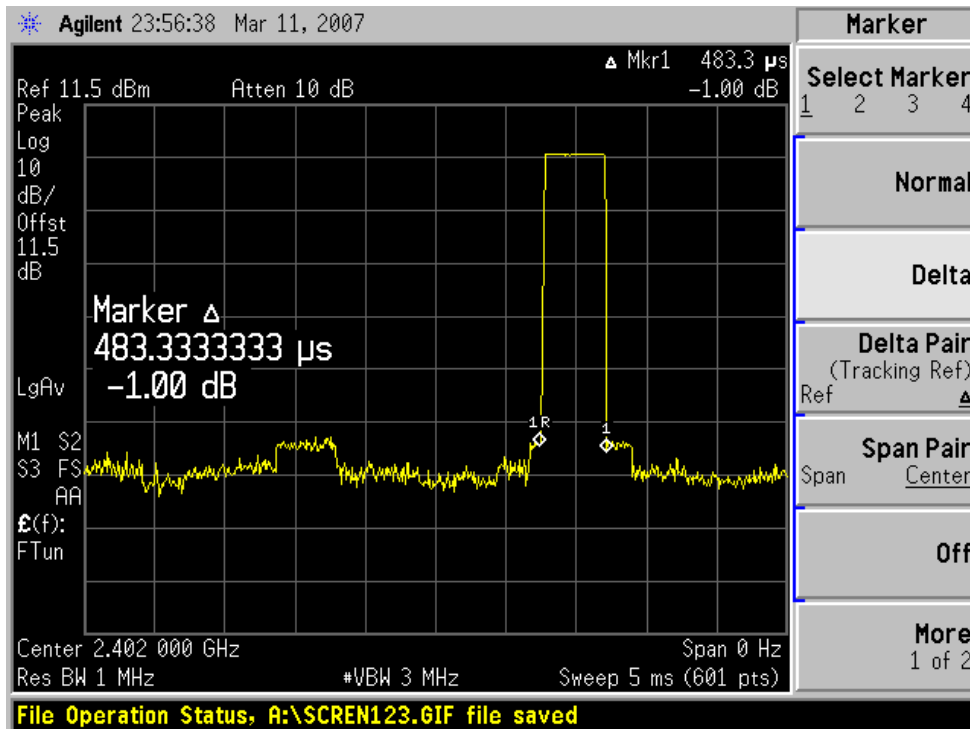
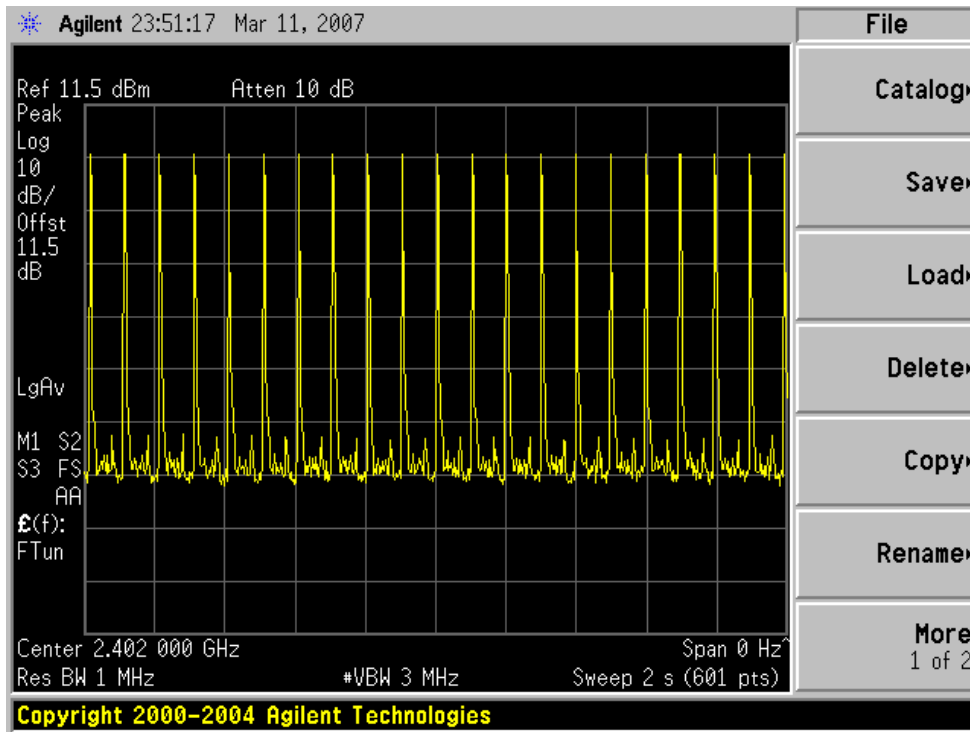

Middle Channel

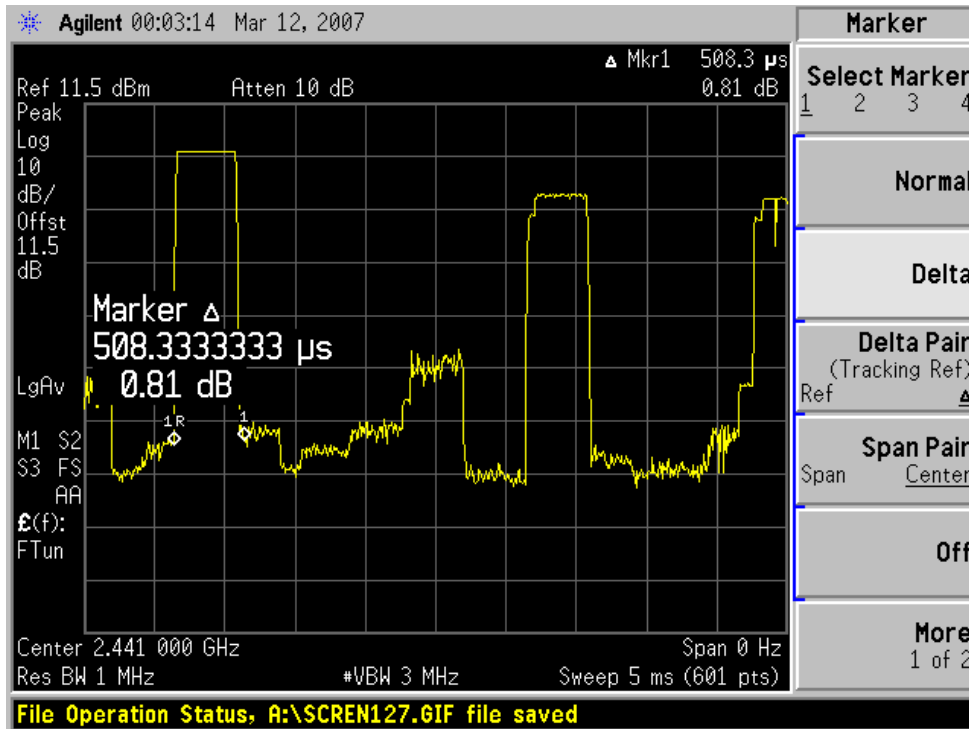
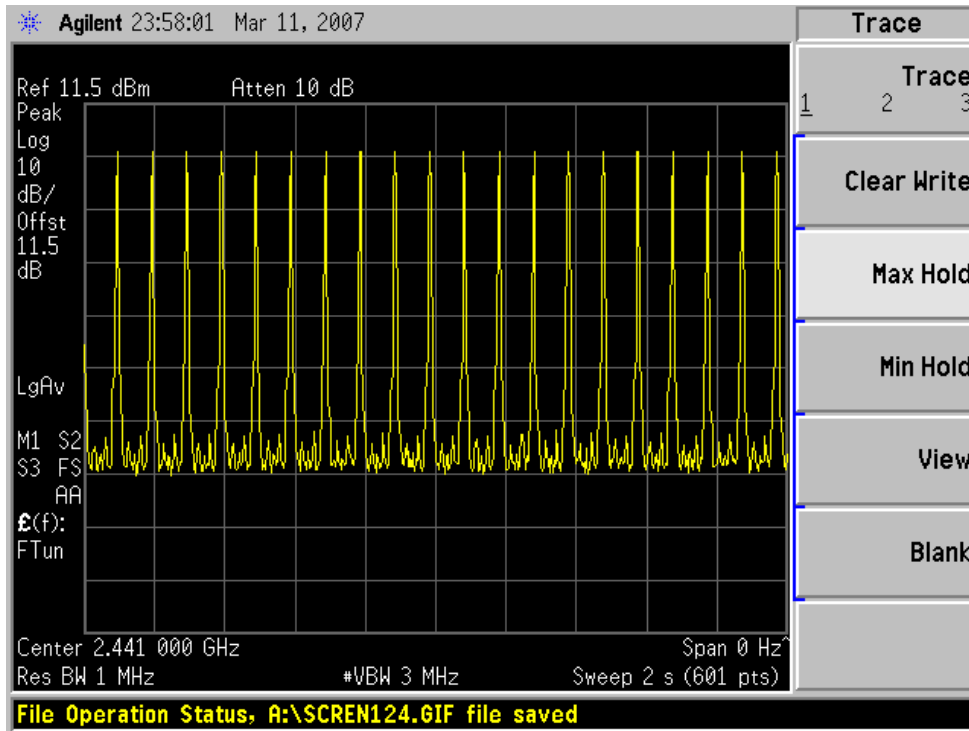

High Channel

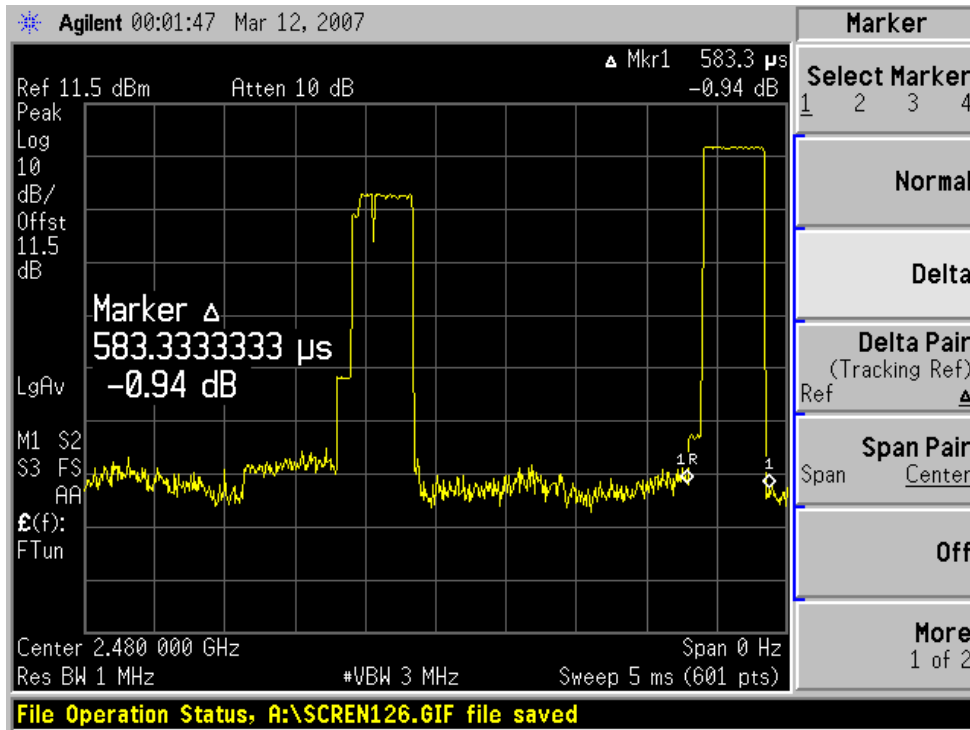
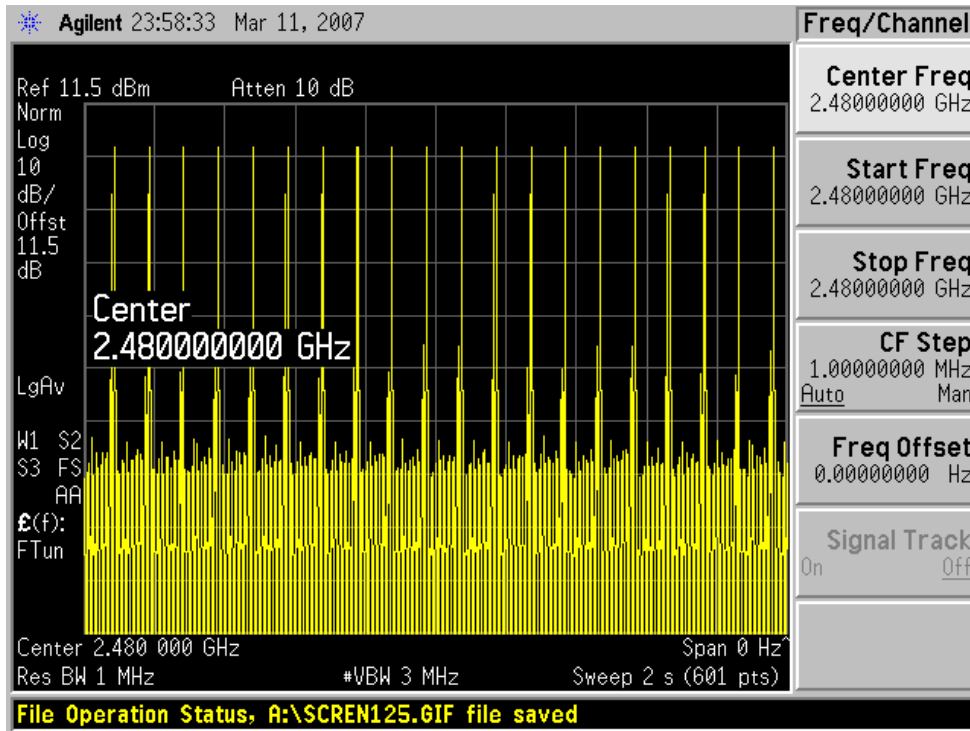

12 §15.247(B) (2) - MAXIMUM PEAK OUTPUT POWER

12.1 Standard Applicable

According to §15.247(b) (1), For frequency hopping systems operating in the 2400–2483.5 MHz band employing at least 75 non-overlapping hopping channels, and all frequency hopping systems in the 5725–5850 MHz band: 1 watt. For all other frequency hopping systems in the 2400–2483.5 MHz band: 0.125 watts.

12.2 Measurement Procedure

1. Place the EUT on the turntable and set it in transmitting mode.
2. Remove the antenna from the EUT and then connect a low loss RF cable from the antenna port to the spectrum analyzer.

12.3 Test Equipment List and Details

Manufacturer	Description	Model Number	Serial Number	Calibration Date
Agilent	Analyzer, Spectrum	E4446A	US44300386	2006-04-26

* **Statement of Traceability:** BACL Corp. attests that all calibrations have been performed per the NVLAP requirements, traceable to the NIST.

12.4 Test Setup Diagram



12.4.2 Environmental Conditions

Temperature:	23 °C
Relative Humidity:	40 %
ATM Pressure:	102.0 kPa

*The testing was performed by James Ma on 2007-04-13.

12.5 Measurement Result

Channel	Frequency (MHz)	Max Peak Output Power		Limit (mw)	Result
		(dBm)	(mw)		
Low	2402	4.24	2.65	1000	Compliant
Mid	2441	4.88	3.08	1000	Compliant
High	2480	5.26	3.36	1000	Compliant

Please see the following plots:

Low Channel

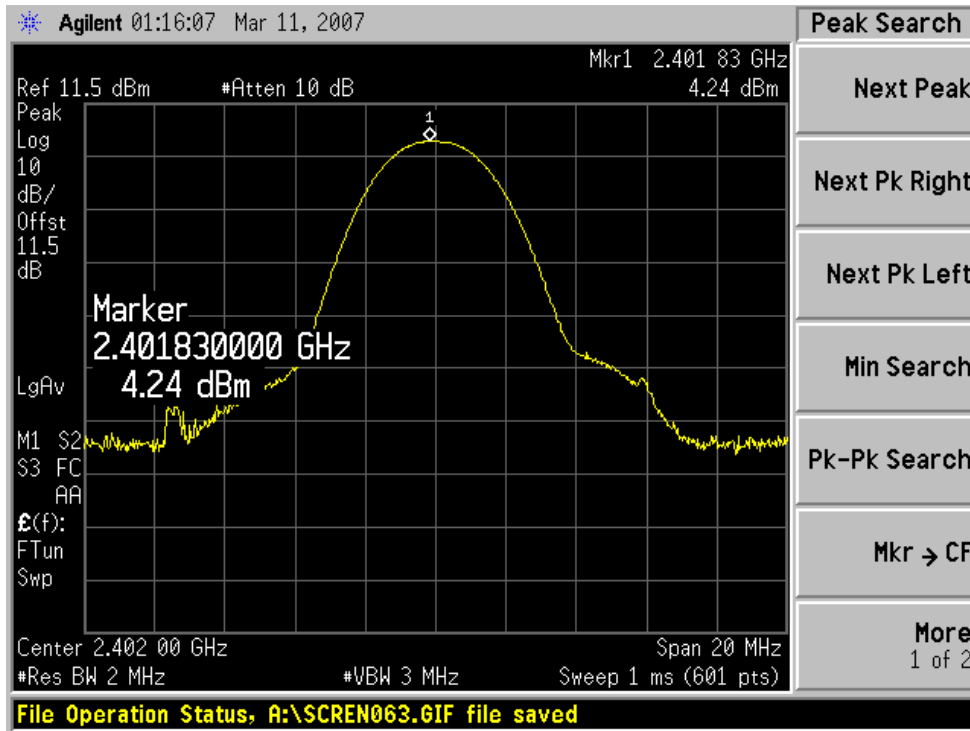

Middle Channel

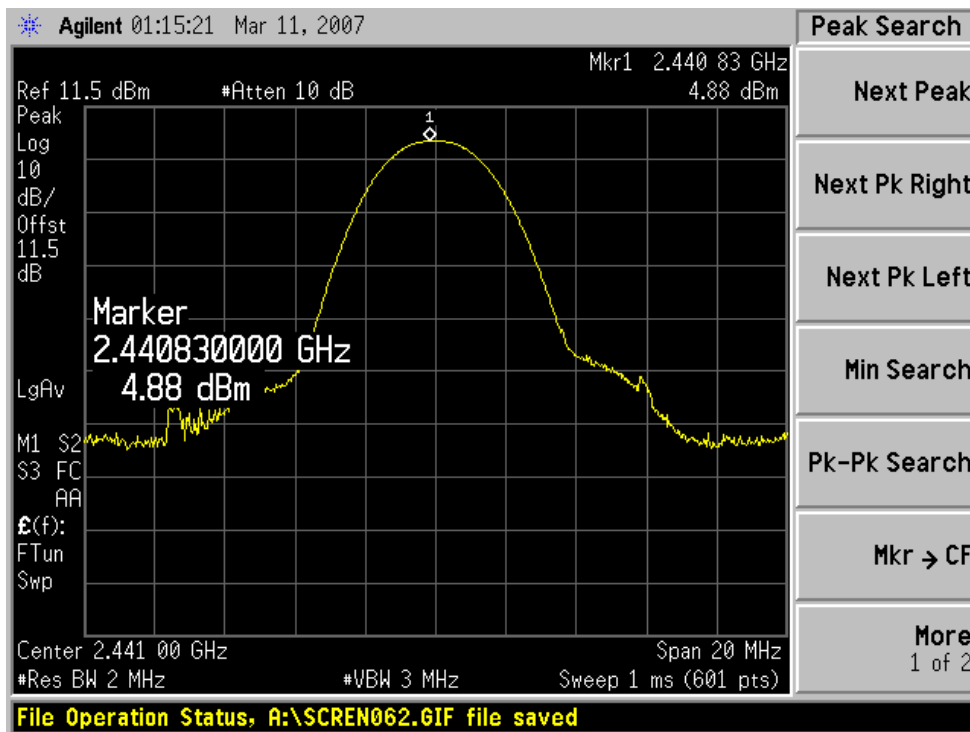

High Channel

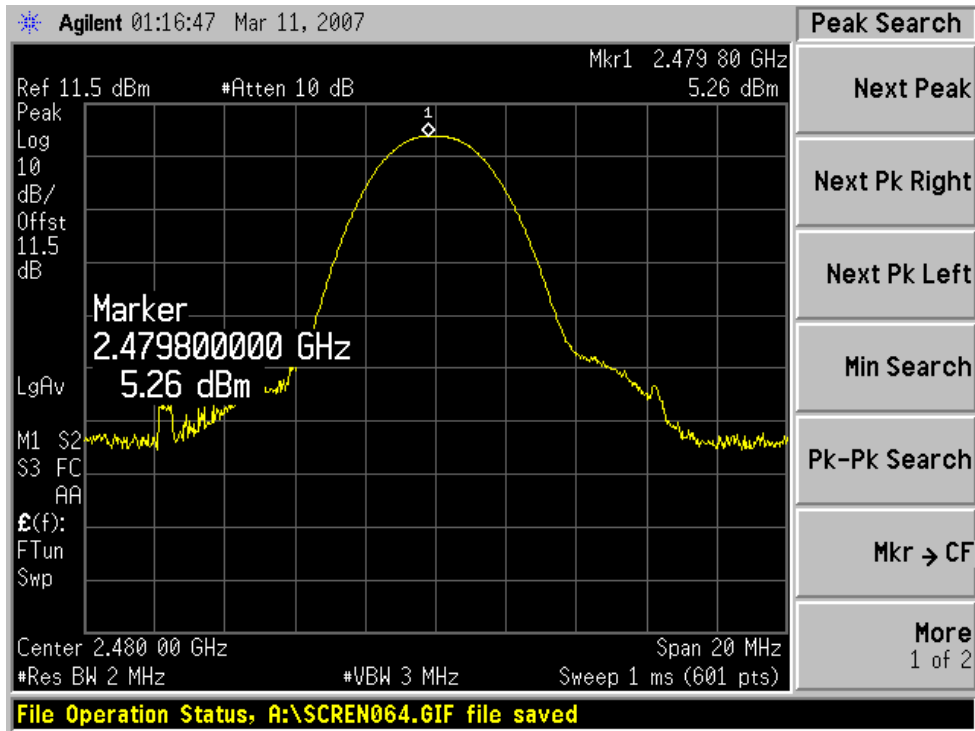

13 §15.247 (d) - 100 KHz BANDWIDTH OF BAND EDGES

13.1 Applicable Standard

According to §15.247(d), in any 100 kHz bandwidth outside the frequency band in which the spread spectrum intentional radiator is operating, the radio frequency power that is produced by the intentional radiator shall be at least 20 dB below that in the 100 kHz bandwidth within the band that contains the highest level of the desired power, based on either an RF conducted or a radiated measurement. Attenuation below the general limits specified in §15.209(a) is not required.

13.2 Measurement Procedure

1. Check the calibration of the measuring instrument using either an internal calibrator or a known signal from an external generator.
2. Position the EUT without connection to measurement instrument. Turn on the EUT and connect its antenna terminal to measurement instrument via a low loss cable. Then set it to any one measured frequency within its operating range, and make sure the instrument is operated in its linear range.
3. Set both RBW and VBW of spectrum analyzer to 100 kHz with a convenient frequency span including 100 kHz bandwidth from band edge.
4. Measure the highest amplitude appearing on spectral display and set it as a reference level. Plot the graph with marking the highest point and edge frequency.
5. Repeat above procedures until all measured frequencies were complete.

13.3 Test Equipment List and Details

Manufacturer	Description	Model Number	Serial Number	Calibration Date
Agilent	Analyzer, Spectrum	E4446A	US44300386	2006-04-26

* **Statement of Traceability: BA CL Corp.** attests that all calibrations have been performed per the NVLAP requirements, traceable to the NIST.

13.4 Test Setup Diagram

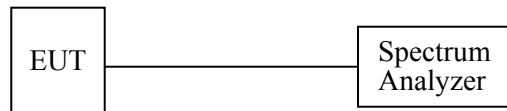

Environmental Conditions

Temperature:	23 °C
Relative Humidity:	40 %
ATM Pressure:	102.0 kPa

*The testing was performed by James Ma on 2007-04-13.

Please refer to the following plots for results.

13.5 Plots of 100 KHz Bandwidth of Band Edge

Low Channel

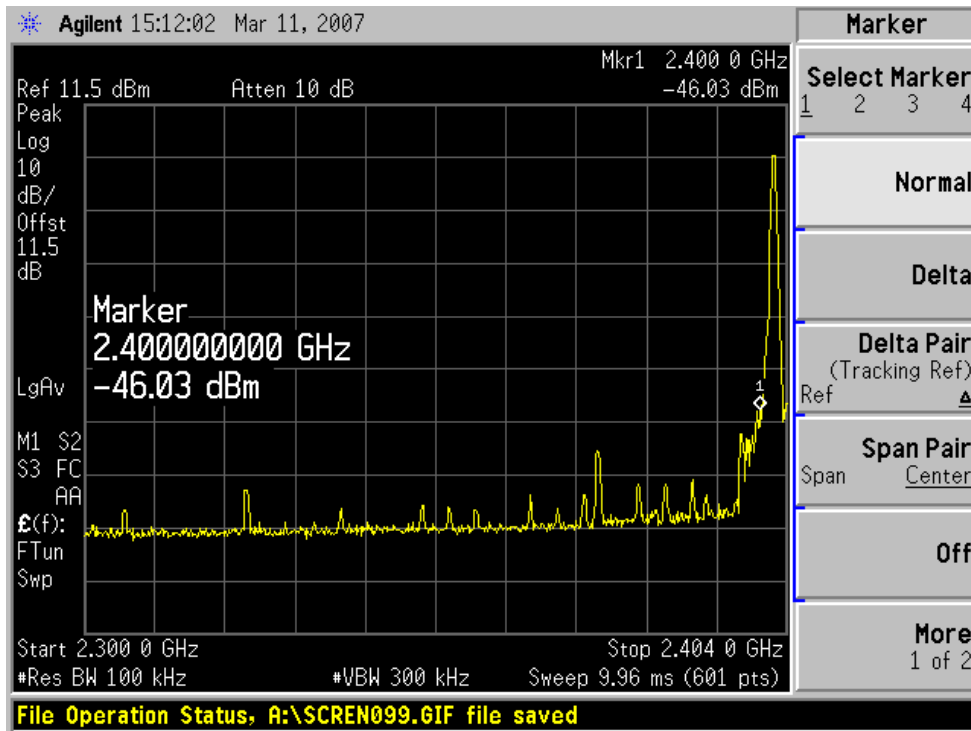

High Channel

