



EMISSIONS TEST REPORT

Report Number: 100514149BOX-003c

Project Number: G100514149

Report Issue Date: 10/14/2011

Product Designation: Load Transmitter and Receiver in POWER-LOAD System

Standards: CFR47 FCC Part 15:2011 Subpart C Section 15.225,
Industry Canada RSS-210 Issue 8 December 2010, Annex 2 (A2.6)
Industry Canada RSS-Gen Issue 3 December 2010

Tested by:
Intertek Testing Services NA, Inc.
70 Codman Hill Road
Boxborough, MA 01719

Client:
Stryker Medical
3800 E. Centre Avenue
Portage, MI 49002

Report prepared by

Kouma Sinn / Senior Project Engineer

Report reviewed by

Michael F. Murphy / EMC Staff Engineer

This report is for the exclusive use of Intertek's Client and is provided pursuant to the agreement between Intertek and its Client. Intertek's responsibility and liability are limited to the terms and conditions of the agreement. Intertek assumes no liability to any party, other than to the Client in accordance with the agreement, for any loss, expense or damage occasioned by the use of this report. Only the Client is authorized to permit copying or distribution of this report and then only in its entirety. Any use of the Intertek name or one of its marks for the sale or advertisement of the tested material, product or service must first be approved in writing by Intertek. The observations and test results in this report are relevant only to the sample tested. This report by itself does not imply that the material, product, or service is or has ever been under an Intertek certification program.

1 Introduction and Conclusion

The tests indicated in section 2.0 were performed on the product constructed as described in section 3.0. The remaining test sections are the verbatim text from the actual data sheets used during the investigation. These test sections include the test name, the specified test Method, a list of the actual Test Equipment Used, documentation Photos, Results and raw Data. No additions, deviations, or exclusions have been made from the standard(s) unless specifically noted.

Based on the results of our investigation, we have concluded the product tested **complies** with the requirements of the standard(s) indicated. The results obtained in this test report pertain only to the item(s) tested.

2 Test Summary

Section	Test full name	Result
3	Client Information	--
4	Description of Equipment Under Test	--
5	System Setup and Method	--
6	Fundamental Radiated Emissions FCC Part 15:2011 Subpart C 15.225(a), (b), (c), (d) IC RSS-210 Issue 8 December 2010 A2.6 (a), (b), (c), (d)	Pass
7	Transmitter Spurious Emissions Below 30MHz FCC Part 15:2011 Subpart C 15.209, 15.225(d), IC RSS-210 Issue 8 December 2010 A2.6(d)	Pass
8	Transmitter Spurious Emissions Above 30MHz FCC Part 15:2011 Subpart C 15.209, 15.225(d), IC RSS-210 Issue 8 December 2010 A2.6(d)	Pass
--	Receiver Spurious Emissions Below 30MHz FCC Part 15:2011 Subpart B 15.109, IC RSS-Gen Issue 3 December 2010: Section 6.0	N/A*
9	Receiver Spurious Emissions Above 30MHz FCC Part 15:2011 Subpart B 15.109, IC RSS-Gen Issue 3 December 2010: Section 6.0	Pass
10	20dB Bandwidth FCC Part 15:2011 Subpart C 15.215 IC RSS-Gen Issue 3 December 2010 Section 4.6	Pass
11	Frequency Stability FCC Part 15:2011 Subpart C 15.225(e), IC RSS-Gen Issue 3 December 2010 Section 4.7 IC RSS-210 December 2010 A2.6	Pass
12	Revision History	--

* - no limits below 30 MHz

3 Client Information

This EUT was tested at the request of:

Company: Stryker Medical
 3800 E. Centre Avenue
 Portage, MI 49002

Contact: Mr. Peter Schultz

Telephone: (269) 488-6415

Fax: (269) 329-2260

Email: peter.schultz@stryker.com

4 Description of Equipment Under Test

Equipment Under Test			
Description	Manufacturer	Model Number	Serial Number
Load (Transmitter)	Stryker Medical	6390	110841451
Load (Receiver)	Stryker Medical	6390	45305079
Load (Un-modulated)	Stryker Medical	6390	45305067

Receive Date:	10/03/2011
Received Condition:	Good
Type:	Production

Description of Equipment Under Test (provided by client)

The Power-LOAD ambulance cot fastener is a new product designed to reduce EMT workload by eliminating the need to lift a cot into the back of the ambulance. The EUT consists of Power-Load, Model 6390 tested in a standalone configuration. The Load portion of the system contains a 13.56 MHz transceiver which is used to communicate with the Power-Pro XT (cot).

Equipment Under Test Power Configuration			
Rated Voltage	Rated Current	Rated Frequency	Number of Phases
12-16 VDC	10 A	DC	DC

Operating modes of the EUT:	
No.	Descriptions of EUT Exercising
1	During testing, the 13.56 MHz transmitter was operating as near to continuously as possible, except in receive mode where the transmitter was idle and waiting for messages. A modulated carrier was used, except for frequency stability testing where a standalone comm. board was used.

5 System Setup and Method

Cables					
ID	Description	Length (m)	Shielding	Ferrites	Termination
	None				

Support Equipment			
Description	Manufacturer	Model Number	Serial Number
None			

5.1 Method:

Configuration as required by ANSI C63.4-2003

5.2 EUT Block Diagram:

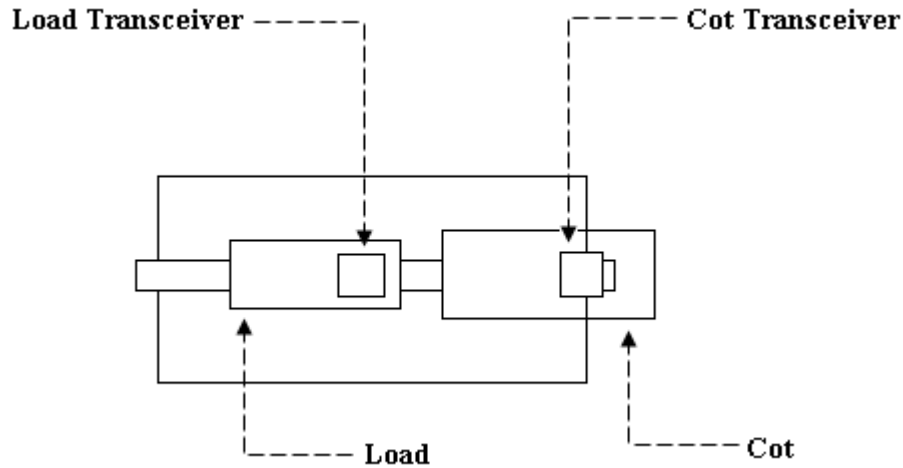

6 Fundamental Frequency Radiated Emissions

6.1 Method

Tests are performed in accordance with FCC Part 15:2011 Subpart C 15.225(a), (b), (c), (d), IC RSS-210 Issue 8 December 2010 A2.6 (a), (b), (c), (d), ANSI C63.4-2003.

TEST SITE: 10m ALSE

The 10m ALSE is 13m (Length) x 21m (Depth) x 10m (Height) with the effective size in terms of space from the tips of the absorber is 12m (Length) x 20m (Depth) x 8.5m (Height). This chamber achieves broadband performance using a unique arrangement of hybrid and ferrite tile absorber. This chamber has a built in 3m diameter turntable (Embedded type). The metal structure of the table makes electrical connection around the entire circumference of the turntable to the ground plane with a metal brush type connection. The turntable is located on one end of the chamber and the antennas are mounted 3 and 10 meters away at the other end of the chamber on the adjustable an Antenna Mast. The antenna mast is a non-conductive bore sighted type with remote control of antenna height and polarization. The Antenna Mast and the turntable can be remotely controlled through the controller located in the adjacent Control room. A wooden table 80 cm high is used for table-top equipment.

Measurement Uncertainty

For radiated emissions, U_{lab} (3.5 dB at 3m and 3.5 dB at 10m below 1 GHz, and 4.2 dB at 3m above 1 GHz) < U_{CISPR} (5.2 dB), which is the reference value in CISPR 16-4-2 Table 1, hence the compliance of the product is only based on the measured value, and no measurement uncertainty correction is required, based on CISPR 22 and CISPR 11 (for 2006 and later revisions) Clause 11.

Sample Calculation

The field strength is calculated by adding the Antenna Factor and Cable Factor, and subtracting the Amplifier Gain (if any) from the measured reading. The basic equation with a sample calculation is as follows:

$$FS = RA + AF + CF - AG$$

Where

- FS = Field Strength in dB μ V/m
- RA = Receiver Amplitude (including preamplifier) in dB μ V
- CF = Cable Attenuation Factor in dB
- AF = Antenna Factor in dB
- AG = Amplifier Gain in dB

In the following table(s), the reading shown on the data table reflects the preamplifier gain. An example for the calculations in the following table is as follows.

Assume a receiver reading of 52.0 dB μ V is obtained. The antenna factor of 7.4 dB and cable factor of 1.6 dB is added. The amplifier gain of 29 dB is subtracted, giving a field strength of 32 dB μ V/m. This value in dB μ V/m was converted to its corresponding level in μ V/m.

RA = 52.0 dB μ V
 AF = 7.4 dB/m
 CF = 1.6 dB
 AG = 29.0 dB
 FS = 32 dB μ V/m

To convert from dB μ V to μ V or mV the following was used:

$$UF = 10^{(NF / 20)} \text{ where } UF = \text{Net Reading in } \mu\text{V}$$

$$NF = \text{Net Reading in dB}\mu\text{V}$$

Example:

$$FS = RA + AF + CF - AG = 52.0 + 7.4 + 1.6 - 29.0 = 32.0$$

$$UF = 10^{(32 \text{ dB}\mu\text{V} / 20)} = 39.8 \mu\text{V/m}$$

6.2 Test Equipment Used:

Asset	Description	Manufacturer	Model	Serial	Cal Date	Cal Due
DAV003'	Weather Station	Davis Instruments	7400	PE80529A39A	08/02/2011	08/02/2012
145019'	Active Loop Antenna (10 khz to 30 mhz)	EMCO	6502/1	9902-3267	12/18/2010	12/18/2011
145-416'	Cables 145-400 145-402 145-404 145-408	Huber + Suhner	3m Track B cables	multiple	09/04/2011	09/04/2012
145128'	EMI Receiver 40 GHz (20 Hz - 40 Ghz)	Rohde & Schwarz	ESI	8392831001	08/23/2011	08/23/2012

Software Utilized:

Name	Manufacturer	Version
EMI Boxborough.xls	Intertek	08/27/10

6.3 Results:

The sample tested was found compliant.

The field strength of any emissions shall not exceed the limits as follows:

Frequency Bands (MHz)	Field Strength Limits		Test Distance (meters)
	$\mu\text{V/m}$	$\text{dB}\mu\text{V/m}$	
13.553 –13.567	15,848	84.00	30
13.410 –13.553	334	50.50	30
13.567 –13.710	334	50.50	30
13.110 –13.410	106	40.51	30
13.710 –14.010	106	40.51	30
Outside of 13.110 –14.010	§15.209		

6.4 Setup Photographs:

Fundamental and Offset Frequencies Test Setup Photo # 1

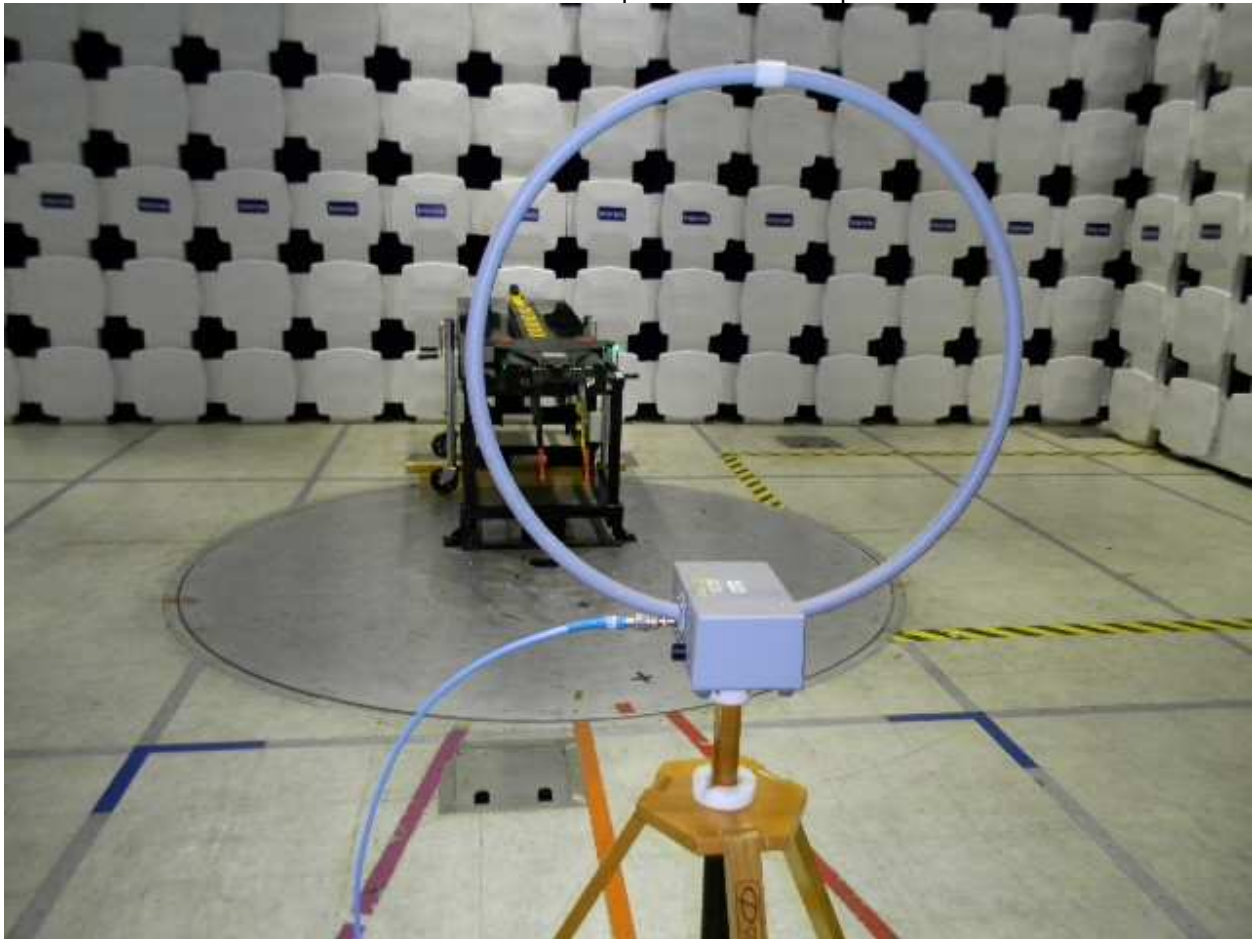

Fundamental and Offset Frequencies Test Setup Photo # 2



7 Transmitter Spurious Emissions Below 30 MHz

7.1 Method

Tests are performed in accordance with FCC Part 15:2011 Subpart C 15.209, 15.225(d), IC RSS-210 Issue 8 December 2010 A2.6(d), ANSI C63.4-2003.

TEST SITE: 10m ALSE

The 10m ALSE is 13m (Length) x 21m (Depth) x 10m (Height) with the effective size in terms of space from the tips of the absorber is 12m (Length) x 20m (Depth) x 8.5m (Height). This chamber achieves broadband performance using a unique arrangement of hybrid and ferrite tile absorber. This chamber has a built in 3m diameter turntable (Embedded type). The metal structure of the table makes electrical connection around the entire circumference of the turntable to the ground plane with a metal brush type connection. The turntable is located on one end of the chamber and the antennas are mounted 3 and 10 meters away at the other end of the chamber on the adjustable an Antenna Mast. The antenna mast is a non-conductive bore sighted type with remote control of antenna height and polarization. The Antenna Mast and the turntable can be remotely controlled through the controller located in the adjacent Control room. A wooden table 80 cm high is used for table-top equipment.

Measurement Uncertainty

For radiated emissions, U_{lab} (3.5 dB at 3m and 3.5 dB at 10m below 1 GHz, and 4.2 dB at 3m above 1 GHz) < U_{CISPR} (5.2 dB), which is the reference value in CISPR 16-4-2 Table 1, hence the compliance of the product is only based on the measured value, and no measurement uncertainty correction is required, based on CISPR 22 and CISPR 11 (for 2006 and later revisions) Clause 11.

Sample Calculation

The field strength is calculated by adding the Antenna Factor and Cable Factor, and subtracting the Amplifier Gain (if any) from the measured reading. The basic equation with a sample calculation is as follows:

$$FS = RA + AF + CF - AG$$

Where

- FS = Field Strength in dB μ V/m
- RA = Receiver Amplitude (including preamplifier) in dB μ V
- CF = Cable Attenuation Factor in dB
- AF = Antenna Factor in dB
- AG = Amplifier Gain in dB

In the following table(s), the reading shown on the data table reflects the preamplifier gain. An example for the calculations in the following table is as follows.

Assume a receiver reading of 52.0 dB μ V is obtained. The antenna factor of 7.4 dB and cable factor of 1.6 dB is added. The amplifier gain of 29 dB is subtracted, giving a field strength of 32 dB μ V/m. This value in dB μ V/m was converted to its corresponding level in μ V/m.

RA = 52.0 dB μ V
 AF = 7.4 dB/m
 CF = 1.6 dB
 AG = 29.0 dB
 FS = 32 dB μ V/m

To convert from dB μ V to μ V or mV the following was used:

$$UF = 10^{(NF / 20)} \text{ where } UF = \text{Net Reading in } \mu\text{V}$$

$$NF = \text{Net Reading in dB}\mu\text{V}$$

Example:

$$FS = RA + AF + CF - AG = 52.0 + 7.4 + 1.6 - 29.0 = 32.0$$

$$UF = 10^{(32 \text{ dB}\mu\text{V} / 20)} = 39.8 \mu\text{V/m}$$

7.2 Test Equipment Used:

Asset	Description	Manufacturer	Model	Serial	Cal Date	Cal Due
DAV003'	Weather Station	Davis Instruments	7400	PE80529A39A	08/02/2011	08/02/2012
145019'	Active Loop Antenna (10 khz to 30 mhz)	EMCO	6502/1	9902-3267	12/18/2010	12/18/2011
145-416'	Cables 145-400 145-402 145-404 145-408	Huber + Suhner	3m Track B cables	multiple	09/04/2011	09/04/2012
145128'	EMI Receiver 40 GHz (20 Hz - 40 Ghz)	Rohde & Schwarz	ESI	8392831001	08/23/2011	08/23/2012

Software Utilized:

Name	Manufacturer	Version
EMI Boxborough.xls	Intertek	08/27/10

7.3 Results:

The sample tested was found compliant.

The field strength of any emissions shall not exceed the limits as follows:

FCC Part 15.209

Frequency (MHz)	Field Strength		Test Distance (meters)
	$\mu\text{V}/\text{m}$	$\text{dB}\mu\text{V}/\text{m}$	
0.009–0.490	2400/F(kHz)	20*Log(2400/F(kHz))	300
0.490–1.705	24000/F(kHz)	20*Log(24000/F(kHz))	30
1.705–30.0	30.00	29.54	30

Note: The emission limits for the bands 9-90 kHz and 110-490 kHz are based on measurements employing an average detector.

IC RSS-210 A2.6(d): emissions outside the band 13.110-14.010 MHz must not exceed 30 microvolts/m (29.5 dB $\mu\text{V}/\text{m}$) at 30 m.

7.4 Setup Photographs:

9 kHz-30 MHz Test Setup Photo # 1

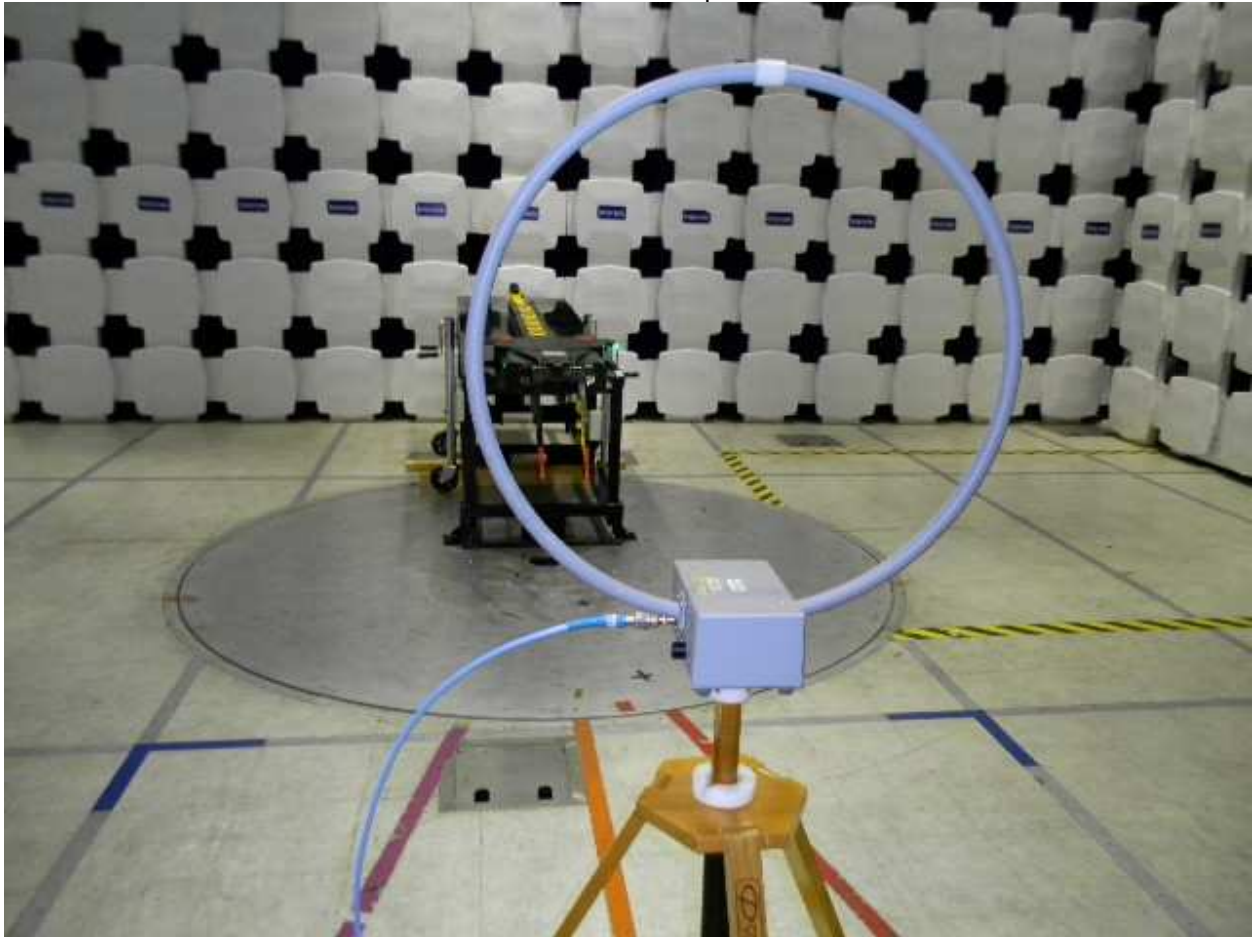

9 kHz-30 MHz Test Setup Photo # 2

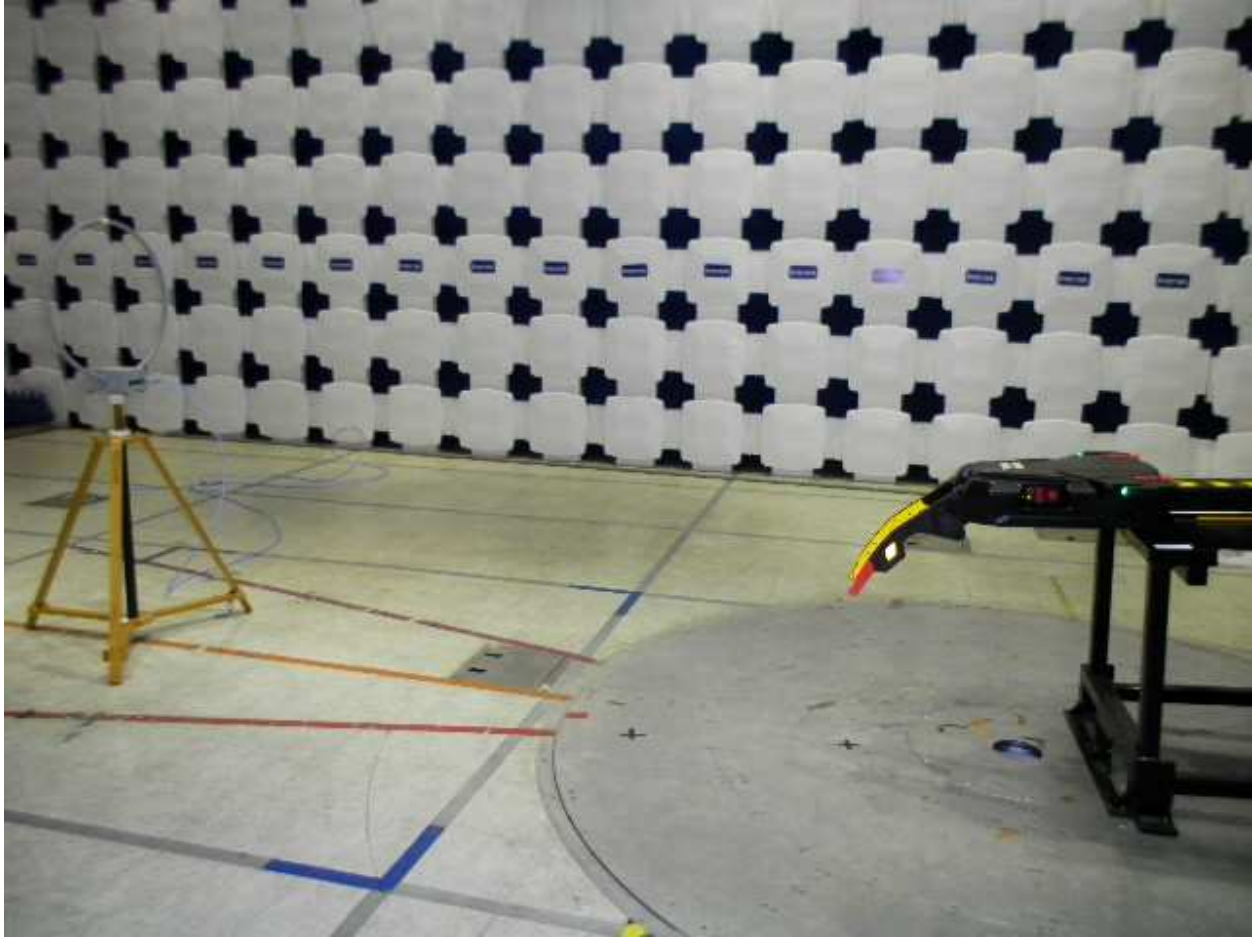

8 Transmitter Spurious Above 30 MHz

8.1 Method

Tests are performed in accordance with FCC Part 15:2011 Subpart C 15.209, 15.225(d), IC RSS-210 Issue 8 December 2010 A2.6(d), ANSI C63.4-2003.

TEST SITE: 10m ALSE

The 10m ALSE is 13m (Length) x 21m (Depth) x 10m (Height) with the effective size in terms of space from the tips of the absorber is 12m (Length) x 20m (Depth) x 8.5m (Height). This chamber achieves broadband performance using a unique arrangement of hybrid and ferrite tile absorber. This chamber has a built in 3m diameter turntable (Embedded type). The metal structure of the table makes electrical connection around the entire circumference of the turntable to the ground plane with a metal brush type connection. The turntable is located on one end of the chamber and the antennas are mounted 3 and 10 meters away at the other end of the chamber on the adjustable an Antenna Mast. The antenna mast is a non-conductive bore sighted type with remote control of antenna height and polarization. The Antenna Mast and the turntable can be remotely controlled through the controller located in the adjacent Control room. A wooden table 80 cm high is used for table-top equipment.

Measurement Uncertainty

For radiated emissions, U_{lab} (3.5 dB at 3m and 3.5 dB at 10m below 1 GHz, and 4.2 dB at 3m above 1 GHz) < U_{CISPR} (5.2 dB), which is the reference value in CISPR 16-4-2 Table 1, hence the compliance of the product is only based on the measured value, and no measurement uncertainty correction is required, based on CISPR 22 and CISPR 11 (for 2006 and later revisions) Clause 11.

Sample Calculation

The field strength is calculated by adding the Antenna Factor and Cable Factor, and subtracting the Amplifier Gain (if any) from the measured reading. The basic equation with a sample calculation is as follows:

$$FS = RA + AF + CF - AG$$

Where

- FS = Field Strength in dB μ V/m
- RA = Receiver Amplitude (including preamplifier) in dB μ V
- CF = Cable Attenuation Factor in dB
- AF = Antenna Factor in dB
- AG = Amplifier Gain in dB

In the following table(s), the reading shown on the data table reflects the preamplifier gain. An example for the calculations in the following table is as follows.

Assume a receiver reading of 52.0 dB μ V is obtained. The antenna factor of 7.4 dB and cable factor of 1.6 dB is added. The amplifier gain of 29 dB is subtracted, giving a field strength of 32 dB μ V/m. This value in dB μ V/m was converted to its corresponding level in μ V/m.

RA = 52.0 dB μ V
 AF = 7.4 dB/m
 CF = 1.6 dB
 AG = 29.0 dB
 FS = 32 dB μ V/m

To convert from dB μ V to μ V or mV the following was used:

$$UF = 10^{(NF / 20)} \text{ where } UF = \text{Net Reading in } \mu\text{V}$$

$$NF = \text{Net Reading in dB}\mu\text{V}$$

Example:

$$FS = RA + AF + CF - AG = 52.0 + 7.4 + 1.6 - 29.0 = 32.0$$

$$UF = 10^{(32 \text{ dB}\mu\text{V} / 20)} = 39.8 \mu\text{V/m}$$

8.2 Test Equipment Used:

Asset	Description	Manufacturer	Model	Serial	Cal Date	Cal Due
-DAV003	Weather Station	Davis Instruments	7400	PE80529A39A	08/02/2011	08/02/2012
-145128	EMI Receiver 40 GHz (20 Hz - 40 Ghz)	Rohde & Schwarz	ESI	8392831001	08/23/2011	08/23/2012
-145106	Bilog Antenna (30MHz - 5GHz)	Sunol Sciences	JB5	A111003	08/15/2011	08/15/2012
-145-410	Cables 145-400 145-403 145-405 145-406 145-407	Huber + Suhner	10m Track A Cables	multiple	09/04/2011	09/04/2012
-PRE7	PREAMPLIFIER	Hewlett Packard	8447D	2944A08718	07/01/2011	07/01/2012

Software Utilized:

Name	Manufacturer	Version
C5	Teseq	Build 5.26.00.3

8.3 Results:

The sample was tested found compliant.

The field strength of any emissions shall not exceed the limits as follows:

FCC Part 15.209

Frequency (MHz)	Field Strength		Test Distance (meters)
	$\mu\text{V}/\text{m}$	$\text{dB}\mu\text{V}/\text{m}$	
30–88	100	40.00	3
88–216	150	43.52	3
216–960	200	46.02	3
Above 960	500	53.98	3

IC RSS-210 A2.6(d): emissions outside the band 13.110-14.010 MHz must not exceed 30 microvolts/m (29.5 $\text{dB}\mu\text{V}/\text{m}$) at 30 m (49.5 $\text{dB}\mu\text{V}/\text{m}$ at 3m)

Since the IC RSS-210 limits are less stringent than the FCC 15.209 limits under 960 MHz, the FCC limits were used.

8.4 Setup Photographs:

30-1000MHz Test Setup Photo # 1

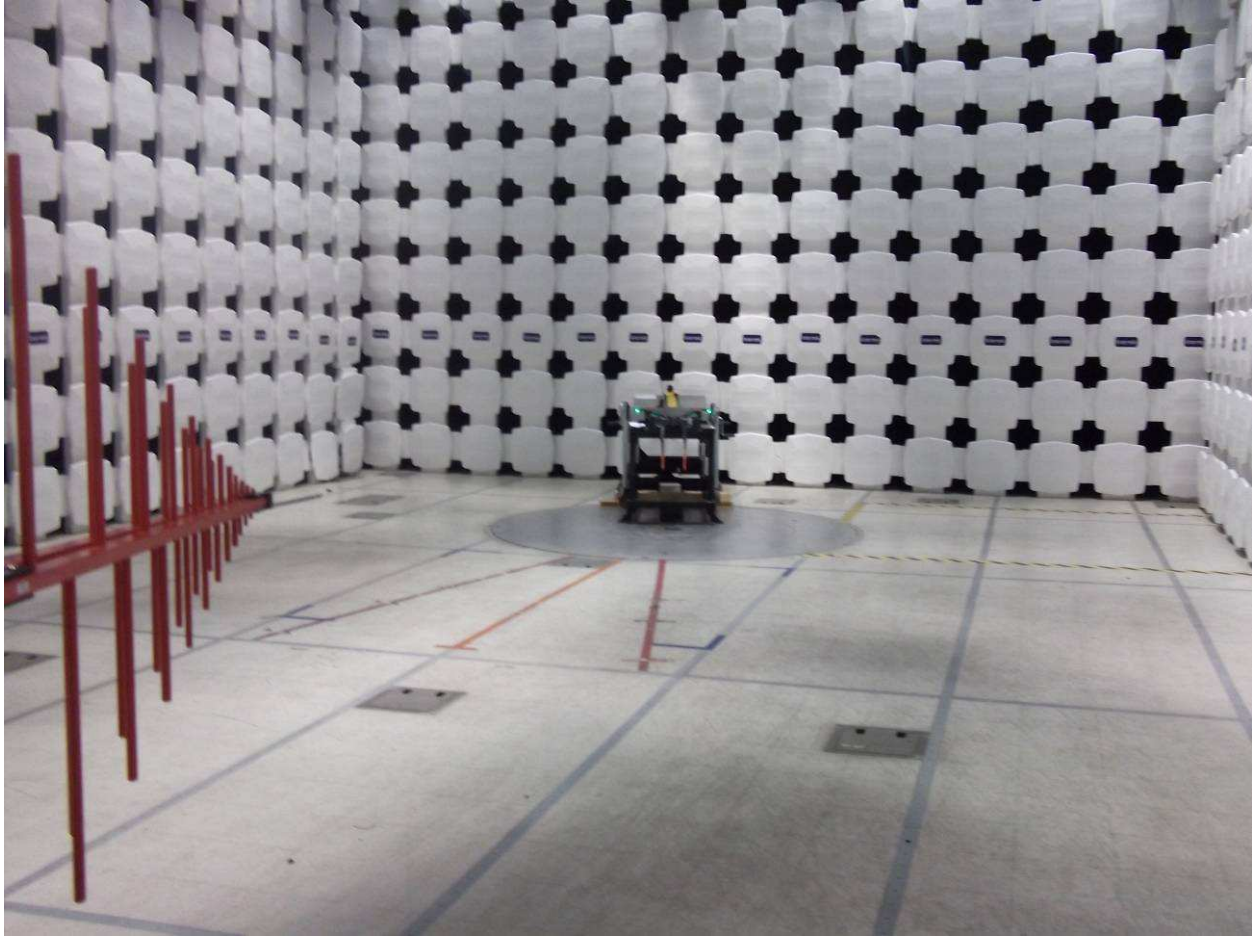

30-1000MHz Test Setup Photo # 2

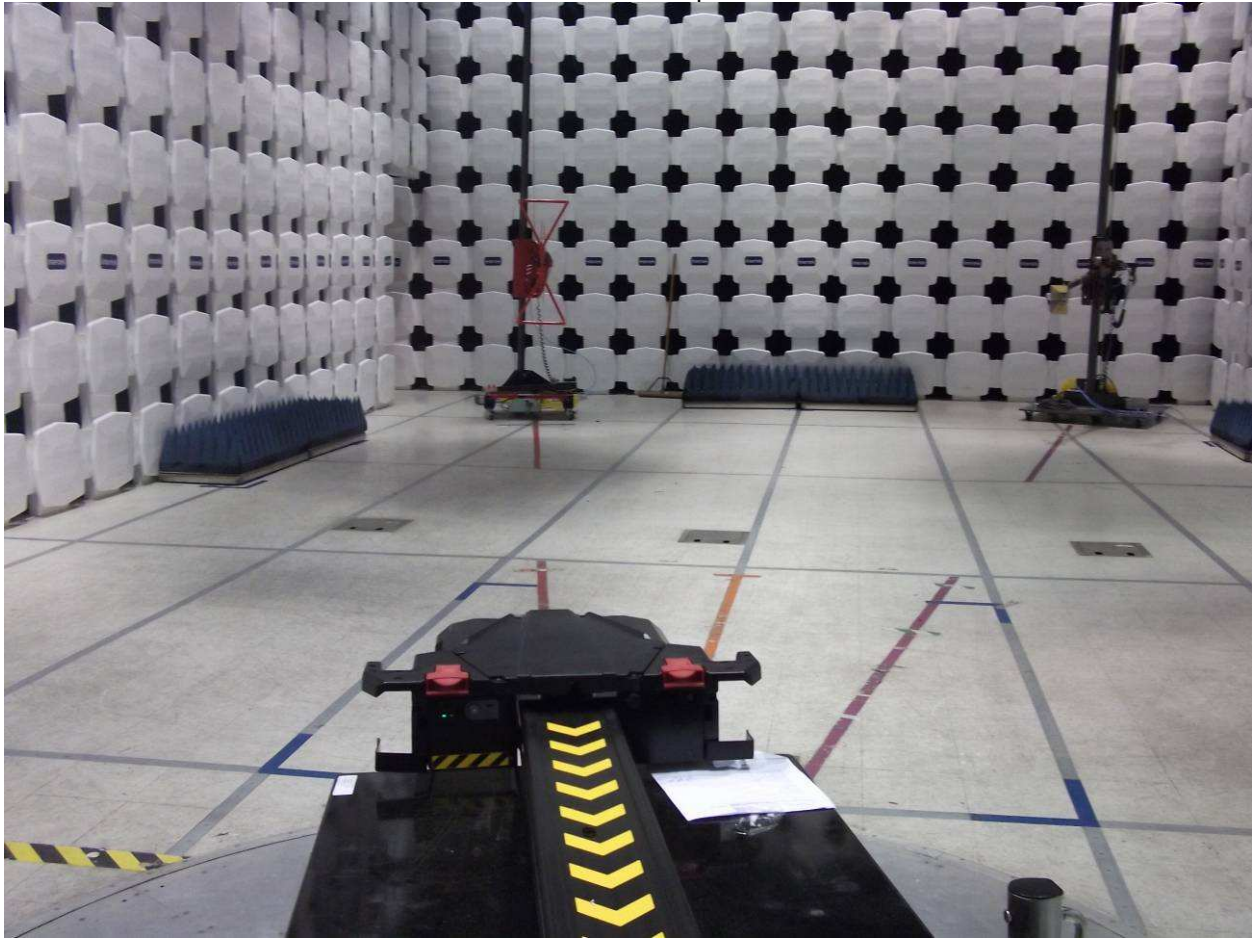

30-1000MHz Test Setup Photo # 3



8.5 Plots/Data:

Test Information

Test Details	User Input
Project:	Stryker G100514149
Test Notes:	1008mB; Load Tx Mode; Battery; Vertical
Temperature:	20c
Humidity:	52%
Tested by:	Nicholas Abbondante
Test Started:	Oct 5 2011 18 : 05

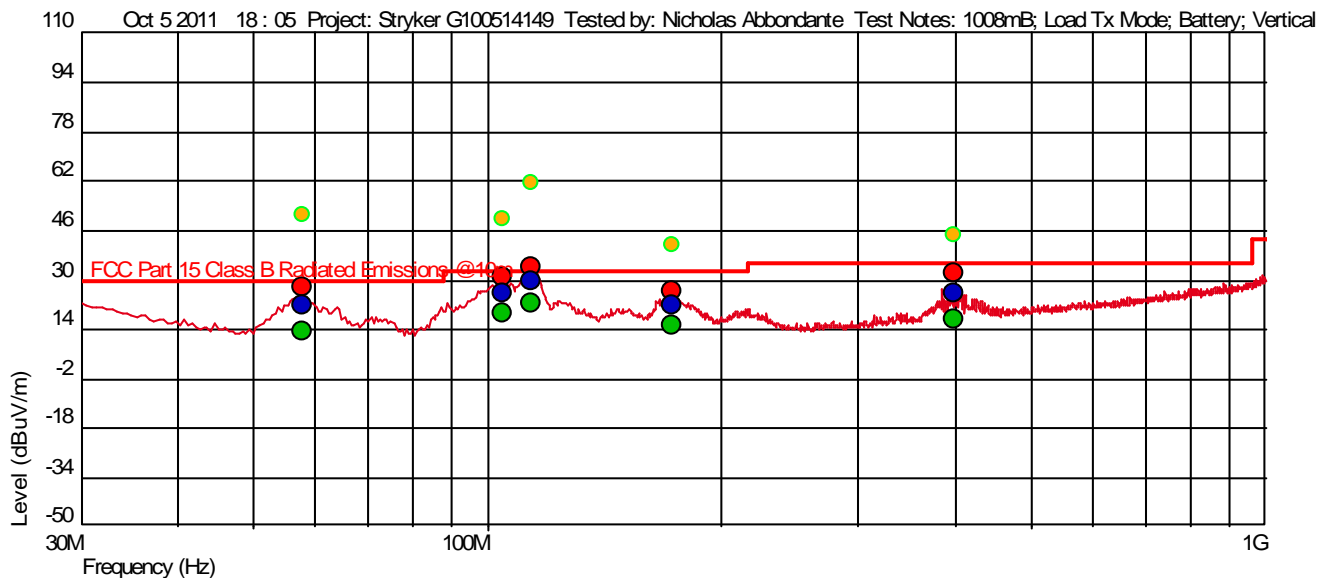

- Measured Peak Value
 - Measured Quasi Peak Value
 - Measured Average Value
 - Maximum Value of Mast and Turntable
- Level (dBuV/m) = AF + CL + PA + Raw
 AF = Antenna Factor
 CL = Cable Losses
 PA = Pre-Amplifier
 Raw = Raw Instrument Reading (Not listed on Spot Tables)

Measured: QP

Frequency (Hz)	Level* (dBuV/m)	AF	PA+CL	Limit (dBuV/m)	Margin (dBuV/m)	Hor (°), Ver (°)	Angle (Deg)	Mast Height (m)	Detector	RBW(Hz)
57.676 M	21.88	7.268	-25.907	29.54	-7.66		211	1.58	QP	120 k
104.627 M	25.49	11.426	-25.467	33.04	-7.55		309	2.58	QP	120 k
113.932 M	29.56	13.093	-25.331	33.04	-3.48		344	2.99	QP	120 k
172.920 M	21.82	11.992	-24.653	33.04	-11.22		296	1.19	QP	120 k
397.859 M	26.07	15.714	-23.853	35.54	-9.47		45	3.54	QP	120 k

Test Information

Test Details	User Input
Project:	Stryker G100514149
Test Notes:	1008mB; Load Tx Mode; Battery; Horizontal
Temperature:	20c
Humidity:	52%
Tested by:	Nicholas Abbondante
Test Started:	Oct 5 2011 19 : 18

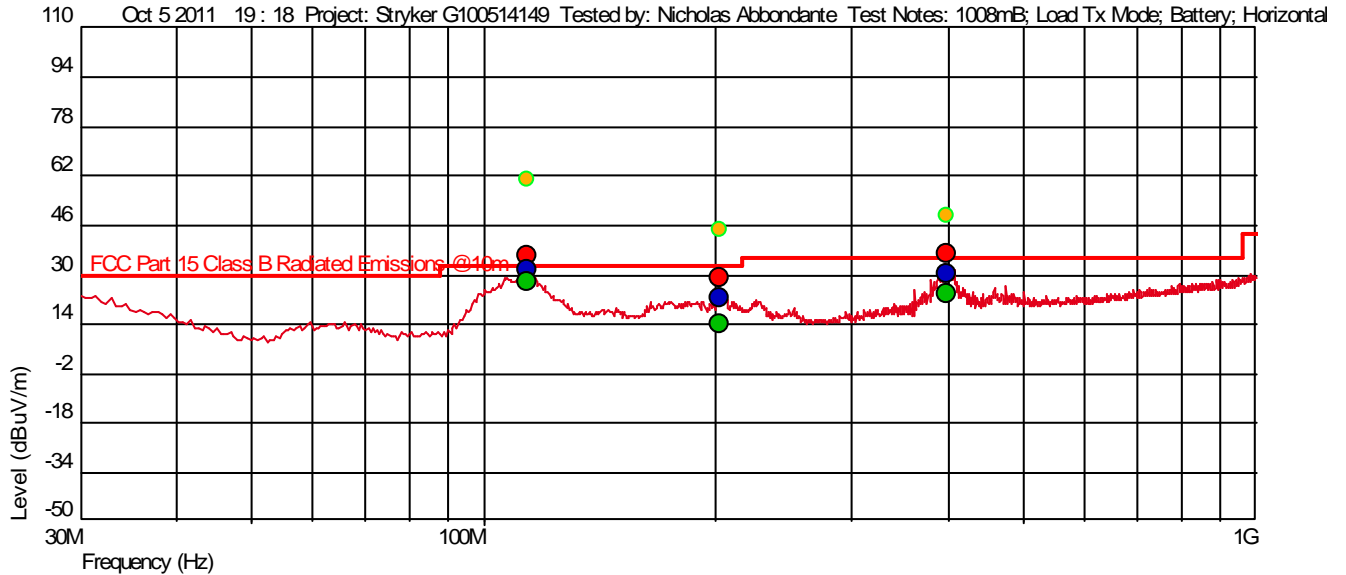

- Measured Peak Value
 - Measured Quasi Peak Value
 - Measured Average Value
 - Maximum Value of Mast and Turntable
- Level (dBuV/m) = AF + CL + PA + Raw
 AF = Antenna Factor
 CL = Cable Losses
 PA = Pre-Amplifier
 Raw = Raw Instrument Reading (Not listed on Spot Tables)

Measured: QP

Frequency (Hz)	Level* (dBuV/m)	AF	PA+CL	Limit (dBuV/m)	Margin (dBuV/m)	Hor (°), Ver (°)	Angle (Deg)	Mast Height (m)	Detector	RBW(Hz)
113.656 M	31.75	13.300	-25.335	33.04	-1.29	--	293	2.92	QP	120 k
202.358 M	22.83	11.851	-24.386	33.04	-10.21	--	324	3.95	QP	120 k
397.456 M	30.08	15.498	-23.851	35.54	-5.46	--	352	1.89	QP	120 k

Test Personnel(s): Nicholas Abbondante ~~NNA~~
Supervising Engineer: N/A
(Where Applicable)
Product Standard: FCC Part 15.225 and IC RSS-210
Input Voltage: 12 VDC Internal Battery
Pretest Verification w/
Ambient Signals or
BB Source: **Ambient Signals**

Test Date(s): 10/05/2011
Test Levels: See test results
Ambient Temperature: 20 °C
Relative Humidity: 52 %
Atmospheric Pressure: 1008 mbars

Deviations, Additions, or Exclusions: None

9 Receiver Spurious Emissions Above 30 MHz

9.1 Method

Tests are performed in accordance with FCC Part 15:2011 Subpart B 15.109, IC RSS-Gen Issue 3 December 2010: Section 6.0, ANSI C63.4-2003.

TEST SITE: 10m ALSE

The 10m ALSE is 13m (Length) x 21m (Depth) x 10m (Height) with the effective size in terms of space from the tips of the absorber is 12m (Length) x 20m (Depth) x 8.5m (Height). This chamber achieves broadband performance using a unique arrangement of hybrid and ferrite tile absorber. This chamber has a built in 3m diameter turntable (Embedded type). The metal structure of the table makes electrical connection around the entire circumference of the turntable to the ground plane with a metal brush type connection. The turntable is located on one end of the chamber and the antennas are mounted 3 and 10 meters away at the other end of the chamber on the adjustable an Antenna Mast. The antenna mast is a non-conductive bore sighted type with remote control of antenna height and polarization. The Antenna Mast and the turntable can be remotely controlled through the controller located in the adjacent Control room. A wooden table 80 cm high is used for table-top equipment.

Measurement Uncertainty

For radiated emissions, U_{lab} (3.5 dB at 3m and 3.5 dB at 10m below 1 GHz, and 4.2 dB at 3m above 1 GHz) < U_{CISPR} (5.2 dB), which is the reference value in CISPR 16-4-2 Table 1, hence the compliance of the product is only based on the measured value, and no measurement uncertainty correction is required, based on CISPR 22 and CISPR 11 (for 2006 and later revisions) Clause 11.

Sample Calculation

The field strength is calculated by adding the Antenna Factor and Cable Factor, and subtracting the Amplifier Gain (if any) from the measured reading. The basic equation with a sample calculation is as follows:

$$FS = RA + AF + CF - AG$$

Where

- FS = Field Strength in dB μ V/m
- RA = Receiver Amplitude (including preamplifier) in dB μ V
- CF = Cable Attenuation Factor in dB
- AF = Antenna Factor in dB
- AG = Amplifier Gain in dB

In the following table(s), the reading shown on the data table reflects the preamplifier gain. An example for the calculations in the following table is as follows.

Assume a receiver reading of 52.0 dB μ V is obtained. The antenna factor of 7.4 dB and cable factor of 1.6 dB is added. The amplifier gain of 29 dB is subtracted, giving a field strength of 32 dB μ V/m. This value in dB μ V/m was converted to its corresponding level in μ V/m.

RA = 52.0 dB μ V
 AF = 7.4 dB/m
 CF = 1.6 dB
 AG = 29.0 dB
 FS = 32 dB μ V/m

To convert from dB μ V to μ V or mV the following was used:

$$UF = 10^{(NF / 20)} \text{ where } UF = \text{Net Reading in } \mu\text{V}$$

$$NF = \text{Net Reading in dB}\mu\text{V}$$

Example:

$$FS = RA + AF + CF - AG = 52.0 + 7.4 + 1.6 - 29.0 = 32.0$$

$$UF = 10^{(32 \text{ dB}\mu\text{V} / 20)} = 39.8 \mu\text{V/m}$$

9.2 Test Equipment Used:

Asset	Description	Manufacturer	Model	Serial	Cal Date	Cal Due
-DAV003	Weather Station	Davis Instruments	7400	PE80529A39A	08/02/2011	08/02/2012
-145128	EMI Receiver 40 GHz (20 Hz - 40 Ghz)	Rohde & Schwarz	ESI	8392831001	08/23/2011	08/23/2012
-145106	Bilog Antenna (30MHz - 5GHz)	Sunol Sciences	JB5	A111003	08/15/2011	08/15/2012
-145-410	Cables 145-400 145-403 145-405 145-406 145-407	Huber + Suhner	10m Track A Cables	multiple	09/04/2011	09/04/2012
-PRE7	PREAMPLIFIER	Hewlett Packard	8447D	2944A08718	07/01/2011	07/01/2012

Software Utilized:

Name	Manufacturer	Version
C5	Teseq	Build 5.26.00.3

9.3 Results:

The sample tested was found compliant.

The field strength of any emissions shall not exceed the limits as follows:

FCC Part 15.209 & RSS-Gen:

Frequency (MHz)	Field Strength		Test Distance (meters)
	$\mu\text{V/m}$	$\text{dB}\mu\text{V/m}$	
30-88	100	40.00	3
88-216	150	43.52	3
216-960	200	46.02	3
Above 960	500	53.98	3

9.4 Setup Photographs:

30-1000MHz Test Setup Photo # 1

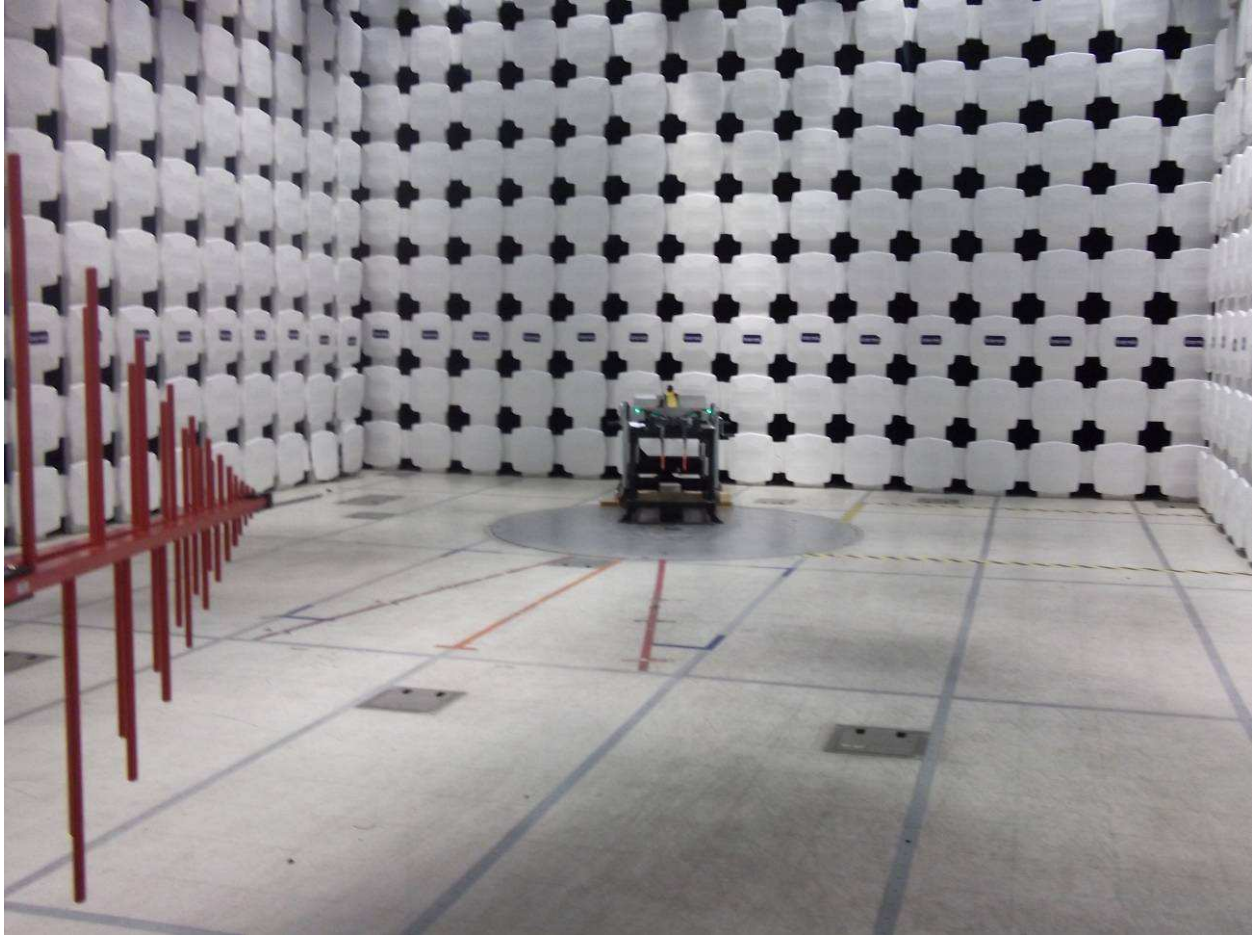

30-1000MHz Test Setup Photo # 2

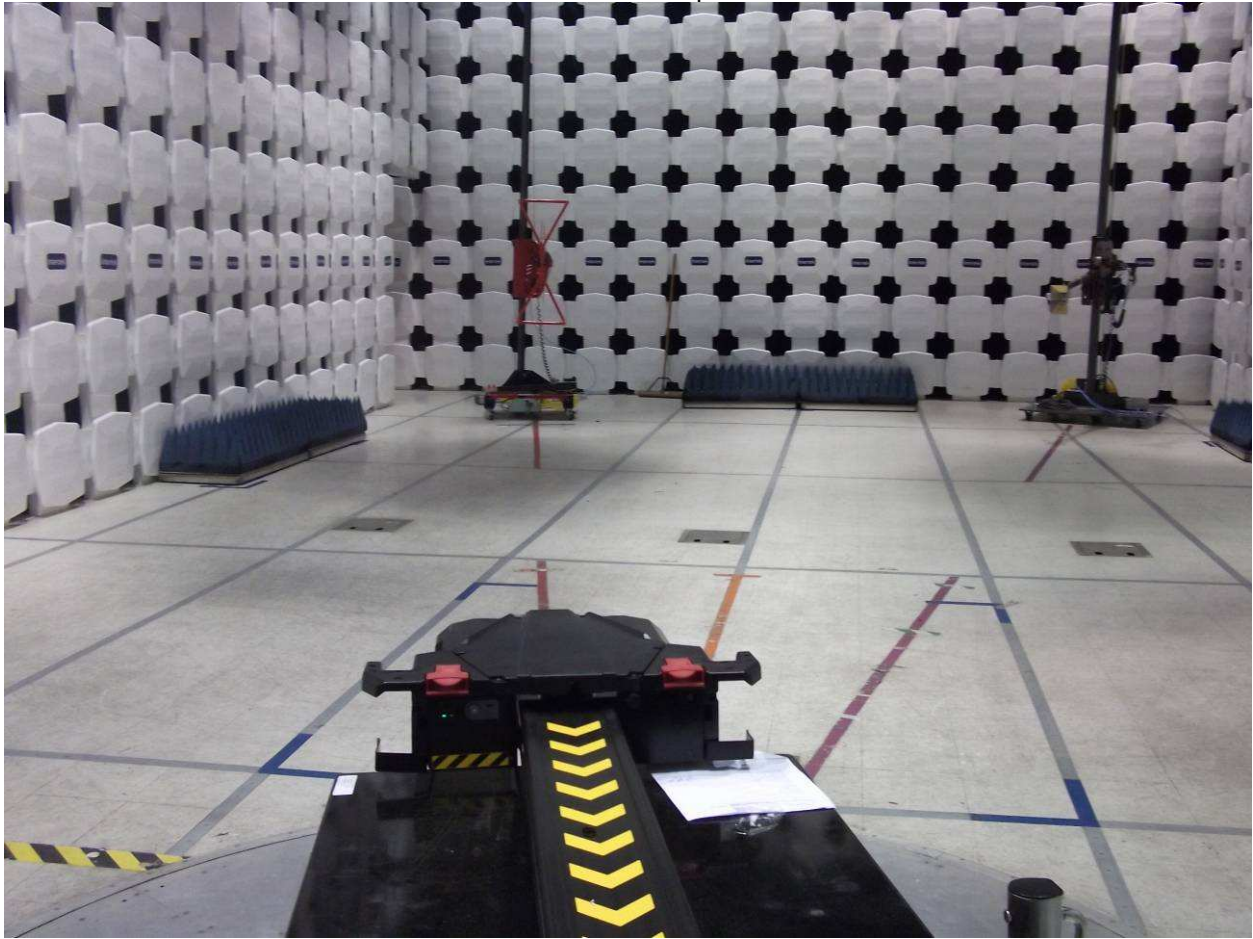

30-1000MHz Test Setup Photo # 3

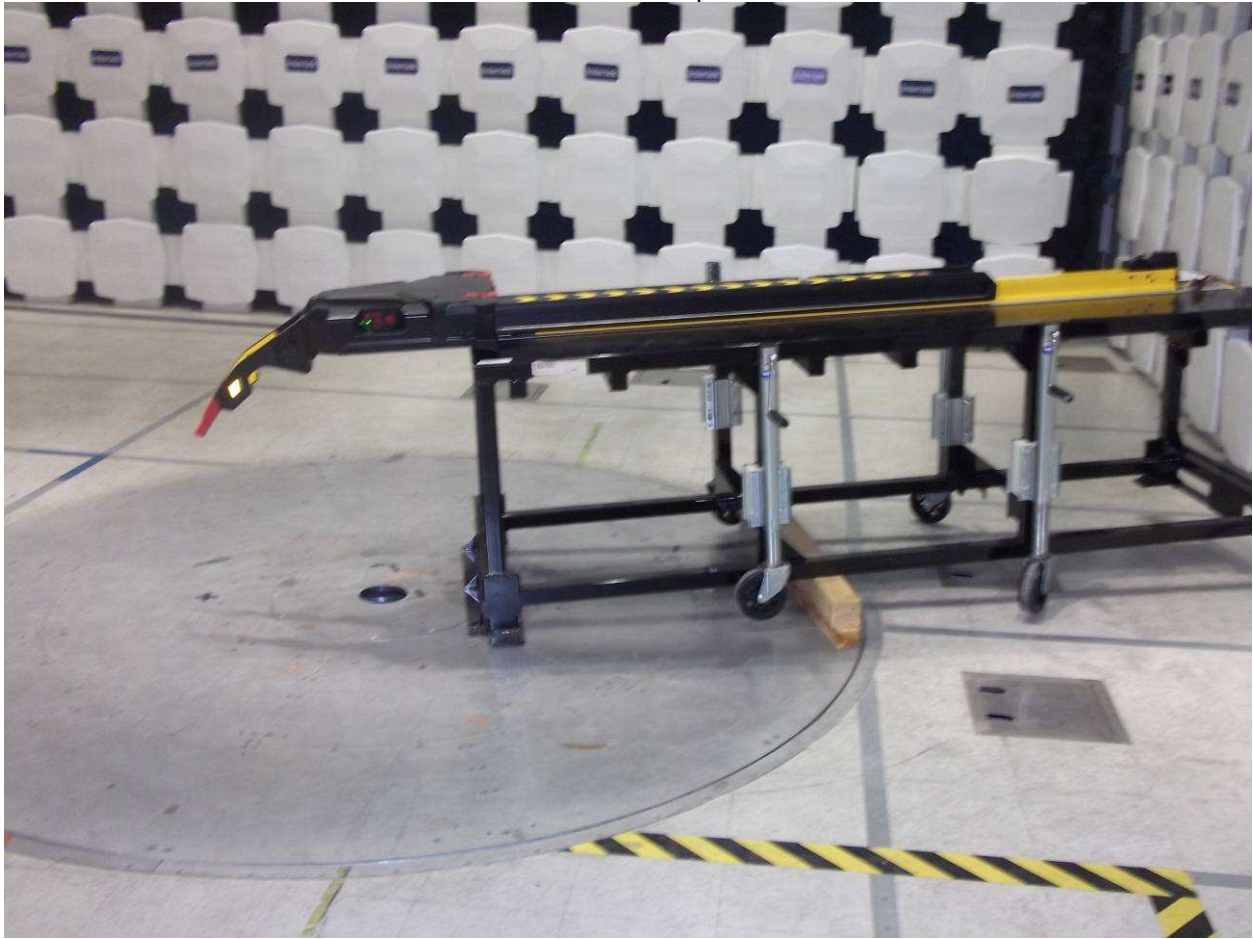

9.5 Plots/Data:

Test Information

Test Details	User Input
Project:	Stryker G100514149
Test Notes:	1008mB; Load Rx Mode; Battery; Vertical
Temperature:	20c
Humidity:	52%
Tested by:	Nicholas Abbondante
Test Started:	Oct 5 2011 20 : 55

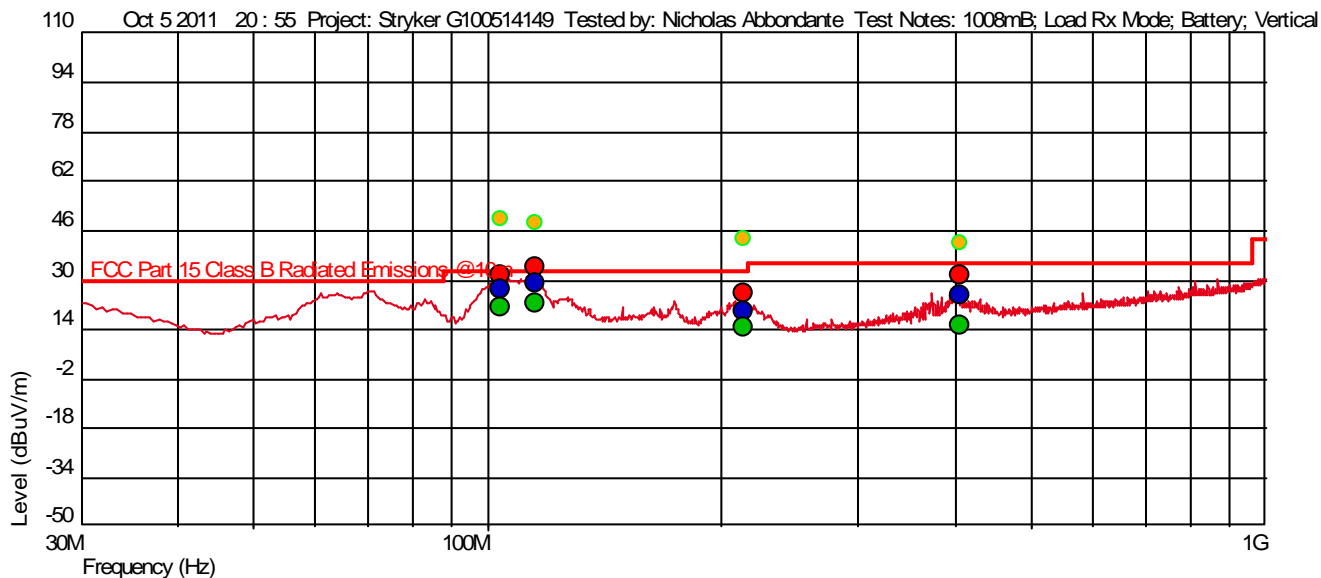

- Measured Peak Value
- Measured Quasi Peak Value
- Measured Average Value
- Maximum Value of Mast and Turntable

Level (dBuV/m) = AF + CL + PA + Raw
 AF = Antenna Factor
 CL = Cable Losses
 PA = Pre-Amplifier
 Raw = Raw Instrument Reading (Not listed on Spot Tables)

Measured: QP

Frequency (Hz)	Level*(dBuV/ m)	AF	PA+CL	Limit(dBuV/ m)	Margin(dBuV/ m)	Hor (--), Ver ()	Angle (Deg)	Mast Height (m)	Detector	RBW(Hz)
103.629 M	27.37	11.152	- 25.483	33.04	-5.67		290	2.39	QP	120 k
114.940 M	28.88	13.288	- 25.317	33.04	-4.16		6	2.52	QP	120 k
213.552 M	20.19	11.000	- 24.278	33.04	-12.85		275	1.66	QP	120 k
404.307 M	24.99	15.886	- 23.889	35.54	-10.55		41	4.00	QP	120 k

Test Information

Test Details User Input
 Project: Stryker G100514149
 Test Notes: 1008mB; Load Rx Mode; Battery; Horizontal
 Temperature: 20c
 Humidity: 52%
 Tested by: Nicholas Abbondante
 Test Started: Oct 5 2011 20 : 12

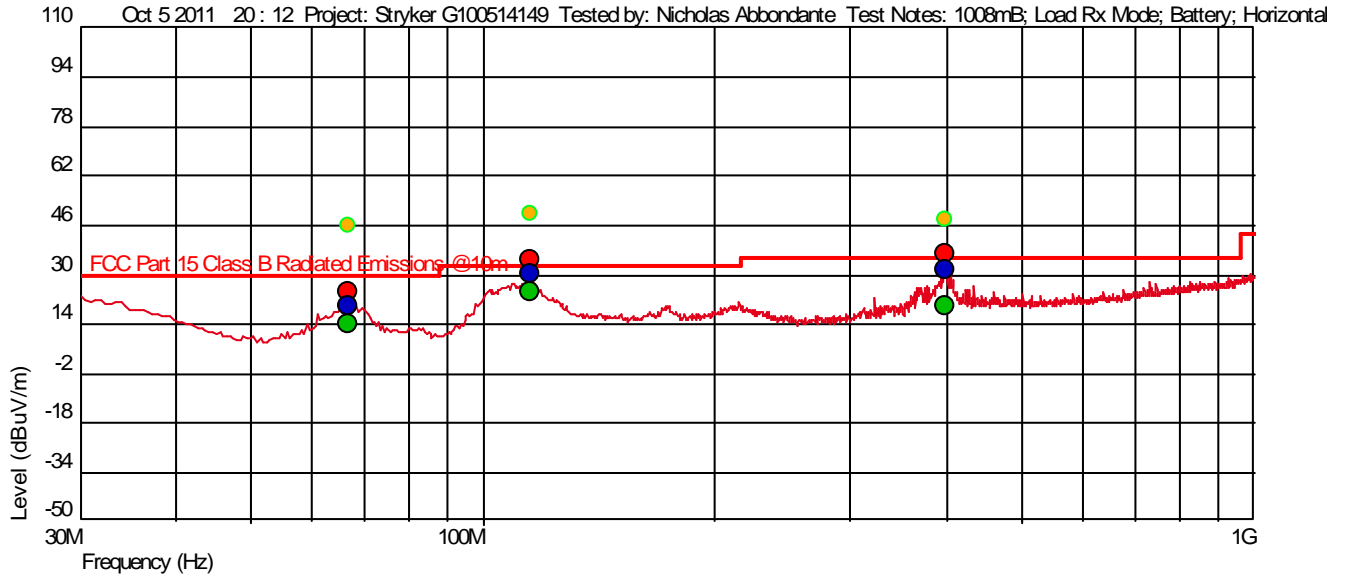

- Measured Peak Value
 - Measured Quasi Peak Value
 - Measured Average Value
 - Maximum Value of Mast and Turntable
- Level (dBuV/m) = AF + CL + PA + Raw
 AF = Antenna Factor
 CL = Cable Losses
 PA = Pre-Amplifier
 Raw = Raw Instrument Reading (Not listed on Spot Tables)

Measured: QP

Frequency (Hz)	Level* (dBuV/m)	AF	PA+CL	Limit (dBuV/m)	Margin (dBuV/m)	Hor (°), Ver (°)	Angle (Deg)	Mast Height (m)	Detector	RBW(Hz)
66.948 M	20.20	8.200	-25.913	29.54	-9.34	--	121	3.99	QP	120 k
115.114 M	30.41	13.500	-25.314	33.04	-2.63	--	304	4.00	QP	120 k
396.537 M	31.61	15.462	-23.848	35.54	-3.93	--	350	2.19	QP	120 k

Test Personnel: Nicholas Abbondante ~~N/A~~
Supervising Engineer: N/A
(Where Applicable)
Product Standard: FCC Part 15 Subpart B 15.109,
Input Voltage: IC RSS-Gen Section 6.0
Pretest Verification w/ 12 VDC Internal Battery
Ambient Signals or
BB Source: Ambient Signals

Test Date: 10/05/2011
Test Levels: See test results
Ambient Temperature: 20 °C
Relative Humidity: 52 %
Atmospheric Pressure: 1008 mbars

Deviations, Additions, or Exclusions: None

10 20 dB Bandwidth

10.1 Method

Tests are performed in accordance with FCC Part 15:2011 Subpart C 15.225, IC RSS-Gen Issue 3 December 2010 Section 4.6, ANSI C63.4-2003.

TEST SITE: AMAP Lab

The EMC Lab has two Semi-anechoic Chambers and one Shielded Chamber. AC Mains Power is available at 120, 230, and 277 Single Phase; 208, 400, and 480 3-Phase. Large reference ground-planes are installed in the general lab area to facilitate EMC work not requiring a shielded environment.

The AMAP Building and Lab includes general lab space that can be used for testing where a shielded/enclosed environment is not required.

10.2 Test Equipment Used:

Asset	Description	Manufacturer	Model	Serial	Cal Date	Cal Due
DAV001'	Weather Station	Davis Instruments	7400	PE80519A61	08/17/2011	08/17/2012
MET4'	Digital Multimeter	Meterman	15XP	050505984	01/28/2011	01/28/2012
146029'	DC Power Supply (0-30 volts 3 amps)	Electro Industries	DIGI 35A	M12/EM 1127-01	VBU	Verified
148013'	Temp/Humidity Chamber	Envirotronics	SH27C	08015563S11264	10/05/2011	10/05/2012
ROS001'	Spectrum Analyzer 20Hz - 40 GHz	Rohde & Schwartz	FSEK-30	100225	01/13/2011	01/13/2012
CBLBNC61'	Coaxial Cable	Pomona	RG58	CBLBNC61	09/08/2011	09/08/2012

Software Utilized:

Name	Manufacturer	Version
None		

10.3 Results:

The sample tested was found compliant. The 20 dB bandwidth remains within the assigned band.

10.4 Setup Photographs:

Test Setup Photo # 1



Test Setup Photo # 2



10.5 Data:

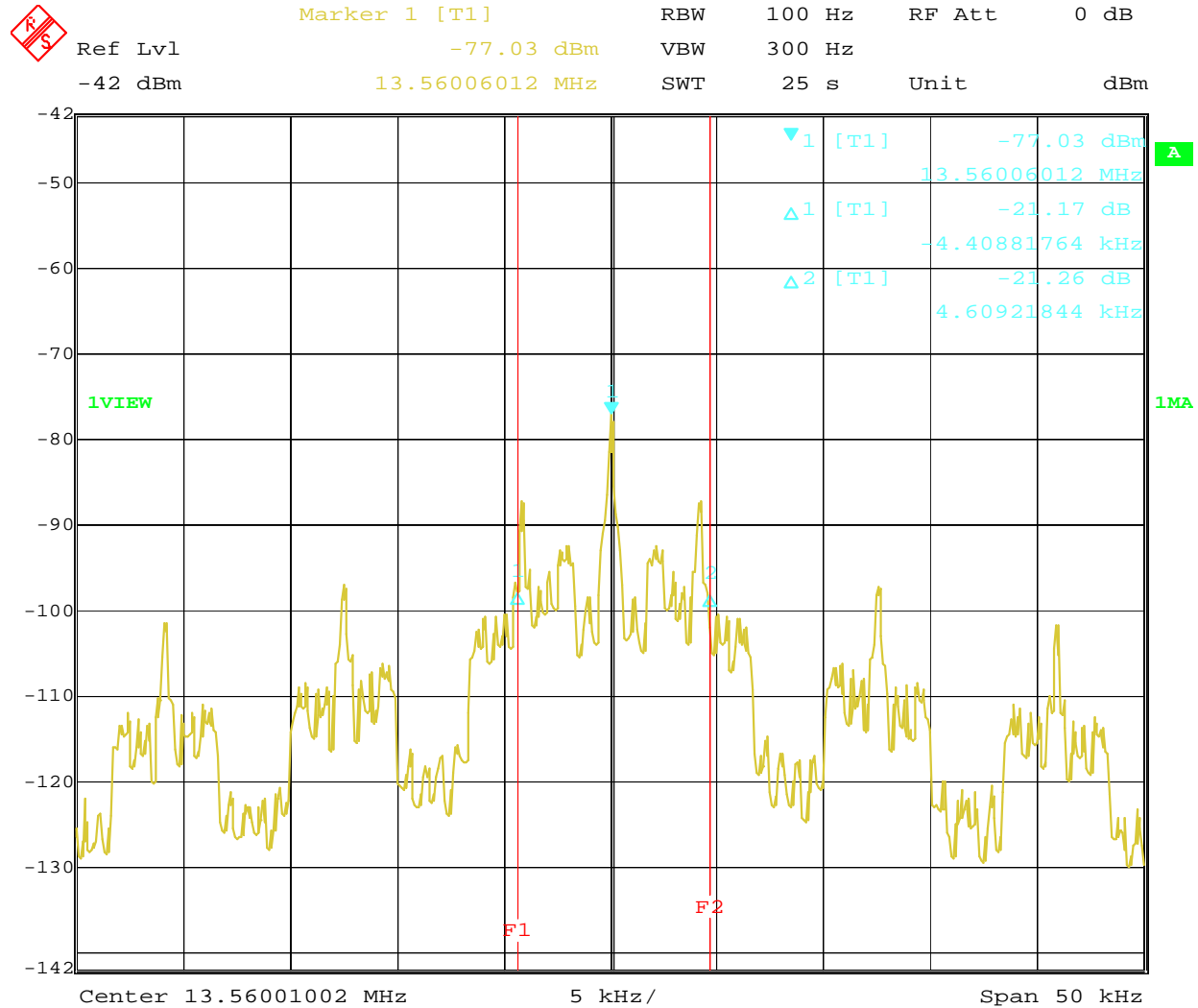

Date: 11.OCT.2011 14:21:23

Test Personnel(s): Kouma Sinn *KPS*
 Supervising Engineer: _____
 (Where Applicable) N/A
 Product Standard: FCC Part 15.225, IC RSS-Gen Section 4.6
 Input Voltage: 9 VDC From Support Power Supply
 Pretest Verification w/
 Ambient Signals or
 BB Source: N/A

Test Date(s): 10/11/2011
 Test Levels: See test results
 Ambient Temperature: 21 °C
 Relative Humidity: 48 %
 Atmospheric Pressure: 1014 mbars

Deviations, Additions, or Exclusions: None

11 Frequency Stability

11.1 Method

Tests are performed in accordance with FCC Part 15:2011 Subpart C 15.225(e), IC RSS-Gen Issue 3 December 2010 Section 4.7, IC RSS-210 December 2010 A2.6, ANSI C63.4-2003.

TEST SITE: AMAP lab

The EMC Lab has two Semi-anechoic Chambers and one Shielded Chamber. AC Mains Power is available at 120, 230, and 277 Single Phase; 208, 400, and 480 3-Phase. Large reference ground-planes are installed in the general lab area to facilitate EMC work not requiring a shielded environment.

The AMAP Building and Lab includes general lab space that can be used for testing where a shielded/enclosed environment is not required.

11.2 Test Equipment Used:

Asset	Description	Manufacturer	Model	Serial	Cal Date	Cal Due
DAV001'	Weather Station	Davis Instruments	7400	PE80519A61	08/17/2011	08/17/2012
MET4'	Digital Multimeter	Meterman	15XP	050505984	01/28/2011	01/28/2012
146029'	DC Power Supply (0-30 volts 3 amps)	Electro Industries	DIGI 35A	M12/EM 1127-01	VBU	Verified
148013'	Temp/Humidity Chamber	Envirotronics	SH27C	08015563S11264	10/05/2011	10/05/2012
ROS001'	Spectrum Analyzer 20Hz - 40 GHz	Rohde & Schwartz	FSEK-30	100225	01/13/2011	01/13/2012
CBLBNC61'	Coaxial Cable	Pomona	RG58	CBLBNC61	09/08/2011	09/08/2012

Software Utilized:

Name	Manufacturer	Version
EMI Boxborough.xls	Intertek	08/27/10

11.3 Results:

The sample tested was found compliant.

The fundamental frequency shall remain within $\pm 0.01\%$ of the operating frequency over a temperature variation of -30 degrees to +50 degrees. Voltage variations of $\pm 15\%$ were also performed.

11.4 Setup Photographs:

Test Setup Photo # 1



Test Setup Photo # 2



11.5 Data:

Frequency Stability

Company: Stryker Medical
 Model #: Power-System LOAD (Comm. Board)
 Serial #: 45305067
 Engineer(s): Kouma Sinn
 Project #: G100514149
 Standard: FCC Part 15 Subpart C Section 15.225 & RSS-210 Annex 2 (A2.6)
 Limit: 100 PPM

Test Equipment Used:
 MET4 146-029 ROS001
 148-013 DAV001 CBLBNC61

Location: AMAP Lab
 Date(s): 10/11/11

Nominal f: 13.56 MHz

Voltage: 9 VDC

%	Voltage Volts	Frequency MHz	Deviation kHz	Limit kHz
-15%	7.65	13.560000	-0.0204	1.36
-10%	8.1	13.560020	-0.00036	1.36
-5%	8.55	13.559980	-0.04044	1.36
+0%	9	13.560020	0	1.36
+5%	9.45	13.560000	-0.0204	1.36
+10%	9.9	13.560020	-0.00036	1.36
+15%	10.35	13.560000	-0.0204	1.36

Temp Celsius	Frequency MHz	Deviation kHz	Limit kHz
-30	13.559940	-0.08016	1.36
-20	13.559980	-0.04008	1.36
-10	13.560020	0	1.36
0	13.560020	0	1.36
10	13.560016	-0.00404	1.36
20	13.560020	0	1.36
30	13.559980	-0.04008	1.36
40	13.559980	-0.04008	1.36
50	13.559980	-0.04008	1.36

Test Personnel(s): Kouma Sinn *KPS*
 Supervising Engineer: _____
 (Where Applicable) N/A
 Product Standard: FCC Part 15.225 and IC RSS-210 A2.6
 Input Voltage: Powered from DC power supply (see table)
 Pretest Verification w/
 Ambient Signals or
 BB Source: N/A

Test Date(s): 10/11/2011
 Test Levels: See test results
 Ambient Temperature: 21 °C
 Relative Humidity: 48 %
 Atmospheric Pressure: 1014 mbars

Deviations, Additions, or Exclusions: None

12 Revision History

Revision Level	Date	Report Number	Notes
0	10/14/2011	100514149BOX-003c	Original Issue