





# FCC Radio Test Report

## FCC ID: YRCOP-D09

**Report No.** : TB-FCC107795  
**Applicant** : SHENZHEN OPIZ ELECTRONICS CO., LTD.  
**Equipment Under Test (EUT)**  
**EUT Name** : Wireless Video Door Phone  
**Model No.** : OP-D03  
**Serial No.** : OP-D0X ("X" is the number from 1 to 9 )  
**Brand Name** : OPIZ  
**Receipt Date** : 2010-09-20  
**Test Date** : 2010-09-20 to 2010-10-18  
**Issue Date** : 2010-10-20  
**Tested By:** : Bontek Compliance Testing Laboratory Ltd.  
**Standards** : FCC Part 15, Subpart C(15.247)/ANSI C63.4:2003  
**Test/Witness Engineer** :   
**Approved & Authorized** : 

---

---

## Contents

<b>CONTENTS.....</b>	<b>2</b>
<b>TEST REPORT DECLARATION .....</b>	<b>4</b>
<b>1. GENERAL INFORMATION ABOUT EUT .....</b>	<b>5</b>
1.1 General Description of EUT (Equipment Under Test) .....	5
1.2 Block Diagram Showing The Configuration of System Tested.....	6
1.3 Description of Support Units .....	6
1.4 Description of Test Mode.....	6
1.5 Test Facility.....	7
<b>2. TEST SUMMARY.....</b>	<b>8</b>
<b>3. CONDUCTED EMISSION TEST .....</b>	<b>9</b>
3.1 Test Standard and Limit.....	9
3.2 Test Setup.....	9
3.3 Test Procedure.....	9
3.4 Test Equipment Used.....	10
3.5 Test Data.....	10
Test.....	11
<b>4. RADIATED EMISSION TEST .....</b>	<b>13</b>
4.1 Test Standard and Limit.....	13
4.2 Test Setup.....	14
4.3 Test Procedure.....	15
4.4 EUT Operating Condition .....	15
4.5 Test Equipment.....	16
4.6 Test Condition .....	16
<b>5. RESTRICTED BANDS REQUIREMENT .....</b>	<b>23</b>
5.1 Test Standard and Limit.....	23
5.2 Test Setup.....	23
5.3 Test Procedure.....	23
5.4 EUT Operating Condition .....	24
5.5 Test Equipment.....	24
<b>6. NUMBER OF HOPPING CHANNEL .....</b>	<b>27</b>
6.1 Test Standard and Limit.....	27
6.2 Test Setup.....	27
6.3 Test Procedure.....	27
6.4 EUT Operating Condition .....	27
6.5 Test Equipment.....	27
<b>7. AVERAGE TIME OF OCCUPANCY.....</b>	<b>29</b>
7.1 Test Standard and Limit.....	29
7.2 Test Setup.....	29
7.3 Test Procedure.....	29

---

7.4 EUT Operating Condition .....	29
7.5 Test Equipment .....	29
<b>8. CHANNEL SEPARATION AND BANDWIDTH TEST .....</b>	<b>31</b>
8.1 Test Standard and Limit.....	31
8.2 Test Setup.....	31
8.3 Test Procedure.....	31
8.4 EUT Operating Condition .....	31
8.5 Test Equipment .....	32
8.6 Test Data.....	32
<b>9. PEAK OUTPUT POWER TEST.....</b>	<b>36</b>
9.1 Test Standard and Limit.....	36
9.2 Test Setup.....	36
9.3 Test Procedure.....	36
9.4 EUT Operating Condition .....	36
9.5 Test Equipment .....	36
9.6 Test Data.....	36
<b>10. ANTENNA CONDUCTED SPURIOUS EMISSION.....</b>	<b>38</b>
10.1 Test Standard and Limit .....	38
10.2 Test Setup.....	38
10.3 Test Procedure.....	38
10.4 EUT Operating Condition .....	39
10.5 Test Equipment.....	39
10.6 Test Data.....	39
<b>11. ANTENNA REQUIREMENT.....</b>	<b>43</b>
11.1 Standard Requirement.....	43
11.2 Antenna Connected Construction .....	43
11.2 Result.....	43

## Test Report Declaration

**Applicant** : SHENZHEN OPIZ ELECTRONICS CO., LTD.  
**Address** : Yuhong Industry Park, Xingye West RD., Shajing,  
Baoan District, Shenzhen China  
**Manufacturer** : SHENZHEN OPIZ ELECTRONICS CO., LTD.  
**Address** : Yuhong Industry Park, Xingye West RD., Shajing,  
Baoan District, Shenzhen China  
**EUT Description** : Wireless Video Door Phone  
**Model No.** : OP-D03

The device described above is tested by Bontek Compliance Testing Laboratory Ltd. to determine the maximum emission levels emanating from the device. The maximum emission levels are compared to the FCC Part 15 Subpart C limits for both radiation and conduction emissions.

The measurement results are contained in this test report and Shenzhen Toby Technology Co., Ltd. is assumed full responsibility for the accuracy and completeness of these measurements. Also, this report shows that the EUT to be technically compliant with the FCC official limits.

This report applies to above tested sample only. This report shall not be reproduced in part without written approval of Shenzhen Toby Technology Co., Ltd.

# 1. General Information About EUT

## 1.1 General Description of EUT (Equipment Under Test)

<b>EUT Name</b>	:	Wireless Video Door Phone	
<b>Model No.</b>	:	OP-D03, OP-D0X(X=1-9)	
<b>Model difference</b>	:	All above models are identical in schematic, structure and critical components except for different model number and appearance; We choose OP-D03 for test.	
<b>Product Description</b>	:	Operation Frequency: 2410MHz~2470MHz	
		Number of Channel:	61Channels <b>see note (2)</b>
		Out Power	20mW (max)
		Antenna Gain:	2.5 dBi
		Modulation Type:	FHSS
		Date Rate:	GFSK
<b>Power Supply</b>	:	Indoor Minitor: DC Voltage supplied from Adapter/Li-ion Battery	
<b>Power Rating</b>	:	Adapter:I/P: AC 100~240V, 50/60Hz 0.5A Max O/P: DC 12V 1A	
<b>Connecting I/O Port(S)</b>	:	Please refer to the User's Manual	

**Note:**

(1) For a more detailed features description, please refer to the manufacturer's specifications or the User's Manual.

(2) Channel List:

Channel	Frequency (MHz)	Channel	Frequency (MHz)	Channel	Frequency (MHz)
00	2410	21	2431	42	2452
01	2411	22	2432	43	2453
02	2412	23	2433	44	2454
03	2413	24	2434	45	2455
04	2414	25	2435	46	2456
05	2415	26	2436	47	2457
06	2416	27	2437	48	2458
07	2417	28	2438	49	2459
08	2418	29	2439	50	2460

09	2419	30	2440	51	2461
10	2420	31	2441	52	2462
11	2421	32	2442	53	2463
12	2422	33	2443	54	2464
13	2423	34	2444	55	2465
14	2424	35	2445	56	2466
15	2425	36	2446	57	2467
16	2426	37	2447	58	2468
17	2427	38	2448	59	2469
18	2428	39	2449	60	2470
19	2429	40	2450		
20	2430	41	2451		

### 1.2 Block Diagram Showing The Configuration of System Tested

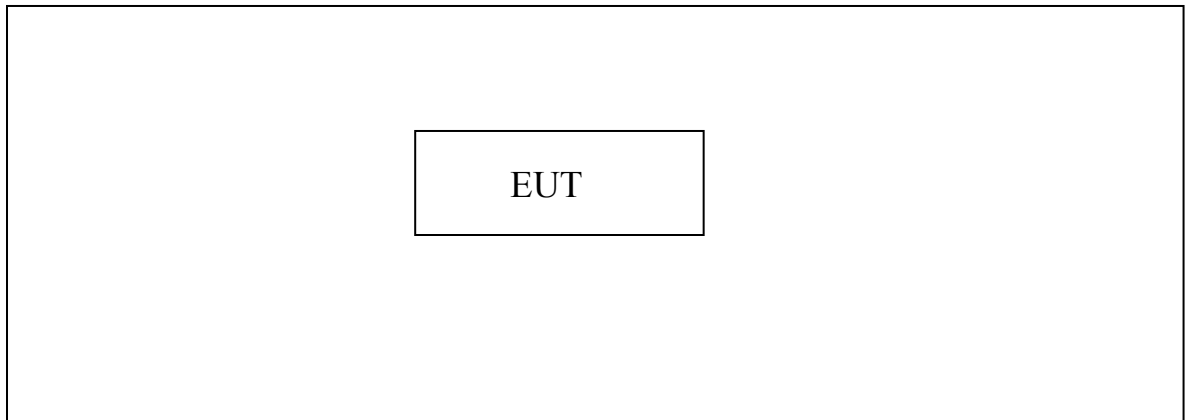

### 1.3 Description of Support Units

Name	Model	S/N	Manufacturer	Used "√"

### 1.4 Description of Test Mode

To investigate the maximum EMI emission characteristics generates from EUT, the test system was pre-scanning tested base on the consideration of following EUT operation mode or test configuration mode which possible have effect on EMI emission level. Each of these EUT operation mode(s) or test configuration mode(s) mentioned follow was evaluated respectively.

For Conducted Test	
Final Test Mode	Description
Mode 1	Normal Link

For Radiated Test	
Final Test Mode	Description
Mode 2	TX Mode Channel 00/30/60

**Note:**

- (1) The measurements are performed at the highest , middle, lowest available channels.
- (2) During the testing procedure, the continuously transmitting mode was programmed by the customer.

### 1.5 Test Facility

The testing report were performed by the Shenzhen Toby Technology Co., Ltd., in their facilities located at 10/F., A Block, Jiada R & D Bldg., No.5 Songpingshan Road, Science & Technology Park, Nanshan District, Shenzhen, China. At the time of testing, the following bodies accredited the Laboratory:

The Laboratory is listed in the United States of American Federal Communications Commission (FCC), and the registration number is 811562.

Jun. 04, 2010 certificated by TUV Rheinland, Shenzhen (Audit Report:17015407-001). The certificate is valid until the next scheduled inspection or up to 18 months, at the discretion of TUV Rhineland.

## 2. Test Summary

FCC Part 15 Subpart 15.247)			
Standard Section	Test Item	Judgment	Remark
15.203	Antenna Requirement	PASS	
15.207	Conducted Emission	PASS	
15.205	Restricted Bands	PASS	
15.247(a)(1)	Hopping Channel Separation	PASS	
15.247(a)(1)	Dwell Time	PASS	
15.247(b)(1)	Peak Output Power	PASS	
15.247(b)(1)	Number of Hopping Frequency	PASS	
15.247(c)	Radiated Spurious Emission	PASS	
15.247(c)	Antenna Conducted Spurious Emission	PASS	
<b>Note:</b> N/A is an abbreviation for Not Applicable.			



### 3. Conducted Emission Test

#### 3.1 Test Standard and Limit

3.1.1 Test Standard  
FCC Part 15.207

3.1.2 Test Limit

**Conducted Emission Test Limit**

Frequency	Maximum RF Line Voltage (dB $\mu$ V)	
	Quasi-peak Level	Average Level
150kHz~500kHz	66 ~ 56 *	56 ~ 46 *
500kHz~5MHz	56	46
5MHz~30MHz	60	50

Notes:

- (1) \*Decreasing linearly with logarithm of the frequency.
- (2) The lower limit shall apply at the transition frequencies.
- (3) The limit decrease in line with the logarithm of the frequency in the range of 0.15 to 0.50MHz.

#### 3.2 Test Setup

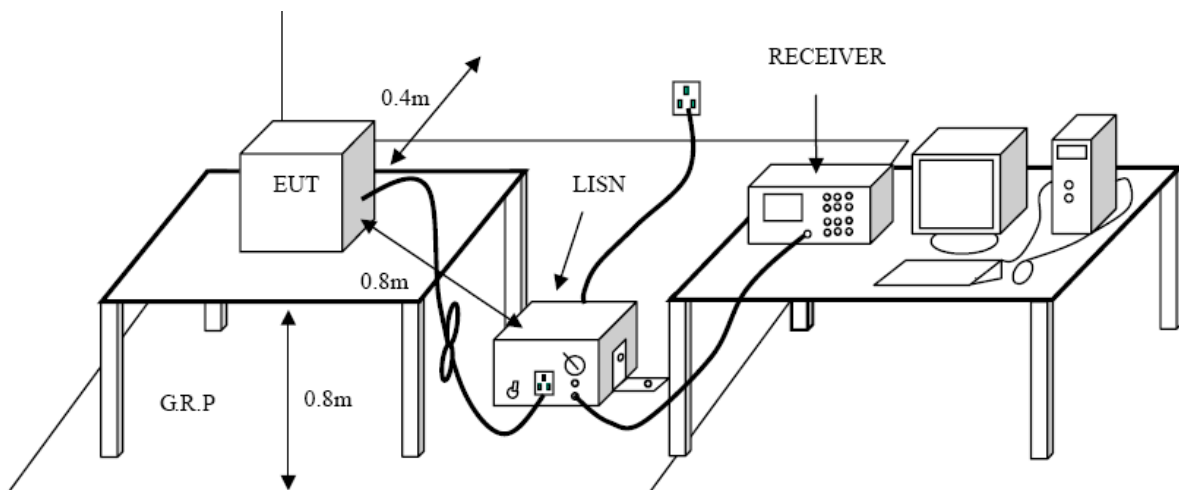

#### 3.3 Test Procedure

The EUT was placed 0.8 meters from the horizontal ground plane with EUT being connected to the power mains through a line impedance stabilization network (LISN). All other support equipments powered from additional LISN(s). The LISN provide 50 Ohm/ 50uH of coupling impedance for the measuring instrument.

Interconnecting cables that hang closer than 40 cm to the ground plane shall be folded back and forth in the center forming a bundle 30 to 40 cm long.

I/O cables that are not connected to a peripheral shall be bundled in the center. The end of the cable may be terminated, if required, using the correct terminating impedance. The overall length shall not exceed 1 m.

LISN at least 80 cm from nearest part of EUT chassis.

The bandwidth of EMI test receiver is set at 9kHz, and the test frequency band is from 0.15MHz to 30MHz.

### 3.4 Test Equipment Used

<b>Description</b>	<b>Manufacturer</b>	<b>Model No.</b>	<b>Serial No.</b>	<b>Cal. Date</b>	<b>Cal. Date</b>
EMI Test Receiver	ROHDE & SCHWARZ	ESC30	DE25181	2010-08-11	2011-08-11
50Ω Coaxial Switch	Anritsu	MP59B	X10321	2010-08-11	2011-08-11
L.I.S.N	EMCO	3624/1	00063417	2010-08-11	2011-08-11
L.I.S.N	EMCO	3624/1	00063417	2010-08-11	2011-08-11

### 3.5 Test Data

Please see the next page.

E.U.T :	Wireless Video Door Phone	Model Name :	OP-D03
Temperature :	23°C	Relative Humidity :	51 %
Terminal	Line		
Test Voltage :	AC 120 V / 60Hz		
Test Mode :	Normal MODE		

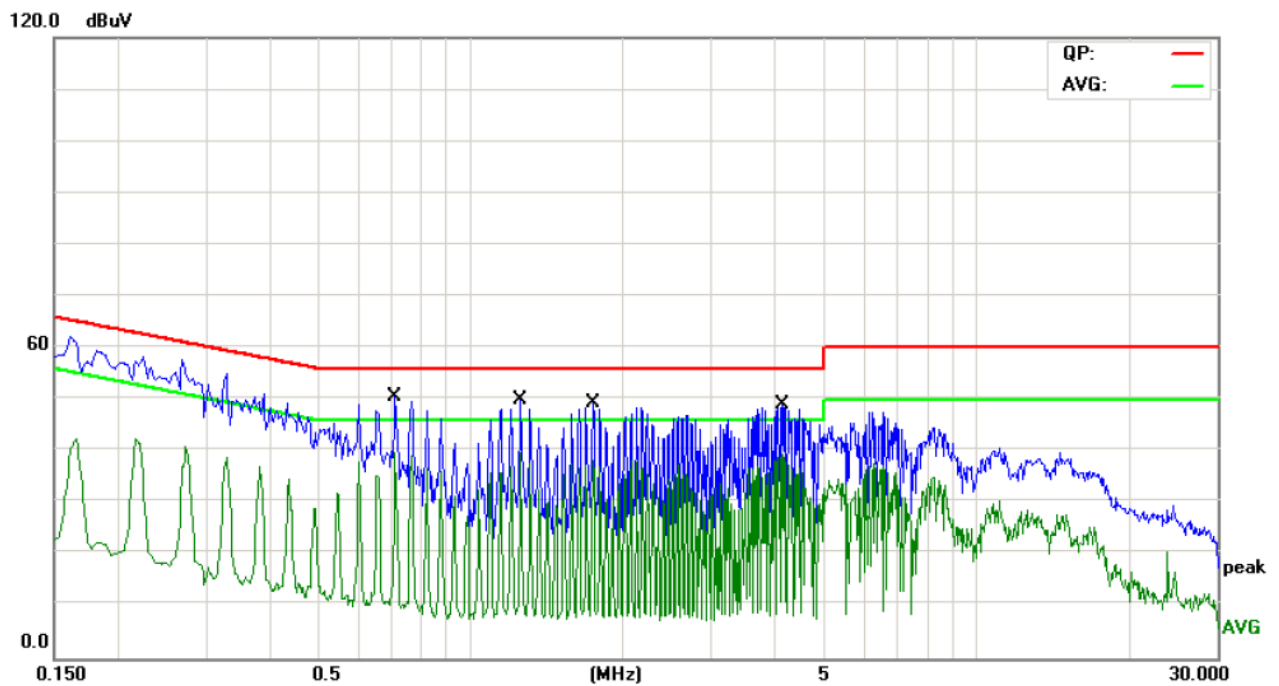

No.	Mk.	Freq.	Reading Level	Correct Factor	Measurement	Limit	Over	Detector	Comment
		MHz	dBuV	dB	dBuV	dBuV	dB		
1	*	0.7100	37.14	11.12	48.26	56.00	-7.74	QP	
2		0.7100	25.97	11.12	37.09	46.00	-8.91	AVG	
3		1.2579	35.82	11.04	46.86	56.00	-9.14	QP	
4		1.2579	25.84	11.04	36.88	46.00	-9.12	AVG	
5		1.7500	35.54	10.97	46.51	56.00	-9.49	QP	
6		1.7500	24.79	10.97	35.76	46.00	-10.24	AVG	
7		4.1540	35.25	10.62	45.87	56.00	-10.13	QP	
8		4.1540	26.38	10.62	37.00	46.00	-9.00	AVG	

E.U.T :	Wireless Video Door Phone	Model Name :	OP-D03
Temperature :	23°C	Relative Humidity :	51 %
Terminal	Neutral		
Test Voltage :	AC 120 V / 60Hz		
Test Mode :	Normal MODE		

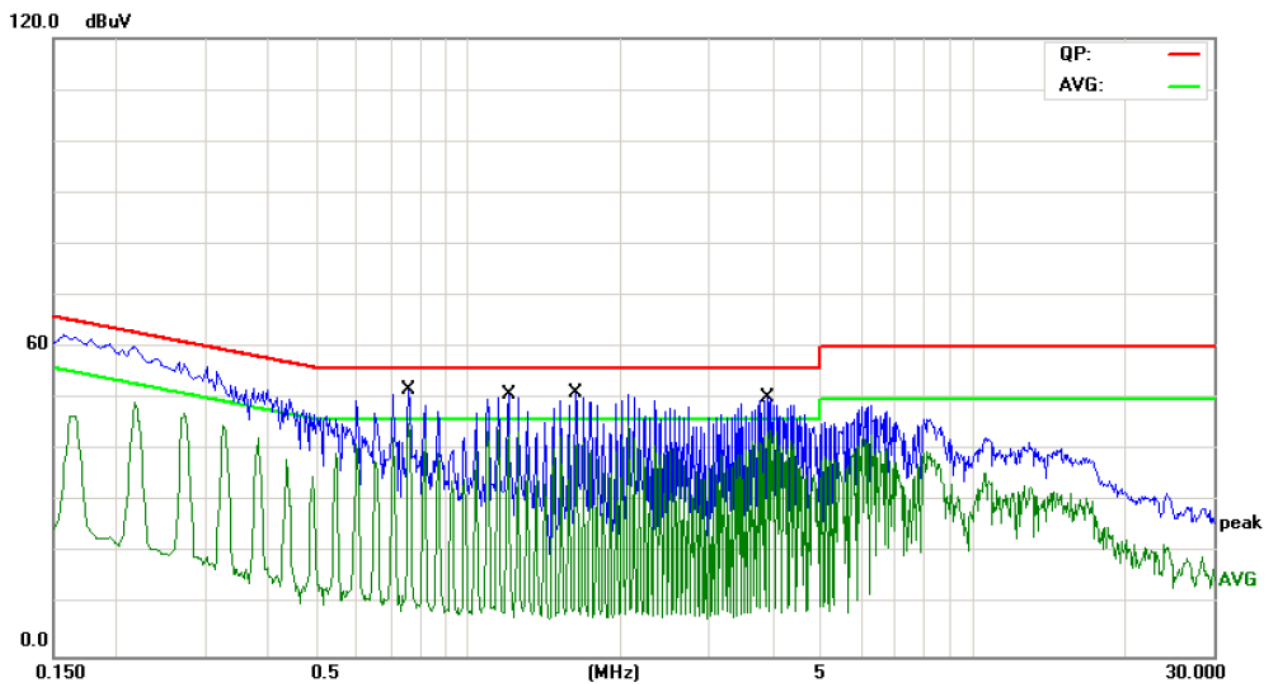

No.	Mk.	Freq.	Reading Level	Correct Factor	Measurement	Limit	Over	Detector	Comment
		MHz	dBuV	dB	dBuV	dBuV	dB		
1		0.7580	34.21	11.11	45.32	56.00	-10.68	QP	
2		0.7580	27.63	11.11	38.74	46.00	-7.26	AVG	
3		1.1980	38.73	11.05	49.78	56.00	-6.22	QP	
4		1.1980	32.25	11.05	43.30	46.00	-2.70	AVG	
5		1.6340	39.03	11.00	50.03	56.00	-5.97	QP	
6	*	1.6340	32.53	11.00	43.53	46.00	-2.47	AVG	
7		3.9220	37.93	10.64	48.57	56.00	-7.43	QP	
8		3.9220	30.62	10.64	41.26	46.00	-4.74	AVG	

## 4. Radiated Emission Test

### 4.1 Test Standard and Limit

#### 4.1.1 Test Standard

FCC Part 15.209

#### 4.1.2 Test Limit

**Radiated Emission Limit(9kHz~1000MHz)**

Frequency (MHz)	Field Strength (microvolt/meter)	Measurement Distance (meters)
0.009~0.490	2400/F(KHz)	300
0.490~1.705	24000/F(KHz)	30
1.705~30.0	30	30
30~88	100	3
88~216	150	3
216~960	200	3
Above 960	500	3

**Radiated Emission Limit (Above 1000MHz)**

Frequency (MHz)	Class A (dBuV/m)(at 3 M)		Class B (dBuV/m)(at 3 M)	
	Peak	Average	Peak	Average
Above 1000	80	60	74	54

Note:

- (1) The tighter limit applies at the band edges.
- (2) Emission Level(dBuV/m)=20log Emission Level(Uv/m)

4.2 Test Setup

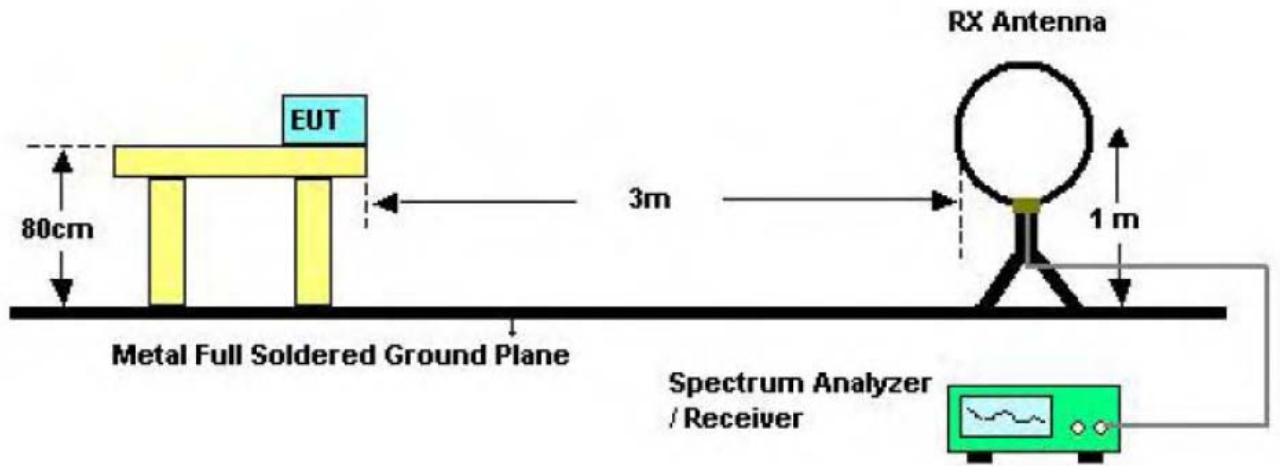

Bellow 30MHz Test Setup

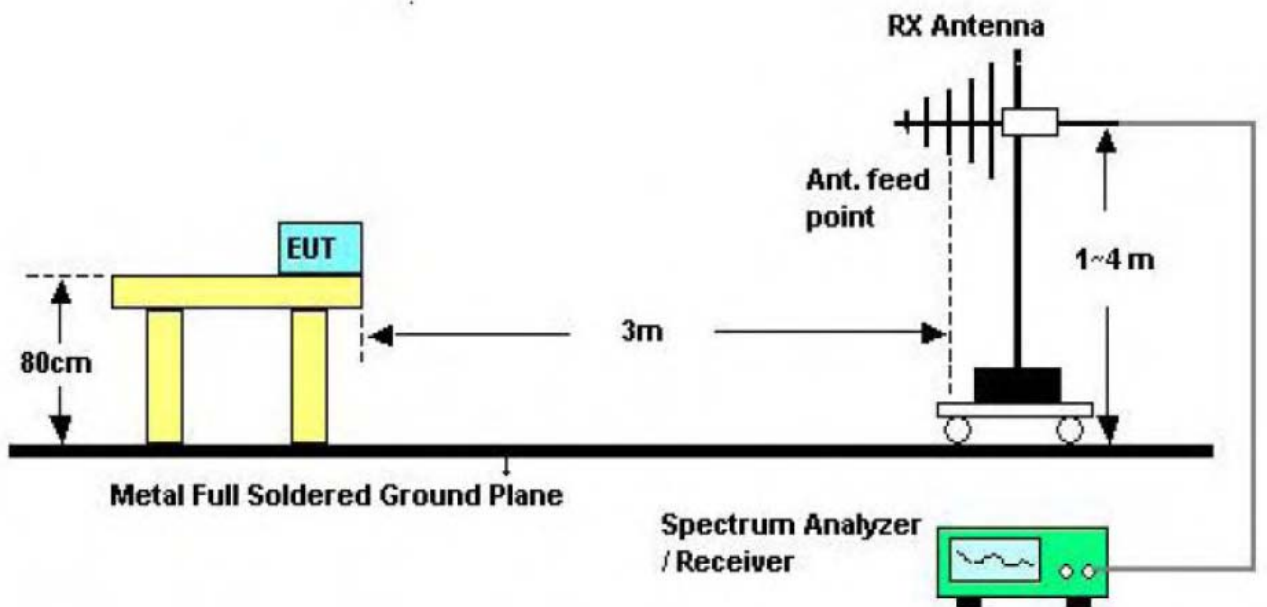

Bellow 1000MHz Test Setup

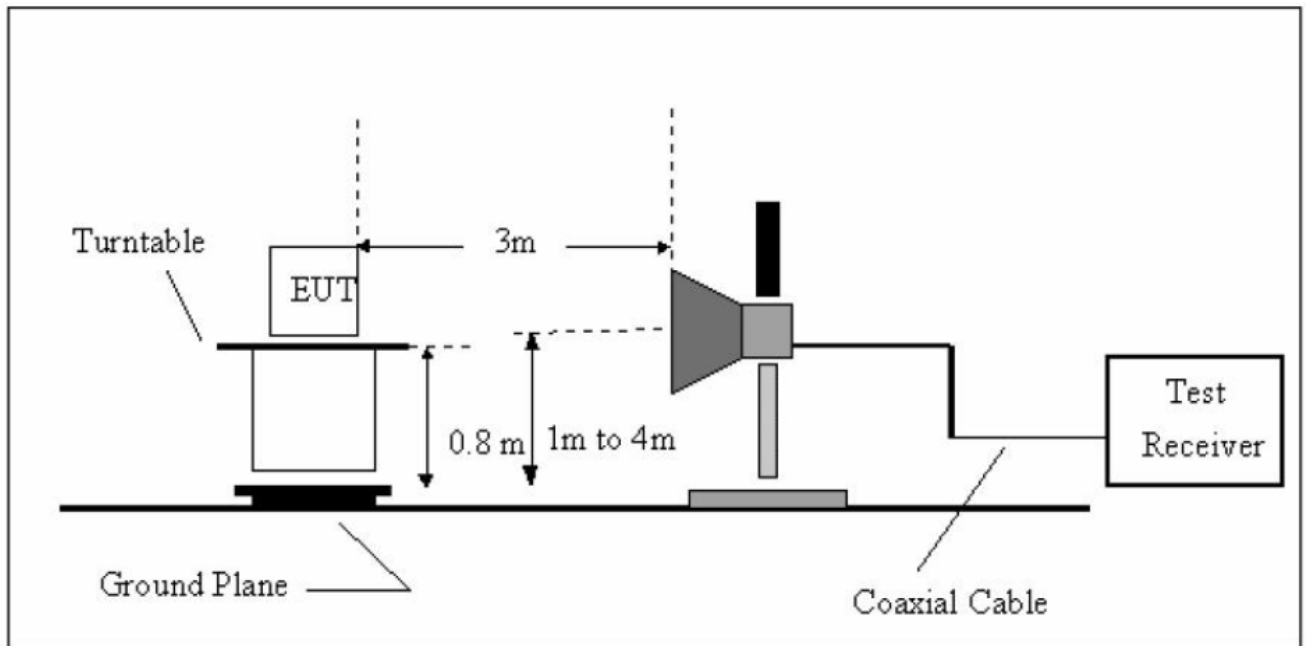

Above 1GHz Test Setup

#### 4.3 Test Procedure

- (1) The measuring distance of 3m shall be used for measurements at frequency up to 1GHz and above 1 GHz. The EUT was placed on a rotating 0.8m high above ground, the table was rotated 360 degrees to determine the position of the highest radiation.
- (2) The Test antenna shall vary between 1m and 4m, Both Horizontal and Vertical antenna are set to make measurement.
- (3) The initial step in collecting conducted emission data is a spectrum analyzer peak detector mode pre-scanning the measurement frequency range. Significant peaks are then marked and then Quasi Peak detector mode re-measured.
- (4) If the Peak Mode measured value compliance with and lower than Quasi Peak Mode Limit Bellow 1 GHz, the EUT shall be deemed to meet QP Limits and then no additional QP Mode measurement performed. But the Peak Value and average value both need to comply with applicable limit above 1 GHz.
- (5) For the actual test configuration, please see the test setup photo.

#### 4.4 EUT Operating Condition

The Equipment Under Test was set to Continual Transmitting in maximum power.

#### 4.5 Test Equipment

Description	Manufacturer	Model No.	Serial No.	Cal. Date	Cal. Date
Spectrum Analyzer	ROHDE& SCHWARZ	FSEA20	DE25181	2010-08-12	2011-08-11
Positioning Controller	C&C	CC-C-1F	N/A	2010-08-12	2011-08-11
Trilog Broadband Antenna	SCHWARZBEC K	VULB9163	9163-333	2010-07-21	2011-07-20
Horn Antenna	SCHWARZBEC K	BBHX 9120	9120-426	2010-07-21	2011-07-20
RF Switch	EM	EMSW18	SW060023	2010-08-12	2011-08-11
Amplifier	Agilent	8447F	3113A06717	2010-08-12	2011-08-11
Coaxial Cable	SCHWARZBEC K	AK9513	9513-10	2010-08-12	2011-08-11
EMI Test Receiver	ROHDE& SCHWARZ	ESPI	25498514	2010-08-12	2011-08-11
EMI Test Receiver	ROHDE& SCHWARZ	ESI26	838786/103	2010-08-12	2011-08-11
Receiver Horn Antenna	ROHDE& SCHWARZ	HF906	100013	2010-08-12	2011-08-11

#### 4.6 Test Condition

Temperature	:	25 °C
Relative Humidity	:	48 %
Pressure	:	1010 hPa
Test Power	:	AC 120V/60Hz



## 4.7 Test Data

Operation Mode: 2410MHz                      Test Date : October 10, 2010  
 Frequency Range: 30~1000MHz              Temperature : 28 °C  
 Measured Distance: 3m                      Humidity : 65 %

Freq. (MHz)	Ant.Pol. H/V	Emission Level (dBuV)	Limit 3m (dBuV/m)	Margin (dB)	Note
97.69	V	37.60	43.50	5.9	PK
185.60	V	37.42	43.50	6.08	PK
206.85	V	34.06	43.50	9.44	PK
482.17	V	40.83	46.00	5.17	PK
507.20	V	36.52	46.00	9.48	PK
689.52	V	41.34	46.00	4.66	PK
98.34	H	37.80	43.50	5.7	PK
176.56	H	34.17	43.50	9.33	PK
232.88	H	35.20	46.00	10.8	PK
480.52	H	37.86	46.00	8.14	PK
689.56	H	39.27	46.00	6.73	PK
726.30	H	38.30	46.00	7.7	PK

- Note:**
- (1) All Readings are Peak Value.
  - (2) Emission Level= Reading Level+Probe Factor +Cable Loss
  - (3) The average measurement was not performed when the peak measured data under the limit of average detection.

Operation Mode:	2440MHz	Test Date :	October 10, 2010
Frequency Range:	30~1000MHz	Temperature :	28 °C
Measured Distance:	3m	Humidity :	65 %

Freq. (MHz)	Ant.Pol. H/V	Emission Level (dBuV)	Limit 3m (dBuV/m)	Margin (dB)	Note
98.52	V	35.62	43.50	7.88	PK
169.50	V	37.18	43.50	6.32	PK
206.83	V	37.62	43.50	5.88	PK
516.37	V	41.50	46.00	4.5	PK
689.47	V	40.33	46.00	5.67	PK
835.06	V	41.97	46.00	4.03	PK
106.79	H	36.57	43.50	6.93	PK
167.40	H	38.21	43.50	5.29	PK
212.81	H	36.56	43.50	6.94	PK
527.59	H	36.90	46.00	9.1	PK
688.95	H	39.88	46.00	6.12	PK
835.06	H	41.26	46.00	4.74	PK

- Note:**
- (1) All Readings are Peak Value.
  - (2) Emission Level= Reading Level+Probe Factor +Cable Loss
  - (3) The average measurement was not performed when the peak measured data under the limit of average detection.

---

Operation Mode: 2470MHz                      Test Date : October 10, 2010  
Frequency Range: 30~1000MHz              Temperature : 28 °C  
Measured Distance: 3m                      Humidity : 65 %

Freq. (MHz)	Ant.Pol. H/V	Emission Level (dBuV)	Limit 3m (dBuV/m)	Margin (dB)	Note
106.54	V	37.52	43.50	5.98	PK
216.87	V	34.68	46.00	11.32	PK
285.24	V	34.23	46.00	11.77	PK
408.35	V	37.10	46.00	8.9	PK
689.30	V	39.15	46.00	6.85	PK
738.12	V	40.22	46.00	5.78	PK
98.64	H	35.59	43.50	7.91	PK
186.16	H	36.27	43.50	7.23	PK
285.24	H	34.16	46.00	11.84	PK
408.35	H	38.16	46.00	7.84	PK
480.80	H	37.43	46.00	8.57	PK
738.10	H	41.61	46.00	4.39	PK

- Note:** (1) All Readings are Peak Value.  
(2) Emission Level= Reading Level+Probe Factor +Cable Loss  
(3) The average measurement was not performed when the peak measured data under the limit of average detection.

Operation Mode:	2410MHz	Test Date :	October 10, 2010
Frequency Range:	1-25GHz	Temperature :	28 °C
Measured Distance:	3m	Humidity :	65 %

Freq. (MHz)	Ant.Pol. H/V	Emission Level(dBuV)		Limit 3m(dBuV/m)		Margin(dB)	
		PK	AV	PK	AV	PK	AV
1521.50	V	56.47	44.86	74.00	54.00	17.53	9.14
4820.60	V	61.61	50.73	74.00	54.00	12.39	3.27
7230.90	V	54.07	42.58	74.00	54.00	19.93	11.42
--	V	--	--	74.00	54.00	--	--
--	V	--	--	74.00	54.00	--	--
1521.50	H	55.32	45.01	74.00	54.00	18.68	8.99
4820.60	H	61.45	49.68	74.00	54.00	12.55	4.32
7230.90	H	53.87	42.50	74.00	54.00	20.13	11.5
--	H	--	--	74.00	54.00	--	--
--	H	--	--	74.00	54.00	--	--

**Other harmonics emissions are lower than 20dB below the allowable limit.**

- Note:**
- (1) All Readings are Peak Value and AV.
  - (2) Emission Level= Reading Level + Probe Factor +Cable Loss
  - (3) Data of measurement within this frequency range shown “ -- ” in the table above means the reading of emissions are attenuated more than 20dB below the permissible limits or the field strength is too small to be measured.

Operation Mode:	2440MHz	Test Date :	October 10, 2010
Frequency Range:	1-25GHz	Temperature :	28 °C
Measured Distance:	3m	Humidity :	65 %

Freq. (MHz)	Ant.Pol. H/V	Emission Level(dBuV)		Limit 3m(dBuV/m)		Margin(dB)	
		PK	AV	PK	AV	PK	AV
1520.60	V	58.77	47.56	74.00	54.00	15.23	6.44
4880.50	V	60.08	48.73	74.00	54.00	13.92	5.27
7320.90	V	54.60	43.28	74.00	54.00	19.4	10.72
--	V	--	--	74.00	54.00	--	--
--	V	--	--	74.00	54.00	--	--
1520.60	H	57.86	45.79	74.00	54.00	16.14	8.21
4880.50	H	60.35	48.63	74.00	54.00	13.65	5.37
7320.90	H	53.21	42.12	74.00	54.00	20.79	11.88
--	H	--	--	74.00	54.00	--	--
--	H	--	--	74.00	54.00	--	--

**Other harmonics emissions are lower than 20dB below the allowable limit.**

- Note:**
- (1) All Readings are Peak Value and AV.
  - (2) Emission Level= Reading Level + Probe Factor +Cable Loss
  - (3) Data of measurement within this frequency range shown “ -- ” in the table above means the reading of emissions are attenuated more than 20dB below the permissible limits or the field strength is too small to be measured.

Operation Mode:	2470MHz	Test Date :	October 10, 2010
Frequency Range:	1-25GHz	Temperature :	28 °C
Measured Distance:	3m	Humidity :	65 %

Freq. (MHz)	Ant.Pol. H/V	Emission Level(dBuV)		Limit 3m(dBuV/m)		Margin(dB)	
		PK	AV	PK	AV	PK	AV
1592.50	V	54.13	45.18	74.00	54.00	19.87	8.82
4940.20	V	59.68	48.95	74.00	54.00	14.32	5.05
7320.60	V	53.86	43.20	74.00	54.00	20.14	10.8
--	V	--	--	74.00	54.00	--	--
--	V	--	--	74.00	54.00	--	--
1592.50	H	55.30	45.50	74.00	54.00	18.7	8.5
4940.20	H	58.76	49.13	74.00	54.00	15.24	4.87
7320.60	H	53.27	42.79	74.00	54.00	20.73	11.21
--	H	--	--	74.00	54.00	--	--
--	H	--	--	74.00	54.00	--	--

**Other harmonics emissions are lower than 20dB below the allowable limit.**

- Note:**
- (1) All Readings are Peak Value and AV.
  - (2) Emission Level= Reading Level + Probe Factor +Cable Loss
  - (3) Data of measurement within this frequency range shown “ -- ” in the table above means the reading of emissions are attenuated more than 20dB below the permissible limits or the field strength is too small to be measured.

## 5. Restricted Bands Requirement

### 5.1 Test Standard and Limit

#### 5.1.1 Test Standard

FCC Part 15.209

FCC Part 15.205

#### 5.1.2 Test Limit

Restricted Frequency Band (MHz)	Class B (dBuV/m)(at 3 M)	
	Peak	Average
2310 ~2390	74	54
2483.5 ~2500	74	54

### 5.2 Test Setup

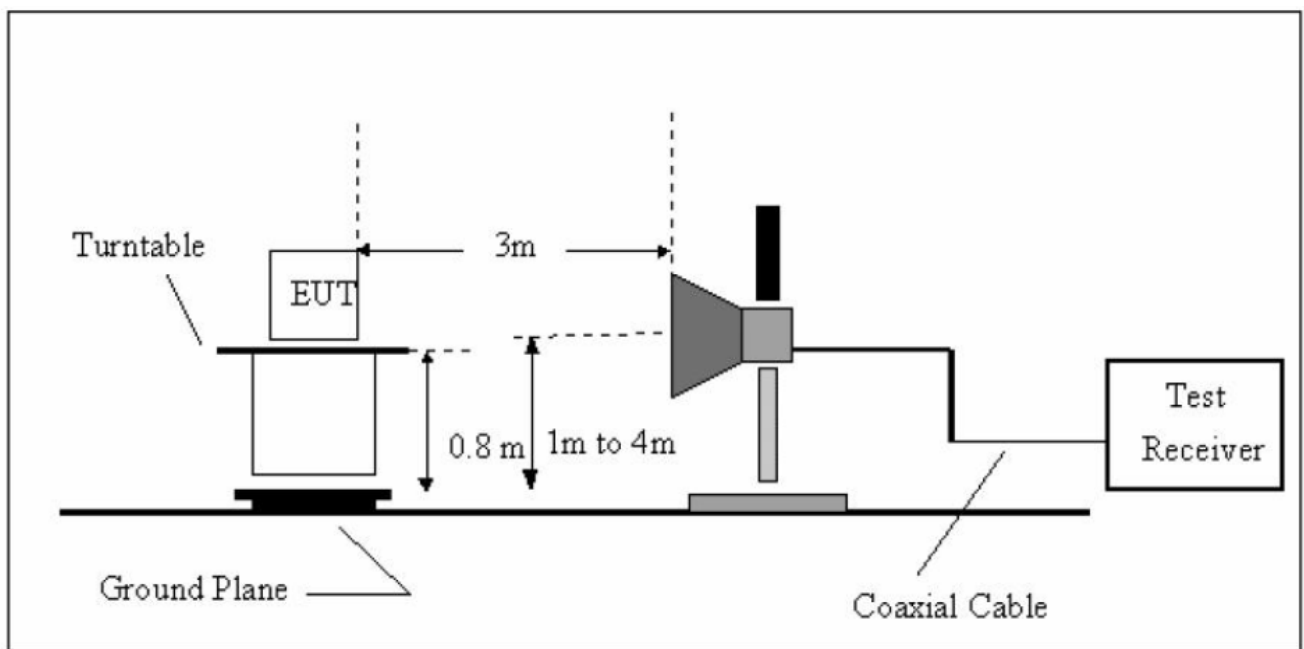

### 5.3 Test Procedure

- (1) The measuring distance of 3m shall be used for measurements at frequency up to 1GHz and above 1 GHz. The EUT was placed on a rotating 0.8m high above ground, the table was rotated 360 degrees to determine the position of the highest radiation.
- (2) The Test antenna shall vary between 1m and 4m, Both Horizontal and Vertical antenna are set to make measurement.
- (3) The initial step in collecting conducted emission data is a spectrum analyzer peak detector mode pre-scanning the measurement frequency range. Significant peaks are then marked and then Quasi Peak detector mode re-measured.

- (4) If the Peak Mode measured value compliance with and lower than Quasi Peak Mode Limit Bellow 1 GHz, the EUT shall be deemed to meet QP Limits and then no additional QP Mode measurement performed. But the Peak Value and average value both need to comply with applicable limit above 1 GHz.
- (5) For the actual test configuration, please see the test setup photo.

#### 5.4 EUT Operating Condition

The Equipment Under Test was set to Continual Transmitting in maximum power.

#### 5.5 Test Equipment

Description	Manufacturer	Model No.	Serial No.	Cal. Date	Cal. Date
Spectrum Analyzer	ROHDE& SCHWARZ	FSEA20	DE25181	2010-08-12	2011-08-11
Positioning Controller	C&C	CC-C-1F	N/A	2010-08-12	2011-08-11
Trilog Broadband Antenna	SCHWARZBEC K	VULB9163	9163-333	2010-07-21	2011-07-20
Horn Antenna	SCHWARZBEC K	BBHX 9120	9120-426	2010-07-21	2011-07-20
RF Switch	EM	EMSW18	SW060023	2010-08-12	2011-08-11
Amplifier	Agilent	8447F	3113A06717	2010-08-12	2011-08-11
Coaxial Cable	SCHWARZBEC K	AK9513	9513-10	2010-08-12	2011-08-11
EMI Test Receiver	ROHDE& SCHWARZ	ESPI	25498514	2010-08-12	2011-08-11
EMI Test Receiver	ROHDE& SCHWARZ	ESI26	838786/103	2010-08-12	2011-08-11
Receiver Horn Antenna	ROHDE& SCHWARZ	HF906	100013	2010-08-12	2011-08-11



## 5.6 Test Data

Spectrum Detector: PK                      Test Date : September 26, 2010  
 Temperature : 28 °C                      Humidity : 65 %

### 1. Conducted Test

Frequency (MHz)	Peak Power Output(dBm)	Emission read Value(dBm)	Result of Band edge(dBc)	Band edge Limit(dBc)
<2400	1.98	-50.03	52.01	>20dBc
>2483.5	0.99	-54.51	55.30	>20dBc

### 2. Radiated emission test

Frequency (MHz)	Antenna polarization (H/V)	Emission (dBuV/m)		Band edge Limit (dBuV/m)	
		QP	AV	QP	AV
<2400	V	60.64	49.58	74.00	54.00
>2483.5	V	56.37	46.03	74.00	54.00



Ref 10 dBm \*Att 30 dB \*RBW 100 kHz Marker 1 [T1] 1.98 dBm  
\*VBW 100 kHz 2.409787500 GHz  
\*SWT 35 ms

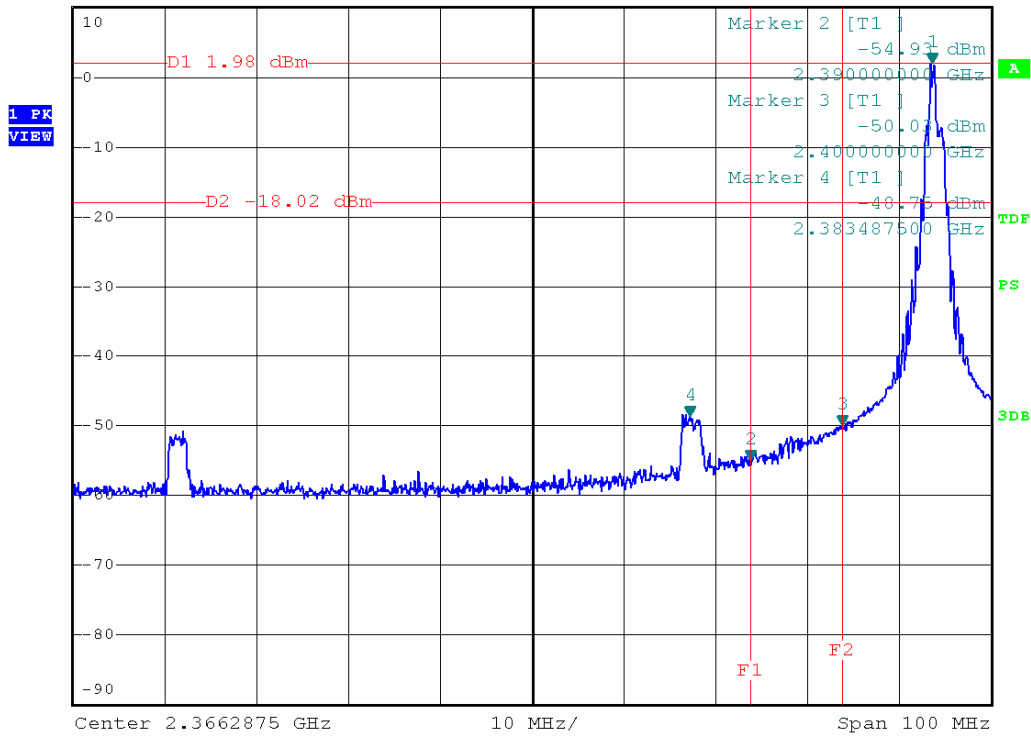

Ref 10 dBm \*Att 30 dB \*RBW 100 kHz Marker 4 [T1] -55.30 dBm  
\*VBW 100 kHz 2.492600000 GHz  
\*SWT 35 ms

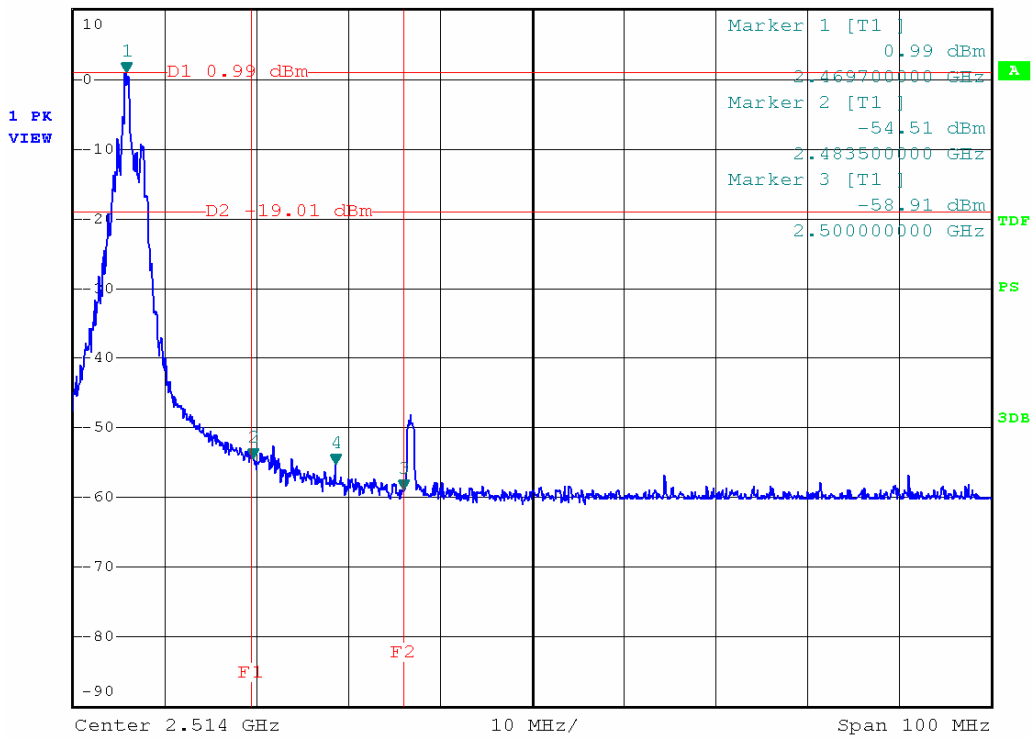

## 6. Number of Hopping Channel

### 6.1 Test Standard and Limit

#### 5.1.1 Test Standard

FCC Part 15.247 (a)(1)

#### 5.1.2 Test Limit

FCC Part 15 Subpart C(15.247)		
Section	Test Item	Limit
15.247	Number of Hopping Channel	>15

### 6.2 Test Setup



### 6.3 Test Procedure

- (1) The EUT was directly connected to the spectrum analyzer and antenna output port as show in the block diagram above.
- (2) Spectrum Setting:RBW=100 KHz, VBW=100 KHz, Sweep time= Auto.

### 6.4 EUT Operating Condition

The EUT was set to the Hopping Mode by the Customer.

### 6.5 Test Equipment

Description	Manufacturer	Model No.	Serial No.	Cal. Date	Cal. Date
Spectrum Analyzer	ROHDE& SCHWARZ	FSEA20	DE25181	2010-08-12	2011-08-11

### 6.6 Test Data

Hopping Channel Frequency Range	Quantity of Hopping Channel	Limit
2410-2470	61	>15

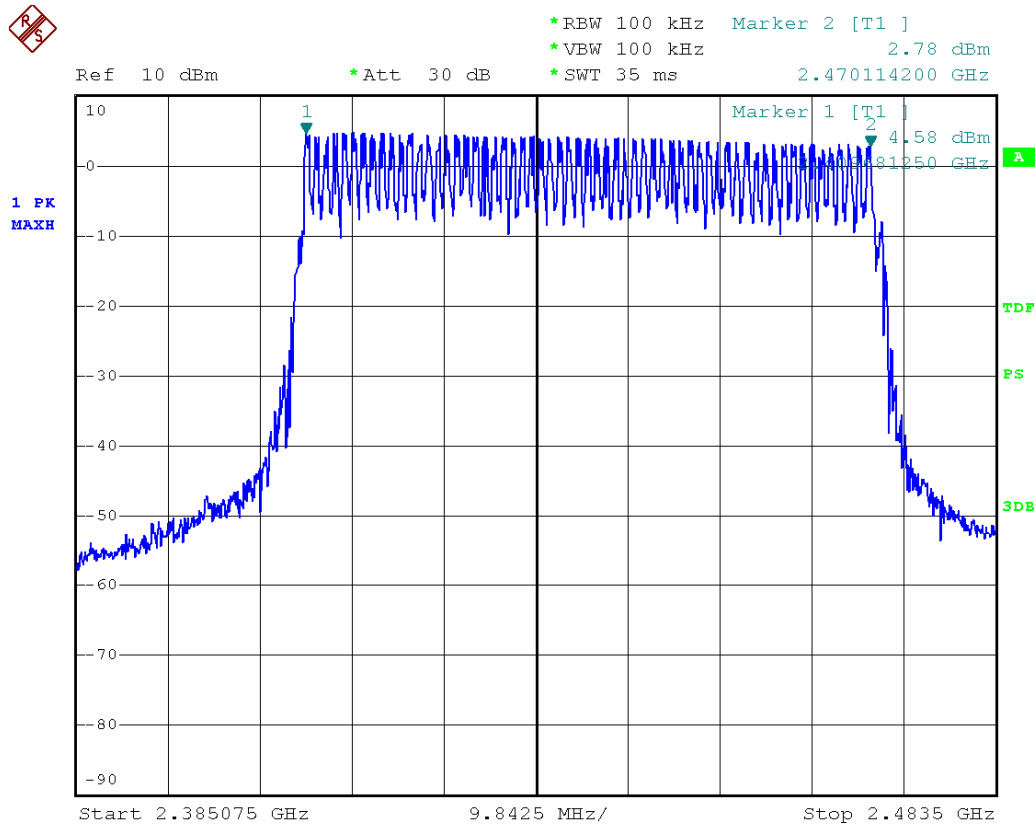

SLTG

Date: 26.SEP.2010 14:55:13

## 7. Average Time of Occupancy

### 7.1 Test Standard and Limit

- 5.1.1 Test Standard  
FCC Part 15.247 (a)(1)
- 5.1.2 Test Limit

FCC Part 15 Subpart C(15.247)		
Section	Test Item	Limit
15.247 (a)(1)	Average Time of Occupancy	0.4 sec

### 7.2 Test Setup

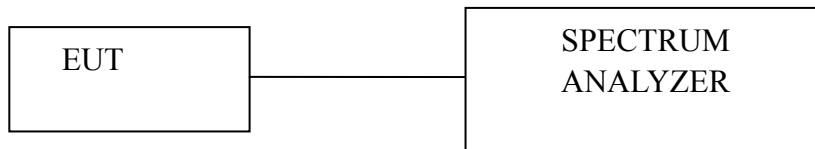

### 7.3 Test Procedure

- (1) The EUT was directly connected to the spectrum analyzer and antenna output port as show in the block diagram above.
- (2) Spectrum Setting: RBW=1 MHz, VBW=1 MHz.
- (3) Use video trigger with the trigger level set to enable triggering only on full pulses.
- (4) Sweep Time is more than once pulse time.
- (5) Set the center frequency on any frequency would be measure and set the frequency span to zero span.
- (6) Measure the maximum time duration of one single pulse.
- (7) Set the EUT for packet transmitting.
- (8) Measure the maximum time duration of one single pulse.

### 7.4 EUT Operating Condition

The EUT was set to the Hopping Mode by the Customer.

### 7.5 Test Equipment

Description	Manufacturer	Model No.	Serial No.	Cal. Date	Cal. Date
Spectrum Analyzer	ROHDE& SCHWARZ	FSEA20	DE25181	2010-08-12	2011-08-11

### 7.6 Test Data

Mode	Number of transmission in a 24.4s (61 Hopping*0.4)	Length of transmissions time(msec)	Result (msec)	Limit (msec)
Hopping Mode	$24.4*(8/2)=97.6$ times	0.96	93.696	400

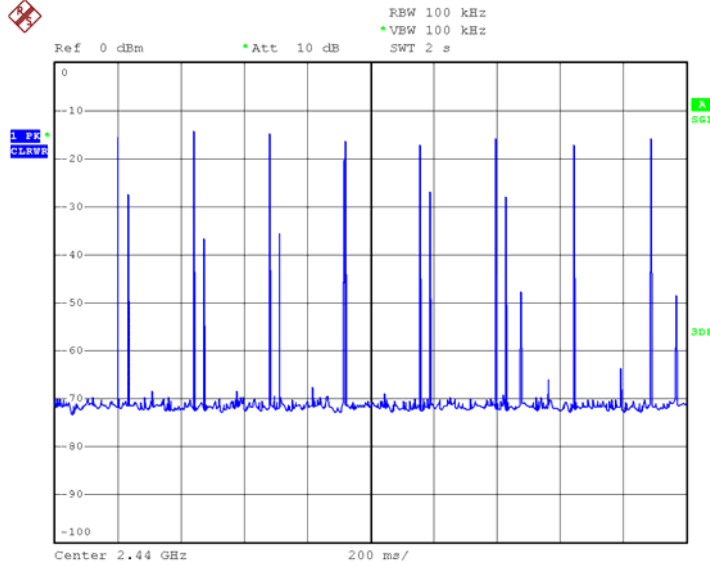

SLTG  
Date: 26.SEP.2010 15:10:05

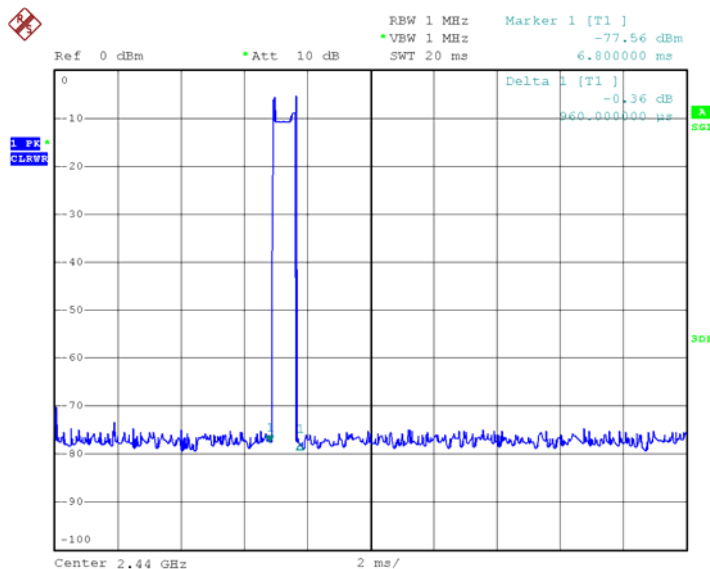

SLTG  
Date: 26.SEP.2010 15:08:02

## 8. Channel Separation and Bandwidth Test

### 8.1 Test Standard and Limit

#### 8.1.1 Test Standard

FCC Part 15.247

#### 8.1.2 Test Limit

FCC Part 15 Subpart C(15.247)		
Test Item	Limit	Frequency Range(MHz)
Bandwidth	$\leq 1$ MHz (20dB bandwidth)	2400~2483.5
Channel Separation	$>25$ KHz or $>$ two-thirds of the 20 dB bandwidth Which is greater	2400~2483.5

### 8.2 Test Setup



### 8.3 Test Procedure

- (1) The EUT was directly connected to the spectrum analyzer and antenna output port as show in the block diagram above.
- (2) Spectrum Setting:  
 Channel Separation: RBW=30 kHz, VBW=100 kHz.  
 Bandwidth: RBW=10 kHz, VBW=30 kHz.
- (3) The bandwidth is measured at an amplitude level reduced 20dB from the reference level. The reference level is the level of the highest amplitude signal observed from the transmitter at the fundamental frequency. Once the reference level is established, the equipment is conditioned with typical modulating signal to produce the worst –case (i.e the widest) bandwidth.
- (4) Measure the channel separation the spectrum analyzer was set to Resolution Bandwidth:30 kHz, and Video Bandwidth:100 kHz. Sweep Time set auto.

### 8.4 EUT Operating Condition

The EUT was set to the Hopping Mode for Channel Separation Test and continuously transmitting for the Bandwidth Test.

### 8.5 Test Equipment

Description	Manufacturer	Model No.	Serial No.	Cal. Date	Cal. Date
Spectrum Analyzer	ROHDE& SCHWARZ	FSEA20	DE25181	2010-08-12	2011-08-11

### 8.6 Test Data

Channel number	Channel frequency (MHz)	20dB Bandwidth (kHz)	Read Value*2/3 (kHz)
CH 00	2410	620.00	413.33
CH 30	2440	640.00	426.66
CH 60	2470	600.00	400.00

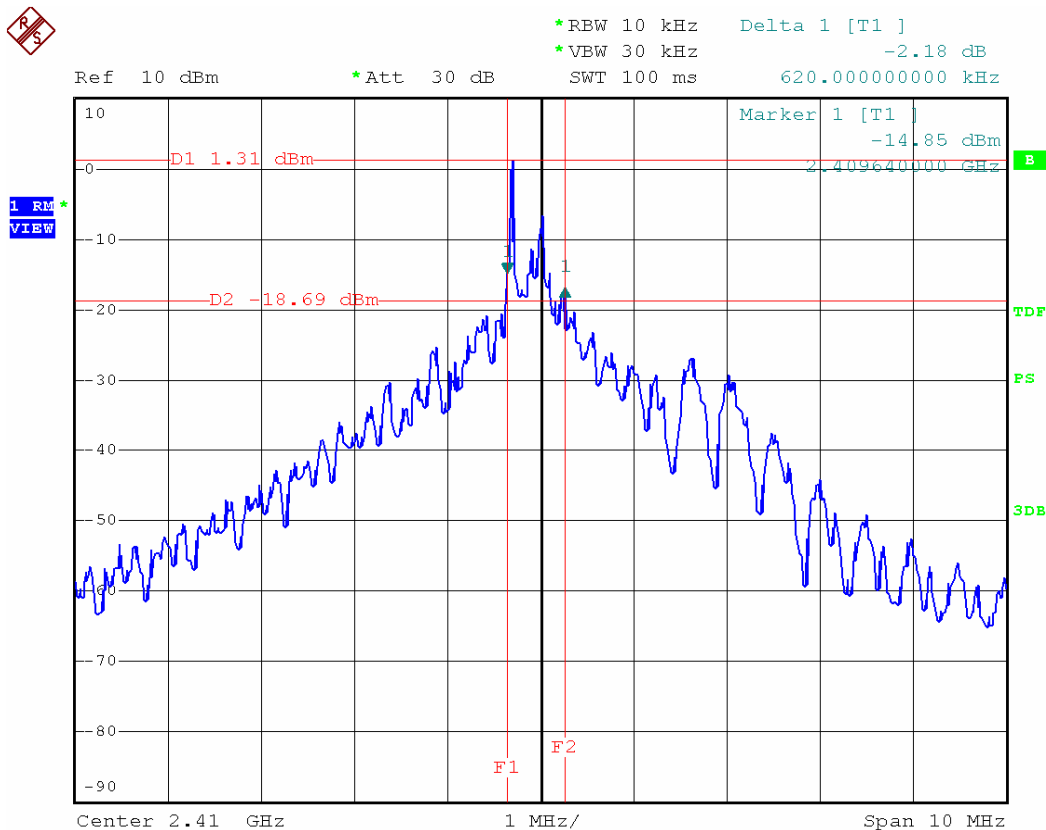



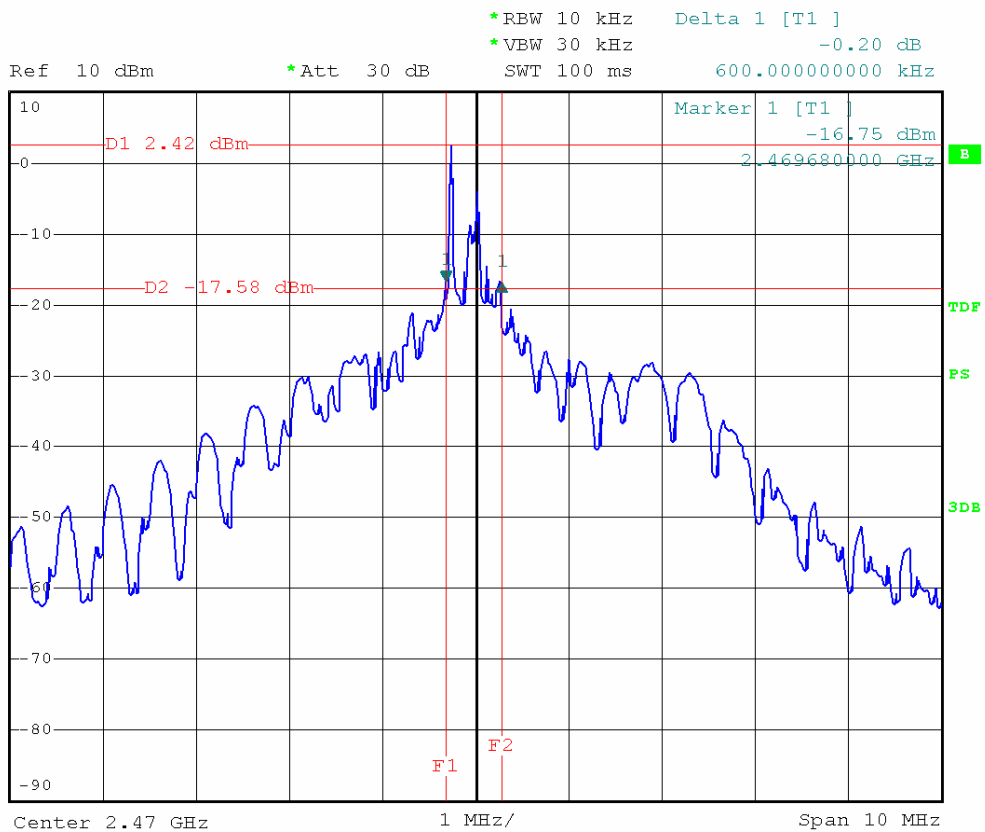
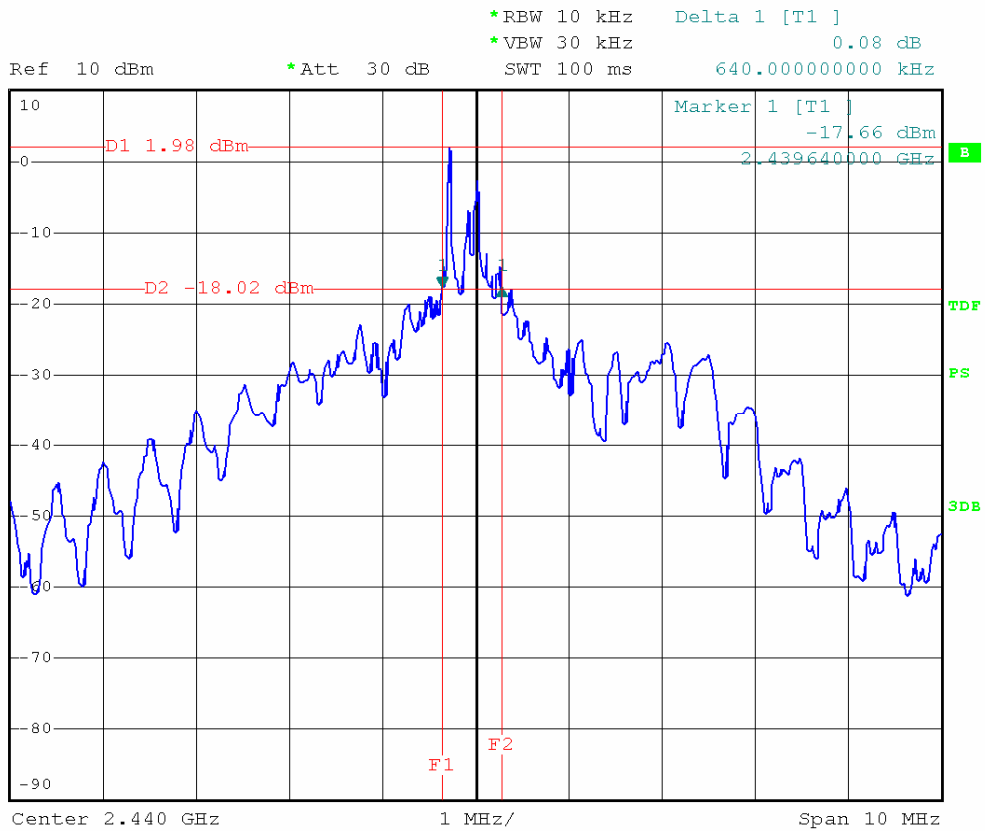

Channel number	Channel frequency (MHz)	Separation Read Value (kHz)	Separation Limit (kHz)
CH 00	2410	1001.00	>413.33kHz
CH 30	2440	1000.00	>426.66 kHz
CH 60	2470	1010.00	>400.00kHz

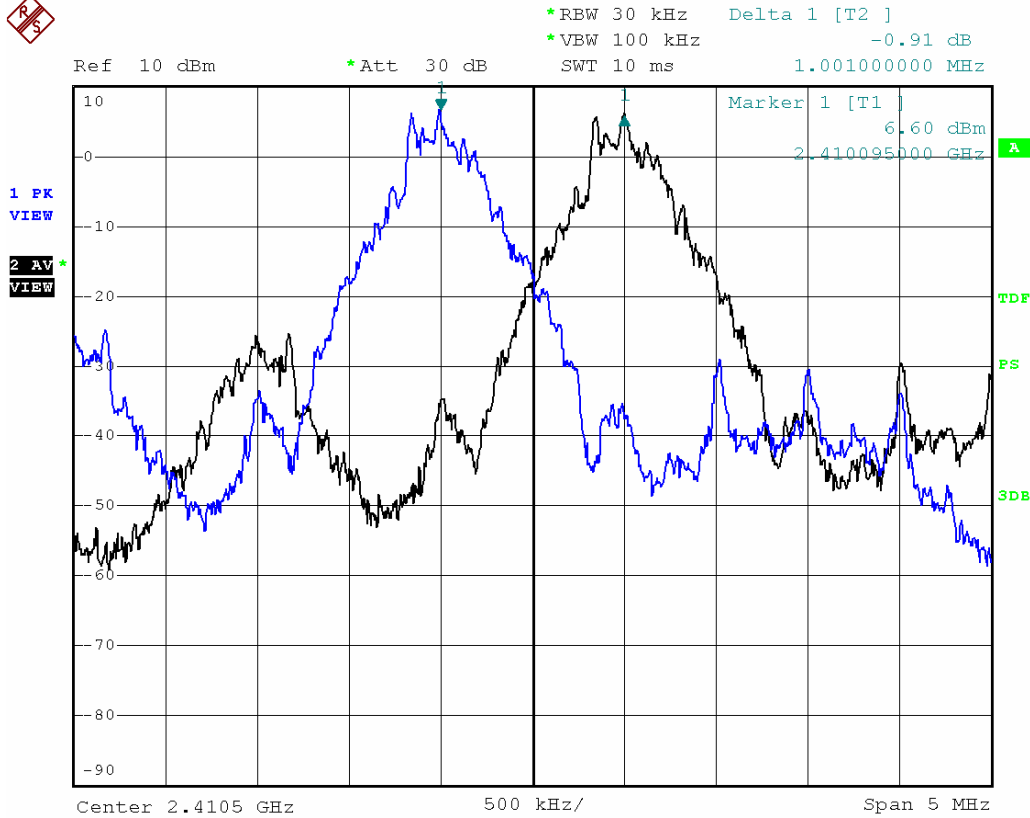

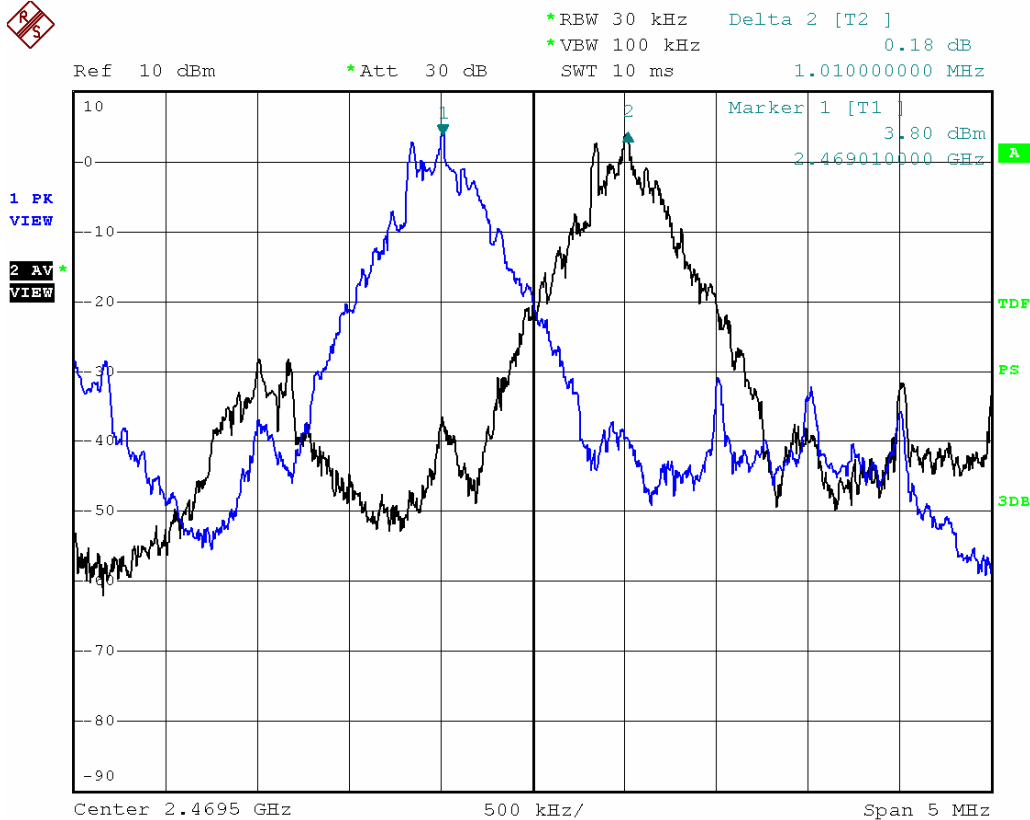
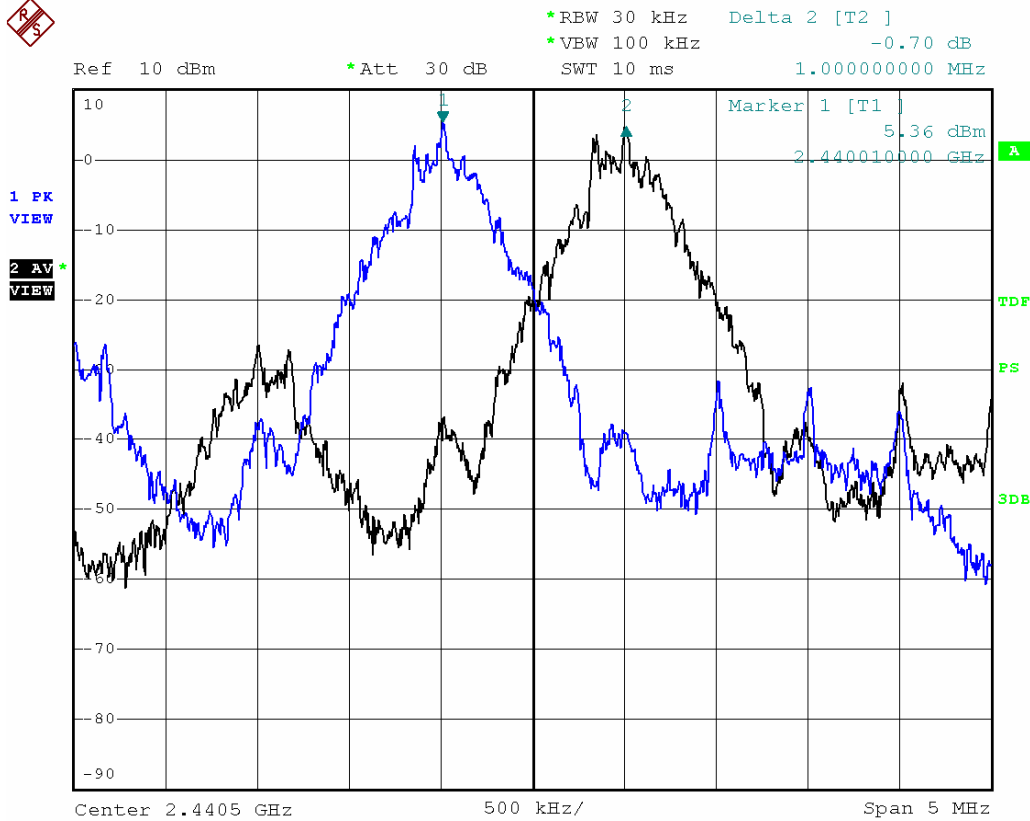

## 9. Peak Output Power Test

### 9.1 Test Standard and Limit

#### 9.1.1 Test Standard

FCC Part 15.247 (b) (1)

#### 9.1.2 Test Limit

FCC Part 15 Subpart C(15.247)		
Test Item	Limit	Frequency Range(MHz)
Peak Output Power	Hopping Channels>75 Power<1W(30 dBm) Other <125 mW	2400~2483.5

### 9.2 Test Setup



### 9.3 Test Procedure

- (1) The EUT was directly connected to the spectrum analyzer and antenna output port as show in the block diagram above.
- (2) Spectrum Setting:  
Channel Separation: RBW=1 MHz, VBW=1 MHz.

### 9.4 EUT Operating Condition

The EUT was set to continuously transmitting in the max power during the test.

### 9.5 Test Equipment

Description	Manufacturer	Model No.	Serial No.	Cal. Date	Cal. Date
Spectrum Analyzer	ROHDE& SCHWARZ	FSEA20	DE25181	2010-08-12	2011-08-11

### 8.6 Test Data

---

---

Channel number	Channel frequency (MHz)	Test Result (dBm)	Limit
CH 00	2410	10.63	125mW(21 dBm)
CH 30	2440	10.37	125mW(21 dBm)
CH 60	2470	10.16	125mW(21 dBm)

## 10. Antenna Conducted Spurious Emission

### 10.1 Test Standard and Limit

#### 10.1.1 Test Standard

FCC Part 15.247 (c)

#### 10.1.2 Test Limit

In any 100 kHz bandwidth outside the frequency band in which the spread spectrum or digitally modulated intentional radiator is operating, the radio frequency power that is produced by the intentional radiator shall be at least 20 dB below that in the 100 kHz bandwidth within the band that contains the highest level of the desired power. In case the emission fall within the restricted band specified on 15.205(a), then the 15.209(a) limit in the table below has to be followed.

Frequencies (MHz)	Field Strength (microvolt/meter)	Measurement Distance (meters)
0.009~0.490	2400/F(KHz)	300
0.490~1.705	24000/F(KHz)	30
1.705~30.0	30	30
30~88	100	3
88~216	150	3
216~960	200	3
Above~960	500	3

### 10.2 Test Setup



### 10.3 Test Procedure

- (1) The EUT was directly connected to the spectrum analyzer and antenna output port as show in the block diagram above.
- (2) Spectrum Setting:  
Channel Separation: RBW=100 KHz, VBW=100 KHz.  
Span: 100M for Band edge testing.

#### 10.4 EUT Operating Condition

The EUT was set to continuously transmitting in the max power during the test.

#### 10.5 Test Equipment

<b>Description</b>	<b>Manufacturer</b>	<b>Model No.</b>	<b>Serial No.</b>	<b>Cal. Date</b>	<b>Cal. Date</b>
Spectrum Analyzer	ROHDE& SCHWARZ	FSEA20	DE25181	2010-08-12	2011-08-11

#### 10.6 Test Data

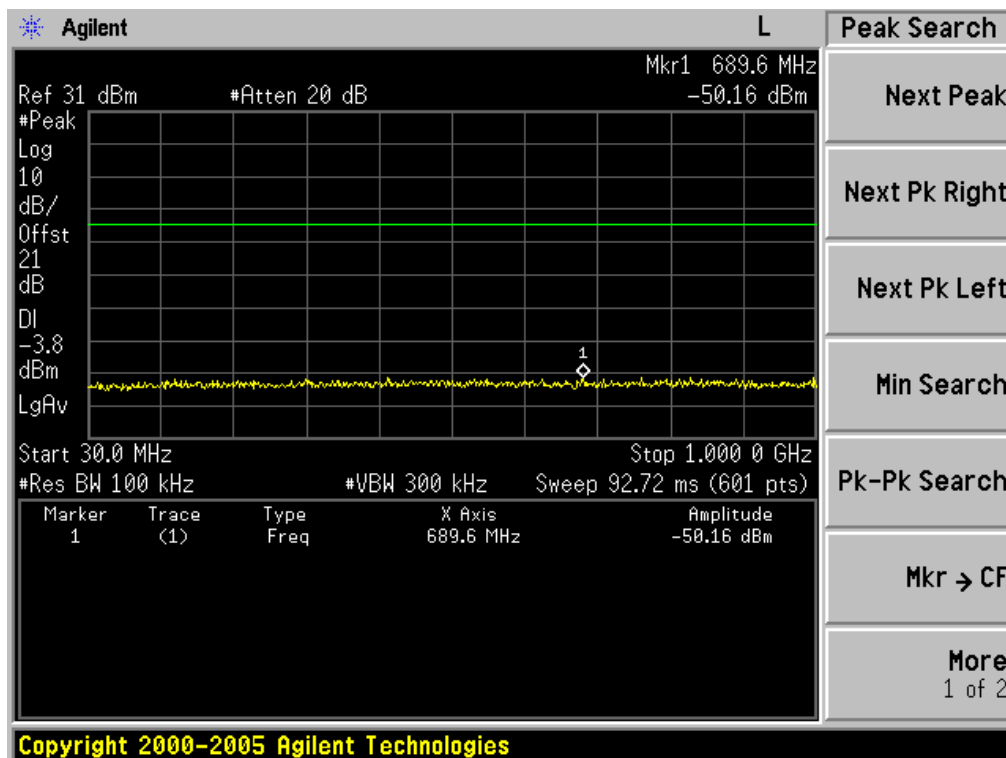
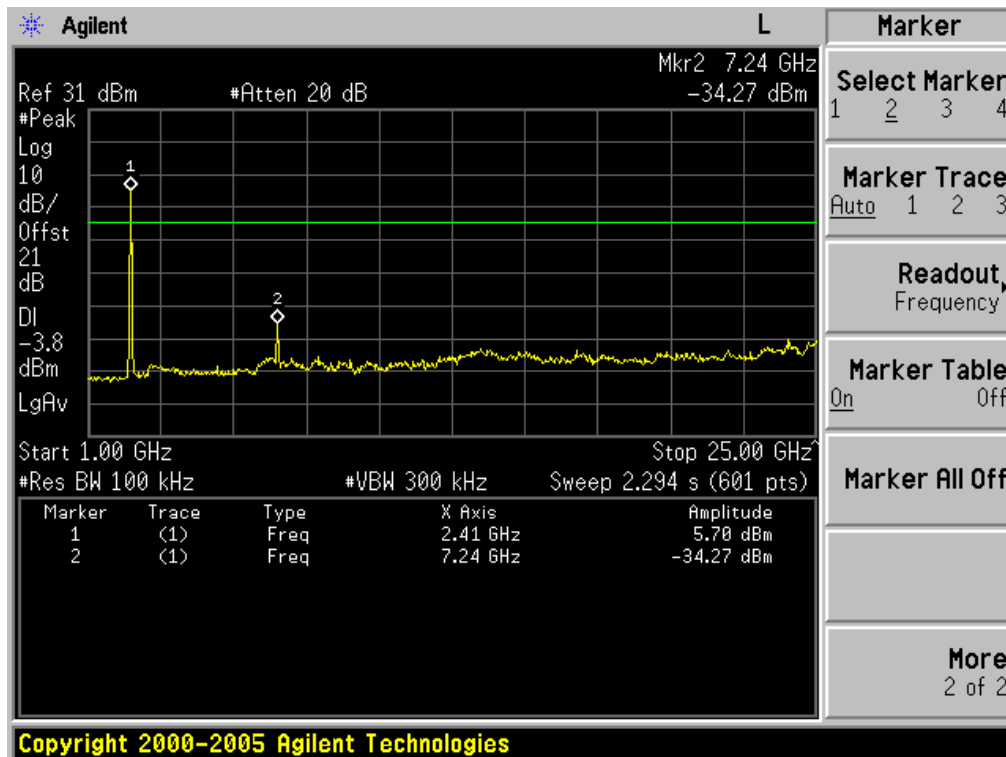



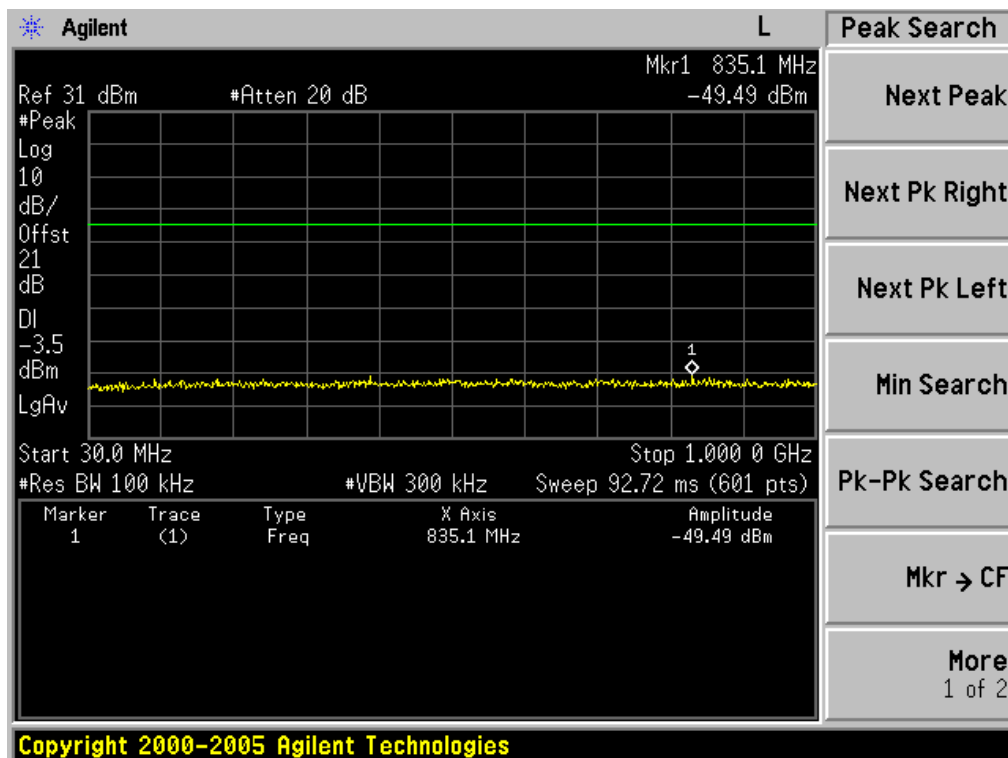
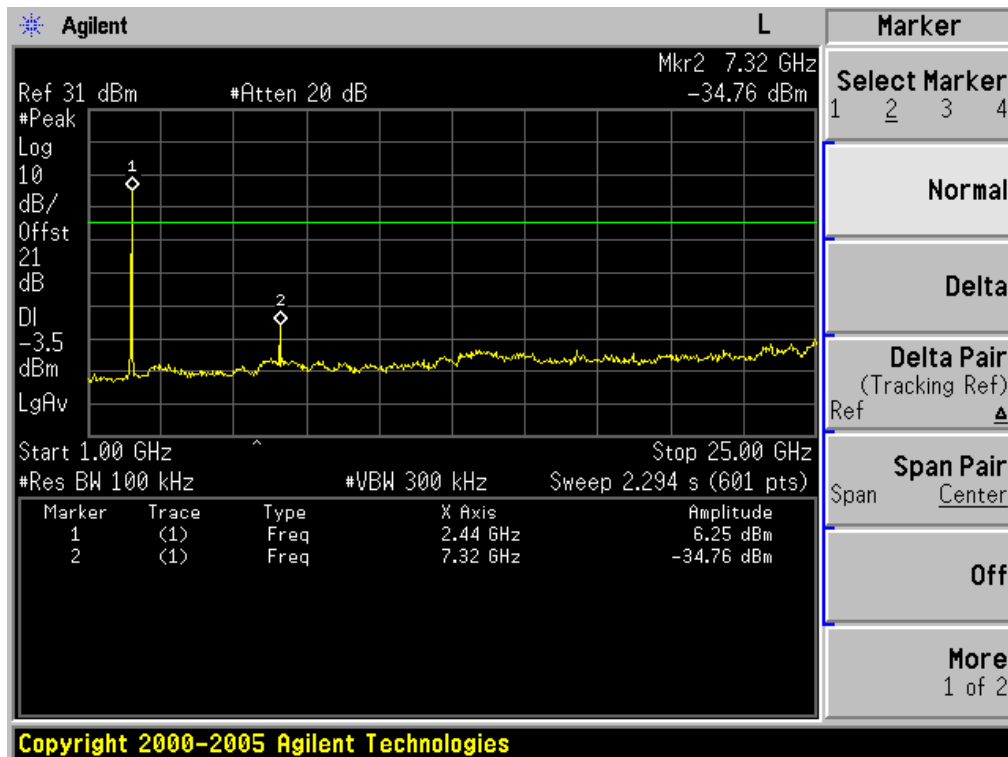

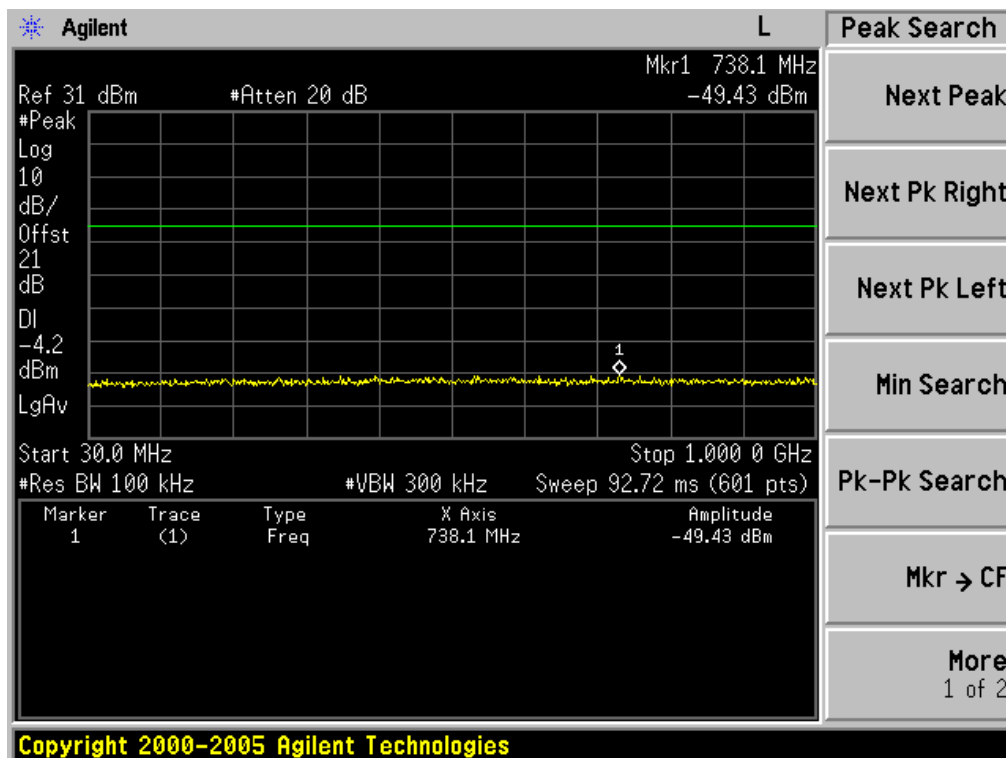
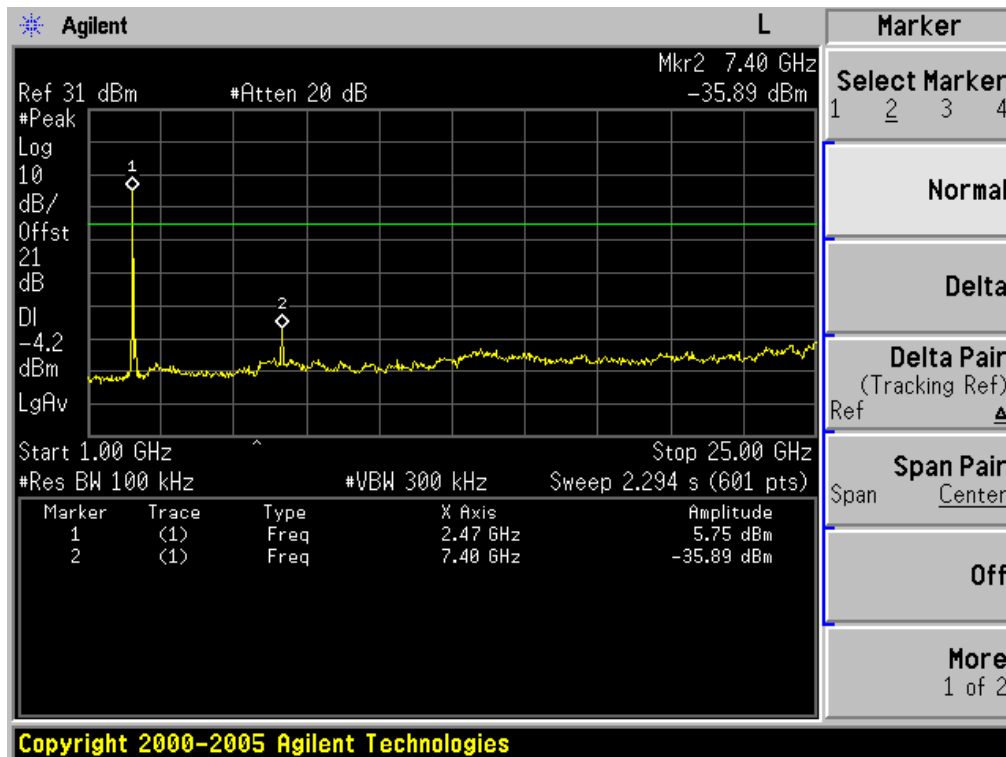

## 11. Antenna Requirement

### 11.1 Standard Requirement

#### 11.1.1 Standard

FCC Part 15.203

#### 11.1.2 Requirement

An intentional radiator shall be designed to ensure that no antenna other than that furnished by the responsible party shall be used with the device. The use of a permanently attached antenna or of an antenna that uses a unique coupling to the intentional radiator shall be considered sufficient to comply with the provisions of this Section. The manufacturer may design the unit so that a broken antenna can be replaced by the user, but the use of a standard antenna jack or electrical connector is prohibited.

### 11.2 Antenna Connected Construction

The directional gains of the antenna used for transmitting is 2.5 dBi, and the antenna connector is de-signed with permanent attachment and no consideration of replacement. Please see the EUT photo for details.

#### 11.2 Result

The EUT antenna is integral Antenna. It complies with the standard requirement.