

SAR EVALUATION REPORT

For

ITALCOM GROUP

1728 Coral Way, Coral Gables, Miami, Florida, United States

FCC ID: YPVMIFIAMR510

Report Type: Original Report	Product Type: Mobile LTE Wi-Fi Router
Test Engineer: Sandy Wang	<i>Sandy Wang</i>
Report Number: RSZ130204002-20	
Report Date: 2013-03-29	
Reviewed By: Alvin Huang RF Leader	<i>Alvin Huang</i>
Test Laboratory:	Bay Area Compliance Laboratories Corp. (Shenzhen) 6/F, the 3rd Phase of WanLi Industrial Building, ShiHua Road, FuTian Free Trade Zone Shenzhen, Guangdong, China Tel: +86-755-33320018 Fax: +86-755-33320008 www.baclcorp.com.cn

Note: This test report is prepared for the customer shown above and for the device described herein. It may not be duplicated or used in part without prior written consent from Bay Area Compliance Laboratories Corp.

Attestation of Test Results			
EUT Information	Company Name	ITALCOM GROUP	
	EUT Description	Mobile LTE WiFi Router	
	FCC ID	YPVMIFIAMR510	
	Model Number	MiFi LTE	
	Test Date	2013-03-24 to 2013-03-25	
Frequency	Max. SAR Level(s) Measured	Limit(W/Kg)	
WCDMA850	0.492 W/kg 1g Body SAR	1.6	
WCDMA1900	1.343 W/kg 1g Body SAR		
LTE Band 4	1 RB		1.193 W/kg 1g Body SAR
	50 RB		1.024 W/kg 1g Body SAR
	100 RB		1.126 W/kg 1g Body SAR
WiFi (802.11g)	0.110 W/kg 1g Body SAR		
Hot Spot	1.364 W/kg 1g Body SAR		
Applicable Standards	ANSI / IEEE C95.1 : 2005 IEEE Standard for Safety Levels with Respect to Human Exposure to Radio Frequency Electromagnetic Fields,3 kHz to 300 GHz.		
	ANSI / IEEE C95.3 : 2002 IEEE Recommended Practice for Measurements and Computations of Radio Frequency Electromagnetic Fields With Respect to Human Exposure to SuchFields,100 kHz—300 GHz.		
	OET BULLETIN 65 SUPPLEMENT C Evaluating Compliance with FCC Guidelines for Human Exposure To Radiofrequency Electromagnetic Fields		
	IEEE1528:2003 IEEE Recommended Practice for Determining the Peak Spatial-Average Specific Absorption Rate (SAR) in the Human Head from Wireless Communications Devices: Measurement Techniques		
<p>Note: This wireless device has been shown to be capable of compliance for localized specific absorption rate (SAR) for General Population/Uncontrolled Exposure limits specified in ANSI/IEEE Standards and has been tested in accordance with the measurement procedures specified in FCC OET 65 Supplement C and IEEE 1528-2003.</p> <p>The results and statements contained in this report pertain only to the device(s) evaluated.</p>			

TABLE OF CONTENTS

DOCUMENT REVISION HISTORY	4
EUT DESCRIPTION	5
TECHNICAL SPECIFICATION	5
REFERENCE, STANDARDS, AND GUIDELINES	6
SAR LIMITS	7
FACILITIES	8
DESCRIPTION OF TEST SYSTEM	9
EQUIPMENT LIST AND CALIBRATION	16
EQUIPMENTS LIST & CALIBRATION INFORMATION	16
SAR MEASUREMENT SYSTEM VERIFICATION	17
LIQUID VERIFICATION	17
SYSTEM ACCURACY VERIFICATION	20
SAR SYSTEM VALIDATION DATA	21
EUT TEST STRATEGY AND METHODOLOGY	29
TEST POSITIONS FOR DEVICE OPERATING NEXT TO A PERSON’S EAR	29
CHEEK/TOUCH POSITION	30
EAR/TILT POSITION	30
TEST POSITIONS FOR BODY-WORN AND OTHER CONFIGURATIONS	31
SAR EVALUATION PROCEDURE	32
CONDUCTED OUTPUT POWER MEASUREMENT	33
PROVISION APPLICABLE	33
TEST PROCEDURE	33
TEST RESULTS:	34
SAR MEASUREMENT RESULTS	42
SAR TEST DATA	42
SAR SIMULTANEOUS TRANSMISSION DESCRIPTION	46
EUT SCAN RESULTS	49
APPENDIX A – MEASUREMENT UNCERTAINTY	79
APPENDIX B – PROBE CALIBRATION CERTIFICATES	80
APPENDIX C – DIPOLE CALIBRATION CERTIFICATES	90
APPENDIX D EUT TEST POSITION PHOTOS	129
LIQUID DEPTH \geq 15CM	129
BODY-WORN-HEADSET FRONT SETUP PHOTO	129
BODY-WORN-HEADSET BACK SETUP PHOTO	130
BODY-LEFT SETUP PHOTO	130
BODY-RIGHT SETUP PHOTO	131
BODY-BOTTOM SETUP PHOTO	131
BODY-TOP SETUP PHOTO	132
APPENDIX E EUT PHOTOS	133
EUT – FRONT VIEW	133
EUT – BACK VIEW	133
EUT – RIGHT VIEW	134
EUT – LEFT VIEW	134
EUT – UNCOVERED VIEW	135
APPENDIX F INFORMATIVE REFERENCES	136

DOCUMENT REVISION HISTORY

Revision Number	Report Number	Description of Revision	Date of Revision
0	RSZ130204002-20	Original Report	2013-03-29

EUT DESCRIPTION

This report has been prepared on behalf of ITALCOM GROUP and their product, FCC ID: YPVMIFIAMR510, Model: MiFi LTE or the EUT (Equipment under Test) as referred to in the rest of this report. The EUT is a Mobile LTE WiFi Router.

Technical Specification

Product Type	Portable
Exposure Category:	Population / Uncontrolled
Antenna Type(s):	Internal Antenna
Body-Worn Accessories:	None
Face-Head Accessories:	None
Operation Mode :	WCDMA, LTE and WiFi
Frequency Band:	WCDMA850: 824-849MHz(TX); 869-894MHz(RX) WCDMA1900: 1850-1910MHz(TX); 1930-1990MHz(RX) LTE Band 4: 1710-1755MHz(TX); 2110-2155MHz(RX) WiFi (802.11b/g/n) : 2412MHz-2462MHz
Conducted RF Power:	WCDMA850:23.16dBm WCDMA1900: 22.78dBm LTE Band 4: 23.08dBm WiFi(802.11b/g/n) :19.88dBm
Dimensions (L*W*H):	99 mm (L) × 55 mm (W) × 11 mm (H)
Weight:	94.6g
Power Source:	3.7 VDC/2100mAh Rechargeable Battery
Normal Operation:	Body-worn

REFERENCE, STANDARDS, AND GUIDELINES

FCC:

The Report and Order requires routine SAR evaluation prior to equipment authorization of portable transmitter devices, including portable telephones. For consumer products, the applicable limit is 1.6 mW/g as recommended by the ANSI/IEEE standard C95.1-1992 [6] for an uncontrolled environment (Paragraph 65). According to the Supplement C of OET Bulletin 65 "Evaluating Compliance with FCC Guide-lines for Human Exposure to Radio frequency Electromagnetic Fields", released on Jun 29, 2001 by the FCC, the device should be evaluated at maximum output power (radiated from the antenna) under "worst-case" conditions for normal or intended use, incorporating normal antenna operating positions, device peak performance frequencies and positions for maximum RF energy coupling.

This report describes the methodology and results of experiments performed on wireless data terminal. The objective was to determine if there is RF radiation and if radiation is found, what is the extent of radiation with respect to safety limits. SAR (Specific Absorption Rate) is the measure of RF exposure determined by the amount of RF energy absorbed by human body (or its parts) – to determine how the RF energy couples to the body or head which is a primary health concern for body worn devices. The limit below which the exposure to RF is considered safe by regulatory bodies in North America is 1.6 mW/g average over 1 gram of tissue mass.

CE:

The order requires routine SAR evaluation prior to equipment authorization of portable transmitter devices, including portable telephones. For consumer products, the applicable limit is 2 mW/g as recommended by EN62209-1 for an uncontrolled environment. According to the Standard, the device should be evaluated at maximum output power (radiated from the antenna) under "worst-case" conditions for normal or intended use, incorporating normal antenna operating positions, device peak performance frequencies and positions for maximum RF energy coupling.

This report describes the methodology and results of experiments performed on wireless data terminal. The objective was to determine if there is RF radiation and if radiation is found, what is the extent of radiation with respect to safety limits. SAR (Specific Absorption Rate) is the measure of RF exposure determined by the amount of RF energy absorbed by human body (or its parts) – to determine how the RF energy couples to the body or head which is a primary health concern for body worn devices. The limit below which the exposure to RF is considered safe by regulatory bodies in Europe is 2 mW/g average over 10 gram of tissue mass.

The test configurations were laid out on a specially designed test fixture to ensure the reproducibility of measurements. Each configuration was scanned for SAR. Analysis of each scan was carried out to characterize the above effects in the device.

SAR Limits

FCC Limit (1g Tissue)

EXPOSURE LIMITS	SAR (W/kg)	
	(General Population / Uncontrolled Exposure Environment)	(Occupational / Controlled Exposure Environment)
Spatial Average (averaged over the whole body)	0.08	0.4
Spatial Peak (averaged over any 1 g of tissue)	1.60	8.0
Spatial Peak (hands/wrists/feet/ankles averaged over 10 g)	4.0	20.0

CE Limit (10g Tissue)

EXPOSURE LIMITS	SAR (W/kg)	
	(General Population / Uncontrolled Exposure Environment)	(Occupational / Controlled Exposure Environment)
Spatial Average (averaged over the whole body)	0.08	0.4
Spatial Peak (averaged over any 10 g of tissue)	2.0	10
Spatial Peak (hands/wrists/feet/ankles averaged over 10 g)	4.0	20.0

Population/Uncontrolled Environments are defined as locations where there is the exposure of individual who have no knowledge or control of their exposure.

Occupational/Controlled Environments are defined as locations where there is exposure that may be incurred by people who are aware of the potential for exposure (i.e. as a result of employment or occupation).

General Population/Uncontrolled environments Spatial Peak limit 1.6W/kg (FCC) & 2 W/kg (CE) applied to the EUT.

FACILITIES

The test site used by Bay Area Compliance Laboratories Corp. (Shenzhen) to collect data is located at 6/F, the 3rd Phase of WanLi Industrial Building, Shi Hua Road, Fu Tian Free Trade Zone, Shenzhen, Guangdong, P.R. of China

DESCRIPTION OF TEST SYSTEM

These measurements were performed with ALSAS 10 Universal Integrated SAR Measurement system from APREL Laboratories.

ALSAS-10U System Description

ALSAS-10-U is fully compliant with the technical and scientific requirements of IEEE 1528, IEC 62209, CENELEC, ARIB, ACA, and the Federal Communications Commission. The system comprises of a six axes articulated robot which utilizes a dedicated controller. ALSAS-10U uses the latest methodologies. And FDTD modeling to provide a platform which is repeatable with minimum uncertainty.

Applications

Predefined measurement procedures compliant with the guidelines of CENELEC, IEEE, IEC, FCC, etc are utilized during the assessment for the device. Automatic detection for all SAR maxima are embedded within the core architecture for the system, ensuring that peak locations used for centering the zoom scan are within a 1mm resolution and a 0.05mm repeatable position. System operation range currently available up-to 6 GHz in simulated tissue.

Area Scans

Area scans are defined prior to the measurement process being executed with a user defined variable spacing between each measurement point (integral) allowing low uncertainty measurements to be conducted. Scans defined for FCC applications utilize a 10mm² step integral, with 1mm interpolation used to locate the peak SAR area used for zoom scan assessments.

Where the system identifies multiple SAR peaks (which are within 25% of peak value) the system will provide the user with the option of assessing each peak location individually for zoom scan averaging.

Zoom Scan (Cube Scan Averaging)

The averaging zoom scan volume utilized in the ALSAS-10U software is in the shape of a cube and the side dimension of a 1 g or 10 g mass is dependent on the density of the liquid representing the simulated tissue. A density of 1000 kg/m³ is used to represent the head and body tissue density and not the phantom liquid density, in order to be consistent with the definition of the liquid dielectric properties, i.e. the side length of the 1 g cube is 10mm, with the side length of the 10 g cube 21,5mm.

When the cube intersects with the surface of the phantom, it is oriented so that 3 vertices touch the surface of the shell or the center of a face is tangent to the surface. The face of the cube closest to the surface is modified in order to conform to the tangent surface.

The zoom scan integer steps can be user defined so as to reduce uncertainty, but normal practice for typical test applications (including FCC) utilize a physical step of 5x5x8 (8mmx8mmx5mm) providing a volume of 32mm³ in the X & Y axis, and 35mm in the Z axis.



ALSAS-10U Interpolation and Extrapolation Uncertainty

The overall uncertainty for the methodology and algorithms the used during the SAR calculation was evaluated using the data from IEEE 1528 based on the example f3 algorithm:

$$f_3(x, y, z) = A \frac{a^2}{\frac{a^2}{4} + x'^2 + y'^2} \cdot \left(e^{-\frac{2z}{a}} + \frac{a^2}{2(a + 2z)^2} \right)$$

Isotropic E-Field Probe

The isotropic E-Field probe has been fully calibrated and assessed for isotropicity, and boundary effect within a controlled environment. Depending on the frequency for which the probe is calibrated the method utilized for calibration will change.

The E-Field probe utilizes a triangular sensor arrangement as detailed in the diagram below:

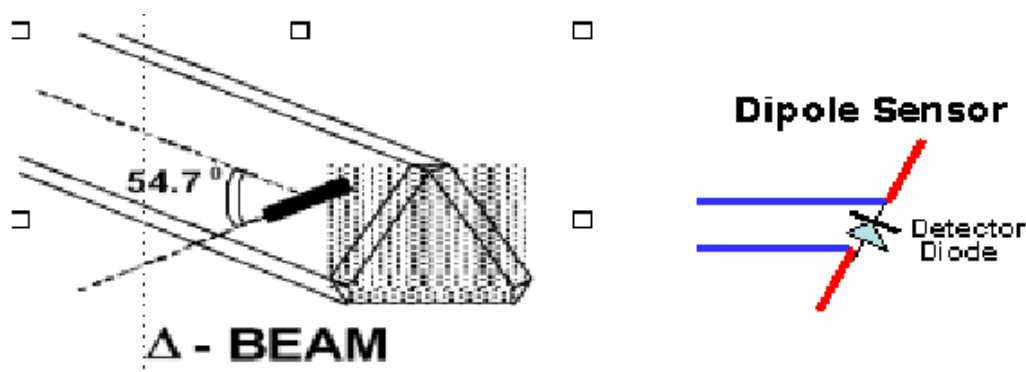

SAR is assessed with a calibrated probe which moves at a default height of 5mm from the center of the diode, which is mounted to the sensor, to the phantom surface (in the Z Axis). The 5mm offset height has been selected so as to minimize any resultant boundary effect due to the probe being in close proximity to the phantom surface.

The following algorithm is an example of the function used by the system for linearization of the output from the probe when measuring complex modulation schemes.

$$V_i = U_i + U_i^2 \cdot \frac{cf}{dcp_i}$$

Isotropic E-Field Probe Specification

Calibration Method	Frequency Dependent Below 1 GHz Calibration in air performed in a TEM Cell Above 1 GHz Calibration in air performed in waveguide
Sensitivity	0.70 $\mu\text{V}/(\text{V}/\text{m})^2$ to 0.85 $\mu\text{V}/(\text{V}/\text{m})^2$
Dynamic Range	0.0005 W/kg to 100 W/kg
Isotropic Response	Better than 0.1 dB
Diode Compression Point (DCP)	Calibration for Specific Frequency
Probe Tip Diameter	< 2.9 mm
Sensor Offset	1.56 (+/- 0.02 mm)
Probe Length	289 mm
Video Bandwidth	@ 500 Hz: 1 dB @ 1.02 kHz: 3 dB
Boundary Effect	Less than 2.1% for distance greater than 0.58 mm
Spatial Resolution	The spatial resolution uncertainty is less than 1.5% for 4.9mm diameter probe. The spatial resolution uncertainty is less than 1.0% for 2.5mm diameter probe

Boundary Detection Unit and Probe Mounting Device

ALSAS-10U incorporates a boundary detection unit with a sensitivity of 0.05mm for detecting all types of surfaces. The robust design allows for detection during probe tilt (probe normalize) exercises, and utilizes a second stage emergency stop. The signal electronics are fed directly into the robot controller for high accuracy surface detection in lateral and axial detection modes (X, Y, & Z).

The probe is mounted directly onto the Boundary Detection unit for accurate tooling and displacement calculations controlled by the robot kinematics. The probe is connect to an isolated probe interconnect where the output stage of the probe is fed directly into the amplifier stage of the Daq-Paq.

Daq-Paq (Analog to Digital Electronics)

ALSAS-10U incorporates a fully calibrated Daq-Paq (analog to digital conversion system) which has a 4 channel input stage, sent via a 2 stage auto-set amplifier module. The input signal is amplified accordingly so as to offer a dynamic range from 5 μV to 800mV. Integration of the fields measured is carried out at board level utilizing a Co-Processor which then sends the measured fields down into the main computational module in digitized form via an RS232 communications port. Probe linearity and duty cycle compensation is carried out within the main Daq-Paq module.

ADC	12 Bit
Amplifier Range	20 mV to 200 mV and 150 mV to 800 mV
Field Integration	Local Co-Processor utilizing proprietary integration algorithms
Number of Input Channels	4 in total 3 dedicated and 1 spare
Communication	Packet data via RS232

Axis Articulated Robot

ALSAS-10U utilizes a six axis articulated robot, which is controlled using a Pentium based real-time movement controller. The movement kinematics engine utilizes proprietary (Thermo CRS) interpolation and extrapolation algorithms, which allow full freedom of movement for each of the six joints within the working envelope. Utilization of joint 6 allows for full probe rotation with a tolerance better than 0.05mm around the central axis.



Robot/Controller Manufacturer	Thermo CRS
Number of Axis	Six independently controlled axis
Positioning Repeatability	0.05 mm
Controller Type	Single phase Pentium based C500C
Robot Reach	710 mm
Communication	RS232 and LAN compatible

ALSAS Universal Workstation

ALSAS Universal workstation allows for repeatability and fast adaptability. It allows users to do calibration, testing and measurements using different types of phantoms with one set up, which significantly speeds up the measurement process.

Universal Device Positioner

The universal device positioner allows complete freedom of movement of the EUT. Developed to hold a EUT in a free-space scenario any additional loading attributable to the material used in the construction of the positioner has been eliminated. Repeatability has been enhanced through the linear scales which form the design used to indicate positioning for any given test scenario in all major axes. A 15° tilt indicator is included for the of aid cheek to tilt movements for head SAR analysis. Overall uncertainty for measurements have been reduced due to the design of the Universal device positioner, which allows positioning of a device in as near to a free-space scenario as possible, and by providing the means for complete repeatability.



Phantom Types

The ALSAS-10U allows the integration of multiple phantom types. SAM Phantoms fully compliant with IEEE 1528, Universal Phantom, and Universal Flat.

APREL SAM Phantoms

The SAM phantoms developed using the IEEE SAM CAD file. They are fully compliant with the requirements for both IEEE 1528 and FCC Supplement C. Both the left and right SAM phantoms are interchangeable, transparent and include the IEEE 1528 grid with visible NF and MB lines.

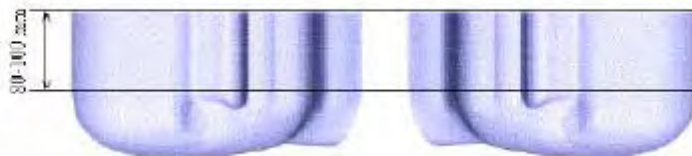

APREL Laboratories Universal Phantom

The Universal Phantom is used on the ALSAS-10U as a system validation phantom. The Universal Phantom has been fully validated both experimentally from 800MHz to 6GHz and numerically using XFDTD numerical software.

The shell thickness is 2mm overall, with a 4mm spacer located at the NF/MB intersection providing an overall thickness of 6mm in line with the requirements of IEEE-1528.

The design allows for fast and accurate measurements, of handsets, by allowing the conservative SAR to be evaluated at on frequency for both left and right head experiments in one measurement.



Tissue Dielectric Parameters for Head and Body Phantoms

The head tissue dielectric parameters recommended by the IEEE SCC-34/SC-2 in P1528 have been incorporated in the following table. These head parameters are derived from planar layer models simulating the highest expected SAR for the dielectric properties and tissue thickness variations in a human head. Other head and body tissue parameters that have not been specified in P1528 are derived from the tissue dielectric parameters computed from the 4-Cole-Cole equations described in Reference [12] and extrapolated according to the head parameters specified in P1528.

Ingredients (% by weight)	Frequency (MHz)									
	450		835		915		1900		2450	
Tissue Type	Head	Body	Head	Body	Head	Body	Head	Body	Head	Body
Water	38.56	51.16	41.45	52.4	41.05	56.0	54.9	40.4	62.7	73.2
Salt (Nacl)	3.95	1.49	1.45	1.4	1.35	0.76	0.18	0.5	0.5	0.04
Sugar	56.32	46.78	56.0	45.0	56.5	41.76	0.0	58.0	0.0	0.0
HEC	0.98	0.52	1.0	1.0	1.0	1.21	0.0	1.0	0.0	0.0
Bactericide	0.19	0.05	0.1	0.1	0.1	0.27	0.0	0.1	0.0	0.0
Triton x-100	0.0	0.0	0.0	0.0	0.0	0.0	0.0	0.0	36.8	0.0
DGBE	0.0	0.0	0.0	0.0	0.0	0.0	44.92	0.0	0.0	26.7
Dielectric Constant	43.42	58.0	42.54	56.1	42.0	56.8	39.9	54.0	39.8	52.5
Conductivity (s/m)	0.85	0.83	0.91	0.95	1.0	1.07	1.42	1.45	1.88	1.78

Recommended Tissue Dielectric Parameters for Head and Body

Frequency (MHz)	Head Tissue		Body Tissue	
	ϵ_r	σ (S/m)	ϵ_r	σ (S/m)
150	52.3	0.76	61.9	0.80
300	45.3	0.87	58.2	0.92
450	43.5	0.87	56.7	0.94
835	41.5	0.90	55.2	0.97
900	41.5	0.97	55.0	1.05
915	41.5	0.98	55.0	1.06
1450	40.5	1.20	54.0	1.30
1610	40.3	1.29	53.8	1.40
1800-2000	40.0	1.40	53.3	1.52
2450	39.2	1.80	52.7	1.95
3000	38.5	2.40	52.0	2.73
5800	35.3	5.27	48.2	6.00

EQUIPMENT LIST AND CALIBRATION

Equipments List & Calibration Information

Equipment	Model	Calibration Date	S/N
CRS F3 robot	ALS-F3	N/A	RAF0805352
CRS F3 Software	ALS-F3-SW	N/A	N/A
CRS C500C controller	ALS-C500	N/A	RCF0805379
Probe mounting device & Boundary Detection Sensor System	ALS-PMDPS-3	N/A	120-00270
Universal Work Station	ALS-UWS	N/A	100-00157
Data Acquisition Package	ALS-DAQ-PAQ-3	2012-05-13	110-00212
Miniature E-Field Probe	ALS-E-020	2012-08-09	500-00283
Dipole, 835MHz	ALS-D-835-S-2	2011-08-25	180-00558
Dipole, 1800MHz	ALS-D-1800-S-2	2011-08-25	200-00659
Dipole, 1900MHz	ALS-D-1900-S-2	2011-08-25	210-00710
Dipole,2450MHz	ALS-D-2450-S-2	2011-08-25	220-00758
Dipole Spacer	ALS-DS-U	N/A	250-00907
Device holder/Positioner	ALS-H-E-SET-2	N/A	170-00510
Left ear SAM phantom	ALS-P-SAM-L	N/A	130-00311
Right ear SAM phantom	ALS-P-SAM-R	N/A	140-00359
UniPhantom	ALS-P-UP-1	N/A	150-00413
Simulated Tissue 835 MHz Body	ALS-TS-835-B	Each Time	270-02101
Simulated Tissue 1800 MHz Body	ALS-TS-1800-B	Each Time	290-02201
Simulated Tissue 1900 MHz Body	ALS-TS-1900-B	Each Time	295-02102
Simulated Tissue 2450 MHz Body	ALS-TS-2450-B	Each Time	290-01109
Power Amplifier	5S1G4	N/A	71377
Synthesized Sweeper	HP 8341B	2012-05-17	2624A00116
UNIVERSAL RADIO COMMUNICATION TESTER	CMU 200	2012-05-28	1100.0008.02
WIDEBAND RADIO COMMUNICATION TESTER	CMW500	N/A	20-360736
EMI Test Receiver	ESCI	2012-08-08	101122

SAR MEASUREMENT SYSTEM VERIFICATION

Liquid Verification

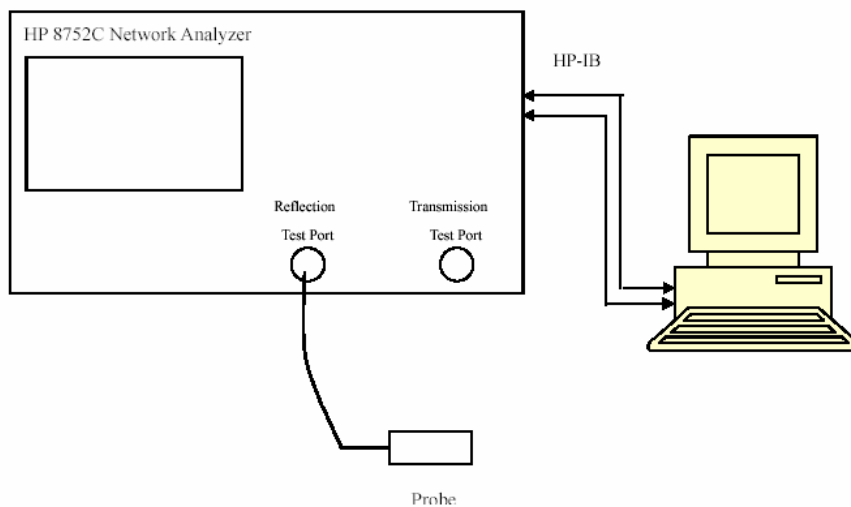

Liquid Verification Setup Block Diagram

Liquid Verification Results

Frequency	Liquid Type	Liquid Parameter		Target Value		Delta (%)		Tolerance (%)
		ϵ_r	O (S/m)	ϵ_r	O (S/m)	$\Delta\epsilon_r$	ΔO (S/m)	
826.4	Body	54.80	0.95	55.20	0.97	-0.725	-2.062	±5
836.6	Body	54.86	0.96	55.20	0.97	-0.616	-1.031	±5
846.6	Body	54.92	0.98	55.20	0.97	-0.507	1.031	±5
1720.0	Body	53.44	1.50	53.30	1.52	0.263	-1.316	±5
1732.5	Head	53.76	1.53	53.30	1.52	0.863	0.658	±5
1745.0	Body	53.77	1.55	53.30	1.52	0.882	1.974	±5
1852.4	Body	54.02	1.48	53.30	1.52	1.351	-2.632	±5
1880.0	Body	53.82	1.52	53.30	1.52	0.976	0.000	±5
1907.6	Body	53.78	1.54	53.30	1.52	0.901	1.316	±5
2412.0	Body	52.78	1.90	52.70	1.95	0.152	-2.564	±5
2437.0	Body	52.58	1.95	52.70	1.95	-0.228	0.000	±5
2462.0	Body	52.41	1.98	52.70	1.95	-0.550	1.538	±5

*Liquid Verification was performed on 2013-03-24

Please refer to the following tables.

850 MHz Body				1800 MHz Body		
Frequency (MHz)	e'	e''		Frequency (MHz)	e'	e''
824.0	54.780273	20.616615		1710.0	53.324322	15.809745
824.5	54.783411	20.516126		1711.5	53.281701	15.709256
825.0	54.786544	20.528644		1713.0	53.326413	15.721774
825.5	54.789687	20.541078		1714.5	53.460815	15.734208
826.0	54.792825	20.676140		1716.0	53.686571	15.869270
826.5	54.795963	20.739871		1717.5	53.863158	15.933001
827.0	54.799101	20.654370		1719.0	53.572994	15.847500
827.5	54.802239	20.532506		1720.5	53.437974	15.725636
828.0	54.805376	20.567068		1722.0	53.468581	15.760198
828.5	54.808514	20.524491		1723.5	53.391559	15.717621
829.0	54.811652	20.628646		1725.0	53.639162	15.821776
829.5	54.814790	20.571475		1726.5	53.556505	15.764605
830.0	54.817928	20.449372		1728.0	53.303811	15.642502
830.5	54.821066	20.513760		1729.5	53.463289	15.706890
831.0	54.824204	20.498935		1731.0	53.357530	15.692065
831.5	54.827342	20.706359		1732.5	53.761987	15.899489
832.0	54.830480	20.684023		1734.0	53.765400	15.877153
832.5	54.833618	20.460722		1735.5	53.306054	15.653852
833.0	54.836756	20.394086		1737.0	53.203419	15.587216
833.5	54.839894	20.505553		1738.5	53.475696	15.698683
834.0	54.843032	20.657410		1740.0	53.729923	15.850540
834.5	54.846170	20.550372		1741.5	53.527609	15.743502
835.0	54.849308	20.493831		1743.0	53.383758	15.686961
835.5	54.852446	20.741538		1744.5	53.769776	15.934668
836.0	54.855584	20.748461		1746.0	53.829199	15.941591
836.5	54.858722	20.606268		1747.5	53.467501	15.799398
837.0	54.861860	20.433351		1749.0	53.111923	15.626481
837.5	54.864998	20.469617		1750.5	53.182402	15.662747
838.0	54.868136	20.753900		1752.0	53.738704	15.947030
838.5	54.871274	20.769104		1753.5	53.879887	15.962234
839.0	54.874412	20.691116		1755.0	53.660168	15.884246
839.5	54.877550	20.626074		1756.5	53.524154	15.819204
840.0	54.880688	20.693217		1758.0	53.690471	15.886347
840.5	54.883826	20.738581		1759.5	53.781321	15.931711
841.0	54.886964	20.693709		1761.0	53.591318	15.886839
841.5	54.890102	20.630446		1762.5	53.629542	15.823576
842.0	54.893240	20.806286		1764.0	53.893423	15.999416
842.5	54.896378	20.774799		1765.5	53.876475	15.967929
843.0	54.899516	20.735197		1767.0	53.733094	15.928327
843.5	54.902654	20.690708		1768.5	53.543178	15.883838
844.0	54.905791	20.708366		1770.0	53.780414	15.901496
844.5	54.908929	20.734273		1771.5	53.819029	15.927403
845.0	54.912067	20.643691		1773.0	53.544354	15.836821
845.5	54.915205	20.590077		1774.5	53.496801	15.783207
846.0	54.918343	20.763078		1776.0	53.826548	15.956208
846.5	54.921481	20.824482		1777.5	53.889877	16.017612
847.0	54.924619	20.773341		1779.0	53.865466	15.966471
847.5	54.927757	20.693642		1780.5	53.650905	15.886772
848.0	54.930895	20.783799		1782.0	53.814831	15.976929
848.5	54.934033	20.861883		1783.5	53.951879	16.055013
849.0	54.937171	20.862065		1785.0	53.969474	16.055195

1900 MHz Body			2450 MHz Body		
Frequency (MHz)	e'	e''	Frequency (MHz)	e'	e''
1850.0	54.065508	14.417950	2412	52.782133	14.199011
1851.2	53.997427	14.375367	2413	52.773103	14.206008
1852.4	54.016271	14.376471	2414	52.764091	14.211010
1853.6	53.992854	14.352744	2415	52.755082	14.216007
1854.8	53.895690	14.372227	2416	52.746071	14.221010
1856.0	53.998713	14.408648	2417	52.737068	14.226015
1857.2	53.991884	14.434633	2418	52.728059	14.231010
1858.4	53.973898	14.355849	2419	52.719044	14.236010
1859.6	53.955569	14.350192	2420	52.710036	14.241009
1860.8	53.851360	14.402988	2421	52.701027	14.246007
1862.0	53.879036	14.230191	2422	52.692032	14.251014
1863.2	53.825017	14.242996	2423	52.683001	14.276010
1864.4	53.859769	14.260079	2424	52.675992	14.283013
1865.6	53.866242	14.231114	2425	52.668984	14.290010
1866.8	53.941252	14.221684	2426	52.661976	14.297009
1868.0	54.009696	14.237757	2427	52.654969	14.304010
1869.2	54.018758	14.260183	2428	52.647961	14.311009
1870.4	53.932256	14.311634	2429	52.640953	14.318008
1871.6	53.874636	14.312343	2430	52.633945	14.325015
1872.8	53.913070	14.341333	2431	52.626938	14.332010
1874.0	53.839535	14.349642	2432	52.619934	14.339007
1875.2	53.902698	14.412899	2433	52.612922	14.346007
1876.4	53.805813	14.335680	2434	52.605914	14.353009
1877.6	53.908096	14.415721	2435	52.598906	14.360014
1878.8	53.935883	14.547557	2436	52.591899	14.367009
1880.0	53.818204	14.566512	2437	52.584891	14.374009
1881.2	53.776444	14.563548	2438	52.577883	14.381014
1882.4	53.871986	14.534926	2439	52.570875	14.388013
1883.6	53.837487	14.490949	2440	52.563867	14.395013
1884.8	53.862384	14.513690	2441	52.556865	14.402009
1886.0	53.897595	14.445884	2442	52.549852	14.409008
1887.2	53.878370	14.422050	2443	52.542844	14.416007
1888.4	53.968147	14.456359	2444	52.535836	14.420006
1889.6	53.898638	14.460971	2445	52.528829	14.424009
1890.8	53.944313	14.517800	2446	52.521821	14.428012
1892.0	53.932277	14.313983	2447	52.514813	14.432011
1893.2	53.904729	14.274904	2448	52.507805	14.436010
1894.4	53.877367	14.323986	2449	52.500797	14.440008
1895.6	53.870215	14.657787	2450	52.493794	14.444008
1896.8	53.860116	14.655894	2451	52.486782	14.448009
1898.0	53.860446	14.636454	2452	52.479774	14.452008
1899.2	53.937447	14.636894	2453	52.472766	14.456007
1900.4	53.902363	14.535551	2454	52.465758	14.460008
1901.6	53.905846	14.624897	2455	52.458751	14.464012
1902.8	53.874937	14.584919	2456	52.451743	14.468008
1904.0	53.956648	14.553736	2457	52.444735	14.472008
1905.2	53.868405	14.522257	2458	52.437727	14.476015
1906.4	53.858317	14.447191	2459	52.430721	14.480008
1907.6	53.783997	14.563982	2460	52.423712	14.484013
1908.8	53.868277	14.499410	2461	52.416704	14.488008
1910.0	53.894800	14.463032	2462	52.409696	14.492011

System Accuracy Verification

Prior to the assessment, the system validation kit was used to test whether the system was operating within its specifications of $\pm 10\%$. The validation results are tabulated below. And also the corresponding SAR plot is attached as well in the SAR plots files.

System Verification Setup Block Diagram

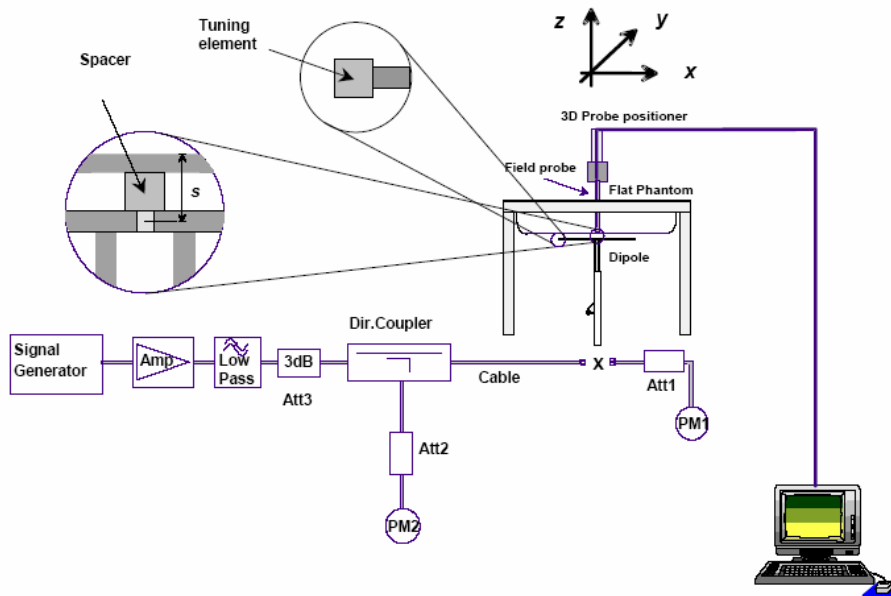

Probe and dipole antenna List and Detail

Manufacturer	Description	Model	Serial Number	Calibration Date	Calibration Due Date
APREL	Probe	ALS-E-020	500-00283	2012-08-09	2013-08-08
APREL	Dipole antenna(835MHz)	ALS-D-835-S-2	180-00558	2011-08-25	2014-08-24
APREL	Dipole antenna(1800MHz)	ALS-D-1800-S-2	200-00659	2011-08-25	2014-08-24
APREL	Dipole antenna(1900MHz)	ALS-D-1900-S-2	210-00710	2011-08-25	2014-08-24
APREL	Dipole antenna(2450MHz)	ALS-D-2450-S-2	220-00758	2011-08-25	2014-08-24

System Accuracy Check Results

Date	Frequency Band	Liquid Type	Measured SAR (W/Kg)		Target Value (W/Kg)	Delta (%)	Tolerance (%)
2013-03-24	835	Body	1g	9.758	9.684	0.764	± 10
	1800	Body	1g	41.322	40.987	0.817	± 10
	1900	Body	1g	40.214	39.769	1.119	± 10
	2450	Body	1g	53.012	52.561	0.858	± 10

*All SAR values are normalized to 1 Watt forward power.

SAR SYSTEM VALIDATION DATA**Test Laboratory: Bay Area Compliance Lab Corp. (Shenzhen)****System Performance Check 835MHz Body Liquid****Dipole 835 MHz; Type: ALS-D-835-S-2; S/N: 180-00558**

Product Data

Device Name : Dipole 835 MHz
Serial No. : 180-00558
Type : Dipole
Model : ALS-D-835-S-2
Frequency Band : 835
Max. Transmit Pwr : 1 W
Drift Time : 3 min(s)
Power Drift-Start : 10.158 W/kg
Power Drift-Finish : 10.011 W/kg
Power Drift (%) : -1.419

Phantom Data

Name : APREL-Uni
Type : Uni-Phantom
Size (mm) : 280 x 280 x 200
Serial No. : System Default
Location : Center
Description : Default
Phantom Data

Tissue Data

Type : Body
Serial No. : 270-02101
Frequency : 835.0 MHz
Last Calib. Date : 24-Mar-2013
Temperature : 20.00 °C
Ambient Temp. : 21.00 °C
Humidity : 56.00 RH%
Epsilon : 54.85 F/m
Sigma : 0.96S/m
Density : 1000.00 kg/cu. m

Probe Data

Name : E-Field
Model : E-020
Type : E-Field Triangle
Serial No. : 500-00283
Last Calib. Date : 09-Aug-2012
Frequency Band : 835
Duty Cycle Factor : 1
Conversion Factor : 6.6
Probe Sensitivity : 1.20 1.20 1.20 $\mu\text{V}/(\text{V}/\text{m})^2$
Compression Point : 95.00 mV
Offset : 1.56 mm

Measurement Data

Crest Factor : 1
Scan Type : Complete
Tissue Temp. : 21.00 °C
Ambient Temp. : 21.00 °C
Area Scan : 7x9x1 : Measurement x=10mm, y=10mm, z=4mm
Zoom Scan : 7x7x7 : Measurement x=5mm, y=5mm, z=5mm

1 gram SAR value : 9.758 W/kg
10 gram SAR value : 5.988 W/kg
Area Scan Peak SAR : 10.998 W/kg
Zoom Scan Peak SAR : 18.014 W/kg

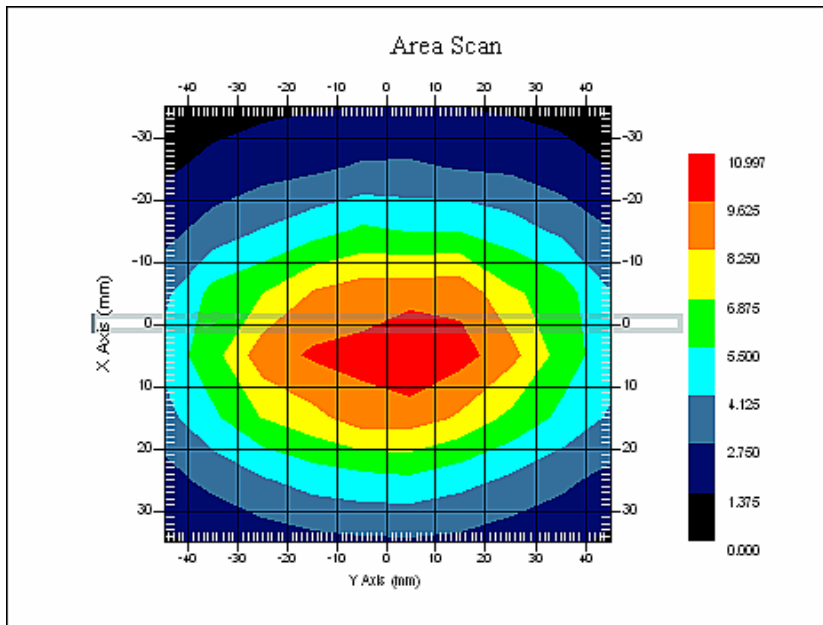

835 MHz System Validation with Body Tissue

Test Laboratory: Bay Area Compliance Lab Corp. (Shenzhen)**System Performance Check 1800 MHz Body Liquid****Dipole 1800 MHz; Type: ALS-D-1800-S-2; S/N: 200-00659**

Product Data

Device Name : Dipole 1800MHz
Serial No. : 200-00659
Type : Dipole
Model : ALS-D-1800-S-2
Frequency Band :1800
Max. Transmit Pwr : 1 W
Drift Time : 3 min(s)
Power Drift-Start : 41.052 W/kg
Power Drift-Finish : 41.674 W/kg
Power Drift (%) : 1.485

Phantom Data

Name : APREL-Uni
Type : Uni-Phantom
Size (mm) : 280 x 280 x 200
Serial No. : System Default
Location : Center
Description : Default

Tissue Data

Type : BODY
Serial No. : 290-02201
Frequency : 1800.00 MHz
Last Calib. Date : 24-Mar-2013
Temperature : 20.00 °C
Ambient Temp. : 21.00 °C
Humidity : 56.00 RH%
Epsilon : 53.79 F/m
Sigma : 1.56 S/m
Density : 1000.00 kg/cu. m

Probe Data

Name : E-Field
Model : E-020
Type : E-Field Triangle
Serial No. : 500-00283
Last Calib. Date : 09-Aug-2012
Frequency Band :1800
Duty Cycle Factor : 1
Conversion Factor : 4.8
Probe Sensitivity : 1.20 1.20 1.20 $\mu\text{V}/(\text{V}/\text{m})^2$
Compression Point : 95.00 mV
Offset : 1.56 mm

Measurement Data

Crest Factor : 1
Scan Type : Complete
Tissue Temp. : 20.00 °C
Ambient Temp. : 21.00 °C
Area Scan : 7x9x1 : Measurement x=10mm, y=10mm, z=4mm
Zoom Scan : 7x7x7 : Measurement x=5mm, y=5mm, z=5mm

1 gram SAR value : 41.322 W/kg
10 gram SAR value : 21.928 W/kg
Area Scan Peak SAR : 42.335 W/kg
Zoom Scan Peak SAR : 90.894 W/kg

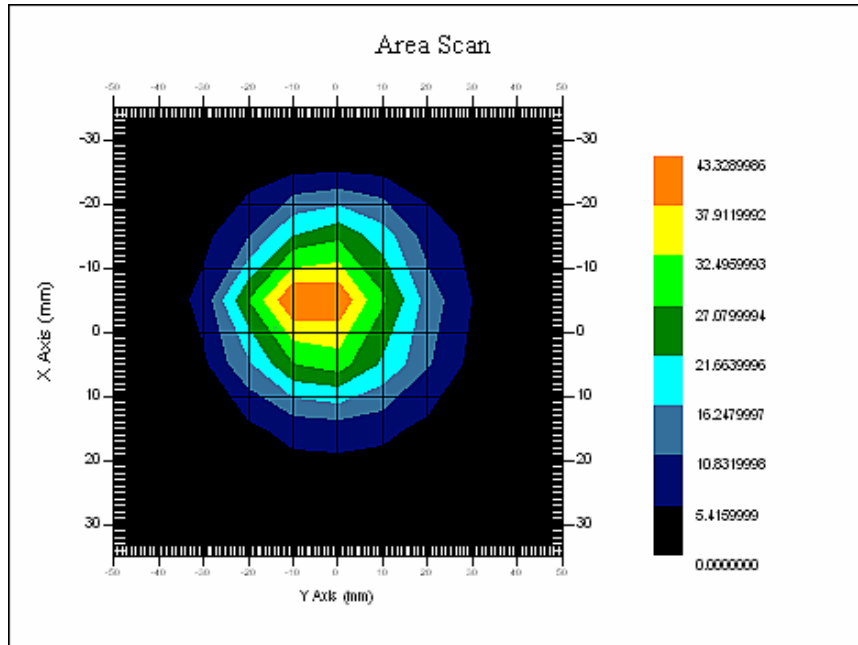

1800 MHz System Validation with Body Tissue

Test Laboratory: Bay Area Compliance Lab Corp. (Shenzhen)**System Performance Check 1900 MHz Body Liquid****Dipole 1900 MHz; Type: ALS-D-1900-S-2; S/N: 210-00710**

Product Data

Device Name : Dipole 1900MHz
Serial No. : 210-00710
Type : Dipole
Model : ALS-D-1900-S-2
Frequency Band : 1900
Max. Transmit Pwr : 1 W
Drift Time : 3 min(s)
Power Drift-Start : 41.084 W/kg
Power Drift-Finish : 40.428 W/kg
Power Drift (%) : -1.537

Phantom Data

Name : APREL-Uni
Type : Uni-Phantom
Size (mm) : 280 x 280 x 200
Serial No. : System Default
Location : Center
Description : Default

Tissue Data

Type : Body
Serial No. : 295-02102
Frequency : 1900.00 MHz
Last Calib. Date : 24-Mar-2013
Temperature : 20.00 °C
Ambient Temp. : 21.00 °C
Humidity : 56.00 RH%
Epsilon : 53.90 F/m
Sigma : 1.54 S/m
Density : 1000.00 kg/cu. m

Probe Data

Name : E-Field
Model : E-020
Type : E-Field Triangle
Serial No. : 500-00283
Last Calib. Date : 09-Aug-2012
Frequency Band : 1900
Duty Cycle Factor : 1
Conversion Factor : 5.0
Probe Sensitivity : 1.20 1.20 1.20 $\mu\text{V}/(\text{V}/\text{m})^2$
Compression Point : 95.00 mV
Offset : 1.56 mm

Measurement Data

Crest Factor : 1
Scan Type : Complete
Tissue Temp. : 20.00 °C
Ambient Temp. : 21.00 °C
Area Scan : 7x9x1 : Measurement x=10mm, y=10mm, z=4mm
Zoom Scan : 7x7x7 : Measurement x=5mm, y=5mm, z=5mm

1 gram SAR value : 40.214 W/kg
10 gram SAR value : 20.879 W/kg
Area Scan Peak SAR : 42.038 W/kg
Zoom Scan Peak SAR : 99.848 W/kg

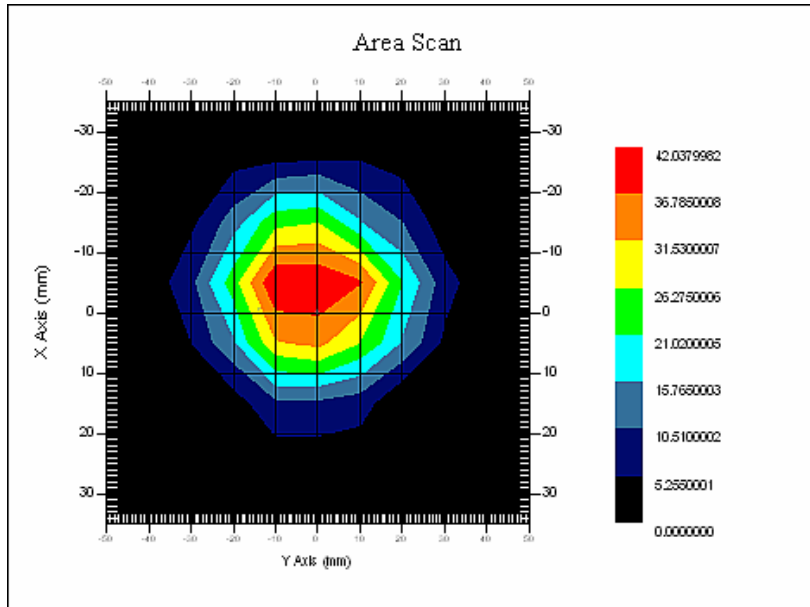

1900 MHz System Validation with Body Tissue

Test Laboratory: Bay Area Compliance Lab Corp. (Shenzhen)**System Performance Check 2450 MHz Body Liquid****Dipole 2450 MHz; Type: ALS-D-2450-S-2; S/N: 220-00758**

Product Data

Device Name : Dipole 2450MHz
Serial No. : 220-00758
Type : Dipole
Model : ALS-D-2450-S-2
Frequency Band : 2450
Max. Transmit Pwr : 1 W
Drift Time : 3 min(s)
Power Drift-Start : 50.859 W/kg
Power Drift-Finish : 50.128 W/kg
Power Drift (%) : -1.378

Phantom Data

Name : APREL-Uni
Type : Uni-Phantom
Size (mm) : 280 x 280 x 200
Serial No. : System Default
Location : Center
Description : Default

Tissue Data

Type : BODY
Serial No. : 290-01109
Frequency : 2450.00 MHz
Last Calib. Date : 24-Mar-2013
Temperature : 20.00 °C
Ambient Temp. : 21.00 °C
Humidity : 50.00 RH%
Epsilon : 52.49 F/m
Sigma : 1.97 S/m
Density : 1000.00 kg/cu. M

Probe Data

Name : E-Field
Model : E-020
Type : E-Field Triangle
Serial No. : 500-00283
Last Calib. Date : 09-Aug-2012
Frequency Band : 2450
Duty Cycle Factor : 1
Conversion Factor : 4.3
Probe Sensitivity : 1.20 1.20 1.20 $\mu\text{V}/(\text{V}/\text{m})^2$
Compression Point : 95.00 mV
Offset : 1.56 mm

Measurement Data

Crest Factor : 1
Scan Type : Complete
Tissue Temp. : 20.00 °C
Ambient Temp. : 20.00 °C
Area Scan : 8x9x1 : Measurement x=10mm, y=10mm, z=4mm
Zoom Scan : 7x7x7 : Measurement x=5mm, y=5mm, z=5mm

1 gram SAR value : 53.012 W/kg
10 gram SAR value : 24.524 W/kg
Area Scan Peak SAR : 68.686 W/kg
Zoom Scan Peak SAR : 105.981 W/kg

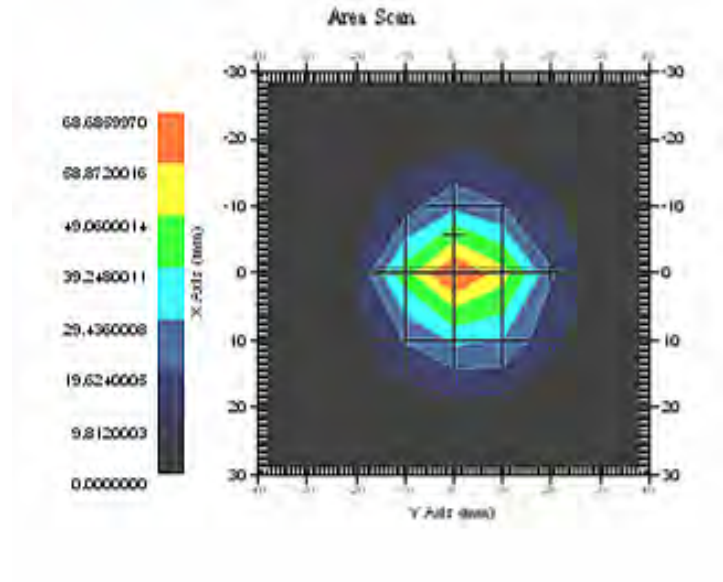

2450 MHz System Validation with Body Tissue

EUT TEST STRATEGY AND METHODOLOGY

Test Positions for Device Operating Next to a Person’s Ear

This category includes most wireless handsets with fixed, retractable or internal antennas located toward the top half of the device, with or without a foldout, sliding or similar keypad cover. The handset should have its earpiece located within the upper ¼ of the device, either along the centerline or off-centered, as perceived by its users. This type of handset should be positioned in a normal operating position with the “test device reference point” located along the “vertical centerline” on the front of the device aligned to the “ear reference point”. The “test device reference point” should be located at the same level as the center of the earpiece region. The “vertical centerline” should bisect the front surface of the handset at its top and bottom edges. A “ear reference point” is located on the outer surface of the head phantom on each ear spacer. It is located 1.5 cm above the center of the ear canal entrance in the “phantom reference plane” defined by the three lines joining the center of each “ear reference point” (left and right) and the tip of the mouth.

A handset should be initially positioned with the earpiece region pressed against the ear spacer of a head phantom. For the SCC-34/SC-2 head phantom, the device should be positioned parallel to the “N-F” line defined along the base of the ear spacer that contains the “ear reference point”. For interim head phantoms, the device should be positioned parallel to the cheek for maximum RF energy coupling. The “test device reference point” is aligned to the “ear reference point” on the head phantom and the “vertical centerline” is aligned to the “phantom reference plane”. This is called the “initial ear position”. While maintaining these three alignments, the body of the handset is gradually adjusted to each of the following positions for evaluating SAR:

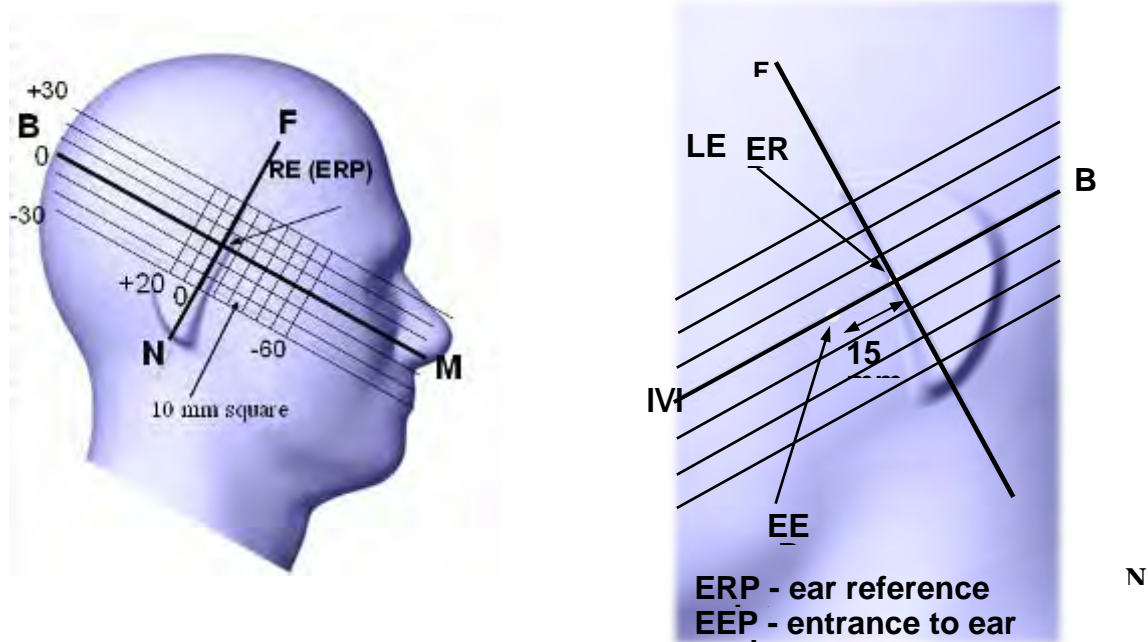

Cheek/Touch Position

The device is brought toward the mouth of the head phantom by pivoting against the “ear reference point” or along the “N-F” line for the SCC-34/SC-2 head phantom.

This test position is established:

- When any point on the display, keypad or mouthpiece portions of the handset is in contact with the phantom.
- (or) When any portion of a foldout, sliding or similar keypad cover opened to its intended self-adjusting normal use position is in contact with the cheek or mouth of the phantom.

For existing head phantoms – when the handset loses contact with the phantom at the pivoting point, rotation should continue until the device touches the cheek of the phantom or breaks its last contact from the ear spacer.

Cheek /Touch Position

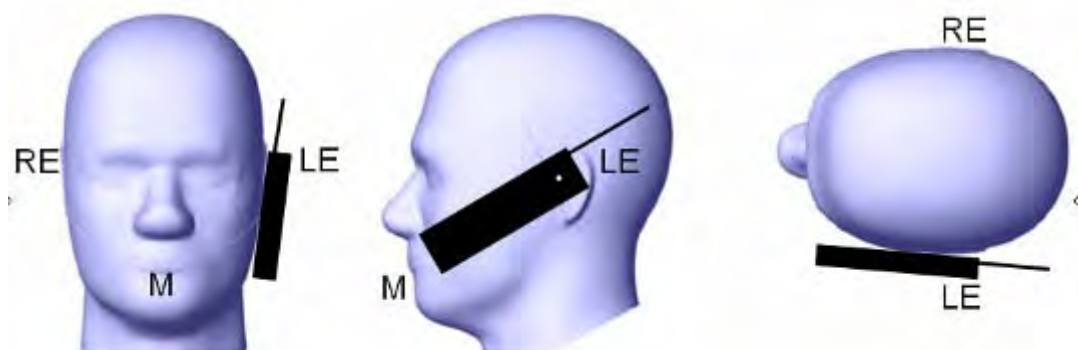

Ear/Tilt Position

With the handset aligned in the “Cheek/Touch Position”:

1) If the earpiece of the handset is not in full contact with the phantom’s ear spacer (in the “Cheek/Touch position”) and the peak SAR location for the “Cheek/Touch” position is located at the ear spacer region or corresponds to the earpiece region of the handset, the device should be returned to the “initial ear position” by rotating it away from the mouth until the earpiece is in full contact with the ear spacer.

2) (otherwise) The handset should be moved (translated) away from the cheek perpendicular to the line passes through both “ear reference points” (note: one of these ear reference points may not physically exist on a split head model) for approximate 2-3 cm. While it is in this position, the device handset is tilted away from the mouth with respect to the “test device reference point” until the inside angle between the vertical centerline on the front surface of the phone and the horizontal line passing through the ear reference point is by 15° to 80° . After the tilt, it is then moved (translated) back toward the head perpendicular to the line passes through both “ear reference points” until the device touches the phantom or the ear spacer. If the antenna touches the head first, the positioning process should be repeated with a tilt angle less than 15° so that the device and its antenna would touch the phantom simultaneously. This test position may require a device holder or positioner to achieve the translation and tilting with acceptable positioning repeatability.

If a device is also designed to transmit with its keypad cover closed for operating in the head position, such positions should also be considered in the SAR evaluation. The device should be tested on the left and right side of the head phantom in the “Cheek/Touch” and “Ear/Tilt” positions. When applicable, each configuration should be tested with the antenna in its fully extended and fully retracted positions. These test configurations should be tested at the high, middle and low frequency channels of each operating mode; for example, AMPS, CDMA, and TDMA. If the SAR measured at the middle channel for each test configuration (left, right, Cheek/Touch, Tile/Ear, extended and retracted) is at least 2.0 dB lower than the SAR limit, testing at the high and low channels is optional for such test configuration(s). If the transmission band of the test device is less than 10 MHz, testing at the high and low frequency channels is optional.

Ear /Tilt 15° Position

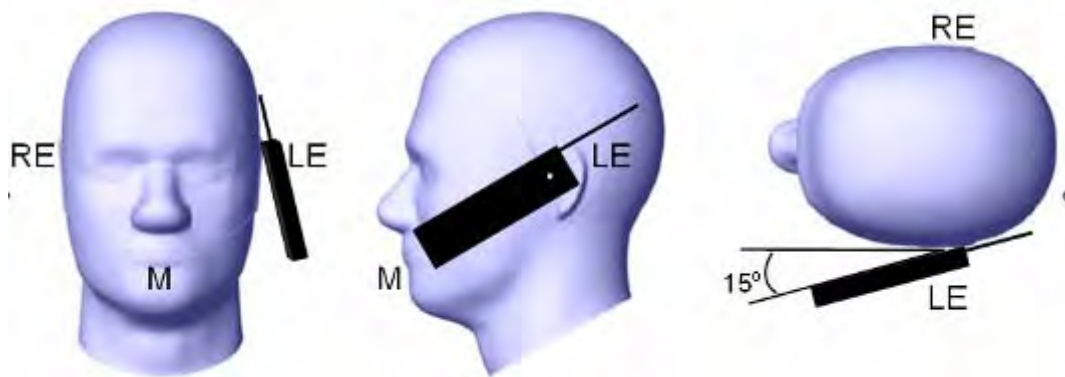

Test positions for body-worn and other configurations

Body-worn operating configurations should be tested with the belt-clips and holsters attached to the device and positioned against a flat phantom in normal use configurations. Devices with a headset output should be tested with a headset connected to the device. When multiple accessories that do not contain metallic components are supplied with the device, the device may be tested with only the accessory that dictates the closest spacing to the body. When multiple accessories that contain metallic components are supplied with the device, the device must be tested with each accessory that contains a unique metallic component. If multiple accessories share an identical metallic component (e.g., the same metallic belt-clip used with different holsters with no other metallic components), only the accessory that dictates the closest spacing to the body must be tested.

Body-worn accessories may not always be supplied or available as options for some devices that are intended to be authorized for body-worn use. A separation distance of 1.5 cm between the back of the device and a flat phantom is recommended for testing body-worn SAR compliance under such circumstances. Other separation distances may be used, but they should not exceed 2.5 cm. In these cases, the device may use body-worn accessories that provide a separation distance greater than that tested for the device provided however that the accessory contains no metallic components.

SAR Evaluation Procedure

The evaluation was performed with the following procedure:

Step 1: Measurement of the SAR value at a fixed location above the ear point or central position was used as a reference value for assessing the power drop. The SAR at this point is measured at the start of the test and then again at the end of the testing.

Step 2: The SAR distribution at the exposed side of the head was measured at a distance of 4 mm from the inner surface of the shell. The area covered the entire dimension of the head or EUT and the horizontal grid spacing was 10 mm x 10 mm. Based on these data, the area of the maximum absorption was determined by spline interpolation. The first Area Scan covers the entire dimension of the EUT to ensure that the hotspot was correctly identified.

Step 3: Around this point, a volume of 35 mm x 35 mm x 35 mm was assessed by measuring 7x 7 x 7 points. On the basis of this data set, the spatial peak SAR value was evaluated under the following procedure:

- 1) The data at the surface were extrapolated, since the center of the dipoles is 1.2 mm away from the tip of the probe and the distance between the surface and the lowest measuring point is 1.3 mm. The extrapolation was based on a least square algorithm. A polynomial of the fourth order was calculated through the points in z-axes. This polynomial was then used to evaluate the points between the surface and the probe tip.
- 2) The maximum interpolated value was searched with a straightforward algorithm. Around this maximum the SAR values averaged over the spatial volumes (1 g or 10 g) were computed by the 3D-Spline interpolation algorithm. The 3D-Spline is composed of three one dimensional splines with the "Not a knot"-condition (in x, y and z-directions). The volume was integrated with the trapezoidal-algorithm. One thousand points (10 x 10 x 10) were interpolated to calculate the averages.

All neighboring volumes were evaluated until no neighboring volume with a higher average value was found.

Step 4: Re-measurement of the SAR value at the same location as in Step 1. If the value changed by more than 5%, the evaluation was repeated.

CONDUCTED OUTPUT POWER MEASUREMENT

Provision Applicable

The measured peak output power should be greater and within 5% than EMI measurement.

Test Procedure

The RF output of the transmitter was connected to the input of the EMI Test Receiver through sufficient attenuation.

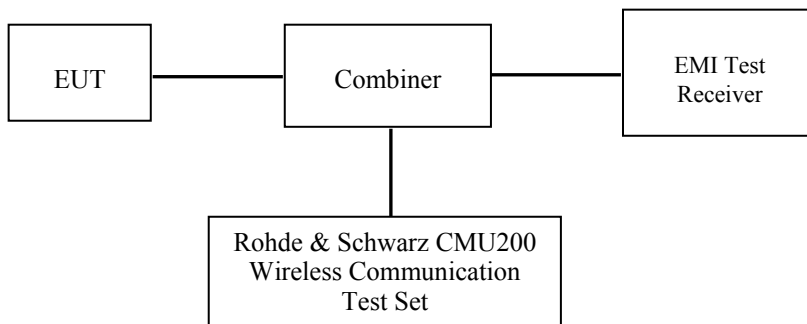

3G

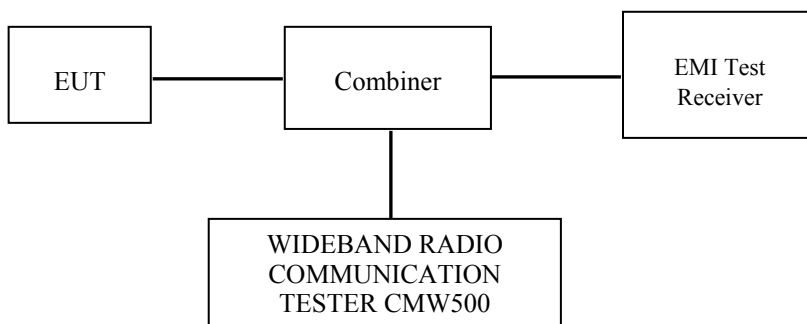

LTE

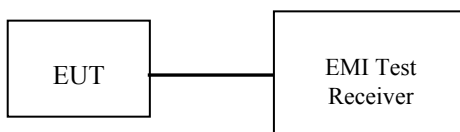

WiFi

Test Results:

WCDMA-Release 99:

The following tests were conducted according to the test requirements outlines in section 5.2 of the 3GPP TS34.121-1 specification. The EUT has a nominal maximum output power of 24dBm (+1.7/-3.7).

WCDMA General Settings	Loopback Mode	Test Mode 1
	Rel99 RMC	12.2kbps RMC
	Power Control Algorithm	Algorithm2
	β_c / β_d	8/15

Results (12.2kbps RMC)

Band	Frequency (MHz)	Channel NO.	Conducted Output Power	
			(dBm)	(Watt)
WCDMA 850	824.4	4 122	23.07	0.203
	836.6	4 175	23.04	0.201
	848.6	4 233	23.16	0.207
WCDMA 1900	1850.4	9 252	22.78	0.190
	1880.0	9 400	22.57	0.181
	1909.6	9 548	22.66	0.185

WCDMA HSDPA

The following tests were conducted according to the test requirements outlines in section 5.2 of the 3GPP TS34.121-1 specification.

	Mode	HSDPA	HSDPA	HSDPA	HSDPA
	Subset	1	2	3	4
WCDMA General Settings	Loopback Mode	Test Mode 1			
	Rel99 RMC	12.2kbps RMC			
	HSDPA FRC	H-Set1			
	Power Control Algorithm	Algorithm2			
	β_c	2/15	12/15	15/15	15/15
	β_d	15/15	15/15	8/15	4/15
	β_d (SF)	64			
	β_c/β_d	2/15	12/15	15/8	15/4
	β_{hs}	4/15	24/15	30/15	30/15
	MPR(dB)	0	0	0.5	0.5
HSDPA Specific Settings	D_{ACK}	8			
	D_{NAK}	8			
	D_{CQI}	8			
	Ack-Nack repetition factor	3			
	CQI Feedback	4ms			
	CQI Repetition Factor	2			
	$A_{hs} = \beta_{hs}/\beta_c$	30/15			

Results (HSDPA)

Band	Frequency (MHz)	Channel NO.	Conducted Output Power			
			Subset 1	Subset 2	Subset 3	Subset 4
WCDMA 850	824.4	4 122	23.01	22.99	23.02	22.97
	836.6	4 175	22.98	23.00	23.03	22.99
	848.6	4 233	23.03	23.02	23.04	23.04
WCDMA 1900	1850.4	9 252	22.69	22.72	22.70	22.71
	1880.0	9 400	22.50	22.49	22.53	22.51
	1909.6	9 548	22.60	22.58	22.61	22.60

WCDMA HSUPA

The following tests were conducted according to the test requirements outlines in section 5.2 of the 3GPP TS34.121-1 specification.

	Mode	HSUPA	HSUPA	HSUPA	HSUPA	HSUPA
	Subset	1	2	3	4	5
WCDMA General Settings	Loopback Mode	Test Mode 1				
	Rel99 RMC	12.2kbps RMC				
	HSDPA FRC	H-Set1				
	HSUPA Test	HSUPA Loopback				
	Power Control Algorithm	Algorithm2				
	β_c	11/15	6/15	15/15	2/15	15/15
	β_d	15/15	15/15	9/15	15/15	0
	β_{ec}	209/225	12/15	30/15	2/15	5/15
	β_c/β_d	11/15	6/15	15/9	2/15	-
	β_{hs}	22/15	12/15	30/15	4/15	5/15
	CM(dB)	1.0	3.0	2.0	3.0	1.0
MPR(dB)	0	2	1	2	0	
HSDPA Specific Settings	DACK	8				
	DNAK	8				
	DCQI	8				
	Ack-Nack repetition factor	3				
	CQI Feedback	4ms				
	CQI Repetition Factor	2				
	$A_{hs} = \beta_{hs}/\beta_c$	30/15				
HSUPA Specific Settings	DE-DPCCH	6	8	8	5	7
	DHARQ	0	0	0	0	0
	AG Index	20	12	15	17	21
	ETFCI	75	67	92	71	81
	Associated Max UL Data Rate kbps	242.1	174.9	482.8	205.8	308.9
	Reference E_FCIs	E-TFCI 11 E E-TFCI PO 4 E-TFCI 67 E-TFCI PO 18 E-TFCI 71 E-TFCI PO23 E-TFCI 75 E-TFCI PO26 E-TFCI 81 E-TFCI PO 27	E-TFCI 11 E-TFCI PO4 E-TFCI 92 E-TFCI PO 18	E-TFCI 11 E E-TFCI PO 4 E-TFCI 67 E-TFCI PO 18 E-TFCI 71 E-TFCI PO23 E-TFCI 75 E-TFCI PO26 E-TFCI 81 E-TFCI PO 27		

Results (HSUPA)

Band	Frequency (MHz)	Channel NO.	Conducted Output Power				
			Subset 1	Subset 2	Subset 3	Subset 4	Subset 5
WCDMA 850	824.2	4 133	22.95	22.97	22.94	22.90	22.96
	836.6	4 175	22.97	23.00	22.96	23.01	23.00
	848.8	4 232	23.02	23.00	23.03	23.02	23.01
WCDMA 1900	1850.2	9 263	22.65	22.63	22.66	22.63	22.64
	1880.0	9 400	22.46	22.48	22.43	22.45	22.46
	1909.8	9 537	22.56	22.52	22.53	22.56	22.54

Note:

1. The default test configuration is to measure SAR with an established radio link between the EUT and a communication test set using a 12.2 kbps RMC (reference measurement Channel) Configured in Test Loop Model 1.
2. KDB 941225 D01-Body SAR is not required for HSDPA when the maximum average output of each RF channel with HSDPA active is less than $\frac{1}{4}$ dB higher than measured without HSDPA using 12.2kbps RMC or the maximum SAR for 12.2kbps RMC is $< 75\%$ of SAR limit.
3. KDB 941225 D01-Body SAR is not required for HSUPA when the maximum average output of each RF channel with HSUPA active is less than $\frac{1}{4}$ dB higher than measured without HSUPA using 12.2kbps RMC and the maximum SAR for 12.2kbps RMC is $< 75\%$ of SAR limit.

WiFi

Band	Frequency (MHz)	Conducted Output Power	
		(dBm)	(Watt)
802.11b	2412	17.23	0.053
	2437	17.16	0.052
	2462	17.83	0.061
802.11g	2412	19.73	0.094
	2437	19.74	0.094
	2462	19.88	0.097
802.11n-20	2412	19.72	0.094
	2437	19.74	0.094
	2462	19.84	0.096

Note:

1. The output power was tested under data rate 1Mbps for 802.11b, 6Mbps for 802.11g, 6.5Mbps for 802.11n-20.
2. The maximum output power of the 802.11g mode is more than 2 dB higher than 802.11b mode measured in the same frequency band, according to IEEE 1528, 802.11b mode SAR is not required.
3. KDB248227-SAR is not required for 802.11n channels when the maximum average output power is less than 1/4 dB higher than that measured on the corresponding 802.11g channels.

LTE Band 4:

Bandwidth (MHz)	Frequency (MHz)	Resource Block / RB offset	Average Output Power (dBm) QPSK	Peak to Average Ratio (dB)	Target MPR (dB)	Average Output Power (dBm) 16-QAM	Peak to Average Ratio (dB)	Target MPR (dB)
1.4	1710.7	1/0	22.65	4.32	0	22.15	5.12	1
		1/3	22.68	4.24	0	22.21	5.08	1
		1/5	22.71	4.30	0	22.20	5.15	1
		3/0	22.80	4.81	0	/	/	/
		3/3	22.87	4.78	0	/	/	/
		6/0	21.81	4.96	1	20.78	6.42	2
	1732.5	1/0	22.87	3.51	0	22.06	5.03	1
		1/3	22.84	3.47	0	22.06	5.02	1
		1/5	22.89	3.51	0	22.03	5.10	1
		3/0	22.78	3.79	0	/	/	/
		3/3	22.76	3.81	0	/	/	/
		6/0	21.86	5.59	1	22.00	5.97	2
	1754.3	1/0	22.91	3.79	0	22.04	5.17	1
		1/3	22.79	3.71	0	22.05	5.11	1
		1/5	22.80	3.74	0	22.00	5.21	1
		3/0	22.78	4.07	0	/	/	/
		3/3	22.69	4.08	0	/	/	/
		6/0	21.77	5.13	1	20.79	6.62	2
3.0	1711.5	1/0	23.00	4.24	0	22.17	5.17	1
		1/8	23.05	4.13	0	22.22	5.03	1
		1/14	23.07	4.14	0	22.18	5.18	1
		6/0	21.90	5.24	1	/	/	/
		6/9	21.87	5.25	1	/	/	/
		15/0	21.73	5.06	1	20.92	6.92	2
	1732.5	1/0	22.95	3.26	0	22.09	5.07	1
		1/8	22.81	3.42	0	22.04	4.98	1
		1/14	22.70	3.42	0	21.88	5.15	1
		6/0	21.80	4.54	1	/	/	/
		6/9	21.65	4.61	1	/	/	/
		15/0	21.86	5.76	1	21.09	7.35	2
	1753.5	1/0	22.92	3.82	0	22.08	5.20	1
		1/8	22.92	3.61	0	22.11	5.05	1
		1/14	22.86	3.63	0	21.98	5.18	1
		6/0	21.79	4.93	1	/	/	/
		6/9	21.75	4.83	1	/	/	/
		15/0	21.80	5.34	1	20.94	7.23	2

5.0	1712.5	1/ 0	22.96	3.84	0	22.10	6.49	1
		1/ 13	22.98	3.71	0	22.15	6.31	1
		1/ 24	22.92	3.82	0	22.07	6.45	1
		15/ 0	21.91	6.41	1	/	/	/
		15/ 10	21.88	6.40	1	/	/	/
		25/ 0	21.68	6.33	1	20.95	7.53	2
	1732.5	1/ 0	22.92	4.75	0	22.08	6.27	1
		1/ 13	22.86	4.69	0	22.03	6.17	1
		1/ 24	22.76	4.89	0	21.82	6.45	1
		15/ 0	21.84	6.65	1	/	/	/
		15/ 10	21.70	6.75	1	/	/	/
		25/ 0	21.89	6.23	1	21.15	7.67	2
	1752.5	1/ 0	22.81	4.59	0	22.04	6.54	1
		1/ 13	22.90	4.55	0	22.01	6.33	1
		1/ 24	22.80	4.82	0	21.90	6.50	1
		15/ 0	21.82	6.75	1	/	/	/
		15/ 10	21.79	6.61	1	/	/	/
		25/ 0	21.73	6.39	1	21.01	7.62	2
10.0	1715.0	1/ 0	23.03	4.97	0	22.22	5.21	1
		1/ 25	23.09	4.89	0	22.25	5.06	1
		1/ 49	23.12	5.45	0	22.32	5.12	1
		25/ 0	21.92	6.33	1	/	/	/
		25/ 25	22.08	6.24	1	/	/	/
		50/ 0	21.76	6.33	1	21.06	7.09	2
	1732.5	1/ 0	23.08	5.21	0	22.23	5.01	1
		1/ 25	22.90	5.25	0	22.10	5.04	1
		1/ 49	22.80	5.62	0	22.02	5.24	1
		25/ 0	21.87	6.14	1	/	/	/
		25/ 25	21.74	6.28	1	/	/	/
		50/ 0	21.92	6.50	1	21.36	7.15	2
	1750.0	1/ 0	22.86	5.71	0	22.02	5.30	1
		1/ 25	22.90	5.42	0	22.12	5.15	1
		1/ 49	22.85	5.50	0	22.06	5.20	1
		25/ 0	21.83	6.47	1	/	/	/
		25/ 25	21.86	6.34	1	/	/	/
		50/ 0	21.77	6.53	1	20.99	7.17	2

15.0	1717.5	1/ 0	23.05	5.52	0	22.22	5.24	1
		1/ 38	23.06	5.51	0	22.24	5.03	1
		1/ 74	23.05	5.27	0	22.20	5.00	1
		36/ 0	22.08	6.61	1	/	/	/
		36/ 39	22.15	6.32	1	/	/	/
		75/ 0	22.01	6.72	1	21.23	7.37	2
	1732.5	1/ 0	23.01	5.29	0	22.21	5.03	1
		1/ 38	22.81	5.44	0	22.10	5.02	1
		1/ 74	22.66	5.71	0	21.89	5.26	1
		36/ 0	22.00	6.35	1	/	/	/
		36/ 39	21.81	6.53	1	/	/	/
		75/ 0	21.88	6.81	1	20.97	7.61	2
	1747.5	1/ 0	22.87	5.61	0	22.04	5.20	1
		1/ 38	22.87	5.63	0	22.10	5.18	1
		1/ 74	22.82	5.54	0	22.14	5.21	1
		36/ 0	21.82	6.76	1	/	/	/
		36/ 39	21.92	6.55	1	/	/	/
		75/ 0	21.81	6.69	1	21.00	7.40	2
20.0	1732.5	1/ 0	23.08	5.30	0	22.29	5.02	1
		1/ 50	22.83	5.26	0	22.12	5.00	1
		1/ 99	22.85	5.68	0	22.07	5.29	1
		50/ 0	22.02	6.08	1	/	/	/
		50/ 50	21.79	6.41	1	/	/	/
		100/ 0	21.99	6.43	1	22.04	6.27	2

Note:

1. For LTE bands that do not support at least three non-overlapping channels in certain channel bandwidths, test the available non-overlapping channels instead. When a device supports overlapping channel assignment in a channel bandwidth configuration, the middle channel of the group of overlapping channels should be selected for testing; therefore, the requirement for H, M and L channels may not fully apply.
2. MPR is permanently implemented for this device by the manufacturer. The specific manufacturer target MPR is indicated alongside the SAR results. MPR is enabled for this device, according to 3GPP TS36.101 section 6.2.3-6.2.5 under Table 6.2.3-1.
3. A-MPR (Additional MPR) has been disabled for all SAR test by setting NS=01 on the base station simulator.

SAR MEASUREMENT RESULTS

This page summarizes the results of the performed dosimetric evaluation.

SAR Test Data

Environmental Conditions

Temperature:	21-22° C
Relative Humidity:	50-53%
ATM Pressure:	1001-1002 mbar

* Testing was performed by Sandy Wang on 2013-03-24 to 2013-03-25

WCDMA850

EUT Position	Frequency (MHz)		Test Mode	Antenna Type	Phantom Type	Power Drift (%)	FCC 1g SAR (W/Kg)	
	Channel	MHz					Measurement	Limit
Body-Front (10mm)	4122(Low)	826.4	WCDMA850	Integral	Universal	/	/	1.6
	4183(Middle)	836.6	WCDMA850	Integral	Universal	/	/	1.6
	4233(High)	846.6	WCDMA850	Integral	Universal	-1.427	0.397	1.6
Body-Back (10mm)	4122(Low)	826.4	WCDMA850	Integral	Universal	/	/	1.6
	4183(Middle)	836.6	WCDMA850	Integral	Universal	/	/	1.6
	4233(High)	846.6	WCDMA850	Integral	Universal	-1.681	0.492	1.6
Body-Top (10mm)	4122(Low)	826.4	WCDMA850	Integral	Universal	/	/	1.6
	4183(Middle)	836.6	WCDMA850	Integral	Universal	/	/	1.6
	4233(High)	846.6	WCDMA850	Integral	Universal	1.486	0.262	1.6
Body-Bottom (10mm)	4122(Low)	826.4	WCDMA850	Integral	Universal	/	/	1.6
	4183(Middle)	836.6	WCDMA850	Integral	Universal	/	/	1.6
	4233(High)	846.6	WCDMA850	Integral	Universal	-2.085	0.158	1.6
Body-Left (10mm)	4122(Low)	826.4	WCDMA850	Integral	Universal	/	/	1.6
	4183(Middle)	836.6	WCDMA850	Integral	Universal	/	/	1.6
	4233(High)	846.6	WCDMA850	Integral	Universal	1.592	0.065	1.6

WCDMA1900

EUT Position	Frequency (MHz)		Test Mode	Antenna Type	Phantom Type	Power Drift (%)	FCC 1g SAR (W/Kg)	
	Channel	MHz					Measurement	Limit
Body-Front (10mm)	9252(Low)	1852.4	WCDMA1900	Integral	Universal	-1.078	1.202	1.6
	9400(Middle)	1880.0	WCDMA1900	Integral	Universal	1.883	1.152	1.6
	9548(High)	1907.6	WCDMA1900	Integral	Universal	2.108	0.797	1.6
Body-Back (10mm)	9252(Low)	1852.4	WCDMA1900	Integral	Universal	-1.207	1.343	1.6
	9400(Middle)	1880.0	WCDMA1900	Integral	Universal	-1.353	1.223	1.6
	9548(High)	1907.6	WCDMA1900	Integral	Universal	-0.895	0.620	1.6
Body-Top (10mm)	9252(Low)	1852.4	WCDMA1900	Integral	Universal	-1.897	0.334	1.6
	9400(Middle)	1880.0	WCDMA1900	Integral	Universal	/	/	1.6
	9548(High)	1907.6	WCDMA1900	Integral	Universal	/	/	1.6
Body-Bottom (10mm)	9252(Low)	1852.4	WCDMA1900	Integral	Universal	2.357	0.240	1.6
	9400(Middle)	1880.0	WCDMA1900	Integral	Universal	/	/	1.6
	9548(High)	1907.6	WCDMA1900	Integral	Universal	/	/	1.6
Body-Left (10mm)	9252(Low)	1852.4	WCDMA1900	Integral	Universal	1.328	0.791	1.6
	9400(Middle)	1880.0	WCDMA1900	Integral	Universal	/	/	1.6
	9548(High)	1907.6	WCDMA1900	Integral	Universal	/	/	1.6

Note:

1. When the 1-g SAR is $\leq 0.8\text{W/kg}$, testing for other channels are optional.
2. The default test configuration is to measure SAR with an established radio link between the EUT and a communication test set using a 12.2 kbps RMC (reference measurement Channel) Configured in Test Loop Mode.
3. KDB 941225 D01-Body SAR is not required for HSDPA when the maximum average output of each RF channel with HSDPA active is less than $\frac{1}{4}$ dB higher than measured without HSDPA using 12.2kbps RMC or the maximum SAR for 12.2kbps RMC is $< 75\%$ of SAR limit.
4. KDB 941225 D01-Body SAR is not required for HSUPA when the maximum average output of each RF channel with HSUPA active is less than $\frac{1}{4}$ dB higher than measured without HSUPA using 12.2kbps RMC and the maximum SAR for 12.2kbps RMC is $< 75\%$ of SAR limit.

LTE Band 4 (1 RB):

EUT Position	Frequency (MHz)	Test Mode	Resource Block / RB offset	Antenna Type	Phantom Type	Power Drift (%)	FCC 1g SAR (W/Kg)	
							Measurement	Limit
Body-Front (10mm)	1732.5	LTE Band 4	1/0	Integral	Universal	2.498	1.074	1.6
Body-Back (10mm)	1732.5	LTE Band 4	1/0	Integral	Universal	1.524	1.193	1.6
Body-Top (10mm)	1732.5	LTE Band 4	1/0	Integral	Universal	1.859	0.236	1.6
Body-Bottom (10mm)	1732.5	LTE Band 4	1/0	Integral	Universal	-1.502	0.168	1.6
Body-Left (10mm)	1732.5	LTE Band 4	1/0	Integral	Universal	1.588	0.623	1.6

LTE Band 4 (50 RB):

EUT Position	Frequency (MHz)	Test Mode	Resource Block / RB offset	Antenna Type	Phantom Type	Power Drift (%)	FCC 1g SAR (W/Kg)	
							Measurement	Limit
Body-Front (10mm)	1732.5	LTE Band 4	50/0	Integral	Universal	-2.285	0.771	1.6
Body-Back (10mm)	1732.5	LTE Band 4	50/0	Integral	Universal	3.214	1.024	1.6
Body-Top (10mm)	1732.5	LTE Band 4	50/0	Integral	Universal	1.793	0.179	1.6
Body-Bottom (10mm)	1732.5	LTE Band 4	50/0	Integral	Universal	-1.472	0.121	1.6
Body-Left (10mm)	1732.5	LTE Band 4	50/0	Integral	Universal	-0.669	0.699	1.6

LTE Band 4 (100 RB):

EUT Position	Frequency (MHz)	Test Mode	Resource Block / RB offset	Antenna Type	Phantom Type	Power Drift (%)	FCC 1g SAR (W/Kg)	
							Measurement	Limit
Body-Front (10mm)	1732.5	LTE Band 4	100/0	Integral	Universal	-0.356	1.126	1.6
Body-Back (10mm)	1732.5	LTE Band 4	100/0	Integral	Universal	-3.392	0.837	1.6

Note:

1. When the reported SAR is ≤ 0.8 W/kg, testing of the remaining RB offset configurations and required test channels is not required for 1 RB or 50% RB allocation.
2. When the reported SAR of a required test channel is > 1.45 W/kg, SAR is required for all three RB offset configurations for that required test channel.
3. For QPSK with 100% RB allocation, SAR is not required when the highest maximum output power for 100% RB allocation is less than the highest maximum output power in 50% and 1 RB allocations and the highest reported SAR for 1 RB and 50% RB allocation are ≤ 0.8 W/kg. Otherwise, SAR is measured for the highest output power channel and if the reported SAR is > 1.45 W/kg, the remaining required test channels must also be tested.
4. SAR is required only when the highest maximum output power for the configuration in the higher order modulation is $> \frac{1}{2}$ dB higher than the same configuration in QPSK or when the reported SAR for the QPSK configuration is > 1.45 W/kg.
5. Only measure SAR when the highest maximum output power of a configuration requiring testing in the smaller channel bandwidth is $> \frac{1}{2}$ dB higher than the equivalent channel configurations in the largest channel bandwidth configuration or the reported SAR of a configuration for the largest channel bandwidth is > 1.45 W/kg.

WiFi

EUT Position	Frequency (MHz)		Test Mode	Antenna Type	Phantom Type	Power Drift (%)	FCC 1g SAR (W/Kg)	
	Channel	MHz					Measurement	Limit
Body-Front (10mm)	1	2412	802.11g	Integral	Universal	/	/	1.6
	6	2437	802.11g	Integral	Universal	/	/	1.6
	11	2462	802.11g	Integral	Universal	-1.231	0.110	1.6
Body-Back (10mm)	1	2412	802.11g	Integral	Universal	/	/	1.6
	6	2437	802.11g	Integral	Universal	/	/	1.6
	11	2462	802.11g	Integral	Universal	0.892	0.021	1.6
Body-Bottom (10mm)	1	2412	802.11g	Integral	Universal	/	/	1.6
	6	2437	802.11g	Integral	Universal	/	/	1.6
	11	2462	802.11g	Integral	Universal	2.014	0.004	1.6
Body-Right (10mm)	1	2412	802.11g	Integral	Universal	/	/	1.6
	6	2437	802.11g	Integral	Universal	/	/	1.6
	11	2462	802.11g	Integral	Universal	-3.241	0.039	1.6

Note:

1. When the 1-g SAR is $\leq 0.8\text{W/Kg}$, testing for other channels are optional.
2. The SAR testing is conducted with 100% duty cycle factor.
3. The output power was tested under data rate 6Mbps for 802.11g.

SAR SIMULTANEOUS TRANSMISSION DESCRIPTION

KDB 447498D01 General RF Exposure Guidance v05
KDB 648474 D04 SAR Handsets Multi Xmitter and Ant v01

Stand-alone and simultaneous SAR evaluation for a device with multiple transmitters is base on the antennas distance of each radio.

WiFi and 3G<E Antenna Location:

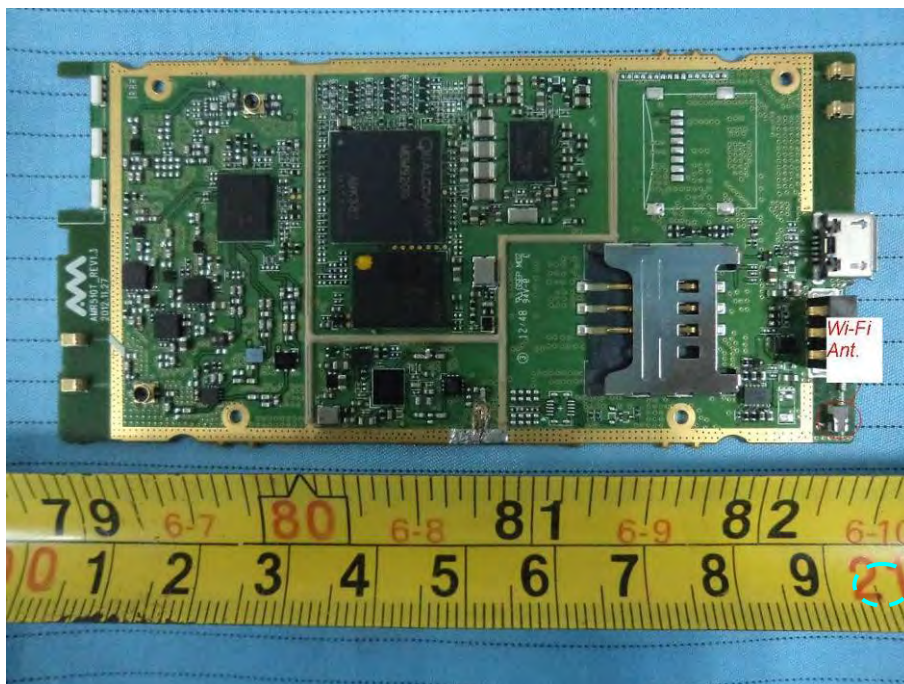
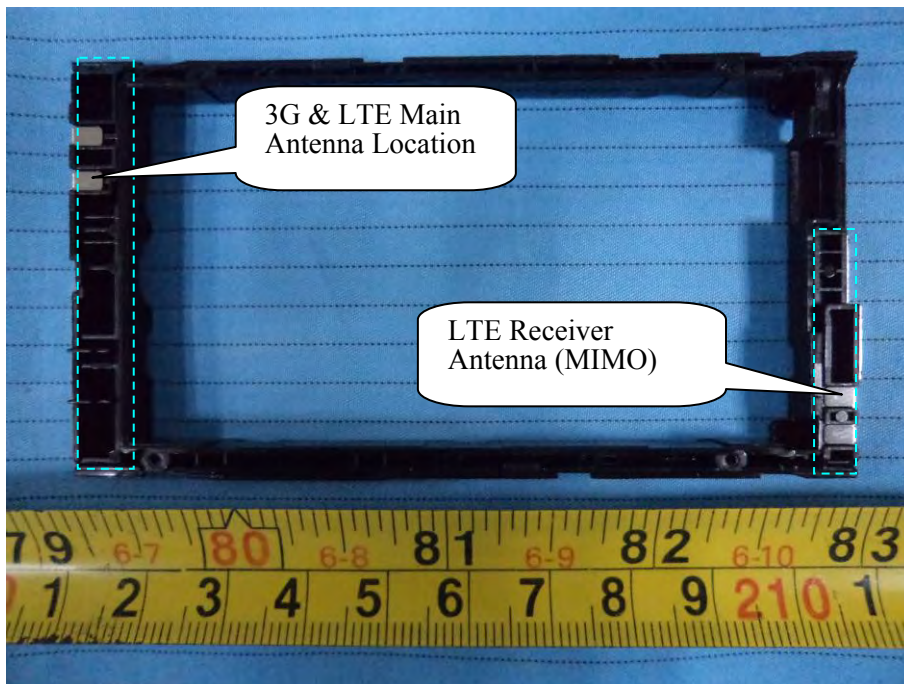

Antenna Information:

Description of Simultaneous Transmit Capabilities			Antennas Distance (mm)
Transmitter Combination	Scenario Supported?	Supported for Mobile Hot Spot	
LTE Band 4 (Data) + WiFi	√	√	82
WCDMA(Data) + WiFi	√	√	82
WCDMA(Data) + LTE Band 4 (Data)	×	×	0

Standalone SAR test exclusion considerations:

Body Position:

Mode	Frequency (MHz)	P _{avg} (dBm)	P _{avg} (mW)	Threshold (1-g)	Distance (mm)	SAR Test Exclusion
WCDMA850	850	23.16	207.014	33	10	No
WCDMA1900	1900	22.78	189.671	22	10	No
LTE Band 4	1800	23.08	203.236	23	10	No
WiFi	2450	19.88	97.275	19	10	No

The 1-g and 10-g SAR test exclusion thresholds for 100 MHz to 6 GHz at *test separation distances* ≤ 50 mm are determined by:

$$[(\text{max. power of channel, including tune-up tolerance, mW}) / (\text{min. test separation distance, mm})] \cdot [\sqrt{f(\text{GHz})}] \leq 3.0 \text{ for 1-g SAR and } \leq 7.5 \text{ for 10-g extremity SAR, where}$$

1. f(GHz) is the RF channel transmit frequency in GHz.
2. Power and distance are rounded to the nearest mW and mm before calculation.
3. The result is rounded to one decimal place for comparison.

Simultaneous Transmission Analysis:

Mode	Position	Reported SAR (W/kg)		ΣSAR
		WCDMA/LTE	WiFi	< 1.6W/kg
WCDMA850	Body-Front	0.397	0.110	0.507
	Body-Back	0.492	0.021	0.513
WCDMA190	Body-Front	1.202	0.110	1.312
	Body-Back	1.343	0.021	1.364
LTE Band 4	Body-Front	1.126	0.110	1.236
	Body-Back	1.193	0.021	1.214

When the sum of 1-g or 10-g SAR of all simultaneously transmitting antennas in an operating mode and exposure condition combination is within the SAR limit, SAR test exclusion applies to that simultaneous transmission configuration.

Mobile Hot-Spot Test Result

The DUT is capable of functioning as wireless router. SAR testing was performed according to KDB 941225 D06. Testing was performed with a separation of 1cm between the DUT and the flat phantom. The DUT was positioned for SAR tests with the front and back surfaces facing the phantom, and also with the edges facing the phantom in which the transmitting antenna is <2.5 cm from the edge. Each transmit band was utilized for SAR testing. The tested mode has been selected within each band that exhibits the highest time average output power.

Hotspot SAR Simultaneous Transmission Analysis:

Evaluations for Simultaneous SAR, Mobile Hot Spot Positions							
Test Position	Stand Alone 1-g SAR (W/Kg)				Σ 1-g SAR (W/Kg)		
	WCDMA 835	WCDMA 1900	LTE	WiFi	WCDMA 835+WiFi	WCDMA 1900 +WiFi	LTE+WiFi
Body-Front (1.0cm)	0.397	1.202	1.126	0.110	0.507	1.312	1.236
Body-Back (1.0cm)	0.492	1.343	1.193	0.021	0.513	1.364	1.214
Body-Top (1.0cm)	0.262	0.334	0.236	/	/	/	/
Body-Bottom (1.0cm)	0.158	0.240	0.168	0.004	0.162	0.244	0.172
Body-Left(1.0cm)	0.065	0.791	0.699	0.039	0.104	0.830	0.738

Note:

1. If the sum of the 1g SAR measured for the simultaneously transmitting antennas is less than the SAR limit, SAR measurement for simultaneous transmission is not required.

EUT SCAN RESULTS

Test Laboratory: Bay Area Compliance Lab Corp. (Shenzhen)

WCDMA850; Body-Front (846.6 MHz High Channel)

Measurement Data

Test mode : WCDMA850
Crest Factor : 1
Scan Type : Complete
Area Scan : 8x11x1: Measurement x=10mm, y=10mm, z=4mm
Zoom Scan : 7x7x7: Measurement x=5mm, y=5mm, z=5mm
Power Drift-Start : 0.422 W/kg
Power Drift-Finish : 0.415 W/kg
Power Drift (%) : -1.427

Tissue Data

Type : Body
Frequency : 846.60 MHz
Epsilon : 54.92 F/m
Sigma : 0.98 S/m
Density : 1000.00 kg/cu. m

Probe Data

Serial No. : 500-00283
Frequency Band : 850
Duty Cycle Factor : 1
Conversion Factor : 6.6
Probe Sensitivity : 1.20 1.20 1.20 $\mu\text{V}/(\text{V}/\text{m})^2$
Compression Point : 95.00 mV
Offset : 1.56 mm

1 gram SAR value : 0.397 W/kg
10 gram SAR value : 0.266 W/kg
Area Scan Peak SAR : 0.440 W/kg
Zoom Scan Peak SAR : 0.620 W/kg

Plot 1#

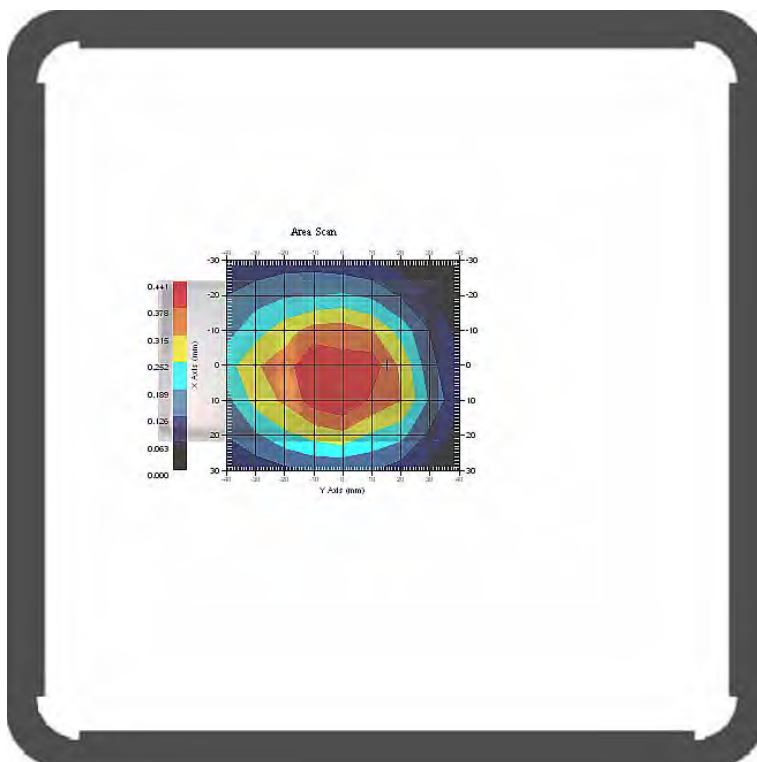

Test Laboratory: Bay Area Compliance Lab Corp. (Shenzhen)

WCDMA850; Body-Back (846.6 MHz High Channel)

Measurement Data

Test mode : WCDMA850
 Crest Factor : 1
 Scan Type : Complete
 Area Scan : 8x11x1: Measurement x=10mm, y=10mm, z=4mm
 Zoom Scan : 7x7x7: Measurement x=5mm, y=5mm, z=5mm
 Power Drift-Start : 0.436 W/kg
 Power Drift-Finish : 0.429 W/kg
 Power Drift (%) : -1.681

Tissue Data

Type : Body
 Frequency : 846.60 MHz
 Epsilon : 54.92 F/m
 Sigma : 0.98 S/m
 Density : 1000.00 kg/cu. m

Probe Data

Serial No. : 500-00283
 Frequency Band : 850
 Duty Cycle Factor : 1
 Conversion Factor : 6.6
 Probe Sensitivity : 1.20 1.20 1.20 $\mu\text{V}/(\text{V/m})^2$
 Compression Point : 95.00 mV
 Offset : 1.56 mm

1 gram SAR value : 0.492 W/kg
 10 gram SAR value : 0.338 W/kg
 Area Scan Peak SAR : 0.556 W/kg
 Zoom Scan Peak SAR : 0.680 W/kg

Plot 2#

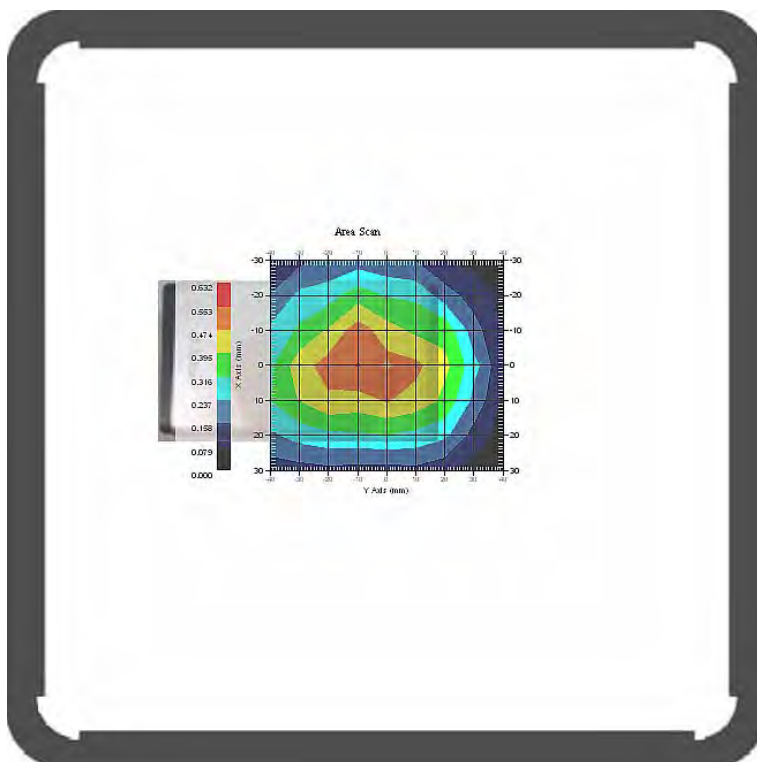

Test Laboratory: Bay Area Compliance Lab Corp. (Shenzhen)

WCDMA850; Body-Top (846.6 MHz High Channel)

Measurement Data

Test mode : WCDMA850
 Crest Factor : 1
 Scan Type : Complete
 Area Scan : 8x11x1: Measurement x=10mm, y=10mm, z=4mm
 Zoom Scan : 7x7x7: Measurement x=5mm, y=5mm, z=5mm
 Power Drift-Start : 0.201 W/kg
 Power Drift-Finish : 0.204 W/kg
 Power Drift (%) : 1.486

Tissue Data

Type : Body
 Frequency : 846.60 MHz
 Epsilon : 54.92 F/m
 Sigma : 0.98 S/m
 Density : 1000.00 kg/cu. m

Probe Data

Serial No. : 500-00283
 Frequency Band : 850
 Duty Cycle Factor : 1
 Conversion Factor : 6.6
 Probe Sensitivity : 1.20 1.20 1.20 $\mu\text{V}/(\text{V}/\text{m})^2$
 Compression Point : 95.00 mV
 Offset : 1.56 mm

1 gram SAR value : 0.262 W/kg
 10 gram SAR value : 0.156 W/kg
 Area Scan Peak SAR : 0.275 W/kg
 Zoom Scan Peak SAR : 0.410 W/kg

Plot 3#

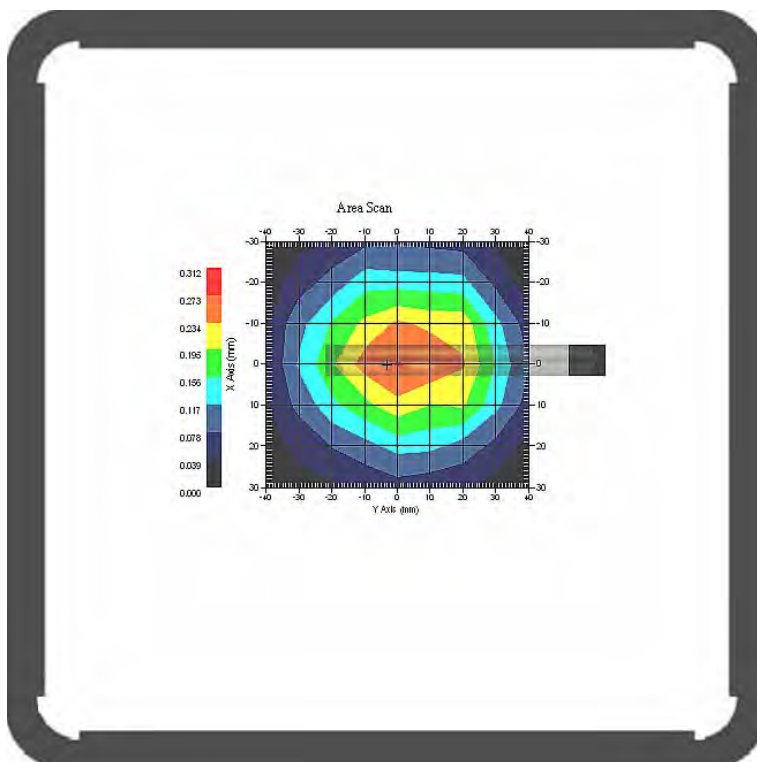

Test Laboratory: Bay Area Compliance Lab Corp. (Shenzhen)

WCDMA850; Body-Bottom (846.6 MHz High Channel)

Measurement Data

Test mode : WCDMA850
 Crest Factor : 1
 Scan Type : Complete
 Area Scan : 8x11x1: Measurement x=10mm, y=10mm, z=4mm
 Zoom Scan : 7x7x7: Measurement x=5mm, y=5mm, z=5mm
 Power Drift-Start : 0.148 W/kg
 Power Drift-Finish : 0.145 W/kg
 Power Drift (%) : -2.085

Tissue Data

Type : Body
 Frequency : 846.60 MHz
 Epsilon : 54.92 F/m
 Sigma : 0.98 S/m
 Density : 1000.00 kg/cu. m

Probe Data

Serial No. : 500-00283
 Frequency Band : 850
 Duty Cycle Factor : 1
 Conversion Factor : 6.6
 Probe Sensitivity : 1.20 1.20 1.20 $\mu\text{V}/(\text{V}/\text{m})^2$
 Compression Point : 95.00 mV
 Offset : 1.56 mm

1 gram SAR value : 0.158 W/kg
 10 gram SAR value : 0.082 W/kg
 Area Scan Peak SAR : 0.165 W/kg
 Zoom Scan Peak SAR : 0.240 W/kg

Plot 4#

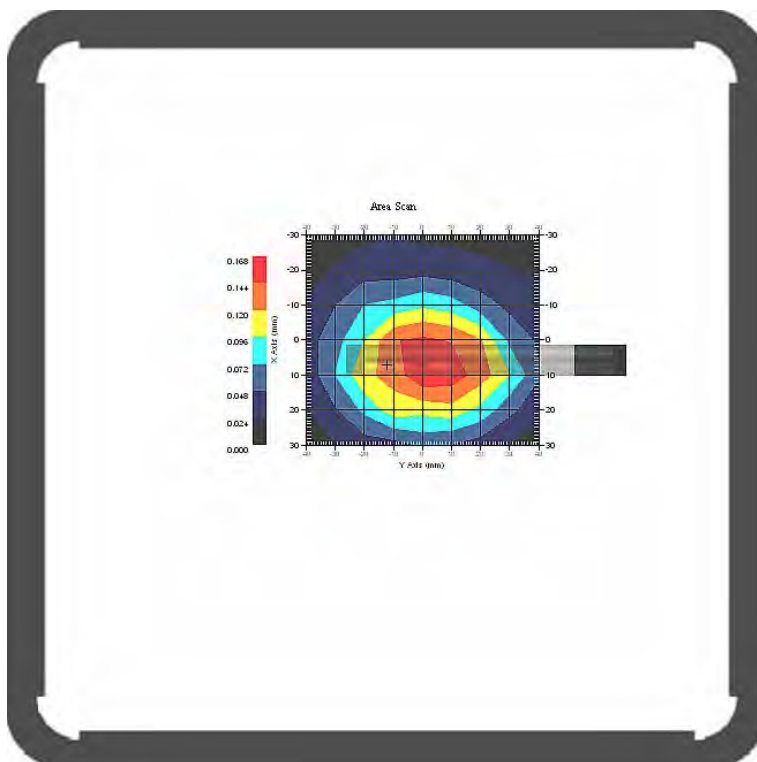

Test Laboratory: Bay Area Compliance Lab Corp. (Shenzhen)

WCDMA850; Body-Left (846.6 MHz High Channel)

Measurement Data

Test mode : WCDMA850
 Crest Factor : 1
 Scan Type : Complete
 Area Scan : 8x11x1: Measurement x=10mm, y=10mm, z=4mm
 Zoom Scan : 7x7x7: Measurement x=5mm, y=5mm, z=5mm
 Power Drift-Start : 0.058 W/kg
 Power Drift-Finish : 0.059 W/kg
 Power Drift (%) : 1.592

Tissue Data

Type : Body
 Frequency : 846.60 MHz
 Epsilon : 54.92 F/m
 Sigma : 0.98 S/m
 Density : 1000.00 kg/cu. m

Probe Data

Serial No. : 500-00283
 Frequency Band : 850
 Duty Cycle Factor : 1
 Conversion Factor : 6.6
 Probe Sensitivity : 1.20 1.20 1.20 $\mu\text{V}/(\text{V/m})^2$
 Compression Point : 95.00 mV
 Offset : 1.56 mm

1 gram SAR value : 0.065 W/kg
 10 gram SAR value : 0.031 W/kg
 Area Scan Peak SAR : 0.075 W/kg
 Zoom Scan Peak SAR : 0.170 W/kg

Plot 5#

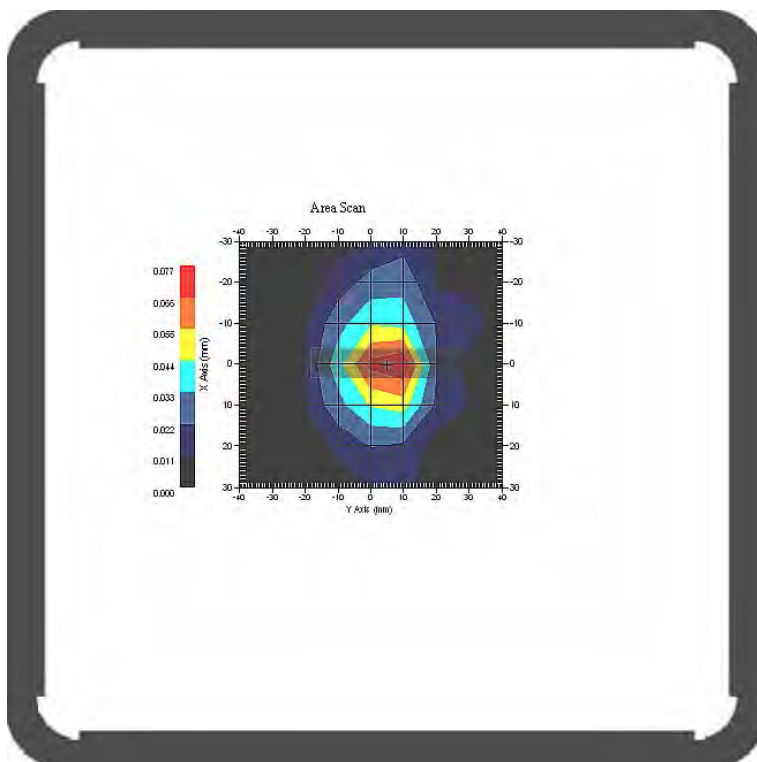

Test Laboratory: Bay Area Compliance Lab Corp. (Shenzhen)

WCDMA1900; Body-Front (1852.4 MHz Low Channel)

Measurement Data

Test mode : WCDMA1900
 Crest Factor : 1
 Scan Type : Complete
 Area Scan : 8x11x1: Measurement x=10mm, y=10mm, z=4mm
 Zoom Scan : 7x7x7: Measurement x=5mm, y=5mm, z=5mm
 Power Drift-Start : 1.253 W/kg
 Power Drift-Finish : 1.240 W/kg
 Power Drift (%) : -1.078

Tissue Data

Type : Body
 Frequency : 1852.40 MHz
 Epsilon : 54.02 F/m
 Sigma : 1.48 S/m
 Density : 1000.00 kg/cu. m

Probe Data

Serial No. : 500-00283
 Frequency Band : 1900
 Duty Cycle Factor : 1
 Conversion Factor : 5.0
 Probe Sensitivity : 1.20 1.20 1.20 $\mu\text{V}/(\text{V}/\text{m})^2$
 Compression Point : 95.00 mV
 Offset : 1.56 mm

1 gram SAR value : 1.202 W/kg
 10 gram SAR value : 0.702 W/kg
 Area Scan Peak SAR : 1.333 W/kg
 Zoom Scan Peak SAR : 2.000 W/kg

Plot 6#

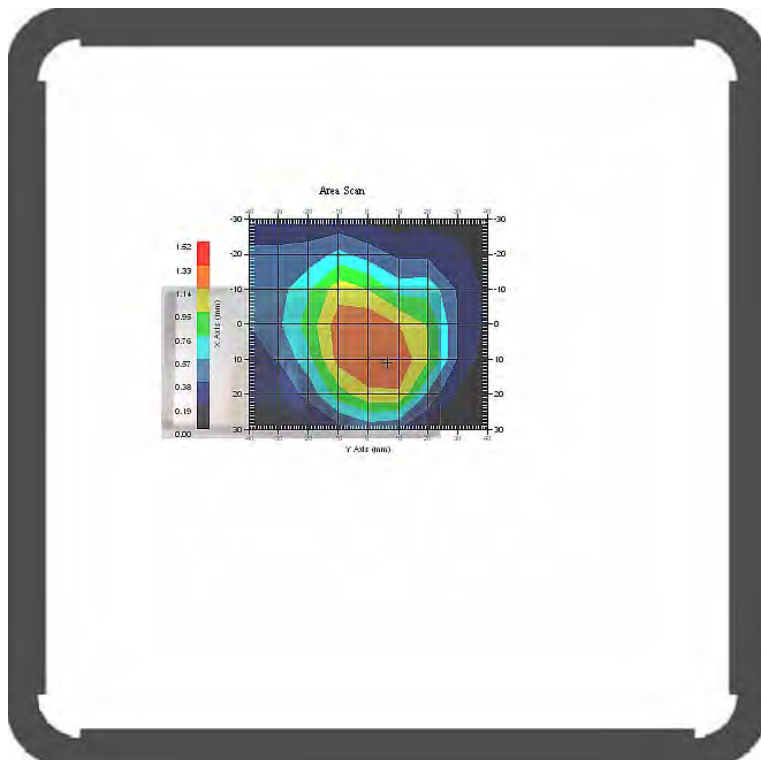

Test Laboratory: Bay Area Compliance Lab Corp. (Shenzhen)

WCDMA1900; Body-Front (1880.0 MHz Middle Channel)

Measurement Data

Test mode : WCDMA1900
 Crest Factor : 1
 Scan Type : Complete
 Area Scan : 8x11x1: Measurement x=10mm, y=10mm, z=4mm
 Zoom Scan : 7x7x7: Measurement x=5mm, y=5mm, z=5mm
 Power Drift-Start : 1.185 W/kg
 Power Drift-Finish : 1.204 W/kg
 Power Drift (%) : 1.883

Tissue Data

Type : Body
 Frequency : 1880.00 MHz
 Epsilon : 53.82 F/m
 Sigma : 1.52 S/m
 Density : 1000.00 kg/cu. m

Probe Data

Serial No. : 500-00283
 Frequency Band : 1900
 Duty Cycle Factor : 1
 Conversion Factor : 5.0
 Probe Sensitivity : 1.20 1.20 1.20 $\mu\text{V}/(\text{V}/\text{m})^2$
 Compression Point : 95.00 mV
 Offset : 1.56 mm

1 gram SAR value : 1.152 W/kg
 10 gram SAR value : 0.625 W/kg
 Area Scan Peak SAR : 1.271 W/kg
 Zoom Scan Peak SAR : 2.181 W/kg

Plot 7#

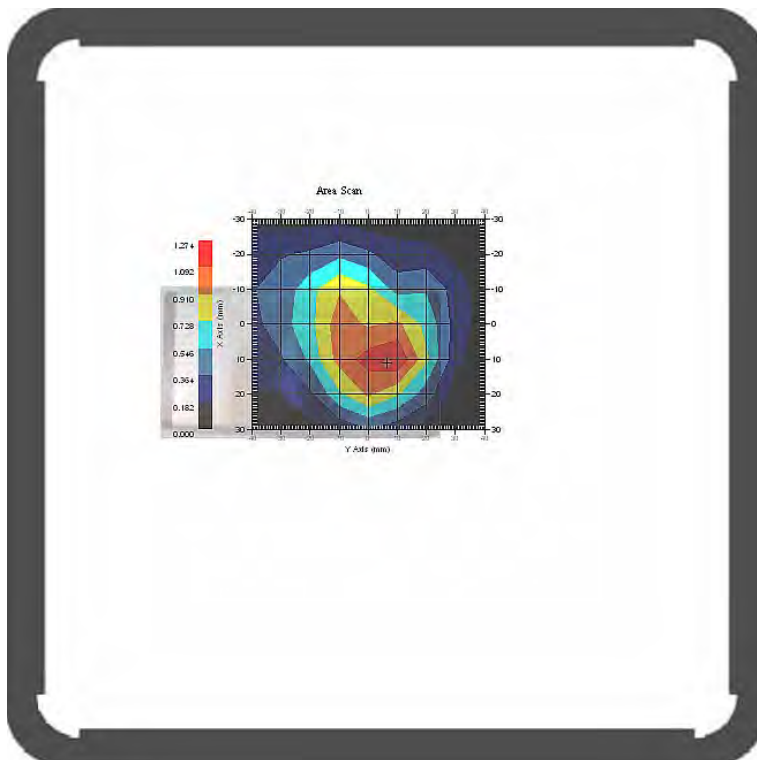

Test Laboratory: Bay Area Compliance Lab Corp. (Shenzhen)

WCDMA1900; Body-Front (1907.60 MHz High Channel)

Measurement Data

Test mode : WCDMA1900
 Crest Factor : 1
 Scan Type : Complete
 Area Scan : 8x11x1: Measurement x=10mm, y=10mm, z=4mm
 Zoom Scan : 7x7x7: Measurement x=5mm, y=5mm, z=5mm
 Power Drift-Start : 0.795 W/kg
 Power Drift-Finish : 0.811 W/kg
 Power Drift (%) : 2.108

Tissue Data

Type : Body
 Frequency : 1907.60 MHz
 Epsilon : 53.78 F/m
 Sigma : 1.54 S/m
 Density : 1000.00 kg/cu. m

Probe Data

Serial No. : 500-00283
 Frequency Band : 1900
 Duty Cycle Factor : 1
 Conversion Factor : 5.0
 Probe Sensitivity : 1.20 1.20 1.20 $\mu\text{V}/(\text{V/m})^2$
 Compression Point : 95.00 mV
 Offset : 1.56 mm

1 gram SAR value : 0.797 W/kg
 10 gram SAR value : 0.412 W/kg
 Area Scan Peak SAR : 0.904 W/kg
 Zoom Scan Peak SAR : 1.511 W/kg

Plot 8#

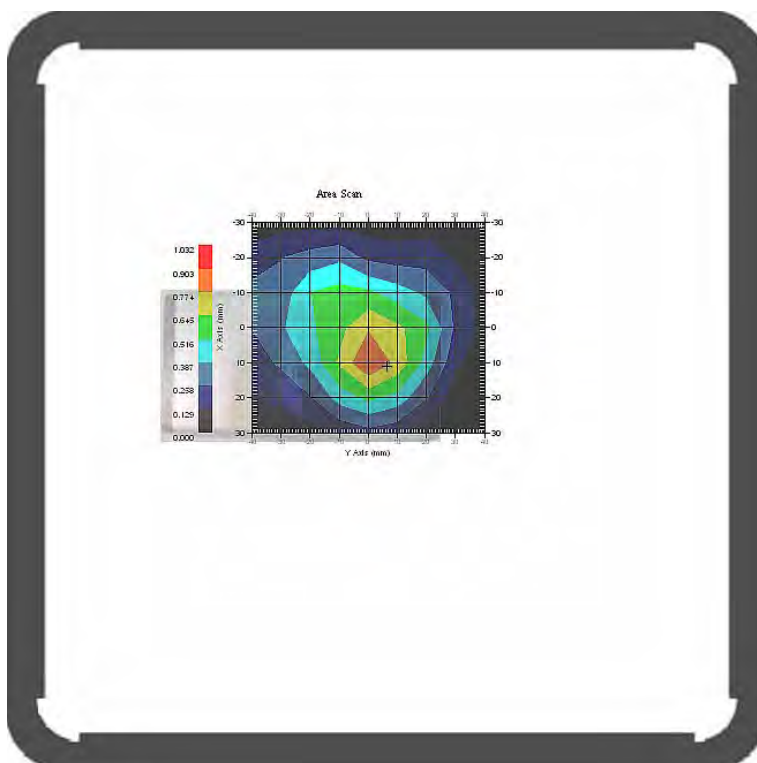

Test Laboratory: Bay Area Compliance Lab Corp. (Shenzhen)

WCDMA1900; Body-Back (1852.4 MHz Low Channel)

Measurement Data

Test mode : WCDMA1900
 Crest Factor : 1
 Scan Type : Complete
 Area Scan : 8x11x1: Measurement x=10mm, y=10mm, z=4mm
 Zoom Scan : 7x7x7: Measurement x=5mm, y=5mm, z=5mm
 Power Drift-Start : 1.021 W/kg
 Power Drift-Finish : 1.009 W/kg
 Power Drift (%) : -1.207

Tissue Data

Type : Body
 Frequency : 1852.40 MHz
 Epsilon : 54.02 F/m
 Sigma : 1.48 S/m
 Density : 1000.00 kg/cu. m

Probe Data

Serial No. : 500-00283
 Frequency Band : 1900
 Duty Cycle Factor : 1
 Conversion Factor : 5.0
 Probe Sensitivity : 1.20 1.20 1.20 $\mu\text{V}/(\text{V}/\text{m})^2$
 Compression Point : 95.00 mV
 Offset : 1.56 mm

1 gram SAR value : 1.343 W/kg
 10 gram SAR value : 0.715 W/kg
 Area Scan Peak SAR : 1.417 W/kg
 Zoom Scan Peak SAR : 2.362 W/kg

Plot 9#

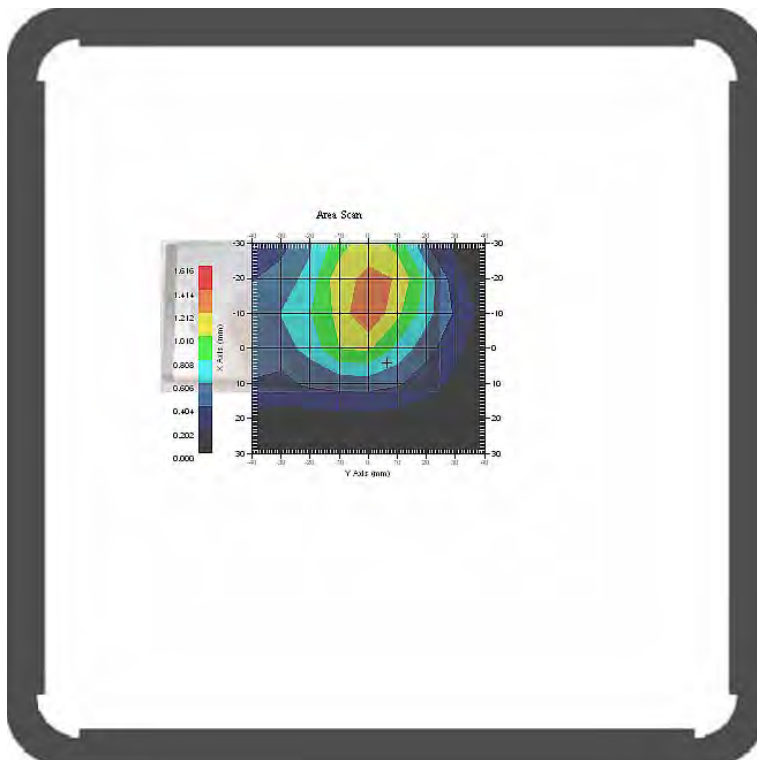

Test Laboratory: Bay Area Compliance Lab Corp. (Shenzhen)

WCDMA1900; Body-Back (1880.0 MHz Middle Channel)

Measurement Data

Test mode : WCDMA1900
 Crest Factor : 1
 Scan Type : Complete
 Area Scan : 8x11x1: Measurement x=10mm, y=10mm, z=4mm
 Zoom Scan : 7x7x7: Measurement x=5mm, y=5mm, z=5mm
 Power Drift-Start : 1.204 W/kg
 Power Drift-Finish : 1.188 W/kg
 Power Drift (%) : -1.353

Tissue Data

Type : Body
 Frequency : 1880.00 MHz
 Epsilon : 53.82 F/m
 Sigma : 1.52 S/m
 Density : 1000.00 kg/cu. m

Probe Data

Serial No. : 500-00283
 Frequency Band : 1900
 Duty Cycle Factor : 1
 Conversion Factor : 5.0
 Probe Sensitivity : 1.20 1.20 1.20 $\mu\text{V}/(\text{V/m})^2$
 Compression Point : 95.00 mV
 Offset : 1.56 mm

1 gram SAR value : 1.223 W/kg
 10 gram SAR value : 0.765 W/kg
 Area Scan Peak SAR : 1.184 W/kg
 Zoom Scan Peak SAR : 2.101 W/kg

Plot 10#

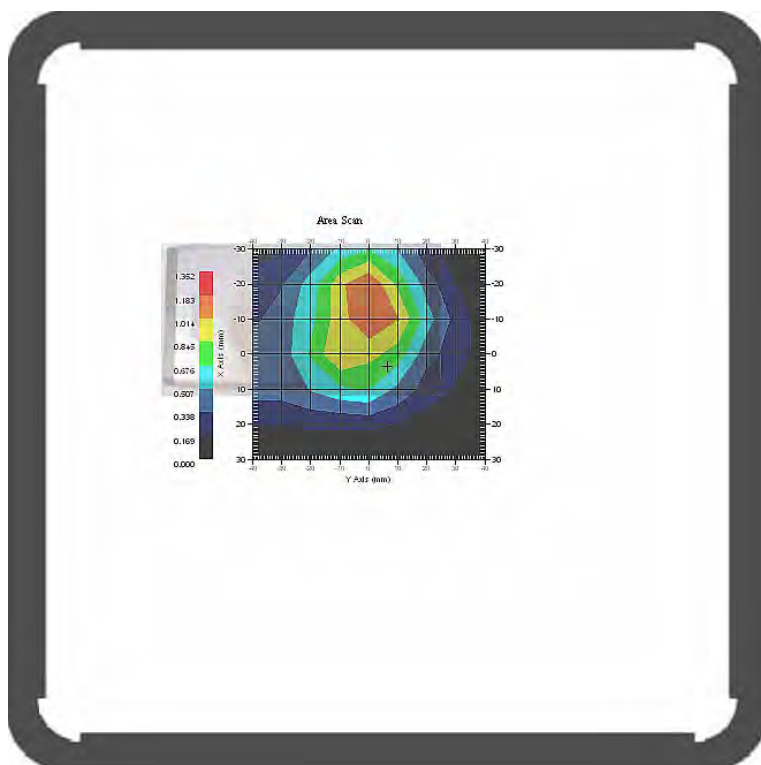

Test Laboratory: Bay Area Compliance Lab Corp. (Shenzhen)

WCDMA1900; Body-Back (1907.60 MHz High Channel)

Measurement Data

Test mode : WCDMA1900
 Crest Factor : 1
 Scan Type : Complete
 Area Scan : 8x11x1: Measurement x=10mm, y=10mm, z=4mm
 Zoom Scan : 7x7x7: Measurement x=5mm, y=5mm, z=5mm
 Power Drift-Start : 0.677 W/kg
 Power Drift-Finish : 0.671 W/kg
 Power Drift (%) : -0.895

Tissue Data

Type : Body
 Frequency : 1907.60 MHz
 Epsilon : 53.78 F/m
 Sigma : 1.54 S/m
 Density : 1000.00 kg/cu. m

Probe Data

Serial No. : 500-00283
 Frequency Band : 1900
 Duty Cycle Factor : 1
 Conversion Factor : 5.0
 Probe Sensitivity : 1.20 1.20 1.20 $\mu\text{V}/(\text{V}/\text{m})^2$
 Compression Point : 95.00 mV
 Offset : 1.56 mm

1 gram SAR value : 0.620 W/kg
 10 gram SAR value : 0.303 W/kg
 Area Scan Peak SAR : 0.713 W/kg
 Zoom Scan Peak SAR : 1.080 W/kg

Plot 11#

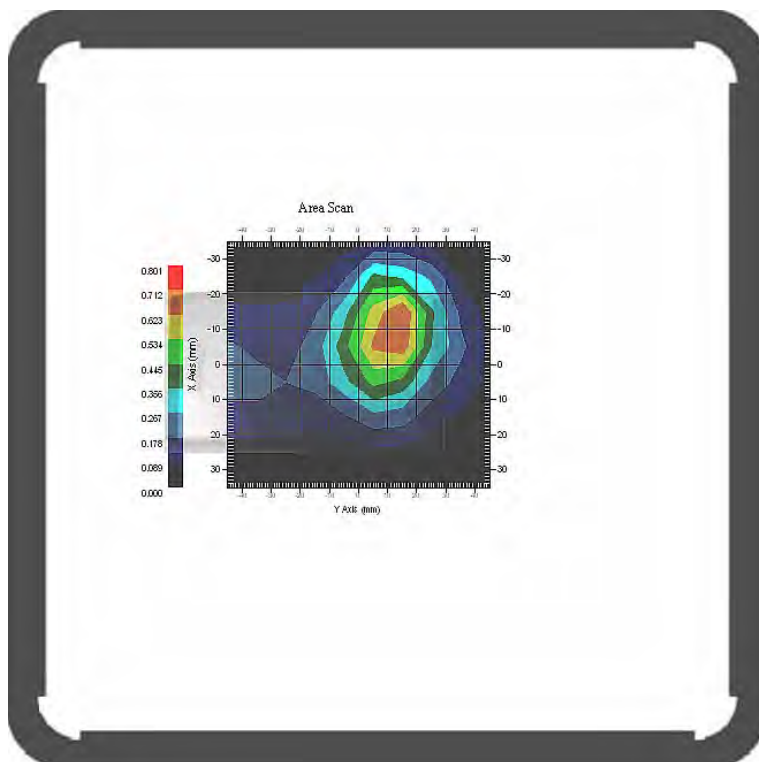

Test Laboratory: Bay Area Compliance Lab Corp. (Shenzhen)

WCDMA1900; Body-Top (1852.4 MHz Low Channel)

Measurement Data

Test mode : WCDMA1900
 Crest Factor : 1
 Scan Type : Complete
 Area Scan : 8x11x1: Measurement x=10mm, y=10mm, z=4mm
 Zoom Scan : 7x7x7: Measurement x=5mm, y=5mm, z=5mm
 Power Drift-Start : 0.321 W/kg
 Power Drift-Finish : 0.315 W/kg
 Power Drift (%) : -1.897

Tissue Data

Type : Body
 Frequency : 1852.40 MHz
 Epsilon : 54.02 F/m
 Sigma : 1.48 S/m
 Density : 1000.00 kg/cu. m

Probe Data

Serial No. : 500-00283
 Frequency Band : 1900
 Duty Cycle Factor : 1
 Conversion Factor : 5.0
 Probe Sensitivity : 1.20 1.20 1.20 $\mu\text{V}/(\text{V}/\text{m})^2$
 Compression Point : 95.00 mV
 Offset : 1.56 mm

1 gram SAR value : 0.334 W/kg
 10 gram SAR value : 0.163 W/kg
 Area Scan Peak SAR : 0.340 W/kg
 Zoom Scan Peak SAR : 0.610 W/kg

Plot 12#

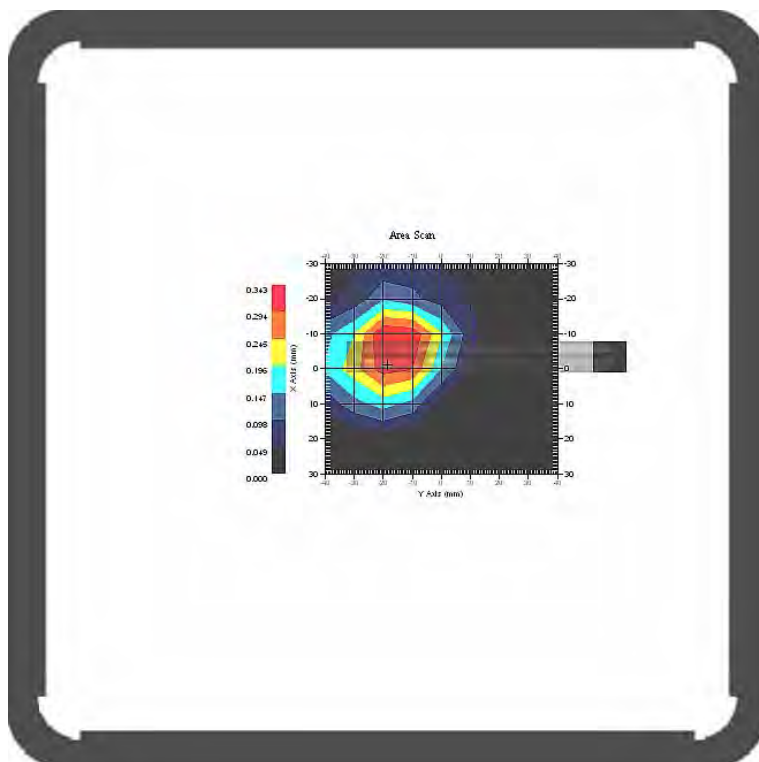

Test Laboratory: Bay Area Compliance Lab Corp. (Shenzhen)

WCDMA1900; Body-Bottom (1852.4 MHz Low Channel)

Measurement Data

Test mode : WCDMA1900
 Crest Factor : 1
 Scan Type : Complete
 Area Scan : 8x11x1: Measurement x=10mm, y=10mm, z=4mm
 Zoom Scan : 7x7x7: Measurement x=5mm, y=5mm, z=5mm
 Power Drift-Start : 0.215 W/kg
 Power Drift-Finish : 0.220 W/kg
 Power Drift (%) : 2.357

Tissue Data

Type : Body
 Frequency : 1852.40 MHz
 Epsilon : 54.02 F/m
 Sigma : 1.48 S/m
 Density : 1000.00 kg/cu. m

Probe Data

Serial No. : 500-00283
 Frequency Band : 1900
 Duty Cycle Factor : 1
 Conversion Factor : 5.0
 Probe Sensitivity : 1.20 1.20 1.20 $\mu\text{V}/(\text{V}/\text{m})^2$
 Compression Point : 95.00 mV
 Offset : 1.56 mm

1 gram SAR value : 0.240 W/kg
 10 gram SAR value : 0.112 W/kg
 Area Scan Peak SAR : 0.250 W/kg
 Zoom Scan Peak SAR : 0.500 W/kg

Plot 13#

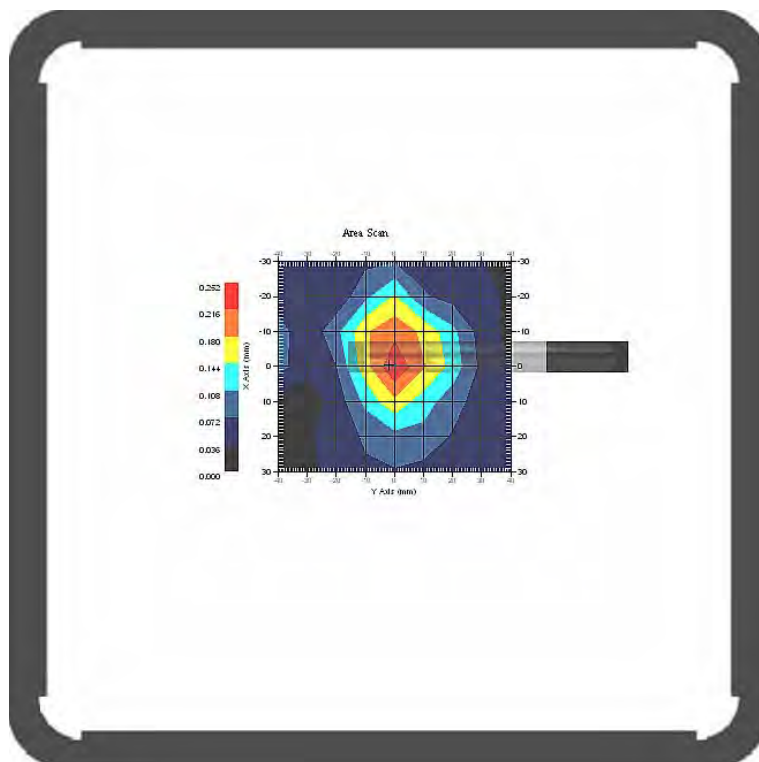

Test Laboratory: Bay Area Compliance Lab Corp. (Shenzhen)

WCDMA1900; Body-Left (1852.4 MHz Low Channel)

Measurement Data

Test mode : WCDMA1900
 Crest Factor : 1
 Scan Type : Complete
 Area Scan : 8x11x1: Measurement x=10mm, y=10mm, z=4mm
 Zoom Scan : 7x7x7: Measurement x=5mm, y=5mm, z=5mm
 Power Drift-Start : 0.751 W/kg
 Power Drift-Finish : 0.760 W/kg
 Power Drift (%) : 1.328

Tissue Data

Type : Body
 Frequency : 1852.40 MHz
 Epsilon : 54.02 F/m
 Sigma : 1.48 S/m
 Density : 1000.00 kg/cu. m

Probe Data

Serial No. : 500-00283
 Frequency Band : 1900
 Duty Cycle Factor : 1
 Conversion Factor : 5.0
 Probe Sensitivity : 1.20 1.20 1.20 $\mu\text{V}/(\text{V}/\text{m})^2$
 Compression Point : 95.00 mV
 Offset : 1.56 mm

1 gram SAR value : 0.791 W/kg
 10 gram SAR value : 0.396 W/kg
 Area Scan Peak SAR : 0.994 W/kg
 Zoom Scan Peak SAR : 1.501 W/kg

Plot 14#

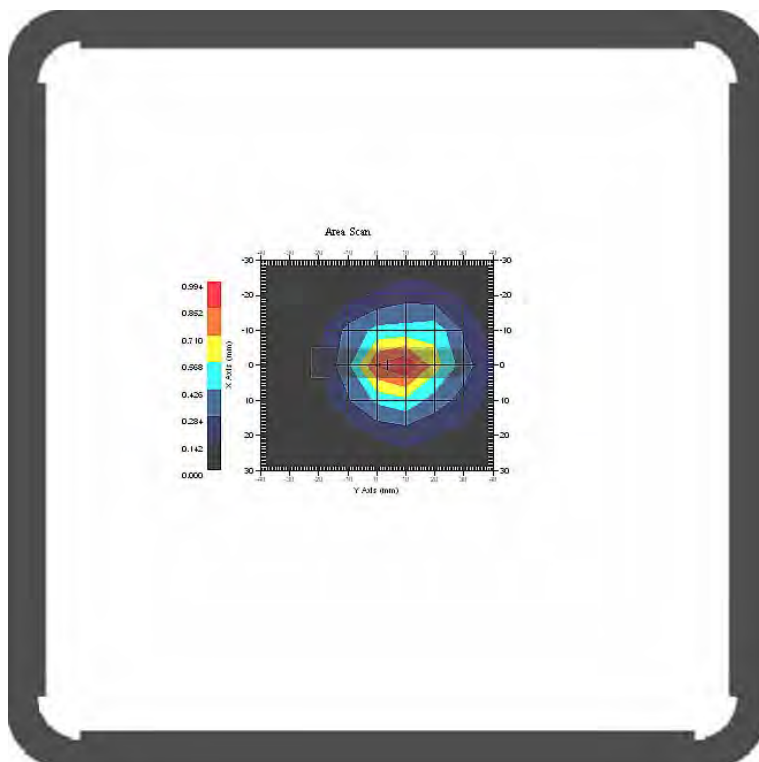

Test Laboratory: Bay Area Compliance Lab Corp. (Shenzhen)

LTE Band 4—1 RB; Body-Front (1732.5 MHz Middle Channel)

Measurement Data

Test mode : LTE
 Crest Factor : 1
 Scan Type : Complete
 Area Scan : 8x11x1: Measurement x=10mm, y=10mm, z=4mm
 Zoom Scan : 7x7x7: Measurement x=5mm, y=5mm, z=5mm
 Power Drift-Start : 0.985 W/kg
 Power Drift-Finish : 1.012 W/kg
 Power Drift (%) : 2.498

Tissue Data

Type : Body
 Frequency : 1732.50 MHz
 Epsilon : 53.76 F/m
 Sigma : 1.53 S/m
 Density : 1000.00 kg/cu. m

Probe Data

Serial No. : 500-00283
 Frequency Band : 1800
 Duty Cycle Factor : 1
 Conversion Factor : 5.0
 Probe Sensitivity : 1.20 1.20 1.20 $\mu\text{V}/(\text{V/m})^2$
 Compression Point : 95.00 mV
 Offset : 1.56 mm

1 gram SAR value : 1.074 W/kg
 10 gram SAR value : 0.549 W/kg
 Area Scan Peak SAR : 1.112 W/kg
 Zoom Scan Peak SAR : 1.991 W/kg

Plot 15#

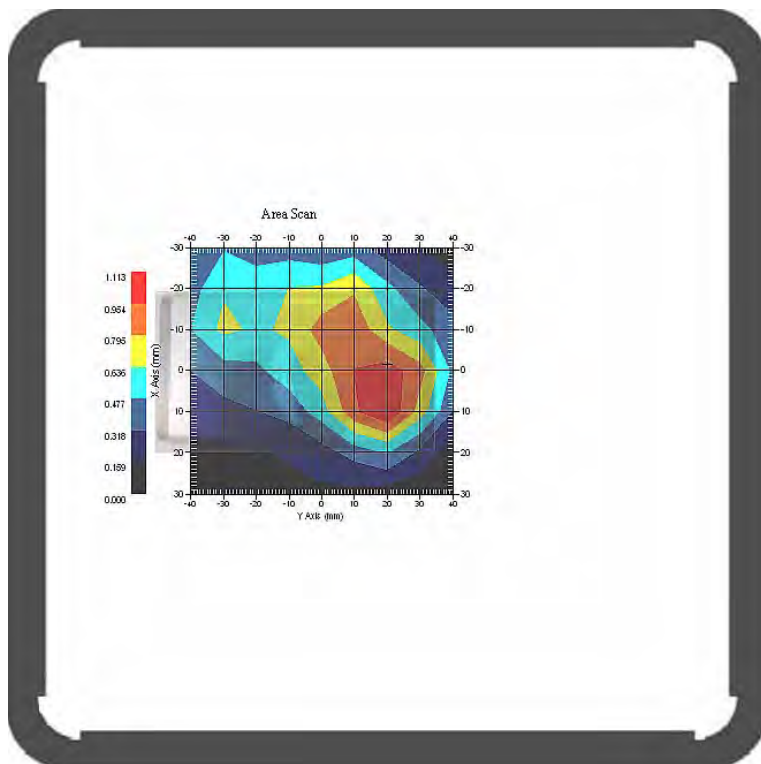

Test Laboratory: Bay Area Compliance Lab Corp. (Shenzhen)

LTE Band 4—1 RB; Body-Back (1732.5 MHz Middle Channel)

Measurement Data

Test mode : LTE
 Crest Factor : 1
 Scan Type : Complete
 Area Scan : 8x11x1: Measurement x=10mm, y=10mm, z=4mm
 Zoom Scan : 7x7x7: Measurement x=5mm, y=5mm, z=5mm
 Power Drift-Start : 1.085 W/kg
 Power Drift-Finish : 1.112 W/kg
 Power Drift (%) : 1.524

Tissue Data

Type : Body
 Frequency : 1732.50 MHz
 Epsilon : 53.76 F/m
 Sigma : 1.53 S/m
 Density : 1000.00 kg/cu. m

Probe Data

Serial No. : 500-00283
 Frequency Band : 1800
 Duty Cycle Factor : 1
 Conversion Factor : 5.0
 Probe Sensitivity : 1.20 1.20 1.20 $\mu\text{V}/(\text{V}/\text{m})^2$
 Compression Point : 95.00 mV
 Offset : 1.56 mm

1 gram SAR value : 1.193 W/kg
 10 gram SAR value : 0.709 W/kg
 Area Scan Peak SAR : 1.298 W/kg
 Zoom Scan Peak SAR : 2.161 W/kg

Plot 16#

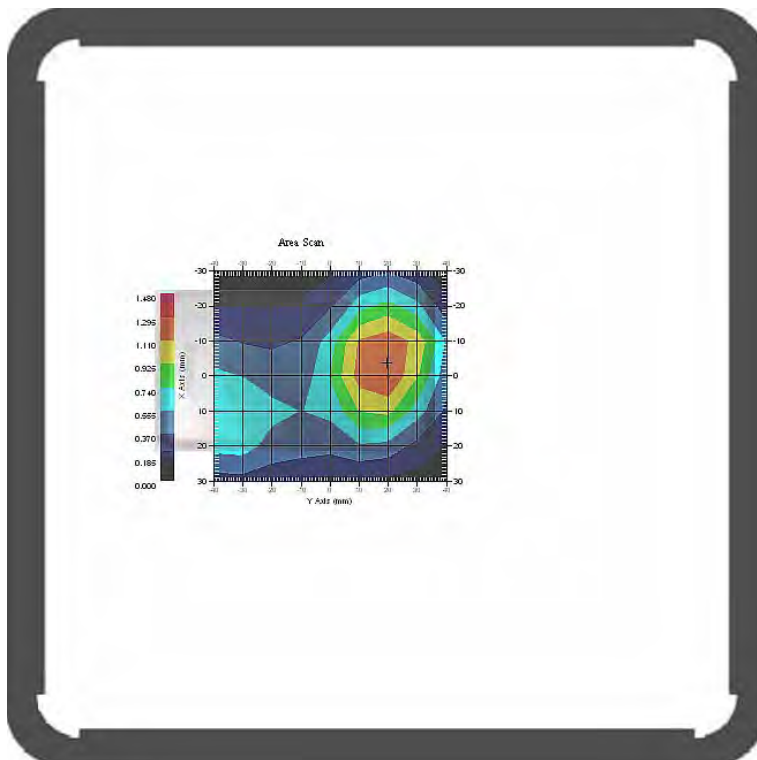

Test Laboratory: Bay Area Compliance Lab Corp. (Shenzhen)

LTE Band 4—1 RB; Body-Top (1732.5 MHz Middle Channel)

Measurement Data

Test mode : LTE
 Crest Factor : 1
 Scan Type : Complete
 Area Scan : 8x11x1: Measurement x=10mm, y=10mm, z=4mm
 Zoom Scan : 7x7x7: Measurement x=5mm, y=5mm, z=5mm
 Power Drift-Start : 0.215 W/kg
 Power Drift-Finish : 0.219 W/kg
 Power Drift (%) : 1.859

Tissue Data

Type : Body
 Frequency : 1732.50 MHz
 Epsilon : 53.76 F/m
 Sigma : 1.53 S/m
 Density : 1000.00 kg/cu. m

Probe Data

Serial No. : 500-00283
 Frequency Band : 1800
 Duty Cycle Factor : 1
 Conversion Factor : 5.0
 Probe Sensitivity : 1.20 1.20 1.20 $\mu\text{V}/(\text{V/m})^2$
 Compression Point : 95.00 mV
 Offset : 1.56 mm

1 gram SAR value : 0.236 W/kg
 10 gram SAR value : 0.119 W/kg
 Area Scan Peak SAR : 0.251 W/kg
 Zoom Scan Peak SAR : 0.360 W/kg

Plot 17#

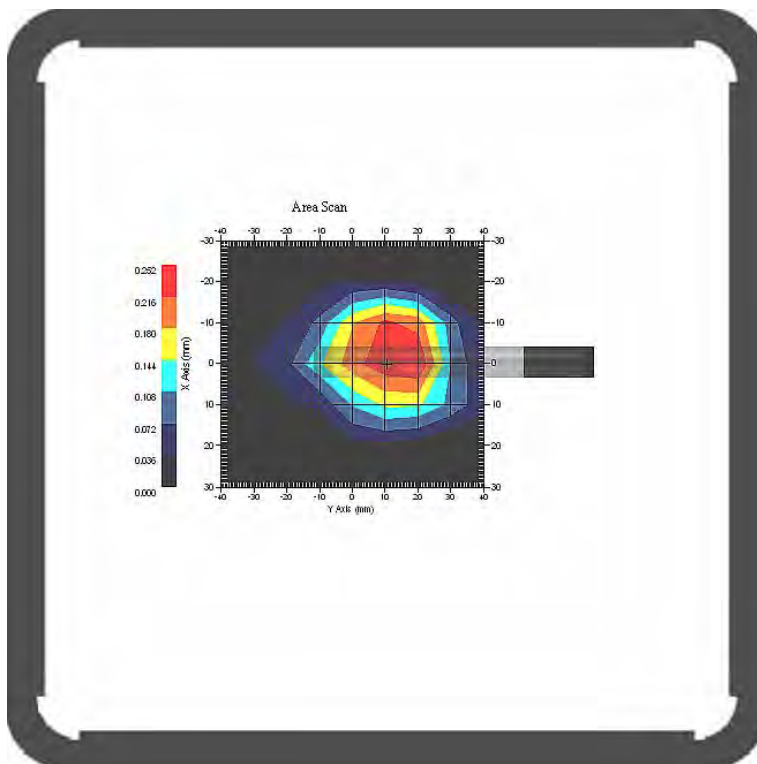

Test Laboratory: Bay Area Compliance Lab Corp. (Shenzhen)

LTE Band 4—1 RB; Body-Bottom (1732.5 MHz Middle Channel)

Measurement Data

Test mode : LTE
 Crest Factor : 1
 Scan Type : Complete
 Area Scan : 8x11x1: Measurement x=10mm, y=10mm, z=4mm
 Zoom Scan : 7x7x7: Measurement x=5mm, y=5mm, z=5mm
 Power Drift-Start : 0.162 W/kg
 Power Drift-Finish : 0.160 W/kg
 Power Drift (%) : -1.502

Tissue Data

Type : Body
 Frequency : 1732.50 MHz
 Epsilon : 53.76 F/m
 Sigma : 1.53 S/m
 Density : 1000.00 kg/cu. m

Probe Data

Serial No. : 500-00283
 Frequency Band : 1800
 Duty Cycle Factor : 1
 Conversion Factor : 5.0
 Probe Sensitivity : 1.20 1.20 1.20 $\mu\text{V}/(\text{V}/\text{m})^2$
 Compression Point : 95.00 mV
 Offset : 1.56 mm

1 gram SAR value : 0.168 W/kg
 10 gram SAR value : 0.066 W/kg
 Area Scan Peak SAR : 0.191 W/kg
 Zoom Scan Peak SAR : 0.400 W/kg

Plot 18#

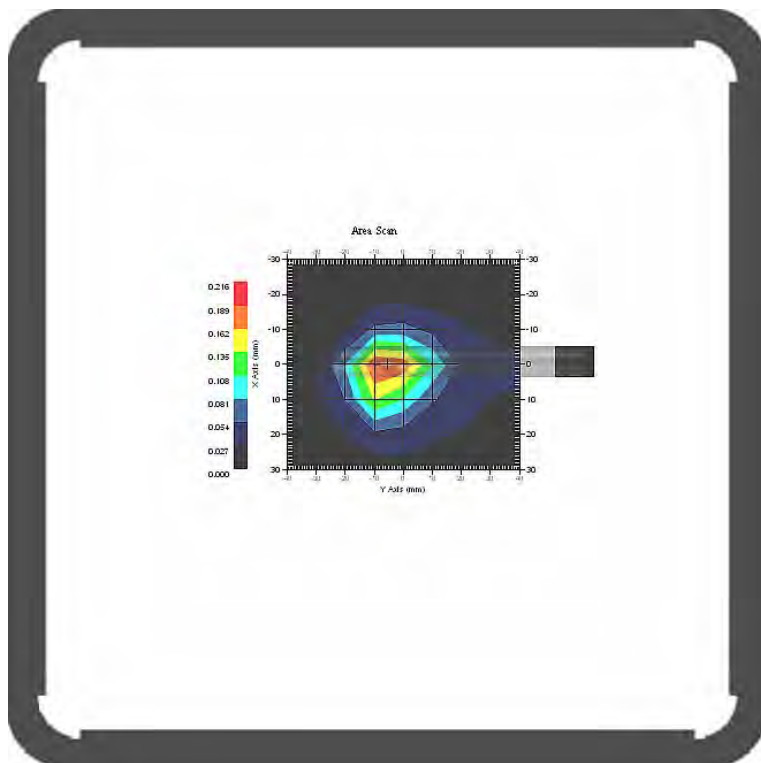

Test Laboratory: Bay Area Compliance Lab Corp. (Shenzhen)

LTE Band 4—1 RB; Body-Left (1732.5 MHz Middle Channel)

Measurement Data

Test mode : LTE
 Crest Factor : 1
 Scan Type : Complete
 Area Scan : 8x11x1: Measurement x=10mm, y=10mm, z=4mm
 Zoom Scan : 7x7x7: Measurement x=5mm, y=5mm, z=5mm
 Power Drift-Start : 0.596 W/kg
 Power Drift-Finish : 0.605 W/kg
 Power Drift (%) : 1.588

Tissue Data

Type : Body
 Frequency : 1732.50 MHz
 Epsilon : 53.76 F/m
 Sigma : 1.53 S/m
 Density : 1000.00 kg/cu. m

Probe Data

Serial No. : 500-00283
 Frequency Band : 1800
 Duty Cycle Factor : 1
 Conversion Factor : 5.0
 Probe Sensitivity : 1.20 1.20 1.20 $\mu\text{V}/(\text{V/m})^2$
 Compression Point : 95.00 mV
 Offset : 1.56 mm

1 gram SAR value : 0.623 W/kg
 10 gram SAR value : 0.302 W/kg
 Area Scan Peak SAR : 0.736 W/kg
 Zoom Scan Peak SAR : 1.050 W/kg

Plot 19#

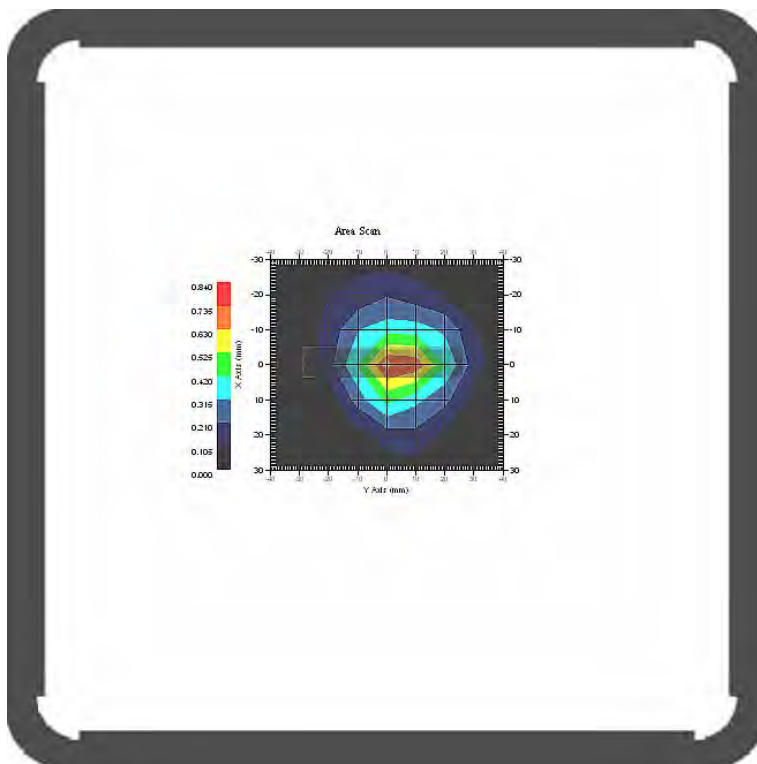

Test Laboratory: Bay Area Compliance Lab Corp. (Shenzhen)

LTE Band 4—50 RB; Body-Front (1732.5 MHz Middle Channel)

Measurement Data

Test mode : LTE
 Crest Factor : 1
 Scan Type : Complete
 Area Scan : 8x11x1: Measurement x=10mm, y=10mm, z=4mm
 Zoom Scan : 7x7x7: Measurement x=5mm, y=5mm, z=5mm
 Power Drift-Start : 0.729 W/kg
 Power Drift-Finish : 0.711 W/kg
 Power Drift (%) : -2.285

Tissue Data

Type : Body
 Frequency : 1732.50 MHz
 Epsilon : 53.76 F/m
 Sigma : 1.53 S/m
 Density : 1000.00 kg/cu. m

Probe Data

Serial No. : 500-00283
 Frequency Band : 1800
 Duty Cycle Factor : 1
 Conversion Factor : 5.0
 Probe Sensitivity : 1.20 1.20 1.20 $\mu\text{V}/(\text{V/m})^2$
 Compression Point : 95.00 mV
 Offset : 1.56 mm

1 gram SAR value : 0.771 W/kg
 10 gram SAR value : 0.462 W/kg
 Area Scan Peak SAR : 0.859 W/kg
 Zoom Scan Peak SAR : 1.331 W/kg

Plot 20#

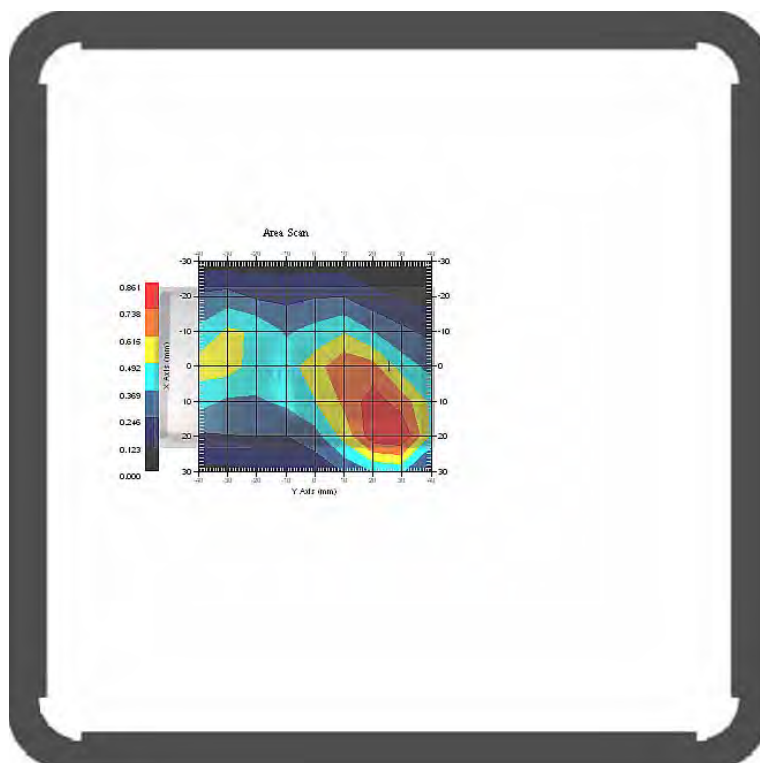

Test Laboratory: Bay Area Compliance Lab Corp. (Shenzhen)

LTE Band 4—50 RB; Body-Back (1732.5 MHz Middle Channel)

Measurement Data

Test mode : LTE
 Crest Factor : 1
 Scan Type : Complete
 Area Scan : 8x11x1: Measurement x=10mm, y=10mm, z=4mm
 Zoom Scan : 7x7x7: Measurement x=5mm, y=5mm, z=5mm
 Power Drift-Start : 1.021 W/kg
 Power Drift-Finish : 1.055 W/kg
 Power Drift (%) : 3.214

Tissue Data

Type : Body
 Frequency : 1732.50 MHz
 Epsilon : 53.76 F/m
 Sigma : 1.53 S/m
 Density : 1000.00 kg/cu. m

Probe Data

Serial No. : 500-00283
 Frequency Band : 1800
 Duty Cycle Factor : 1
 Conversion Factor : 5.0
 Probe Sensitivity : 1.20 1.20 1.20 $\mu\text{V}/(\text{V}/\text{m})^2$
 Compression Point : 95.00 mV
 Offset : 1.56 mm

1 gram SAR value : 1.024 W/kg
 10 gram SAR value : 0.446 W/kg
 Area Scan Peak SAR : 1.066 W/kg
 Zoom Scan Peak SAR : 1.351 W/kg

Plot 21#

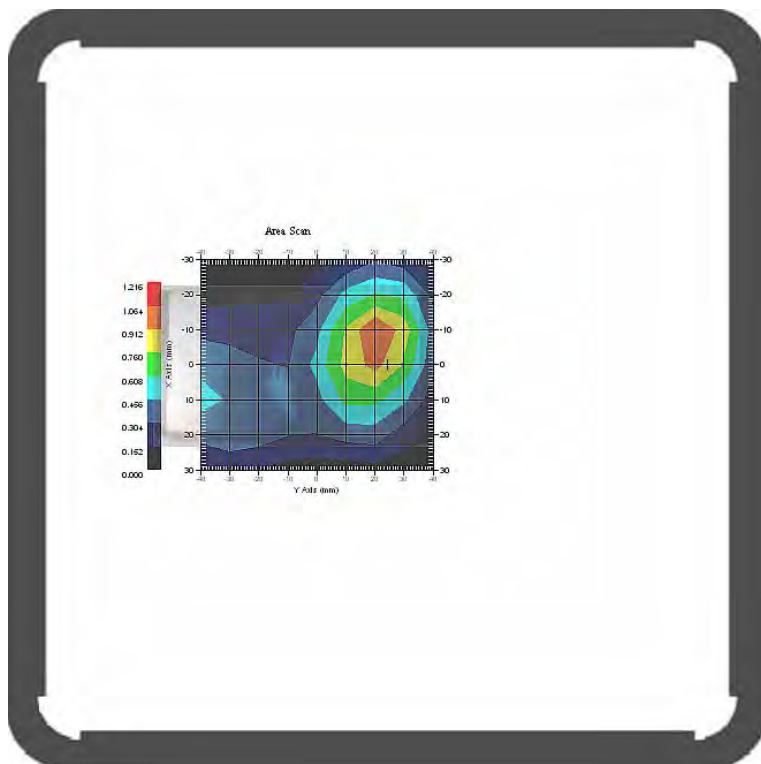

Test Laboratory: Bay Area Compliance Lab Corp. (Shenzhen)

LTE Band 4—50 RB; Body-Top (1732.5 MHz Middle Channel)

Measurement Data

Test mode : LTE
 Crest Factor : 1
 Scan Type : Complete
 Area Scan : 8x11x1: Measurement x=10mm, y=10mm, z=4mm
 Zoom Scan : 7x7x7: Measurement x=5mm, y=5mm, z=5mm
 Power Drift-Start : 0.162 W/kg
 Power Drift-Finish : 0.165 W/kg
 Power Drift (%) : 1.793

Tissue Data

Type : Body
 Frequency : 1732.50 MHz
 Epsilon : 53.76 F/m
 Sigma : 1.53 S/m
 Density : 1000.00 kg/cu. m

Probe Data

Serial No. : 500-00283
 Frequency Band : 1800
 Duty Cycle Factor : 1
 Conversion Factor : 5.0
 Probe Sensitivity : 1.20 1.20 1.20 $\mu\text{V}/(\text{V}/\text{m})^2$
 Compression Point : 95.00 mV
 Offset : 1.56 mm

1 gram SAR value : 0.179 W/kg
 10 gram SAR value : 0.101 W/kg
 Area Scan Peak SAR : 0.188 W/kg
 Zoom Scan Peak SAR : 0.301 W/kg

Plot 22#

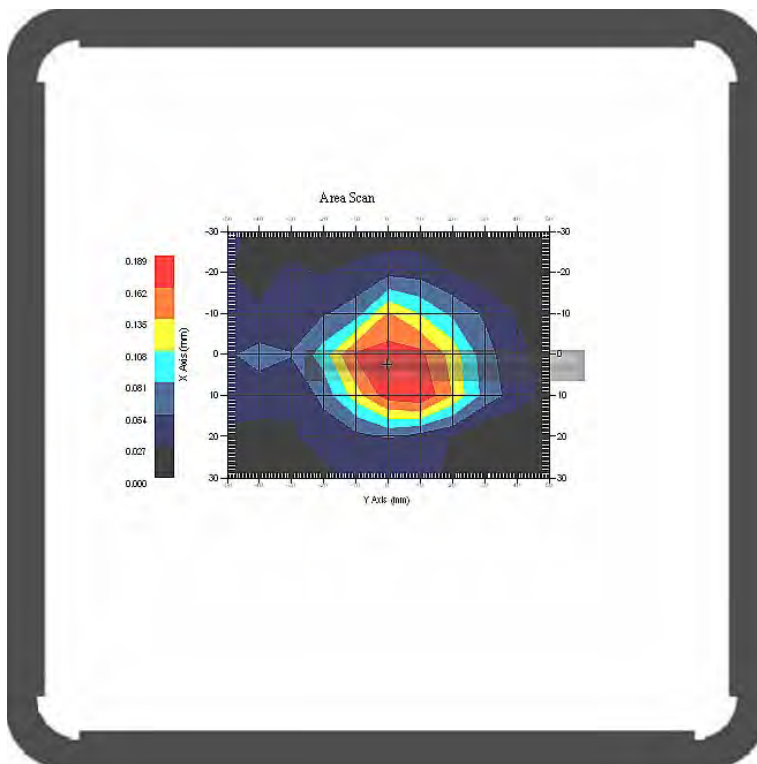

Test Laboratory: Bay Area Compliance Lab Corp. (Shenzhen)

LTE Band 4—50 RB; Body-Bottom (1732.5 MHz Middle Channel)

Measurement Data

Test mode : LTE
 Crest Factor : 1
 Scan Type : Complete
 Area Scan : 8x11x1: Measurement x=10mm, y=10mm, z=4mm
 Zoom Scan : 7x7x7: Measurement x=5mm, y=5mm, z=5mm
 Power Drift-Start : 0.122 W/kg
 Power Drift-Finish : 0.120 W/kg
 Power Drift (%) : -1.472

Tissue Data

Type : Body
 Frequency : 1732.50 MHz
 Epsilon : 53.76 F/m
 Sigma : 1.53 S/m
 Density : 1000.00 kg/cu. m

Probe Data

Serial No. : 500-00283
 Frequency Band : 1800
 Duty Cycle Factor : 1
 Conversion Factor : 5.0
 Probe Sensitivity : 1.20 1.20 1.20 $\mu\text{V}/(\text{V/m})^2$
 Compression Point : 95.00 mV
 Offset : 1.56 mm

1 gram SAR value : 0.121 W/kg
 10 gram SAR value : 0.053 W/kg
 Area Scan Peak SAR : 0.136 W/kg
 Zoom Scan Peak SAR : 0.200 W/kg

Plot 23#

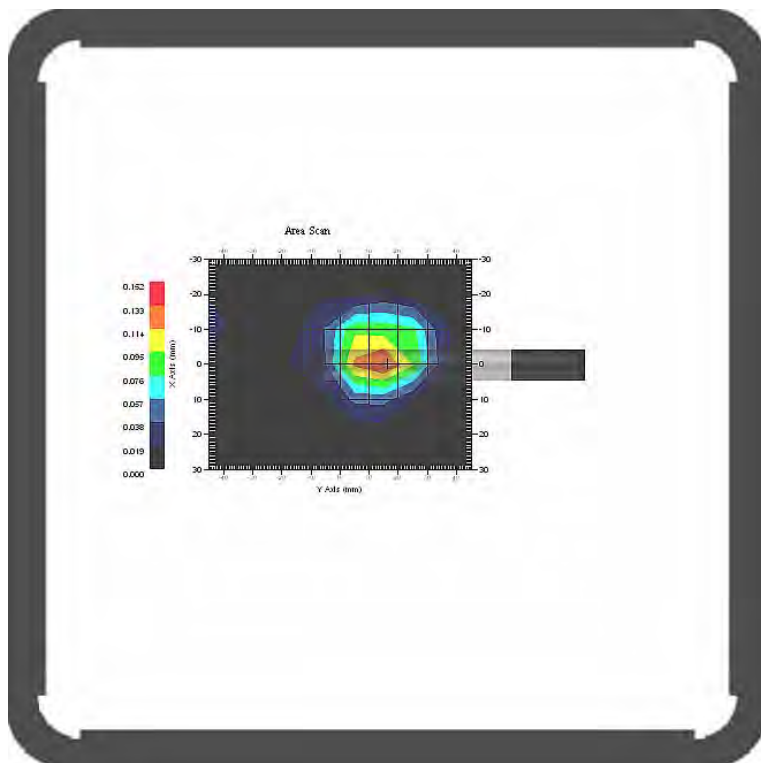

Test Laboratory: Bay Area Compliance Lab Corp. (Shenzhen)

LTE Band 4—50 RB; Body-Left (1732.5 MHz Middle Channel)

Measurement Data

Test mode : LTE
 Crest Factor : 1
 Scan Type : Complete
 Area Scan : 8x11x1: Measurement x=10mm, y=10mm, z=4mm
 Zoom Scan : 7x7x7: Measurement x=5mm, y=5mm, z=5mm
 Power Drift-Start : 0.705 W/kg
 Power Drift-Finish : 0.700 W/kg
 Power Drift (%) : -0.669

Tissue Data

Type : Body
 Frequency : 1732.50 MHz
 Epsilon : 53.76 F/m
 Sigma : 1.53 S/m
 Density : 1000.00 kg/cu. m

Probe Data

Serial No. : 500-00283
 Frequency Band : 1800
 Duty Cycle Factor : 1
 Conversion Factor : 5.0
 Probe Sensitivity : 1.20 1.20 1.20 $\mu\text{V}/(\text{V/m})^2$
 Compression Point : 95.00 mV
 Offset : 1.56 mm

1 gram SAR value : 0.699 W/kg
 10 gram SAR value : 0.368 W/kg
 Area Scan Peak SAR : 0.709 W/kg
 Zoom Scan Peak SAR : 1.311 W/kg

Plot 24#

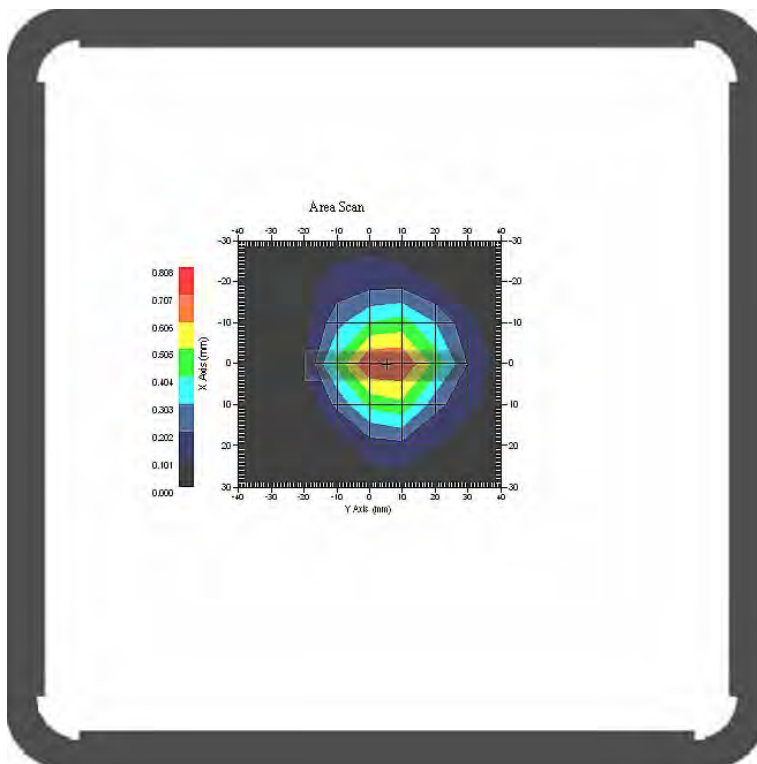

Test Laboratory: Bay Area Compliance Lab Corp. (Shenzhen)

LTE Band 4—100 RB; Body - Front (1732.5 MHz Middle Channel)

Measurement Data

Test mode : LTE
 Crest Factor : 1
 Scan Type : Complete
 Area Scan : 8x11x1: Measurement x=10mm, y=10mm, z=4mm
 Zoom Scan : 7x7x7: Measurement x=5mm, y=5mm, z=5mm
 Power Drift-Start : 1.101 W/kg
 Power Drift-Finish : 1.099 W/kg
 Power Drift (%) : -0.356

Tissue Data

Type : Body
 Frequency : 1732.50 MHz
 Epsilon : 53.76 F/m
 Sigma : 1.53 S/m
 Density : 1000.00 kg/cu. m

Probe Data

Serial No. : 500-00283
 Frequency Band : 1800
 Duty Cycle Factor : 1
 Conversion Factor : 5.0
 Probe Sensitivity : 1.20 1.20 1.20 $\mu\text{V}/(\text{V}/\text{m})^2$
 Compression Point : 95.00 mV
 Offset : 1.56 mm

1 gram SAR value : 1.126 W/kg
 10 gram SAR value : 0.779 W/kg
 Area Scan Peak SAR : 1.367 W/kg
 Zoom Scan Peak SAR : 1.871 W/kg

Plot 25#

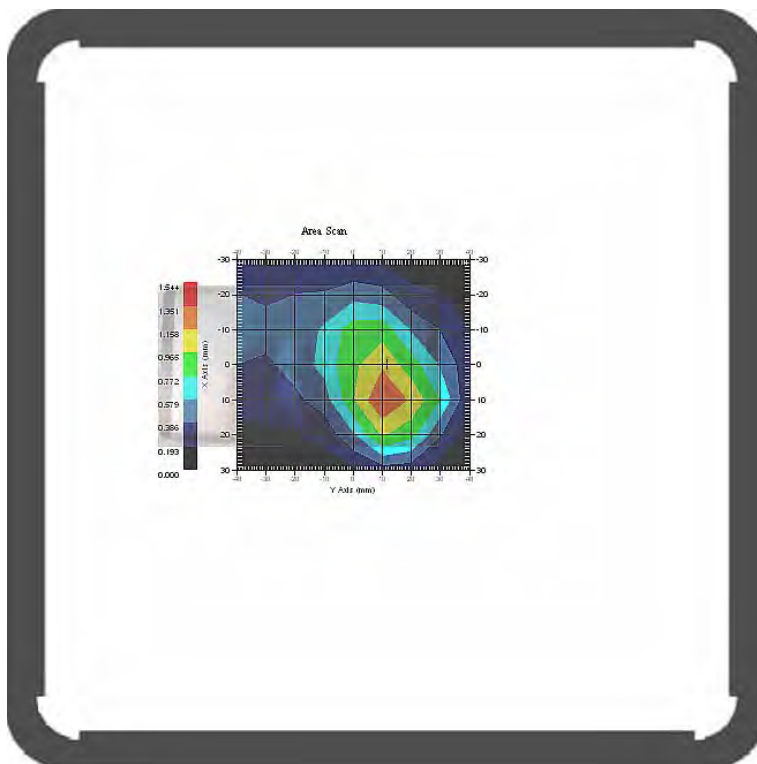

Test Laboratory: Bay Area Compliance Lab Corp. (Shenzhen)

LTE Band 4—100 RB; Body-Back (1732.5 MHz Middle Channel)

Measurement Data

Test mode : LTE
 Crest Factor : 1
 Scan Type : Complete
 Area Scan : 8x11x1: Measurement x=10mm, y=10mm, z=4mm
 Zoom Scan : 7x7x7: Measurement x=5mm, y=5mm, z=5mm
 Power Drift-Start : 0.738 W/kg
 Power Drift-Finish : 0.718 W/kg
 Power Drift (%) : -3.392

Tissue Data

Type : Body
 Frequency : 1732.50 MHz
 Epsilon : 53.76 F/m
 Sigma : 1.53 S/m
 Density : 1000.00 kg/cu. m

Probe Data

Serial No. : 500-00283
 Frequency Band : 1800
 Duty Cycle Factor : 1
 Conversion Factor : 5.0
 Probe Sensitivity : 1.20 1.20 1.20 $\mu\text{V}/(\text{V}/\text{m})^2$
 Compression Point : 95.00 mV
 Offset : 1.56 mm

1 gram SAR value : 0.837 W/kg
 10 gram SAR value : 0.529 W/kg
 Area Scan Peak SAR : 0.916 W/kg
 Zoom Scan Peak SAR : 1.274 W/kg

Plot 26#

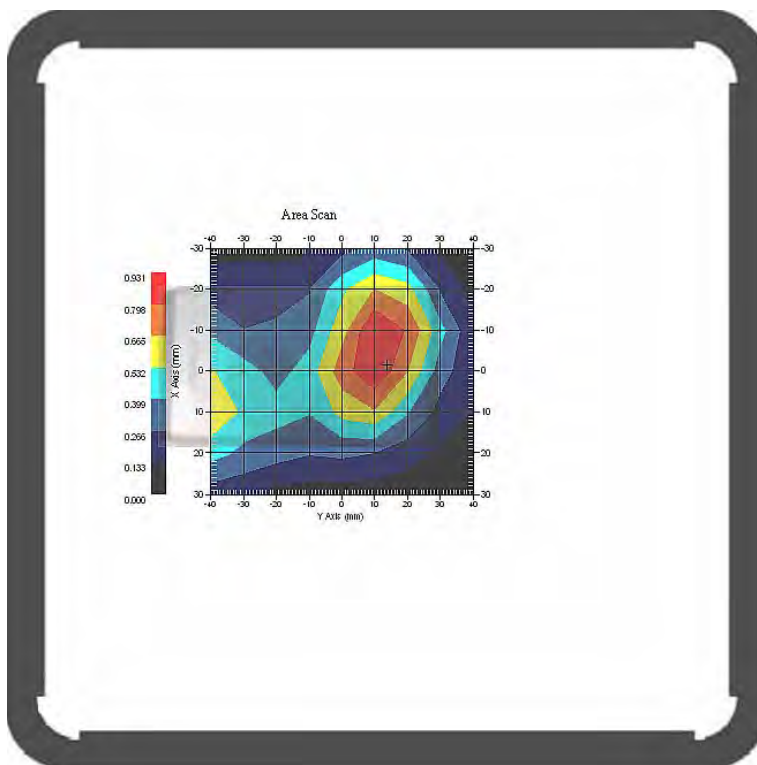

Test Laboratory: Bay Area Compliance Lab Corp. (Shenzhen)

Hot Spot: 802.11g; Body -Front (2462 MHz Channel 11)

Measurement Data

Crest Factor : 1
 Scan Type : Complete
 Area Scan : 8x11x1 : Measurement x=10mm, y=10mm, z=4mm
 Zoom Scan : 7x7x7 : Measurement x=5mm, y=5mm, z=5mm
 Power Drift-Start : 0.035 W/kg
 Power Drift-Finish : 0.035 W/kg
 Power Drift (%) : -1.231

Tissue Data

Type : Body
 Frequency : 2462 MHz
 Epsilon : 52.41 F/m
 Sigma : 1.98 S/m
 Density : 1000.00 kg/cu. m

Probe Data

Serial No. : 500-00283
 Frequency Band : 2450
 Duty Cycle Factor : 1
 Conversion Factor : 4.3
 Probe Sensitivity : 1.20 1.20 1.20 $\mu\text{V}/(\text{V}/\text{m})^2$
 Compression Point : 95.00 mV
 Offset : 1.56 mm

1 gram SAR value : 0.110 W/kg
 10 gram SAR value : 0.036 W/kg
 Area Scan Peak SAR : 0.095 W/kg
 Zoom Scan Peak SAR : 0.270 W/kg

Plot 27#

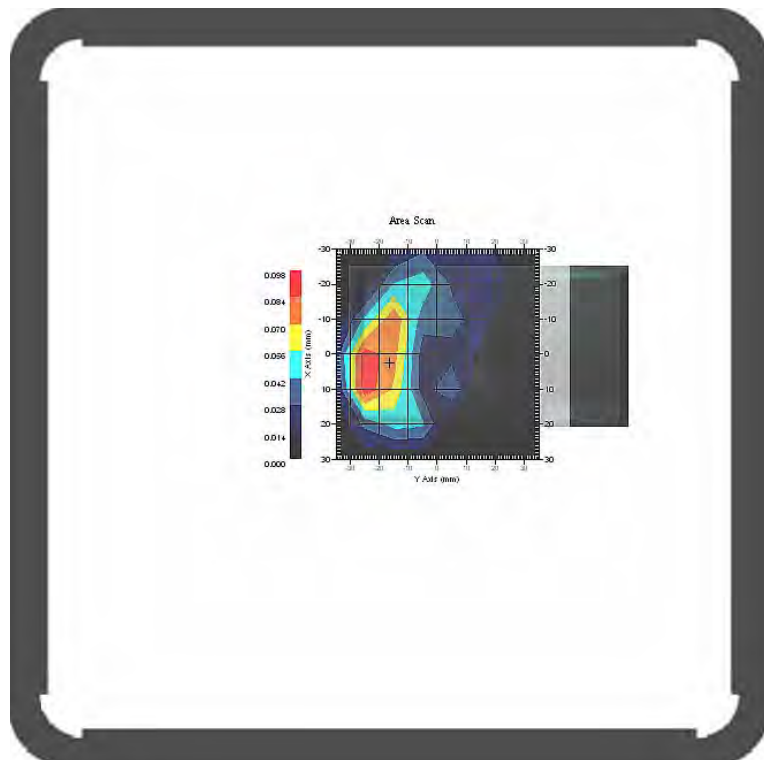

Test Laboratory: Bay Area Compliance Lab Corp. (Shenzhen)

Hot Spot: 802.11g; Body-Back (2462 MHz Channel 11)

Measurement Data

Crest Factor : 1
 Scan Type : Complete
 Area Scan : 8x11x1 : Measurement x=10mm, y=10mm, z=4mm
 Zoom Scan : 7x7x7 : Measurement x=5mm, y=5mm, z=5mm
 Power Drift-Start : 0.014 W/kg
 Power Drift-Finish : 0.014 W/kg
 Power Drift (%) : 0.892

Tissue Data

Type : Body
 Frequency : 2462 MHz
 Epsilon : 52.41 F/m
 Sigma : 1.98 S/m
 Density : 1000.00 kg/cu. m

Probe Data

Serial No. : 500-00283
 Frequency Band : 2450
 Duty Cycle Factor : 1
 Conversion Factor : 4.3
 Probe Sensitivity : 1.20 1.20 1.20 $\mu\text{V}/(\text{V}/\text{m})^2$
 Compression Point : 95.00 mV
 Offset : 1.56 mm

1 gram SAR value : 0.021 W/kg
 10 gram SAR value : 0.007 W/kg
 Area Scan Peak SAR : 0.026 W/kg
 Zoom Scan Peak SAR : 0.080 W/kg

Plot 28#

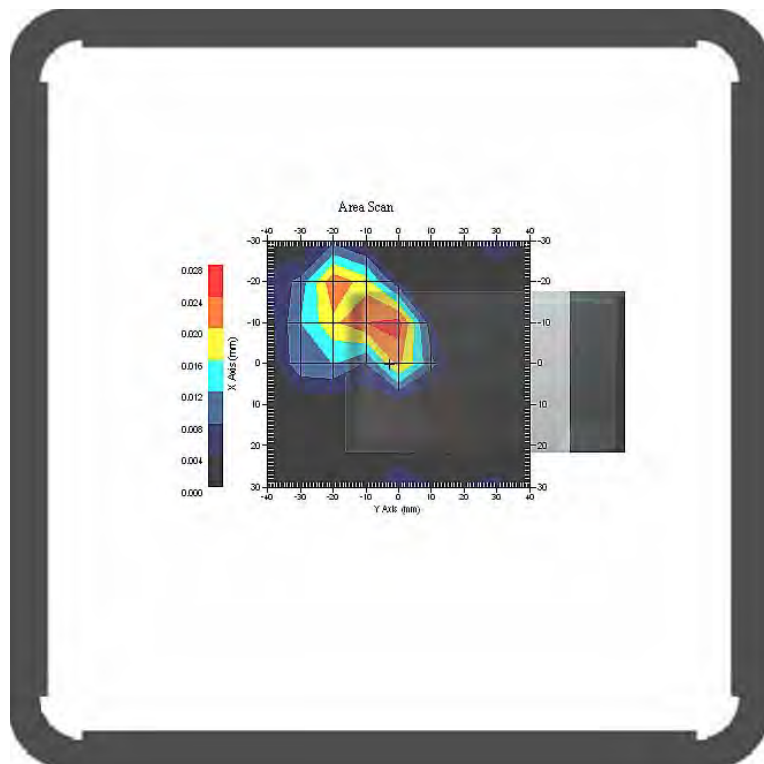

Test Laboratory: Bay Area Compliance Lab Corp. (Shenzhen)

Hot Spot: 802.11g; Body-Bottom (2462 MHz Channel 11)

Measurement Data

Crest Factor : 1
 Scan Type : Complete
 Area Scan : 8x11x1 : Measurement x=10mm, y=10mm, z=4mm
 Zoom Scan : 7x7x7 : Measurement x=5mm, y=5mm, z=5mm
 Power Drift-Start : 0.001 W/kg
 Power Drift-Finish : 0.001 W/kg
 Power Drift (%) : 2.014

Tissue Data

Type : Body
 Frequency : 2462 MHz
 Epsilon : 52.41 F/m
 Sigma : 1.98 S/m
 Density : 1000.00 kg/cu. m

Probe Data

Serial No. : 500-00283
 Frequency Band : 2450
 Duty Cycle Factor : 1
 Conversion Factor : 4.3
 Probe Sensitivity : 1.20 1.20 1.20 $\mu\text{V}/(\text{V}/\text{m})^2$
 Compression Point : 95.00 mV
 Offset : 1.56 mm

1 gram SAR value : 0.004 W/kg
 10 gram SAR value : 0.002 W/kg
 Area Scan Peak SAR : 0.010 W/kg
 Zoom Scan Peak SAR : 0.050 W/kg

Plot 29#

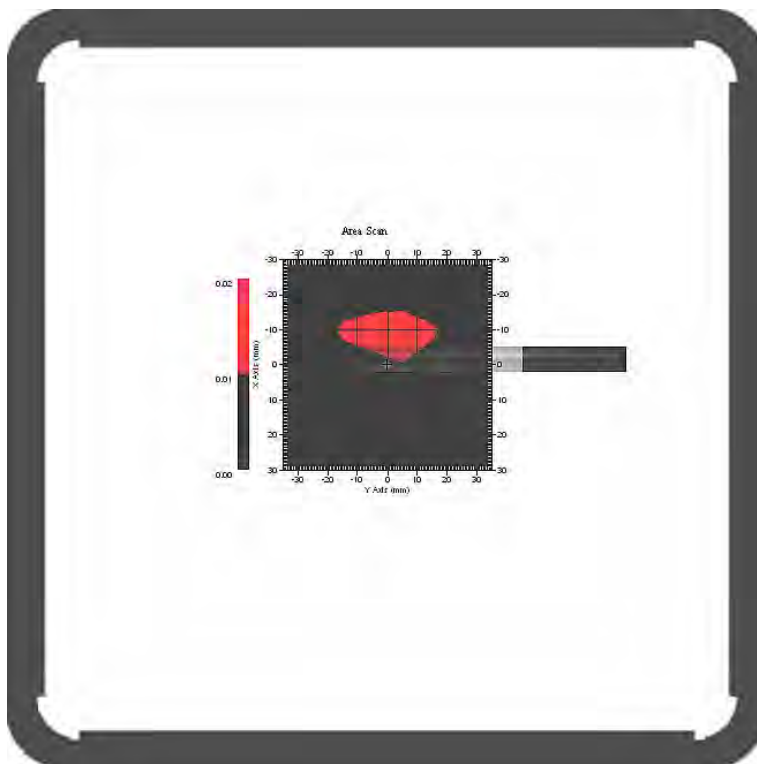

Test Laboratory: Bay Area Compliance Lab Corp. (Shenzhen)

Hot Spot: 802.11g; Body-Right (2462 MHz Channel 11)

Measurement Data

Crest Factor : 1
Scan Type : Complete
Area Scan : 8x11x1 : Measurement x=10mm, y=10mm, z=4mm
Zoom Scan : 7x7x7 : Measurement x=5mm, y=5mm, z=5mm
Power Drift-Start : 0.001 W/kg
Power Drift-Finish : 0.001 W/kg
Power Drift (%) : -3.241

Tissue Data

Type : Body
Frequency : 2462 MHz
Epsilon : 52.41 F/m
Sigma : 1.98 S/m
Density : 1000.00 kg/cu. m

Probe Data

Serial No. : 500-00283
Frequency Band : 2450
Duty Cycle Factor : 1
Conversion Factor : 4.3
Probe Sensitivity : 1.20 1.20 1.20 $\mu\text{V}/(\text{V}/\text{m})^2$
Compression Point : 95.00 mV
Offset : 1.56 mm

1 gram SAR value : 0.039 W/kg
10 gram SAR value : 0.017 W/kg
Area Scan Peak SAR : 0.066 W/kg
Zoom Scan Peak SAR : 0.110 W/kg

Plot 30#

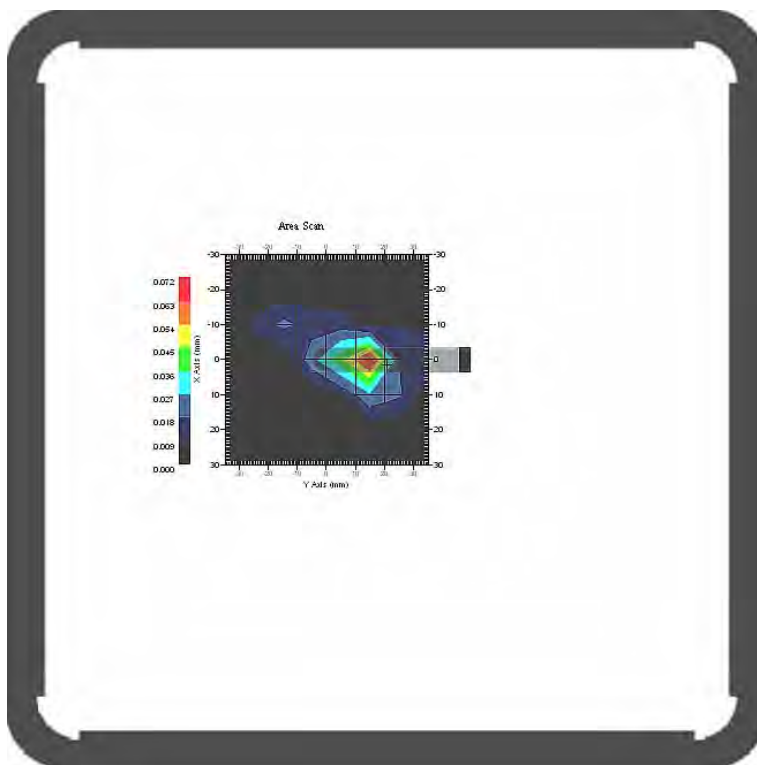

APPENDIX A – MEASUREMENT UNCERTAINTY

The uncertainty budget has been determined for the measurement system and is given in the following Table.

Measurement Uncertainty for 300MHz to 3GHz

Source of Uncertainty	Tolerance Value	Probability Distribution	Divisor	c_i^1 (1-g)	c_i^1 (10-g)	Standard Uncertainty (1-g) %	Standard Uncertainty (10-g) %
Measurement System							
Probe Calibration	3.5	normal	1	1	1	3.5	3.5
Axial Isotropy	3.7	rectangular	$\sqrt{3}$	$(1-cp)^{1/2}$	$(\frac{1-cp}{2})^{1/2}$	1.5	1.5
Hemispherical Isotropy	10.9	rectangular	$\sqrt{3}$	\sqrt{cp}	\sqrt{cp}	4.4	4.4
Boundary Effect	1.0	rectangular	$\sqrt{3}$	1	1	0.6	0.6
Linearity	4.7	rectangular	$\sqrt{3}$	1	1	2.7	2.7
Detection Limit	1.0	rectangular	$\sqrt{3}$	1	1	0.6	0.6
Readout Electronics	1.0	normal	1	1	1	1.0	1.0
Response Time	0.8	rectangular	$\sqrt{3}$	1	1	0.5	0.5
Integration Time	1.7	rectangular	$\sqrt{3}$	1	1	1.0	1.0
RF Ambient Condition -Noise	0.006	rectangular	$\sqrt{3}$	1	1	0.003	0.003
RF Ambient Condition - Reflections	3.0	rectangular	$\sqrt{3}$	1	1	1.7	1.7
Probe Positioner Mech. Restrictions	0.4	rectangular	$\sqrt{3}$	1	1	0.2	0.2
Restriction							
Probe Positioning with respect to Phantom Shell	2.9	rectangular	$\sqrt{3}$	1	1	1.7	1.7
Extrapolation and Integration	3.7	rectangular	$\sqrt{3}$	1	1	2.1	2.1
Test Sample Positioning	0.023	normal	1	1	1	0.023	0.023
Device Holder Uncertainty	6.215	normal	1	1	1	6.215	6.215
Drift of Output Power	4.627	rectangular	$\sqrt{3}$	1	1	2.67	2.67
Phantom and Setup							
Phantom Uncertainty(shape & thickness tolerance)	3.4	rectangular	$\sqrt{3}$	1	1	2.0	2.0
Liquid Conductivity(target)	5.0	rectangular	$\sqrt{3}$	0.7	0.5	2.0	1.4
Liquid Conductivity(meas.)	1.938	normal	1	0.7	0.5	1.36	0.97
Liquid Permittivity(target)	5.0	rectangular	$\sqrt{3}$	0.6	0.5	1.7	1.4
Liquid Permittivity(meas.)	3.093	normal	1	0.6	0.5	1.86	1.55
Combined Uncertainty		RSS				10.78	10.55
Expanded uncertainty (coverage factor=2)		Normal(k=2)				21.56	21.10

APPENDIX B – PROBE CALIBRATION CERTIFICATES

NCL CALIBRATION LABORATORIES

Calibration File No.: 1427-1430

Client.: BACL Lab

CERTIFICATE OF CALIBRATION

It is certified that the equipment identified below has been calibrated in the **NCL CALIBRATION LABORATORIES** by qualified personnel following recognized procedures and using transfer standards traceable to NRC/NIST.

Equipment: Miniature Isotropic RF Probe

Record of Calibration

Head and Body

Manufacturer: APREL Laboratories

Model No.: E-020

Serial No.: 500-00283

Calibration Procedure: D01-032-E020-V2, D22-012-Tissue, D28-002-Dipole
Project No: BACL-5673

Calibrated: 8th August 2012
Released on: 9th August 2012

This Calibration Certificate is Incomplete Unless Accompanied with the Calibration Results Summary

Released By: _____



Art Brennan, Quality Manager

NCL CALIBRATION LABORATORIES

Suite 102, 303 Terry Fox Dr,
OTTAWA, ONTARIO
CANADA K2K 3J1

Division of APREL Lab.
TEL: (613) 435-8300
FAX: (613) 435-8306

NCL Calibration Laboratories

Division of APREL Inc.

Introduction

This Calibration Report reproduces the results of the calibration performed in line with the references listed below. Calibration is performed using accepted methodologies as per the references listed below. Probes are calibrated for air, and tissue and the values reported are the results from the physical quantification of the probe through meteorological practices.

Calibration Method

Probes are calibrated using the following methods.

<1000MHz

TEM Cell for sensitivity in air

Standard phantom using temperature transfer method for sensitivity in tissue

>1000MHz

Waveguide* method to determine sensitivity in air and tissue

*Waveguide is numerically (simulation) assessed to determine the field distribution and power

The boundary effect for the probe is assessed using a standard flat phantom where the probe output is compared against a numerically simulated series of data points

References

- IEEE Standard 1528 (2003) including Amendment 1
IEEE Recommended Practice for Determining the Peak Spatial-Average Specific Absorption Rate (SAR) in the Human Head from Wireless Communications Devices: Measurement Techniques
- EN 62209-1 (2006)
Human Exposure to RF Fields from hand-held and body-mounted wireless communication devices - Human models, instrumentation, and procedures-Part 1: Procedure to measure the Specific Absorption Rate (SAR) for hand-held mobile wireless devices
- IEC 62209-2 Ed. 1.0 (2010-03)
Human exposure to RF fields from hand-held and body-mounted wireless devices - Human models, instrumentation, and procedures - Part 2: specific absorption rate (SAR) for wireless communication devices (30 MHz - 6 GHz)
- TP-D01-032-E020-V2 E-Field probe calibration procedure
- D22-012-Tissue dielectric tissue calibration procedure
- D28-002-Dipole procedure for validation of SAR system using a dipole
- IEEE 1309 Draft Standard for Calibration of Electromagnetic Field Sensors and Probes, Excluding Antennas, from 9kHz to 40GHz

Page 2 of 10

This page has been reviewed for content and attested to on Page 2 of this document.

NCL Calibration Laboratories

Division of APREL Inc.

Conditions

Probe 500-00283 was a recalibration with the exception frequency of 450 MHz .which was a new calibration

Ambient Temperature of the Laboratory: 22 °C +/- 1.5°C
Temperature of the Tissue: 21 °C +/- 1.5°C
Relative Humidity: < 60%

Primary Measurement Standards

Instrument	Serial Number	Cal due date
Power meter Anritsu MA2408A	90025437	Nov.4, 2012
Power Sensor Anritsu MA2481D	103555	Nov 4, 2012
Attenuator HP 8495A (70dB)	1944A10711	Sept. 14, 2012
Network Analyzer Anritsu MT8801C	MB11855	Feb. 8, 2013

Secondary Measurement Standards

Signal Generator Agilent E4438C -506 MY55182336 June 7, 2013

Attestation

The below named signatories have conducted the calibration and review of the data which is presented in this calibration report.

We the undersigned attest that to the best of our knowledge the calibration of this subject has been accurately conducted and that all information contained within the results pages have been reviewed for accuracy.

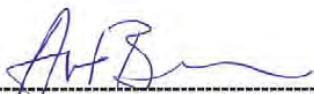

Art Brennan, Quality Manager



Dan Brooks, Test Engineer

Page 3 of 10
This page has been reviewed for content and attested to on Page 2 of this document.

NCL Calibration Laboratories

Division of APREL Inc.

Probe Summary

Probe Type:	E-Field Probe E020
Serial Number:	500-00283
Frequency:	As presented on page 5
Sensor Offset:	1.56
Sensor Length:	2.5
Tip Enclosure:	Composite*
Tip Diameter:	< 2.9 mm
Tip Length:	55 mm
Total Length:	289 mm

*Resistive to recommended tissue recipes per IEEE-1528

Sensitivity in Air

Channel X:	1.2 $\mu\text{V}/(\text{V}/\text{m})^2$
Channel Y:	1.2 $\mu\text{V}/(\text{V}/\text{m})^2$
Channel Z:	1.2 $\mu\text{V}/(\text{V}/\text{m})^2$
Diode Compression Point:	95 mV

NCL Calibration Laboratories

Division of APREL Inc.

Calibration for Tissue (Head H, Body B)

Frequency	Tissue Type	Measured Epsilon	Measured Sigma	Calibration Uncertainty	Tolerance Uncertainty for 5%*	Conversion Factor
450 H	Head	43.98	0.9	3.5	3.4	6
450 B	Body	57.07	0.92	3.5	3.4	6
750 H	Head	X	X	X	X	X
750 B	Body	X	X	X	X	X
835 H	Head	42.35	0.938	3.5	3.4	6.6
835 B	Body	56.65	1.018	3.5	3.4	6.6
900 H	Head	41.35	0.98	3.5	3.4	6
900 B	Body	56.08	1.05	3.5	3.4	6
1450 H	Head	X	X	X	X	X
1450 B	Body	X	X	X	X	X
1500 H	Head	X	X	X	X	X
1500 B	Body	X	X	X	X	X
1640 H	Head	X	X	X	X	X
1640 B	Body	X	X	X	X	X
1750 H	Head	38.72	1.35	3.5	3.4	5.1
1750 B	Body	51.62	1.48	3.5	3.4	4.8
1800 H	Head	X	X	X	X	X
1800 B	Body	X	X	X	X	X
1900 H	Head	38.72	1.35	3.5	2.7	5.2
1900 B	Body	51.62	1.48	3.5	2.7	5
2000 H	Head	X	X	X	X	X
2000 B	Body	X	X	X	X	X
2100 H	Head	X	X	X	X	X
2100 B	Body	X	X	X	X	X
2300 H	Head	X	X	X	X	X
2300 B	Body	X	X	X	X	X
2450 H	Head	38.06	1.87	3.5	3.5	4.9
2450 B	Body	50.22	2.03	3.5	3.5	4.3
2600 H	Head	X	X	X	X	X
2600 B	Body	X	X	X	X	X
3000 H	Head	X	X	X	X	X
3000 B	Body	X	X	X	X	X
3600 H	Head	X	X	X	X	X
3600 B	Body	X	X	X	X	X
5200 H	Head	X	X	X	X	X
5200 B	Body	X	X	X	X	X
5600 H	Head	X	X	X	X	X
5600 B	Body	X	X	X	X	X
5800 H	Head	X	X	X	X	X
5800 B	Body	X	X	X	X	X

NCL Calibration Laboratories

Division of APREL Inc.

Boundary Effect:

Uncertainty resulting from the boundary effect is less than 2.1% for the distance between the tip of the probe and the tissue boundary, when less than 0.58mm.

Spatial Resolution:

The spatial resolution uncertainty is less than 1.5% for 4.9mm diameter probe.
The spatial resolution uncertainty is less than 1.0% for 2.5mm diameter probe.

DAQ-PAQ Contribution

To minimize the uncertainty calculation all tissue sensitivity values were calculated using a load impedance of 5 MΩ.

Boundary Effect:

For a distance of 0.58mm the worst case evaluated uncertainty (increase in the probe sensitivity) is less than 2.1%.

NOTES:

*The maximum deviation from the centre frequency when comparing the lower to upper range is listed.

Page 6 of 10

This page has been reviewed for content and attested to on Page 2 of this document.

NCL Calibration Laboratories

Division of APREL Inc.

Receiving Pattern Air

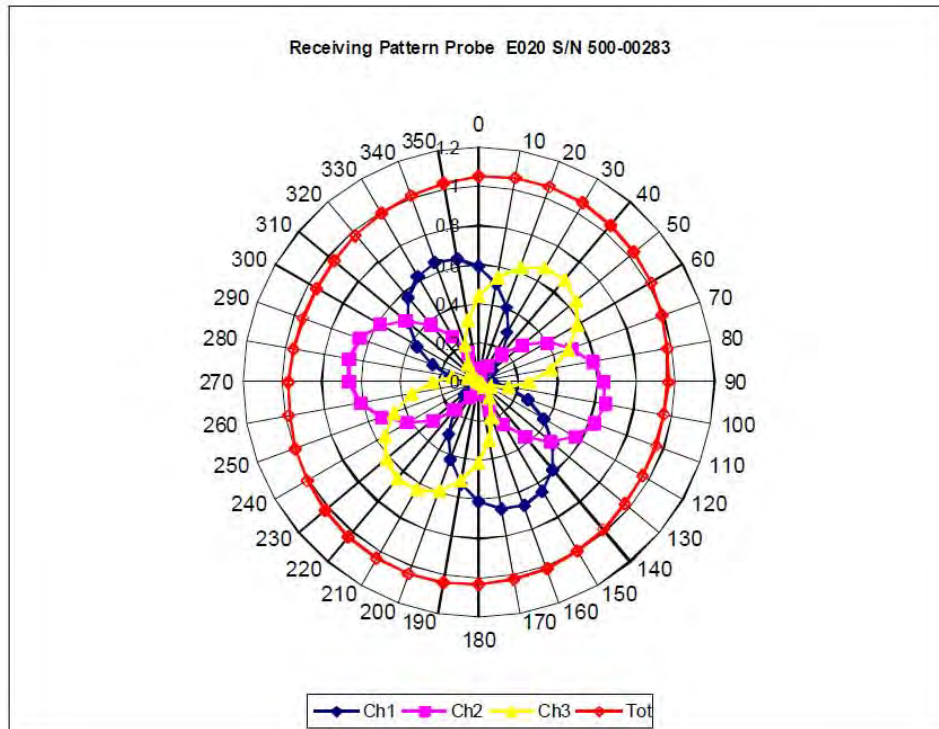

Page 7 of 10

This page has been reviewed for content and attested to on Page 2 of this document.

NCL Calibration Laboratories

Division of APREL Inc.

Isotropy Error Air

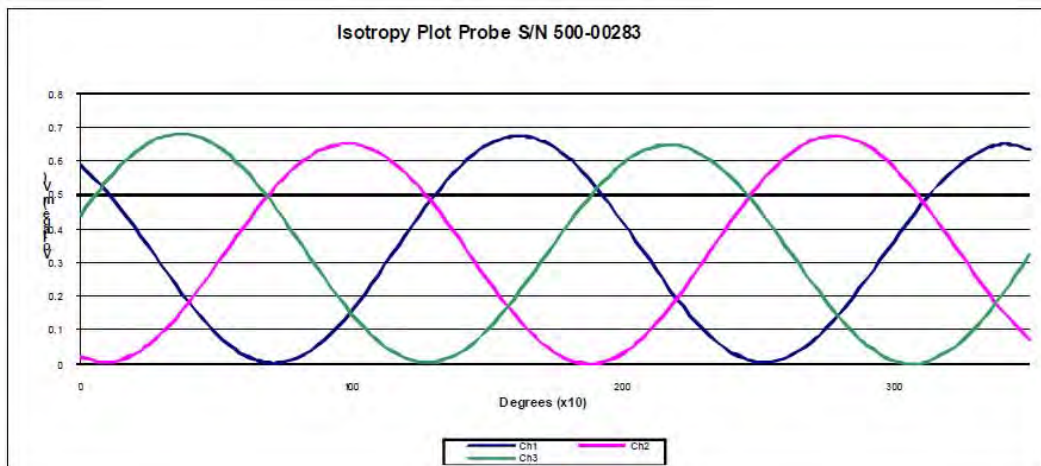
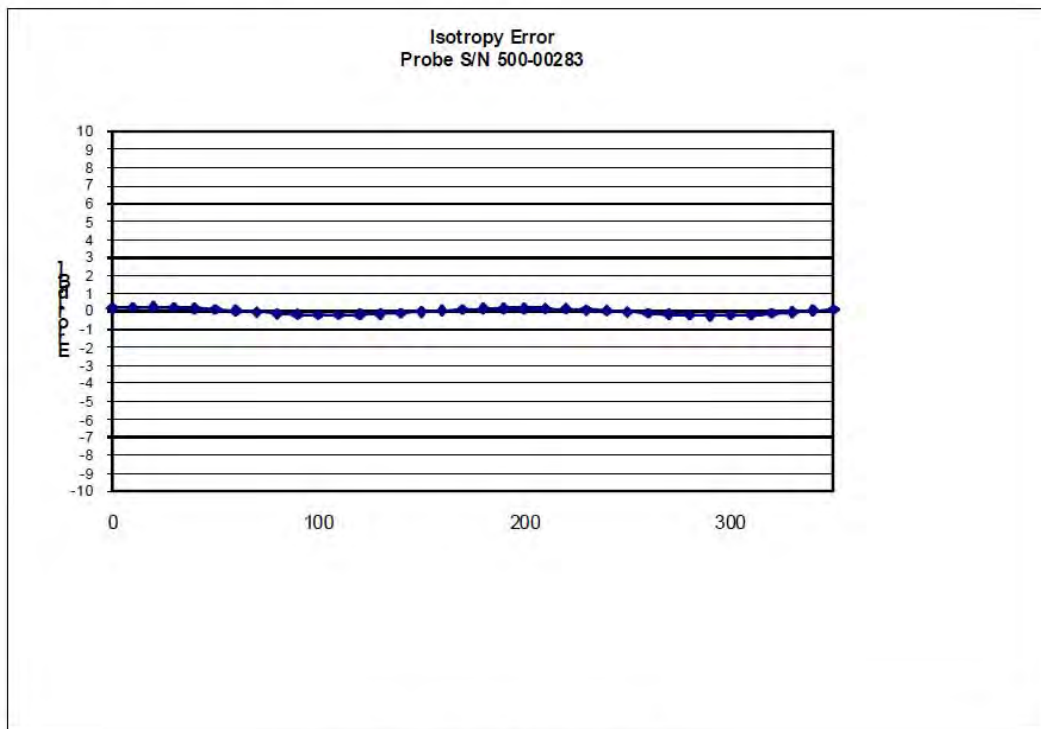

Isotropy Tissue:

0.10 dB

NCL Calibration Laboratories

Division of APREL Inc.

Dynamic Range

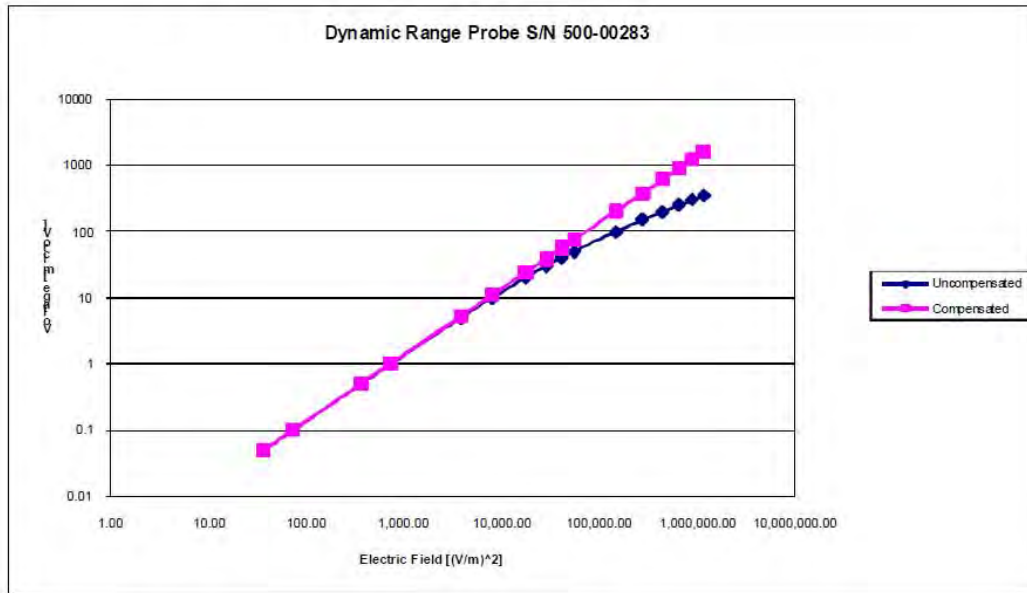

NCL Calibration Laboratories

Division of APREL Inc.

Video Bandwidth

Probe Frequency Characteristics

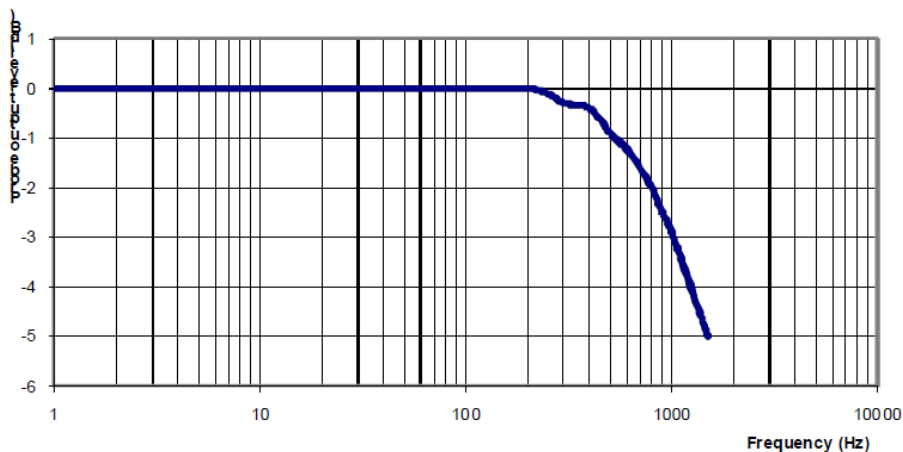

Video Bandwidth at 500 Hz 1 dB
Video Bandwidth at 1.02 KHz: 3 dB

Test Equipment

The test equipment used during Probe Calibration, manufacturer, model number and, current calibration status are listed and located on the main APREL server R:\NCL\Calibration Equipment\Instrument List May 2012.

APPENDIX C – DIPOLE CALIBRATION CERTIFICATES

NCL CALIBRATION LABORATORIES

Calibration File No: DC-1327
Project Number: BAC-dipole-cal-5618

CERTIFICATE OF CALIBRATION

It is certified that the equipment identified below has been calibrated in the
NCL CALIBRATION LABORATORIES by qualified personnel following recognized
procedures and using transfer standards traceable to NRC/NIST.

Validation Dipole(Head and Body)

Manufacturer: APREL Laboratories
Part number: ALS-D-835-S-2
Frequency: 835 MHz
Serial No: 180-00558

Customer: Bay Area Compliance Laboratory

Calibrated: 25th August 2011
Released on: 25th August 2011

This Calibration Certificate is Incomplete Unless Accompanied with the Calibration Results Summary

Released By: _____

NCL CALIBRATION LABORATORIES

Suite 102, 303 Terry Fox Dr.
Kanata, ONTARIO
CANADA K2K 3J1

Division of APREL Lab.
TEL: (613) 435-8300
FAX: (613)435-8306

NCL Calibration Laboratories

Division of APREL Laboratories.

Conditions

Dipole 180-00558 was received in good condition and a re-calibration.

Ambient Temperature of the Laboratory: 22 °C +/- 0.5°C

Temperature of the Tissue: 21 °C +/- 0.5°C

We the undersigned attest that to the best of our knowledge the calibration of this device has been accurately conducted and that all information contained within this report has been reviewed for accuracy.



Stuart Nicol



C. Teodorian

Primary Measurement Standards Instrument	Serial Number	Cal due date
Power meter Anritsu MA2408A	245025437	Nov.4, 2011
Power Sensor Anritsu MA2481D	103555	Nov 4, 2011
Attenuator HP 8495A (70dB) 1	944A10711	Aug.8, 2012
Network Analyzer Agilent E5071C	1334746J	Feb. 8, 2012
Secondary Measurement Standards		
Signal Generator Agilent E4438C	-506 MY55182336	June 7, 2012

This page has been reviewed for content and attested to by signature within this document.

NCL Calibration Laboratories

Division of APREL Laboratories.

Calibration Results Summary

The following results relate the Calibrated Dipole and should be used as a quick reference for the user.

Mechanical Dimensions

Length: 162.2 mm
Height: 89.4 mm

Electrical Specification

Tissue	Frequency	SWR:	Return Loss	Impedance
Head	835 MHz	1.0417 U	-35.395dB	49.020 Ω
Body	835 MHz	1.1177 U	-25.424dB	55.435 Ω

System Validation Results

Tissue	Frequency	1 Gram	10 Gram	Peak
Head	835 MHz	9.590	6.003	15.013
Body	835 MHz	9.684	6.263	14.23

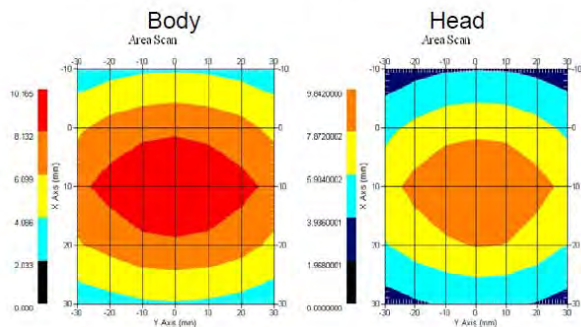

This page has been reviewed for content and attested to by signature within this document.

NCL Calibration Laboratories

Division of APREL Laboratories.

Introduction

This Calibration Report has been produced in line with the SSI Dipole Calibration Procedure SSI-TP-018-ALSAS. The results contained within this report are for Validation Dipole 180-00558. The calibration routine consisted of a three-step process. Step 1 was a mechanical verification of the dipole to ensure that it meets the mechanical specifications. Step 2 was an Electrical Calibration for the Validation Dipole, where the SWR, Impedance, and the Return loss were assessed. Step 3 involved a System Validation using the ALSAS-10U, along with APREL E-020 130 MHz to 26 GHz E-Field Probe Serial Number 212.

References

SSI-TP-018-ALSAS Dipole Calibration Procedure
 SSI-TP-016 Tissue Calibration Procedure
 IEEE 1528 "Recommended Practice for Determining the Peak Spatial-Average Specific Absorption Rate (SAR) in the Human Body Due to Wireless Communications Devices: Experimental Techniques"

Conditions

Dipole 180-00558 was new taken from stock.

Ambient Temperature of the Laboratory: 22 °C +/- 0.5°C
Temperature of the Tissue: 20 °C +/- 0.5°C

Dipole Calibration uncertainty

The calibration uncertainty for the dipole is made up of various parameters presented below.

Mechanical	1%
Positioning Error	1.22%
Electrical	1.7%
Tissue	2.2%
Dipole Validation	2.2%
TOTAL	8.32% (16.64% K=2)

This page has been reviewed for content and attested to by signature within this document.

NCL Calibration Laboratories

Division of APREL Laboratories.

Dipole Calibration Results

Mechanical Verification

APREL Length	APREL Height	Measured Length	Measured Height
161.0 mm	89.8 mm	162.2 mm	89.4 mm

Tissue Type	Return Loss:	SWR:	Impedance:
Head	-35.395 dB	1.0417 U	49.020Ω
Body	-25.454 dB	1.1177 U	55.435Ω

Tissue Validation

	Dielectric constant, ϵ_r	Conductivity, σ [S/m]
Head Tissue 835MHz	41.78	0.92
Body Tissue 835MHz	56.37	0.95

This page has been reviewed for content and attested to by signature within this document.

NCL Calibration Laboratories

Division of APREL Laboratories.

The Following Graphs are the results as displayed on the Vector Network Analyzer.

S11 Parameter Return Loss

Head Tissue

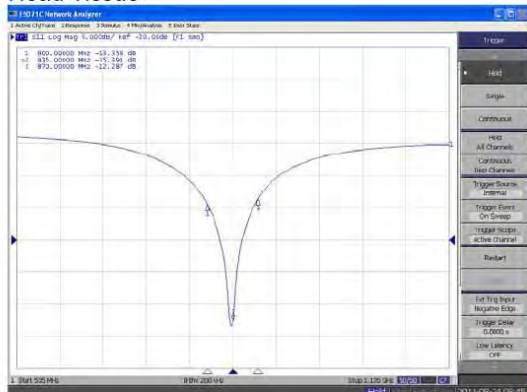

Body Tissue

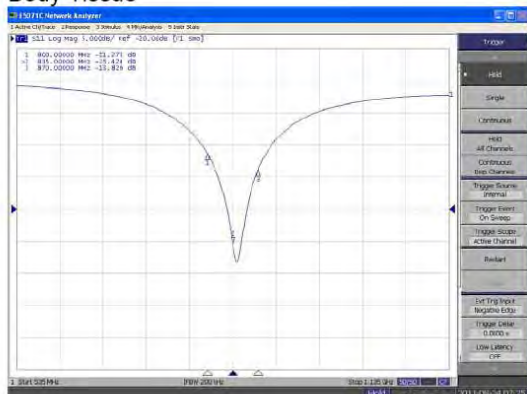

This page has been reviewed for content and attested to by signature within this document.

NCL Calibration Laboratories

Division of APREL Laboratories.

**SWR
Head**

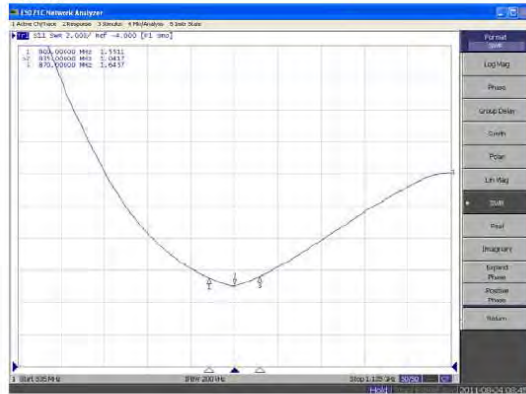

Body

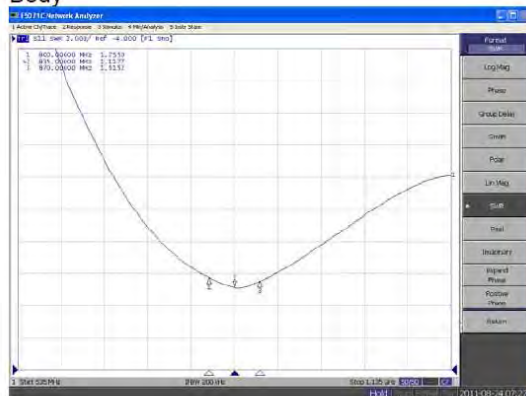

This page has been reviewed for content and attested to by signature within this document.

NCL Calibration Laboratories

Division of APREL Laboratories.

Smith Chart Dipole Impedance

Head

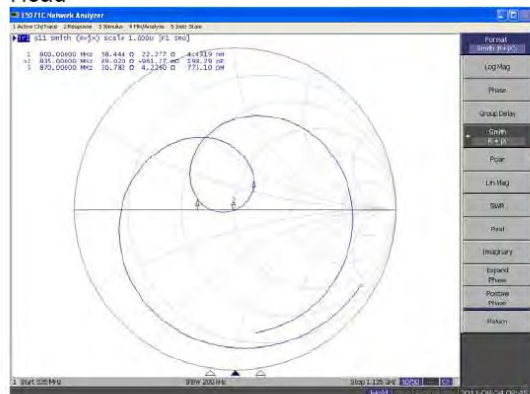

Body

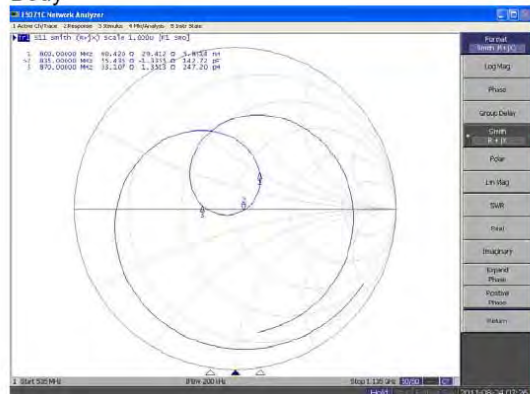

This page has been reviewed for content and attested to by signature within this document.

NCL Calibration Laboratories

Division of APREL Laboratories.

Test Equipment

The test equipment used during Probe Calibration, manufacturer, model number and, current calibration status are listed and located on the main APREL server R:\NCL\Calibration Equipment\Instrument List 2011.

This page has been reviewed for content and attested to by signature within this document.

9

835MHz Dipole Calibration By BACL at 2012-12-12

Mechanical Verification

APREL Length	APREL Height	Measured Length	Measured Height
161.0 mm	89.8 mm	161.2 mm	89.5 mm

Tissue Type	Measured Return Loss	Measured Impedance
Head	-36.177 dB	50.207 Ω
Body	-24.964 dB	49.594 Ω

Test Graphs:

Head Tissue

Return Loss :

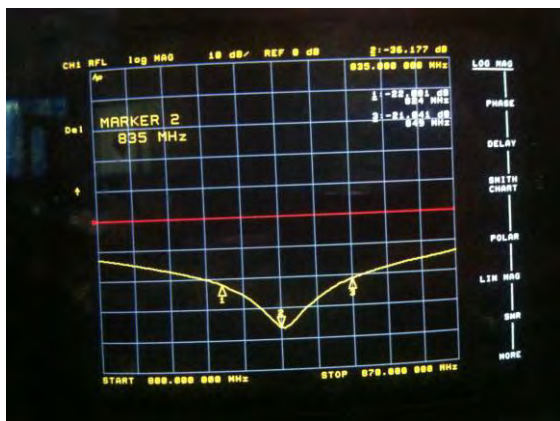

Impedance :



Body Tissue

Return Loss :

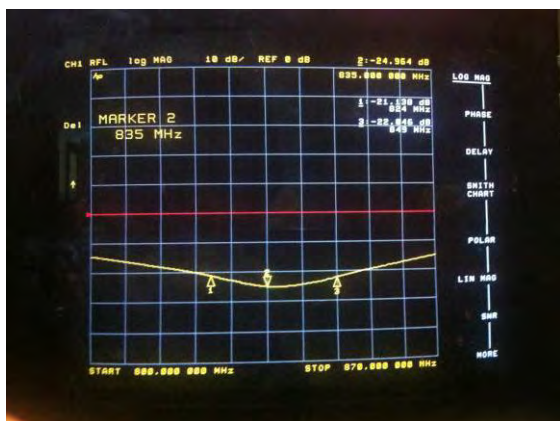

Impedance :



NCL CALIBRATION LABORATORIES

Calibration File No: DC-1329
Project Number: BAC-dipole-cal-5616

CERTIFICATE OF CALIBRATION

It is certified that the equipment identified below has been calibrated in the **NCL CALIBRATION LABORATORIES** by qualified personnel following recognized procedures and using transfer standards traceable to NRC/NIST.

Validation Dipole (Head)

Manufacturer: APREL Laboratories
Part number: ALS-D-1800-S-2
Frequency: 1800 MHz
Serial No: 200-00659

Customer: Bay Area Compliance Laboratory

Calibrated: 25th August 2011
Released on: 25th August 2011

This Calibration Certificate is Incomplete Unless Accompanied with the Calibration Results Summary

Released By: _____

NCL CALIBRATION LABORATORIES

Suit 102, 303 Terry Fox Dr.
Kanata, ONTARIO
CANADA K2K 3J1

Division of APREL Lab.
TEL: (613) 435-8300
FAX: (613) 432-8306

NCL Calibration Laboratories

Division of APREL Laboratories.

Conditions

Dipole 200-00659 was received in good condition and was a re-calibration.

Ambient Temperature of the Laboratory: 22 °C +/- 0.5°C

Temperature of the Tissue: 21 °C +/- 0.5°C

We the undersigned attest that to the best of our knowledge the calibration of this device has been accurately conducted and that all information contained within this report has been reviewed for accuracy.



Stuart Nicol



C. Teodorian

Primary Measurement Standards

Instrument	Serial Number	Cal due date
Power meter Anritsu MA2408A	245025437	Nov. 4, 2011
Power Sensor Anritsu MA2481D	103555	Nov 4, 2011
Attenuator HP 8495A (70dB) 1	944A10711	Sept. 14, 2011
Network Analyzer Agilent E5071C	13347465	Aug. 8, 2012
Secondary Measurement Standards		
Signal Generator Agilent E4438C	-506 MY55182336	June 7, 2012

This page has been reviewed for content and attested to by signature within this document.

NCL Calibration Laboratories

Division of APREL Laboratories.

Calibration Results Summary

The following results relate the Calibrated Dipole and should be used as a quick reference for the user.

Mechanical Dimensions

Length: 72.1 mm
Height: 41.8 mm

Electrical Specification

SWR: 1.0623 U
Return Loss: -30.458 dB
Impedance: 52.141 Ω

System Validation Results

Frequency	1 Gram	10 Gram	Peak
1800 MHz	41.494	21.497	75.767

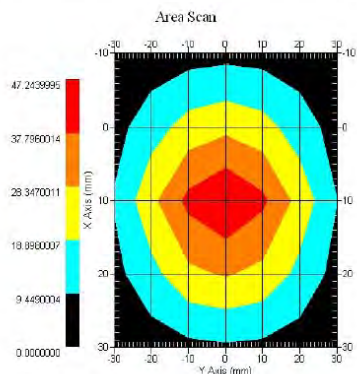

This page has been reviewed for content and attested to by signature within this document.

NCL Calibration Laboratories

Division of APREL Laboratories.

Introduction

This Calibration Report has been produced in line with the SSI Dipole Calibration Procedure SSI-TP-018-ALSAS. The results contained within this report are for Validation Dipole 200-00659. The calibration routine consisted of a three-step process. Step 1 was a mechanical verification of the dipole to ensure that it meets the mechanical specifications. Step 2 was an Electrical Calibration for the Validation Dipole, where the SWR, Impedance, and the Return loss were assessed. Step 3 involved a System Validation using the ALSAS-10U, along with APREL E-020 130 MHz to 26 GHz E-Field Probe Serial Number 212.

References

SSI-TP-018-ALSAS Dipole Calibration Procedure
 SSI-TP-016 Tissue Calibration Procedure
 IEEE 1528 "Recommended Practice for Determining the Peak Spatial-Average Specific Absorption Rate (SAR) in the Human Body Due to Wireless Communications Devices: Experimental Techniques"

Conditions

Dipole 200-00659 was new taken from stock.

Ambient Temperature of the Laboratory: 22 °C +/- 0.5°C
Temperature of the Tissue: 20 °C +/- 0.5°C

Dipole Calibration uncertainty

The calibration uncertainty for the dipole is made up of various parameters presented below.

Mechanical	1%
Positioning Error	1.22%
Electrical	1.7%
Tissue	2.2%
Dipole Validation	2.2%
TOTAL	8.32% (16.64% K=2)

This page has been reviewed for content and attested to by signature within this document.

NCL Calibration Laboratories

Division of APREL Laboratories.

Dipole Calibration Results**Mechanical Verification**

APREL Length	APREL Height	Measured Length	Measured Height
72.0 mm	41.7 mm	72.1 mm	41.8 mm

Electrical Calibration

Test	Result
S11 R/L	-30.458 dB
SWR	1.0623 U
Impedance	52.141 Ω

Tissue Validation

Head Tissue 1800 MHz	Measured
Dielectric constant, ϵ_r	38.38
Conductivity, σ [S/m]	1.39

This page has been reviewed for content and attested to by signature within this document.

5

NCL Calibration Laboratories

Division of APREL Laboratories.

The Following Graphs are the results as displayed on the Vector Network Analyzer.

S11 Parameter Return Loss

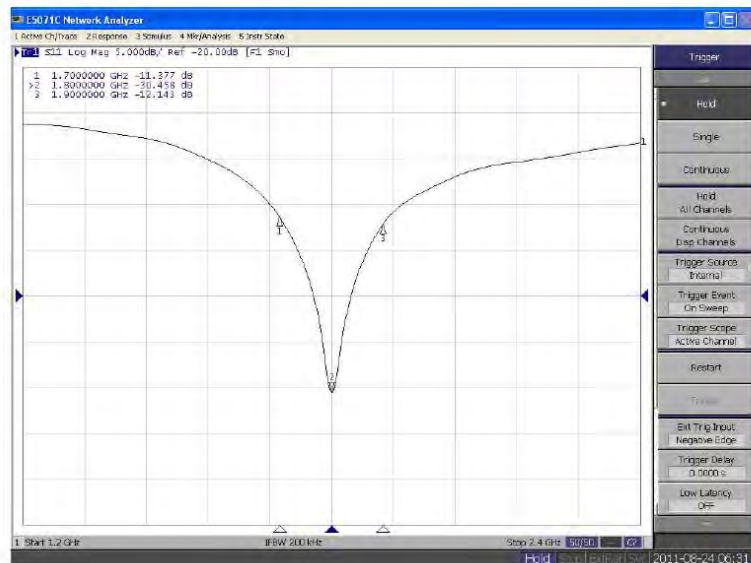

This page has been reviewed for content and attested to by signature within this document.

NCL Calibration Laboratories

Division of APREL Laboratories.

SWR

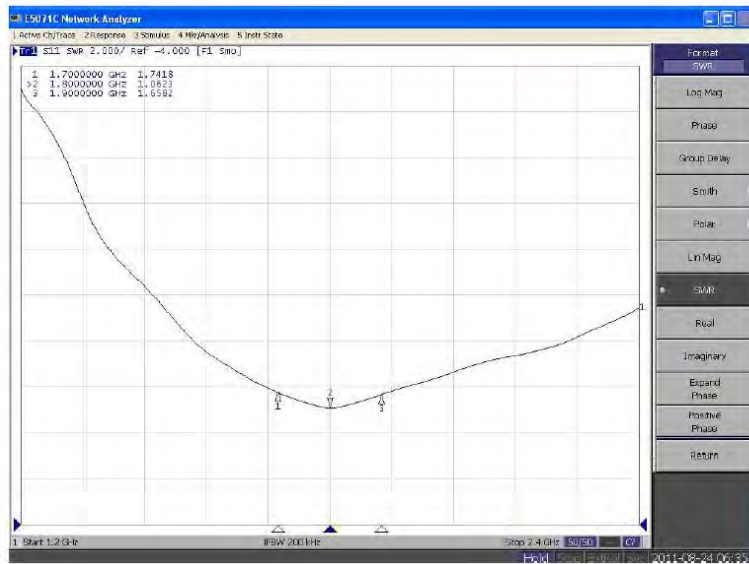

This page has been reviewed for content and attested to by signature within this document.

7

NCL Calibration Laboratories

Division of APREL Laboratories.

Smith Chart Dipole Impedance

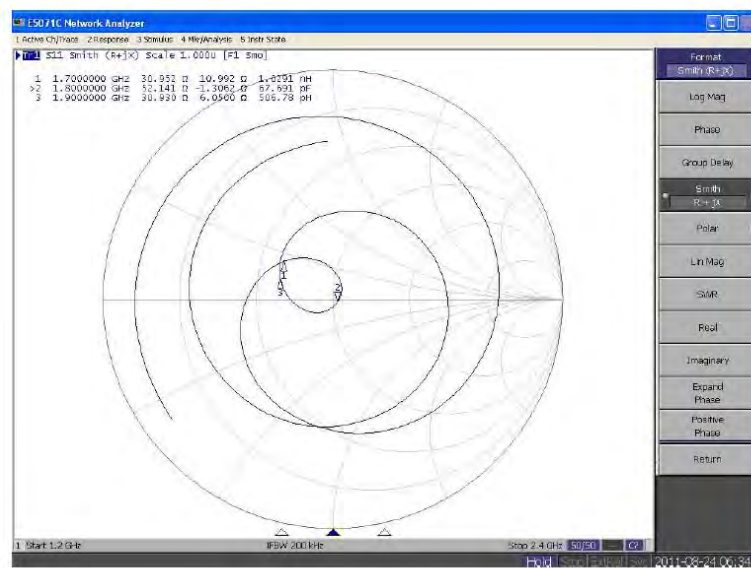

This page has been reviewed for content and attested to by signature within this document.

NCL Calibration Laboratories

Division of APREL Laboratories.

Test Equipment

The test equipment used during Probe Calibration, manufacturer, model number and, current calibration status are listed and located on the main APREL server R:\NCL\Calibration Equipment\Instrument List 2011.

This page has been reviewed for content and attested to by signature within this document.

9

NCL CALIBRATION LABORATORIES

Calibration File No: DC-1331
Project Number: BAC-dipole –cal-5615

CERTIFICATE OF CALIBRATION

It is certified that the equipment identified below has been calibrated in the
NCL CALIBRATION LABORATORIES by qualified personnel following recognized
procedures and using transfer standards traceable to NRC/NIST.

Validation Dipole (Head & Body)

Manufacturer: APREL Laboratories
Part number: ALS-D-1900-S-2
Frequency: 1900 MHz
Serial No: 210-00710

Customer: Bay Area Compliance Laboratory

Calibrated: 25th August, 2011
Released on: 25th August, 2011

This Calibration Certificate is Incomplete Unless Accompanied with the Calibration Results Summary

Released By: _____

NCL CALIBRATION LABORATORIES

Suite 102, 303 Terry Fox Dr.
Kanata, ONTARIO
CANADA K2K 3J1

Division of APREL Lab.
TEL: (613) 435-8300
FAX: (613)435-8306

NCL Calibration Laboratories

Division of APREL Laboratories.

Conditions

Dipole 210-00710 was received in good condition and was a re-calibration.

Ambient Temperature of the Laboratory: 22 °C +/- 0.5°C

Temperature of the Tissue: 21 °C +/- 0.5°C

We the undersigned attest that to the best of our knowledge the calibration of this device has been accurately conducted and that all information contained within this report has been reviewed for accuracy.

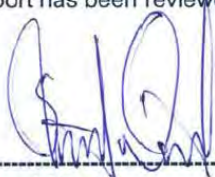

Stuart Nicol



C. Teodorian

Primary Measurement Standards

Instrument	Serial Number	Cal due date
Power meter Anritsu MA2408A	245025437	Nov.4, 2011
Power Sensor Anritsu MA2481D	103555	Nov 4, 2011
Attenuator HP 8495A (70dB) 1	944A10711	Aug.8, 2012
Network Analyzer Agilent E5071C	1334746J	Feb. 8, 2012

Secondary Measurement Standards

Signal Generator Agilent E4438C	-506 MY55182336	June 7, 2012
---------------------------------	-----------------	--------------

This page has been reviewed for content and attested to by signature within this document.

NCL Calibration Laboratories

Division of APREL Laboratories.

Calibration Results Summary

The following results relate the Calibrated Dipole and should be used as a quick reference for the user.

Mechanical Dimensions

Length: 67.1 mm
Height: 38.9 mm

Electrical Specification

Tissue	Frequency	SWR:	Return Loss	Impedance
Head	1900MHz	1.0417 U	-35.395dB	49.020 Ω
Body	1900MHz	1.1177 U	-25.424dB	55.435 Ω

System Validation Results

Tissue	Frequency	1 Gram	10 Gram	Peak
Head	1900 MHz	39.648	20.311	73.365
Body	1900 MHz	39.769	20.176	75.866

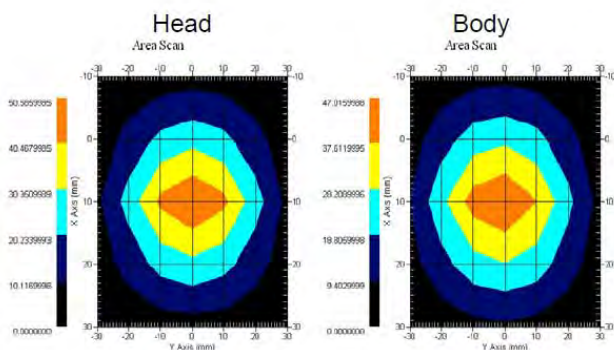

This page has been reviewed for content and attested to by signature within this document.

NCL Calibration Laboratories

Division of APREL Laboratories.

Introduction

This Calibration Report has been produced in line with the SSI Dipole Calibration Procedure SSI-TP-018-ALSAS. The results contained within this report are for Validation Dipole 210-00710. The calibration routine consisted of a three-step process. Step 1 was a mechanical verification of the dipole to ensure that it meets the mechanical specifications. Step 2 was an Electrical Calibration for the Validation Dipole, where the SWR, Impedance, and the Return loss were assessed. Step 3 involved a System Validation using the ALSAS-10U, along with APREL E-020 130 MHz to 26 GHz E-Field Probe Serial Number 212.

References

SSI-TP-018-ALSAS Dipole Calibration Procedure
 SSI-TP-016 Tissue Calibration Procedure
 IEEE 1528 "Recommended Practice for Determining the Peak Spatial-Average Specific Absorption Rate (SAR) in the Human Body Due to Wireless Communications Devices: Experimental Techniques"

Conditions

Dipole 210-00710 was new taken from stock.

Ambient Temperature of the Laboratory: 22 °C +/- 0.5°C
Temperature of the Tissue: 20 °C +/- 0.5°C

Dipole Calibration uncertainty

The calibration uncertainty for the dipole is made up of various parameters presented below.

Mechanical	1%
Positioning Error	1.22%
Electrical	1.7%
Tissue	2.2%
Dipole Validation	2.2%
TOTAL	8.32% (16.64% K=2)

This page has been reviewed for content and attested to by signature within this document.

NCL Calibration Laboratories

Division of APREL Laboratories.

Dipole Calibration Results

Mechanical Verification

APREL Length	APREL Height	Measured Length	Measured Height
68.0 mm	39.5 mm	67.1mm	38.9 mm

Electrical Validation

Tissue Type	Return Loss:	SWR:	Impedance:
Head	-29.360 dB	1.0732 U	47.869 Ω
Body	-22.799 dB	1.1566 U	48.022 Ω

Tissue Validation

	Dielectric constant, ϵ_r	Conductivity, σ [S/m]
Head Tissue 1900MHz	38.4	1.43
Body Tissue 1900MHz	51.87	1.59

This page has been reviewed for content and attested to by signature within this document.

NCL Calibration Laboratories

Division of APREL Laboratories.

The Following Graphs are the results as displayed on the Vector Network Analyzer.

S11 Parameter Return Loss

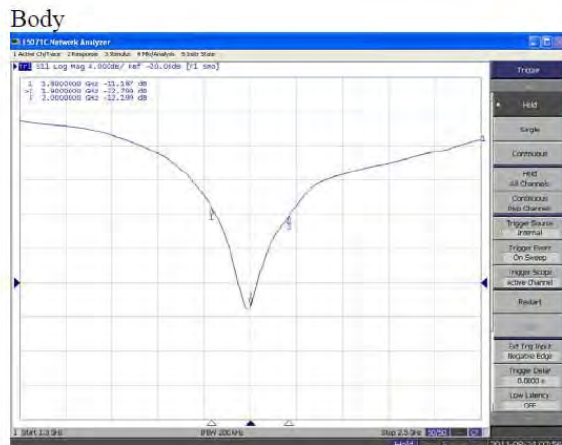
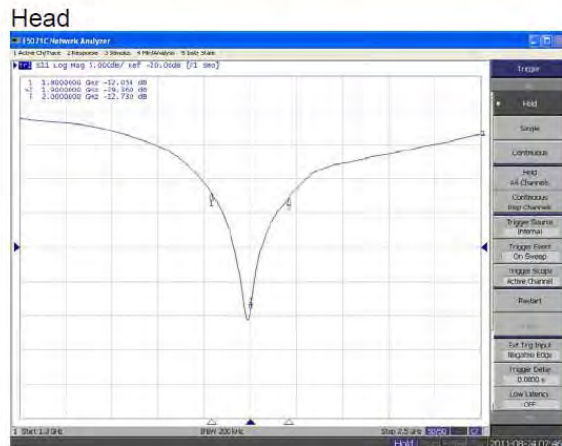

This page has been reviewed for content and attested to by signature within this document.

NCL Calibration Laboratories

Division of APREL Laboratories.

SWR

Head

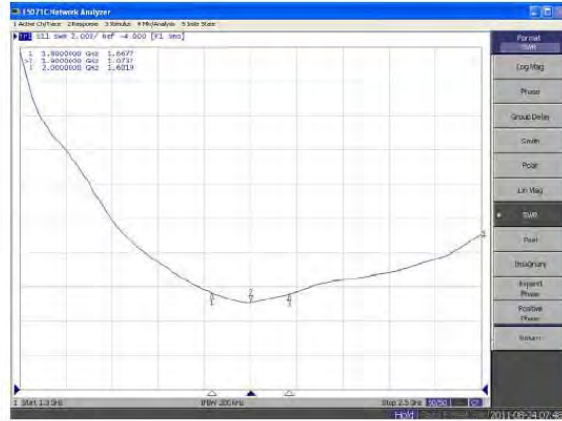

Body

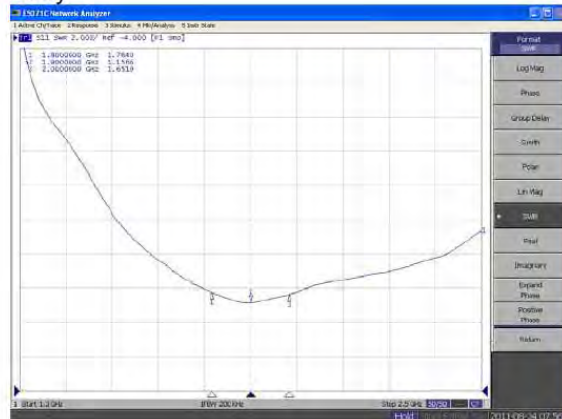

This page has been reviewed for content and attested to by signature within this document.

NCL Calibration Laboratories

Division of APREL Laboratories.

Smith Chart Dipole Impedance

Head

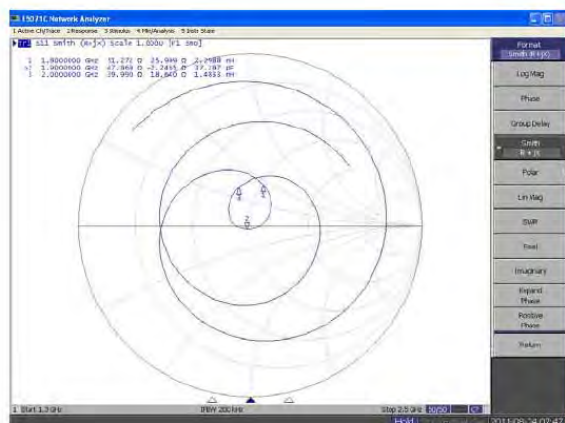

Body

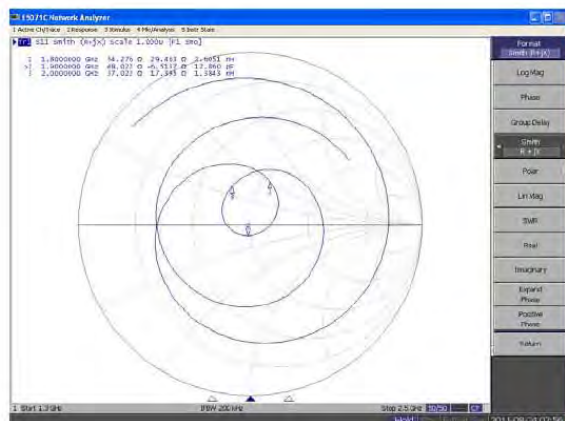

This page has been reviewed for content and attested to by signature within this document.

NCL Calibration Laboratories

Division of APREL Laboratories.

Test Equipment

The test equipment used during Probe Calibration, manufacturer, model number and, current calibration status are listed and located on the main APREL server R:\NCL\Calibration Equipment\Instrument List 2011

This page has been reviewed for content and attested to by signature within this document.

9

1900MHz Dipole Calibration By BACL at 2012-12-12

Mechanical Verification

APREL Length	APREL Height	Measured Length	Measured Height
68.0 mm	39.5 mm	68.2 mm	39.2 mm

Tissue Type	Measured Return Loss	Measured Impedance
Head	-28.284 dB	49.471 Ω
Body	-22.445 dB	51.588 Ω

Test Graphs:

Head Tissue

Return Loss :

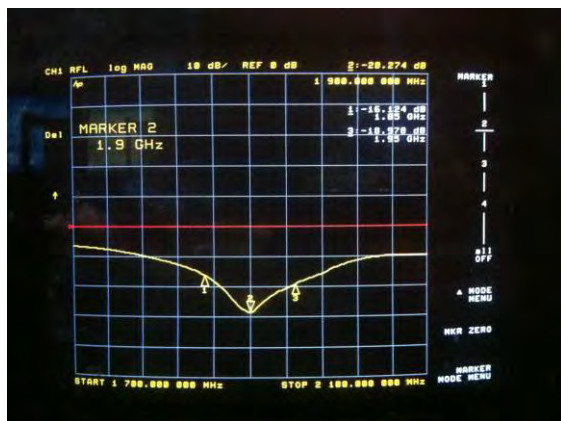

Impedance :



Body Tissue

Return Loss :

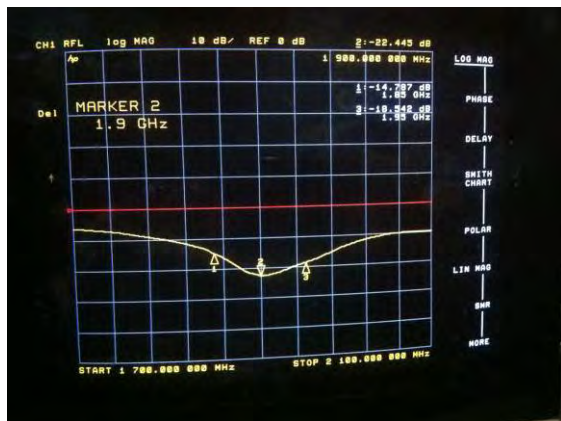

Impedance :



NCL CALIBRATION LABORATORIES

Calibration File No: DC-1330
Project Number: BAC-dipole-cal-5619

CERTIFICATE OF CALIBRATION

It is certified that the equipment identified below has been calibrated in the **NCL CALIBRATION LABORATORIES** by qualified personnel following recognized procedures and using transfer standards traceable to NRC/NIST.

Validation Dipole (Head & Body)

Manufacturer: APREL Laboratories
Part number: ALS-D-2450-S-2
Frequency: 2450 MHz
Serial No: 220-00758

Customer: Bay Area Compliance Laboratory

Calibrated: 25th August, 2011
Released on: 25th August, 2011

This Calibration Certificate is Incomplete Unless Accompanied with the Calibration Results Summary

Released By: _____

***NCL* CALIBRATION LABORATORIES**

Suite 102, 303 Terry Fox Dr.
Kanata, ONTARIO
CANADA K2K 3J1

Division of APREL Lab.
TEL: (613) 435-8300
FAX: (613)435-8306

NCL Calibration Laboratories

Division of APREL Laboratories.

Conditions

Dipole 220-00758 was received in good condition and was a re-calibration.

Ambient Temperature of the Laboratory: 22 °C +/- 0.5°C

Temperature of the Tissue: 21 °C +/- 0.5°C

We the undersigned attest that to the best of our knowledge the calibration of this device has been accurately conducted and that all information contained within this report has been reviewed for accuracy.



Stuart Nicol



C. Teodorian

Primary Measurement Standards

Instrument	Serial Number	Cal due date
Power meter Anritsu MA2408A	245025437	Nov.4, 2011
Power Sensor Anritsu MA2481D	103555	Nov 4, 2011
Attenuator HP 8495A (70dB) 1	944A10711	Aug.8, 2012
Network Analyzer Agilent E5071C	1334746J	Feb. 8, 2012
Secondary Measurement Standards		
Signal Generator Agilent E4438C	-506 MY55182336	June 7, 2012

This page has been reviewed for content and attested to by signature within this document.

NCL Calibration Laboratories

Division of APREL Laboratories.

Calibration Results Summary

The following results relate the Calibrated Dipole and should be used as a quick reference for the user.

Mechanical Dimensions

Length: 52.4 mm
Height: 30.3 mm

Electrical Specification

Tissue	Frequency	SWR:	Return Loss	Impedance
Head	2450 MHz	1.0459 U	-33.024 dB	48.533 Ω
Body	2450 MHz	1.1159 U	-25.235 dB	46.676 Ω

System Validation Results

Tissue	Frequency	1 Gram	10 Gram	Peak
Head	2450 MHz	52.667	24.518	105.920
Body	2450 MHz	52.561	24.104	108.940

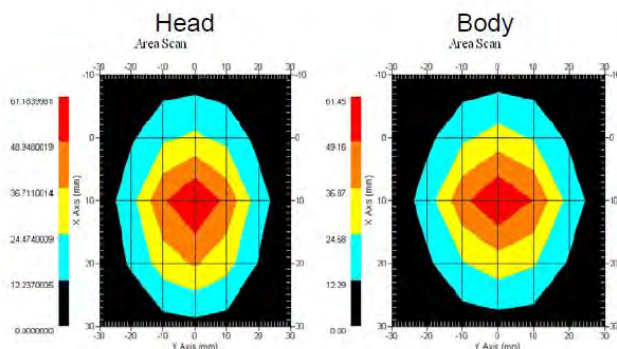

This page has been reviewed for content and attested to by signature within this document.

NCL Calibration Laboratories

Division of APREL Laboratories.

Introduction

This Calibration Report has been produced in line with the SSI Dipole Calibration Procedure SSI-TP-018-ALSAS. The results contained within this report are for Validation Dipole 220-00758. The calibration routine consisted of a three-step process. Step 1 was a mechanical verification of the dipole to ensure that it meets the mechanical specifications. Step 2 was an Electrical Calibration for the Validation Dipole, where the SWR, Impedance, and the Return loss were assessed. Step 3 involved a System Validation using the ALSAS-10U, along with APREL E-020 130 MHz to 26 GHz E-Field Probe Serial Number 212.

References

- SSI-TP-018-ALSAS Dipole Calibration Procedure
- SSI-TP-016 Tissue Calibration Procedure
- IEEE 1528 "Recommended Practice for Determining the Peak Spatial-Average Specific Absorption Rate (SAR) in the Human Body Due to Wireless Communications Devices: Experimental Techniques"
- IEC-62209 "Human exposure to radio frequency fields from hand-held and body-mounted wireless communication devices – Human models, instrumentation, and procedures"
- Part 1: "Procedure to determine the Specific Absorption Rate (SAR) for hand-held devices used in close proximity of the ear (frequency range of 300 MHz to 3 GHz)"
- IEC-62209 "Human exposure to radio frequency fields from hand-held and body-mounted wireless communication devices – Human models, instrumentation, and procedures"
- Part 2 *Draft*: "Procedure to determine the Specific Absorption Rate (SAR) for hand-held devices used in close proximity of the ear (frequency range of 30 MHz to 6 GHz)"

Conditions

Dipole 220-00758 was a re-calibration.

Ambient Temperature of the Laboratory: 22 °C +/- 0.5°C
Temperature of the Tissue: 20 °C +/- 0.5°C

Dipole Calibration uncertainty

The calibration uncertainty for the dipole is made up of various parameters presented below.

Mechanical	1%
Positioning Error	1.22%
Electrical	1.7%
Tissue	2.2%
Dipole Validation	2.2%
TOTAL	8.32% (16.64% K=2)

This page has been reviewed for content and attested to by signature within this document.

NCL Calibration Laboratories

Division of APREL Laboratories.

Dipole Calibration Results**Mechanical Verification**

APREL Length	APREL Height	Measured Length	Measured Height
51.5 mm	30.4 mm	52.4 mm	30.3 mm

Electrical Calibration

Tissue Type	Return Loss:	SWR:	Impedance:
Head	-33.024 dB	1.0459 U	48.533 Ω
Body	-25.235 dB	1.1159 U	46.676 Ω

Tissue Validation

	Dielectric constant, ϵ_r	Conductivity, σ [S/m]
Head Tissue 2450MHz	38.2	1.82
Body Tissue 2450MHz	51.74	1.96

This page has been reviewed for content and attested to by signature within this document.

5

NCL Calibration Laboratories

Division of APREL Laboratories.

The Following Graphs are the results as displayed on the Vector Network Analyzer.

S11 Parameter Return Loss

Head

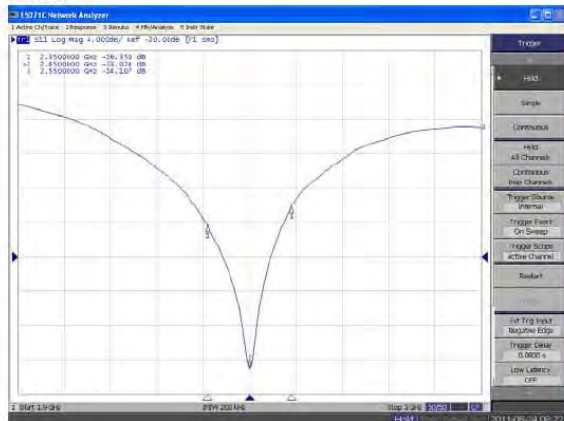

Body

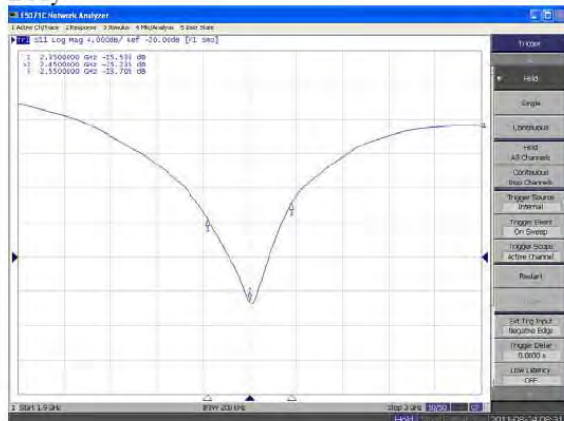

This page has been reviewed for content and attested to by signature within this document.

NCL Calibration Laboratories

Division of APREL Laboratories.

SWR

Head

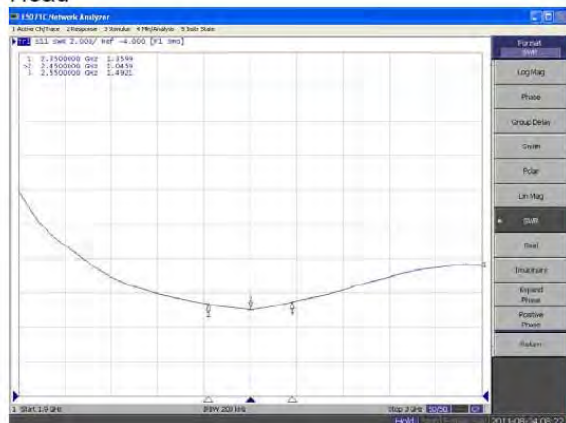

Body

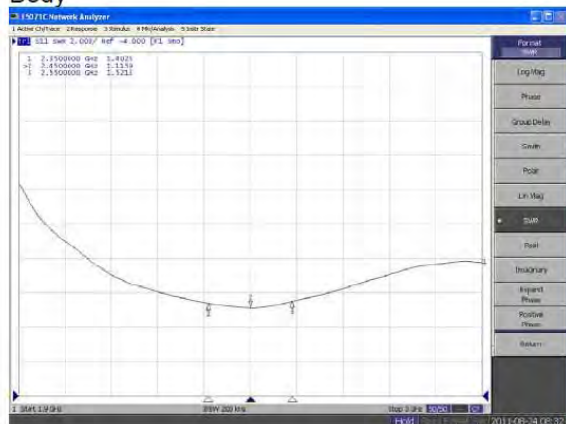

This page has been reviewed for content and attested to by signature within this document.

NCL Calibration Laboratories

Division of APREL Laboratories.

Smith Chart Dipole Impedance

Head

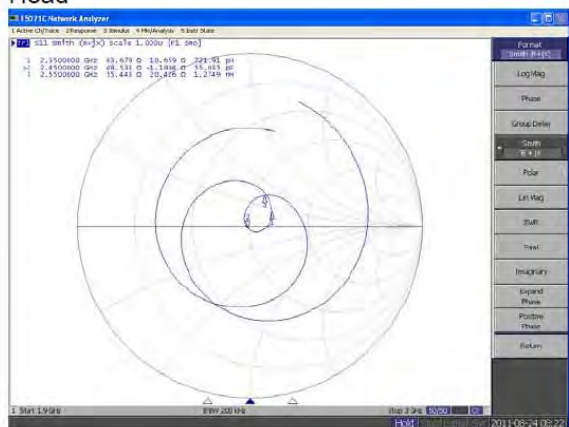

Body

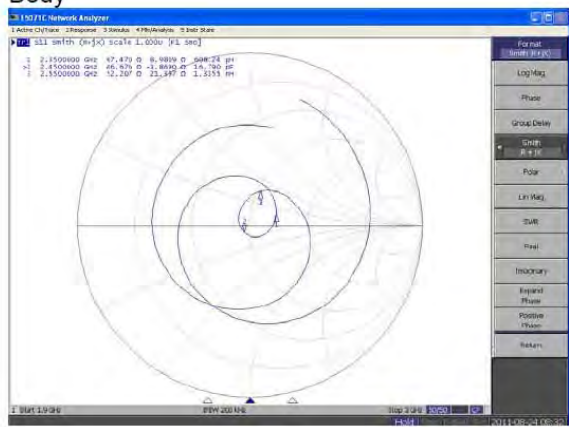

This page has been reviewed for content and attested to by signature within this document.

NCL Calibration Laboratories

Division of APREL Laboratories.

Test Equipment

The test equipment used during Probe Calibration, manufacturer, model number and, current calibration status are listed and located on the main APREL server R:\NCL\Calibration Equipment\Instrument List May 2011.

This page has been reviewed for content and attested to by signature within this document.

9

2450MHz Dipole Calibration By BACL at 2012-12-12

Mechanical Verification

APREL Length	APREL Height	Measured Length	Measured Height
51.5mm	30.4 mm	51.6 mm	30.2 mm

Tissue Type	Measured Return Loss	Measured Impedance
Head	-35.559 dB	49.627 Ω
Body	-27.477 dB	48.238 Ω

Test Graphs:

Head Tissue

Return Loss :

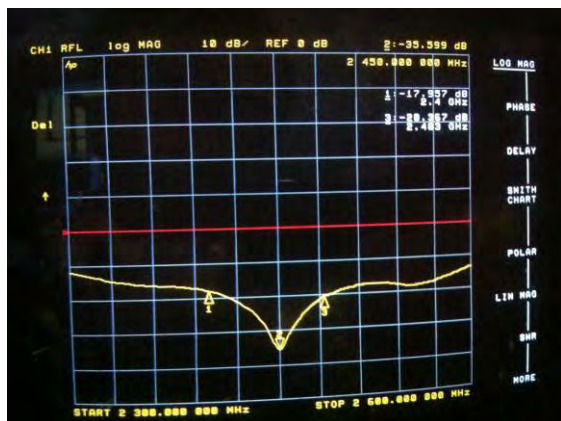

Impedance :

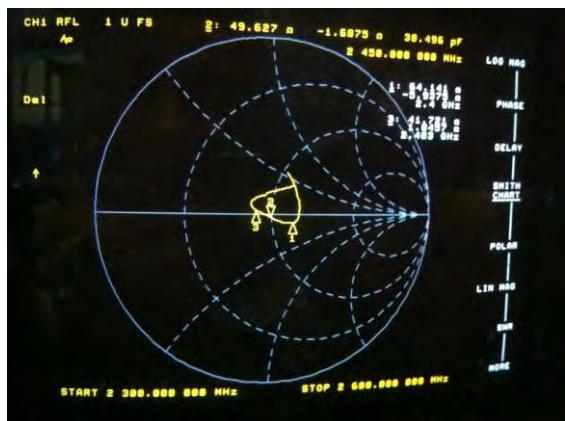

Body Tissue

Return Loss :

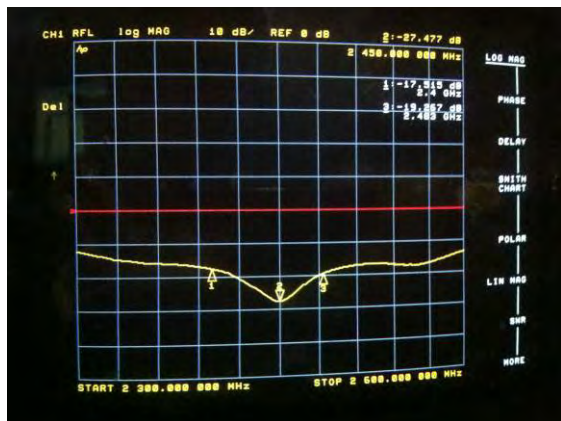

Impedance :



APPENDIX D EUT TEST POSITION PHOTOS

Liquid depth $\geq 15\text{cm}$

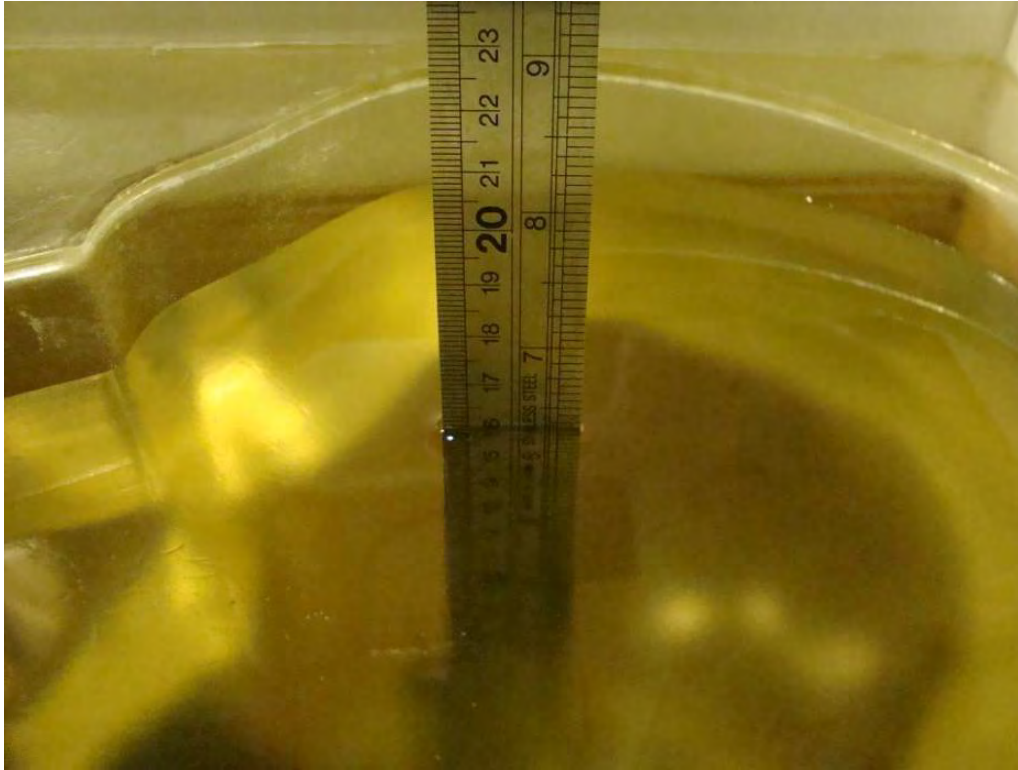

Body-worn-Headset Front Setup Photo

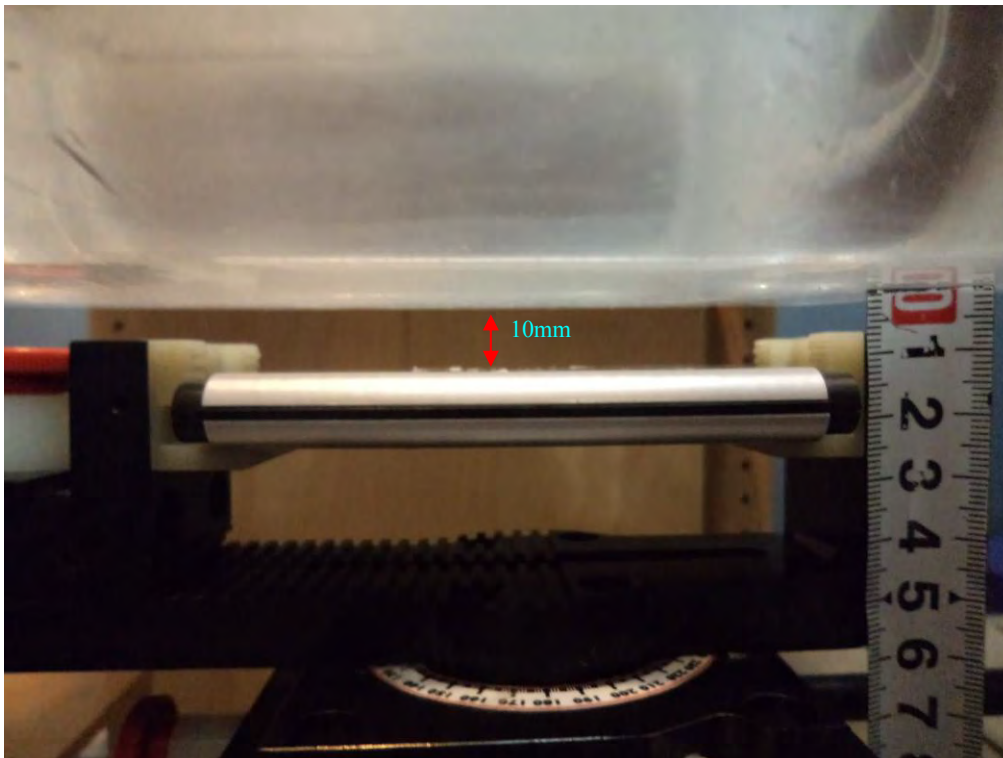

Body-worn-Headset Back Setup Photo

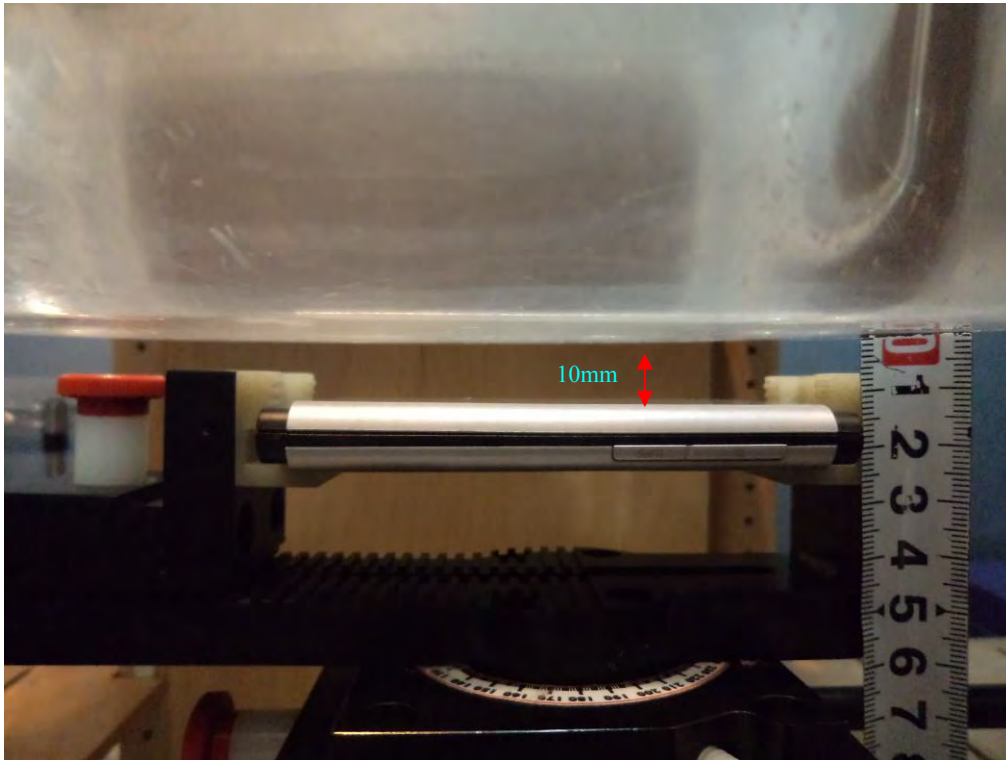

Body-Left Setup Photo



Body-Right Setup Photo



Body-Bottom Setup Photo

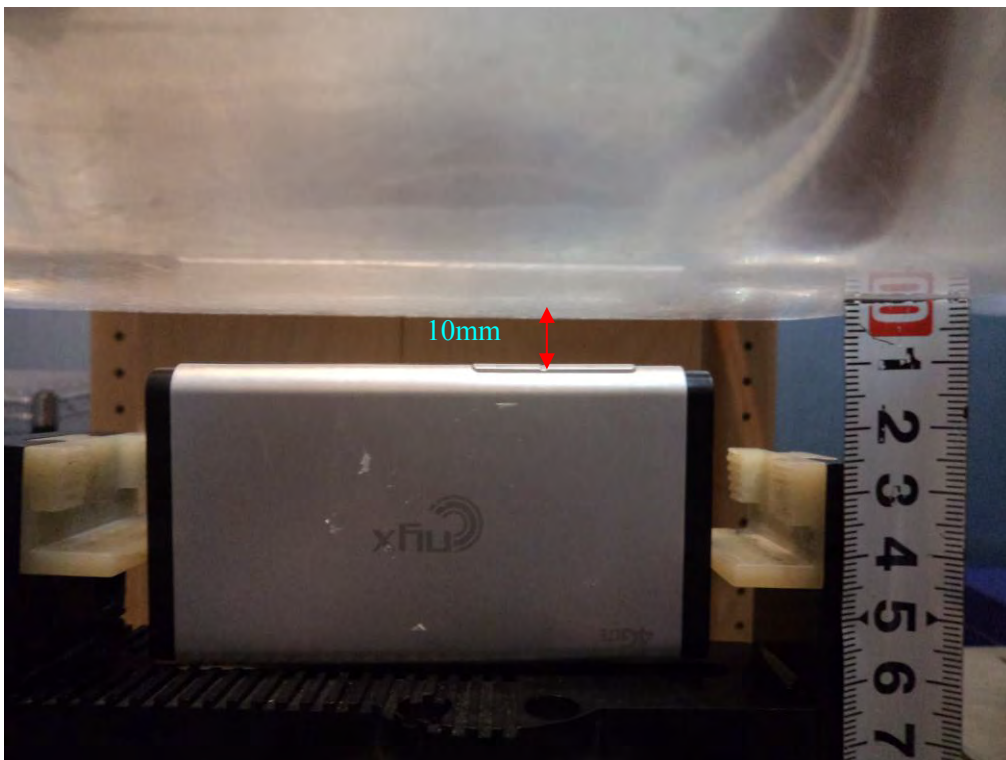

Body-Top Setup Photo

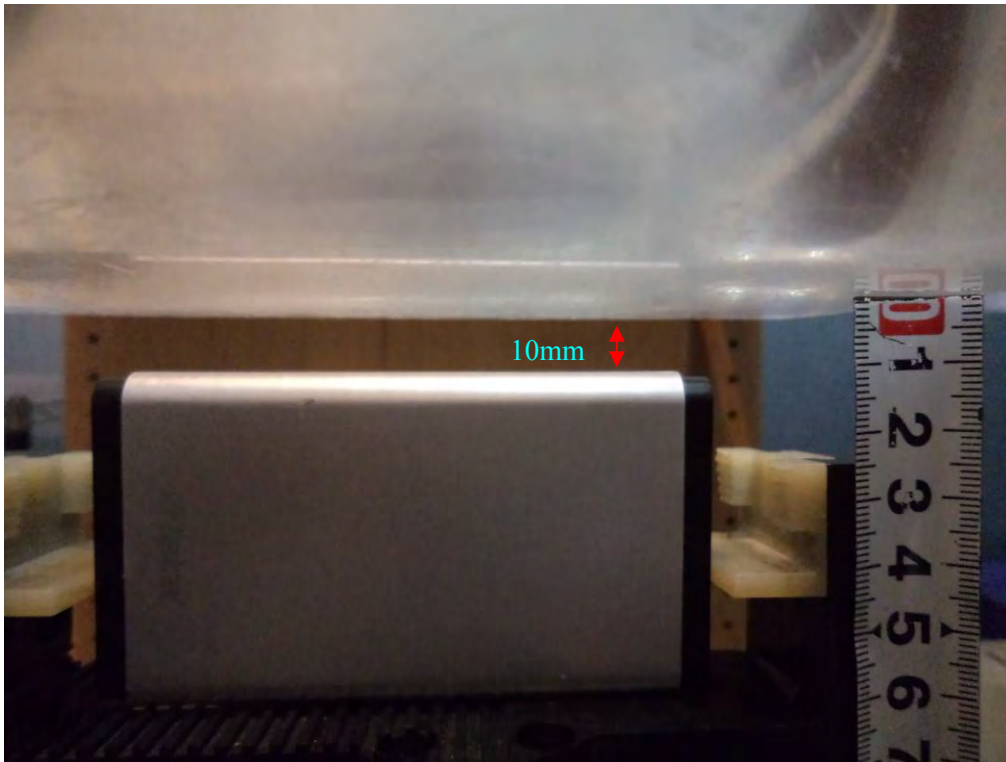

APPENDIX E EUT PHOTOS

EUT – Front View



EUT – Back View



EUT – Right View



EUT – Left View

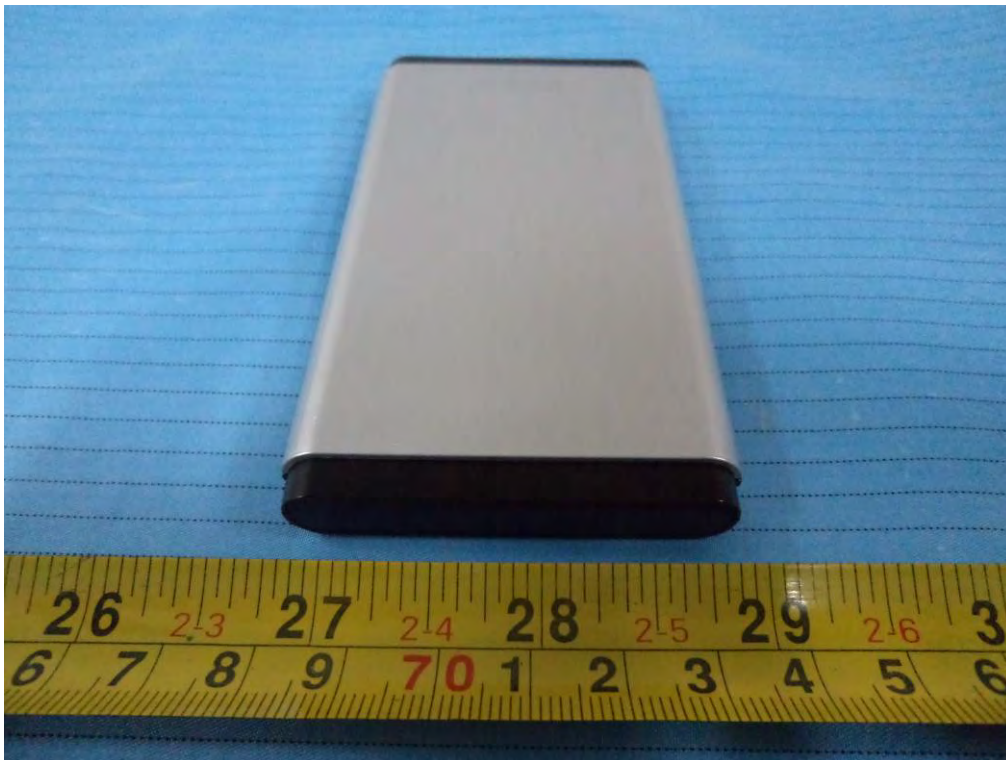

EUT – Uncovered View



APPENDIX F INFORMATIVE REFERENCES

- [1] Federal Communications Commission, \Report and order: Guidelines for evaluating the environmental effects of radiofrequency radiation", Tech. Rep. FCC 96-326, FCC, Washington, D.C. 20554, 1996.
- [2] David L. Means Kwok Chan, Robert F. Cleveland, \Evaluating compliance with FCC guidelines for human exposure to radiofrequency electromagnetic fields", Tech. Rep., Federal Communication Commission, Office of Engineering & Technology, Washington, DC, 1997.
- [3] Thomas Schmid, Oliver Egger, and Niels Kuster, \Automated E-field scanning system for dosimetric assessments", IEEE Transactions on Microwave Theory and Techniques, vol. 44, pp. 105-113, Jan. 1996.
- [4] Niels Kuster, Ralph Kastle, and Thomas Schmid, \Dosimetric evaluation of mobile communications equipment with known precision", IEEE Transactions on Communications, vol. E80-B, no. 5, pp. 645-652, May 1997.
- [5] CENELEC, \Considerations for evaluating of human exposure to electromagnetic fields (EMFs) from mobile telecommunication equipment (MTE) in the frequency range 30MHz - 6GHz", Tech. Rep., CENELEC, European Committee for Electrotechnical Standardization, Brussels, 1997.
- [6] ANSI, ANSI/IEEE C95.1-1992: IEEE Standard for Safety Levels with Respect to Human Exposure to Radio Frequency Electromagnetic Fields, 3 kHz to 300 GHz, The Institute of Electrical and Electronics Engineers, Inc., New York, NY 10017, 1992.
- [7] Katja Pokovic, Thomas Schmid, and Niels Kuster, \Robust setup for precise calibration of E-field probes in tissue simulating liquids at mobile communications frequencies", in ICECOM '97, Dubrovnik, October 15-17, 1997, pp. 120-24.
- [8] Katja Pokovic, Thomas Schmid, and Niels Kuster, \E-field probe with improved isotropy in brain simulating liquids", in Proceedings of the ELMAR, Zadar, Croatia, 23-25 June, 1996, pp. 172-175.
- [9] Volker Hombach, Klaus Meier, Michael Burkhardt, Eberhard Kuhn, and Niels Kuster, \The dependence of EM energy absorption upon human head modeling at 900 MHz", IEEE Transactions on Microwave Theory and Techniques, vol. 44, no. 10, pp. 1865-1873, Oct. 1996.
- [10] Klaus Meier, Ralf Kastle, Volker Hombach, Roger Tay, and Niels Kuster, \The dependence of EM energy absorption upon human head modeling at 1800 MHz", IEEE Transactions on Microwave Theory and Techniques, Oct. 1997, in press.
- [11] W. Gander, Computermathematik, Birkhaeuser, Basel, 1992.
- [12] W. H. Press, S. A. Teukolsky, W. T. Vetterling, and B. P. Flannery, Numerical Recipes in C, The Art of Scientific Computing, Second Edition, Cambridge University Press, 1992. Dosimetric Evaluation of Sample device, month 1998 9
- [13] NIS81 NAMAS, \The treatment of uncertainty in EMC measurement", Tech. Rep., NAMAS Executive, National Physical Laboratory, Teddington, Middlesex, England, 1994.
- [14] Barry N. Taylor and Christ E. Kuyatt, \Guidelines for evaluating and expressing the uncertainty of NIST measurement results", Tech. Rep., National Institute of Standards and Technology, 1994. Dosimetric Evaluation of Sample device, month 1998 10.
- [15] FCC OET KDB648474 Do1 SAR Evaluation Considerations for Handsets with Multiple transmitters and Antennas.

***** END OF REPORT *****