

2.4GHZ TRANSMITTER CONTROLLER

- 2 CHANNELS

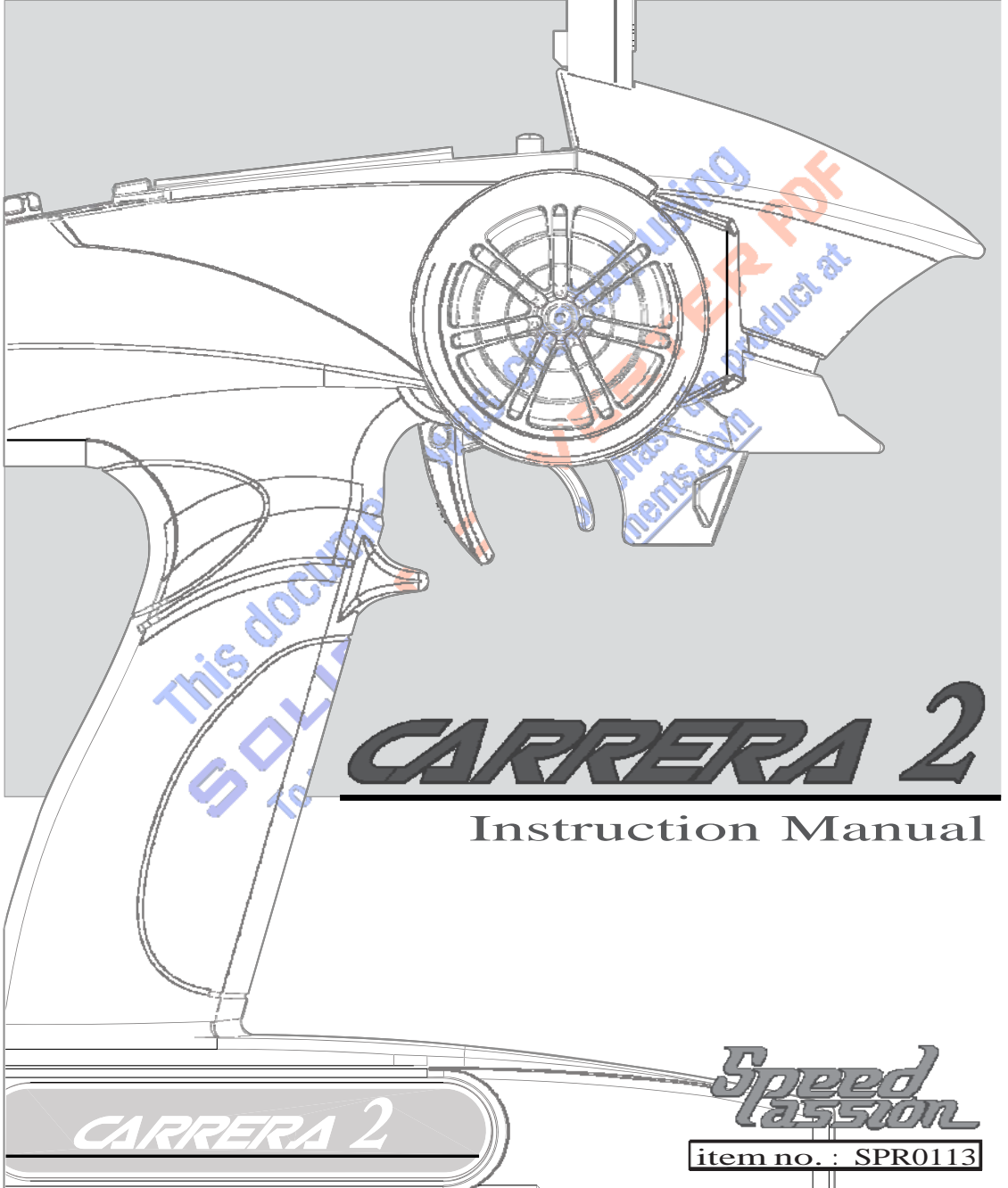

CARRERA 2

Instruction Manual

CARRERA 2

***Speed
Passion***

item no. : SPR0113

INTRODUCTION

Thank you for choosing our 2.4G digital radio control products, Please read through this manual to familiarize yourself with the operation of the transmitter before use. Keep this manual for future troubleshooting if you have any problems during operation. Once again, thanks for buying our products,



This product is warranted against manufacturing defects for a period of one year after purchase. This warranty does not cover abuse or physical damage caused by the user. Please visit www.speedpassion.net for warranty service contact information in your region and return instructions.

If you find any problems during operation, please refer to this manual for a solution. If the problem still exists, please visit www.speedpassion.net



EXPLANATION OF SYMBOLS

Please pay attention to the following symbols when they appear in the manual, and please read carefully.

	Danger:	Failure to follow these instructions, may lead to serious injuries or mortal danger.
	Warning:	Failure to follow these instructions, may lead to serious injuries or mortal danger.
	Attention:	Failure to follow these instructions, may lead to minor injuries.



Prohibition



Mandatory



Do not operate in bad weather such as rain or thunderstorms to assure the safety of you and others.



Before you operate, please make sure the direction of the radio movements match with the direction of car movements. If not, please adjust before driving.



Always turn on the transmitter first, then turn on the receiver. Always turn off the receiver power first, then turn off the transmitter power.



If the above operations are reversed, it might lead to an uncontrolled vehicle and accident.

TRANSMITTER AND RECEIVER PARAMETERS

TRANSMITTER PARAMETERS

Specifications:

- Model type: Car/Boat
- RF power: less than 20dbm
- Modulation: GFSK
- Code type: Digital
- Sensitivity: 1024
- Low voltage warning: Yes(less than 9V)
- DSC port: Yes(3.5mm)
- Power: 12vdc(1.5AAx8)
- Weight: 357g
- ANT length: 26mm
- Size: 227 X 268 X 97mm
- Certificate: CE FCC

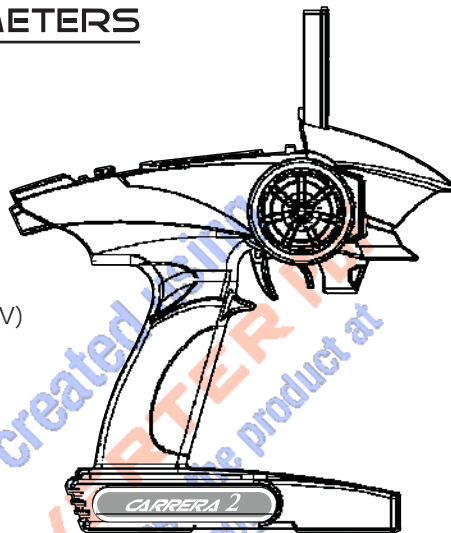

RECEIVER PARAMETERS

Specifications:

- Channels: 3 Channels
- Model type: Car/Boat
- Frequency bank: 2.4G
- Modulation: GFSK
- Sensitivity: 1024
- RF. receiver sensitivity: -100dbm
- Power: 4.5-6vdc
- Weight: 6g
- ANT length: 26mm
- Size: 36.5 X 23.3 X 13.3mm
- Certificate: CE FCC

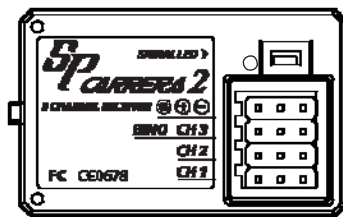

ITEM NO. : SPRO3

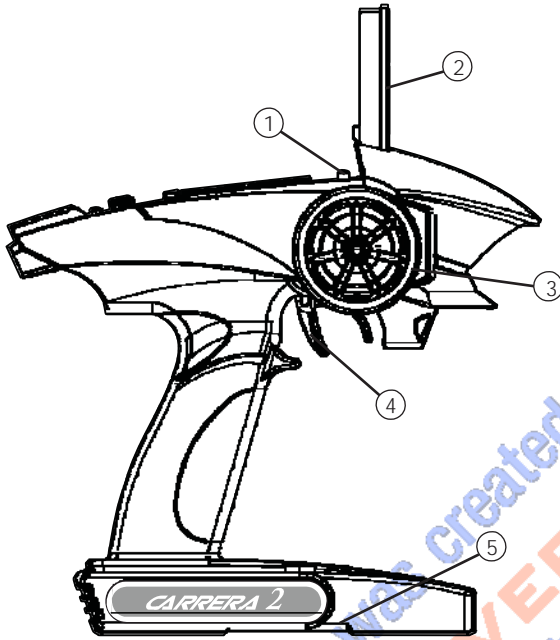

- ① On/Off Switch
- ② 2.4G Antenna
- ③ Steering Wheel
- ④ Throttle Trigger
- ⑤ Battery Box

This document was created using
SOLID CONVERTER PRO
To remove this message, purchase the product at
www.SolidDocuments.com



RECEIVER CONNECTIVITY

INSTALLATION WHEN A MOTOR CONTROLLER IS USED

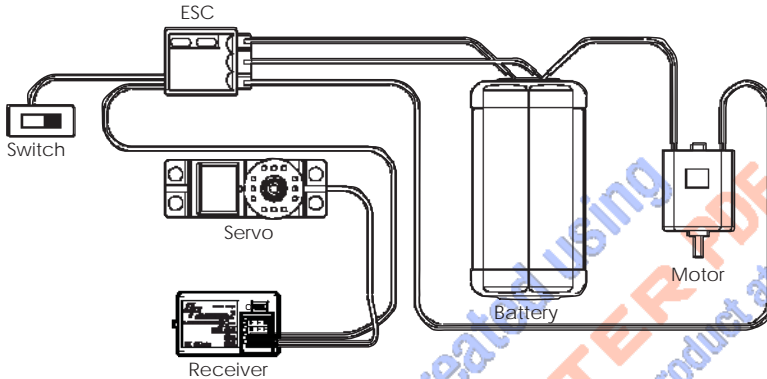

INSTALLATION FOR GAS POWERED MODELS

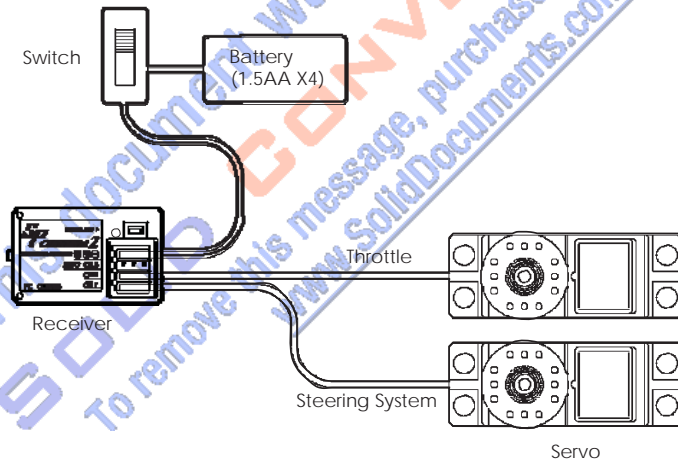

Note: Route the antenna of the receiver straight up, and avoid metal or wires to assure its sensitivity.

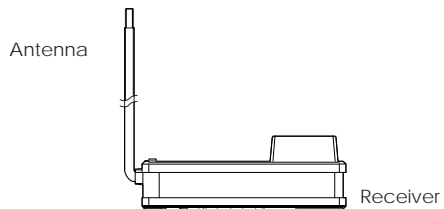

This document was created using
Solid Converter PDF
To remove this message, purchase the product at
www.SolidDocuments.com

BINDING (CODE)

Our products are bound from the factory, so you do not need to bind them yourself. To bind the receiver with another transmitter, please follow the following steps:

- A. Install the battery to 2.4G transmitter
- B. Insert the bind plug to the channel BIND /CH3 port of the receiver.
- C. Connect the receiver battery to VCC port of the receiver. The two LED will be flashing and this means the receiver is ready to bind.
- D. Press and hold the bind button on the transmitter, and then switch on the power.
- E. Observe the LED on the receiver, if the LED is not flashing, the bind was successful. (May take about 5s)
- F. Release the bind button on the transmitter, and remove the bind plug from the receiver.
- G. Install a servo and test.
- H. If the test fails, please repeat the process above.
- I. If the tests succeeds, the bind is complete. (The above ways of match is only suitable on this products)

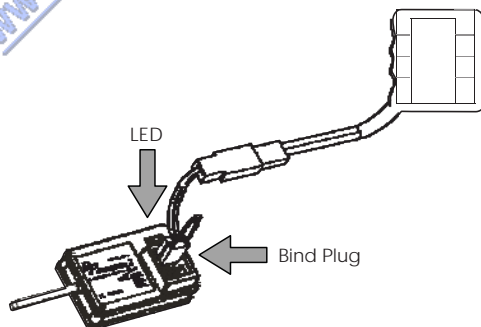
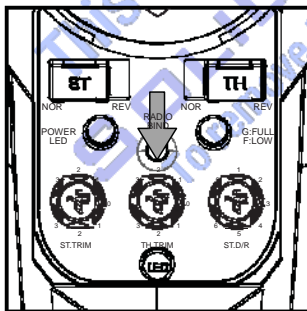

POWER ON:

- A. Complete installation.
- B. Turn on transmitter.
 - 1. Press the antenna until it press the On/Off switch.
 - 2. Flip the antenna to vertical position.
- C. Turn on receiver.
- D. Receiver LED light should be solid.
- E. Ready to use.

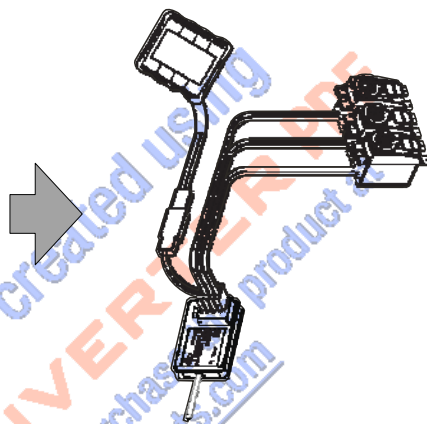
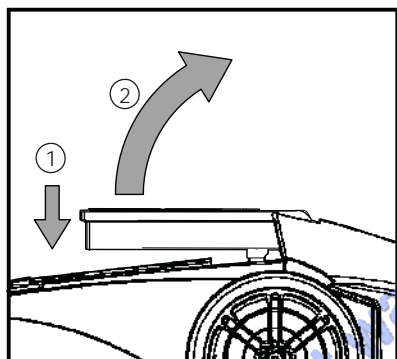

SHUT DOWN:

- A. Turn off the receiver.
- B. Turn off transmitter.
 - 1. Flip the antenna down until it press the On/Off switch.

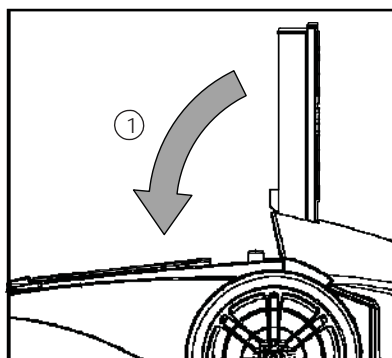
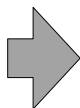
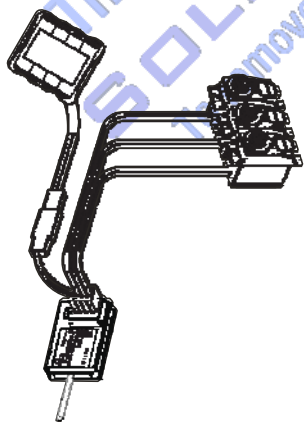

TRANSMITTER FUNCTION NOTES

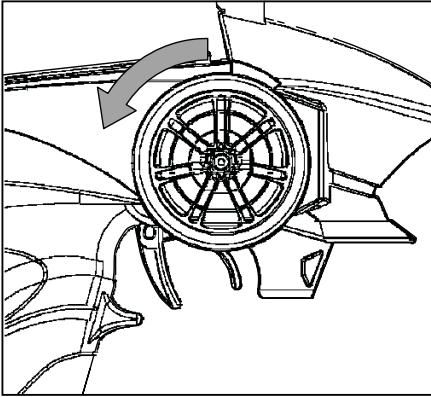

fig.1

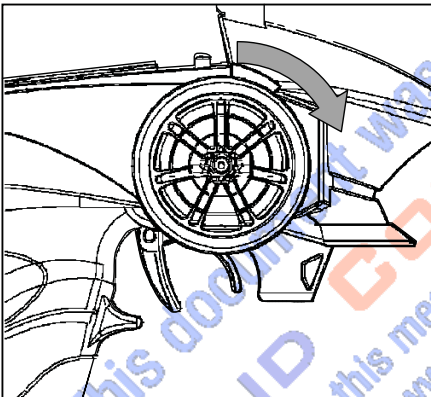
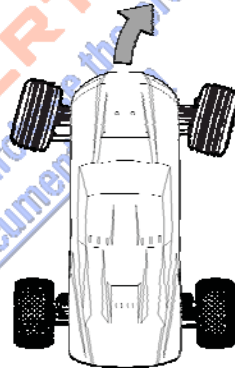
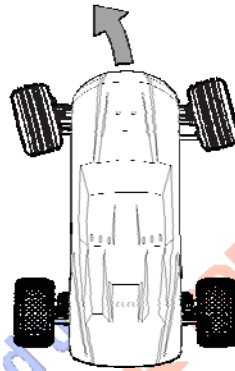

fig.2



FUNCTION INTRODUCTION:

This function controls steering, when the steering wheel turns to right, then the front wheels will turn to the right (please see fig.1.). when the steering wheel turns to the left, then the front wheels will turn to the left (please see fig.2.).

OPERATION METHOD:

Adjust the dual rate of the steering by adjusting the D/R knob.

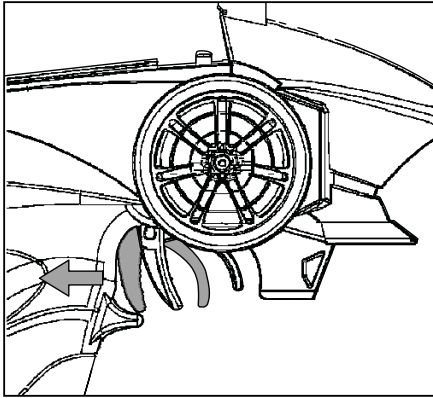

fig.3

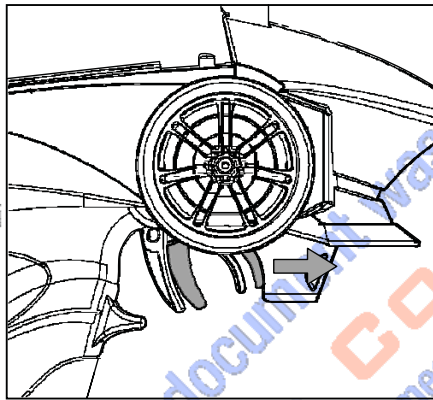
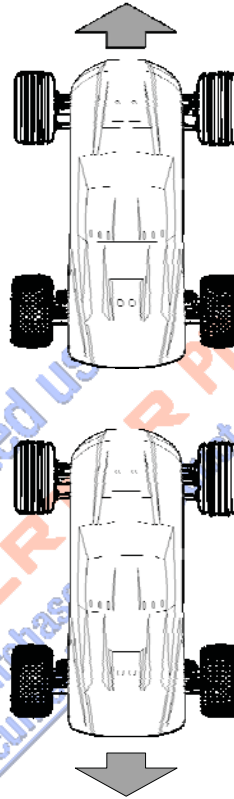

fig.4



FUNCTION INTRODUCTION:

This function controls the throttle speed, When you pull the throttle trigger, the car will accelerate forward (please see fig.3). when you push the throttle trigger forward, the car will put on the brakes. According to your ESC settings, you may access reverse by pushing the trigger all the way forward quickly twice (double tap) (please see fig.4).

OPERATION METHOD:

Control throttle by pushing and pulling back the throttle trigger after the power is on.



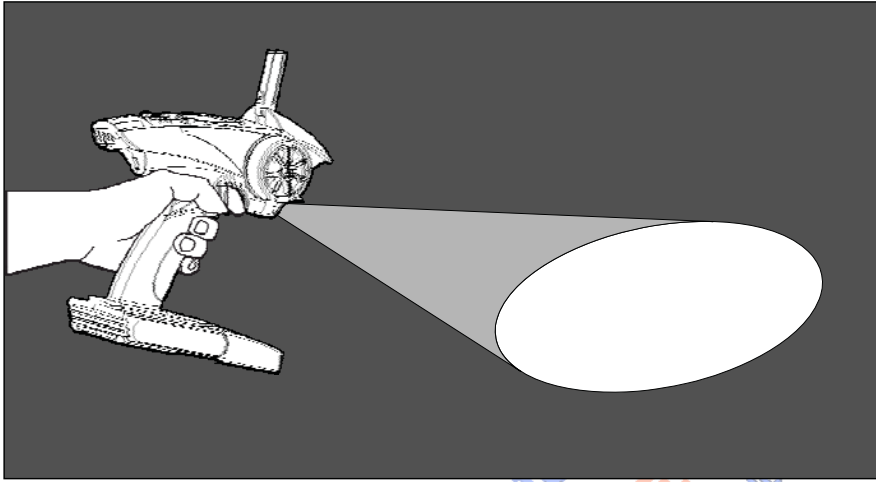

FUNCTION INTRODUCTION:

When you switch on the transmitter, you can press the LED button on the panel to switch on the lighting function.

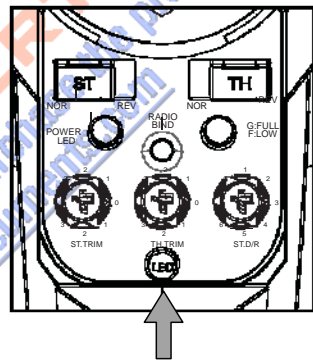

LED Button

This document was created by SOLID CONVERTER To remove this message, purchase the product from www.SolidDoc.com



MEMO

The users manual or instruction manual for an intentional or unintentional radiator shall caution the user that changes or modifications not expressly approved by the party responsible for compliance could void the user's authority to operate the equipment. In cases where the manual is provided only in a form other than paper, such as on a computer disk or over the Internet, the information required by this section may be included in the manual in that alternative form, provided the user can reasonably be expected to have the capability to access information in that form.

NOTE:

THE MANUFACTURER IS NOT RESPONSIBLE FOR ANY RADIO OR TV INTERFERENCE CAUSED BY UNAUTHORIZED MODIFICATIONS TO THIS EQUIPMENT. SUCH MODIFICATIONS COULD VOID THE USER AUTHORITY TO OPERATE THE EQUIPMENT

NOTE: This equipment has been tested and found to comply with the limits for a Class B digital device, pursuant to Part 15 of the FCC Rules. These limits are designed to provide reasonable protection against harmful interference in a residential installation. This equipment generates, uses and can radiate radio frequency energy and, if not installed and used in accordance with the instructions, may cause harmful interference to radio communications. However, there is no guarantee that interference will not occur in a particular installation. If this equipment does cause harmful interference to radio or television reception, which can be determined by turning the equipment off and on, the user is encouraged to try to correct the interference by one or more of the following measures:

- Reorient or relocate the receiving antenna.
- Increase the separation between the equipment and receiver.
- Connect the equipment into an outlet on a circuit different from that to which the receiver is connected.
- Consult the dealer or an experienced radio/TV technician for help.





***Speed
Passion***

www.speedpassion.net

Email: sale@king-golden.com

Tel: (852) 3586-2398 Fax: (852) 3586-2148

USA Support email: usasupport@king-golden.com

USA Toll Free line: 866-369-0636