

FCC RF Test Report

APPLICANT : CT Asia
EQUIPMENT : Mobile phone
BRAND NAME : BLU
MODEL NAME : Dash 4.5
MARKETING NAME : Dash 4.5
FCC ID : YHLBLUDASH45
STANDARD : FCC Part 15 Subpart C §15.247
CLASSIFICATION : (DTS) Digital Transmission System

The product was received on Apr. 25, 2013 and completely tested on May 09, 2013. We, SPORTON INTERNATIONAL (KUNSHAN) INC., would like to declare that the tested sample has been evaluated in accordance with the procedures and shown the compliance with the applicable technical standards.

The test results in this report apply exclusively to the tested model / sample. Without written approval of SPORTON INTERNATIONAL (KUNSHAN) INC., the test report shall not be reproduced except in full.

Reviewed by:



Jones Tsai / Manager



SPORTON INTERNATIONAL (KUNSHAN) INC.
No. 3-2, PingXiang Road, Kunshan, Jiangsu Province, P.R.C.



TABLE OF CONTENTS

REVISION HISTORY..... 3

SUMMARY OF TEST RESULT 4

1 GENERAL DESCRIPTION..... 5

 1.1 Applicant..... 5

 1.2 Manufacturer..... 5

 1.3 Feature of Equipment Under Test..... 5

 1.4 Product Specification of Equipment Under Test..... 5

 1.5 Testing Site..... 6

 1.6 Applied Standards 6

2 TEST CONFIGURATION OF EQUIPMENT UNDER TEST..... 7

 2.1 Descriptions of Test Mode..... 7

 2.2 Test Mode..... 8

 2.3 Connection Diagram of Test System..... 9

 2.4 Support Unit used in test configuration and system 10

 2.5 Description of RF Function Operation Test Setup..... 10

 2.6 Measurement Results Explanation Example..... 10

3 TEST RESULT 11

 3.1 6dB Bandwidth Measurement 11

 3.2 Peak Output Power Measurement 14

 3.3 Power Spectral Density Measurement 16

 3.4 Conducted Band Edges and Spurious Emission Measurement 22

 3.5 Radiated Band Edges and Spurious Emission Measurement 30

 3.6 AC Conducted Emission Measurement..... 47

 3.7 Antenna Requirements..... 51

4 LIST OF MEASURING EQUIPMENT..... 52

5 UNCERTAINTY OF EVALUATION..... 53

APPENDIX A. PHOTOGRAPHS OF EUT

APPENDIX B. SETUP PHOTOGRAPHS



REVISION HISTORY

REPORT NO.	VERSION	DESCRIPTION	ISSUED DATE
FR342511B	Rev. 01	Initial issue of report	Jun. 01, 2013

SUMMARY OF TEST RESULT

Report Section	FCC Rule	Description	Limit	Result	Remark
3.1	15.247(a)(2)	6dB Bandwidth	$\geq 0.5\text{MHz}$	Pass	-
3.2	15.247(b)(1)	Peak Output Power	$\leq 30\text{dBm}$	Pass	-
3.5	15.247(e)	Power Spectral Density	$\leq 8\text{dBm}$	Pass	-
3.4	15.247(d)	Conducted Band Edges and Spurious Emission	$\leq 20\text{dBc}$	Pass	-
3.5	15.247(d)	Radiated Band Edges and Spurious Emission	15.209(a) & 15.247(d)	Pass	Under limit 9.69 dB at 835.100 MHz
3.6	15.207	AC Conducted Emission	15.207(a)	Pass	Under limit 7.58 dB at 0.370 MHz
3.7	15.203 & 15.247(b)	Antenna Requirement	N/A	Pass	-

1 General Description

1.1 Applicant

CT Asia

Unit 01, 15/F, Seaview Centre, 139-141 Hoi bun road, Kwun Tong, Kowloon, Hongkong

1.2 Manufacturer

Ragentek Technology Group

Building D10-D11, No. 58-60, Lane 3188, Xiupu Road, PuDong District, Shanghai, PRC

1.3 Feature of Equipment Under Test

Product Feature	
Equipment	Mobile phone
Brand Name	BLU
Model Name	Dash 4.5
Marketing Name	Dash 4.5
FCC ID	YHLBLUDASH45
EUT supports Radios application	GSM/GPRS/WCDMA/HSPA/HSPA+/WLAN 11bgn/Bluetooth/Bluetooth v4.0 - LE
HW Version	V1.2
SW Version	BLU-D310-V05-GENERIC
EUT Stage	Identical Prototype

Remark: The above EUT's information was declared by manufacturer. Please refer to the specifications or user's manual for more detailed description.

1.4 Product Specification of Equipment Under Test

Product Specification subjective to this standard	
Tx/Rx Frequency Range	2402 MHz ~ 2480 MHz
Number of Channels	40
Carrier Frequency of Each Channel	2402+n*2 MHz; n=0~39
Maximum Output Power to Antenna	Bluetooth v4.0 - LE : -0.20 dBm (0.0010 W)
Antenna Type	Monopole Antenna type with gain 0 dBi
Type of Modulation	Bluetooth v4.0 - LE : GFSK

1.5 Testing Site

Test Site	SPORTON INTERNATIONAL (KUNSHAN) INC.	
Test Site Location	No. 3-2, PingXiang Road, Kunshan, Jiangsu Province, P.R.C. TEL: +86-0512-5790-0158 FAX: +86-0512-5790-0958	
Test Site No.	Sporton Site No.	FCC/IC Registration No.
	03CH01-KS	149928/4086E-1

Test Site	SPORTON INTERNATIONAL (SHENZHEN) INC.	
Test Site Location	No. 3 Building, the third floor of south, Shahe River west, Fengzeyuan warehouse, Nanshan District, Shenzhen, Guangdong, P.R.C. TEL: +86-755- 3320-2398	
Test Site No.	Sporton Site No.	FCC/IC Registration No.
	TH01-SZ	CO01-SZ
		831040/4086F-1

The test site complies with ANSI C63.4 2003 requirement.

1.6 Applied Standards

According to the specifications of the manufacturer, the EUT must comply with the requirements of the following standards:

- ♦ FCC Part 15 Subpart C §15.247
- ♦ FCC KDB Publication No. 558074 D01 DTS Meas. Guidance v03r01
- ♦ ANSI C63.10-2009

Remark:

1. All test items were verified and recorded according to the standards and without any deviation during the test.
2. This EUT has also been tested and complied with the requirements of FCC Part 15, Subpart B, recorded in a separate test report.

2 Test Configuration of Equipment Under Test

2.1 Descriptions of Test Mode

The RF output power was recorded in the following table:

Channel	Frequency	Bluetooth 4.0 – LE RF Output Power
		Data Rate / Modulation
		GFSK
		1Mbps
Ch00	2402MHz	-2.22 dBm
Ch19	2440MHz	-1.55 dBm
Ch39	2480MHz	-0.20 dBm

- a. The EUT has been associated with peripherals pursuant to ANSI C63.4-2003 and ANSI C63.10-2009 and configuration operated in a manner tended to maximize its emission characteristics in a typical application. Frequency range investigated: conduction (150 KHz to 30 MHz), radiation (9 KHz to the 10th harmonic of the highest fundamental frequency or to 40 GHz, whichever is lower). Pre-scanned tests, X, Y, Z in three orthogonal panels to determine the final configuration (Y plane as worst plane) from all possible combinations.
- b. AC power line Conducted Emission was tested under maximum output power.

2.2 Test Mode

The following summary table is showing all test modes to demonstrate in compliance with the standard.

Summary table of Test Cases	
Test Item	Data Rate / Modulation
	Bluetooth 4.0 – LE / GFSK
Conducted TCs	Mode 1: Bluetooth Tx CH00_2402 MHz_1Mbps Mode 2: Bluetooth Tx CH19_2440 MHz_1Mbps Mode 3: Bluetooth Tx CH39_2480 MHz_1Mbps
Radiated TCs	Mode 1: Bluetooth Tx CH00_2402 MHz_1Mbps Mode 2: Bluetooth Tx CH19_2440 MHz_1Mbps Mode 3: Bluetooth Tx CH39_2480 MHz_1Mbps
AC Conducted Emission	Mode 1 :GSM850 Idle + Bluetooth Link + WLAN Link + USB Cable (Charging from Adapter) + Earphone

2.3 Connection Diagram of Test System

<Bluetooth 4.0 – LE Tx Mode>

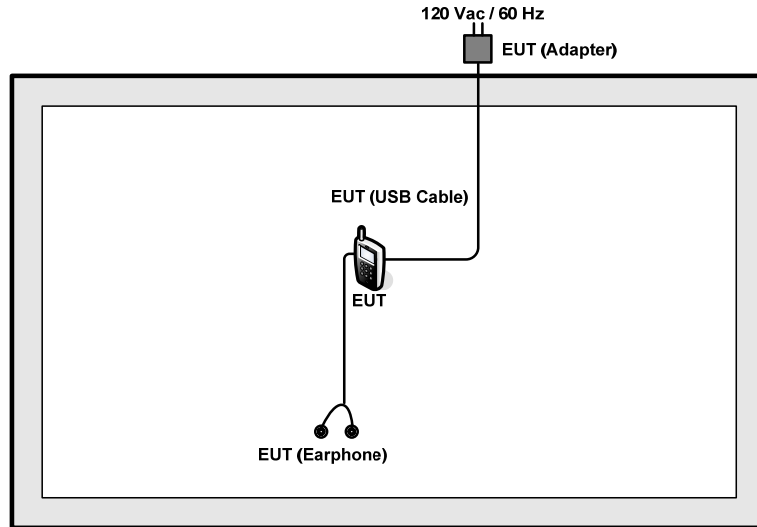

<AC Conducted Emission Mode>

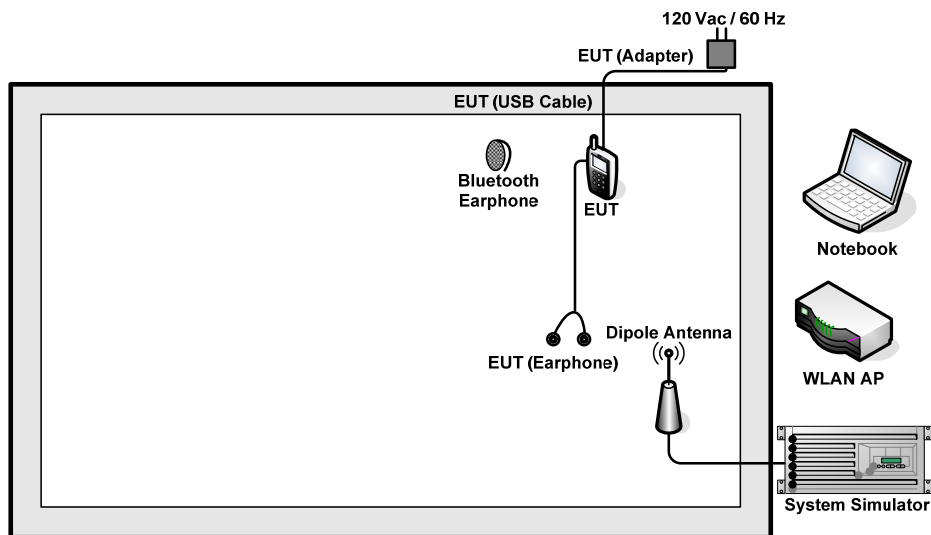

2.4 Support Unit used in test configuration and system

Item	Equipment	Trade Name	Model Name	FCC ID	Data Cable	Power Cord
1.	System Simulator	Agilent	E5515C	N/A	N/A	Unshielded, 1.8 m
2.	DC Power Supply	TOPWORD	3303DR	N/A	N/A	Unshielded, 1.8 m
3.	WLAN AP	Netcore	NW616	N/A	N/A	Unshielded, 1.8 m
4.	Notebook	DELL	P08S	QDS-BRCM1030	N/A	AC I/P: Unshielded, 1.8 m DC O/P: Shielded, 1.8 m
5.	Bluetooth Earphone	Nokia	BH-108	N/A	N/A	N/A

2.5 Description of RF Function Operation Test Setup

For Bluetooth function, the engineering test program was provided and enabled to make EUT continuous transmit/receive.

2.6 Measurement Results Explanation Example

For conducted test items:

The offset level is set in the spectrum analyzer to compensate the RF cable loss and 10dB attenuator between EUT conducted output port and spectrum analyzer. With the offset compensation, the spectrum analyzer reading level is exactly the EUT RF output level.

The spectrum analyzer offset is derived from RF cable loss and 10dB attenuator factor.

Offset = RF cable loss + attenuator factor.

Following table shows an offset computation example with cable loss 5.60 dB.

Example :

$$\begin{aligned} \text{Offset}(dB) &= \text{RF cable loss}(dB) + \text{attenuator factor}(dB). \\ &= 7.50 + 10 = 17.50 \text{ (dB)} \end{aligned}$$

3 Test Result

3.1 6dB Bandwidth Measurement

3.1.1 Limit of 6dB Bandwidth

The minimum 6 dB bandwidth shall be at least 500 KHz.

3.1.2 Measuring Instruments

See list of measuring instruments of this test report.

3.1.3 Test Procedures

1. The testing follows FCC KDB Publication No. 558074 D01 DTS Meas. Guidance v03r01.
2. The RF output of EUT was connected to the spectrum analyzer by RF cable and attenuator. The path loss was compensated to the results for each measurement.
3. Set to the maximum power setting and enable the EUT transmit continuously.
4. Make the measurement with the spectrum analyzer's resolution bandwidth (RBW) = 100 kHz. Set the Video bandwidth (VBW) = 300 kHz. In order to make an accurate measurement. The 6 dB bandwidth must be greater than 500 kHz.
5. Measure and record the results in the test report.

3.1.4 Test Setup

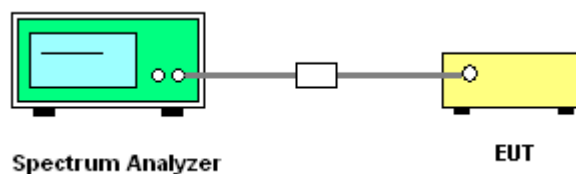

3.1.5 Test Result of 6dB Bandwidth

Test Mode :	Bluetooth 4.0 - LE	Temperature :	24~25°C
Test Engineer :	Fly Chen	Relative Humidity :	50~53%

Channel	Frequency (MHz)	6dB Bandwidth (MHz)
00	2402	0.7004
19	2440	0.7004
39	2480	0.7004

6 dB Bandwidth Plot on Channel 00

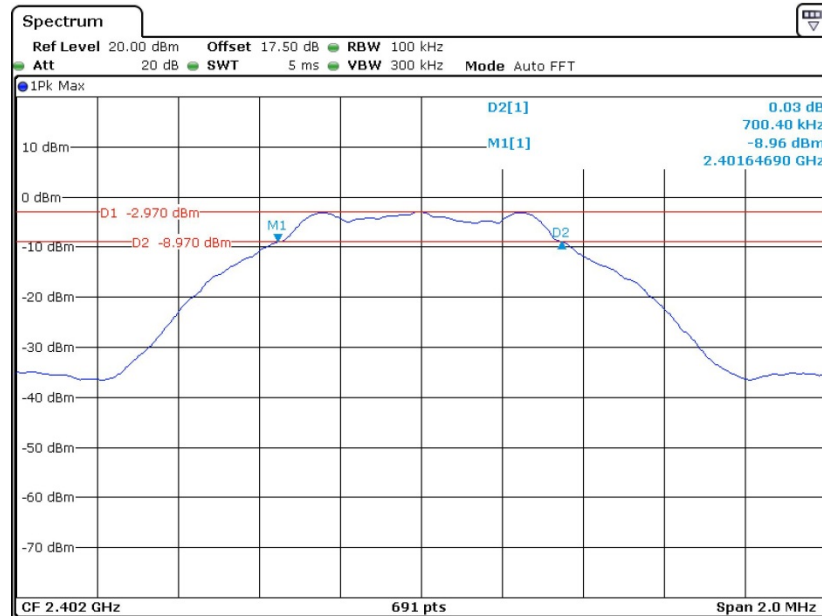

Date: 5.MAY.2013 09:03:06

6 dB Bandwidth Plot on Channel 19

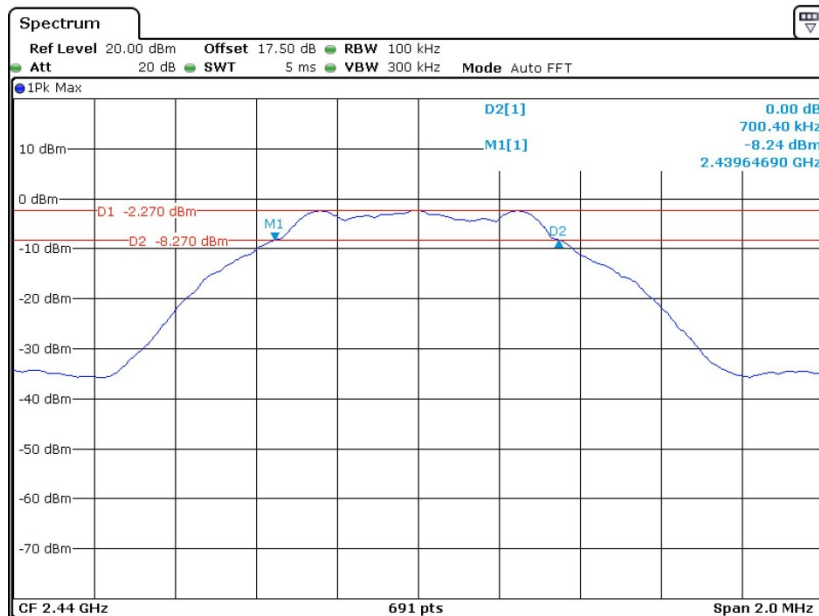

Date: 5.MAY.2013 09:04:14

6 dB Bandwidth Plot on Channel 39

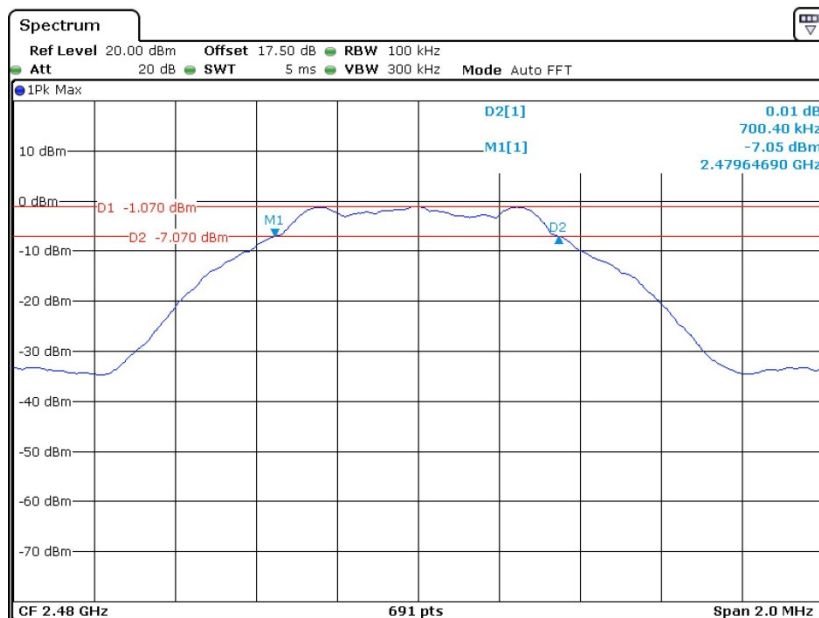

Date: 5.MAY.2013 09:06:08

3.2 Peak Output Power Measurement

3.2.1 Limit of Peak Output Power

For systems using digital modulation in the 2400-2483.5MHz, the limit for peak output power is 30dBm. If transmitting antenna of directional gain greater than 6dBi is used, the peak output power from the intentional radiator shall be reduced below the above stated value by the amount in dB that the directional gain of the antenna exceeds 6 dBi. In case of point-to-point operation, the limit has to be reduced by 1dB for every 3dB that the directional gain of the antenna exceeds 6dBi.

3.2.2 Measuring Instruments

See list of measuring instruments of this test report.

3.2.3 Test Procedures

1. The testing follows the Measurement Procedure of FCC KDB No. 558074 D01 DTS Meas. Guidance v03r01.
2. The RF output of EUT was connected to the power meter by RF cable and attenuator. The path loss was compensated to the results for each measurement.
3. Set to the maximum power setting and enable the EUT transmit continuously.
4. Measure the conducted output power and record the results in the test report.

3.2.4 Test Setup

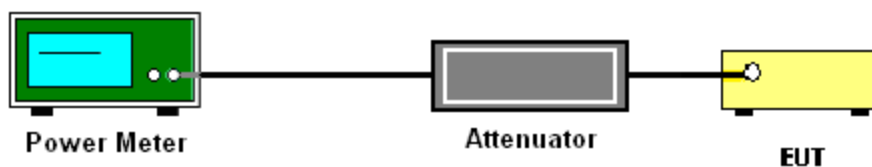



3.2.5 Test Result of Peak Output Power

Test Mode :	Bluetooth 4.0 - LE	Temperature :	24~25°C
Test Engineer :	Fly Chen	Relative Humidity :	50~53%

Channel	Frequency (MHz)	RF Power (dBm)		
		GFSK	Max. Limits (dBm)	Pass/Fail
00	2402	-2.22	30.00	Pass
19	2440	-1.55	30.00	Pass
39	2480	-0.20	30.00	Pass

3.3 Power Spectral Density Measurement

3.3.1 Limit of Power Spectral Density

The peak power spectral density shall not be greater than 8dBm in any 3kHz band at any time interval of continuous transmission.

3.3.2 Measuring Instruments

See list of measuring instruments of this test report.

3.3.3 Test Procedures

1. The testing follows Measurement Procedure 10.2 Option 1 of FCC KDB Publication No. 558074 D01 DTS Meas. Guidance v03r01
2. The RF output of EUT was connected to the spectrum analyzer by RF cable and attenuator. The path loss was compensated to the results for each measurement.
3. Set to the maximum power setting and enable the EUT transmit continuously.
4. Make the measurement with the spectrum analyzer's resolution bandwidth (RBW) = 3 kHz. Video bandwidth VBW = 10 kHz In order to make an accurate measurement, set the span to 1.5 times DTS Channel Bandwidth. (6dB BW)
5. Detector = peak, Sweep time = auto couple, Trace mode = max hold, Allow trace to fully stabilize. Use the peak marker function to determine the maximum power level.
6. Measure and record the results in the test report.
7. The Measured power density (dBm)/ 100 kHz is a reference level and used as 20dBc down limit line for Conducted Band Edges and Conducted Spurious Emission.

3.3.4 Test Setup

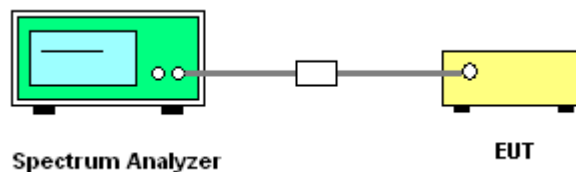

3.3.5 Test Result of Power Spectral Density

Test Mode :	Bluetooth 4.0 - LE	Temperature :	24~25°C
Test Engineer :	Fly Chen	Relative Humidity :	50~53%

Channel	Frequency (MHz)	Power Density		Max. Limits (dBm/3kHz)	Pass/Fail
		PSD/100kHz (dBm)	PSD/3kHz (dBm)		
00	2402	-2.98	-17.81	8	Pass
19	2440	-2.28	-17.11	8	Pass
39	2480	-1.08	-15.90	8	Pass

Note:

1. Measured power density (dBm) has offset with cable loss.
2. The Measured power density (dBm)/ 100kHz is reference level and used as 20dBc down for Conducted Band Edges and Conducted Spurious Emission limit line.



3.3.6 Test Result of Power Spectral Density Plots (100kHz)

PSD 100kHz Plot on Channel 00

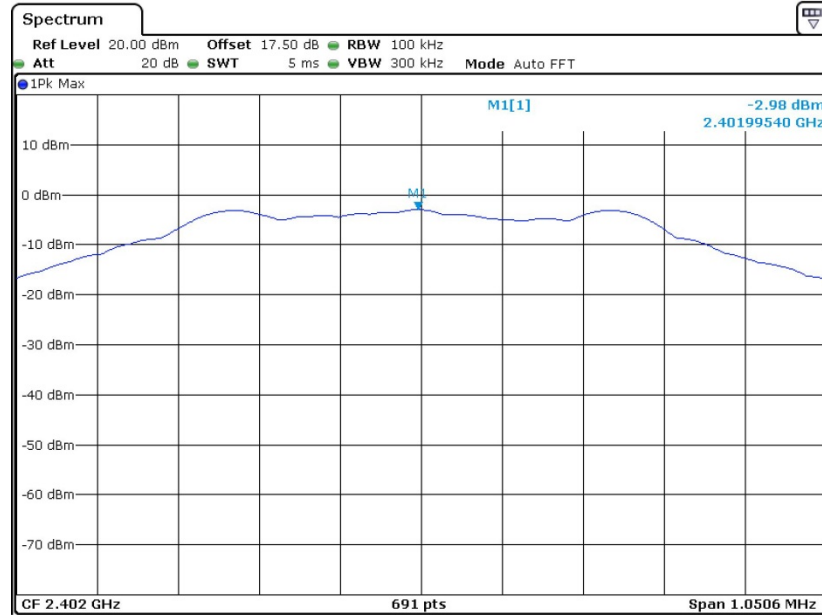

Date: 5.MAY.2013 09:15:15

PSD 100kHz Plot on Channel 19

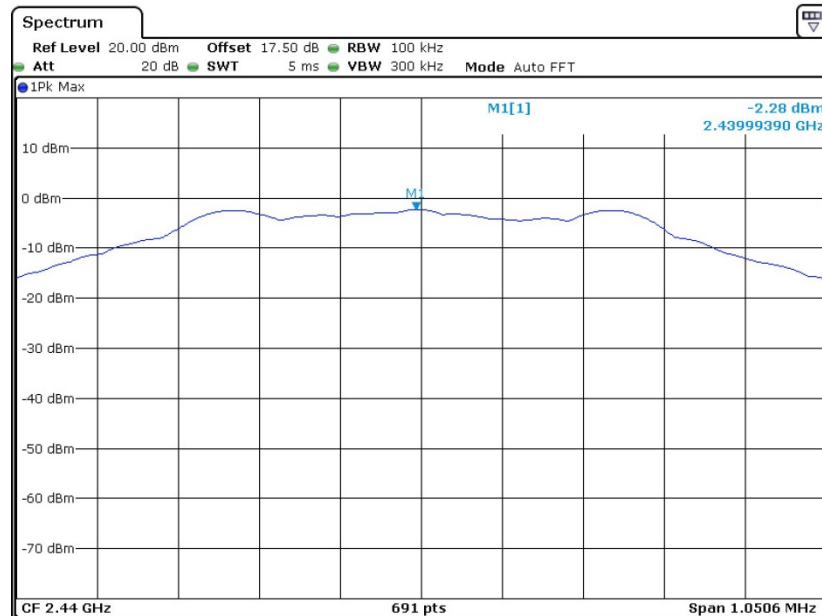

Date: 5.MAY.2013 09:14:35



PSD 100kHz Plot on Channel 39

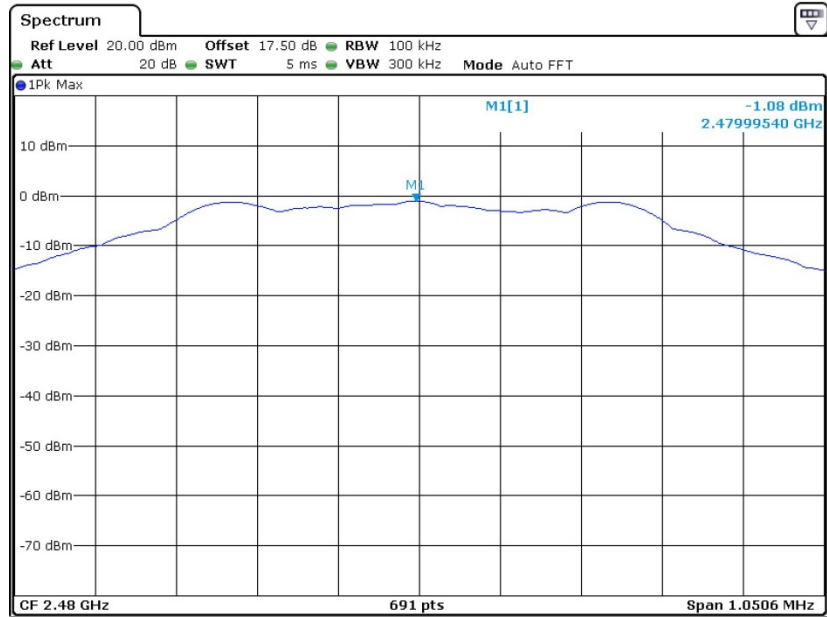

Date: 5.MAY.2013 09:13:55



3.3.7 Test Result of Power Spectral Density Plots (3kHz)

PSD 3kHz Plot on Channel 00

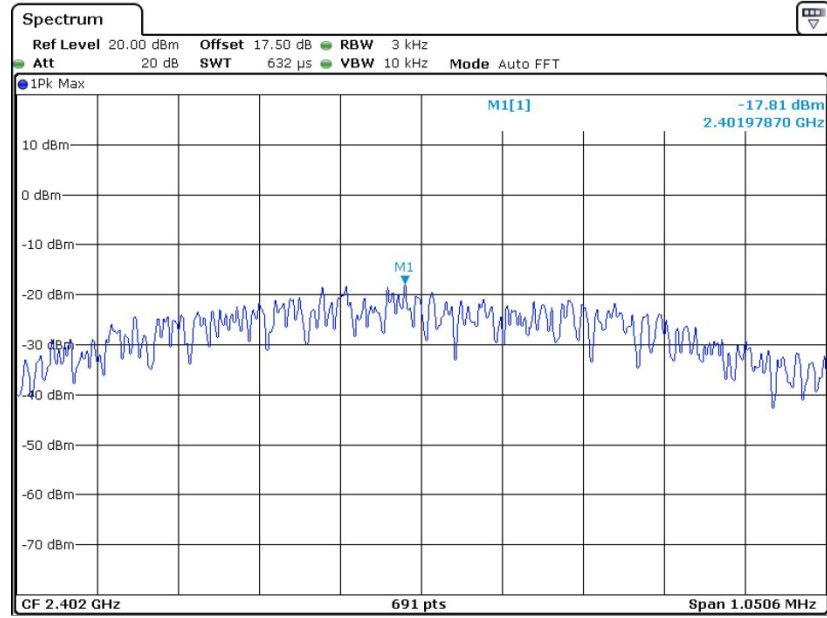

Date: 5.MAY.2013 09:19:05

PSD 3kHz Plot on Channel 19

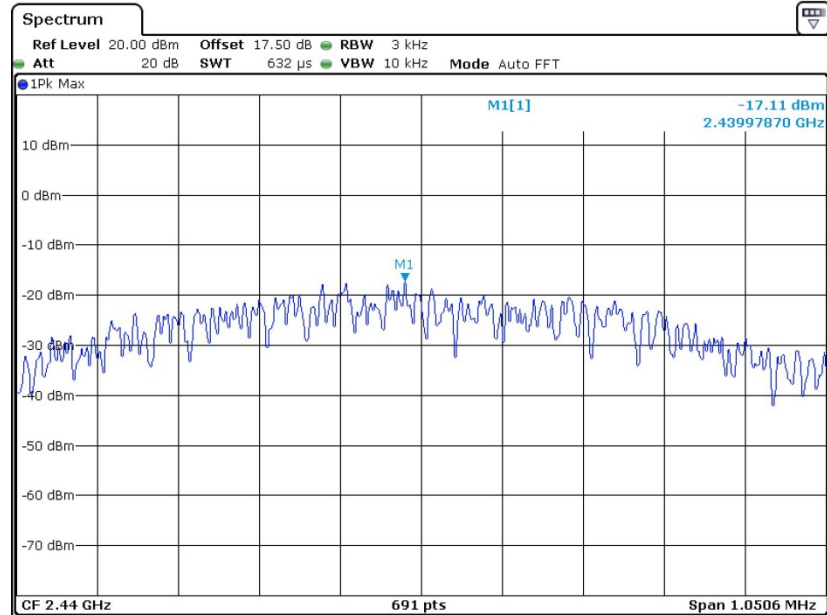

Date: 5.MAY.2013 09:20:04



PSD 3kHz Plot on Channel 39

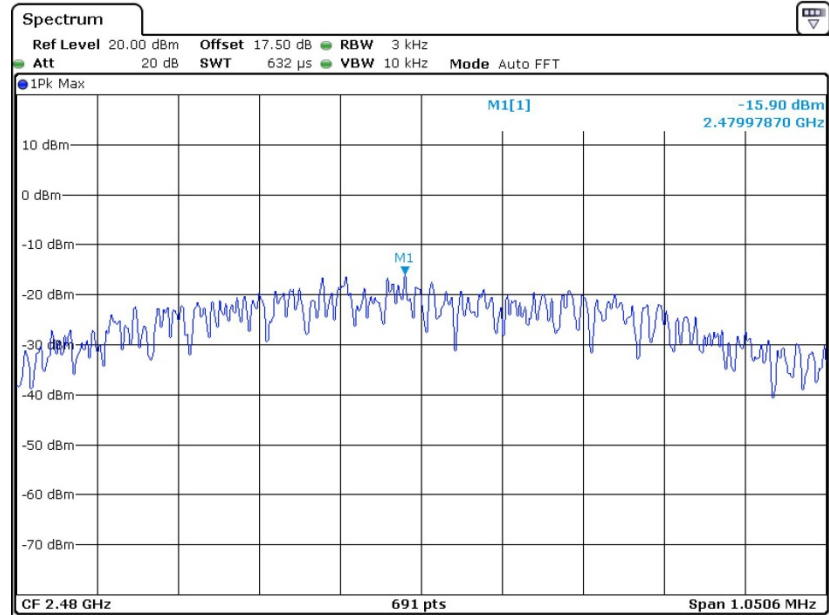

Date: 5.MAY.2013 09:20:29

3.4 Conducted Band Edges and Spurious Emission Measurement

3.4.1 Limit of Conducted Band Edges and Spurious Emission

All harmonics/spurious must be at least 20 dB down from the highest emission level within the authorized band.

3.4.2 Measuring Instruments

See list of measuring instruments of this test report.

3.4.3 Test Procedure

1. The testing follows FCC KDB Publication No. 558074 D01 DTS Meas. Guidance v03r01.
2. The RF output of EUT was connected to the spectrum analyzer by RF cable and attenuator. The path loss was compensated to the results for each measurement.
3. Set to the maximum power setting and enable the EUT transmit continuously.
4. Set RBW = 100 kHz, VBW=300 kHz, Peak Detector. Unwanted Emissions measured in any 100 kHz bandwidth outside of the authorized frequency band shall be attenuated by at least 20 dB relative to the maximum in-band peak PSD level in 100 kHz when maximum peak conducted output power procedure is used. If the transmitter complies with the conducted power limits based on the use of RMS averaging over a time interval, the attenuation required under this paragraph shall be 30 dB instead of 20 dB per 15.247(d).
5. Measure and record the results in the test report.
6. The RF fundamental frequency should be excluded against the limit line in the operating frequency band.

3.4.4 Test Setup

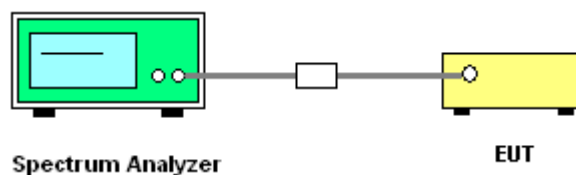



3.4.5 Test Result of Conducted Band Edges

Test Mode :	Bluetooth 4.0 - LE	Temperature :	24~25°C
Test Channel :	00 and 39	Relative Humidity :	50~53%
		Test Engineer :	Fly Chen

Low Band Edge Plot on Channel 00

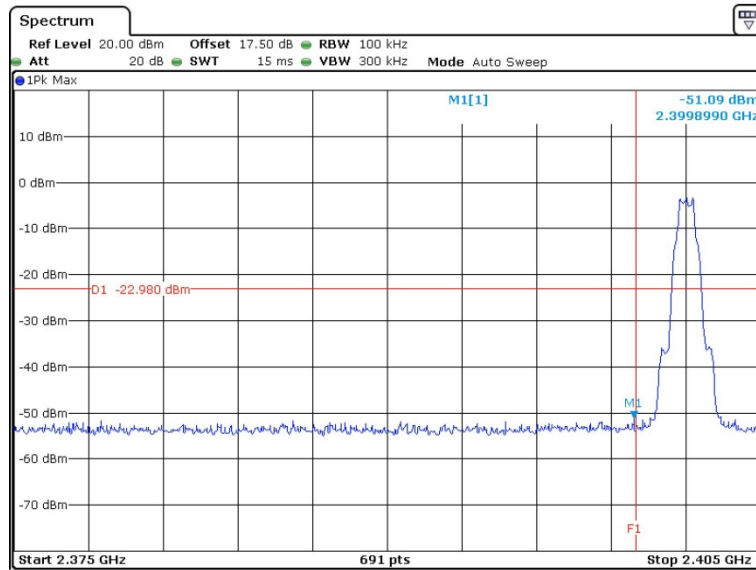

Date: 5.MAY.2013 10:27:56

High Band Edge Plot on Channel 39

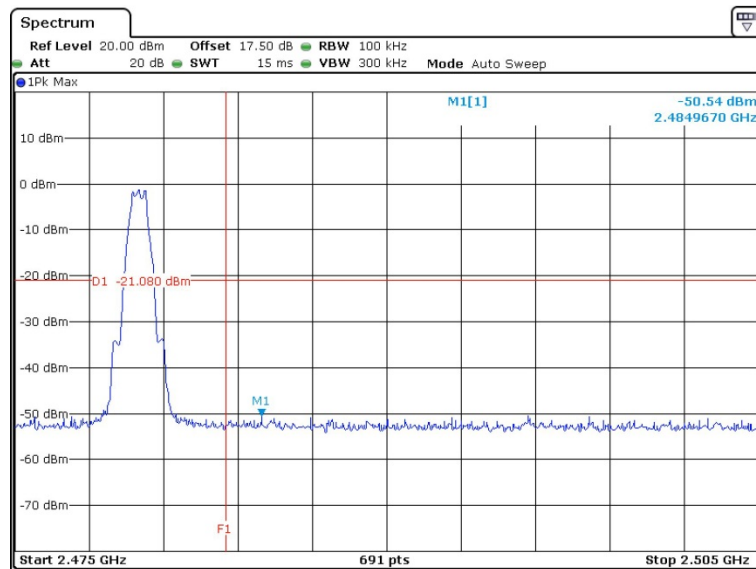

Date: 5.MAY.2013 10:26:18



3.4.6 Test Result of Conducted Spurious Emission

Test Mode :	Bluetooth 4.0 - LE	Temperature :	24~25°C
Test Channel :	00	Relative Humidity :	50~53%
		Test Engineer :	Fly Chen

Conducted Spurious Emission Plot on Bluetooth LE

GFSK Channel 00

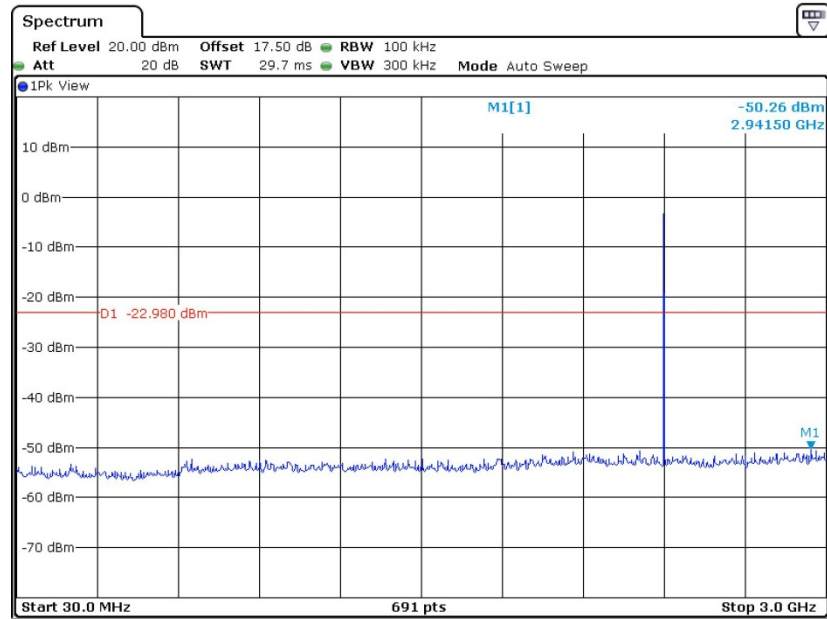

Date: 5.MAY.2013 10:29:07



Conducted Spurious Emission Plot on Bluetooth LE
GFSK Channel 00

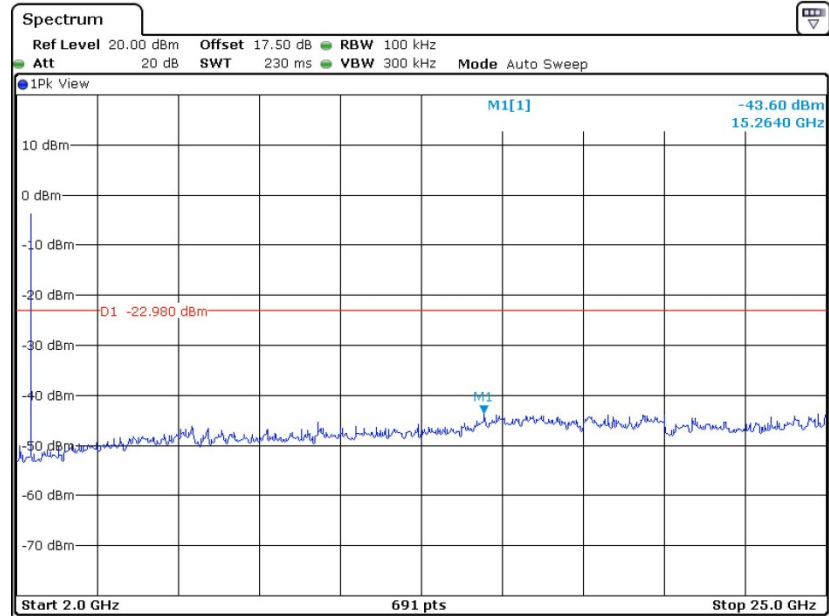

Date: 5.MAY.2013 10:29:50



Test Mode :	Bluetooth 4.0 - LE	Temperature :	24~25°C
Test Channel :	19	Relative Humidity :	50~53%
		Test Engineer :	Fly Chen

Conducted Spurious Emission Plot on Bluetooth LE
GFSK Channel 19

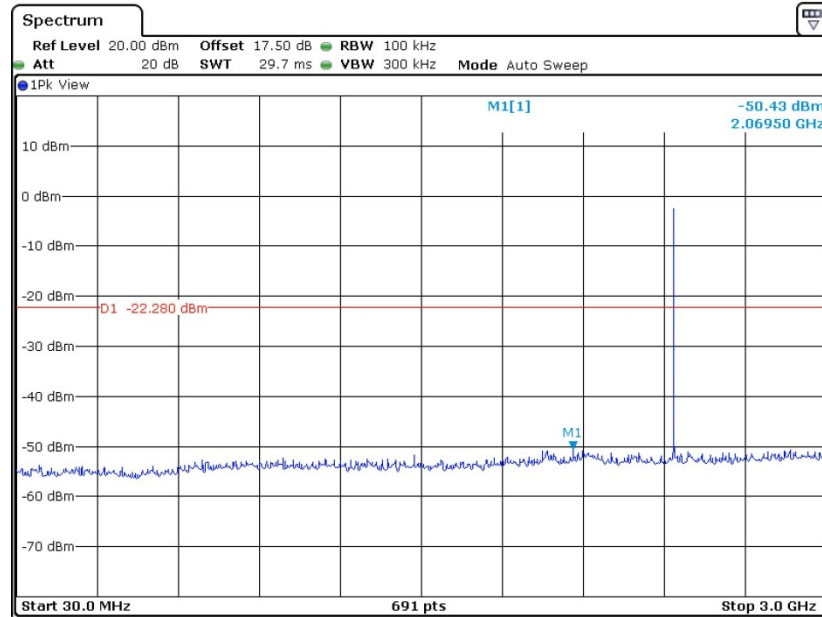

Date: 5.MAY.2013 10:30:33



Conducted Spurious Emission Plot on Bluetooth LE
GFSK Channel 19

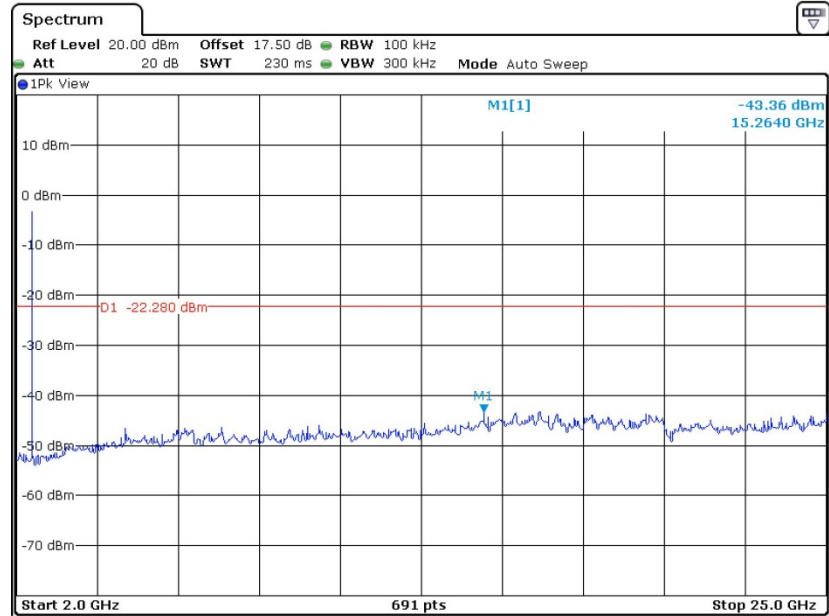

Date: 5.MAY.2013 10:31:07



Test Mode :	Bluetooth 4.0 - LE	Temperature :	24~25°C
Test Channel :	39	Relative Humidity :	50~53%
		Test Engineer :	Fly Chen

Conducted Spurious Emission Plot on Bluetooth LE
GFSK Channel 39

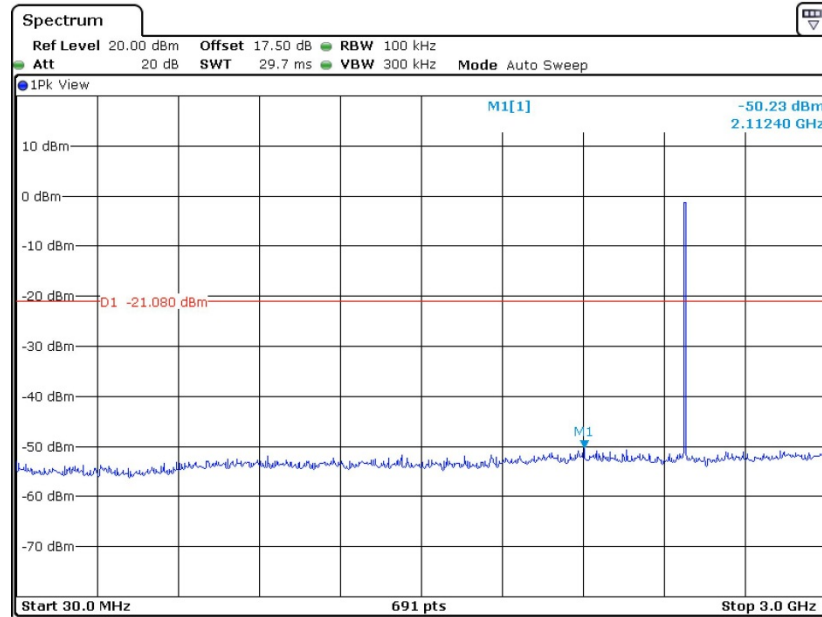

Date: 5.MAY.2013 10:32:06



Conducted Spurious Emission Plot on Bluetooth LE
GFSK Channel 39

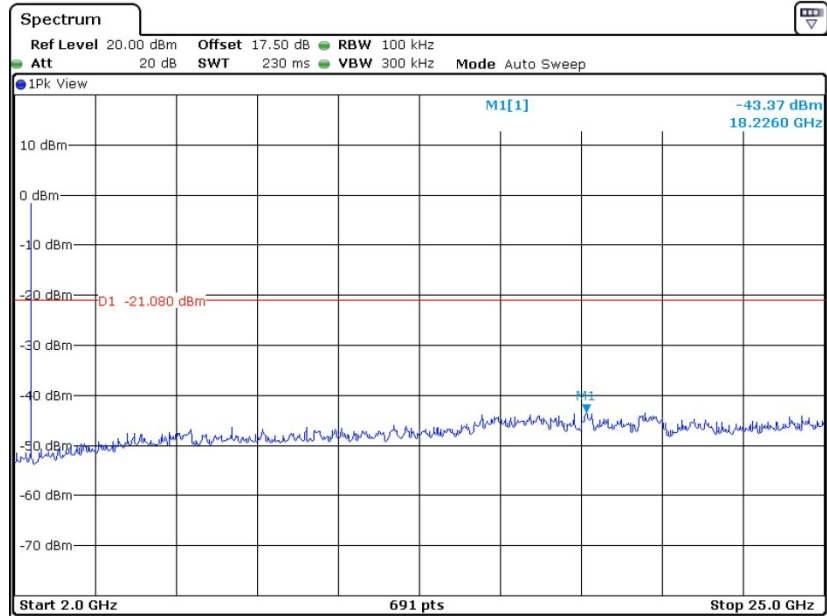

Date: 5.MAY.2013 10:32:48

3.5 Radiated Band Edges and Spurious Emission Measurement

3.5.1 Limit of Radiated Band Edges and Spurious Emission

In any 100 kHz bandwidth outside the intentional radiator frequency band, all harmonics/spurious must be at least 20 dB below the highest emission level within the authorized band. If the output power of this device was measured by spectrum analyzer, the attenuation under this paragraph shall be 30 dB instead of 20 dB. In addition, radiated emissions which fall in the restricted bands must also comply with the FCC section 15.209 limits as below.

Frequency (MHz)	Field Strength (microvolts/meter)	Measurement Distance (meters)
0.009 – 0.490	2400/F(kHz)	300
0.490 – 1.705	24000/F(kHz)	30
1.705 – 30.0	30	30
30 – 88	100	3
88 – 216	150	3
216 - 960	200	3
Above 960	500	3

3.5.2 Measuring Instruments

See list of measuring instruments of this test report.

3.5.3 Test Procedures

1. The testing follows the guidelines in ANSI C63.10-2009 and ANSI C63.4-2003 test site requirement.
2. The EUT was arranged to its worst case and then tune the antenna tower (from 1 m to 4 m) and turntable (from 0 degree to 360 degrees) to find the maximum reading. A pre-amp and a high pass filter are used for the test in order to get better signal level.
3. The EUT was placed on a turntable with 0.8 meter above ground.
4. The EUT was set 3 meters from the interference receiving antenna, which was mounted on the top of a variable height antenna tower.
5. Corrected Reading: Antenna Factor + Cable Loss + Read Level - Preamp Factor = Level
6. For measurement below 1GHz, If the emission level of the EUT measured by the peak detector is 3 dB lower than the applicable limit, the peak emission level will be reported. Otherwise, the emission measurement will be repeated using the quasi-peak detector and reported.
7. Use the following spectrum analyzer settings:
 - (1) Span shall wide enough to fully capture the emission being measured;
 - (2) Set RBW=100 kHz for $f < 1$ GHz; $VBW \geq RBW$; Sweep = auto; Detector function = peak; Trace = max hold;
 - (3) Set RBW = 1 MHz, VBW= 3MHz for $f \geq 1$ GHz for peak measurement.
 For average measurement:
 - $VBW = 10$ Hz, when duty cycle is no less than 98 percent.
 - $VBW \geq 1/T$, when duty cycle is less than 98 percent where T is the minimum transmission duration over which the transmitter is on and is transmitting at its maximum power control level for the tested mode of operation.

Band	Duty Cycle(%)	T(ms)	1/T(kHz)	VBW Setting
Bluetooth 4.0 - LE	64.269	0.401	2.491	3kHz

Note: For average measurement with duty cycle < 98%, use reduced VBW measurement method 4.2.3.2.3 in ANSI C63.10.



Duty Cycle

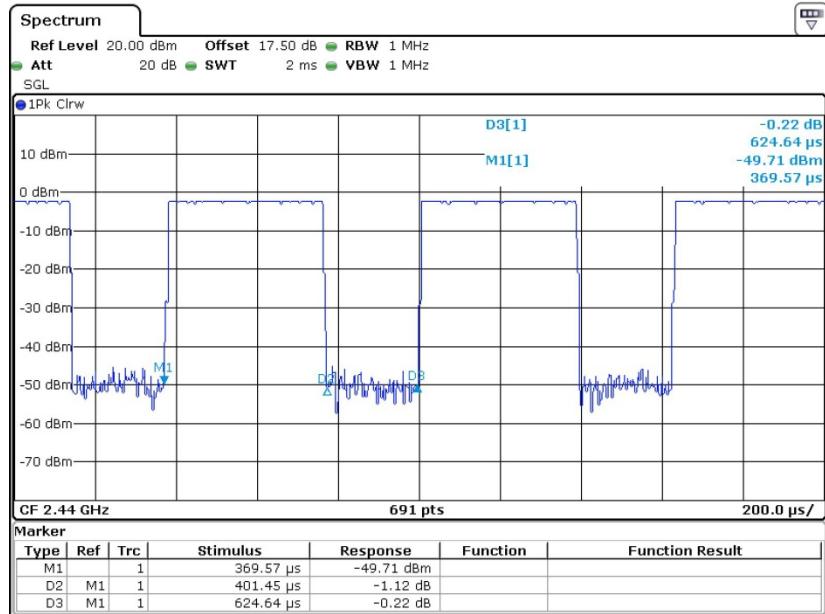

Date: 3.MAY.2013 06:07:51

Note:

The total loss is 17.5dB of the RF cable and attenuator, and has been compensated to the spectrum analyzer by setting into the amplitude level offset. That means the measured result shown on the spectrum analyzer has added the total loss and been compliance with the limit line.



Marker-Delta method :

- (1) Set RBW = 1 MHz, VBW = 3 MHz, peak detector.

Repeat the measurement with an average detector, use RBW = 1MHz

VBW = 10 Hz, when duty cycle is no less than 98 percent.

VBW \geq 1/T, when duty cycle is less than 98 percent

- (2) Set span = 10MHz, that encompasses both the peak of the fundamental emission and the band-edge emission under investigation. Set RBW = 100kHz, 1% of the total span. Set VBW = 100kHz \geq RBW.

- (3) Subtract the delta measured in step (2) from the field strengths measured in step (1).

The resultant field strengths (peak/average) are then used to determine band-edge compliance as required by Section 15.205.

3.5.4 Test Setup

For radiated emissions below 30MHz

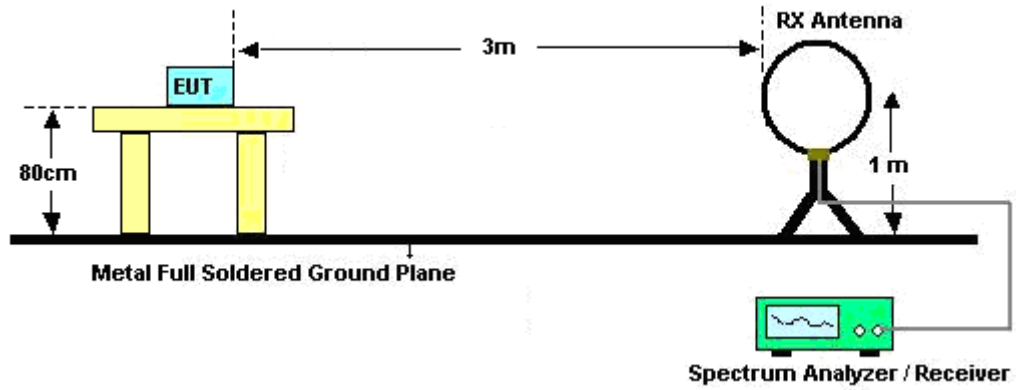

For radiated emissions from 30MHz to 1GHz

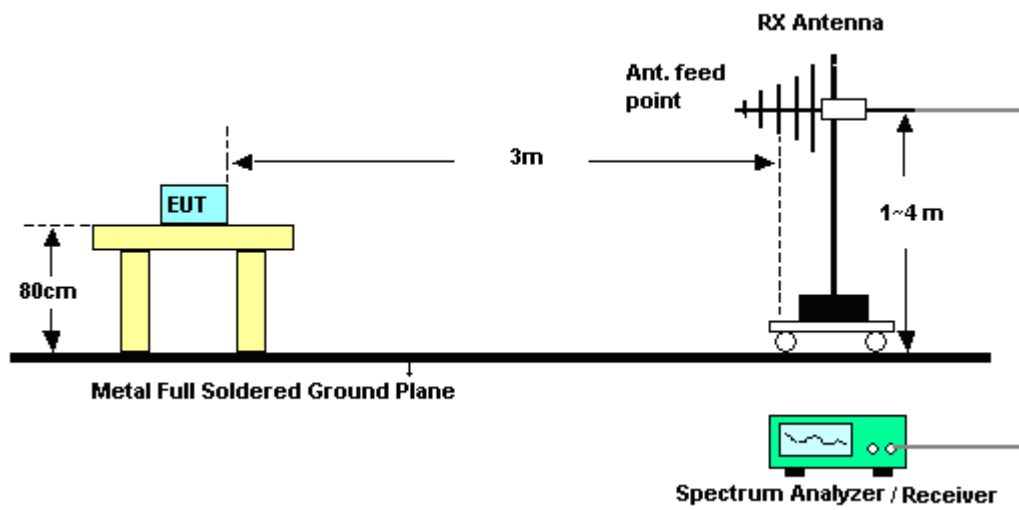

For radiated emissions above 1GHz

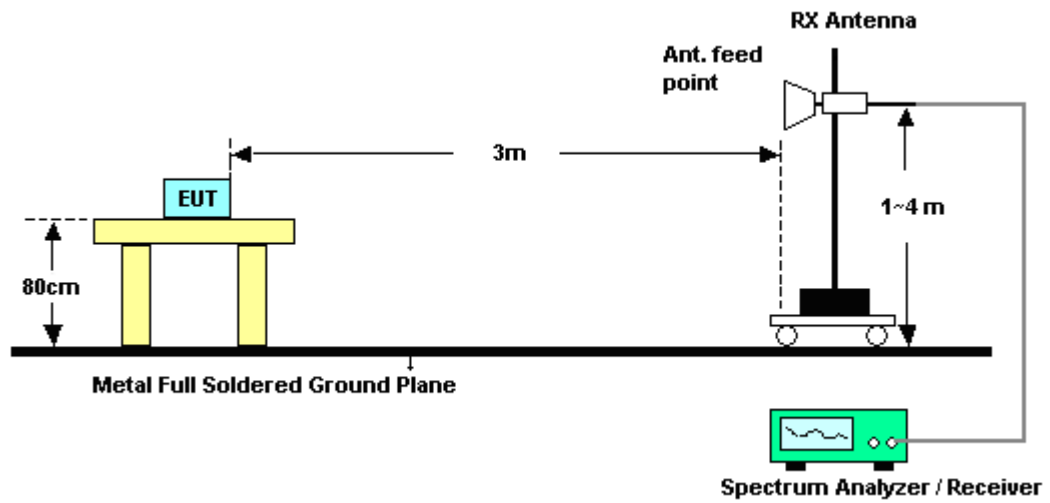

3.5.5 Test Results of Radiated Spurious Emission (9 kHz ~ 30 MHz)

The low frequency, which started from 9 kHz to 30MHz, was pre-scanned and the result which was 20dB lower than the limit line per 15.31(o) was not reported.



3.5.6 Test Result of Radiated Band Edges

Test Mode :	Mode 1	Temperature :	23~24°C
Test Channel :	00	Relative Humidity :	43~44%
		Test Engineer :	Stone Gu

ANTENNA POLARITY : HORIZONTAL										
Frequency (MHz)	Level (dBuV/m)	Over Limit (dB)	Limit Line (dBuV/m)	Read Level (dBuV)	Antenna Factor (dB)	Cable Loss (dB)	Preamp Factor (dB)	Ant Pos (cm)	Table Pos (deg)	Remark
2385.78	49.72	-24.28	74	46.26	32.86	2.11	31.51	167	75	Peak
2386.14	38.3	-15.7	54	34.84	32.86	2.11	31.51	167	75	Average

ANTENNA POLARITY : VERTICAL										
Frequency (MHz)	Level (dBuV/m)	Over Limit (dB)	Limit Line (dBuV/m)	Read Level (dBuV)	Antenna Factor (dB)	Cable Loss (dB)	Preamp Factor (dB)	Ant Pos (cm)	Table Pos (deg)	Remark
2386.32	50.73	-23.27	74	47.27	32.86	2.11	31.51	101	143	Peak
2385.78	38.71	-15.29	54	35.25	32.86	2.11	31.51	101	143	Average



Test Mode :	Mode 3	Temperature :	23~24°C
Test Channel :	39	Relative Humidity :	43~44%
		Test Engineer :	Stone Gu

ANTENNA POLARITY : HORIZONTAL										
Frequency (MHz)	Level (dBuV/m)	Over Limit (dB)	Limit Line (dBuV/m)	Read Level (dBuV)	Antenna Factor (dB)	Cable Loss (dB)	Preamp Factor (dB)	Ant Pos (cm)	Table Pos (deg)	Remark
2483.5	58.94	-15.06	74	55.28	33.01	2.16	31.51	107	45	Peak
2483.5	55.5	1.5	54	51.84	33.01	2.16	31.51	107	45	Average
2483.5	42.96	-31.04	74	-	-	-	-	-	-	Peak
2483.5	41.63	-12.37	54	-	-	-	-	-	-	Average

Summary results of marker-delta method:

Test mode	Maximum field strength of the fundamental emission (dBµV/m)	Delta Result (dB)	Measurement Result (dBµV/m)	Limit (dBµV/m)	Margin (dB)	Result
Peak	97.55	54.59	42.96	74	-31.04	Pass
Average	96.22	54.59	41.63	54	-12.37	Pass

Note : Measurement result = Maximum field strength – Delta result

ANTENNA POLARITY : VERTICAL										
Frequency (MHz)	Level (dBuV/m)	Over Limit (dB)	Limit Line (dBuV/m)	Read Level (dBuV)	Antenna Factor (dB)	Cable Loss (dB)	Preamp Factor (dB)	Ant Pos (cm)	Table Pos (deg)	Remark
2483.5	57.31	-16.69	74	53.65	33.01	2.16	31.51	100	115	Peak
2483.5	53.56	-0.44	54	49.9	33.01	2.16	31.51	100	115	Average
2483.5	42.56	-31.44	74	-	-	-	-	-	-	Peak
2483.5	41.72	-12.28	54	-	-	-	-	-	-	Average

Summary results of marker-delta method:

Test mode	Maximum field strength of the fundamental emission (dBµV/m)	Delta Result (dB)	Measurement Result (dBµV/m)	Limit (dBµV/m)	Margin (dB)	Result
Peak	95.6	53.04	42.56	74	-31.44	Pass
Average	94.76	53.04	41.72	54	-12.28	Pass

Note : Measurement result = Maximum field strength – Delta result



Test Mode :	Mode 3	Temperature :	23~24°C
Test Channel :	39	Relative Humidity :	43~44%
Test Engineer :	Stone Gu	Polarization :	Horizontal

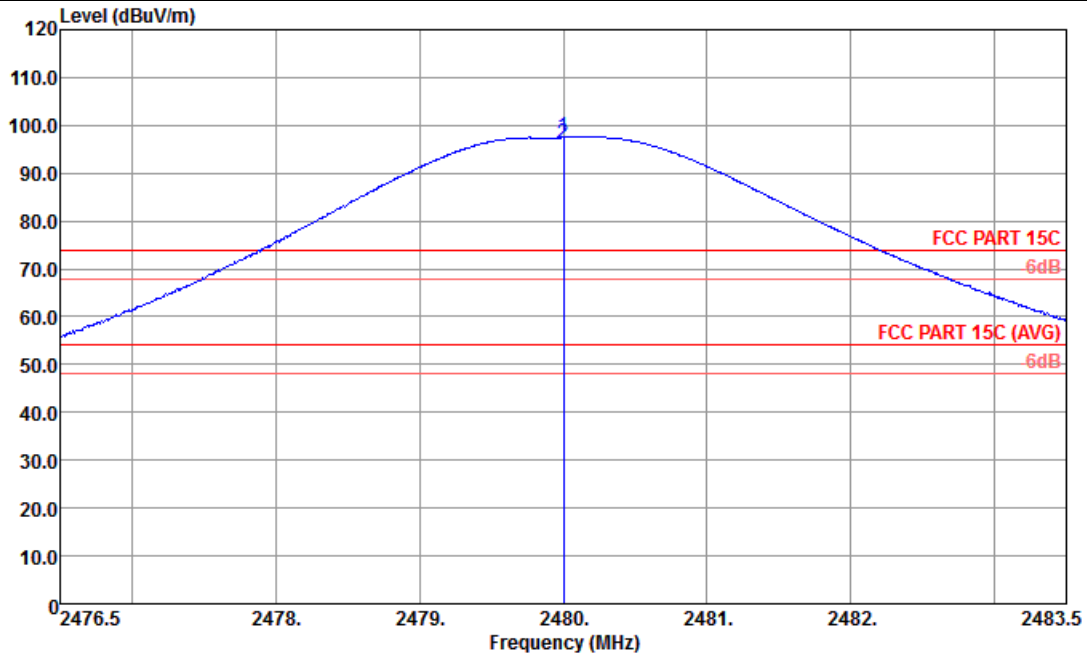

Site : 03CH01-KS
 Condition : FCC PART 15C 3m HF ANT-100803 HORIZONTAL
 : RBW:1000.000KHz VBW:3000.000KHz SWT:Auto

	Freq	Level	Over Limit	Limit Line	ReadAntenna Level	Antenna Factor	Cable Loss	Preamp Factor	A/Pos	T/Pos	Remark
	MHz	dBuV/m	dB	dBuV/m	dBuV	dB/m	dB	dB	cm	deg	
1 *	2480.00	97.55	23.55	74.00	93.89	33.01	2.16	31.51	106	45	Peak
2 *	2480.00	96.22	42.22	54.00	92.56	33.01	2.16	31.51	106	45	Average

* Maximum field strength of the fundamental emission



Test Mode :	Mode 3	Temperature :	23~24°C
Test Channel :	39	Relative Humidity :	43~44%
Test Engineer :	Stone Gu	Polarization :	Horizontal

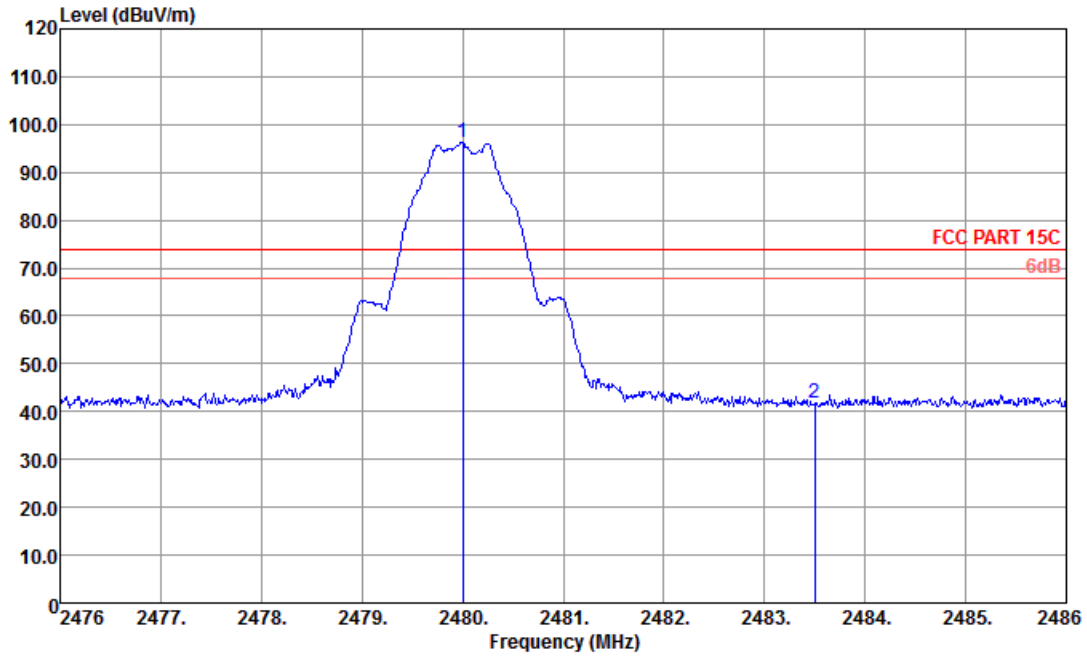

Site : 03CH01-KS
 Condition : FCC PART 15C 3m HF ANT-100803 HORIZONTAL
 : RBW:100.000KHz VBW:100.000KHz SWT:Auto

	Freq	Level	Over Limit	Limit Line	ReadAntenna Level	Antenna Factor	Cable Loss	Preamp Factor	A/Pos	T/Pos	Remark
	MHz	dBuV/m	dB	dBuV/m	dBuV	dB/m	dB	dB	cm	deg	
1 *	2480.00	96.30	22.30	74.00	92.64	33.01	2.16	31.51	107	46	Peak
2	2483.50	41.71	-32.29	74.00	38.05	33.01	2.16	31.51	107	46	Peak

* Marker-Delta Method (RBW/VBW=100kHz): 54.59 dB , single carrier Mode



Test Mode :	Mode 3	Temperature :	23~24°C
Test Channel :	39	Relative Humidity :	43~44%
Test Engineer :	Stone Gu	Polarization :	Vertical

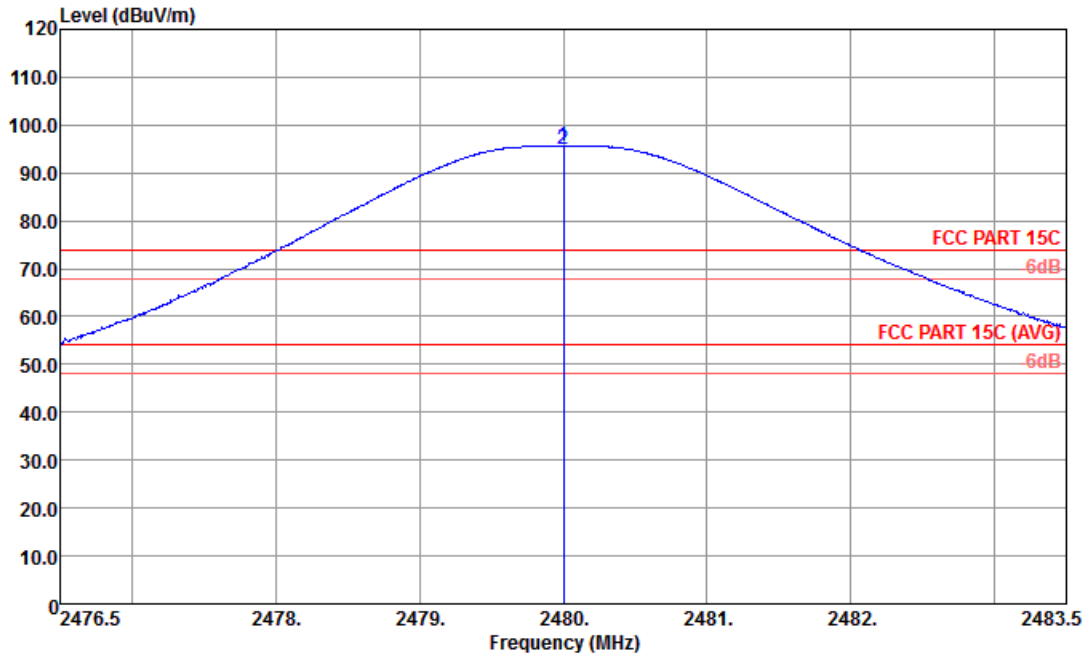

Site : 03CH01-KS
 Condition : FCC PART 15C 3m HF ANT-100803 VERTICAL
 : RBW:1000.000KHz VBW:3000.000KHz SWT:Auto

	Freq	Level	Over Limit	Limit Line	ReadAntenna Level	Antenna Factor	Cable Loss	Preamp Factor	A/Pos	I/Pos	Remark
	MHz	dBuV/m	dB	dBuV/m	dBuV	dB/m	dB	dB	cm	deg	
1 *	2480.00	95.60	21.60	74.00	91.94	33.01	2.16	31.51	100	101	Peak
2 *	2480.00	94.76	40.76	54.00	91.10	33.01	2.16	31.51	100	101	Average

* Maximum field strength of the fundamental emission



Test Mode :	Mode 3	Temperature :	23~24°C
Test Channel :	39	Relative Humidity :	43~44%
Test Engineer :	Stone Gu	Polarization :	Vertical

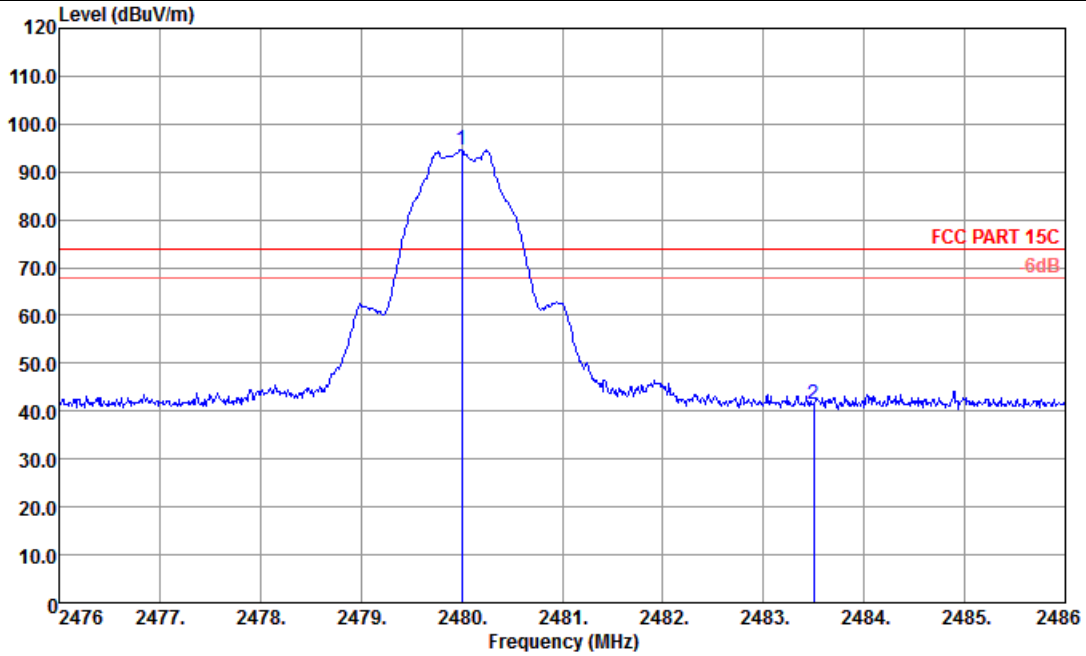

Site : 03CH01-KS
 Condition : FCC PART 15C 3m HF ANT-100803 VERTICAL
 : RBW:100.000KHz VBW:100.000KHz SWT:Auto

	Freq	Level	Over Limit	Limit Line	ReadAntenna Level	Antenna Factor	Cable Loss	Preamp Factor	A/Pos	I/Pos	Remark
	MHz	dBuV/m	dB	dBuV/m	dBuV	dB/m	dB	dB	cm	deg	
1 *	2480.00	94.60	20.60	74.00	90.94	33.01	2.16	31.51	100	122	Peak
2	2483.50	41.56	-32.44	74.00	37.90	33.01	2.16	31.51	100	122	Peak

* Marker-Delta Method (RBW/VBW=100kHz): 53.04 dB , single carrier Mode

3.5.7 Test Result of Radiated Spurious Emission (30 MHz ~ 10th Harmonic)

Note: Below 1GHz for radiated emission measurement, pre-scanned all test modes and only choose the worst case mode was recorded in the report.

Test Mode :	Mode 1	Temperature :	23~24°C
Test Channel :	00	Relative Humidity :	43~44%
Test Engineer :	Stone Gu	Polarization :	Horizontal
Remark :	1. 2402 MHz is fundamental signal which can be ignored. 2. 2399 MHz and 7206 MHz are not within restricted bands, and its limit lines are 20dB below the highest emission level. For example, 94.28 dBuV/m - 20dB = 74.28 dBuV/m. 3. Average measurement was not performed if peak level went lower than the average limit.		

Frequency (MHz)	Level (dBuV/m)	Over Limit (dB)	Limit Line (dBuV/m)	Read Level (dBuV)	Antenna Factor (dB)	Cable Loss (dB)	Preamp Factor (dB)	Ant Pos (cm)	Table Pos (deg)	Remark
2399	61.52	-12.76	74.28	58.06	32.86	2.11	31.51	167	75	Peak
2402	94.28	-	-	90.82	32.86	2.11	31.51	109	309	Peak
2402	93.51	-	-	90.05	32.86	2.11	31.51	109	309	Average
4804	48.69	-25.31	74	41.98	35.17	3.08	31.54	125	23	Peak
7206	50.61	-23.67	74.28	42.17	36.16	3.24	30.96	100	321	Peak



Test Mode :	Mode 1	Temperature :	23~24°C
Test Channel :	00	Relative Humidity :	43~44%
Test Engineer :	Stone Gu	Polarization :	Vertical
Remark :	1. 2402 MHz is fundamental signal which can be ignored. 2. 2399 MHz and 7206 MHz are not within restricted bands, and its limit lines are 20dB below the highest emission level. 3. Average measurement was not performed if peak level went lower than the average limit.		

Frequency (MHz)	Level (dBuV/m)	Over Limit (dB)	Limit Line (dBuV/m)	Read Level (dBuV)	Antenna Factor (dB)	Cable Loss (dB)	Preamp Factor (dB)	Ant Pos (cm)	Table Pos (deg)	Remark
2399	61.77	-16.27	78.04	58.31	32.86	2.11	31.51	101	143	Peak
2402	98.04	-	-	94.58	32.86	2.11	31.51	100	125	Peak
2402	97.19	-	-	93.73	32.86	2.11	31.51	100	125	Average
4804	49.38	-24.62	74	42.67	35.17	3.08	31.54	100	230	Peak
7206	50.21	-27.83	78.04	41.77	36.16	3.24	30.96	100	231	Peak



Test Mode :	Mode 2	Temperature :	23~24°C
Test Channel :	19	Relative Humidity :	43~44%
Test Engineer :	Stone Gu	Polarization :	Horizontal
Remark :	1. 2440 MHz is fundamental signal which can be ignored. 2. Average measurement was not performed if peak level went lower than the average limit.		

Frequency (MHz)	Level (dBuV/m)	Over Limit (dB)	Limit Line (dBuV/m)	Read Level (dBuV)	Antenna Factor (dB)	Cable Loss (dB)	Preamp Factor (dB)	Ant Pos (cm)	Table Pos (deg)	Remark
2440	96.96	-	-	93.38	32.95	2.14	31.51	111	76	Peak
2440	96.18	-	-	92.6	32.95	2.14	31.51	111	76	Average
4880	49.69	-24.31	74	42.91	35.18	3.12	31.52	100	0	Peak
7320	50.04	-23.96	74	41.56	36.21	3.21	30.94	121	68	Peak

Test Mode :	Mode 2	Temperature :	23~24°C
Test Channel :	19	Relative Humidity :	43~44%
Test Engineer :	Stone Gu	Polarization :	Vertical
Remark :	1. 2440 MHz is fundamental signal which can be ignored. 2. Average measurement was not performed if peak level went lower than the average limit.		

Frequency (MHz)	Level (dBuV/m)	Over Limit (dB)	Limit Line (dBuV/m)	Read Level (dBuV)	Antenna Factor (dB)	Cable Loss (dB)	Preamp Factor (dB)	Ant Pos (cm)	Table Pos (deg)	Remark
2440	97.83	-	-	94.25	32.95	2.14	31.51	125	105	Peak
2440	96.9	-	-	93.32	32.95	2.14	31.51	125	105	Average
4880	47.58	-26.42	74	40.8	35.18	3.12	31.52	215	45	Peak
7320	49.23	-24.77	74	40.75	36.21	3.21	30.94	121	68	Peak



Test Mode :	Mode 3	Temperature :	23~24°C
Test Channel :	39	Relative Humidity :	43~44%
Test Engineer :	Stone Gu	Polarization :	Horizontal
Remark :	1. 2480 MHz is fundamental signal which can be ignored. 2. Average measurement was not performed if peak level went lower than the average limit.		

Frequency (MHz)	Level (dBuV/m)	Over Limit (dB)	Limit Line (dBuV/m)	Read Level (dBuV)	Antenna Factor (dB)	Cable Loss (dB)	Preamp Factor (dB)	Ant Pos (cm)	Table Pos (deg)	Remark
98.87	32.58	-10.92	43.5	55.29	10.33	0.58	33.62	100	320	Peak
182.29	28.72	-14.78	43.5	53.08	8.42	0.79	33.57	-	-	Peak
265.71	26.14	-19.86	46	46.35	12.27	0.94	33.42	-	-	Peak
556.71	19.18	-26.82	46	32.34	18.51	1.34	33.01	-	-	Peak
835.1	34.16	-11.84	46	44.89	20.35	1.63	32.71	-	-	Peak
941.8	32.55	-13.45	46	42.54	20.7	1.75	32.44	-	-	Peak
2480	97.38	-	-	93.72	33.01	2.16	31.51	106	47	Peak
2480	96.53	-	-	92.87	33.01	2.16	31.51	106	47	Average
4960	47.63	-26.37	74	40.78	35.2	3.16	31.51	100	237	Peak
7440	50.5	-23.5	74	41.97	36.27	3.18	30.92	154	89	Peak



Test Mode :	Mode 3	Temperature :	23~24°C
Test Channel :	39	Relative Humidity :	43~44%
Test Engineer :	Stone Gu	Polarization :	Vertical
Remark :	1. 2480 MHz is fundamental signal which can be ignored. 2. Average measurement was not performed if peak level went lower than the average limit.		

Frequency (MHz)	Level (dBuV/m)	Over Limit (dB)	Limit Line (dBuV/m)	Read Level (dBuV)	Antenna Factor (dB)	Cable Loss (dB)	Preamp Factor (dB)	Ant Pos (cm)	Table Pos (deg)	Remark
43.58	26.18	-13.82	40	49.36	10.03	0.41	33.62	-	-	Peak
96.93	31.06	-12.44	43.5	54.08	10.03	0.57	33.62	-	-	Peak
128.94	22.4	-21.1	43.5	43.61	11.71	0.67	33.59	-	-	Peak
170.65	20.98	-22.52	43.5	44.65	9.14	0.76	33.57	-	-	Peak
835.1	36.31	-9.69	46	47.04	20.35	1.63	32.71	125	49	Peak
941.8	33.42	-12.58	46	43.41	20.7	1.75	32.44	-	-	Peak
2480	96.78	-	-	93.12	33.01	2.16	31.51	100	104	Peak
2480	95.98	-	-	92.32	33.01	2.16	31.51	100	104	Average
4960	47.83	-26.17	74	40.98	35.2	3.16	31.51	100	326	Peak
7440	49.69	-24.31	74	41.16	36.27	3.18	30.92	100	234	Peak

3.6 AC Conducted Emission Measurement

3.6.1 Limit of AC Conducted Emission

For equipment that is designed to be connected to the public utility (AC) power line, the radio frequency voltage that is conducted back onto the AC power line on any frequency or frequencies within the band 150 kHz to 30 MHz shall not exceed the limits in the following table.

Frequency of emission (MHz)	Conducted limit (dBuV)	
	Quasi-peak	Average
0.15-0.5	66 to 56*	56 to 46*
0.5-5	56	46
5-30	60	50

*Decreases with the logarithm of the frequency.

3.6.2 Measuring Instruments

See list of measuring instruments of this test report.

3.6.3 Test Procedures

1. The testing follows the guidelines in ANSI C63.10-2009 and ANSI C63.4-2003 test site requirement.
2. The EUT was placed 0.4 meter from the conducting wall of the shielding room was kept at least 80 centimeters from any other grounded conducting surface.
3. Connect EUT to the power mains through a line impedance stabilization network (LISN).
4. All the support units are connecting to the other LISN.
5. The LISN provides 50 ohm coupling impedance for the measuring instrument.
6. The FCC states that a 50 ohm, 50 microhenry LISN should be used.
7. Both sides of AC line were checked for maximum conducted interference.
8. The frequency range from 150 kHz to 30 MHz was searched.
9. Set the test-receiver system to Peak Detect Function and specified bandwidth with Maximum Hold Mode.

3.6.4 Test Setup

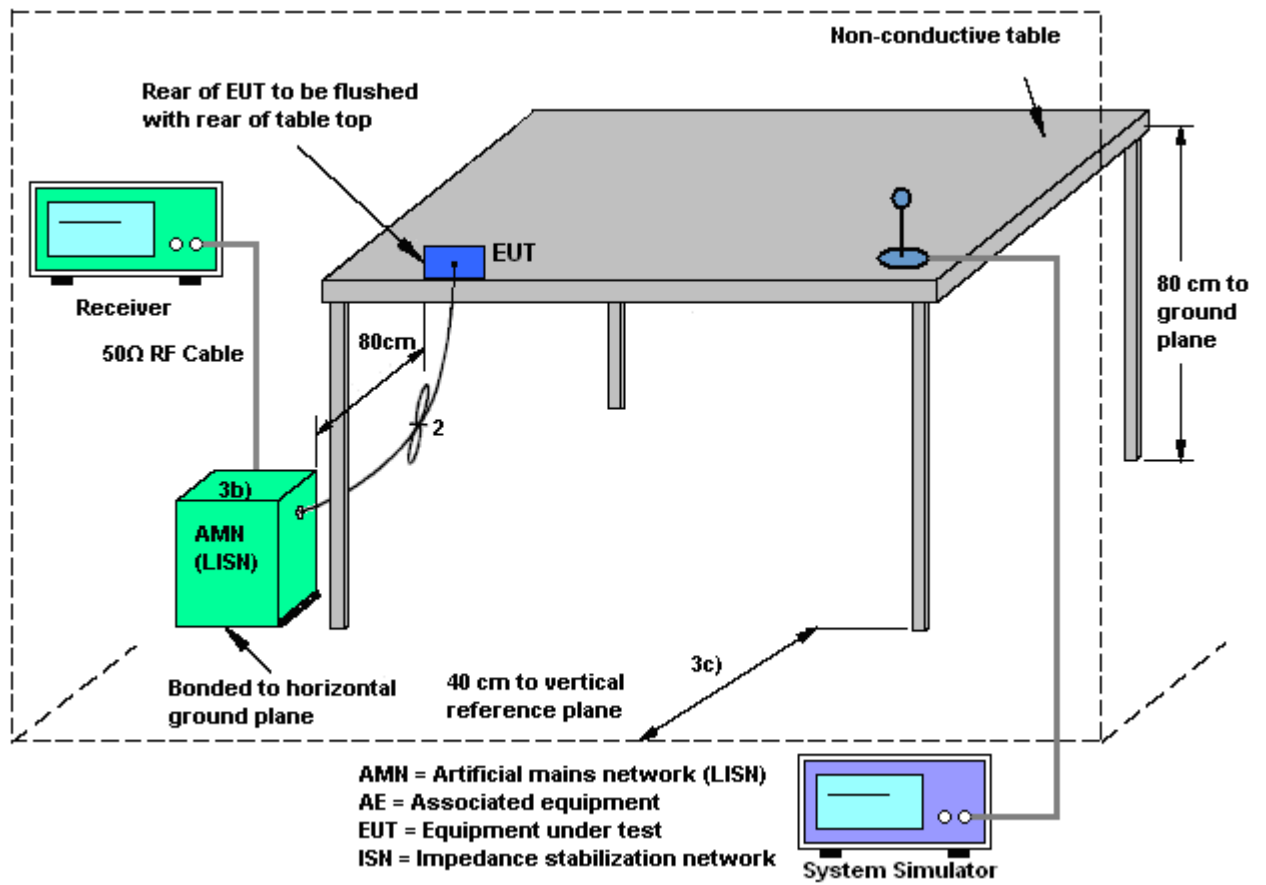



3.6.5 Test Result of AC Conducted Emission

Test Mode :	Mode 1	Temperature :	24~25°C
Test Engineer :	Leo Liao	Relative Humidity :	50~51%
Test Voltage :	120Vac / 60Hz	Phase :	Line
Function Type :	GSM850 Idle + Bluetooth Link + WLAN Link + USB Cable (Charging from Adapter) + Earphone		
Remark :	All emissions not reported here are more than 10 dB below the prescribed limit.		

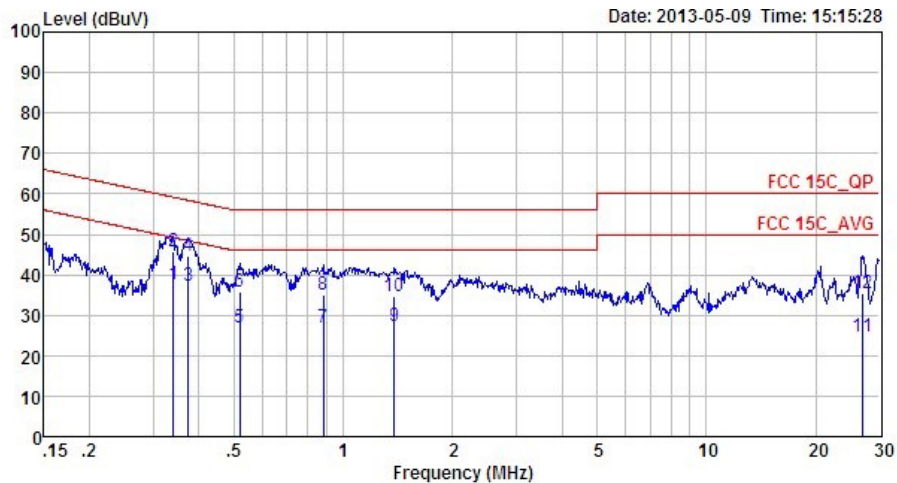

Site : CO01-SZ
 Condition: FCC 15C_QP LISN_L_2000601 LINE

	Freq	Level	Over	Limit	Read	LISN	Cable	
	MHz	dBuV	Limit	Line	Level	Factor	Loss	Remark
			dB	dBuV	dBuV	dB	dB	
1	0.34	37.69	-11.49	49.18	27.60	0.02	10.07	Average
2	0.34	45.79	-13.39	59.18	35.70	0.02	10.07	QP
3 *	0.38	37.30	-11.09	48.39	27.21	0.02	10.07	Average
4	0.38	44.70	-13.69	58.39	34.61	0.02	10.07	QP
5	0.52	27.11	-18.89	46.00	17.00	0.02	10.09	Average
6	0.52	35.91	-20.09	56.00	25.80	0.02	10.09	QP
7	0.88	26.93	-19.07	46.00	16.80	0.02	10.11	Average
8	0.88	35.03	-20.97	56.00	24.90	0.02	10.11	QP
9	1.38	27.35	-18.65	46.00	17.20	0.03	10.12	Average
10	1.38	34.85	-21.15	56.00	24.70	0.03	10.12	QP
11	26.98	24.90	-25.10	50.00	13.90	0.57	10.43	Average
12	26.98	35.60	-24.40	60.00	24.60	0.57	10.43	QP



Test Mode :	Mode 1	Temperature :	24~25°C
Test Engineer :	Leo Liao	Relative Humidity :	50~51%
Test Voltage :	120Vac / 60Hz	Phase :	Neutral
Function Type :	GSM850 Idle + Bluetooth Link + WLAN Link + USB Cable (Charging from Adapter) + Earphone		
Remark :	All emissions not reported here are more than 10 dB below the prescribed limit.		

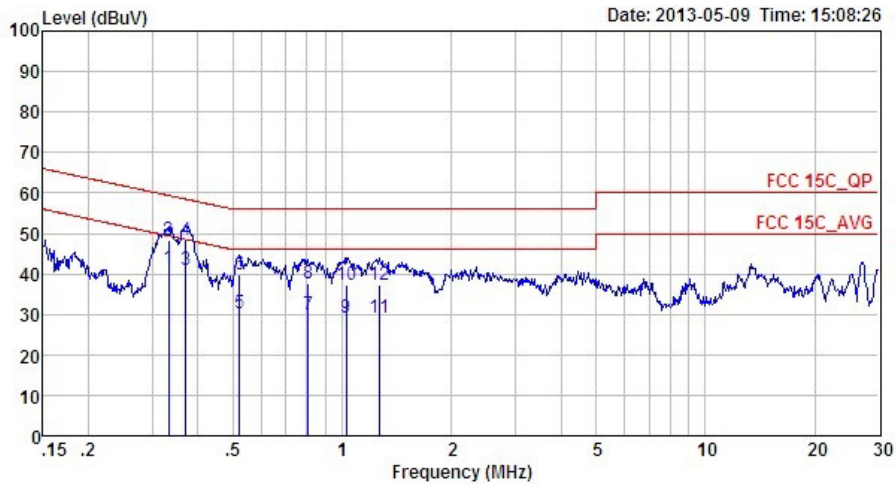

Site : CO01-SZ
 Condition: FCC 15C_QP LISN_N_2000601 NEUTRAL

	Freq	Level	Over	Limit	Read	LISN	Cable	
	MHz	dBuV	Limit	Line	Level	Factor	Loss	Remark
			dB	dBuV	dBuV	dB	dB	
1	0.33	41.38	-8.02	49.40	31.29	0.02	10.07	Average
2	0.33	48.28	-11.12	59.40	38.19	0.02	10.07	QP
3 *	0.37	40.89	-7.58	48.47	30.80	0.02	10.07	Average
4	0.37	48.39	-10.08	58.47	38.30	0.02	10.07	QP
5	0.52	30.30	-15.70	46.00	20.19	0.02	10.09	Average
6	0.52	39.70	-16.30	56.00	29.59	0.02	10.09	QP
7	0.80	29.93	-16.07	46.00	19.80	0.02	10.11	Average
8	0.80	37.73	-18.27	56.00	27.60	0.02	10.11	QP
9	1.03	29.14	-16.86	46.00	19.01	0.02	10.11	Average
10	1.03	37.44	-18.56	56.00	27.31	0.02	10.11	QP
11	1.26	29.05	-16.95	46.00	18.91	0.02	10.12	Average
12	1.26	37.35	-18.65	56.00	27.21	0.02	10.12	QP



3.7 Antenna Requirements

3.7.1 Standard Applicable

If directional gain of transmitting antennas is greater than 6dBi, the power shall be reduced by the same level in dB comparing to gain minus 6dBi. The use of a permanently attached antenna or of an antenna that uses a unique coupling to the intentional radiator shall be considered sufficient to comply with the FCC rule.

3.7.2 Antenna Connected Construction

Non-standard connector used.

3.7.3 Antenna Gain

The antenna peak gain of EUT is less than 6 dBi. Therefore, it is not necessary to reduce maximum peak output power limit.



4 List of Measuring Equipment

Instrument	Manufacturer	Model No.	Serial No.	Characteristics	Calibration Date	Test Date	Due Date	Remark
Spectrum Analyzer	R&S	FSP30	101400	9kHz~30GHz	Jun. 01, 2012	May 05, 2013	May 31, 2013	Conducted (TH01-SZ)
Power meter	Anritsu	ML2495A	1218010	N/A	Mar. 28, 2013	May 05, 2013	Mar. 27, 2014	Conducted (TH01-SZ)
Power Senso	Anritsu	MA2411B	1207253	N/A	Mar. 28, 2013	May 05, 2013	Mar. 27, 2014	Conducted (TH01-SZ)
EMI Test Receiver	R&S	ESCI	100534	9kHz~3GHz	Nov. 08, 2012	May 09, 2013	Nov. 07, 2013	Radiation (03CH01-KS)
Spectrum Analyzer	R&S	FSP30	100400	9kHz~30GHz	Jun. 01, 2012	May 09, 2013	May 31, 2013	Radiation (03CH01-KS)
Bilog Antenna	SCHAFFNER	CBL6112D	23182	25MHz~2GHz	Dec. 07, 2012	May 09, 2013	Dec. 06, 2013	Radiation (03CH01-KS)
HFH2-Z2 Loop Antenna	R&S	HFH2-Z2	100321	9kHz-30MHz	Oct. 22, 2012	May 09, 2013	Oct. 21, 2013	Radiation (03CH01-KS)
Double Ridge Horn Antenna	ETS-Lindgren	1908/7/13	00075957	1GHz~18GHz	Dec. 07, 2012	May 09, 2013	Dec. 06, 2013	Radiation (03CH01-KS)
Amplifier	com-power	PA-103A	161069	1MHz~1GHz	Jun. 01, 2012	May 09, 2013	May 31, 2013	Radiation (03CH01-KS)
Amplifier	Agilent	8449B	3008A02370	1GHz~26.5GHz	Dec. 29, 2012	May 09, 2013	Dec. 28, 2013	Radiation (03CH01-KS)
Active Horn Antenna	com-power	AHA-118	701023	1GHz~18GHz	Nov. 07, 2012	May 09, 2013	Nov. 06, 2013	Radiation (03CH01-KS)
SHF-EHF Horn	Schwarzbeck	BBHA 9170	9170249	15GHz~40GHz	Nov. 23, 2012	May 09, 2013	Nov. 22, 2013	Radiation (03CH01-KS)
ESCIO TEST Receiver	R&S	1142.8007.03	100724	9kHz -3GHz	Mar. 28, 2013	May 09, 2013	Mar. 27, 2014	Conduction (CO01-SZ)
AC LISN	ETS-LINDGREN	3816/2SH	00103912	9kHz~30MHz	Mar. 28, 2013	May 09, 2013	Mar. 27, 2014	Conduction (CO01-SZ)
AC LISN	ETS-LINDGREN	3816/2SH	00103892	9kHz~30MHz	Mar. 28, 2013	May 09, 2013	Mar. 27, 2014	Conduction (CO01-SZ)
AC Source	Chroma	61602	616020000891	N/A	Nov.20, 2012	May 09, 2013	Nov. 19, 2013	Conduction (CO01-SZ)

5 Uncertainty of Evaluation

Uncertainty of Conducted Emission Measurement (150 kHz ~ 30 MHz)

Measuring Uncertainty for a Level of Confidence of 95% ($U = 2Uc(y)$)	2.26
---	------

Uncertainty of Radiated Emission Measurement (30 MHz ~ 1000 MHz)

Measuring Uncertainty for a Level of Confidence of 95% ($U = 2Uc(y)$)	2.54
---	------

Uncertainty of Radiated Emission Measurement (1 GHz ~ 40 GHz)

Measuring Uncertainty for a Level of Confidence of 95% ($U = 2Uc(y)$)	4.72
---	------



Appendix A. Photographs of EUT

Please refer to Sporton report number EP342511 as below.