



No. 1 Workshop, M-10, Middle section, Science & Technology Park,
Shenzhen, Guangdong, China 518057

Telephone: +86 (0) 755 2601 2053

Fax: +86 (0) 755 2671 0594

Email: sgs_internet_operations@sgs.com

Report No.: SZEMO08110562001

Page: 1 of 18

FCC REPORT

Application No.: SZEMO081105620RF
Applicant: Current Cost Ltd
Product Name: Energy Monitor
Operation Frequency : 433.92MHz
FCC ID: WW9-2008-CC128
Standards: FCC CFR Title 47 Part 15 Subpart C Section 15.231: 2008
Date of Receipt: 17 November 2008
Date of Test: 17 November 2008 to 17 March 2010
Date of Issue: 18 March 2010

Test Result :	PASS *
----------------------	---------------

* In the configuration tested, the EUT complied with the standards specified above.

Authorized Signature:

Robinson Lo
Laboratory Manager

The manufacturer should ensure that all products in series production are in conformity with the product sample detailed in this report. If the product in this report is used in any configuration other than that detailed in the report, the manufacturer must ensure the new system complies with all relevant standards. Any mention of SGS International Electrical Approvals or testing done by SGS International Electrical Approvals in connection with, distribution or use of the product described in this report must be approved by SGS International Electrical Approvals in writing.

The report must not be used by the client to claim product certification, approval, or endorsement by NVLAP, NIST, or any agency of the federal government. All test results in this report can be traceable to National or International Standards.

"This document is issued by the Company subject to its General Conditions of Service printed overleaf, available on request or accessible at www.sgs.com/terms_and_conditions.htm and, for electronic format documents, subject to Terms and Conditions for Electronic Documents at www.sgs.com/terms_e-document.htm. Attention is drawn to the limitation of liability, indemnification and jurisdiction issues defined therein. Any holder of this document is advised that information contained hereon reflects the Company's findings at the time of its intervention only and within the limits of Client's instructions, if any. The Company's sole responsibility is to its Client and this document does not exonerate parties to a transaction from exercising all their rights and obligations under the transaction documents. This document cannot be reproduced except in full, without prior written approval of the Company. Any unauthorized alteration, forgery or falsification of the content or appearance of this document is unlawful and offenders may be prosecuted to the fullest extent of the law. Unless otherwise stated the results shown in this test report refer only to the sample(s) tested and such sample(s) are retained for 90 days only."



2 Contents

	Page
.....	1
2 CONTENTS	2
3 TEST SUMMARY	3
4 GENERAL INFORMATION.....	4
4.1 CLIENT INFORMATION	4
4.2 GENERAL DESCRIPTION OF E.U.T.....	4
4.3 E.U.T ENVIRONMENTS AND TEST MODES	5
4.4 TEST FACILITY	6
4.5 TEST LOCATION	6
4.6 OTHER INFORMATION REQUESTED BY THE CUSTOMER.....	6
4.7 TEST INSTRUMENTS LIST	7
5 TEST RESULTS AND MEASUREMENT DATA.....	8
5.1 ANTENNA REQUIREMENT:	8
5.2 RADIATED EMISSION.....	9
5.2.1 <i>Field Strength Of The Fundamental Signal</i>	11
5.2.2 <i>Spurious Emissions</i>	13
5.3 20DB BANDWIDTH	15
5.4 TRANSMIT TIME AND SILENT PERIOD:.....	17-18



3 Test Summary

Test Item	Section in CFR 47	Result
Antenna requirement	15.203	Passed
Field strength of the fundamental signal	15.231 (e)	Passed
Spurious emissions	15.231 (b)/15.209	Passed
20dB Bandwidth	15.231 (c)	Passed
Transmit Time and Silent Period	15.231 (e)	Passed

Remark: Passed: The EUT complies with the essential requirements in the standard.

Failed: The EUT does not comply with the essential requirements in the standard.



4 General Information

4.1 Client Information

Applicant:	Current Cost Ltd
Address of Applicant:	1.The Mews Wharf Street Godalming Surrey united Kingdom GU7 INN
Manufacturer/ Factory:	Dong Guan Richtek Electric-Mechanical Co., Ltd.
Address of Manufacturer/ Factory:	NO. 11. KuiQing Road, Qing Xi Town, DongGuan City, China

4.2 General Description of E.U.T.

Product Name:	Energy Monitor
Trade Name:	N/A
Item No.:	CC128
Operation Frequency:	433.92MHz
Modulation type:	FSK
Antenna Type:	Integral
Power supply:	DC Voltage: 2*1.5V (LR20 size "D") = 3.0V



4.3 E.U.T Environments and test modes

Operating Environment:	
Temperature:	24.0 °C
Humidity:	52 % RH
Atmospheric Pressure:	1008 mbar
Test mode:	
Transmitting mode	Keep the sensor unit transmit mode.
On mode	Keep the sensor unit and display unit communicate mode.



4.4 Test Facility

The test facility is recognized, certified, or accredited by the following organizations:

CNAS (No. CNAS L2929)

CNAS has accredited SGS-CSTC Standards Technical Services Co., Ltd. Shenzhen Branch EMC Lab to ISO/IEC 17025:2005 General Requirements for the Competence of Testing and Calibration Laboratories (CNAS-CL01 Accreditation Criteria for the Competence of Testing and Calibration Laboratories) for the competence in the field of testing.

VCCI

The 3m Semi-anechoic chamber and Shielded Room (7.5m x 4.0m x 3.0m) of SGS-CSTC Standards Technical Services Co., Ltd. have been registered in accordance with the Regulations for Voluntary Control Measures with Registration No.: R-2197 and C-2383 respectively.

Date of Registration: September 29, 2008. Valid until September 28, 2011.

FCC – Registration No.: 556682

SGS-CSTC Standards Technical Services Co., Ltd., Shenzhen EMC Laboratory has been registered and fully described in a report filed with the (FCC) Federal Communications Commission. The acceptance letter from the FCC is maintained in our files. Registration 556682, June 27, 2008.

Industry Canada (IC)

The 3m Semi-anechoic chamber of SGS-CSTC Standards Technical Services Co., Ltd. has been registered by Certification and Engineering Bureau of Industry Canada for radio equipment testing with Registration No.: 4620C-1.

4.5 Test Location

All tests were performed at:

SGS-CSTC Standards Technical Services Co., Ltd. Shenzhen Branch E&E Lab

No. 1 Workshop, M-10, Middle section, Science & Technology Park, Shenzhen, Guangdong, China
518057

Telephone: +86 (0) 755 2601 2053 Fax: +86 (0) 755 2671 0594

No tests were sub-contracted.

4.6 Other Information Requested by the Customer

None.



4.7 Test Instruments list

RE in Chamber						
Item	Test Equipment	Manufacturer	Model No.	Inventory No.	Cal.Date (dd-mm-yy)	Cal.Due date (dd-mm-yy)
1	3m Semi-Anechoic Chamber	ETS-LINDGREN	N/A	SEL0017	16-06-2009	15-06-2010
2	EMI Test Receiver	Rohde & Schwarz	ESIB26	SEL0023	12-12-2009	11-12-2010
3	EMI Test software	AUDIX	E3	SEL0050	N/A	N/A
4	Coaxial cable	SGS	N/A	SEL0028	18-06-2009	17-06-2010
5	BiConiLog Antenna (26-3000MHz)	ETS-LINDGREN	3142C	SEL0014	12-08-2009	11-08-2010
6	Double-ridged horn (1-18GHz)	ETS-LINDGREN	3117	SEL0005	12-08-2009	11-08-2010
8	Pre-amplifier (0.1-1300MHz)	Agilent Technologies	8447D	SEL0053	18-06-2009	17-06-2010
9	Pre-amplifier (1-18GHz)	Rohde & Schwarz	AFS42-00101 800-25-S-42	SEL0081	18-06-2009	17-06-2010

RF conducted						
Item	Test Equipment	Manufacturer	Model No.	Inventory No.	Cal.Date (dd-mm-yy)	Cal.Due date (dd-mm-yy)
1	Spectrum Analyzer	Rohde & Schwarz	10336/030	EMC0040	16-06-2009	15-06-2010
2	Coaxial cable	SGS	N/A	SEL0028	18-06-2009	17-06-2010

"This document is issued by the Company subject to its General Conditions of Service printed overleaf, available on request or accessible at www.sgs.com/terms_and_conditions.htm and, for electronic format documents, subject to Terms and Conditions for Electronic Documents at www.sgs.com/terms_e-document.htm. Attention is drawn to the limitation of liability, indemnification and jurisdiction issues defined therein. Any holder of this document is advised that information contained hereon reflects the Company's findings at the time of its intervention only and within the limits of Client's instructions, if any. The Company's sole responsibility is to its Client and this document does not exonerate parties to a transaction from exercising all their rights and obligations under the transaction documents. This document cannot be reproduced except in full, without prior written approval of the Company. Any unauthorized alteration, forgery or falsification of the content or appearance of this document is unlawful and offenders may be prosecuted to the fullest extent of the law. Unless otherwise stated the results shown in this test report refer only to the sample(s) tested and such sample(s) are retained for 90 days only."

5 Test results and Measurement Data

5.1 Antenna requirement:

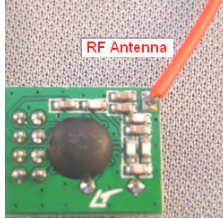
Standard requirement:	FCC Part15 C Section 15.203
<p>15.203 requirement: <i>An intentional radiator shall be designed to ensure that no antenna other than that furnished by the responsible party shall be used with the device. The use of a permanently attached antenna or of an antenna that uses a unique coupling to the intentional radiator, the manufacturer may design the unit so that a broken antenna can be replaced by the user, but the use of a standard antenna jack or electrical connector is prohibited.</i></p>	
E.U.T Antenna:	



5.2 Radiated Emission

Test Requirement:	FCC Part15 C Section 15.231(e) and 15.209																						
Test Method:	ANSI C63.4: 2003																						
Test Frequency Range:	30MHz to 5000MHz																						
Test site:	Measurement Distance: 3m (Semi-Anechoic Chamber)																						
Receiver setup:	<table border="1"> <thead> <tr> <th>Frequency</th> <th>Detector</th> <th>RBW</th> <th>VBW</th> </tr> </thead> <tbody> <tr> <td>30MHz-1GHz</td> <td>Quasi-peak</td> <td>100KHz</td> <td>300KHz</td> </tr> <tr> <td>Above 1GHz</td> <td>Peak</td> <td>1MHz</td> <td>3MHz</td> </tr> </tbody> </table>			Frequency	Detector	RBW	VBW	30MHz-1GHz	Quasi-peak	100KHz	300KHz	Above 1GHz	Peak	1MHz	3MHz								
Frequency	Detector	RBW	VBW																				
30MHz-1GHz	Quasi-peak	100KHz	300KHz																				
Above 1GHz	Peak	1MHz	3MHz																				
Limit: (Field strength of the fundamental signal)	<table border="1"> <thead> <tr> <th>Frequency</th> <th>Limit (dBuV/m @3m)</th> <th>Remark</th> </tr> </thead> <tbody> <tr> <td rowspan="2">433.92MHz</td> <td>72.87</td> <td>Average Value</td> </tr> <tr> <td>92.87</td> <td>Peak Value</td> </tr> </tbody> </table>			Frequency	Limit (dBuV/m @3m)	Remark	433.92MHz	72.87	Average Value	92.87	Peak Value												
Frequency	Limit (dBuV/m @3m)	Remark																					
433.92MHz	72.87	Average Value																					
	92.87	Peak Value																					
Limit: (Spurious Emissions)	<table border="1"> <thead> <tr> <th>Frequency</th> <th>Limit (dBuV/m @3m)</th> <th>Remark</th> </tr> </thead> <tbody> <tr> <td>30MHz-88MHz</td> <td>40.0</td> <td>Quasi-peak Value</td> </tr> <tr> <td>88MHz-216MHz</td> <td>43.5</td> <td>Quasi-peak Value</td> </tr> <tr> <td>216MHz-960MHz</td> <td>46.0</td> <td>Quasi-peak Value</td> </tr> <tr> <td>960MHz-1GHz</td> <td>54.0</td> <td>Quasi-peak Value</td> </tr> <tr> <td rowspan="2">Above 1GHz</td> <td>54.0</td> <td>Average Value</td> </tr> <tr> <td>74.0</td> <td>Peak Value</td> </tr> </tbody> </table> <p>Or The maximum permitted unwanted emission level is 20 dB below the maximum permitted fundamental level Whichever limit permits a higher field strength.</p>			Frequency	Limit (dBuV/m @3m)	Remark	30MHz-88MHz	40.0	Quasi-peak Value	88MHz-216MHz	43.5	Quasi-peak Value	216MHz-960MHz	46.0	Quasi-peak Value	960MHz-1GHz	54.0	Quasi-peak Value	Above 1GHz	54.0	Average Value	74.0	Peak Value
Frequency	Limit (dBuV/m @3m)	Remark																					
30MHz-88MHz	40.0	Quasi-peak Value																					
88MHz-216MHz	43.5	Quasi-peak Value																					
216MHz-960MHz	46.0	Quasi-peak Value																					
960MHz-1GHz	54.0	Quasi-peak Value																					
Above 1GHz	54.0	Average Value																					
	74.0	Peak Value																					
Test Procedure:	<ol style="list-style-type: none"> 1. The E.U.T and its simulators are placed on a turn table which is 0.8meter above ground. The turn table can rotate 360 degrees to determine the position of the maximum emission level. The antenna can move up and down between 1 meter and 4 meters to find out the maximum emission level. 2. Both horizontal and vertical polarization of the antenna is set on measurement. In order to find the maximum emission, all of the interface cables must be manipulated according to ANSI C63.4:2003 on radiated measurement. 3. Pre-scan the EUT is placed on X axis, Y axis, Z axis, and found the X axis which it is worse case. 																						
Test Instruments:	Refer to section 4.7 for details																						
Test mode:	Transmitting mode																						
Test results:	Passed																						

"This document is issued by the Company subject to its General Conditions of Service printed overleaf, available on request or accessible at www.sgs.com/terms_and_conditions.htm and, for electronic format documents, subject to Terms and Conditions for Electronic Documents at www.sgs.com/terms_e-document.htm. Attention is drawn to the limitation of liability, indemnification and jurisdiction issues defined therein. Any holder of this document is advised that information contained hereon reflects the Company's findings at the time of its intervention only and within the limits of Client's instructions, if any. The Company's sole responsibility is to its Client and this document does not exonerate parties to a transaction from exercising all their rights and obligations under the transaction documents. This document cannot be reproduced except in full, without prior written approval of the Company. Any unauthorized alteration, forgery or falsification of the content or appearance of this document is unlawful and offenders may be prosecuted to the fullest extent of the law. Unless otherwise stated the results shown in this test report refer only to the sample(s) tested and such sample(s) are retained for 90 days only."

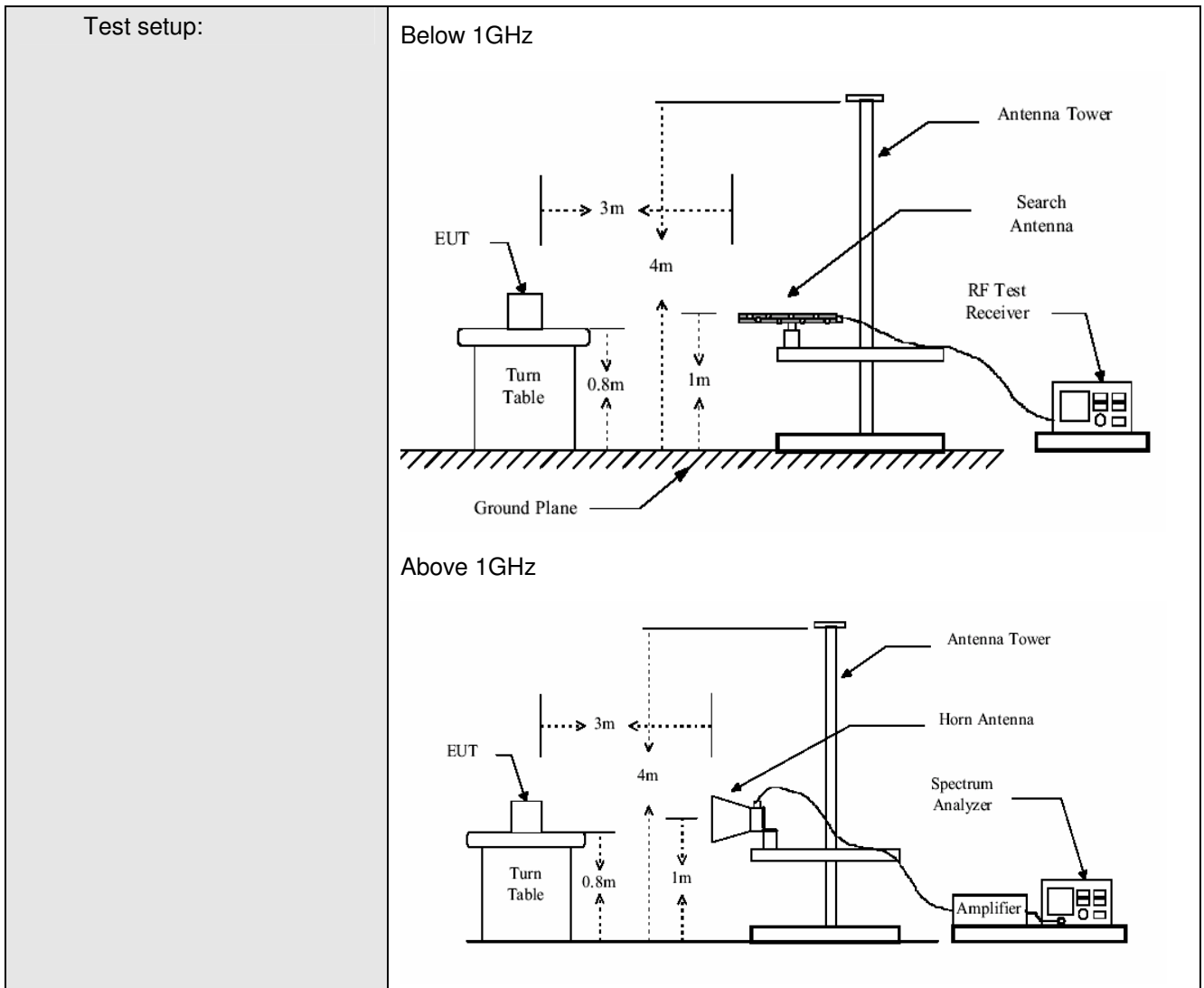

Note:

The field strength is calculated by adding the Antenna Factor, Cable Factor & Preamplifier. The basic equation with a sample calculation is as follows:

$$\text{Final Test Level} = \text{Receiver Reading} + \text{Antenna Factor} + \text{Cable Factor} - \text{Preamplifier Factor}$$



Measurement Data

5.2.1 Field Strength Of The Fundamental Signal

Peak value:								
Frequency (MHz)	Cable Loss (dB)	Antenna Factor (dB/m)	Preamp Factor (dB)	Read Level (dBuV)	Level (dBuV/m)	Limit Line (dBuV/m)	Over Limit (dB)	Polarization
433.92	2.35	16.62	27.38	72.51	64.10	92.87	-28.77	Horizontal
433.92	2.35	16.62	27.38	85.51	77.10	92.87	-15.77	Vertical

Average value:	
Calculate Formula:	Average value=Peak value + PDCF
	PDCF=20 log(Duty cycle)=20 log0.0714= -22.93
	Duty cycle= T on time / T period =0.42ms*17/100ms=0.0714

Test data:					
Frequency	Peak vauel	PDCF	Average Vauel	Limit (dBuV/m)	Polarization
433.92	64.10	-22.93	41.17	72.87	Horizontal
433.92	77.10	-22.93	54.17	72.87	Vertical

Test plot as follows:

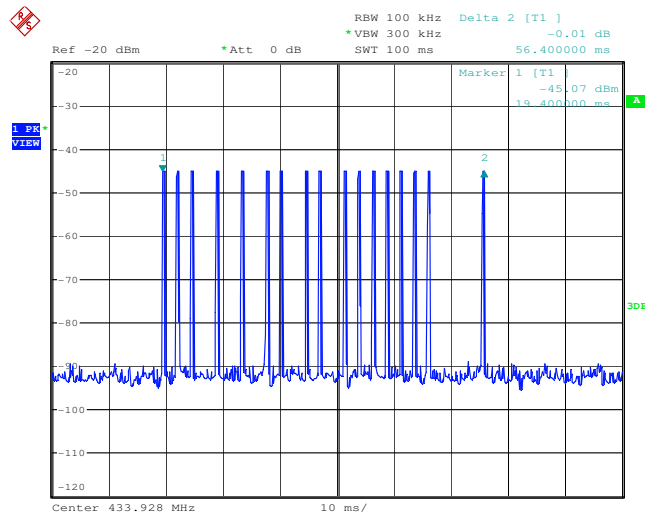

Date: 21.APR.2010 15:19:43

"This document is issued by the Company subject to its General Conditions of Service printed overleaf, available on request or accessible at www.sgs.com/terms_and_conditions.htm and, for electronic format documents, subject to Terms and Conditions for Electronic Documents at www.sgs.com/terms_e-document.htm. Attention is drawn to the limitation of liability, indemnification and jurisdiction issues defined therein. Any holder of this document is advised that information contained hereon reflects the Company's findings at the time of its intervention only and within the limits of Client's instructions, if any. The Company's sole responsibility is to its Client and this document does not exonerate parties to a transaction from exercising all their rights and obligations under the transaction documents. This document cannot be reproduced except in full, without prior written approval of the Company. Any unauthorized alteration, forgery or falsification of the content or appearance of this document is unlawful and offenders may be prosecuted to the fullest extent of the law. Unless otherwise stated the results shown in this test report refer only to the sample(s) tested and such sample(s) are retained for 90 days only."

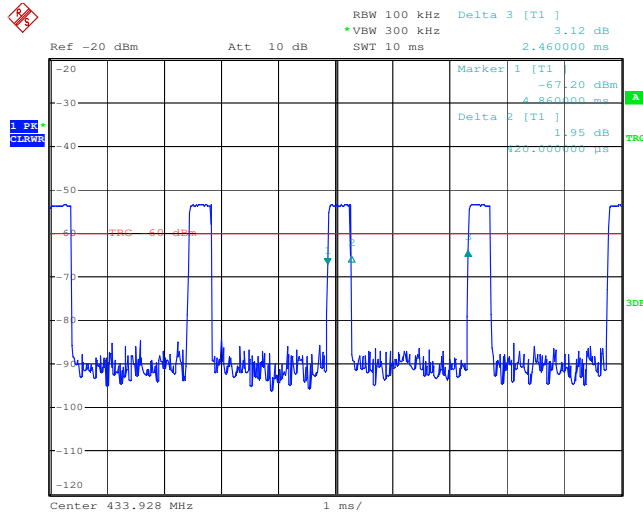

Date: 21.APR.2010 09:26:56

Remark:

Pre-scan transmit with all kind of current, and found the above plot which it is worse case.



5.2.2 Spurious Emissions

30MHz~1GHz

Frequency (MHz)	Cable Loss (dB)	Antenna Factor (dB/m)	Preamp Factor (dB)	Read Level (dBuV)	Level (dBuV/m)	Limit Line (dBuV/m)	Over Limit (dB)	Polarization
39.70	0.60	11.30	28.09	32.52	16.33	40.00	-23.67	Vertical
51.34	0.80	7.89	28.10	35.13	15.72	40.00	-24.28	Vertical
90.14	1.10	8.71	27.95	33.85	15.71	43.50	-27.79	Vertical
98.87	1.19	9.06	27.89	35.34	17.70	43.50	-25.80	Vertical
362.71	2.10	15.72	27.18	32.30	22.94	46.00	-23.06	Vertical
866.14	3.48	22.77	26.60	34.58	34.23	46.00	-11.77	Vertical
98.87	1.19	9.06	27.89	33.36	15.72	43.50	-27.78	Horizontal
331.67	2.00	14.98	26.96	36.97	26.99	46.00	-19.01	Horizontal
342.34	2.04	15.22	27.04	37.19	27.41	46.00	-18.59	Horizontal
362.71	2.10	15.72	27.18	37.09	27.73	46.00	-18.27	Horizontal
412.18	2.26	16.35	27.45	38.77	29.93	46.00	-16.07	Horizontal
475.23	2.51	17.80	27.64	35.20	27.87	46.00	-18.13	Horizontal

"This document is issued by the Company subject to its General Conditions of Service printed overleaf, available on request or accessible at www.sgs.com/terms_and_conditions.htm and, for electronic format documents, subject to Terms and Conditions for Electronic Documents at www.sgs.com/terms_e-document.htm. Attention is drawn to the limitation of liability, indemnification and jurisdiction issues defined therein. Any holder of this document is advised that information contained hereon reflects the Company's findings at the time of its intervention only and within the limits of Client's instructions, if any. The Company's sole responsibility is to its Client and this document does not exonerate parties to a transaction from exercising all their rights and obligations under the transaction documents. This document cannot be reproduced except in full, without prior written approval of the Company. Any unauthorized alteration, forgery or falsification of the content or appearance of this document is unlawful and offenders may be prosecuted to the fullest extent of the law. Unless otherwise stated the results shown in this test report refer only to the sample(s) tested and such sample(s) are retained for 90 days only."



Above 1GHz

Peak average:

Frequency (MHz)	Cable Loss (dB)	Antenna Factor (dB/m)	Preamp Factor (dB)	Read Level (dBuV)	Level (dBuV/m)	Limit Line (dBuV/m)	Over Limit (dB)	Polarization
1301.85	4.52	26.53	39.41	52.76	44.40	74.00	-29.60	Vertical
1735.80	5.24	28.01	38.73	53.94	48.46	74.00	-25.54	Vertical
2169.75	5.64	28.47	38.81	52.47	47.77	74.00	-26.23	Vertical
2603.70	6.12	29.51	38.94	53.71	50.40	74.00	-23.60	Vertical
3037.65	6.37	30.08	39.05	54.95	52.35	74.00	-21.65	Vertical
1301.85	4.52	26.53	39.41	52.67	44.31	74.00	-29.69	Horizontal
1735.80	5.24	28.01	38.73	53.05	47.57	74.00	-26.43	Horizontal
2169.75	5.64	28.47	38.81	51.84	47.14	74.00	-26.86	Horizontal
2603.70	6.12	29.51	38.94	53.64	50.33	74.00	-23.67	Horizontal
3037.65	6.37	30.08	39.05	52.71	50.11	74.00	-23.89	Horizontal

Average value:

Frequency (MHz)	Cable Loss (dB)	Antenna Factor (dB/m)	Preamp Factor (dB)	Read Level (dBuV)	Level (dBuV/m)	Limit Line (dBuV/m)	Over Limit (dB)	Polarization
1301.85	4.52	26.53	39.41	41.28	32.92	54.00	-21.08	Vertical
1735.80	5.24	28.01	38.73	39.47	33.99	54.00	-20.01	Vertical
2169.75	5.64	28.47	38.81	40.21	35.51	54.00	-18.49	Vertical
2603.70	6.12	29.51	38.94	41.63	38.32	54.00	-15.68	Vertical
3037.65	6.37	30.08	39.05	42.08	39.48	54.00	-14.52	Vertical
1301.85	4.52	26.53	39.41	40.54	32.18	54.00	-21.82	Horizontal
1735.80	5.24	28.01	38.73	40.67	35.19	54.00	-18.81	Horizontal
2169.75	5.64	28.47	38.81	39.58	34.88	54.00	-19.12	Horizontal
2603.70	6.12	29.51	38.94	41.34	38.03	54.00	-15.97	Horizontal
3037.65	6.37	30.08	39.05	42.53	39.93	54.00	-14.07	Horizontal

"This document is issued by the Company subject to its General Conditions of Service printed overleaf, available on request or accessible at www.sgs.com/terms_and_conditions.htm and, for electronic format documents, subject to Terms and Conditions for Electronic Documents at www.sgs.com/terms_e-document.htm. Attention is drawn to the limitation of liability, indemnification and jurisdiction issues defined therein. Any holder of this document is advised that information contained hereon reflects the Company's findings at the time of its intervention only and within the limits of Client's instructions, if any. The Company's sole responsibility is to its Client and this document does not exonerate parties to a transaction from exercising all their rights and obligations under the transaction documents. This document cannot be reproduced except in full, without prior written approval of the Company. Any unauthorized alteration, forgery or falsification of the content or appearance of this document is unlawful and offenders may be prosecuted to the fullest extent of the law. Unless otherwise stated the results shown in this test report refer only to the sample(s) tested and such sample(s) are retained for 90 days only."

5.3 20dB Bandwidth

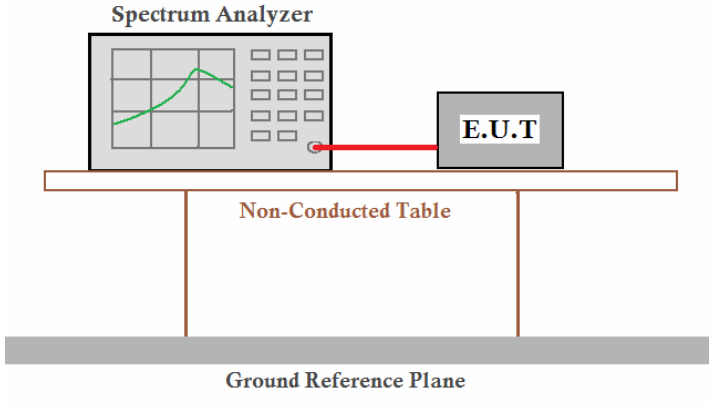
Test Requirement:	FCC Part15 C Section 15.231 (c)
Test Method:	ANSI C63.4:2003
Limit:	The bandwidth of the emission shall be no wider than 0.25% of the centre frequency for devices operating above 70 MHz and below 900 MHz. For devices operating above 900 MHz, the emission shall be no wider than 0.5% of the centre frequency. Bandwidth is determined at the points 20 dB down from the modulated carrier.
Test Procedure:	<ol style="list-style-type: none"> 1. According to the follow Test-setup, keep the relative position between the artificial antenna and the EUT. 2. Set the EUT to proper test channel. 3. Max hold the radiated emissions, mark the peak power frequency point and the -20dB upper and lower frequency points. 4. Read 20dB bandwidth.
Test setup:	 <p>The diagram illustrates the test setup. A Spectrum Analyzer is connected via a red cable to an E.U.T. (Equipment Under Test). Both are placed on a Non-Conducted Table. Below the table is a Ground Reference Plane.</p>
Test Instruments:	Refer to section 4.7 for details
Test mode:	Transmitting mode
Test results:	Passed

Measurement Data

20dB bandwidth (KHz)	Limit (KHz)	Results
170	1085	Pass



Test plot as follows:

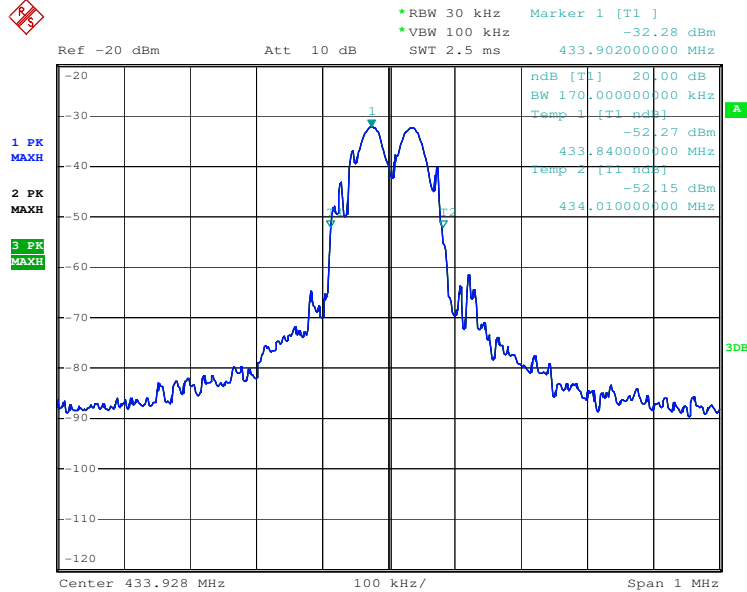

"This document is issued by the Company subject to its General Conditions of Service printed overleaf, available on request or accessible at www.sgs.com/terms_and_conditions.htm and, for electronic format documents, subject to Terms and Conditions for Electronic Documents at www.sgs.com/terms_e-document.htm. Attention is drawn to the limitation of liability, indemnification and jurisdiction issues defined therein. Any holder of this document is advised that information contained hereon reflects the Company's findings at the time of its intervention only and within the limits of Client's instructions, if any. The Company's sole responsibility is to its Client and this document does not exonerate parties to a transaction from exercising all their rights and obligations under the transaction documents. This document cannot be reproduced except in full, without prior written approval of the Company. Any unauthorized alteration, forgery or falsification of the content or appearance of this document is unlawful and offenders may be prosecuted to the fullest extent of the law. Unless otherwise stated the results shown in this test report refer only to the sample(s) tested and such sample(s) are retained for 90 days only."

5.4 Transmit Time and Silent Period:

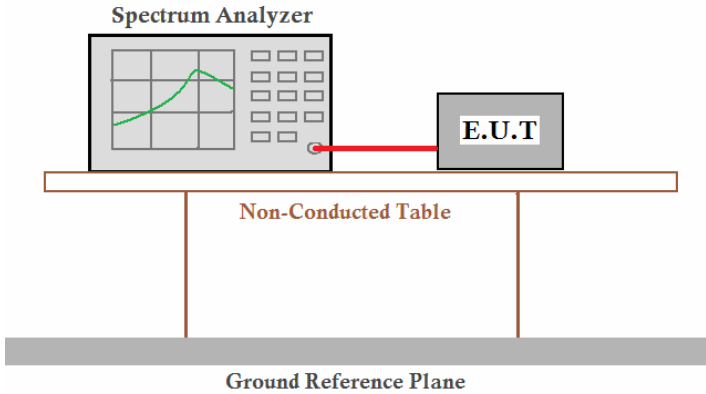
Test Requirement:	FCC Part15 C Section 15.231 (e)
Test Method:	ANSI C63.4:2003
Limit:	The duration of each transmission shall not be greater than one second The silent period shall be at least 30 times the transmit time but in no case less than 10 seconds.
Test Procedure:	1. According to the follow Test-setup, keep the relative position between the artificial antenna and the EUT. 2. Set the EUT to proper test channel. 3. Single scan the transmitter, and read the transmission time.
Test setup:	 <p>The diagram illustrates the test setup. A Spectrum Analyzer is connected via a red cable to an E.U.T. (Equipment Under Test). Both are placed on a Non-Conducted Table. Below the table is a Ground Reference Plane.</p>
Test Instruments:	Refer to section 4.7 for details
Test mode:	Transmitting mode
Test results:	Passed

Measurement Data

Test item	Test data	Limit (second)	Result
Transmitting time	58.5ms	1	Pass
Silent Period	12.0s	10	Pass



Test plot as follows:

Transmitting time:

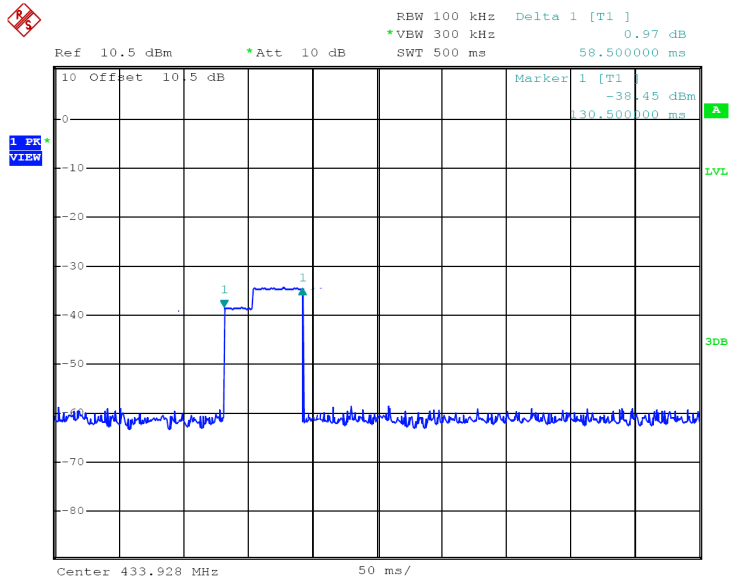

Silent Period:

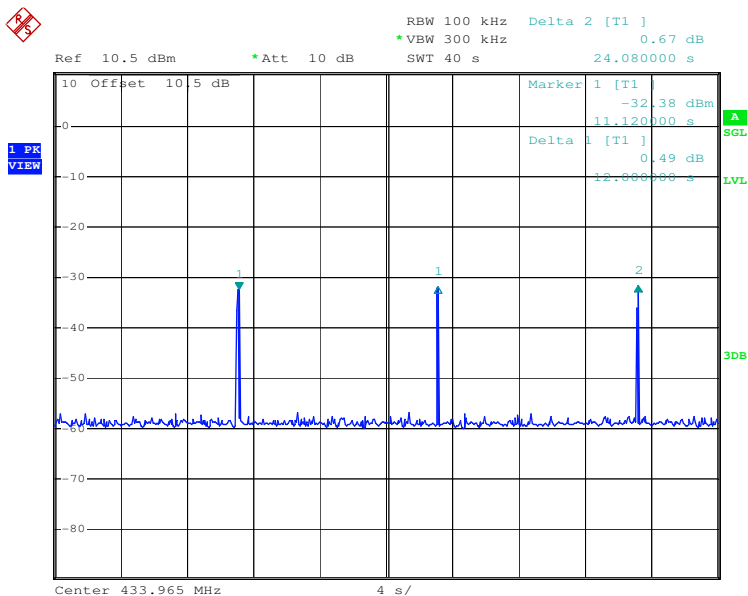

Date: 4.MAR.2010 08:43:20

"This document is issued by the Company subject to its General Conditions of Service printed overleaf, available on request or accessible at www.sgs.com/terms_and_conditions.htm and, for electronic format documents, subject to Terms and Conditions for Electronic Documents at www.sgs.com/terms_e-document.htm. Attention is drawn to the limitation of liability, indemnification and jurisdiction issues defined therein. Any holder of this document is advised that information contained hereon reflects the Company's findings at the time of its intervention only and within the limits of Client's instructions, if any. The Company's sole responsibility is to its Client and this document does not exonerate parties to a transaction from exercising all their rights and obligations under the transaction documents. This document cannot be reproduced except in full, without prior written approval of the Company. Any unauthorized alteration, forgery or falsification of the content or appearance of this document is unlawful and offenders may be prosecuted to the fullest extent of the law. Unless otherwise stated the results shown in this test report refer only to the sample(s) tested and such sample(s) are retained for 90 days only."