

RF TEST REPORT

Applicant ID TECH
FCC ID WQJ-VP6825LE
Product VP6825
Brand ID TECH
Model VP6825-8101; VP6825-8101D
Report No. R2307A0810-R6
Issue Date August 22, 2023

TA Technology (Shanghai) Co., Ltd. tested the above equipment in accordance with the requirements in **FCC CFR47 Part 15C (2022)**. The test results show that the equipment tested is capable of demonstrating compliance with the requirements as documented in this report.

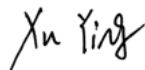

Prepared by: Xu Ying



Approved by: Xu Kai

TA Technology (Shanghai) Co., Ltd.

Building 3, No.145, Jintang Rd, Pudong Shanghai, P.R.China

TEL: +86-021-50791141/2/3

FAX: +86-021-50791141/2/3-8000

TABLE OF CONTENT

1	Test Laboratory.....	4
1.1	Notes of the Test Report.....	4
1.2.	Test facility.....	4
1.3	Testing Location.....	4
2	General Description of Equipment under Test.....	5
2.1	Applicant and Manufacturer Information.....	5
2.2	General information.....	5
3	Applied Standards.....	6
4	Information about the FHSS characteristics.....	7
4.1	Frequency Hopping System Requirement.....	7
4.2	Pseudorandom Frequency Hopping Sequence.....	8
4.3	Equal Hopping Frequency Use.....	9
4.4	System Receiver Input Bandwidth.....	9
4.5	Test Configuration.....	10
5	Test Case Results.....	11
5.1	Unwanted Emission.....	11
5.2	Conducted Emission.....	32
6	Main Test Instruments.....	35
	ANNEX A: The EUT Appearance.....	36
	ANNEX B: Test Setup Photos.....	37

Summary of Measurement Results

Number	Test Case	Clause in FCC rules	Verdict
1	Unwanted Emissions	15.247(d),15.205,15.209	PASS
2	Conducted Emissions	15.207	PASS
Date of Testing: (Original) November 2, 2022 ~ December 29, 2022			
Date of Sample Received: (Original) October 13, 2022			
Note: PASS: The EUT complies with the essential requirements in the standard. FAIL: The EUT does not comply with the essential requirements in the standard. All indications of Pass/Fail in this report are opinions expressed by TA Technology (Shanghai) Co., Ltd. based on interpretations and/or observations of test results. Measurement Uncertainties were not taken into account and are published for informational purposes only.			

VP6825-8101; VP6825-8101D (Report No.: R2307A0810-R6) is a variant model of VP6825-8100; VP6825-8100D (FCC ID: WQJ-VP6825L; Report No.: R2210A0932-R6V1).

For VP6825-8101; VP6825-8101D, test values all duplicated from Original for variant. There is no test for VP6825-8101; VP6825-8101D in this report.

For VP6825-8100; VP6825-8100D, only test Unwanted Emissions and Conducted Emissions.

Other test items refer to the module report (FCC ID: VPYLBEE5HY1MW; Report No.: 1802WSU008-U2).

1 Test Laboratory

1.1 Notes of the Test Report

This report shall not be reproduced in full or partial, without the written approval of **TA Technology (Shanghai) Co., Ltd.** The results documented in this report apply only to the tested sample, under the conditions and modes of operation as described herein. Measurement Uncertainties were not taken into account and are published for informational purposes only. This report is written to support regulatory compliance of the applicable standards stated above.

1.2. Test facility

FCC (Designation number: CN1179, Test Firm Registration Number: 446626)

TA Technology (Shanghai) Co., Ltd. has been listed on the US Federal Communications Commission list of test facilities recognized to perform measurements.

A2LA (Certificate Number: 3857.01)

TA Technology (Shanghai) Co., Ltd. has been listed by American Association for Laboratory Accreditation to perform measurement.

1.3 Testing Location

Company: TA Technology (Shanghai) Co., Ltd.
 Address: Building 3, No.145, Jintang Rd, Pudong Shanghai, P.R.China
 City: Shanghai
 Post code: 201201
 Country: P. R. China
 Contact: Xu Kai
 Telephone: +86-021-50791141/2/3
 Fax: +86-021-50791141/2/3-8000
 Website: <http://www.ta-shanghai.com>
 E-mail: xukai@ta-shanghai.com

2 General Description of Equipment under Test

2.1 Applicant and Manufacturer Information

Applicant	ID TECH
Applicant address	10721 Walker Street, Cypress, California 90630, United States
Manufacturer	ID TECH TAIWAN
Manufacturer address	No. 16, Lane 22, GaoQing Rd., YanMei Dist., TaoYuan City 326, Taiwan

2.2 General information

EUT Description			
Model	VP6825-8101; VP6825-8101D		
SN	(Original) 226K000755		
Hardware Version	Rev.A		
Software Version	v1.00		
Power Supply	External power supply		
Antenna Type	PIFA Antenna		
Antenna Connector	A permanently attached antenna (meet with the standard FCC Part 15.203 requirement)		
Antenna Gain	1.80 dBi		
Test Mode(s)	Basic Rate	Enhanced Data Rate(EDR)	
Modulation Type	Frequency Hopping Spread Spectrum (FHSS)		
	GFSK	$\pi/4$ DQPSK	8DPSK
Packet Type (Maximum Payload)	DH5	2DH5	3DH5
Operating Frequency Range(s)	2402-2480 MHz		
<p>Note: 1. The EUT is sent from the applicant to TA and the information of the EUT is declared by the applicant.</p> <p>2. VP6825-8101 and VP6825-8101D are the same except for different models.</p>			

3 Applied Standards

According to the specifications of the manufacturer, it must comply with the requirements of the following standards:

Test standards:

FCC CFR47 Part 15C (2022) Radio Frequency Devices

ANSI C63.10-2013

Reference standard:

KDB 558074 D01 15.247 Meas Guidance v05r02

4 Information about the FHSS characteristics

4.1 Frequency Hopping System Requirement

Standard requirement:

(g) Frequency hopping spread spectrum systems are not required to employ all available hopping channels during each transmission. However, the system, consisting of both the transmitter and the receiver, must be designed to comply with all of the regulations in this section should the transmitter be presented with a continuous data (or information) stream. In addition, a system employing short transmission bursts must comply with the definition of a frequency hopping system and must distribute its transmissions over the minimum number of hopping channels specified in this section.

(h) The incorporation of intelligence within a frequency hopping spread spectrum system that permits the system to recognize other users within the spectrum band so that it individually and independently chooses and adapts its hop sets to avoid hopping on occupied channels is permitted. The coordination of frequency hopping systems in any other manner for the express purpose of avoiding the simultaneous occupancy of individual hopping frequencies by multiple transmitters is not permitted.

Compliance for section 15.247(g):

According to Bluetooth Core Specification, the Bluetooth system transmits the packets with the pseudorandom hopping frequency with a continuous data and short burst transmission from the Bluetooth system is also transmitted under the frequency hopping system with the pseudorandom hopping frequency system.

Compliance for section 15.247(h):

According to Bluetooth Core Specification, the Bluetooth system incorporates with an adaptive system to detect other user within the spectrum band so that it individually and independently to avoid hopping on the occupied channels.

According to Bluetooth Core Specification, the Bluetooth system is designed not have the ability to coordinate with other FHSS System in an effort to avoid the simultaneous occupancy of individual hopping frequencies by multiple transmitter.

4.2 Pseudorandom Frequency Hopping Sequence

Frequency Hopping Systems. A spread spectrum system in which the carrier is modulated with the coded information in a conventional manner causing a conventional spreading of the RF energy about the frequency carrier. The frequency of the carrier is not fixed but changes at fixed intervals under the direction of a coded sequence. The wide RF bandwidth needed by such a system is not required by spreading of the RF energy about the carrier but rather to accommodate the range of frequencies to which the carrier frequency can hop. The test of a frequency hopping system is that the near term distribution of hops appears random, the long term distribution appears evenly distributed over the hop set, and sequential hops are randomly distributed in both direction and magnitude of change in the hop set.

Adaptive Frequency Hopping (AFH) was introduced in the Bluetooth specification to provide an effective way for a Bluetooth radio to counteract normal interference. AFH identifies "bad" channels, where either other wireless devices are interfering with the Bluetooth signal or the Bluetooth signal is interfering with another device. The AFH-enabled Bluetooth device will then communicate with other devices within its pioneer to share details of any identified bad channels. The devices will then switch to alternative available "good" channels, away from the areas of interference, thus having no impact on the bandwidth used.

The selection scheme chooses a segment of 32 hop frequencies spanning about 64 MHz and visits these hops in a pseudo-random order. Next, a different 32-hop segment is chosen, etc. In the page, master page response, slave page response, page scan, inquiry, inquiry response and inquiry scan hopping sequences, the same 32-hop segment is used all the time (the segment is selected by the address; different devices will have different paging segments).

When the basic channel hopping sequence is selected, the output constitutes a pseudo-random sequence that slides through the 79 hops. The principle is depicted in the figure below.

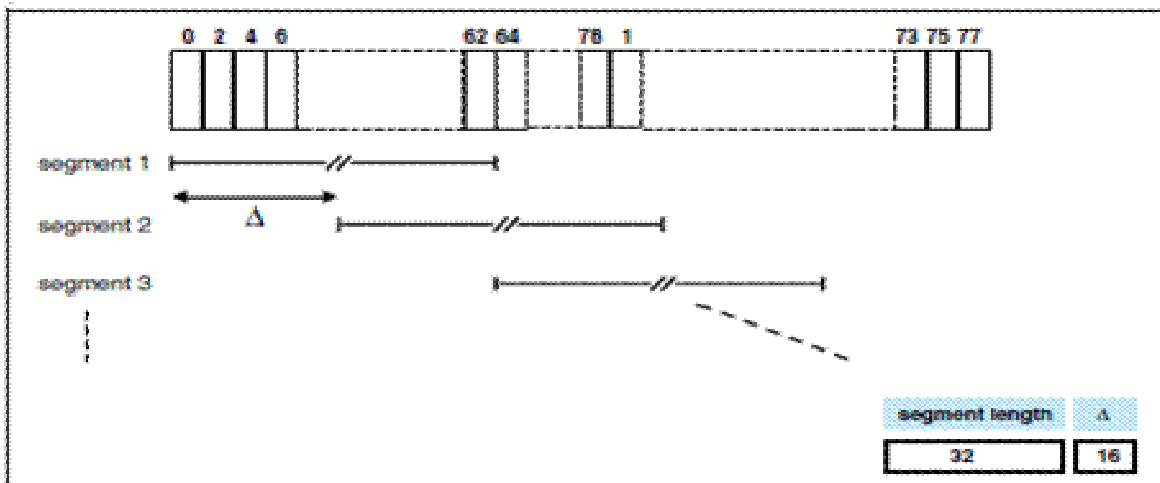

Hop selection scheme in CONNECTION state.

Pseudorandom Frequency Hopping Sequence Table as below:

Channel: 08, 24, 40, 56, 40, 56, 72, 09, 01, 09, 33, 41, 33, 41, 65, 73, 53, 69, 06, 22, 04, 20, 36, 52, 38, 46, 70, 78, 68, 76, 21, 29, 10, 26, 42, 58, 44, 60, 76, 13, 03, 11, 35, 43, 37, 45, 69, 77, 55, 71, 08, 24, 08, 24, 40, 56, 40, 48, 72, 01, 72, 01, 25, 33, 12, 28, 44, 60, 42, 58, 74, 11, 05, 13, 37, 45, etc.

Each frequency used equally on the average by each transmitter.

The system receiver have input bandwidths that match the hopping channel bandwidths of their corresponding transmitters and shift frequencies in synchronization with the transmitted signals.

4.3 Equal Hopping Frequency Use

All Bluetooth units participating in the Pico net are time and hop-synchronized to the channel. Each new transmission event begins on the next channel in the hopping sequence after the final channel used in the previous transmission event.

4.4 System Receiver Input Bandwidth

Each channel bandwidth is 1MHz. The system receivers have input bandwidths that match the hopping channel bandwidths of their corresponding transmitters and shift frequencies in synchronization with the transmitted signals.

4.5 Test Configuration

The EUT has been associated with peripherals and configuration operated in a manner tended to maximize its emission characteristics in a typical application.

The radiated emission was measured in the following position: EUT stand-up position (Z axis), lie-down position (X, Y axis). The worst emission was found in lie-down position (X axis) and the worst case was recorded.

Test Cases	Test Modes
Unwanted Emission	DH5/2DH5/3DH5
Conducted Emission	DH5/2DH5/3DH5

5 Test Case Results

5.1 Unwanted Emission

Ambient condition

Temperature	Relative humidity
20°C ~ 25°C	45% ~ 50%

Method of Measurement

The test set-up was made in accordance to the general provisions of ANSI C63.10. The Equipment Under Test (EUT) was set up on a non-conductive table in the semi-anechoic chamber. The test was performed at the distance of 3 m between the EUT and the receiving antenna. The radiated emissions measurements were made in a typical installation configuration.

Sweep the whole frequency band through the range from 9 kHz to the 10th harmonic of the carrier, and the emissions less than 20 dB below the permissible value are reported.

During the test, below 30MHz, the center of the loop shall be 1 meters; above 30MHz, the height of receive antenna shall be moved from 1 to 4 meters, and the antenna shall be performed under horizontal and vertical polarization. The turntable shall be rotated from 0 to 360 degrees for detecting the maximum of radiated spurious signal level. The measurements shall be repeated with orthogonal polarization of the test antenna. The data of cable loss and antenna factor has been calibrated in full testing frequency range before the testing.

Set the spectrum analyzer in the following:

9kHz~150 kHz

RBW=200Hz, VBW=1kHz/ Sweep=AUTO

150 kHz~30MHz

RBW=9KHz, VBW=30KHz,/ Sweep=AUTO

Below 1GHz

RBW=100kHz / VBW=300kHz / Sweep=AUTO

Above 1GHz

(a) PEAK: RBW=1MHz VBW=3MHz/ Sweep=AUTO

(b) AVERAGE: RBW=1MHz / VBW=3MHz / Sweep=AUTO

detector; The measurements employing a CISPR quasi-peak detector except for the frequency bands 9-90 kHz, 110-490 kHz and above 1000 MHz. Radiated emission limits in these three bands are based on measurements employing an average detector.

The dwell time per channel of the hopping signal is less than 100 ms, then the reading obtained with the 10 Hz VBW may be further adjusted by a "duty cycle correction factor", derived from $20\log(\text{dwell time}/100 \text{ ms})$, in an effort to demonstrate compliance with the 15.209 limit.

If the emission is pulsed, modify the unit for continuous operation; use the settings shown above, then correct the reading by subtracting the peak- average correction factor, derived form the appropriate duty cycle calculation.

This setting method can refer to **KDB 558074 D01**.

This mode was measured in the following mode: EUT with cradle and EUT without cradle. The worst emission was found in EUT with cradle mode and the worst case was recorded.

The test is in transmitting mode.

Test setup

9kHz~ 30MHz

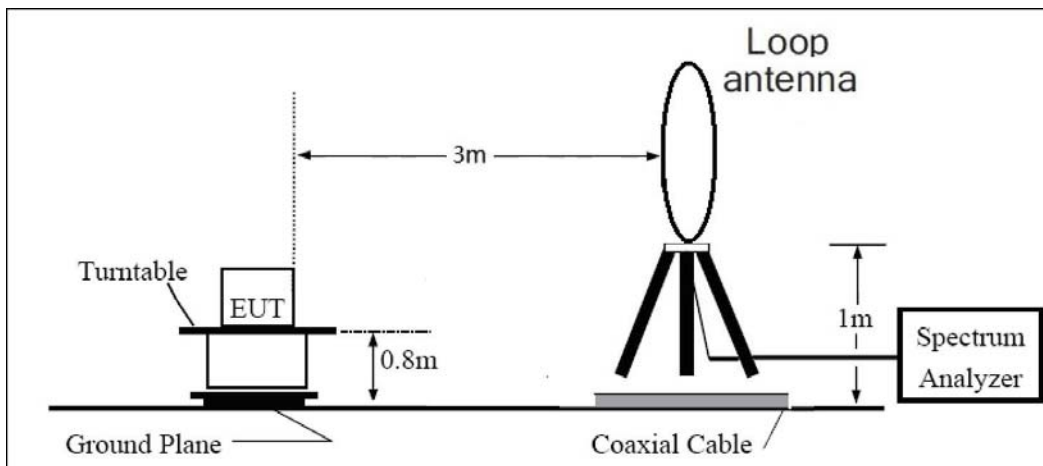

30MHz~ 1GHz

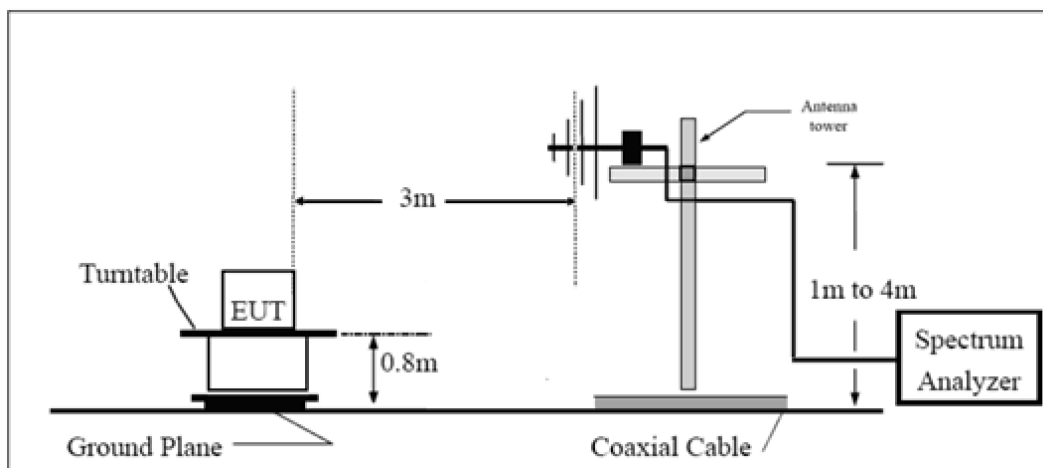

Above 1GHz

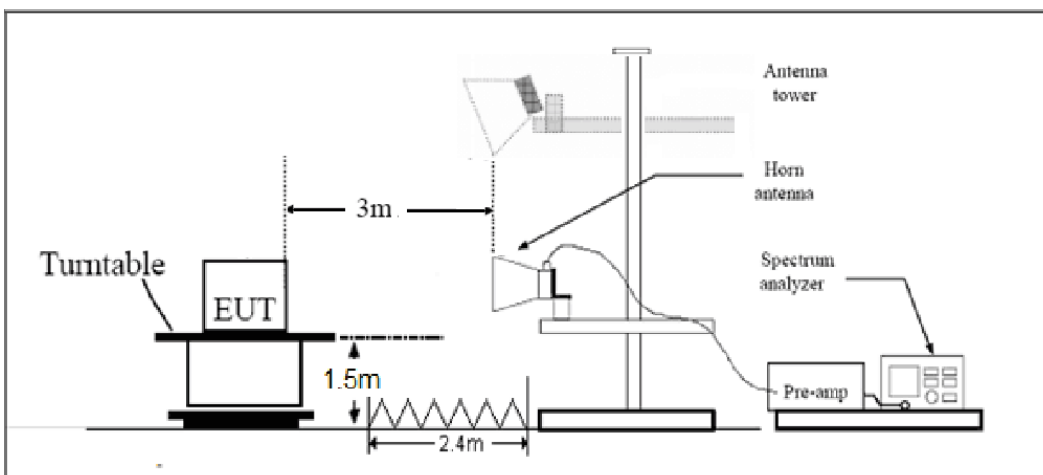

Note: Area side:2.4mX3.6m

Limits

Rule Part 15.247(d) specifies that “In addition, radiated emissions which fall in the restricted bands, as defined in § 15.205(a), must also comply with the radiated emission limits specified in § 15.209(a) (see § 15.205(c)).”

Limit in restricted band

Frequency of emission (MHz)	Field strength($\mu\text{V}/\text{m}$)	Field strength($\text{dB}\mu\text{V}/\text{m}$)
0.009–0.490	2400/F(kHz)	/
0.490–1.705	24000/F(kHz)	/
1.705–30.0	30	/
30-88	100	40
88-216	150	43.5
216-960	200	46
Above960	500	54

§15.35(b)

There is also a limit on the radio frequency emissions, as measured using instrumentation with a peak detector function, corresponding to 20 dB above the maximum permitted average limit.

Peak Limit=74dB $\mu\text{V}/\text{m}$

Average Limit=54dB $\mu\text{V}/\text{m}$

Spurious Radiated Emissions are permitted in any of the frequency bands listed below:

MHz	MHz	MHz	GHz
0.090-0.110	16.42-16.423	399.9-410	4.5-5.15
¹ 0.495-0.505	16.69475-16.69525	608-614	5.35-5.46
2.1735-2.1905	16.80425-16.80475	960-1240	7.25-7.75
4.125-4.128	25.5-25.67	1300-1427	8.025-8.5
4.17725-4.17775	37.5-38.25	1435-1626.5	9.0-9.2
4.20725-4.20775	73-74.6	1645.5-1646.5	9.3-9.5
6.215-6.218	74.8-75.2	1660-1710	10.6-12.7
6.26775-6.26825	108-121.94	1718.8-1722.2	13.25-13.4
6.31175-6.31225	123-138	2200-2300	14.47-14.5
8.291-8.294	149.9-150.05	2310-2390	15.35-16.2
8.362-8.366	156.52475-156.52525	2483.5-2500	17.7-21.4
8.37625-8.38675	156.7-156.9	2690-2900	22.01-23.12
8.41425-8.41475	162.0125-167.17	3260-3267	23.6-24.0
12.29-12.293	167.72-173.2	3332-3339	31.2-31.8
12.51975-12.52025	240-285	3345.8-3358	36.43-36.5
12.57675-12.57725	322-335.4	3600-4400	(²)
13.36-13.41			

Measurement Uncertainty

The assessed measurement uncertainty to ensure 95% confidence level for the normal distribution is with the coverage factor $k = 1.96$.

Frequency	Uncertainty
9KHz-30MHz	3.55 dB
30MHz-200MHz	4.17 dB
200MHz-1GHz	4.84 dB
1-18GHz	4.35 dB
18-26.5GHz	5.90 dB
26.5GHz~40GHz	5.92 dB

Test Results:

A symbol ($\text{dB } \mu\text{V/m}$) in the test plot below means (dB $\mu\text{V/m}$)

The signal beyond the limit is carrier.

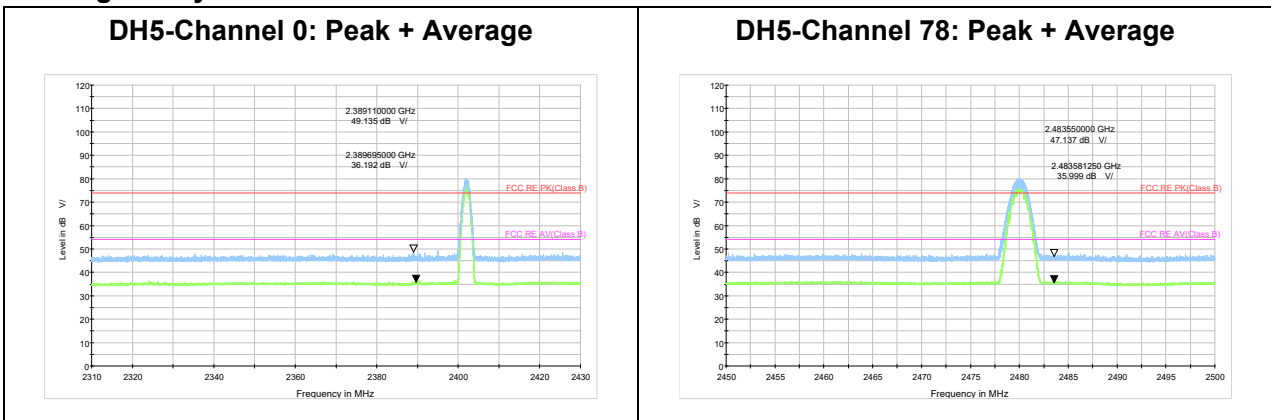

The bandage was performed in all EDR mode (2DH5 and 3DH5), 3DH5 was selected as the worse condition. The test data of the worst-case condition was recorded in this report.

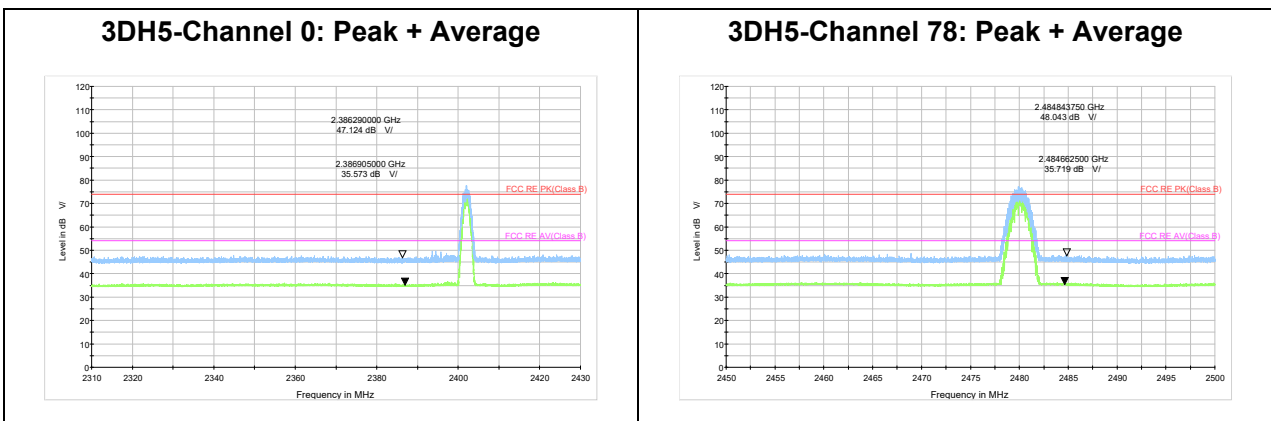

Result of RE

Test result

Sweep the whole frequency band through the range from 9kHz to the 10th harmonic of the carrier, the Emissions in the frequency band 9kHz-30MHz and 18GHz -26.5GHz are more than 20dB below the limit are not reported.

The following graphs display the maximum values of horizontal and vertical by software. For above 1GHz, Blue trace uses the peak detection, Green trace uses the average detection.

During the test, the Radiates Emission from 30MHz to 1GHz was performed in all modes with all channels, BT GFSK DH5-Channel 39 are selected as the worst condition. The test data of the worst-case condition was recorded in this report.

A symbol (dB V/) in the test plot below means (dBμV/m)

Continuous TX mode:

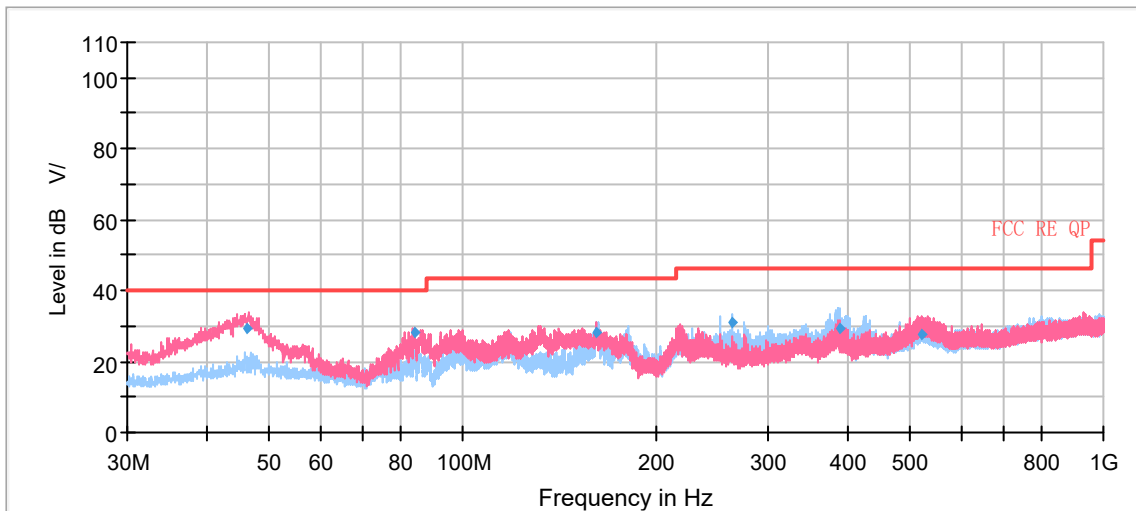

Radiates Emission from 30MHz to 1GHz

Frequency (MHz)	Quasi-Peak (dBμV/m)	Limit (dBμV/m)	Margin (dB)	Height (cm)	Polarization	Azimuth (deg)	Correct Factor (dB)
46.23	29.37	40.00	10.63	109.0	V	9.00	20
83.99	28.26	40.00	11.74	175.0	V	181.00	14
162.22	27.99	43.50	15.51	208.0	H	140.00	15
264.00	31.16	46.00	14.84	125.0	H	81.00	20
387.23	29.22	46.00	16.78	100.0	H	234.00	23
520.33	27.83	46.00	18.17	100.0	V	25.00	25

Remark: 1. Correction Factor = Antenna factor + Insertion loss (cable loss + amplifier gain)

2. Margin = Limit – Quasi-Peak

DH5-Channel 0

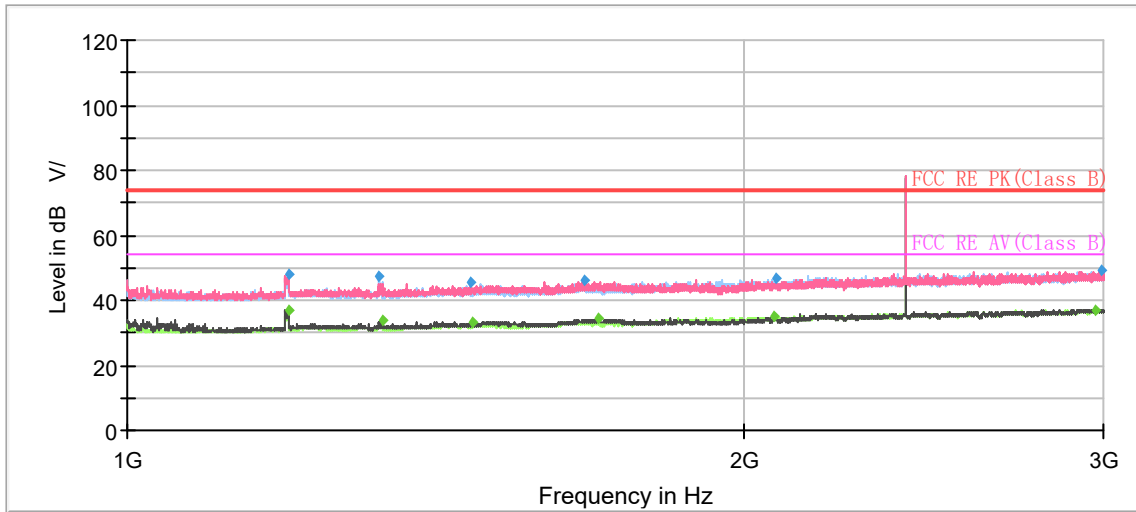

Note: The signal beyond the limit is carrier.
Radiates Emission from 1GHz to 3GHz

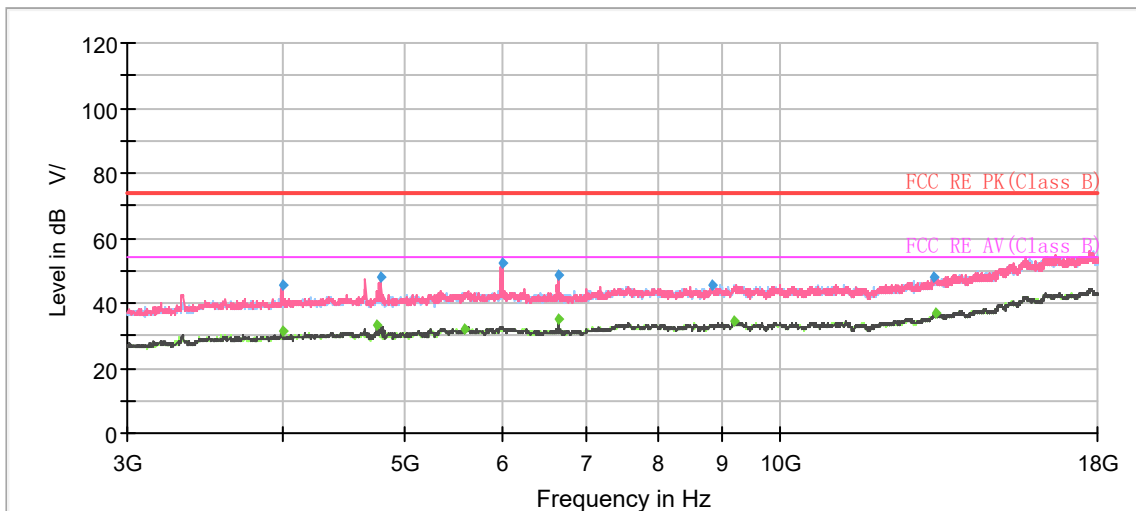

Radiates Emission from 3GHz to 18GHz

Frequency (MHz)	MaxPeak (dB μ V/m)	Average (dB μ V/m)	Limit (dB μ V/m)	Margin (dB)	Meas. Time (ms)	Height (cm)	Pol	Azimuth (deg)	Corr. (dB/m)
1198.75	---	36.86	54.00	17.14	500.00	200.0	V	140.00	-7
1198.75	47.90	---	74.00	26.10	500.00	200.0	V	140.00	-7
1328.50	47.23	---	74.00	26.77	500.00	200.0	H	175.00	-7
1332.00	---	34.05	54.00	19.95	500.00	200.0	V	175.00	-7
1471.75	45.71	---	74.00	28.29	500.00	100.0	V	94.00	-6
1475.50	---	33.24	54.00	20.76	500.00	200.0	V	339.00	-6
1671.00	46.06	---	74.00	27.94	500.00	100.0	V	80.00	-5
1700.25	---	34.25	54.00	19.75	500.00	200.0	V	175.00	-5
2070.00	---	35.05	54.00	18.95	500.00	200.0	H	212.00	-3
2074.50	46.57	---	74.00	27.43	500.00	200.0	H	207.00	-3
2973.50	---	37.21	54.00	16.79	500.00	100.0	H	99.00	1
2994.75	48.98	---	74.00	25.02	500.00	200.0	V	184.00	1

Remark: 1. Correction Factor = Antenna factor + Insertion loss (cable loss + amplifier gain)

2. Margin = Limit –MAX Peak/ Average

DH5-Channel 39

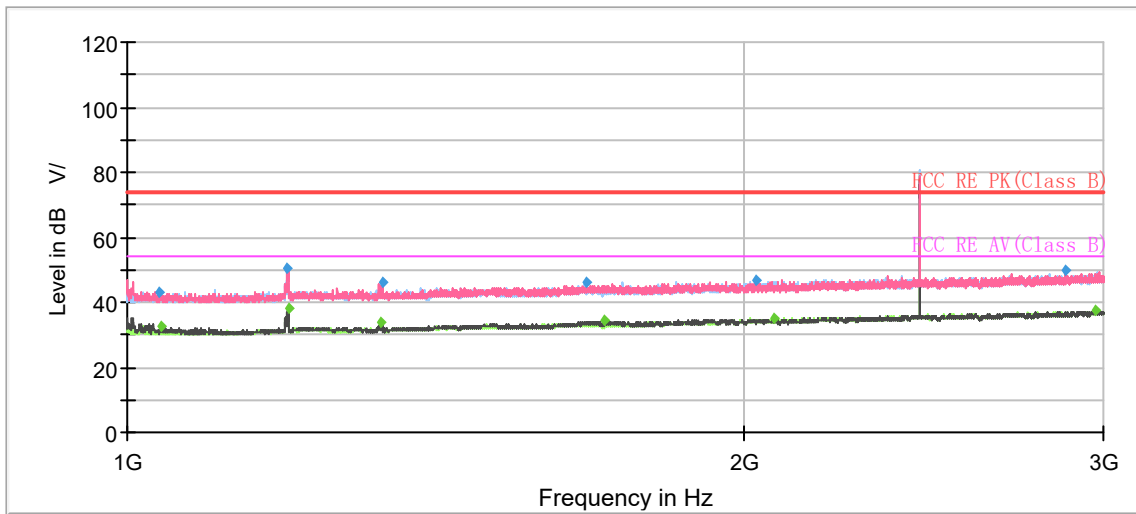

Note: The signal beyond the limit is carrier.
Radiates Emission from 1GHz to 3GHz

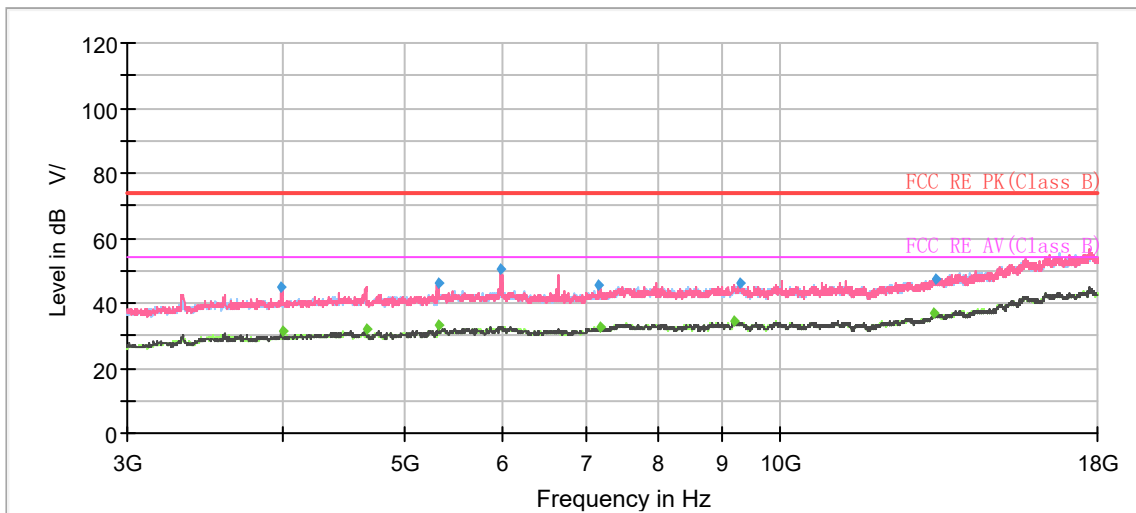

Radiates Emission from 3GHz to 18GHz

Frequency (MHz)	MaxPeak (dB μ V/m)	Average (dB μ V/m)	Limit (dB μ V/m)	Margin (dB)	Meas. Time (ms)	Height (cm)	Pol	Azimuth (deg)	Corr. (dB/m)
1036.25	43.37	---	74.00	30.63	500.00	100.0	H	245.00	-9
1039.00	---	32.33	54.00	21.67	500.00	200.0	V	120.00	-9
1198.00	50.20	---	74.00	23.80	500.00	200.0	V	232.00	-7
1198.25	---	38.36	54.00	15.64	500.00	200.0	V	232.00	-7
1331.50	---	33.93	54.00	20.07	500.00	100.0	H	227.00	-7
1332.50	46.15	---	74.00	27.85	500.00	200.0	V	9.00	-7
1675.00	45.97	---	74.00	28.03	500.00	200.0	H	87.00	-5
1712.25	---	34.18	54.00	19.82	500.00	200.0	V	255.00	-4
2030.50	46.99	---	74.00	27.01	500.00	200.0	H	0.00	-3
2072.75	---	34.84	54.00	19.16	500.00	100.0	V	242.00	-3
2877.50	49.56	---	74.00	24.44	500.00	200.0	V	89.00	1
2973.50	---	37.25	54.00	16.75	500.00	200.0	H	0.00	1

Remark: 1. Correction Factor = Antenna factor + Insertion loss (cable loss + amplifier gain)

2. Margin = Limit - MAX Peak/ Average

DH5-Channel 78

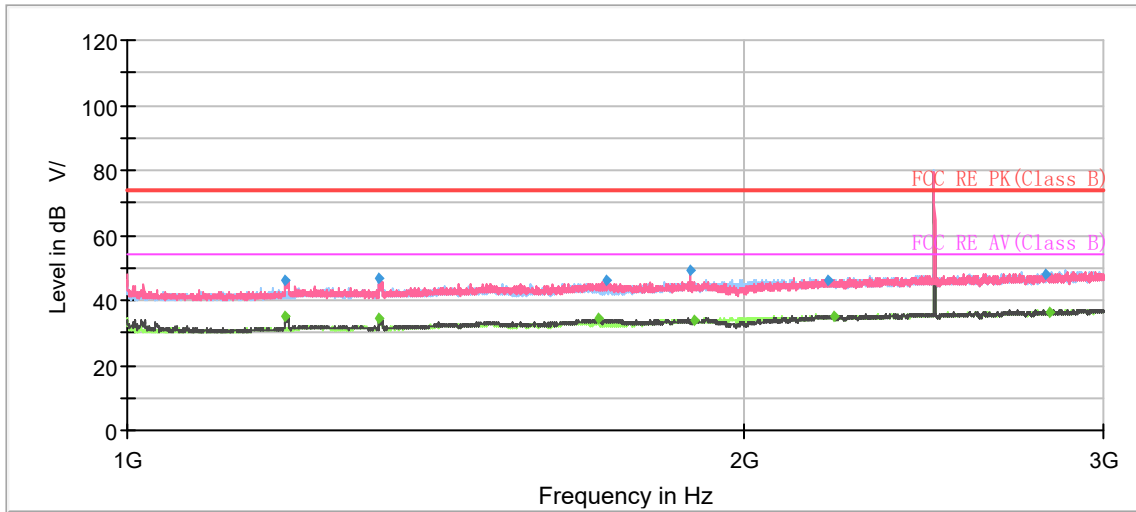

Note: The signal beyond the limit is carrier.
Radiates Emission from 1GHz to 3GHz

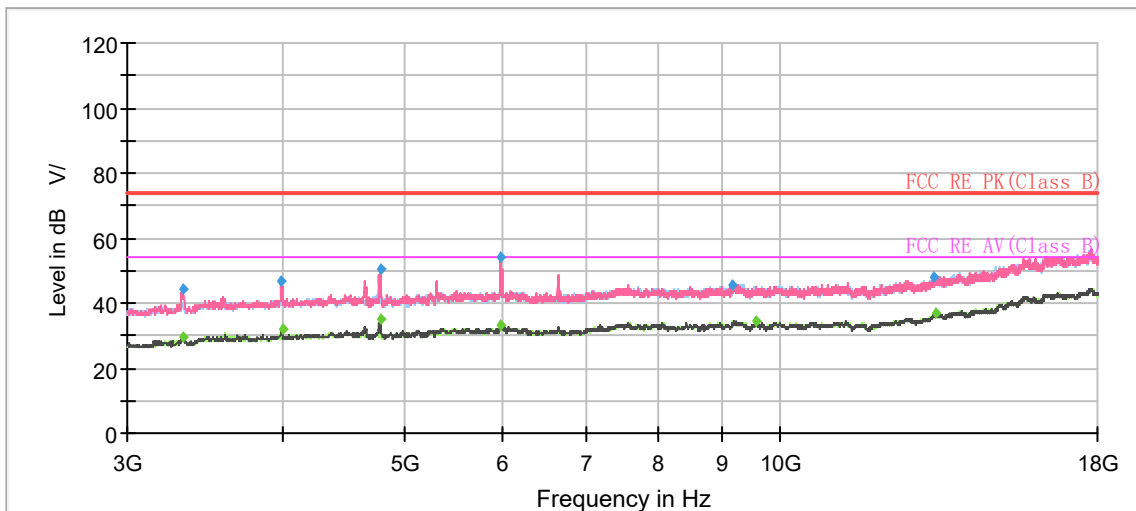

Radiates Emission from 3GHz to 18GHz

Frequency (MHz)	MaxPeak (dB μ V/m)	Average (dB μ V/m)	Limit (dB μ V/m)	Margin (dB)	Meas. Time (ms)	Height (cm)	Pol	Azimuth (deg)	Corr. (dB/m)
1195.00	---	35.29	54.00	18.71	500.00	100.0	V	358.00	-7
1195.00	46.38	---	74.00	27.62	500.00	100.0	V	358.00	-7
1327.50	---	34.73	54.00	19.27	500.00	200.0	H	172.00	-7
1327.50	46.67	---	74.00	27.33	500.00	200.0	H	172.00	-7
1700.25	---	34.33	54.00	19.67	500.00	200.0	V	188.00	-5
1716.00	45.92	---	74.00	28.08	500.00	100.0	V	0.00	-4
1886.00	49.34	---	74.00	24.66	500.00	200.0	V	192.00	-4
1894.50	---	33.84	54.00	20.16	500.00	100.0	H	174.00	-3
2198.25	46.42	---	74.00	27.58	500.00	200.0	V	248.00	-2
2214.25	---	35.09	54.00	18.91	500.00	100.0	H	249.00	-2
2813.75	47.70	---	74.00	26.30	500.00	100.0	V	74.00	0
2825.50	---	36.49	54.00	17.51	500.00	100.0	H	359.00	1
13338.75	---	37.06	54.00	16.94	500.00	200.0	V	289.00	7

Remark: 1. Correction Factor = Antenna factor + Insertion loss (cable loss + amplifier gain)

2. Margin = Limit - MAX Peak/ Average

During the test, the Radiates Emission from 18GHz to 26.5GHz was performed in all modes with all channels, BT GFSK DH5-Channel 39 are selected as the worst condition. The test data of the worst-case condition was recorded in this report.

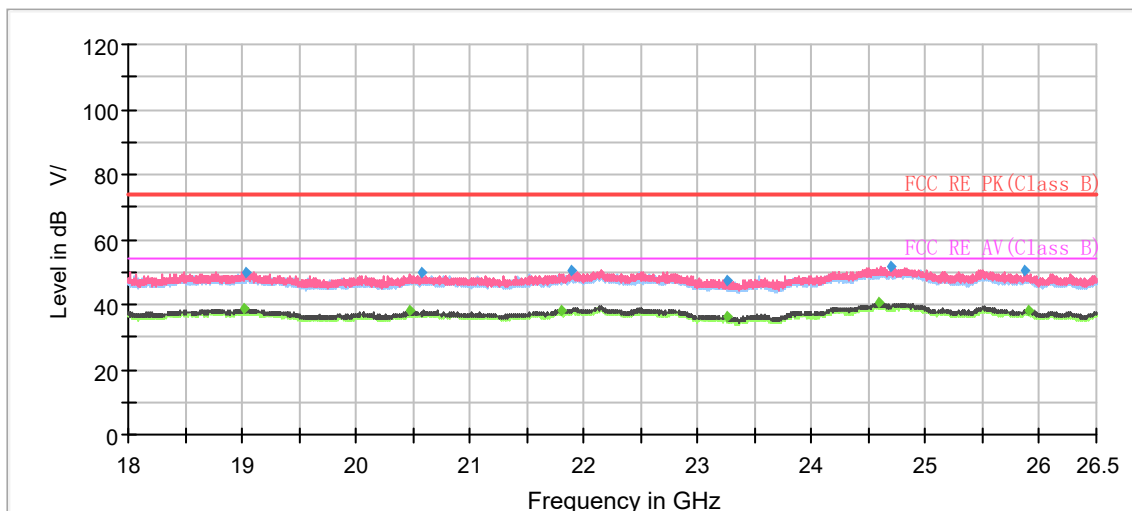

Radiates Emission from 18GHz to 26.5GHz

Frequency (MHz)	MaxPeak (dBμV/m)	Average (dBμV/m)	Limit (dBμV/m)	Margin (dB)	Meas. Time (ms)	Height (cm)	Pol	Azimuth (deg)	Corr. (dB/m)
19014.69	---	38.87	54.00	15.13	500.00	100.0	V	0.00	-6
19040.19	49.92	---	74.00	24.08	500.00	100.0	V	106.00	-6
20472.44	---	37.96	54.00	16.04	500.00	100.0	V	75.00	-6
20568.06	49.99	---	74.00	24.01	500.00	100.0	V	161.00	-6
21806.94	---	38.12	54.00	15.88	500.00	100.0	V	343.00	-5
21882.38	50.46	---	74.00	23.54	500.00	100.0	V	127.00	-5
23253.00	---	36.00	54.00	18.00	500.00	100.0	V	117.00	-6
23257.25	47.30	---	74.00	26.70	500.00	100.0	V	161.00	-6
24598.13	---	40.35	54.00	13.65	500.00	100.0	V	15.00	-2
24696.94	51.76	---	74.00	22.24	500.00	100.0	V	1.00	-1
25876.31	50.73	---	74.00	23.27	500.00	100.0	V	11.00	-3
25908.19	---	38.03	54.00	15.97	500.00	100.0	V	97.00	-3

Remark: 1. Correction Factor = Antenna factor + Insertion loss (cable loss + amplifier gain)

2. Margin = Limit - MAX Peak/ Average

During the test, the Radiates Emission from 30MHz to 1GHz was performed in all EDR mode (2DH5 and 3DH5) with all channels, BT 8DPSK 3DH5-Channel 78 are selected as the worst condition. The test data of the worst-case condition was recorded in this report.

A symbol (dB V/) in the test plot below means (dBμV/m)

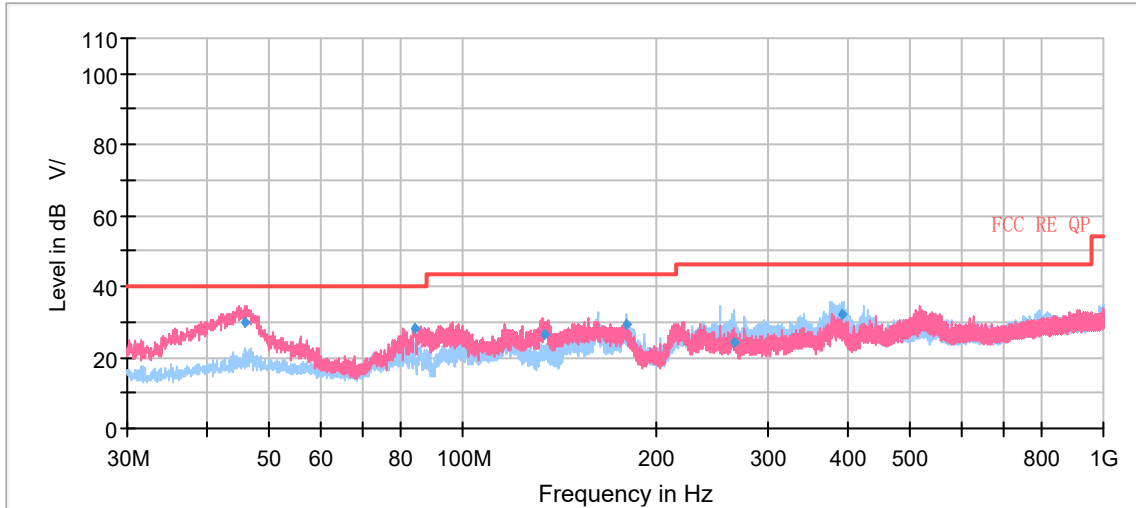

Radiates Emission from 30MHz to 1GHz

Frequency (MHz)	Quasi-Peak (dBμV/m)	Limit (dBμV/m)	Margin (dB)	Height (cm)	Polarization	Azimuth (deg)	Correct Factor (dB)
45.82	29.74	40.00	10.26	100.0	V	330.00	20
84.00	28.30	40.00	11.70	175.0	V	186.00	14
134.16	26.65	43.50	16.85	100.0	V	143.00	15
179.99	29.11	43.50	14.39	207.0	H	58.00	16
266.30	24.48	46.00	21.52	125.0	H	70.00	20
391.33	32.12	46.00	13.88	100.0	H	241.00	23

Remark: 1. Correction Factor = Antenna factor + Insertion loss (cable loss + amplifier gain)
 2. Margin = Limit – Quasi-Peak

3DH5-Channel 0

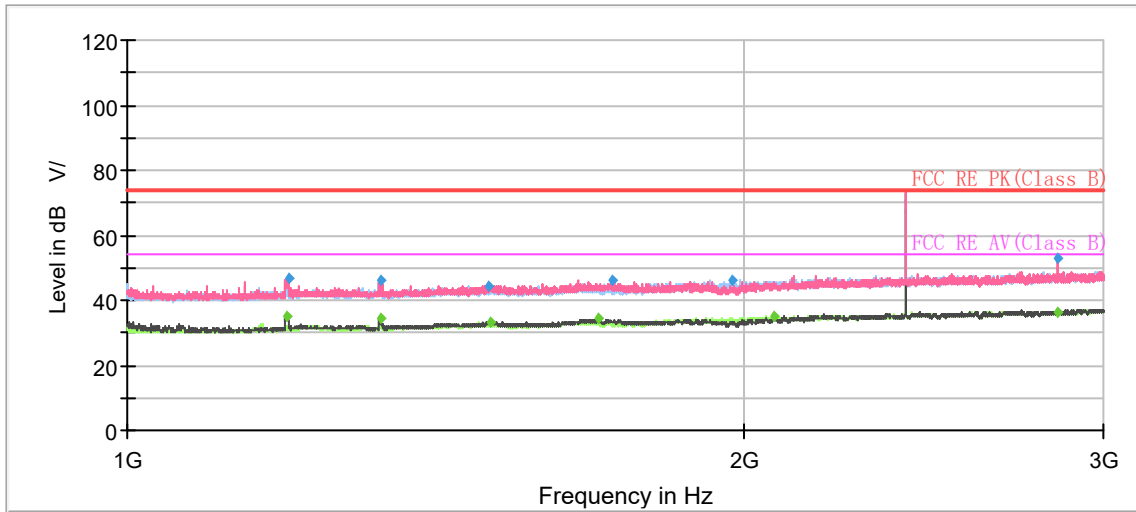

Note: The signal beyond the limit is carrier.
Radiates Emission from 1GHz to 3GHz

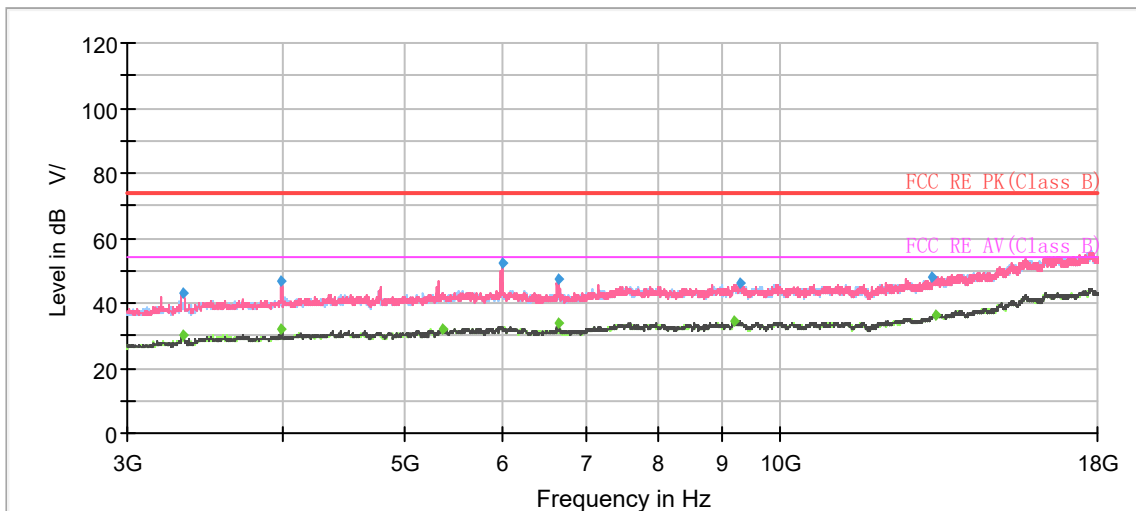

Radiates Emission from 3GHz to 18GHz

Frequency (MHz)	MaxPeak (dB μ V/m)	Average (dB μ V/m)	Limit (dB μ V/m)	Margin (dB)	Meas. Time (ms)	Height (cm)	Pol	Azimuth (deg)	Corr. (dB/m)
1196.50	---	35.26	54.00	18.74	500.00	200.0	V	141.00	-7
1198.25	46.73	---	74.00	27.27	500.00	200.0	V	141.00	-7
1329.00	46.34	---	74.00	27.66	500.00	100.0	V	108.00	-7
1329.50	---	34.75	54.00	19.25	500.00	200.0	V	188.00	-7
1500.25	44.38	---	74.00	29.62	500.00	100.0	V	42.00	-6
1504.25	---	33.14	54.00	20.86	500.00	100.0	V	0.00	-6
1700.25	---	34.27	54.00	19.73	500.00	200.0	V	188.00	-5
1724.75	46.13	---	74.00	27.87	500.00	200.0	V	188.00	-4
1974.50	46.35	---	74.00	27.65	500.00	200.0	H	291.00	-3
2072.00	---	34.81	54.00	19.19	500.00	100.0	H	265.00	-3
2846.50	53.07	---	74.00	20.93	500.00	200.0	V	272.00	1
2852.00	---	36.55	54.00	17.45	500.00	100.0	H	0.00	1

Remark: 1. Correction Factor = Antenna factor + Insertion loss (cable loss + amplifier gain)

2. Margin = Limit –MAX Peak/ Average

3DH5-Channel 39

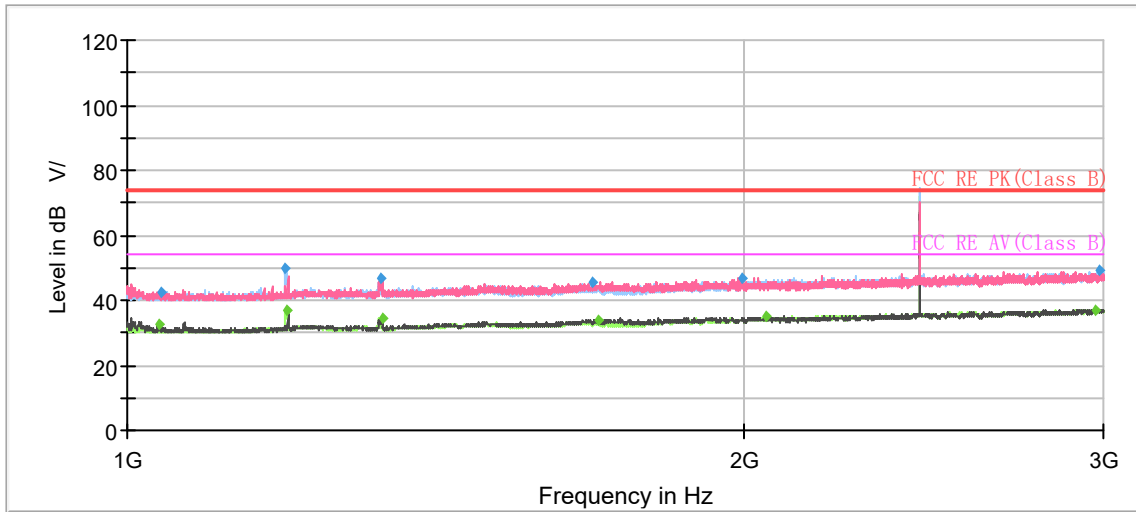

Note: The signal beyond the limit is carrier.
Radiates Emission from 1GHz to 3GHz

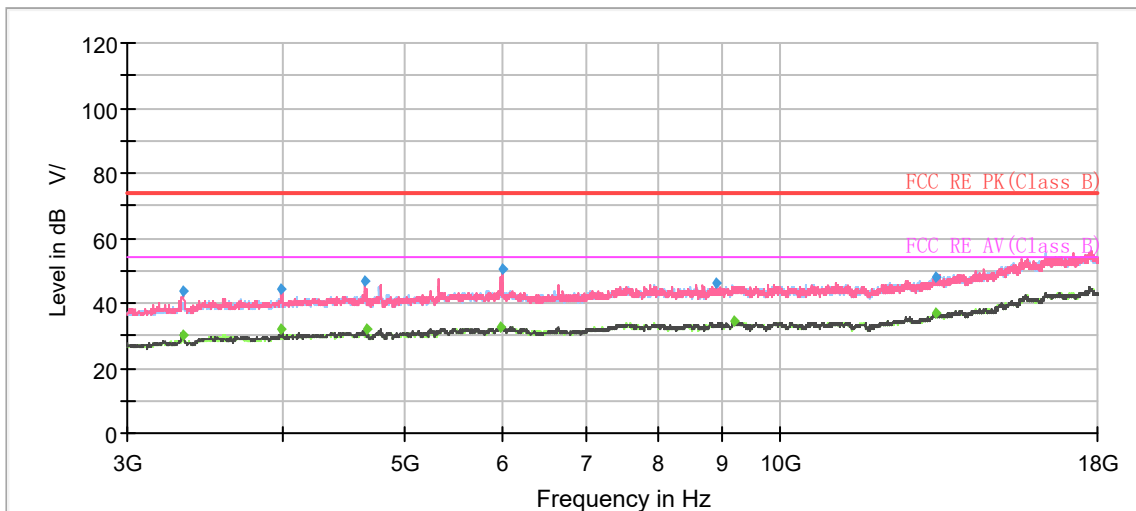

Radiates Emission from 3GHz to 18GHz

Frequency (MHz)	MaxPeak (dB μ V/m)	Average (dB μ V/m)	Limit (dB μ V/m)	Margin (dB)	Meas. Time (ms)	Height (cm)	Pol	Azimuth (deg)	Corr. (dB/m)
1036.25	---	32.42	54.00	21.58	500.00	200.0	V	288.00	-9
1038.50	42.53	---	74.00	31.47	500.00	100.0	H	155.00	-9
1195.00	49.61	---	74.00	24.39	500.00	100.0	H	182.00	-7
1195.75	---	36.94	54.00	17.06	500.00	100.0	H	182.00	-7
1329.25	46.94	---	74.00	27.06	500.00	200.0	V	192.00	-7
1332.75	---	34.42	54.00	19.58	500.00	200.0	V	197.00	-7
1687.25	45.44	---	74.00	28.56	500.00	200.0	V	238.00	-5
1700.00	---	34.15	54.00	19.85	500.00	200.0	V	188.00	-5
1998.75	46.93	---	74.00	27.07	500.00	100.0	V	257.00	-3
2052.25	---	34.85	54.00	19.15	500.00	100.0	H	350.00	-3
2971.25	---	37.17	54.00	16.83	500.00	200.0	H	0.00	1
2987.00	49.19	---	74.00	24.81	500.00	200.0	H	85.00	1

Remark: 1. Correction Factor = Antenna factor + Insertion loss (cable loss + amplifier gain)

2. Margin = Limit –MAX Peak/ Average

3DH5-Channel 78

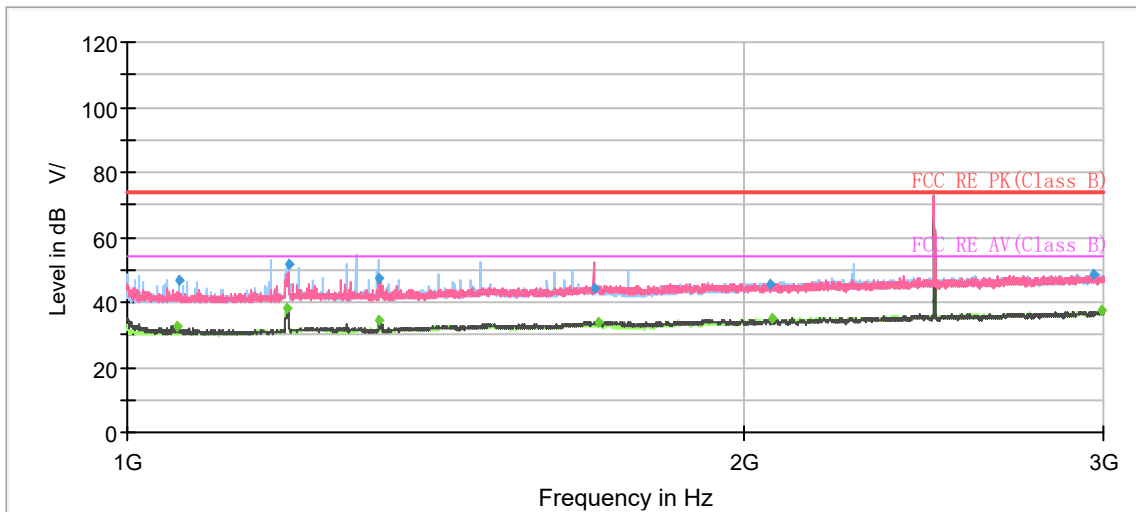

Note: The signal beyond the limit is carrier.
Radiates Emission from 1GHz to 3GHz

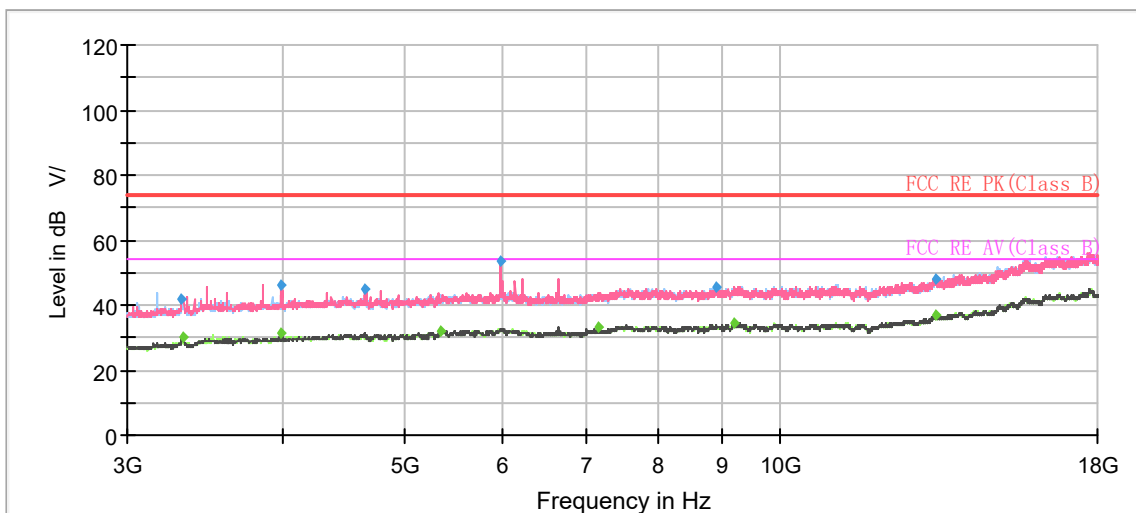

Radiates Emission from 3GHz to 18GHz

Frequency (MHz)	MaxPeak (dB μ V/m)	Average (dB μ V/m)	Limit (dB μ V/m)	Margin (dB)	Meas. Time (ms)	Height (cm)	Pol	Azimuth (deg)	Corr. (dB/m)
1056.75	---	32.48	54.00	21.52	500.00	200.0	V	128.00	-8
1060.00	46.85	---	74.00	27.15	500.00	100.0	H	249.00	-8
1197.50	---	37.93	54.00	16.07	500.00	200.0	H	115.00	-7
1198.75	51.72	---	74.00	22.28	500.00	200.0	H	115.00	-7
1328.00	47.39	---	74.00	26.61	500.00	200.0	V	119.00	-7
1328.25	---	34.28	54.00	19.72	500.00	100.0	V	0.00	-7
1690.75	44.18	---	74.00	29.82	500.00	200.0	H	212.00	-5
1699.75	---	33.97	54.00	20.03	500.00	200.0	V	183.00	-5
2059.25	45.82	---	74.00	28.18	500.00	100.0	V	98.00	-3
2066.75	---	34.86	54.00	19.14	500.00	200.0	H	110.00	-3
2963.75	48.84	---	74.00	25.16	500.00	100.0	V	227.00	1
2990.50	---	37.33	54.00	16.67	500.00	200.0	H	338.00	1

Remark: 1. Correction Factor = Antenna factor + Insertion loss (cable loss + amplifier gain)

2. Margin = Limit –MAX Peak/ Average

During the test, the Radiates Emission from 18GHz to 26.5GHz was performed in all modes with all channels, BT 8DPSK 3DH5-Channel 78 are selected as the worst condition. The test data of the worst-case condition was recorded in this report.

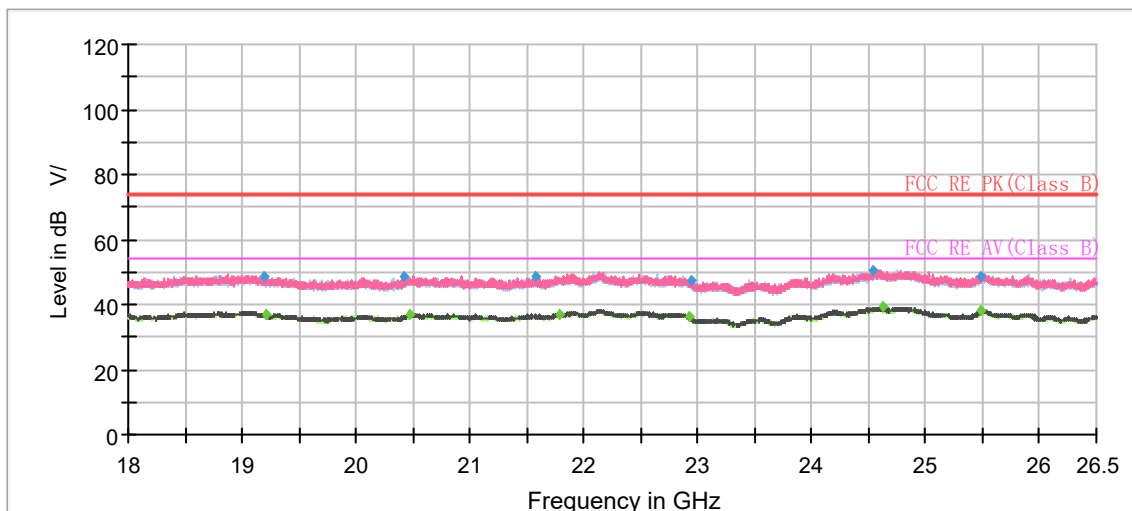

Radiates Emission from 18GHz to 26.5GHz

Frequency (MHz)	MaxPeak (dB μ V/m)	Average (dB μ V/m)	Limit (dB μ V/m)	Margin (dB)	Meas. Time (ms)	Height (cm)	Pol	Azimuth (deg)	Corr. (dB/m)
19199.56	48.38	---	74.00	25.62	500.00	200.0	V	134.00	-7
19209.13	---	36.94	54.00	17.06	500.00	100.0	V	39.00	-7
20425.69	48.37	---	74.00	25.63	500.00	100.0	V	30.00	-7
20465.00	---	36.89	54.00	17.11	500.00	200.0	H	247.00	-6
21571.06	48.87	---	74.00	25.13	500.00	200.0	V	206.00	-6
21783.56	---	37.19	54.00	16.81	500.00	200.0	V	0.00	-5
22920.44	---	36.32	54.00	17.68	500.00	100.0	V	19.00	-5
22941.69	47.44	---	74.00	26.56	500.00	100.0	V	115.00	-5
24530.13	50.67	---	74.00	23.33	500.00	200.0	H	175.00	-2
24627.88	---	39.11	54.00	14.89	500.00	200.0	V	113.00	-2
25483.19	48.43	---	74.00	25.57	500.00	200.0	H	160.00	-2
25485.31	---	38.16	54.00	15.84	500.00	200.0	H	206.00	-2

Remark: 1. Correction Factor = Antenna factor + Insertion loss (cable loss + amplifier gain)

2. Margin = Limit - MAX Peak/ Average

5.2 Conducted Emission

Ambient condition

Temperature	Relative humidity
20°C ~ 25°C	45% ~ 50%

Methods of Measurement

The EUT is placed on a non-metallic table of 80cm height above the horizontal metal reference ground plane. During the test, the EUT was operating in its typical mode. The test method is according to ANSI C63.10. Connect the AC power line of the EUT to the L.I.S.N. Use EMI receiver to detect the average and Quasi-peak value. RBW is set to 9 kHz, VBW is set to 30kHz. The measurement result should include both L line and N line.

The test is in transmitting mode.

Test Setup

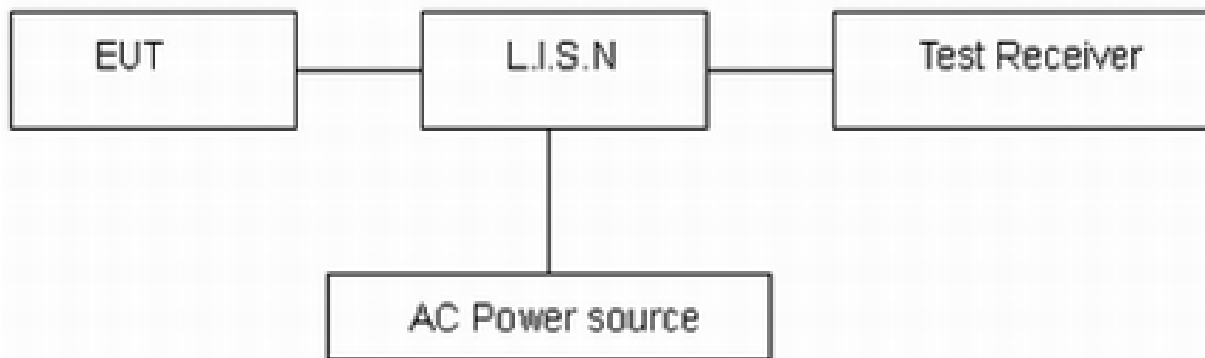

Note: AC Power source is used to 120V/60Hz.

Limits

Frequency (MHz)	Conducted Limits(dBμV)	
	Quasi-peak	Average
0.15 - 0.5	66 to 56 *	56 to 46*
0.5 - 5	56	46
5 - 30	60	50

*: Decreases with the logarithm of the frequency.

Measurement Uncertainty

The assessed measurement uncertainty to ensure 95% confidence level for the normal distribution is with the coverage factor $k = 1.96$, $U=2.69$ dB.

Test Results:

Following plots, Blue trace uses the peak detection, Green trace uses the average detection. During the test, the Conducted Emission was performed in all modes with all channels, BT 8DPSK 3DH5-Channel 78, are selected as the worst condition. The test data of the worst-case condition was recorded in this report.

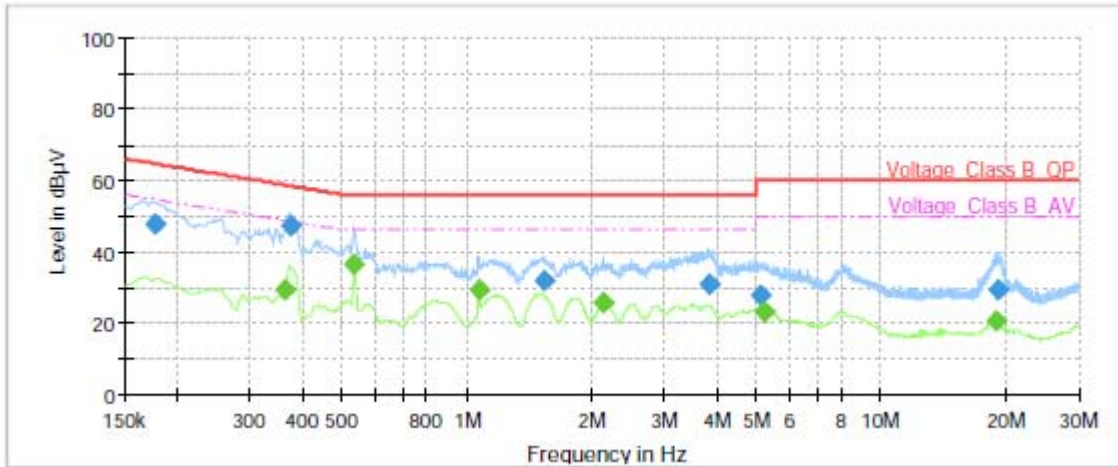

Frequency (MHz)	QuasiPeak (dBµV)	Average (dBµV)	Limit (dBµV)	Margin (dB)	Meas. Time (ms)	Bandwidth (kHz)	Line	Filter	Corr. (dB)
0.177000	47.47	---	64.63	17.16	1000.0	9.000	L1	ON	20.7
0.361500	---	29.19	48.69	19.51	1000.0	9.000	L1	ON	20.5
0.377250	47.07	---	58.34	11.27	1000.0	9.000	L1	ON	20.5
0.534750	---	36.44	46.00	9.56	1000.0	9.000	L1	ON	20.3
1.070250	---	28.98	46.00	17.02	1000.0	9.000	L1	ON	19.9
1.529250	31.82	---	56.00	24.18	1000.0	9.000	L1	ON	19.6
2.139000	---	25.76	46.00	20.24	1000.0	9.000	L1	ON	19.5
3.840000	30.71	---	56.00	25.29	1000.0	9.000	L1	ON	19.4
5.136000	27.84	---	60.00	32.16	1000.0	9.000	L1	ON	19.5
5.212500	---	22.99	50.00	27.01	1000.0	9.000	L1	ON	19.5
19.023000	---	20.54	50.00	29.46	1000.0	9.000	L1	ON	19.8
19.205250	29.20	---	60.00	30.80	1000.0	9.000	L1	ON	19.8

Remark: Correct factor=cable loss + LISN factor

L line

Conducted Emission from 150 KHz to 30 MHz

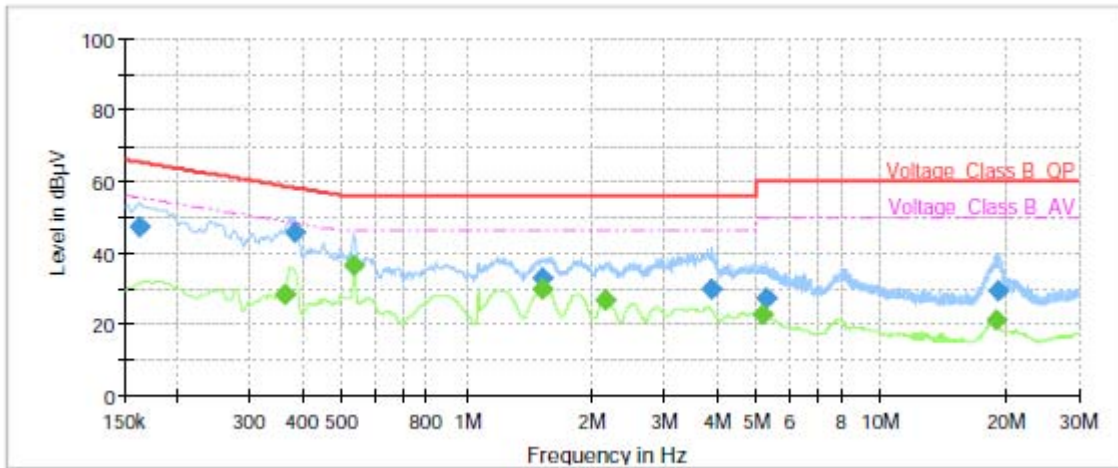

Frequency (MHz)	QuasiPeak (dBµV)	Average (dBµV)	Limit (dBµV)	Margin (dB)	Meas. Time (ms)	Bandwidth (kHz)	Line	Filter	Corr. (dB)
0.161250	47.34	---	65.40	18.06	1000.0	9.000	N	ON	20.8
0.361500	---	28.05	48.69	20.64	1000.0	9.000	N	ON	20.5
0.381750	45.39	---	58.24	12.85	1000.0	9.000	N	ON	20.5
0.534750	---	36.46	46.00	9.54	1000.0	9.000	N	ON	20.3
1.515750	32.66	---	56.00	23.34	1000.0	9.000	N	ON	19.7
1.518000	---	29.64	46.00	16.36	1000.0	9.000	N	ON	19.7
2.166000	---	26.90	46.00	19.10	1000.0	9.000	N	ON	19.5
3.907500	29.63	---	56.00	26.37	1000.0	9.000	N	ON	19.5
5.149500	---	22.40	50.00	27.60	1000.0	9.000	N	ON	19.5
5.284500	26.98	---	60.00	33.02	1000.0	9.000	N	ON	19.5
18.858750	---	21.17	50.00	28.83	1000.0	9.000	N	ON	19.8
19.074750	29.23	---	60.00	30.77	1000.0	9.000	N	ON	19.8

Remark: Correct factor=cable loss + LISN factor

N line Conducted Emission from 150 KHz to 30 MHz

6 Main Test Instruments

Name	Manufacturer	Type	Serial Number	Calibration Date	Expiration Date
Artificial main network	R&S	ENV216	102191	2020-12-13	2022-12-12
				2022-12-13	2024-12-09
EMI Test Receiver	R&S	ESR	101667	2022-05-25	2023-05-24
Software	R&S	EMC32	10.35.10	/	/
EMI Test Receiver	R&S	ESR	102389	2022-05-25	2023-05-24
Spectrum Analyzer	R&S	FSV40	101186	2022-05-14	2023-05-13
Loop Antenna	SCHWARZBECK	FMZB1519	1519-047	2021-12-12	2022-12-11
				2022-12-10	2023-12-09
TRILOG Broadband Antenna	SCHWARZBECK	VULB 9163	1023	2020-05-05	2023-05-04
Horn Antenna	R&S	HF907	102723	2020-08-11	2023-08-10
Horn Antenna	ETS-Lindgren	3160-09	00102643	2021-10-10	2024-10-09
Software	R&S	EMC32	9.26.0	/	/

ANNEX A: The EUT Appearance

The EUT Appearance are submitted separately.

ANNEX B: Test Setup Photos

The Test Setup Photos are submitted separately.

***** END OF REPORT *****