



Testing Tomorrow's Technology

**Application
For**

Part 2, Subpart J, Paragraph 2.907 Equipment Authorization of Certification for an Intentional Radiator per Part 15, Subpart C, paragraphs 15.207, 15.209 and 15.247

And

**Innovation, Science, and Economic Development Canada
Certification Per
IC RSS-Gen General Requirements for Radio Apparatus
And
RSS-247 Digital Transmission Systems (DTSS), Frequency Hopping Systems
(FHSs) and License-Exempt Local Area Network (LE-LAN) Devices**

For the

PakSense, Inc.

Model Number: UWL02G

**FCC ID: WPEUWL02G
IC: 8031A-UWL02G**

**UST Project: 19-0170
Issue Date: May 21, 2019**

Total Pages: **54**

**3505 Francis Circle Alpharetta, GA 30004
PH: 770-740-0717 Fax: 770-740-1508
www.ustech-lab.com**



Testing Tomorrow's Technology

I certify that I am authorized to sign for the Test Agency and that all of the statements in this report and in the Exhibits attached hereto are true and correct to the best of my knowledge and belief:

US TECH (Agent Responsible For Test):

By: Alan Ghasiani

Name: 

Title: Compliance Engineer – President

Date: May 21, 2019



NVLAP LAB CODE 200162-0

This report shall not be reproduced except in full. This report may be copied in part only with the prior written approval of US Tech. The results contained in this report are subject to the adequacy and representative character of the sample provided. This report must not be used to claim product certification, approval, or endorsement by NVLAP, NIST or any agency of the Federal Government.

3505 Francis Circle Alpharetta, GA 30004
PH : 770-740-0717 Fax : 770-740-1508
www.ustech-lab.com

US Tech Test Report:
FCC ID:
IC:
Test Report Number:
Issue Date:
Customer:
Model:

FCC Part 15/IC RSS Certification
WPEUWL02G
8031A-UWL02G
19-0170
May 21, 2019
PakSense, Inc.
UWL02G

MEASUREMENT TECHNICAL REPORT

COMPANY NAME: PakSense, Inc.
MODEL: UWL02G
FCC ID: WPEUWL02G
IC: 8031A-UWL02G
DATE: May 21, 2019

This report concerns (check one): Original grant
Class II change

Equipment type: 900 MHz Transmitter Module

Deferred grant requested per 47 CFR 0.457(d)(1)(ii)? Yes _____ No X

If yes, defer until: N/A
date

agrees to notify the Commission by N/A
date

of the intended date of announcement of the product so that the grant can be issued on that date.

Report prepared by:

US Tech
3505 Francis Circle
Alpharetta, GA 30004

Phone Number: (770) 740-0717
Fax Number: (770) 740-1508

Table of Contents

<u>Paragraph Title</u>	<u>Page</u>
1 General Information	7
1.1 Purpose of this Report	7
1.2 Characterization of Test Sample.....	7
1.3 Product Description	7
1.4 Configuration of Tested System.....	8
1.5 Test Facility.....	8
1.6 Related Submittal(s)/Grant(s)	8
2 Tests and Measurements.....	10
2.1 Test Equipment.....	10
2.2 Modifications to EUT Hardware	10
2.3 Number of Measurements for Intentional Radiators (CFR 15.31(m), RSS-Gen 6.8)	11
2.4 Frequency Range of Radiated Measurements (CFR 15.33, RSS-Gen 6.13)	11
2.4.1 Intentional Radiator.....	11
2.4.2 Unintentional Radiator	11
2.5 Measurement Detector Function and Bandwidth (CFR 15.35, RSS-Gen 6.9, 6.13)	12
2.5.1 Detector Function and Associated Bandwidth	12
2.5.2 Corresponding Peak and Average Requirements.....	12
2.5.3 Pulsed Transmitter Averaging.....	12
2.6 Transmitter Duty Cycle (Part 15.35 (c), RSS-Gen 6.10)	12
2.7 Restricted Bands of Operation (Part 15.205, RSS-Gen 8.10).....	15
2.8 EUT Antenna Requirements (CFR 15.203, RSS-Gen 6.7)	15
2.9 Maximum Peak Conducted Output Power (CFR 15.247(b)(3), RSS-247 (5.4(d)))	16
2.10 Power Spectral Density (CFR 15.247(e), RSS-247 (5.2(b)))	17
2.11 Antenna Conducted Intentional and Spurious Emissions (CFR 15.209, 15.247(d)) (RSS-247 (5.5), RSS-Gen 8.9)	18
2.12 Intentional Radiator, Radiated Emissions (CFR 15.209, 15.247(d), RSS-247 (5.2),(5.5))	25
2.13 Band Edge Measurements – (CFR 15.247(d), RSS-Gen 8.10).....	28
2.14 Six (6) dB Bandwidth (CFR 15.247(a)(2), RSS-247 (5.2(a)))	31
2.15 99% Occupied Bandwidth (RSS-GEN (6.6)).....	35
2.16 Unintentional Radiator and Intentional Radiator Power Lines Conducted Emissions (CFR 15.107, 15.207, RSS-Gen 8.8)	36

US Tech Test Report:
FCC ID:
IC:
Test Report Number:
Issue Date:
Customer:
Model:

FCC Part 15/IC RSS Certification
WPEUWL02G
8031A-UWL02G
19-0170
May 21, 2019
PakSense, Inc.
UWL02G

2.17	Unintentional Radiator and Intentional Radiator, Radiated Emissions (CFR 15.109, 15.209, RSS-Gen 8.9)	36
2.18	Measurement Uncertainty	40
2.18.1	Conducted Emissions Measurement Uncertainty	40
2.18.2	Radiated Emissions Measurement Uncertainty	40
3	Test Result	40

List of Figures

<u>Figures</u>	<u>Title</u>	<u>Page</u>
Figure 1.	Block Diagram of Test Configuration	9
Figure 2.	Duty Cycle On Time.....	13
Figure 3.	Duty Cycle Off Time.....	14
Figure 4.	Conducted Spurious Emissions – Low Channel, 30 MHz – 1 GHz.....	19
Figure 5.	Conducted Spurious Emissions – Low Channel, 1 GHz - 10 GHz.....	20
Figure 6.	Conducted Spurious Emissions – Mid Channel, 30 MHz - 1 GHz	21
Figure 7.	Conducted Spurious Emissions – Mid Channel, 1 GHz - 10 GHz.....	22
Figure 8.	Conducted Spurious Emissions – High Channel, 30 MHz – 1 GHz	23
Figure 9.	Conducted Spurious Emissions – High Channel, 1 GHz - 10 GHz	24
Figure 10.	Band Edge Compliance – Low Channel Delta - Peak.....	29
Figure 11.	Band Edge Compliance – High Channel Delta - Peak.....	30
Figure 12.	6 dB Bandwidth Low Channel.....	32
Figure 13.	6 dB Bandwidth Mid Channel.....	33
Figure 14.	6 dB Bandwidth High Channel	34

US Tech Test Report:
FCC ID:
IC:
Test Report Number:
Issue Date:
Customer:
Model:

FCC Part 15/IC RSS Certification
WPEUWL02G
8031A-UWL02G
19-0170
May 21, 2019
PakSense, Inc.
UWL02G

List of Tables

<u>Table</u>	<u>Title</u>	<u>Page</u>
Table 1.	EUT and Peripherals.....	9
Table 2.	Test Instruments	10
Table 3.	Number of Test Frequencies for Intentional Radiators.....	11
Table 4.	Peak Antenna Conducted Output Power per Part 15.247 (b)(3)	16
Table 5.	Peak Power Spectral Density.....	17
Table 6.	Peak Radiated Fundamental & Harmonic Emissions (Wired Antenna).....	26
Table 7.	Average Radiated Fundamental & Harmonic Emissions	27
Table 8.	Six (6) dB Bandwidth	31
Table 9.	99% Occupied Bandwidth	35
Table 10.	Spurious Radiated Emissions (9 kHz – 30 MHz)	37
Table 11.	Spurious Radiated Emissions (30 MHz – 1 GHz)	38
Table 12.	Spurious Radiated Emissions (1 GHz – 10 GHz).....	39

List of Attachments

FCC Agency Agreement	External Photos
Application Forms	FCC to IC Cross Reference
Letter of Confidentiality	FCC Modular Approval Letter
Equipment Label(s)	IC Modular Approval Letter
Block Diagram(s)	IC Agency Agreement
Schematic(s)	Canadian Rep Letter
Test Configuration Photographs	
Internal Photographs	
Theory of Operation	
RF Exposure	
User's Manual	

US Tech Test Report:
FCC ID:
IC:
Test Report Number:
Issue Date:
Customer:
Model:

FCC Part 15/IC RSS Certification
WPEUWL02G
8031A-UWL02G
19-0170
May 21, 2019
PakSense, Inc.
UWL02G

1 General Information

1.1 Purpose of this Report

This report is prepared as a means of conveying test results and information concerning the suitability of this exact product for public distribution according to IC RSS-247 and FCC Rules and Regulations Part 15, Section 247.

1.2 Characterization of Test Sample

The sample used for testing was received by US Tech on April 17, 2019 in good operating condition.

1.3 Product Description

The Equipment under Test (EUT) is the PakSense, Inc. GO Wireless Logger Model UWL02G. It is a time and temperature data logger designed for commercial applications. The EUT also incorporates a 902-928 MHz transceiver for wireless communication with a base station unit.

US Tech Test Report:
FCC ID:
IC:
Test Report Number:
Issue Date:
Customer:
Model:

FCC Part 15/IC RSS Certification
WPEUWL02G
8031A-UWL02G
19-0170
May 21, 2019
PakSense, Inc.
UWL02G

1.4 Configuration of Tested System

The Test Sample was tested per *ANSI C63.10:2013, American National Standard of Procedures for Compliance Testing of Unlicensed Wireless Devices* for the intentional radiator aspect of the device and *ANSI C63.4:2014, Methods of Measurement of Low-Voltage Electrical and Electronic Equipment in the Range of 9 kHz to 40 GHz (2014)* for the unintentional radiator aspect of the device as well as FCC subpart B and Cof Part 15 and per FCC KDB Publication number 558074 v05r02 for Digital Transmission Systems Operating Under section 15.247.

Digital RF conducted and radiated verification emissions data (FCC 15.107 and 109) below 1 GHz were taken with the measuring receiver (or spectrum analyzer's) resolution bandwidth adjusted to 9 kHz and 120 kHz, respectively. All measurements performed above 1.0 GHz were made with a RBW of 1 MHz. All measurements are peak unless stated otherwise. The video filter associated with the spectrum analyzer was set to 3 times the RBW or as required per the standard throughout the evaluation process.

A list of EUT and Peripherals is found in Table 1 below. A block diagram of the tested system is shown in Figure 1. Test configuration photographs for spurious and fundamental emissions are provided in separate Appendices.

1.5 Test Facility

Testing was performed at US Tech's measurement facility at 3505 Francis Circle, Alpharetta, GA 30004. This site has been fully described and registered with the FCC. Its designation number is 186022. Additionally this site has also been fully described and submitted to Industry Canada (IC), and has been approved under file number 9900A-1.

1.6 Related Submittal(s)/Grant(s)

The EUT is subject to the following FCC Equipment Authorizations:

- a) Certification of the transmitter incorporated within the EUT, see test data presented herein.
- b) Verification as a digital device under Part 15 Subpart B.

US Tech Test Report:
 FCC ID:
 IC:
 Test Report Number:
 Issue Date:
 Customer:
 Model:

FCC Part 15/IC RSS Certification
 WPEUWL02G
 8031A-UWL02G
 19-0170
 May 21, 2019
 PakSense, Inc.
 UWL02G

Table 1. EUT and Peripherals

EUT MANUFACTURER	MODEL NUMBER	SERIAL NUMBER	FCC/IC ID	CABLES P/D
PakSense, Inc.	UWL02G	Engineering Sample	FCC ID: WPEUWL02G IC: 8031A-UWL02G	-
PERIPHERAL MANUFACTURER	MODEL NUMBER	SERIAL NUMBER	FCC/IC ID	CABLES P/D
CloudGate Emerson	CG0199	XJ29J5S1T2	FCC ID: QIPPLS8-X IC: 7830A-PLS8X	P U

S= Shielded, U= Unshielded, P= Power, D= Data

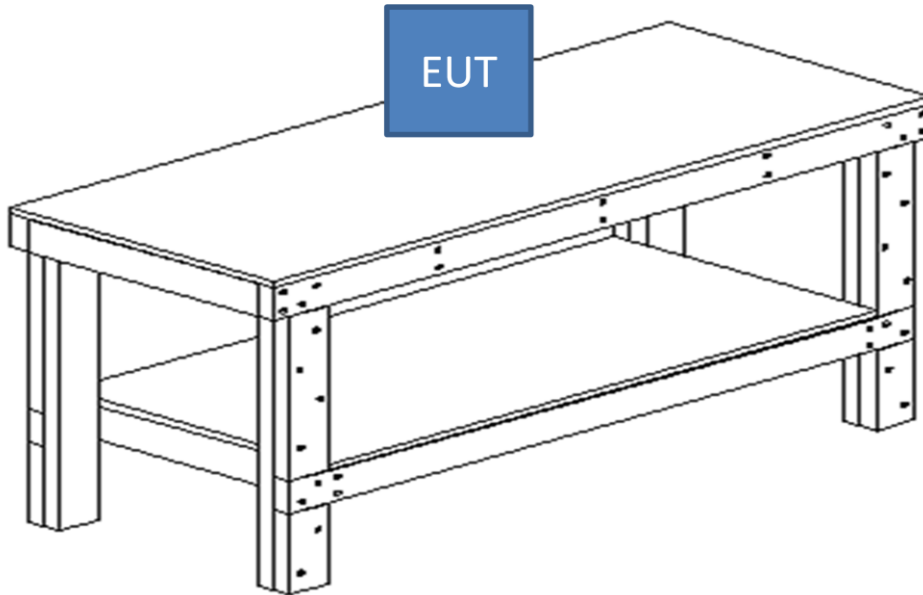

Figure 1. Block Diagram of Test Configuration

2 Tests and Measurements

2.1 Test Equipment

The table below lists test equipment used to evaluate this product.

Table 2. Test Instruments

TEST INSTRUMENT	MODEL NUMBER	MANUFACTURER	SERIAL NUMBER	CALIBRATION DUE DATE
SPECTRUM ANALYZER	E4407B	AGILENT	US41442935	8/17/2020
RF PREAMP 100 kHz to 1.3 GHz	8447D	HEWLETT-PACKARD	1937A02980	5/7/2020
PREAMP 1.0 GHz to 26.0 GHz	8449B	HEWLETT-PACKARD	3008A00480	4/8/2020
LOOP ANTENNA	SAS-200/562	A. H. Systems	142	1/22/2020 2 yr
BICONICAL ANTENNA	3110B	EMCO	9307-1431	10/23/2019
LOG PERIODIC ANTENNA	3146	EMCO	9305-3600	2/1/2021
HORN ANTENNA	3115	EMCO	9107-3723	11/28/2020 2 yr
HIGH PASS FILTER	VHF-1320 15542	MICROWAVE CIRCUITS	30843	6/08/2019 Extended

Note: The calibration interval of the above test instruments are 12 months unless stated otherwise and all calibrations are traceable to NIST/USA.

2.2 Modifications to EUT Hardware

No modifications were made by US Tech to bring the EUT into compliance with FCC Part 15.247 or IC RSS-210 requirements.

2.3 Number of Measurements for Intentional Radiators (CFR 15.31(m), RSS-Gen 6.8)

Measurements of intentional radiators or receivers shall be performed and reported for each band in which the device can be operated, with the device operating at the number of frequencies in each band specified in Table 3 as follows:

Table 3. Number of Test Frequencies for Intentional Radiators

Frequency Range over which the device operates	Number of Frequencies	Location in the Range of operation
1 MHz or less	1	Middle
1 to 10 MHz	2	1 near the top 1 near the bottom
Greater than 10 MHz	3	1 near top 1 near middle 1 near bottom

Because the EUT operates over 902.75 MHz to 927.25 MHz, 3 test frequencies will be used.

2.4 Frequency Range of Radiated Measurements (CFR 15.33, RSS-Gen 6.13)

2.4.1 Intentional Radiator

The spectrum shall be investigated for the intentional radiator from the lowest RF signal generated in the EUT, without going below 9 kHz to the 10th harmonic of the highest fundamental frequency generated or 40 GHz, whichever is the lowest.

2.4.2 Unintentional Radiator

For the digital device, an unintentional radiator, the frequency range shall be 30 MHz to 1000 MHz, or to the range specified in 2.4.1 above, whichever is the higher range of investigation.

2.5 Measurement Detector Function and Bandwidth (CFR 15.35, RSS-Gen 6.9, 6.13)

The radiated and conducted emissions limits shown herein are based on the parameters listed following.

2.5.1 Detector Function and Associated Bandwidth

On frequencies below 1000 MHz, the limits herein are based upon measurement equipment employing a CISPR Quasi-peak detector function and related measurement bandwidths (i.e. 9 kHz from 150 kHz to 30 MHz and 120 kHz from 30 MHz to 1000 MHz). Alternatively, measurements may be made with equipment employing a peak detector function as long as the same bandwidths specified for the Quasi-peak device are used.

2.5.2 Corresponding Peak and Average Requirements

Above 1000 MHz, radiated limits are based on measuring instrumentation employing an average detector function. When average radiated emissions are specified there is also a corresponding Peak requirement, as measured using a peak detector, of 20 dB greater than the average limit. For all measurements above 1000 MHz the Resolution Bandwidth shall be at least 1 MHz.

2.5.3 Pulsed Transmitter Averaging

When the radiated emissions limit is expressed as an average value, and the transmitter is pulsed, the measured field strength shall be determined by applying a Duty Cycle Correction Factor based upon dividing the total ON time during the first 100 ms period by 100 ms (or by the period if less than 100 ms). The duty cycle may also be expressed logarithmically in dB.

2.6 Transmitter Duty Cycle (Part15.35 (c), RSS-Gen 6.10)

The EUT employs pulse transmission however for testing purpose the EUT was programmed to transmit at a rate >98%. The pulse transmission requirements of this subpart were acknowledge and considered during testing.

When the radiated emissions limit is expressed as an average value, and the transmitter is pulsed, the measured field strength shall be determined by applying a Duty Cycle Correction Factor based upon dividing the total ON time during the first 100 ms period by 100 ms (or by the period if less than 100 ms). The duty cycle may also be expressed logarithmically in dB.

US Tech Test Report:
FCC ID:
IC:
Test Report Number:
Issue Date:
Customer:
Model:

FCC Part 15/IC RSS Certification
WPEUWL02G
8031A-UWL02G
19-0170
May 21, 2019
PakSense, Inc.
UWL02G

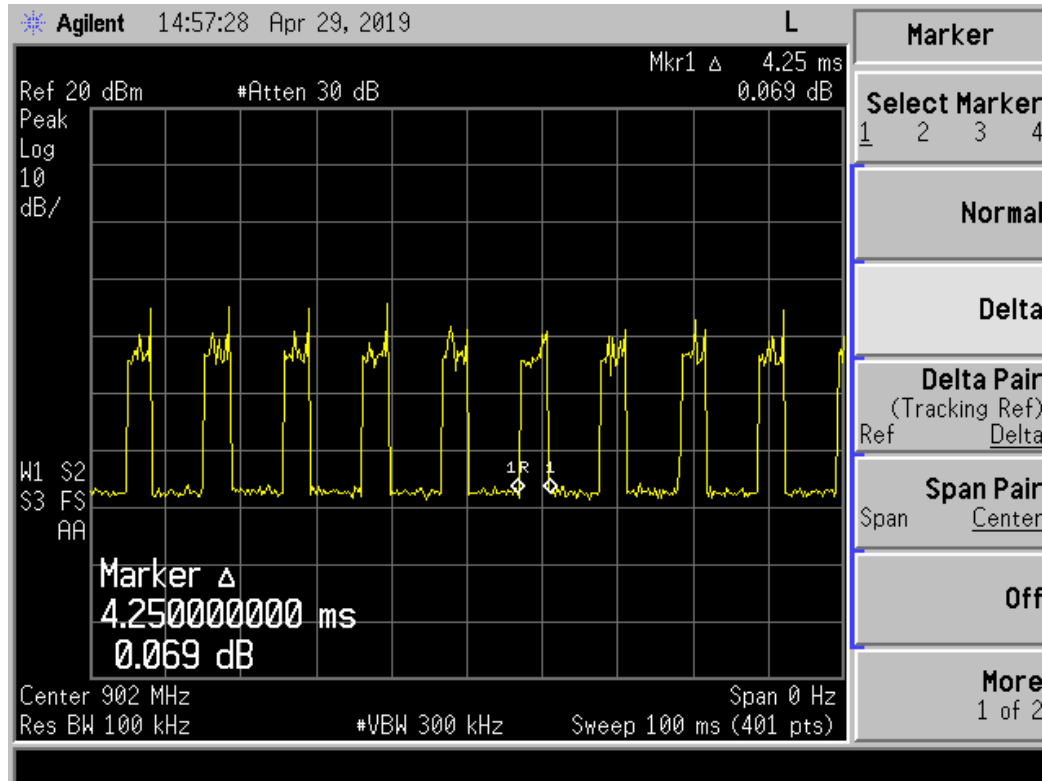

Figure 2. Duty Cycle On Time

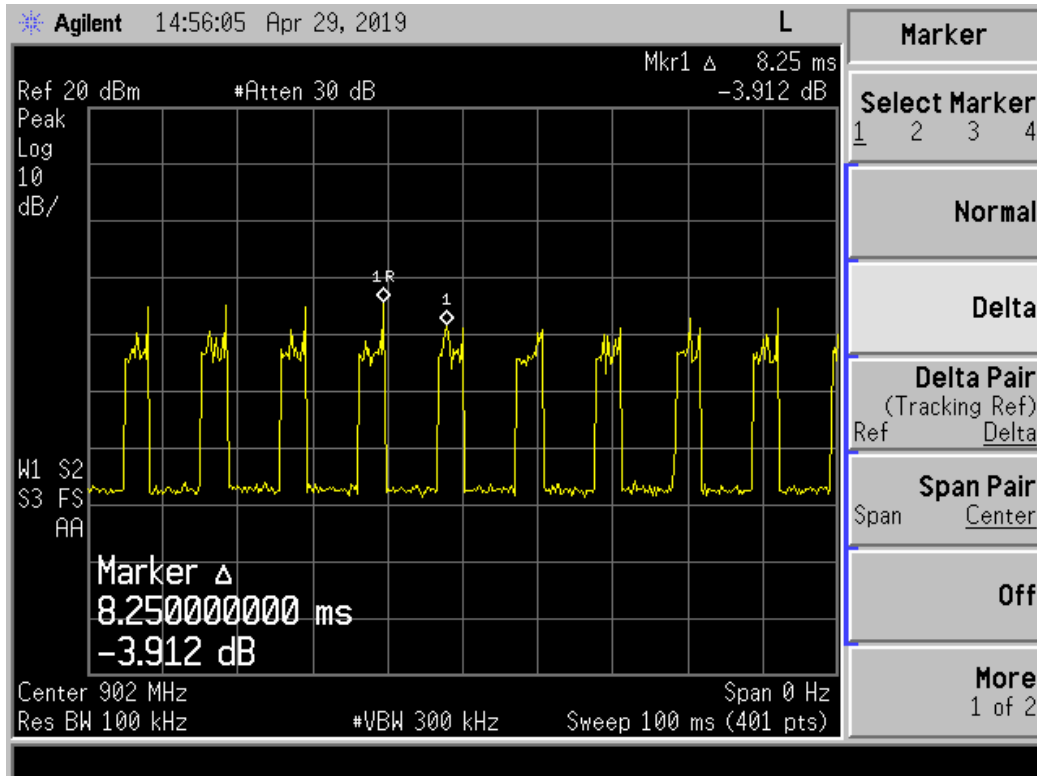

Figure 3. Duty Cycle Off Time

The duty cycle de-rating factor used in the calculation of average radiated limits per CFR 15.35(c) is described below. This factor was calculated by first determining the worst case scenario for system operation. With the worst case operating scenario the transmission duty cycle is calculated as:

- 4.25 mSec = ON time (Figure 2 above)
- 8.25 mSec = OFF time (Figure 3 above)

$$\text{Duty Cycle Factor} = \text{ON time} / (\text{ON time} + \text{OFF time}) = X$$

$$20 \text{ Log } (X) = \text{DC factor}$$

$$4.25 \text{ mSec} / (12.5 \text{ mSec}) = 0.34 \text{ or } 34\%$$

$$20 \text{ log } (.34) = -9.37 \text{ dB} = \text{DC factor}$$

US Tech Test Report:
FCC ID:
IC:
Test Report Number:
Issue Date:
Customer:
Model:

FCC Part 15/IC RSS Certification
WPEUWL02G
8031A-UWL02G
19-0170
May 21, 2019
PakSense, Inc.
UWL02G

2.7 Restricted Bands of Operation (Part 15.205, RSS-Gen 8.10)

Only spurious emissions can fall in the frequency bands of CFR 15.205. The field strength of these emissions cannot exceed the limits of 15.209. Radiated harmonics and other spurious emissions are examined for this requirement see paragraph 2.10.

2.8 EUT Antenna Requirements (CFR 15.203, RSS-Gen 6.7)

An intentional radiator shall be designed to ensure that no antenna other than that furnished by the responsible party shall be used with the device. The use of a permanently attached antenna or of an antenna that uses a unique coupling to the intentional radiator shall be considered sufficient to comply with the provisions of this section.

The EUT is designed for use with a PCB Trace antenna. The antenna gain is 0 dBi.

2.9 Maximum Peak Conducted Output Power (CFR 15.247(b)(3), RSS-247 (5.4(d)))

The EUT was programmed to operate at a normal operating output power across the bandwidth. For this test the normal operating output power of the radio was set to 2.6 dBm by default via the pre-loaded test firmware.

Peak power within the band 902.75 MHz to 927.25 MHz was measured per FCC KDB Publication 558074v05r02. Antenna-port conducted test could not be performed on the EUT therefore radiated test are used to show compliance to the conducted emissions requirement. The field strength level has been converted to the equivalent conducted power level using the EIRP formula found in ANSI C63.10-2013. The EUT transmit antenna gain was subtracted from the result. The final results are presented in the table below.

Table 4. Peak Antenna Conducted Output Power per Part 15.247 (b)(3)

Frequency of Fundamental (MHz)	P _{Cond}	(mW)	FCC Limit (mW Maximum)
902.75	6.81	4.80	1000
915.25	7.11	5.14	1000
927.25	6.02	4.00	1000

Sample calculation:

$$P_{\text{Cond}}/\text{EIRP} = (E_{\text{Meas}} + 20 \log (d_{\text{Meas}}) - 104.7) - G_{\text{EUT}}$$

Where:

P_{Cond}/EIRP is the calculated conducted output power after subtracting the antenna gain.

E_{Meas} is the field strength of the emission, dBuV/m (See Table 5 below)

d_{Meas} is the measurement distance, m

G_{EUT} is the gain of the EUT antenna in dBi

$$\text{EIRP} = (101.97 + 20 \cdot \log (3) - 104.7) - 0 = 6.81 \text{ dBm}$$

Test Date: May 7, 2019

Tested By

Signature: _____

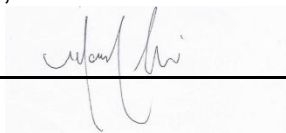

Name: Mark Afroози

US Tech Test Report:
FCC ID:
IC:
Test Report Number:
Issue Date:
Customer:
Model:

FCC Part 15/IC RSS Certification
WPEUWL02G
8031A-UWL02G
19-0170
May 21, 2019
PakSense, Inc.
UWL02G

2.10 Power Spectral Density (CFR 15.247(e), RSS-247 (5.2(b)))

For digitally modulated systems, the power spectral density conducted from the intentional radiator to the antenna shall not be greater than 8 dBm in any 3 kHz band during any time interval of continuous transmission. The same method of determining the conducted output power shall be used to determine the power spectral density.

Where measured peak conducted output power complies with the regulatory requirement for PSD, then measurement of PSD is not required.

In this case the peak conducted output power level of the transmitter falls below the +8 dB limit.

Table 5. Peak Power Spectral Density

Frequency of Fundamental (MHz)	PSD (dBm @100 kHz)	FCC Limit (dBm @3 kHz)	Margin
902.75	6.81	+8.0	1.19
915.25	7.11	+8.0	0.89
927.25	6.02	+8.0	1.98

Note: P_{Cond} from Table 4 used to show compliance to PSD limit per ANSI C63.10-2013, Clause 11.10.1

Test Date: May 7, 2019

Tested By

Signature: _____

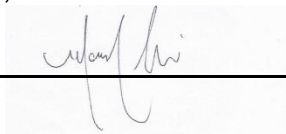

Name: Mark Afroози

US Tech Test Report:
FCC ID:
IC:
Test Report Number:
Issue Date:
Customer:
Model:

FCC Part 15/IC RSS Certification
WPEUWL02G
8031A-UWL02G
19-0170
May 21, 2019
PakSense, Inc.
UWL02G

2.11 Antenna Conducted Intentional and Spurious Emissions (CFR 15.209, 15.247(d)) (RSS-247 (5.5), RSS-Gen 8.9)

The EUT was put into a continuous-transmit mode of operation and tested per FCC KDB Publication 558074v05r02 for conducted out of band emissions radiating from the antenna port over the frequency range of 30 MHz to ten times the highest clock frequency generated or used in this case, 10 GHz. A conducted scan was performed on the EUT to identify and record spurious signals that were related to the transmitter. Antenna Conducted Emissions of a significant magnitude that fell within restricted bands were then measured as radiated emissions in the semi-anechoic chamber. The conducted emissions graphs are found in figures below. All spurious emissions must be at least 20 dB below the fundamental signal.

For Conducted RF antenna conducted tests, the RBW was set to 100 kHz, video bandwidth (VBW) > RBW, scan up through the 10th harmonic of the fundamental frequency. All harmonics/spurs must be at least 20 dB down from the highest emission level within the authorized band.

Note: In order to perform antenna-port conducted measurements an RF pigtail was soldered to PCB Trace antenna where the antenna-port connector would have been placed. Using this connection relative measurements were performed to show that spurious emissions from this feed-point to the antenna were meeting the limits.

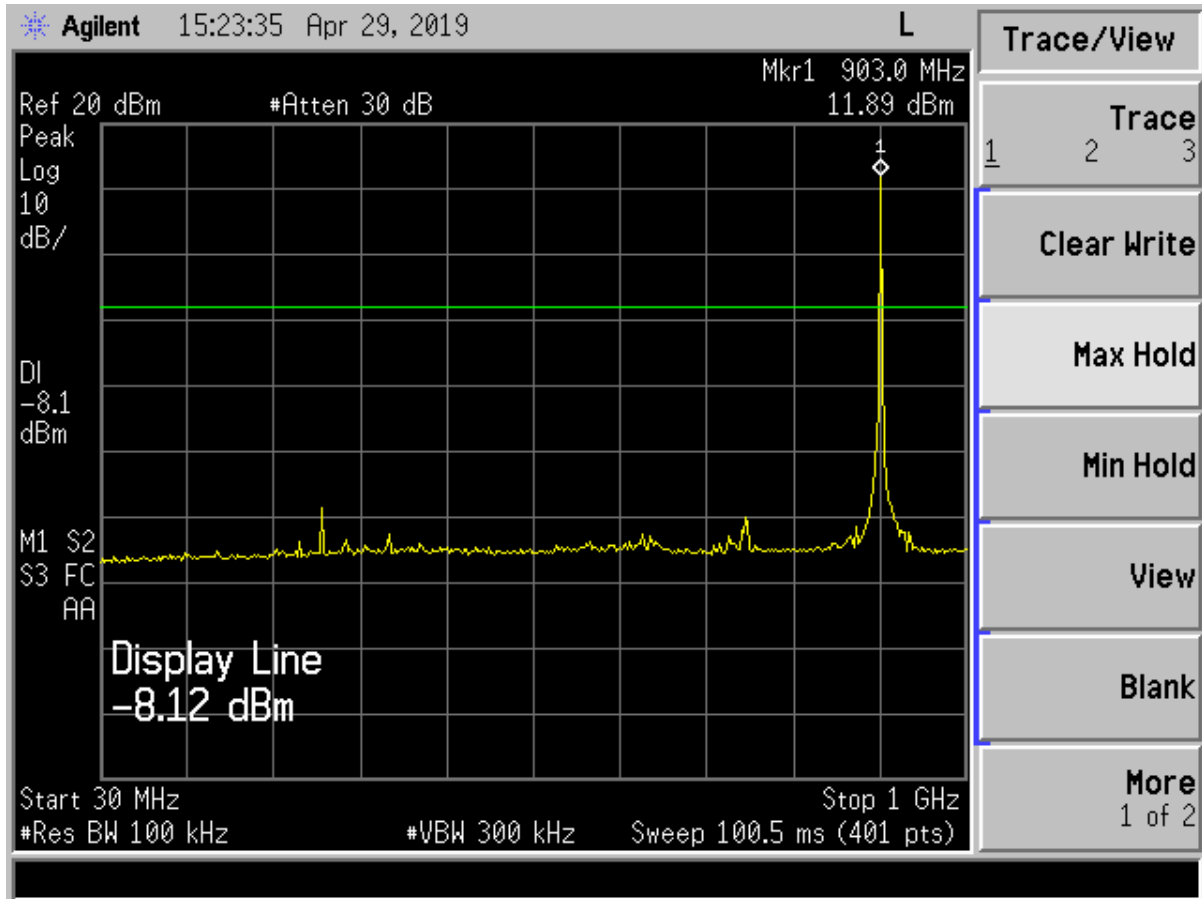

Figure 4. Conducted Spurious Emissions – Low Channel, 30 MHz – 1 GHz

Note: Large Signal shown is Fundamental Frequency

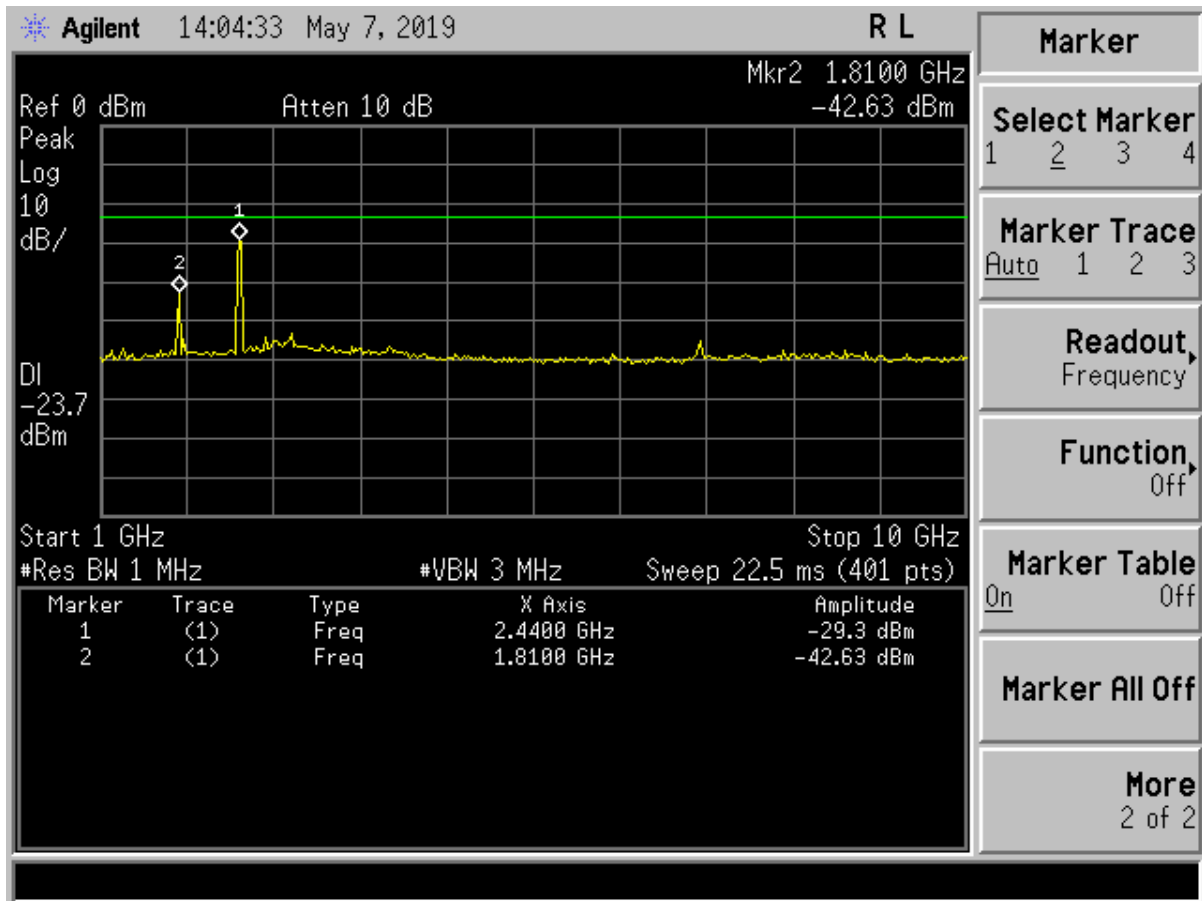

Figure 5. Conducted Spurious Emissions – Low Channel, 1 GHz - 10 GHz

Note: *Green display line represents 20 dB below fundamental frequency

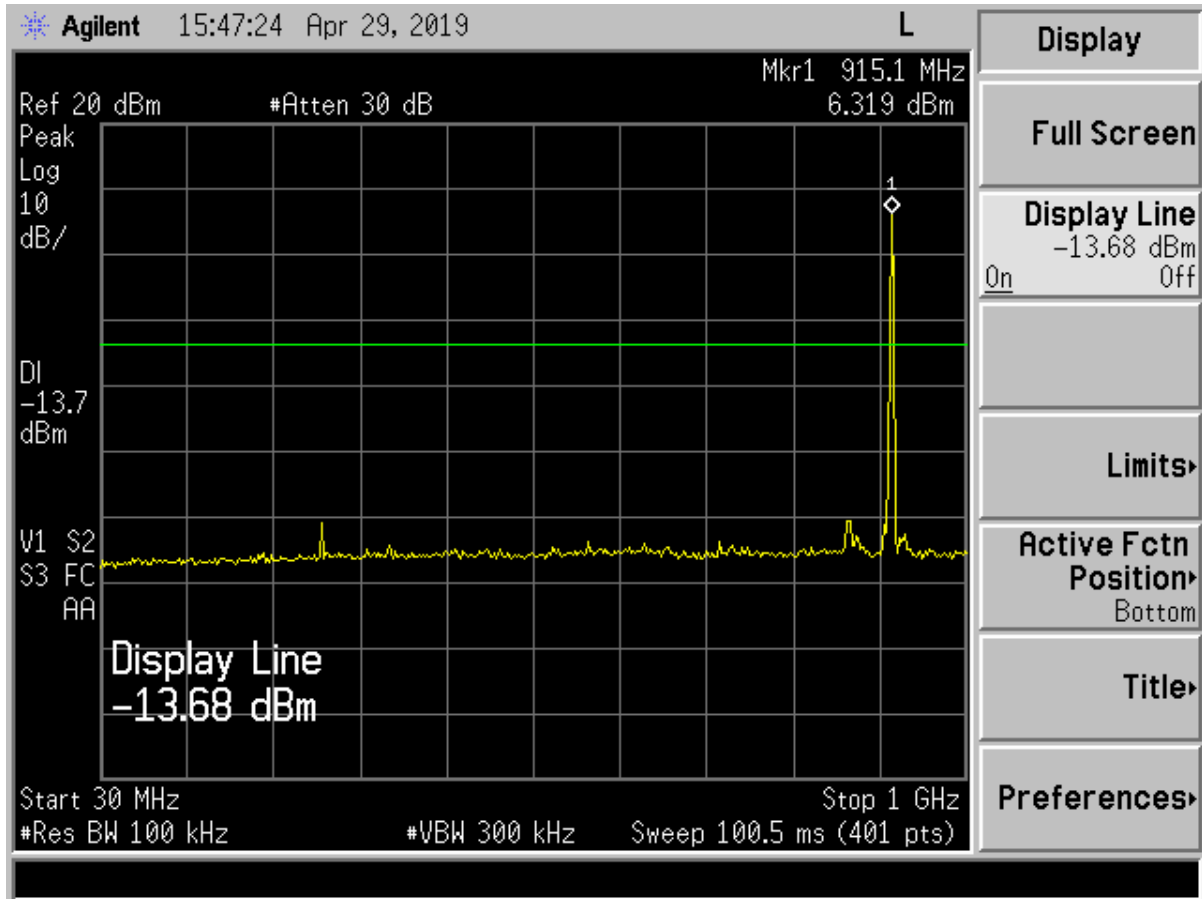

Figure 6. Conducted Spurious Emissions – Mid Channel, 30 MHz - 1 GHz

Note: *Large Signal shown is fundamental frequency.

*Green display line represents 20 dB below fundamental frequency.

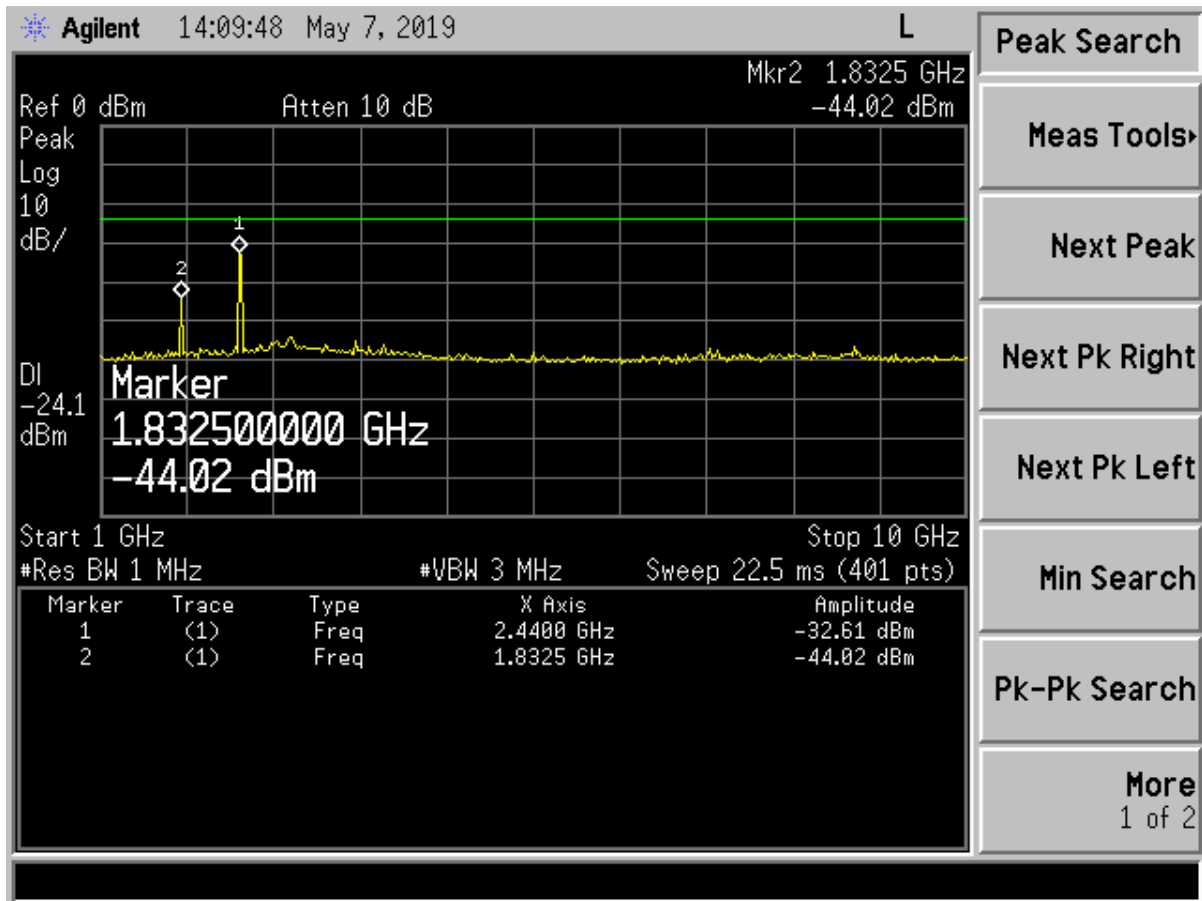

Figure 7. Conducted Spurious Emissions – Mid Channel, 1 GHz - 10 GHz

Note: *Green display line represents 20 dB below fundamental frequency

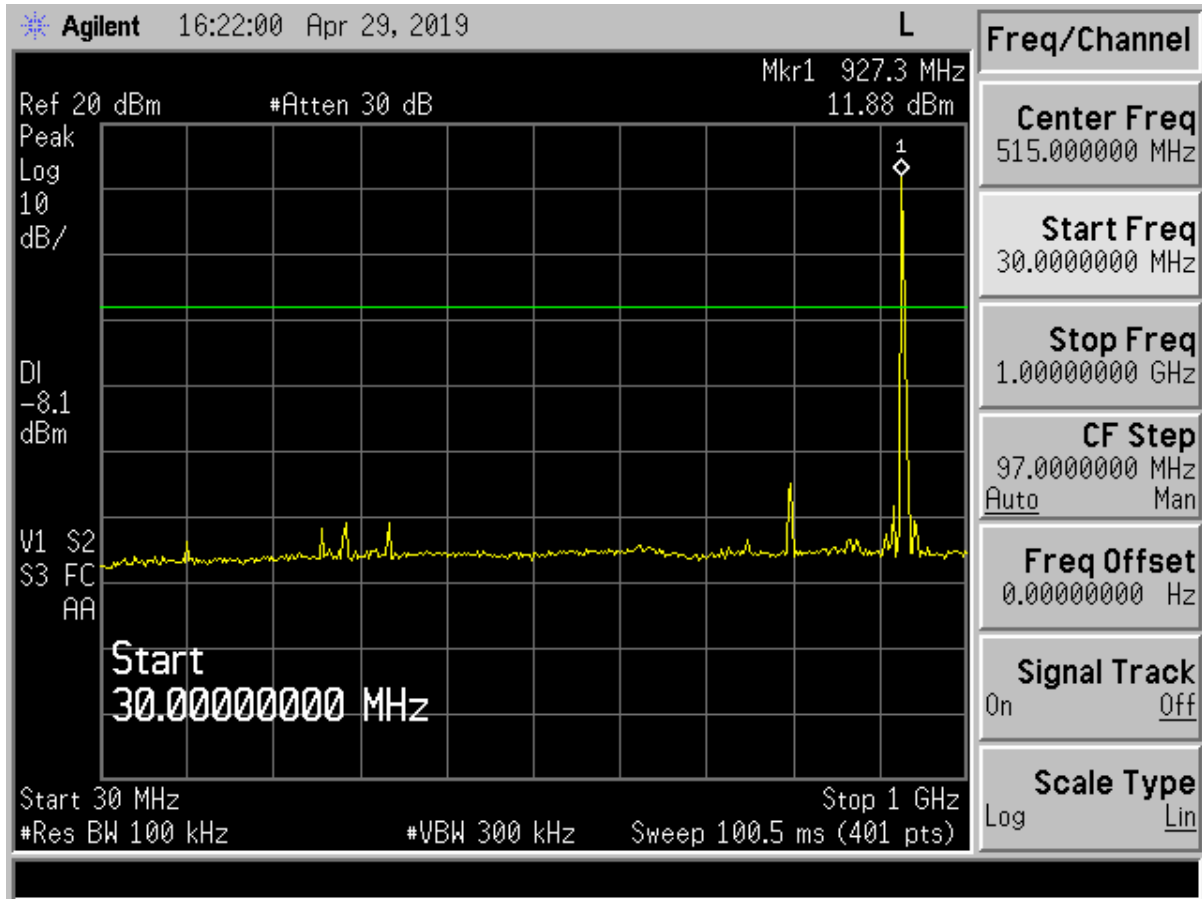

Figure 8. Conducted Spurious Emissions – High Channel, 30 MHz – 1 GHz

Note: *Large Signal shown is Fundamental Frequency
 *Green display line represents 20 dB below fundamental frequency

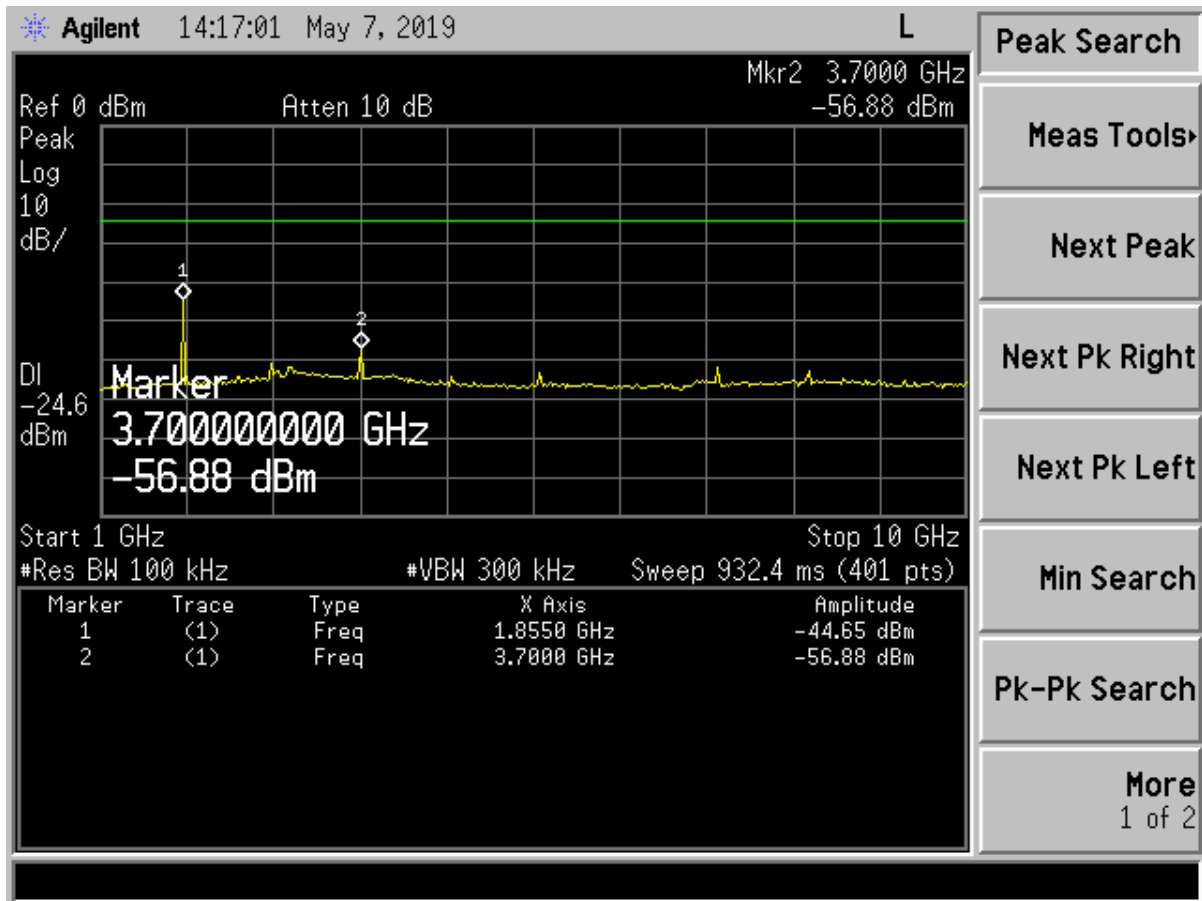

Figure 9. Conducted Spurious Emissions – High Channel, 1 GHz - 10 GHz

Note: *Green display line represents 20 dB below fundamental frequency

US Tech Test Report:
FCC ID:
IC:
Test Report Number:
Issue Date:
Customer:
Model:

FCC Part 15/IC RSS Certification
WPEUWL02G
8031A-UWL02G
19-0170
May 21, 2019
PakSense, Inc.
UWL02G

2.12 Intentional Radiator, Radiated Emissions (CFR 15.209, 15.247(d), RSS-247 (5.2),(5.5))

On the test site, the EUT was mounted on top of a non-conductive table, 80 cm above the floor, by placing it in the X-Z plane along the Z axis with its bottom cover in parallel with the ground. The front of the EUT faced the measurement antenna located 3 meters away. Each signal measured was maximized by raising and lowering the receive antenna between 1 and 4 meters in height while monitoring the ever changing spectrum analyzer display (with channel A in the Clear-Write mode and channel B in the Max-Hold mode) for the largest signal visible. That exact antenna height where the signal was maximized was recorded for reproducibility purposes. Also, the EUT was rotated about its Y-axis while monitoring the Spectrum Analyzer display for maximum. The EUT azimuth was recorded for reproducibility purposes. The EUT was measured when both maxima were simultaneously satisfied.

For radiated measurements, the EUT was set into a continuous transmission mode. Below 1 GHz, the RBW of the measuring instrument was set equal to 120 kHz. Peak measurements above 1 GHz were measured using a RBW = 1 MHz, with a VBW $\geq 3 \times$ RBW. The results of peak radiated spurious emissions falling within restricted bands are given in Table 5 below.

For Average measurements above 1 GHz, the emissions were measured using an average detector or the duty cycle correction factor was applied to the Peak recorded value.

US Tech Test Report:
 FCC ID:
 IC:
 Test Report Number:
 Issue Date:
 Customer:
 Model:

FCC Part 15/IC RSS Certification
 WPEUWL02G
 8031A-UWL02G
 19-0170
 May 21, 2019
 PakSense, Inc.
 UWL02G

Table 6. Peak Radiated Fundamental & Harmonic Emissions (Wired Antenna)

Frequency (MHz)	Test Data (dBuV)	Additional Factor	AF+CL-PA (dB/m)	Corrected Results (dBuV/m)	Limits (dBuV/m)	Distance / Polarization	Margin (dB)	Detector																
<table border="1" style="width:100%; border-collapse: collapse;"> <tr> <td style="width:15%;">Tested By: MA</td> <td style="width:35%;">Test: FCC Part 15,247(d)</td> <td colspan="6">Client: PakSense, Inc..</td> </tr> <tr> <td></td> <td>Project: 19-0170</td> <td colspan="6">Model: UWL02G</td> </tr> </table>									Tested By: MA	Test: FCC Part 15,247(d)	Client: PakSense, Inc..							Project: 19-0170	Model: UWL02G					
Tested By: MA	Test: FCC Part 15,247(d)	Client: PakSense, Inc..																						
	Project: 19-0170	Model: UWL02G																						
Low Channel																								
902.75	101.9	--	0.07	101.97	--	3.0m./HORZ	--	PK																
2708.25	51.22	--	-3.04	48.18	74.0	3.0m./VERT	25.8	PK																
3611	48.90	--	2.07	50.97	74.0	3.0m./VERT	23.0	PK																
4513.75	44.94	--	4.46	49.40	74.0	3.0m./VERT	24.6	PK																
5416.50	52.39		11.09	63.48	74.0	3.0m./VERT	10.5	PK																
8124.75	40.79		13.24	54.03	74.0	1.0m./HORZ	20.0	PK																
Middle Channel																								
915.25	102	--	0.27	102.27	--	3m./HORZ	--	PK																
2745	51.38	--	-3.19	48.19	74.0	3.0m./VERT	25.8	PK																
3661	48.85	--	3.19	52.04	74.0	3.0m./VERT	22.0	PK																
4576	43.67	--	3.12	46.79	74.0	3.0m./VERT	27.2	PK																
7322	46.43		12.96	58.36	74.0	1.0m./VERT	15.6	PK																
High Channel																								
927.25	101	--	0.18	101.18	--	3.0m./HORZ	--	PK																
2781.75	55.02	--	-3.03	51.99	74.0	3.0m./VERT	22.0	PK																
3709	52.23	--	3.84	56.07	74.0	3.0m./VERT	17.9	PK																
7418	52.43	--	11.43	63.86	74.0	1.0m./HORZ	10.1	PK																

1. No other signals detected within 20 dB of specification limit. Harmonics investigated up to the 10th harmonic

Sample Calculation at 2708.25 MHz:

Magnitude of Measured Frequency	51.22	dBuV
+Additional Factor	0.00	dB
+Antenna Factor + Cable Loss+ Amplifier Gain	-3.04	dB/m
Corrected Result	48.18	dBuV/m

Test Date: April 23, 2019

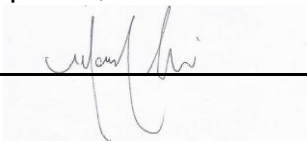
Tested By
 Signature: 

Name: Mark Afroozi

US Tech Test Report:
 FCC ID:
 IC:
 Test Report Number:
 Issue Date:
 Customer:
 Model:

FCC Part 15/IC RSS Certification
 WPEUWL02G
 8031A-UWL02G
 19-0170
 May 21, 2019
 PakSense, Inc.
 UWL02G

**Table 7. Average Radiated Fundamental & Harmonic Emissions
 (Wired Antenna)**

Tested By: MA		Test: FCC Part 15,247(d)			Client: PakSense, Inc..				
		Project: 19-0170			Model: UWL02G				
Frequency (MHz)	Test Data (dBuV)	Additional Factor	AF+CL-PA (dB/m)	Corrected Results (dBuV/m)	Limits (dBuV/m)	Distance / Polarization	Margin (dB)	Detector	
Low Channel									
902.75	92.53	--			--		--	AVG	
2708.25	34.24	--	-3.02	31.22	54.0	3.0m./HORZ	22.8	AVG	
3611	32.74	--	2.07	34.81	54.0	3.0m./VERT	19.2	AVG	
4513.75	29.66	--	4.46	34.12	54.0	3.0m./VERT	19.9	AVG	
5416.50	38.42	--	11.03	49.45	54.0	3.0m./HORZ	4.5	AVG	
8124.75	26.79	--	13.24	40.03	54.0	1.0m./HORZ	14.0	AVG	
Middle Channel									
915.25	92.63	--			--		--	AVG	
2745	35.05	--	-3.19	31.86	54.0	3.0m./VERT	22.1	AVG	
3661	32.69	--	3.19	35.88	54.0	3.0m./VERT	18.1	AVG	
4576	28.99	--	3.12	32.11	54.0	3.0m./VERT	21.9	AVG	
7322	29.48	--	12.87	42.35	54.0	1.0m./HORZ	11.6	AVG	
High Channel									
927.25	58.04	--			--	3m./HORZ	--	AVG	
2781.75	39.59	--	-3.03	36.56	54.0	3.0m./VERT	17.4	AVG	
3709	37.01	--	3.84	40.85	54.0	3.0m./VERT	13.2	AVG	
7418	37.59	--	11.43	49.02	54.0	1.0m./HORZ	5.0	AVG	

1. No other signals detected within 20 dB of specification limit. Harmonics investigated up to the 10th harmonic

Sample Calculation at 2708.25 MHz:

Magnitude of Measured Frequency	34.24	dBuV
+Additional Factor	0.00	dB
+Antenna Factor + Cable Loss+ Amplifier Gain	-3.02	dB/m
Corrected Result	31.22	dBuV/m

Test Date: April 23, 2019

Tested By

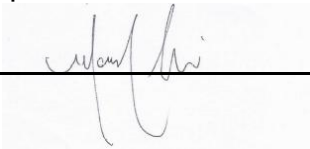
Signature: 

Name: Mark Afroozi

US Tech Test Report:
FCC ID:
IC:
Test Report Number:
Issue Date:
Customer:
Model:

FCC Part 15/IC RSS Certification
WPEUWL02G
8031A-UWL02G
19-0170
May 21, 2019
PakSense, Inc.
UWL02G

2.13 Band Edge Measurements – (CFR 15.247(d), RSS-Gen 8.10)

Band Edge measurements are made following the guidelines in FCC KDB Publication No. 558074 v05r02 with the EUT initially operating on the Lowest Channel and then operating on the Highest Channel within its band of operation. Antenna port conducted measurements are performed to demonstrate compliance with the requirement of 15.247(d) that all emissions outside of the band edges be attenuated by at least 20 dB when compared to its highest in-band value (contained in a 100 kHz band).

To capture the band edge set the Spectrum Analyzer frequency span large enough (usually around 10 MHz) to capture the peak level of the emission operating on the channel closest to the band edge as well as any modulation products falling outside of the authorized band of operation. Conducted measurements are performed with RBW $\geq 1\%$ of the frequency span. In all cases, the VBW is set $\geq 3 \times$ RBW. See figures and calculations below for more detail.

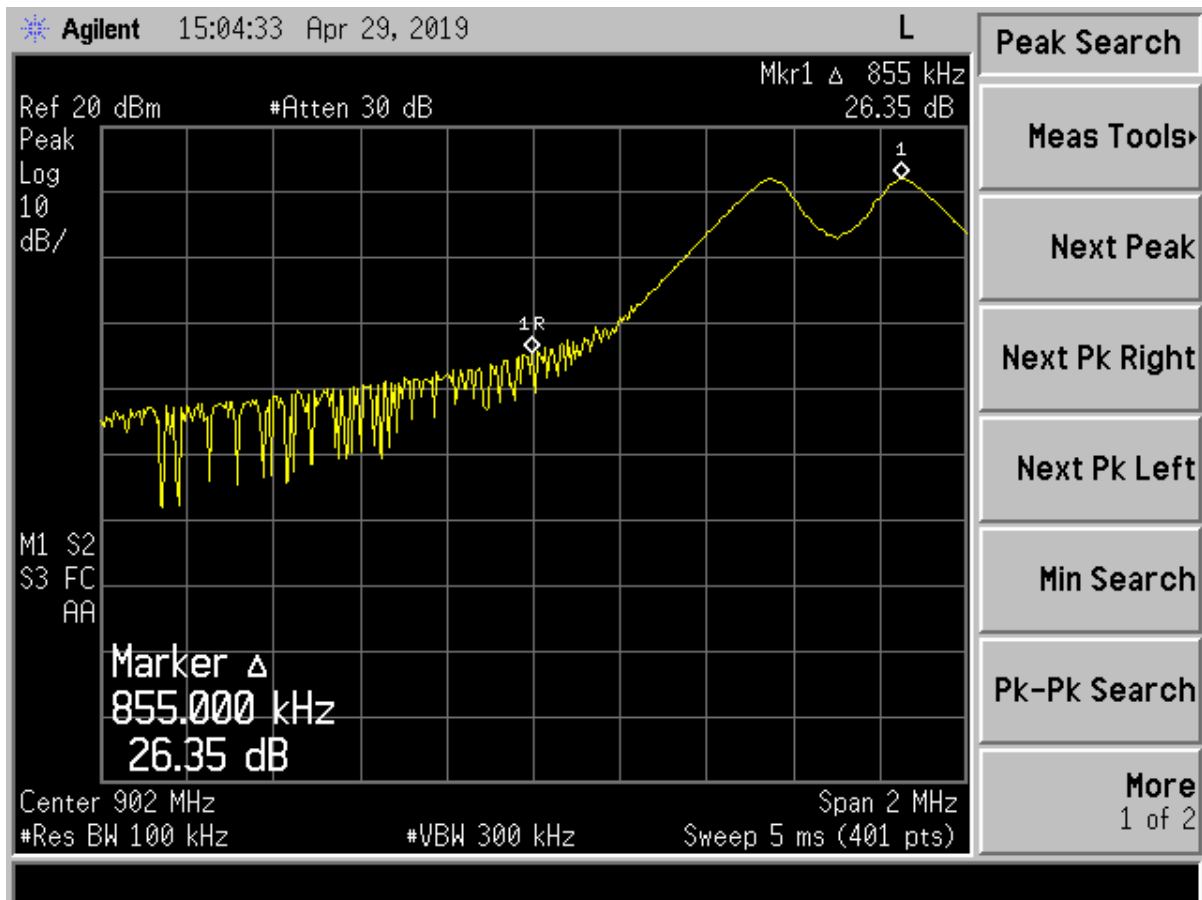

Figure 10. Band Edge Compliance – Low Channel Delta - Peak

Lower band edge must be 20 dB below the fundamental. This requirement is met.

Measured Result	26.35	dB
Band Edge Limit	20.00	dB
Band Edge Margin	6.35	dB

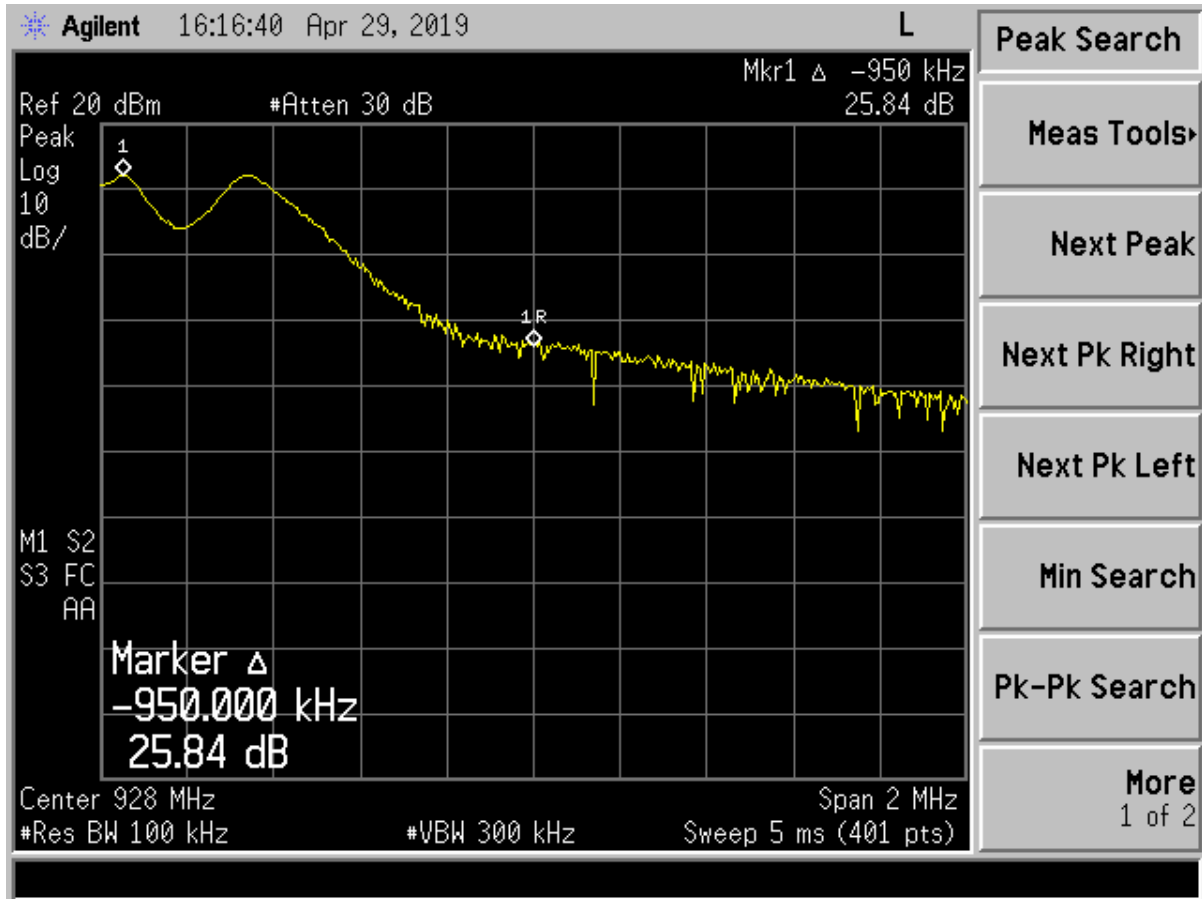

Figure 11. Band Edge Compliance – High Channel Delta - Peak

Higher band edge must be 20 dB below the fundamental. This requirement is met.

Measured Result	25.84	dB
Band Edge Limit	20.00	dB
Band Edge Margin	5.84	dB

US Tech Test Report:
FCC ID:
IC:
Test Report Number:
Issue Date:
Customer:
Model:

FCC Part 15/IC RSS Certification
WPEUWL02G
8031A-UWL02G
19-0170
May 21, 2019
PakSense, Inc.
UWL02G

2.14 Six (6) dB Bandwidth (CFR 15.247(a)(2), RSS-247 (5.2(a)))

The EUT antenna port was connected to a spectrum analyzer having a 50 Ω input impedance. Measurements were performed similar to the method of FCC, KDB Publication No. 558074 v05r02 for a bandwidth of 6 dB. The RBW was set to approximately 1/100 of the manufacturers claimed RBW and with the VBW \geq RBW. The results of this test are given in the table below and figures below.

Table 8. Six (6) dB Bandwidth

Frequency (MHz)	6 dB Bandwidth (MHz)	Minimum FCC Bandwidth (MHz)
902.75	0.8710	0.5
915.25	0.8643	0.5
927.25	0.8802	0.5

Test Date: April 29, 2019

Tested By

Signature: _____

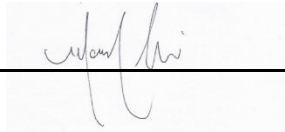

Name: Mark Afroози

US Tech Test Report:
 FCC ID:
 IC:
 Test Report Number:
 Issue Date:
 Customer:
 Model:

FCC Part 15/IC RSS Certification
 WPEUWL02G
 8031A-UWL02G
 19-0170
 May 21, 2019
 PakSense, Inc.
 UWL02G

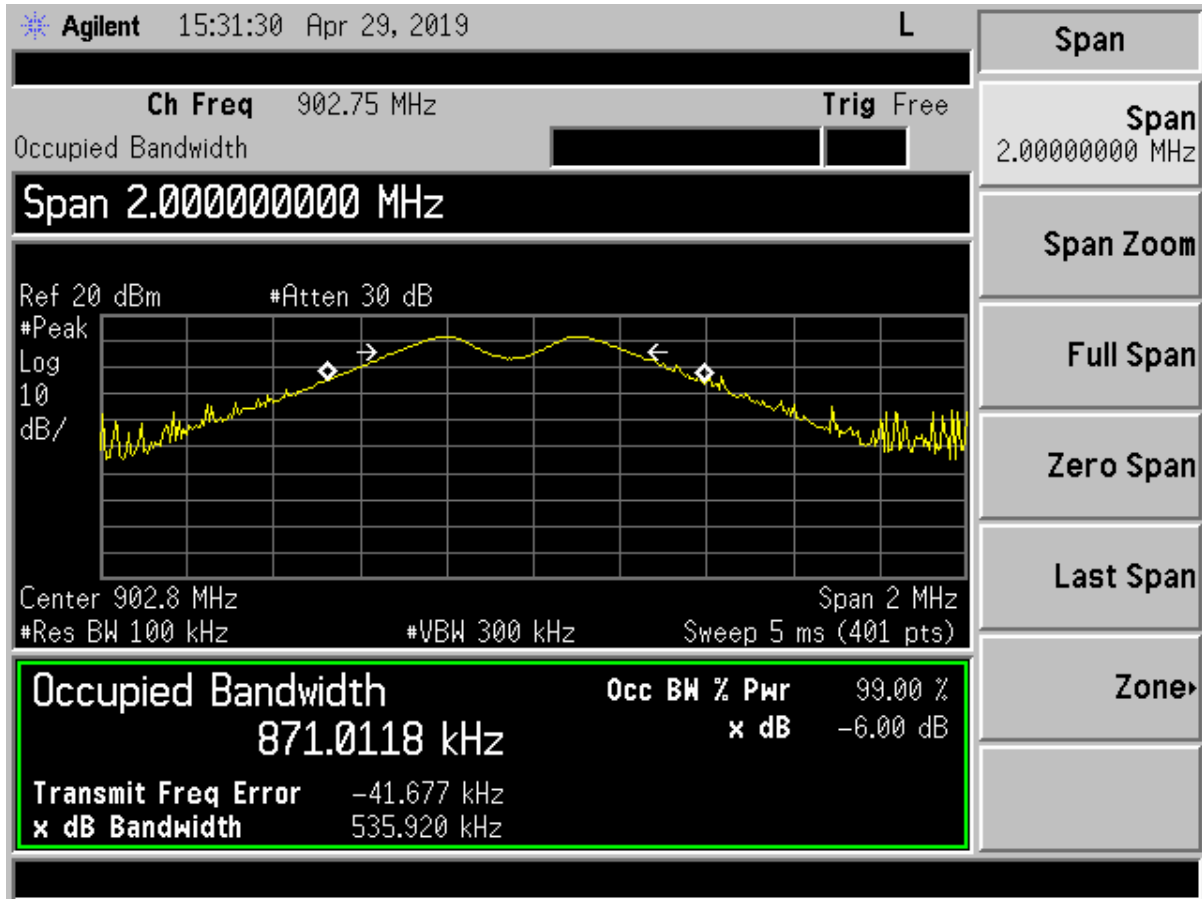

Figure 12. 6 dB Bandwidth Low Channel

US Tech Test Report:
 FCC ID:
 IC:
 Test Report Number:
 Issue Date:
 Customer:
 Model:

FCC Part 15/IC RSS Certification
 WPEUWL02G
 8031A-UWL02G
 19-0170
 May 21, 2019
 PakSense, Inc.
 UWL02G

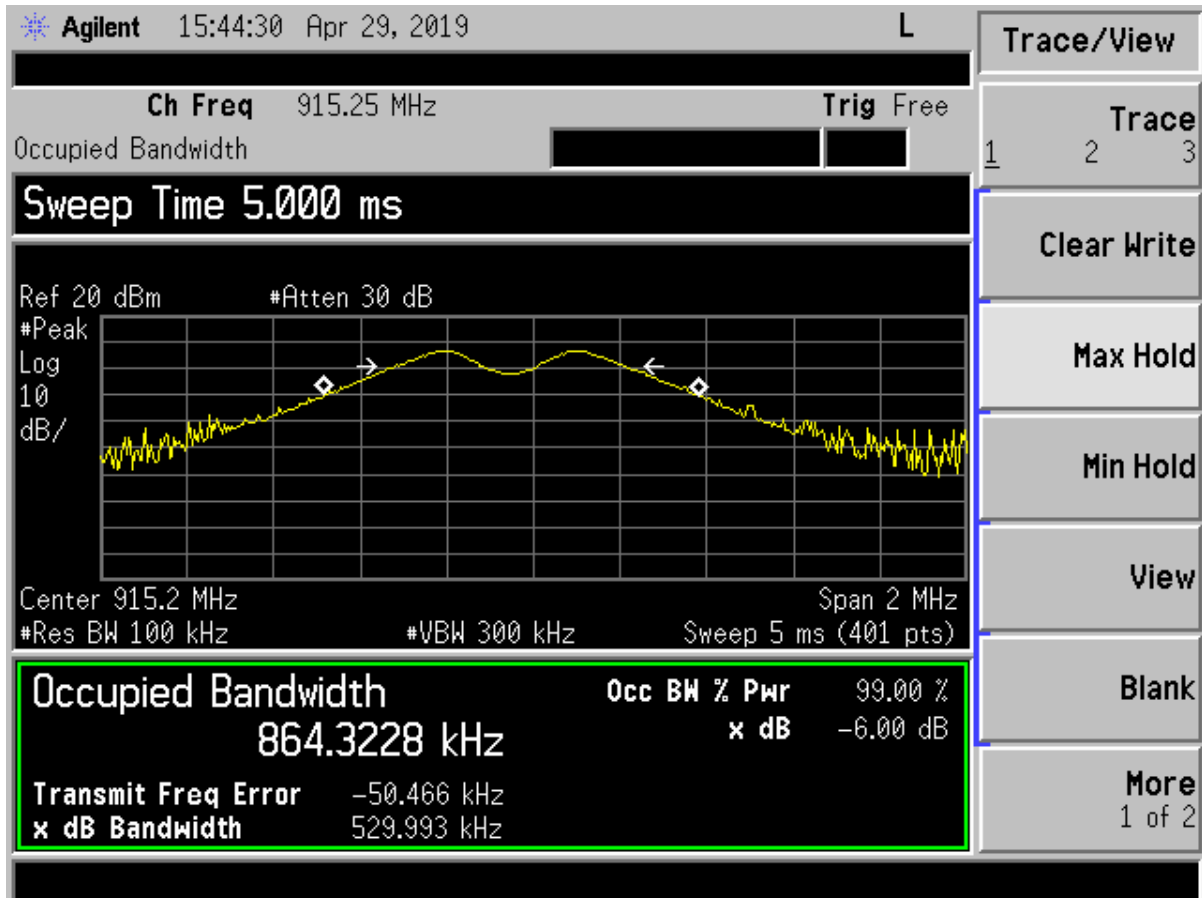

Figure 13. 6 dB Bandwidth Mid Channel

US Tech Test Report:
 FCC ID:
 IC:
 Test Report Number:
 Issue Date:
 Customer:
 Model:

FCC Part 15/IC RSS Certification
 WPEUWL02G
 8031A-UWL02G
 19-0170
 May 21, 2019
 PakSense, Inc.
 UWL02G

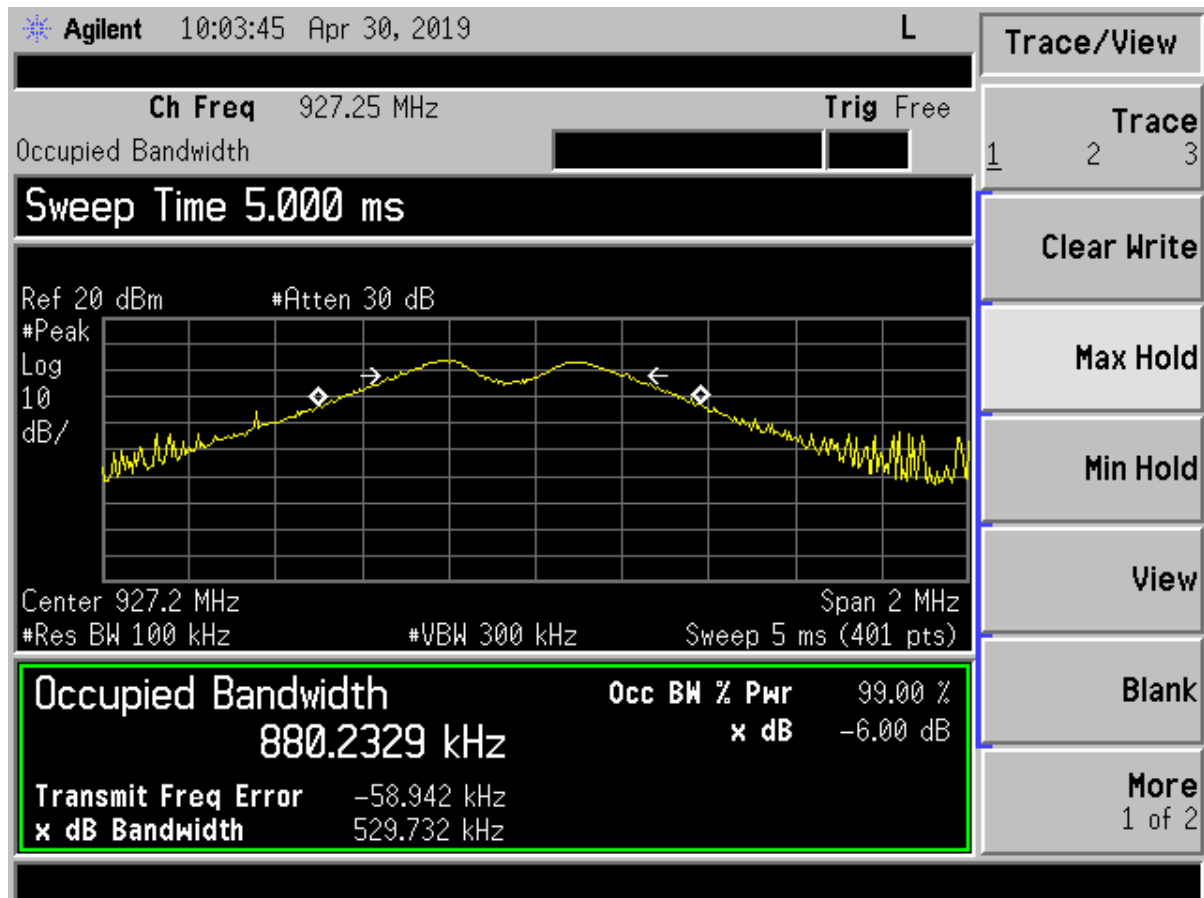

Figure 14. 6 dB Bandwidth High Channel

US Tech Test Report:
FCC ID:
IC:
Test Report Number:
Issue Date:
Customer:
Model:

FCC Part 15/IC RSS Certification
WPEUWL02G
8031A-UWL02G
19-0170
May 21, 2019
PakSense, Inc.
UWL02G

2.15 99% Occupied Bandwidth (RSS-GEN (6.6))

The EUT antenna port was connected to a spectrum analyzer having a 50Ω input impedance. Measurements were performed similar to the method of FCC, KDB Publication No. 558074 v05r02 for a bandwidth of 20 dB. The RBW was set to approximately 1/100 of the manufacturers claimed RBW and with the VBW ≥ RBW. The results of this test are given in the table below and figures below.

Table 9. 99% Occupied Bandwidth

Frequency (MHz)	(99%) Occupied Bandwidth (MHz)
902.75	1.0299
915.25	0.8755
927.25	0.8751

Test Date: April 29, 2019

Tested By

Signature:  Name: Mark Afroozi

US Tech Test Report:
FCC ID:
IC:
Test Report Number:
Issue Date:
Customer:
Model:

FCC Part 15/IC RSS Certification
WPEUWL02G
8031A-UWL02G
19-0170
May 21, 2019
PakSense, Inc.
UWL02G

2.16 Unintentional Radiator and Intentional Radiator Power Lines Conducted Emissions (CFR 15.107, 15.207, RSS-Gen 8.8)

EUT is battery powered; therefore, power lines conducted emissions is not applicable.

2.17 Unintentional Radiator and Intentional Radiator, Radiated Emissions (CFR 15.109, 15.209, RSS-Gen 8.9)

The test data provided herein is to support the verification requirement for radiated emissions coming from the EUT in a transmitting state per 15.209 and were investigated from 9kHz or the lowest operating clock frequency to 10 GHz and tested as detailed in ANSI C63.10:2013, Clause 6.4-6.6. Data is presented in the table below.

Radiated emissions within the band of 9 kHz to 30 MHz were investigated using a calibrated Loop Antenna and per the requirements of ANSI C63.10:2013.

Measurements were made with the analyzer's resolution bandwidth set to 120 kHz for measurements made below 1 GHz and 1 MHz for measurements made above 1 GHz. The video bandwidth was set to three times the resolution bandwidth; 1 MHz RBW and 3 MHz VBW. The test data were maximized for magnitude by rotating the turn-table through 360 degrees and raising and lowering the receiving antenna between 1 to 4 meters in height as a part of the measurement procedure.

The measurements were taken of the EUT transmitting at 902.75 MHz, 915.25 MHz and 927.25 MHz. For this test the output power of the radio was set to normal operating power of 2.6 dBm.

No emissions were seen greater than ambient noise-floor levels beside intentional emissions from the fundamental and harmonics.

US Tech Test Report:
 FCC ID:
 IC:
 Test Report Number:
 Issue Date:
 Customer:
 Model:

FCC Part 15/IC RSS Certification
 WPEUWL02G
 8031A-UWL02G
 19-0170
 May 21, 2019
 PakSense, Inc.
 UWL02G

Table 10. Spurious Radiated Emissions (9 kHz – 30 MHz)

Tested By: MA	Test: FCC Part 15,247(d)			Client: PakSense, Inc..				
	Project: 19-0170			Model: UWL02G				
Frequency (MHz)	Test Data (dBuV)	Additional Factor	AF+CL-PA (dB/m)	Corrected Results (dBuV/m)	Limits (dBuV/m)	Distance / Polarization	Margin (dB)	Detector
All emissions were more than 20 dB below the applicable limit.								

Test Date: April 25, 2019

Tested By

Signature: 

Name: Mark Afroozi

US Tech Test Report:
 FCC ID:
 IC:
 Test Report Number:
 Issue Date:
 Customer:
 Model:

FCC Part 15/IC RSS Certification
 WPEUWL02G
 8031A-UWL02G
 19-0170
 May 21, 2019
 PakSense, Inc.
 UWL02G

Table 11. Spurious Radiated Emissions (30 MHz – 1 GHz)

Test By: M. Afroozi	Test: FCC Part 15.109/15.209				Client: PakSense, Inc.			
	Project: 19-0170				Model: UWL02G			
Frequency (MHz)	Test Data (dBuV)	Additional Factors	AF+CL-PA (dB)	Results (dBuV/m)	Limits (dBuV/m)	Distance / Polarization	Margin (dB)	DETECTOR PK / QP/AVG
All emissions were more than 20 dB below the applicable limit.								

Test Date: April 25, 2019

Tested By

Signature: 

Name: Mark Afroozi

US Tech Test Report:
 FCC ID:
 IC:
 Test Report Number:
 Issue Date:
 Customer:
 Model:

FCC Part 15/IC RSS Certification
 WPEUWL02G
 8031A-UWL02G
 19-0170
 May 21, 2019
 PakSense, Inc.
 UWL02G

Table 12. Spurious Radiated Emissions (1 GHz – 10 GHz)

Test By: M. Afroozi	Test: FCC Part 15.109/15.209				Client: PakSense, Inc.			
	Project: 19-0170				Model: UWL02G			
Frequency (MHz)	Test Data (dBuV)	Additional Factors	AF+CL-PA (dB)	Results (dBuV/m)	Limits (dBuV/m)	Distance / Polarization	Margin (dB)	DETECTOR PK / QP/AVG
All emissions were more than 20 dB below the applicable limit.								

Test Date: April 25, 2019

Tested By

Signature:

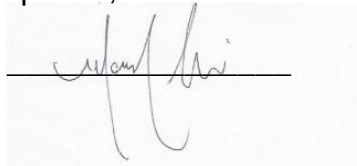

Name: Mark Afroozi

US Tech Test Report:
FCC ID:
IC:
Test Report Number:
Issue Date:
Customer:
Model:

FCC Part 15/IC RSS Certification
WPEUWL02G
8031A-UWL02G
19-0170
May 21, 2019
PakSense, Inc.
UWL02G

2.18 Measurement Uncertainty

The measurement uncertainties given were calculated using the method detailed in CISPR 16-4-2:2011. A coverage factor of $k=2$ was used to give a level of confidence of approximately 95%.

2.18.1 Conducted Emissions Measurement Uncertainty

Measurement Uncertainty (within a 95% confidence level) for this test is ± 2.78 dB.

2.18.2 Radiated Emissions Measurement Uncertainty

For a measurement distance of 3 m the measurement uncertainty (with a 95% confidence level) for this test using a Biconical Antenna (30 MHz to 200 MHz) is ± 5.3 dB. This value includes all elements of measurement.

The measurement uncertainty (with a 95% confidence level) for this test using a Log Periodic Antenna (200 MHz to 1000 MHz) is ± 5.1 dB.

The measurement uncertainty (with a 95% confidence level) for this test using a Horn Antenna is ± 5.1 dB.

3 Test Results

The EUT is deemed to have met the requirements of the standards cited within the test report when tested as detailed in the present test report.