



# FCC RF Test Report

**APPLICANT** : Maestro Wireless Holdings Limited  
**EQUIPMENT** : 3G WiFi Router  
**BRAND NAME** : Maestro  
**MODEL NAME** : E206XT  
**MARKETING NAME** : E206XT  
**FCC ID** : WN6-E206XT  
**STANDARD** : FCC Part 15 Subpart C §15.247  
**CLASSIFICATION** : (DTS) Digital Transmission System

The product was received on Mar. 17, 2015 and testing was completed on Apr. 16, 2015. We, SPORTON INTERNATIONAL (SHENZHEN) INC., would like to declare that the tested sample has been evaluated in accordance with the test procedures and has been in compliance with the applicable technical standards.

The test results in this report apply exclusively to the tested model / sample. Without written approval of SPORTON INTERNATIONAL (SHENZHEN) INC., the test report shall not be reproduced except in full.

Reviewed by: Joseph Lin / Supervisor

Approved by: Jones Tsai / Manager

**SPORTON INTERNATIONAL (SHENZHEN) INC.**

**1F & 2F, Building A, Morning Business Center, No. 4003 ShiGu Rd., Xili Town,  
Nanshan District, Shenzhen, Guangdong, P. R. China**





# TABLE OF CONTENTS

**REVISION HISTORY..... 3**

**SUMMARY OF TEST RESULT ..... 4**

**1 GENERAL DESCRIPTION ..... 5**

    1.1 Applicant ..... 5

    1.2 Manufacturer ..... 5

    1.3 Product Feature of Equipment Under Test ..... 5

    1.4 Product Specification subjective to this standard ..... 6

    1.5 Modification of EUT ..... 7

    1.6 Testing Location ..... 7

    1.7 Applicable Standards ..... 7

**2 TEST CONFIGURATION OF EQUIPMENT UNDER TEST ..... 8**

    2.1 Carrier Frequency Channel ..... 8

    2.2 Pre-Scanned RF Power ..... 9

    2.3 Test Mode ..... 10

    2.4 Connection Diagram of Test System ..... 10

    2.5 Support Unit used in test configuration and system ..... 11

    2.6 EUT Operation Test Setup ..... 11

    2.7 Measurement Results Explanation Example ..... 11

**3 TEST RESULT ..... 12**

    3.1 6dB and 99%Bandwidth Measurement ..... 12

    3.2 Output Power Measurement ..... 14

    3.3 Power Spectral Density Measurement ..... 16

    3.4 Conducted Band Edges and Spurious Emission Measurement ..... 18

    3.5 Radiated Band Edges and Spurious Emission Measurement ..... 31

    3.6 Antenna Requirements ..... 35

**4 LIST OF MEASURING EQUIPMENT ..... 36**

**5 UNCERTAINTY OF EVALUATION ..... 37**

**APPENDIX A. CONDUCTED TEST RESULTS**

**APPENDIX B. RADIATED TEST RESULTS**

**APPENDIX C. SETUP PHOTOGRAPHS**





### SUMMARY OF TEST RESULT

Report Section	FCC Rule	IC Rule	Description	Limit	Result	Remark
3.1	15.247(a)(2)	RSS-210 A8.2(a)	6dB Bandwidth	$\geq 0.5\text{MHz}$	Pass	-
3.1	-	RSS-Gen 4.6.1	99% Bandwidth	-	Pass	-
3.2	15.247(b)	RSS-210 A8.4	Power Output Measurement	$\leq 30\text{dBm}$	Pass	-
3.3	15.247(e)	RSS-210 A8.2(b)	Power Spectral Density	$\leq 8\text{dBm}/3\text{kHz}$	Pass	-
3.4	15.247(d)	RSS-210 A8.5	Conducted Band Edges	$\leq 20\text{dBc}$	Pass	-
			Conducted Spurious Emission		Pass	-
3.5	15.247(d)	RSS-210 A8.5	Radiated Band Edges and Radiated Spurious Emission	15.209(a) & 15.247(d)	Pass	Under limit 3.23 dB at 2484.880 MHz
3.6	15.203 & 15.247(b)	RSS-210 A8.4	Antenna Requirement	N/A	Pass	-



# 1 General Description

## 1.1 Applicant

**Maestro Wireless Holdings Limited**

FLAT A & B, 9/F, WING CHEONG FACTORY BUILDING, 121 KING LAM STREET, CHEUNG SHA WAN, HONG KONG

## 1.2 Manufacturer

**Maestro Wireless Holdings Limited**

FLAT A & B, 9/F, WING CHEONG FACTORY BUILDING, 121 KING LAM STREET, CHEUNG SHA WAN, HONG KONG

## 1.3 Product Feature of Equipment Under Test

Product Feature	
Equipment	3G WiFi Router
Brand Name	Maestro
Model Name	E206XT
Marketing Name	E206XT
FCC ID	WN6-E206XT
Integrated WWAN Module	Brand Name: AirPrime Model Name: SL9090
EUT supports Radios application	GPRS/EGPRS/WCDMA/HSPA/ WLAN2.4GHz 802.11b/g/n HT20/HT40
HW Version	V06
SW Version	V2.0
EUT Stage	Pre-Production

**Remark:** The above EUT's information was declared by manufacturer. Please refer to the specifications or user's manual for more detailed description.



### 1.4 Product Specification subjective to this standard

Product Specification subjective to this standard	
<b>Tx/Rx Channel Frequency Range</b>	802.11b/g/n : 2412 MHz ~ 2462 MHz
<b>Maximum (Peak) Output Power to Antenna</b>	802.11b : 16.92 dBm (0.0492 W) 802.11g : 23.35 dBm (0.2163 W) 802.11n HT20 : 22.21 dBm (0.1663 W) 802.11n HT40 : 19.99 dBm (0.0998 W)
<b>99% Occupied Bandwidth</b>	802.11b : 15.25MHz 802.11g : 17.60MHz 802.11n HT20 : 18.35MHz 802.11n HT40 : 36.40MHz
<b>Antenna Type / Gain</b>	802.11b/g/n : Dipole Antenna with gain 3.8 dBi
<b>Type of Modulation</b>	802.11b : DSSS (DBPSK / DQPSK / CCK) 802.11g/n : OFDM (BPSK / QPSK / 16QAM / 64QAM)



### 1.5 Modification of EUT

No modifications are made to the EUT during all test items.

### 1.6 Testing Location

<b>Test Site</b>	SPORTON INTERNATIONAL (SHENZHEN) INC.	
<b>Test Site Location</b>	1F & 2F, Building A, Morning Business Center, No. 4003 ShiGu Rd., Xili Town, Nanshan District, Shenzhen, Guangdong, P. R. China TEL: +86-755-8637-9589 FAX: +86-755-8637-9595	
<b>Test Site No.</b>	<b>Sporton Site No.</b>	
	TH01-SZ	

<b>Test Site</b>	SPORTON INTERNATIONAL (SHENZHEN) INC.	
<b>Test Site Location</b>	No. 3 Building, the third floor of south, Shahe River west, Fengzeyuan warehouse, Nanshan District, Shenzhen, Guangdong, P. R. China TEL: +86-755- 3320-2398	
<b>Test Site No.</b>	<b>Sporton Site No.</b>	<b>FCC/IC Registration No.</b>
	03CH01-SZ	831040/4086F-1

Note: The test site complies with ANSI C63.4 2009 requirement.

### 1.7 Applicable Standards

According to the specifications of the manufacturer, the EUT must comply with the requirements of the following standards:

- ♦ FCC Part 15 Subpart C §15.247
- ♦ FCC KDB Publication No. 558074 D01 DTS Meas. Guidance v03r02
- ♦ ANSI C63.10-2013
- ♦ IC RSS-210 Issue 8
- ♦ IC RSS-Gen Issue 4

**Remark:**

1. All test items were verified and recorded according to the standards and without any deviation during the test.
2. FCC permits the use of the 1.5 meter table as an alternative in C63.10-2013 through inquiry tracking number 961829.
3. This EUT has also been tested and complied with the requirements of FCC Part 15, Subpart B, recorded in a separate test report.



## 2 Test Configuration of Equipment Under Test

The EUT has been associated with peripherals and configuration operated in a manner tended to maximize its emission characteristics in a typical application. Frequency range investigated: conducted emission (150 kHz to 30 MHz) and radiated emission (9 kHz to the 10th harmonic of the highest fundamental frequency or to 40 GHz, whichever is lower). For radiated measurement, pre-scanned in three orthogonal panels, X, Y, Z. The data were recorded in this report.

The final configuration from all the combinations and the worst-case data rates were investigated by measuring the maximum power across all the data rates and modulation modes under section 2.2.

Based on the worst configuration found above, the RF power setting is set individually to meet FCC compliance limit for the final conducted and radiated tests shown in section 2.3.

### 2.1 Carrier Frequency Channel

Frequency Band	Channel	Freq. (MHz)	Channel	Freq. (MHz)
2400-2483.5 MHz	1	2412	7	2442
	2	2417	8	2447
	3	2422	9	2452
	4	2427	10	2457
	5	2432	11	2462
	6	2437	-	-





## 2.2 Pre-Scanned RF Power

Preliminary tests were performed in different data rate and data rate associated with the highest power were chosen for full test shown in the following tables.

2.4GHz 802.11b RF Output Power (dBm)						
Power vs. Channel			Power vs. Data Rate			
Channel	Frequency (MHz)	Data Rate	Channel	2Mbps	5.5Mbps	11Mbps
		1Mbps				
CH 01	2412 MHz	16.67	CH 11	16.82	16.88	16.86
CH 06	2437 MHz	16.79				
CH 11	2462 MHz	16.92				

2.4GHz 802.11g RF Output Power (dBm)										
Power vs. Channel			Power vs. Data Rate							
Channel	Frequency (MHz)	Data Rate	Channel	9Mbps	12Mbps	18Mbps	24Mbps	36Mbps	48Mbps	54Mbps
		6Mbps								
CH 01	2412 MHz	22.58	CH 11	22.94	22.97	22.59	23.21	22.71	23.13	22.96
CH 06	2437 MHz	23.12								
CH 11	2462 MHz	23.35								

2.4GHz 802.11n HT20 RF Output Power (dBm)										
Power vs. Channel			Power vs. MCS Index							
Channel	Frequency (MHz)	MCS Index	Channel	MCS1	MCS2	MCS3	MCS4	MCS5	MCS6	MCS7
		MCS0								
CH 01	2412 MHz	21.24	CH 11	22.18	22.06	22.17	22.14	22.07	22.08	21.96
CH 06	2437 MHz	21.71								
CH 11	2462 MHz	22.21								

2.4GHz 802.11n HT40 RF Output Power (dBm)										
Power vs. Channel			Power vs. MCS Index							
Channel	Frequency (MHz)	MCS Index	Channel	MCS1	MCS2	MCS3	MCS4	MCS5	MCS6	MCS7
		MCS0								
CH 03	2422 MHz	19.24	CH 09	19.92	19.39	19.64	19.57	19.96	19.71	18.73
CH 06	2437 MHz	19.86								
CH 09	2452 MHz	19.99								

## 2.3 Test Mode

Final test mode of conducted test items and radiated spurious emissions are considering the modulation and worse data rates from the power table described in section 2.2.

Modulation	Data Rate
802.11b	1 Mbps
802.11g	6 Mbps
802.11n HT20	MCS0
802.11n HT40	MCS0

## 2.4 Connection Diagram of Test System

<WLAN Tx Mode>

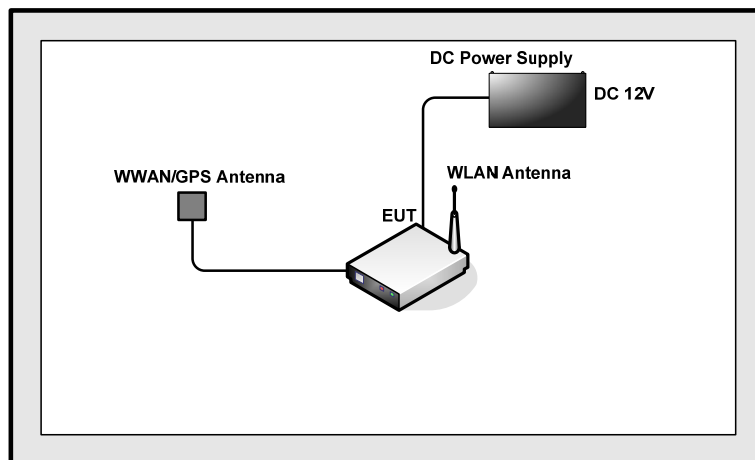



## 2.5 Support Unit used in test configuration and system

Item	Equipment	Trade Name	Model Name	FCC ID	Data Cable	Power Cord
1.	DC Power Supply	GWINSTEK	GPS-3030D	N/A	N/A	Unshielded, 1.8 m
2.	WLAN Antenna	N/A	N/A	N/A	N/A	N/A
3.	WWAN/GPS Antenna	N/A	N/A	N/A	N/A	N/A

## 2.6 EUT Operation Test Setup

For WLAN function, the engineering test program was provided and enabled to make EUT continuous transmit/receive.

## 2.7 Measurement Results Explanation Example

For all conducted test items:

The offset level is set in the spectrum analyzer to compensate the RF cable loss and attenuator factor between EUT conducted output port and spectrum analyzer. With the offset compensation, the spectrum analyzer reading level is exactly the EUT RF output level.

Example:

The spectrum analyzer offset is derived from RF cable loss and attenuator factor.

*Offset = RF cable loss + attenuator factor.*

Following shows an offset computation example with cable loss 5 dB and 10dB attenuator.

$$\begin{aligned} \text{Offset(dB)} &= \text{RF cable loss(dB)} + \text{attenuator factor(dB)}. \\ &= 5 + 10 = 15 \text{ (dB)} \end{aligned}$$

### 3 Test Result

#### 3.1 6dB and 99%Bandwidth Measurement

##### 3.1.1 Limit of 6dB and 99%Bandwidth

The minimum 6 dB bandwidth shall be at least 500 kHz.

##### 3.1.2 Measuring Instruments

The measuring equipment is listed in the section 4 of this test report.

##### 3.1.3 Test Procedures

1. The testing follows FCC KDB Publication No. 558074 DTS D01 Meas. Guidance v03r02.
2. The RF output of EUT was connected to the spectrum analyzer by RF cable and attenuator. The path loss was compensated to the results for each measurement.
3. Set to the maximum power setting and enable the EUT transmit continuously.
4. Make the measurement with the spectrum analyzer's resolution bandwidth (RBW) = 100 kHz. Set the Video bandwidth (VBW) = 300 kHz. In order to make an accurate measurement. The 6 dB bandwidth must be greater than 500 kHz.
5. For 99% Bandwidth Measurement, the spectrum analyzer's resolution bandwidth (RBW) = 1MHz and set the Video bandwidth (VBW) = 3MHz.
6. Measure and record the results in the test report.

##### 3.1.4 Test Setup





### 3.1.5 Test Result of 6dB and 99% Bandwidth

Please refer to Appendix A of this test report.

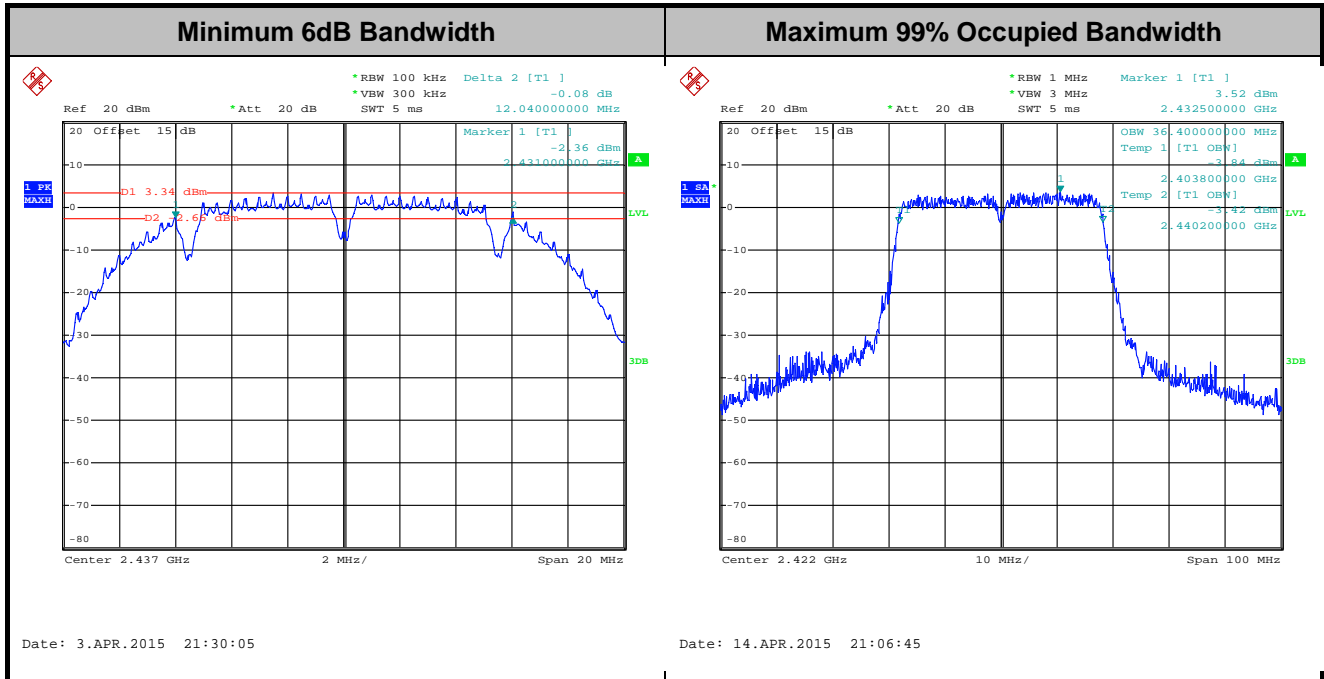

Note: The occupied channel bandwidth is maintained within the band of operation for all of the modulations.

## 3.2 Output Power Measurement

### 3.2.1 Limit of Output Power

For systems using digital modulation in the 2400-2483.5MHz, the limit for peak output power is 30dBm. If transmitting Antenna of directional gain greater than 6dBi are used the peak output power from the intentional radiator shall be reduced below the above stated value by the amount in dB that the directional gain of the Antenna exceeds 6 dBi. In case of point-to-point operation, the limit has to be reduced by 1dB for every 3dB that the directional gain of the Antenna exceeds 6dBi.

### 3.2.2 Measuring Instruments

The measuring equipment is listed in the section 4 of this test report.

### 3.2.3 Test Procedures

1. The testing follows the Measurement Procedure of FCC KDB No. 558074 DTS D01 Meas. Guidance v03r02.
2. The RF output of EUT was connected to the power meter by RF cable and attenuator. The path loss was compensated to the results for each measurement.
3. Set to the maximum power setting and enable the EUT transmit continuously.
4. Measure the conducted output power and record the results in the test report.

### 3.2.4 Test Setup

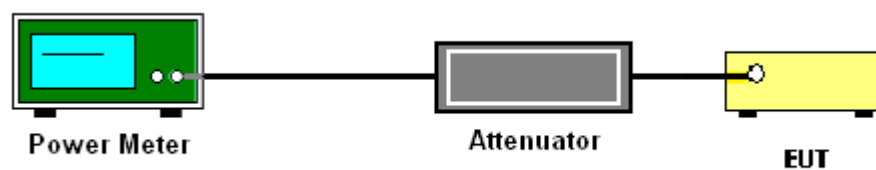



### **3.2.5 Test Result of Peak Output Power**

Please refer to Appendix A of this test report.

### **3.2.6 Test Result of Average output Power (Reporting Only)**

Please refer to Appendix A of this test report.

### 3.3 Power Spectral Density Measurement

#### 3.3.1 Limit of Power Spectral Density

The peak power spectral density shall not be greater than 8dBm in any 3kHz band at any time interval of continuous transmission.

#### 3.3.2 Measuring Instruments

The measuring equipment is listed in the section 4 of this test report.

#### 3.3.3 Test Procedures

1. The testing follows Measurement Procedure 10.2 Method PKPSD of FCC KDB Publication No. 558074 D01 DTS Meas. Guidance v03r02
2. The RF output of EUT was connected to the spectrum analyzer by RF cable and attenuator. The path loss was compensated to the results for each measurement.
3. Set to the maximum power setting and enable the EUT transmit continuously.
4. Make the measurement with the spectrum analyzer's resolution bandwidth (RBW) = 3 kHz. Video bandwidth VBW = 10 kHz In order to make an accurate measurement, set the span to 1.5 times DTS Channel Bandwidth. (6dB BW)
5. Detector = peak, Sweep time = auto couple, Trace mode = max hold, Allow trace to fully stabilize. Use the peak marker function to determine the maximum power level.
6. Measure and record the results in the test report.

#### 3.3.4 Test Setup

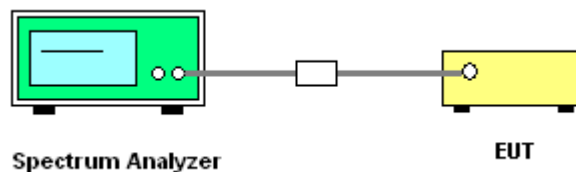





### 3.3.5 Test Result of Power Spectral Density

Please refer to Appendix A of this test report.

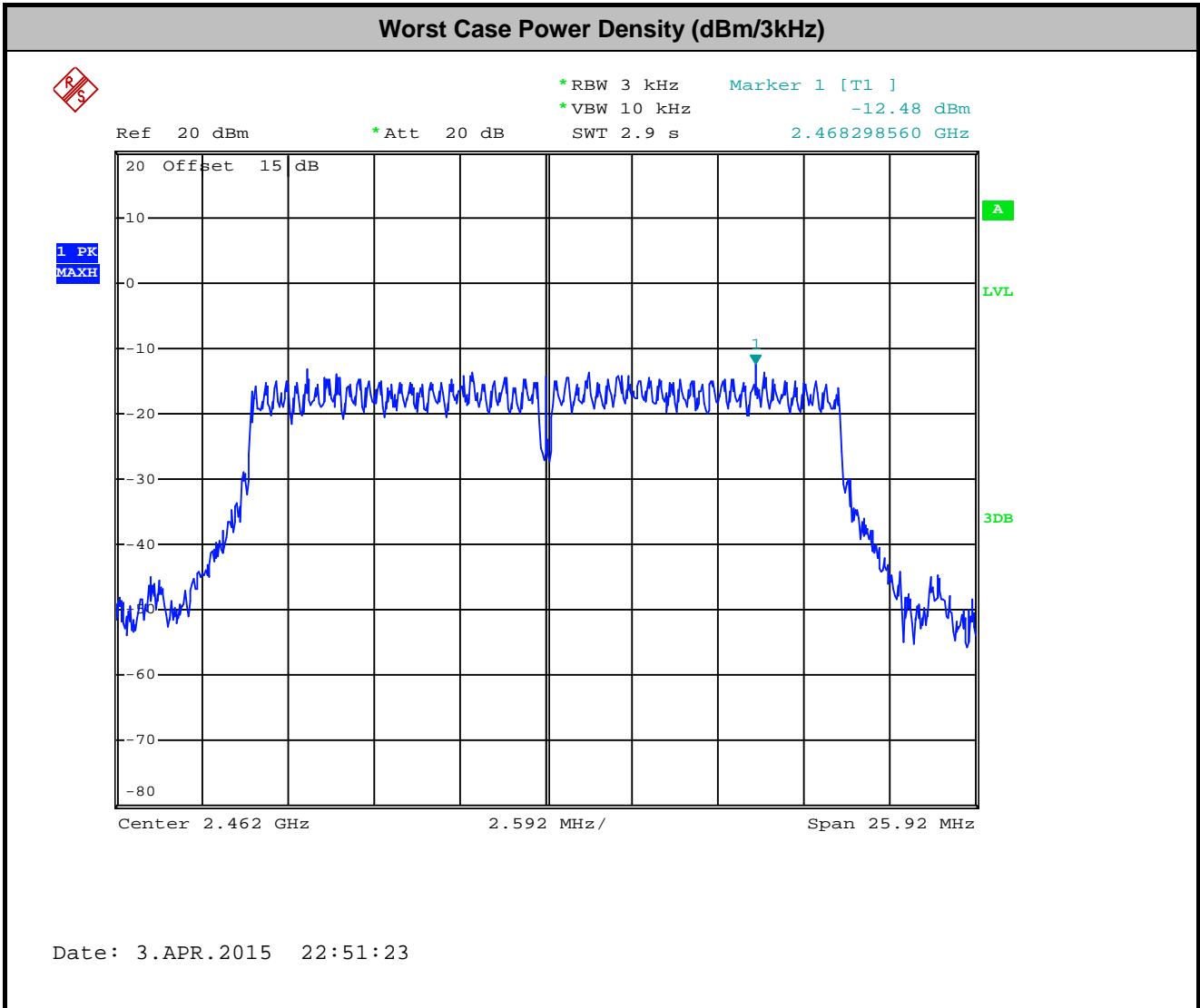

## 3.4 Conducted Band Edges and Spurious Emission Measurement

### 3.4.1 Limit of Conducted Band Edges and Spurious Emission Measurement

In any 100 kHz bandwidth outside of the authorized frequency band, the emissions which fall in the non-restricted bands shall be attenuated at least 20 dB / 30dB relative to the maximum PSD level in 100 kHz by RF conducted measurement and radiated emissions which fall in the restricted bands, as defined in Section 15.205(a), must also comply with the radiated emission limits specified in Section 15.209(a).

### 3.4.2 Measuring Instruments

The measuring equipment is listed in the section 4 of this test report.

### 3.4.3 Test Procedures

1. The testing follows FCC KDB Publication No. 558074 D01 DTS Meas. Guidance v03r02.
2. The RF output of EUT was connected to the spectrum analyzer by RF cable and attenuator. The path loss was compensated to the results for each measurement.
3. Set to the maximum power setting and enable the EUT transmit continuously.
4. Set RBW = 100 kHz, VBW=300 kHz, Peak Detector. Unwanted Emissions measured in any 100 kHz bandwidth outside of the authorized frequency band shall be attenuated by at least 20 dB relative to the maximum in-band peak PSD level in 100 kHz when maximum peak conducted output power procedure is used. If the transmitter complies with the conducted power limits based on the use of RMS averaging over a time interval, the attenuation required under this paragraph shall be 30 dB instead of 20 dB per 15.247(d).
5. Measure and record the results in the test report.
6. The RF fundamental frequency should be excluded against the limit line in the operating frequency band.

### 3.4.4 Test Setup

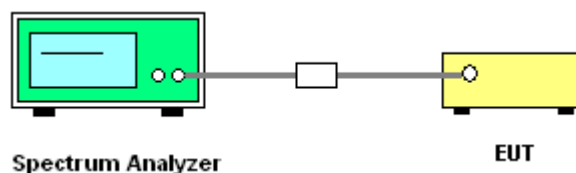



### 3.4.5 Test Result of Conducted Band Edges and Spurious Emission

Test Mode :	802.11b	Temperature :	21~25°C
Test Band :	2.4GHz Low	Relative Humidity :	51~54%
Test Channel :	01	Test Engineer :	Fire Chai

#### WLAN 802.11b Channel 01

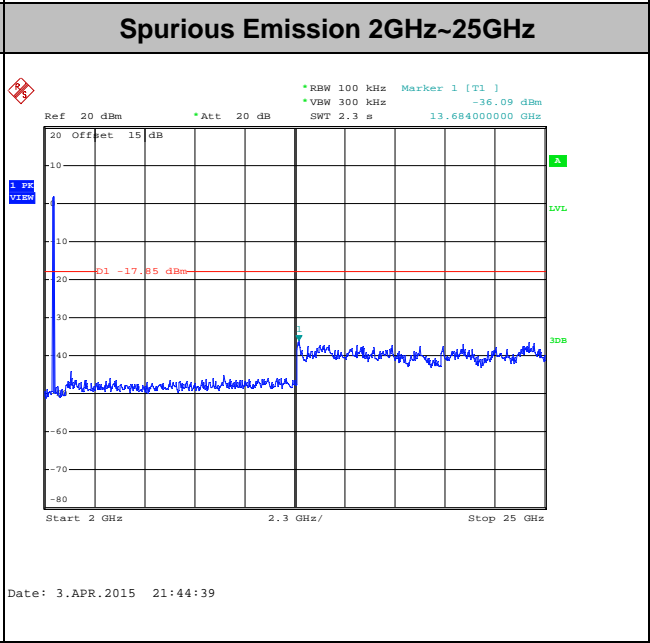
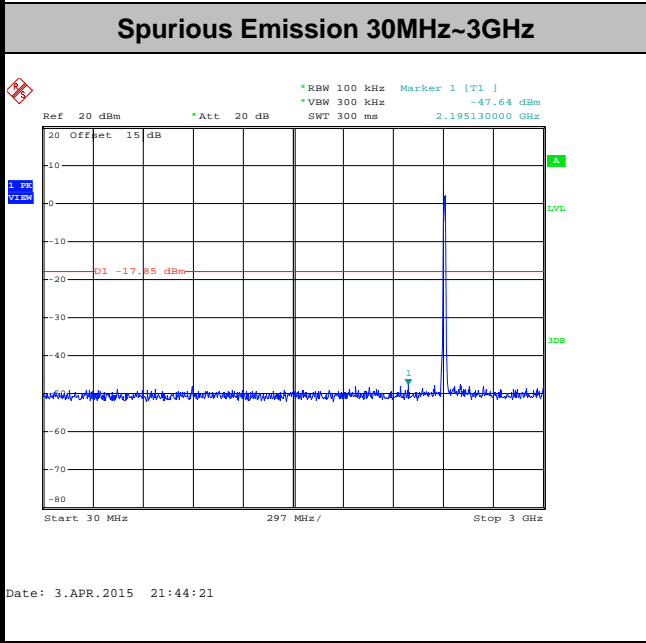
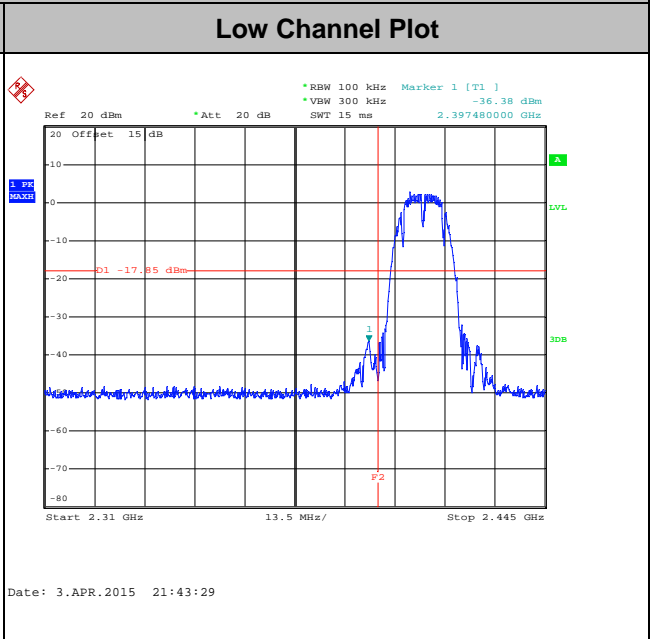
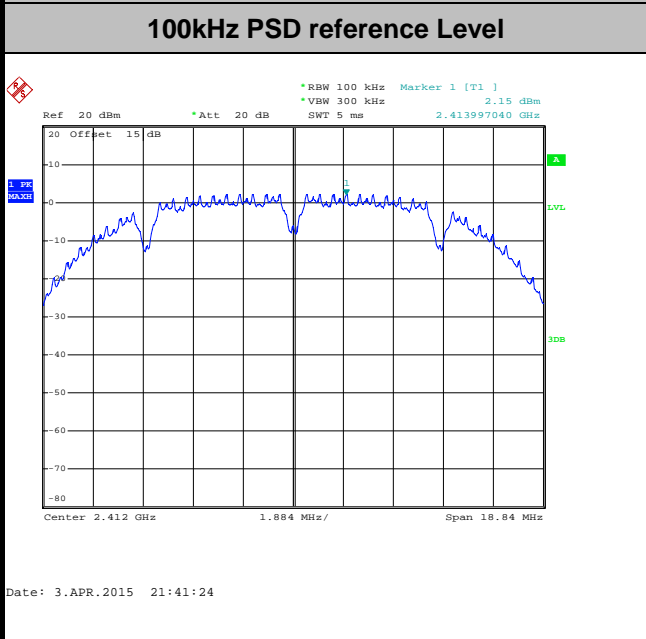



Test Mode :	802.11b	Temperature :	21~25°C
Test Band :	2.4GHz Mid	Relative Humidity :	51~54%
Test Channel :	06	Test Engineer :	Fire Chai

WLAN 802.11b Channel 06

100kHz PSD reference Level

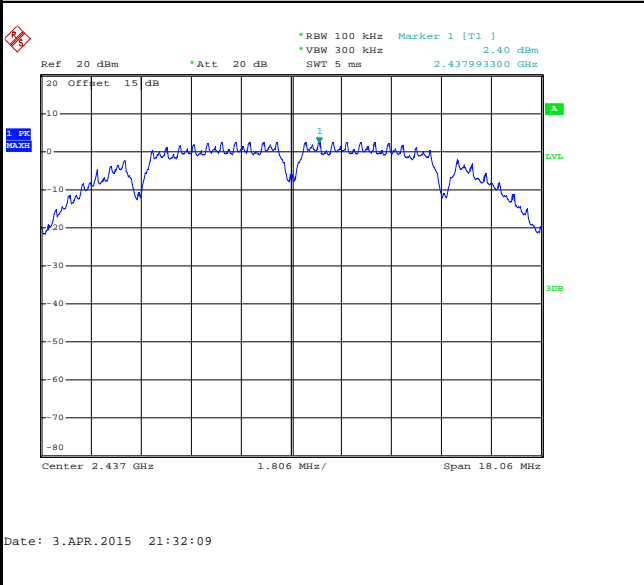

Spurious Emission 30MHz~3GHz

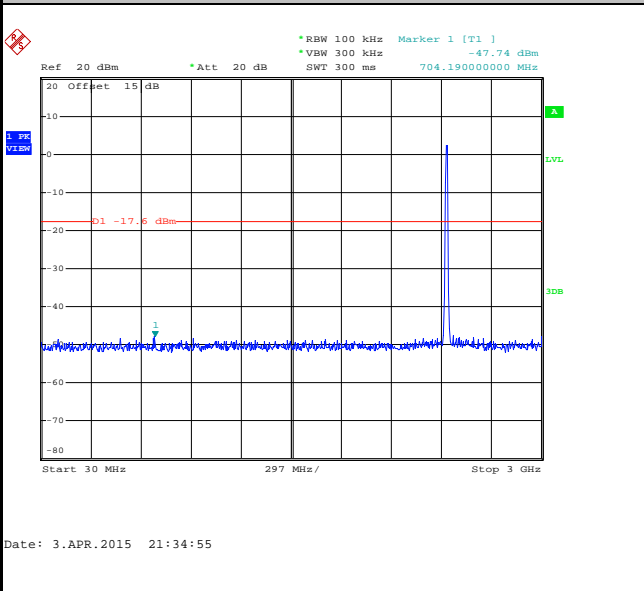

Spurious Emission 2GHz~25GHz

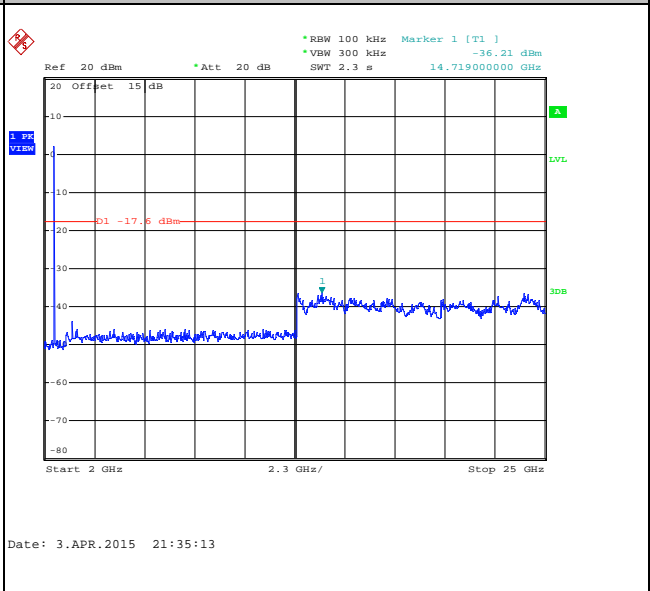



Test Mode :	802.11b	Temperature :	21~25°C
Test Band :	2.4GHz High	Relative Humidity :	51~54%
Test Channel :	11	Test Engineer :	Fire Chai

WLAN 802.11b Channel 11

100kHz PSD reference Level

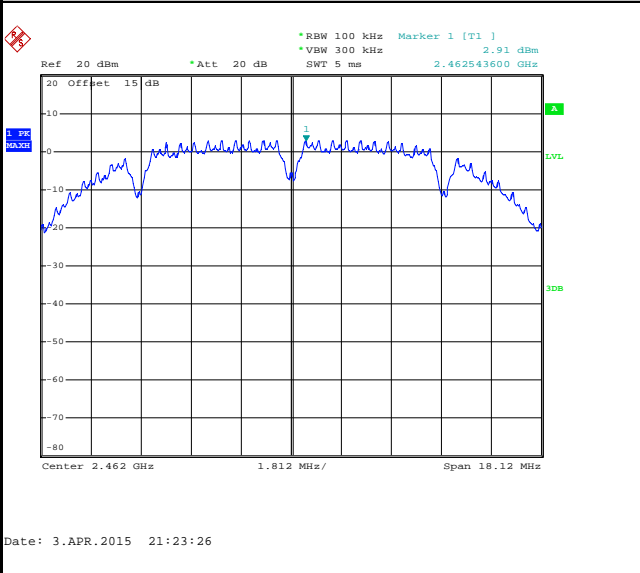

High Channel Plot

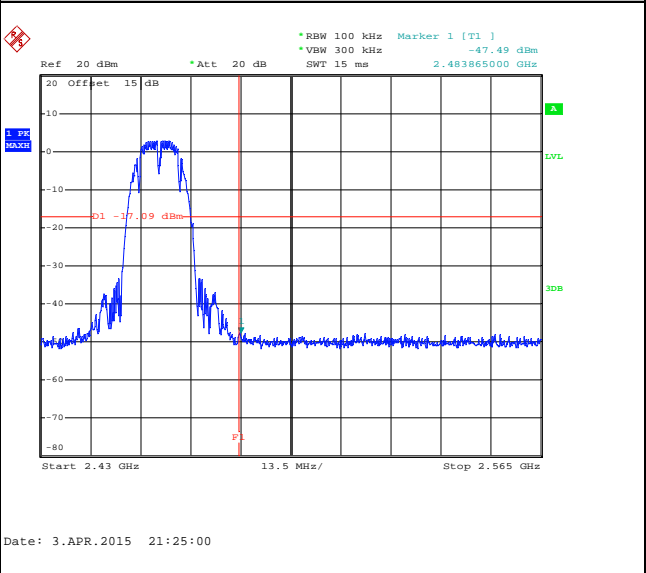

Spurious Emission 30MHz~3GHz

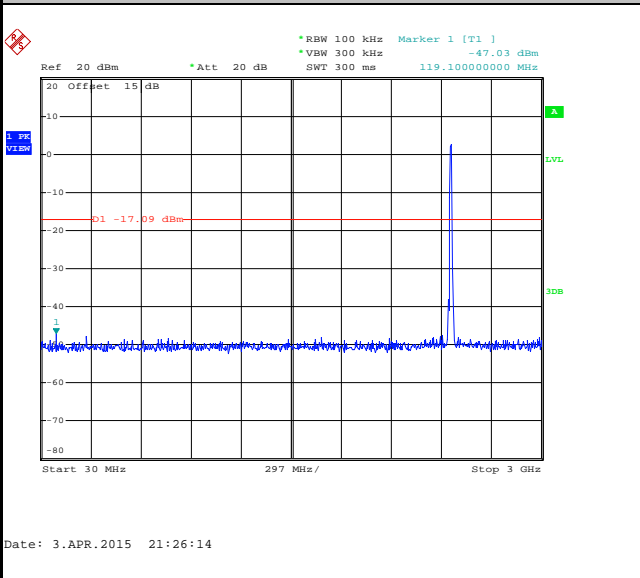

Spurious Emission 2GHz~25GHz

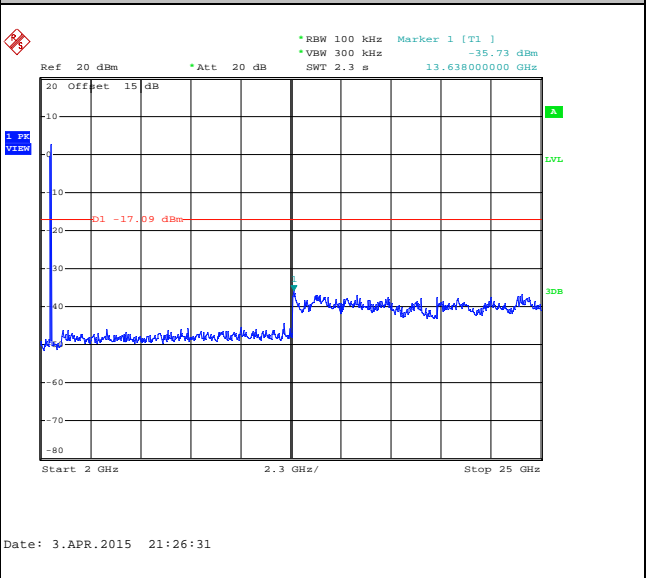



Test Mode :	802.11g	Temperature :	21~25°C
Test Band :	2.4GHz Low	Relative Humidity :	51~54%
Test Channel :	01	Test Engineer :	Fire Chai

WLAN 802.11g Channel 01

100kHz PSD reference Level

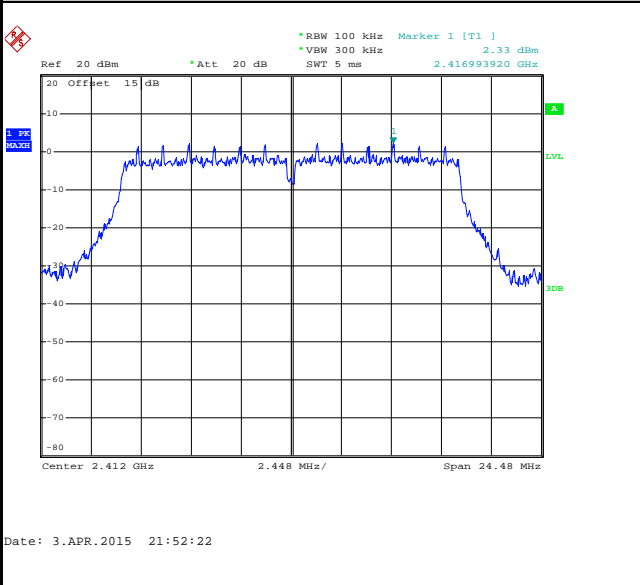

Low Channel Plot

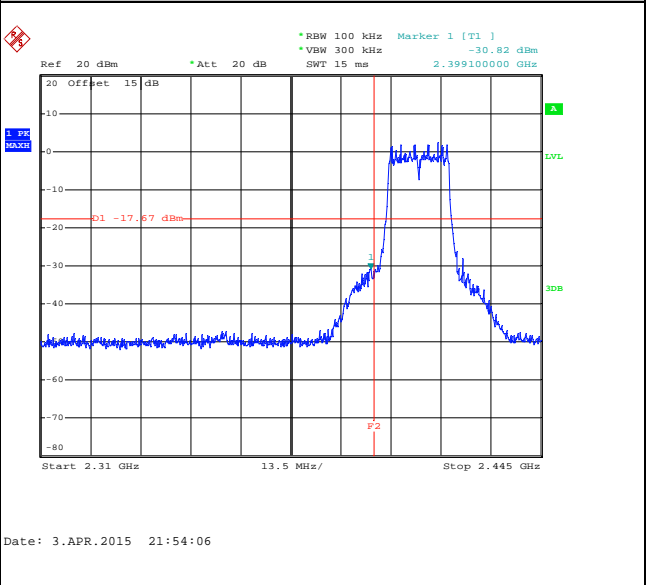

Spurious Emission 30MHz~3GHz

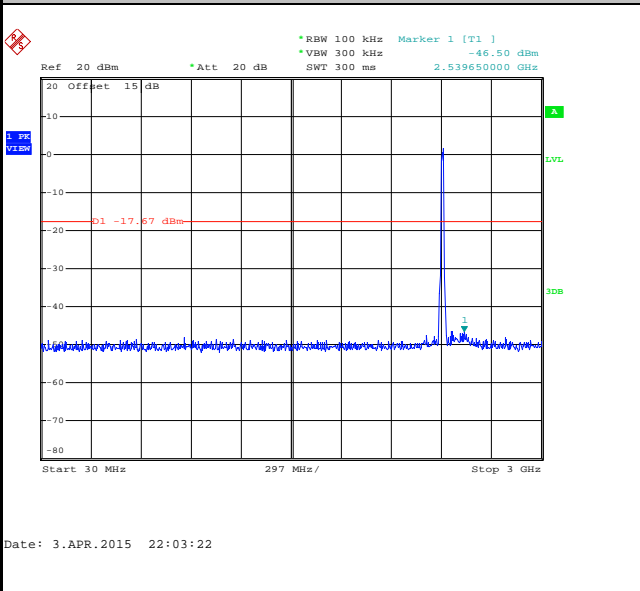

Spurious Emission 2GHz~25GHz

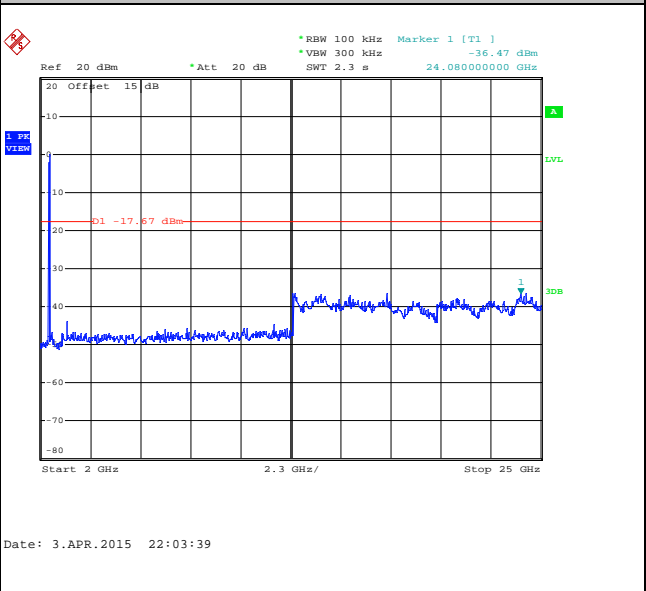



Test Mode :	802.11g	Temperature :	21~25°C
Test Band :	2.4GHz Mid	Relative Humidity :	51~54%
Test Channel :	06	Test Engineer :	Fire Chai

WLAN 802.11g Channel 06

100kHz PSD reference Level

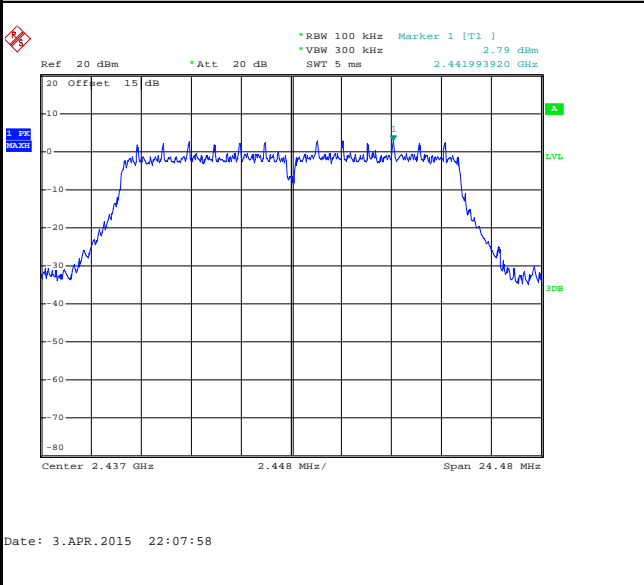

Spurious Emission 30MHz~3GHz

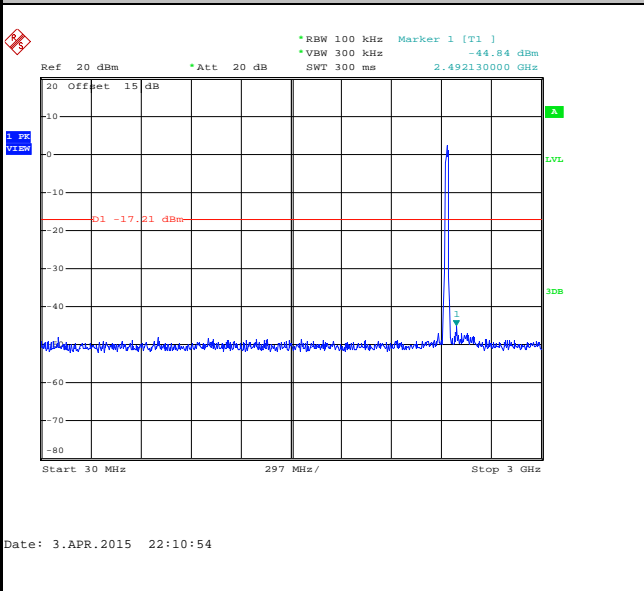

Spurious Emission 2GHz~25GHz

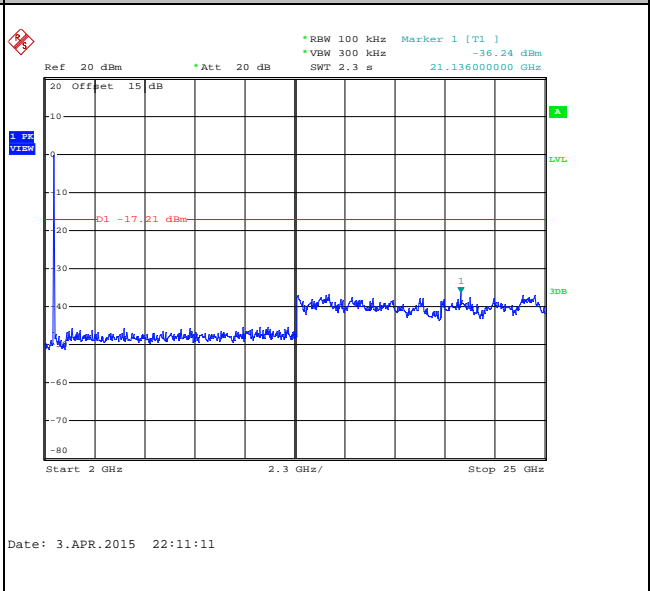



Test Mode :	802.11g	Temperature :	24~26°C
Test Band :	2.4GHz High	Relative Humidity :	50~53%
Test Channel :	11	Test Engineer :	Fire Chai

WLAN 802.11g Channel 11

100kHz PSD reference Level

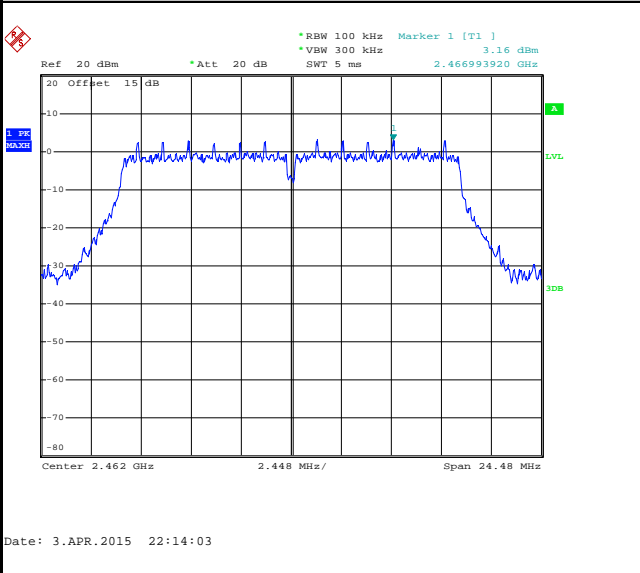

High Channel Plot

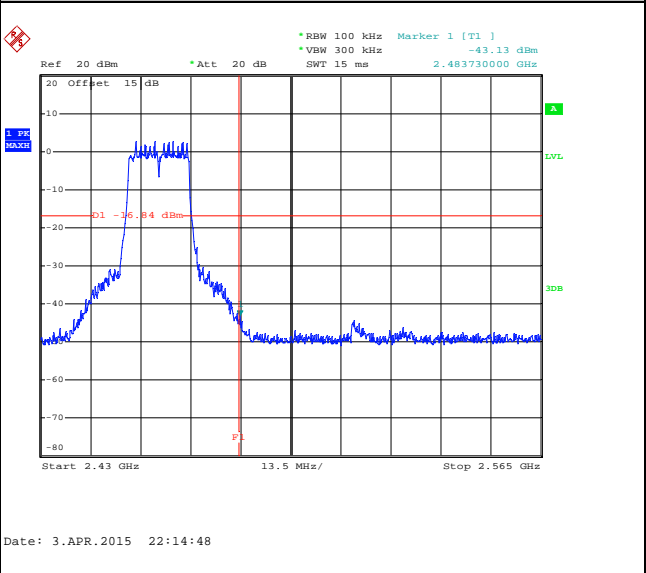

Spurious Emission 30MHz~3GHz

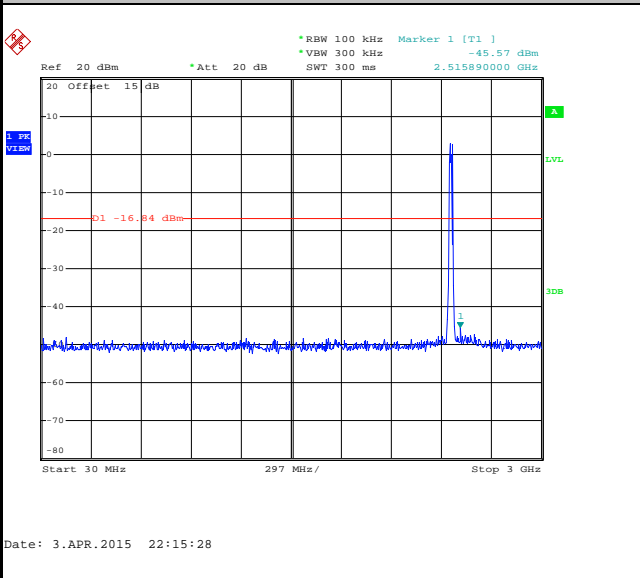

Spurious Emission 2GHz~25GHz

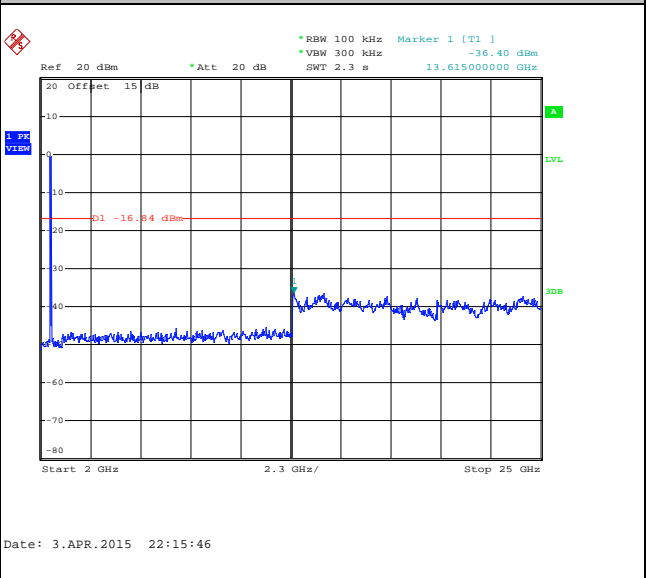





Test Mode :	802.11n HT20	Temperature :	21~25°C
Test Band :	2.4GHz Low	Relative Humidity :	51~54%
Test Channel :	01	Test Engineer :	Fire Chai

WLAN 802.11n HT20 Channel 01

100kHz PSD reference Level

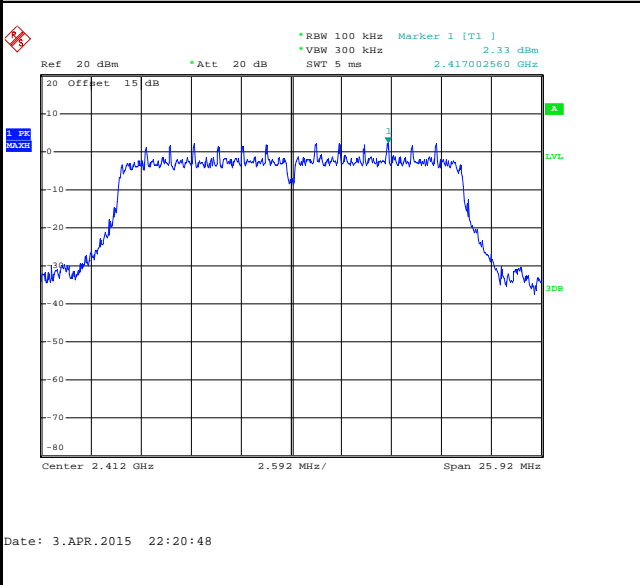

Low Channel Plot

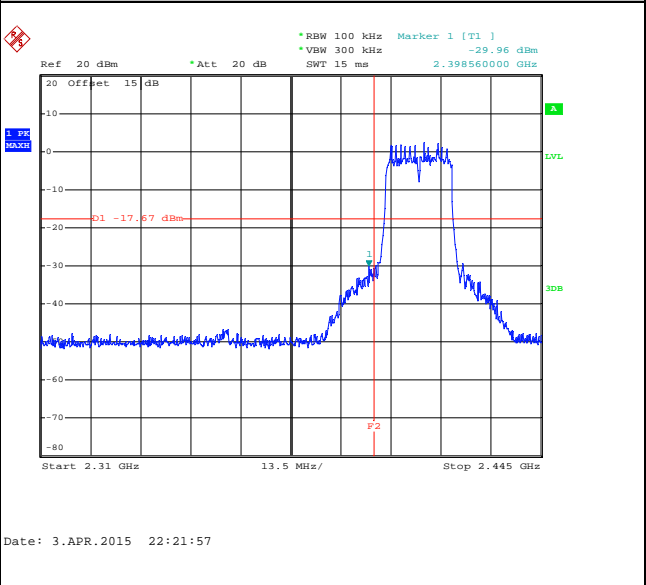

Spurious Emission 30MHz~3GHz

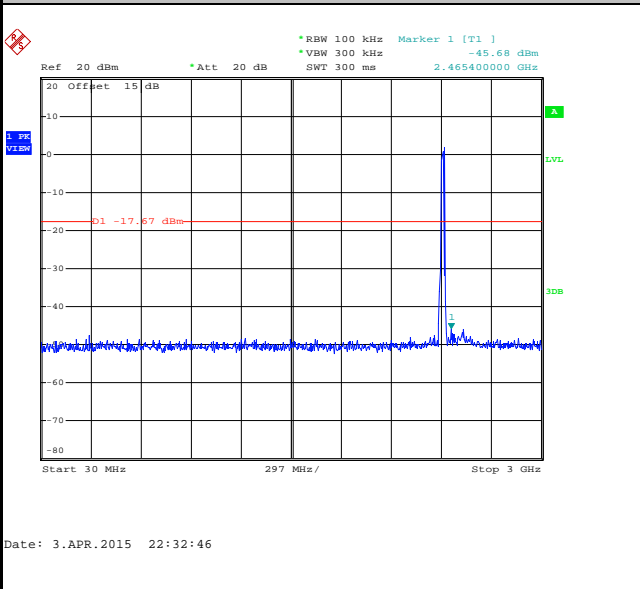

Spurious Emission 2GHz~25GHz

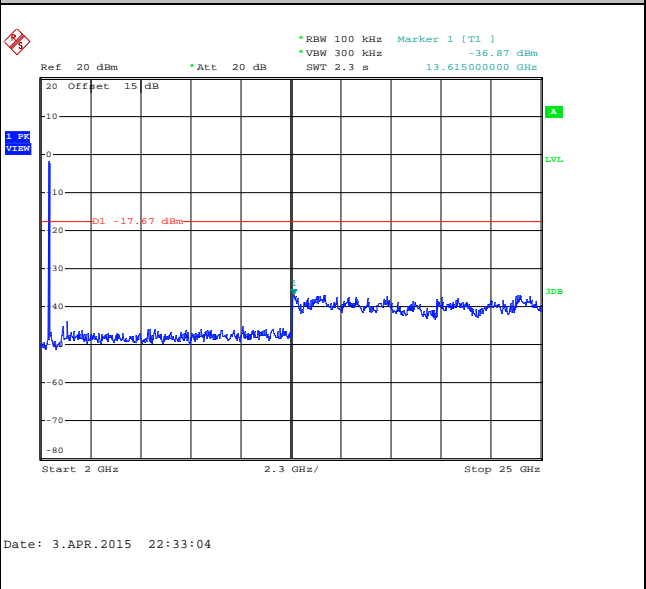



Test Mode :	802.11n HT20	Temperature :	21~25°C
Test Band :	2.4GHz Mid	Relative Humidity :	51~54%
Test Channel :	06	Test Engineer :	Fire Chai

WLAN 802.11n HT20 Channel 06

100kHz PSD reference Level

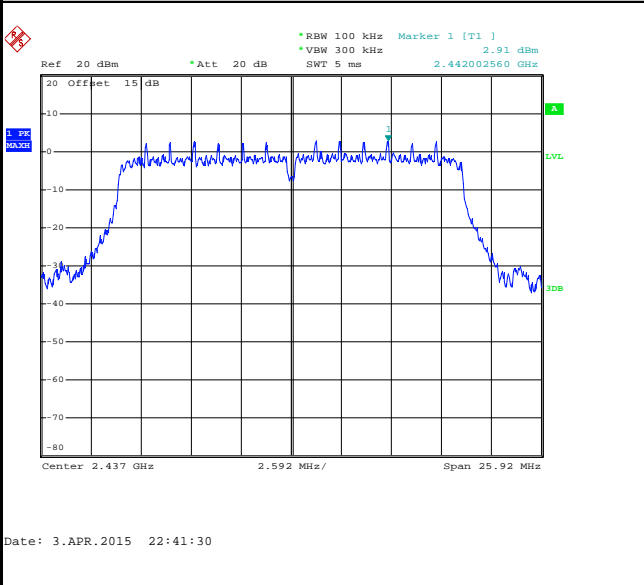

Spurious Emission 30MHz~3GHz

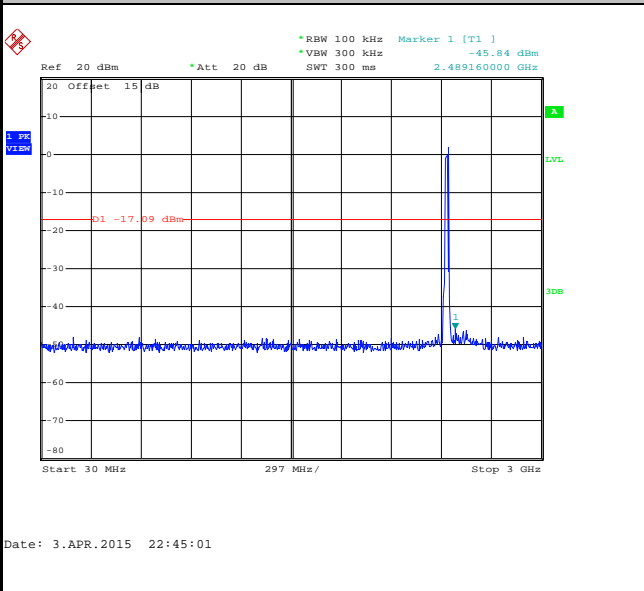

Spurious Emission 2GHz~25GHz

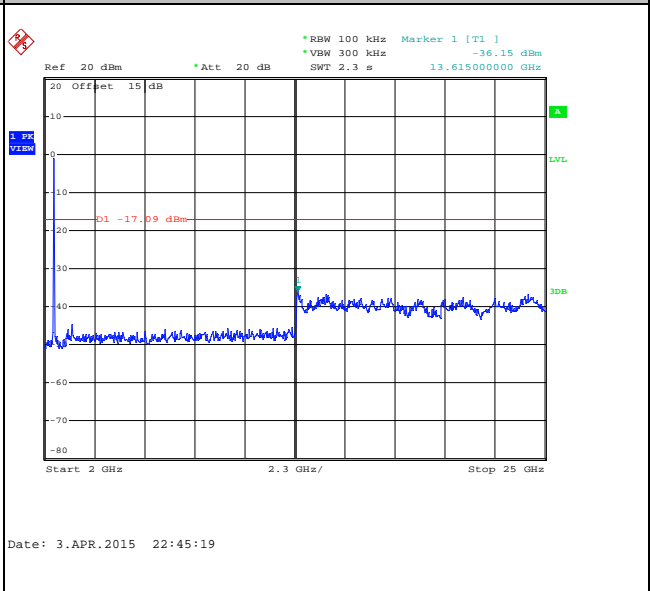



Test Mode :	802.11n HT20	Temperature :	21~25°C
Test Band :	2.4GHz High	Relative Humidity :	51~54%
Test Channel :	11	Test Engineer :	Fire Chai

WLAN 802.11n HT20 Channel 11

100kHz PSD reference Level

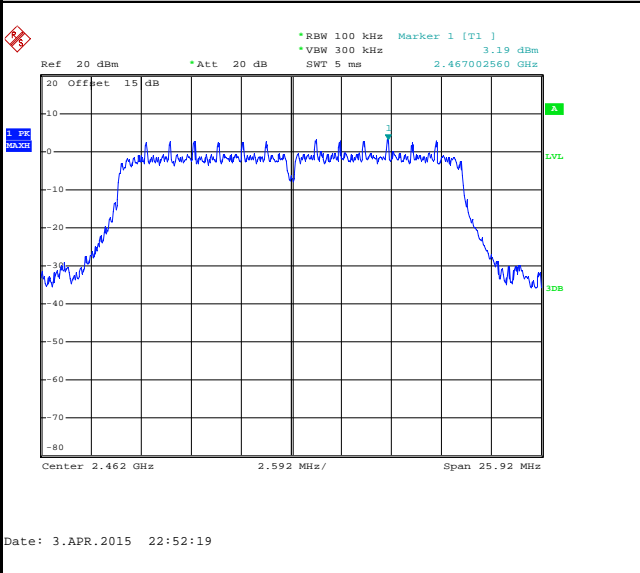

High Channel Plot

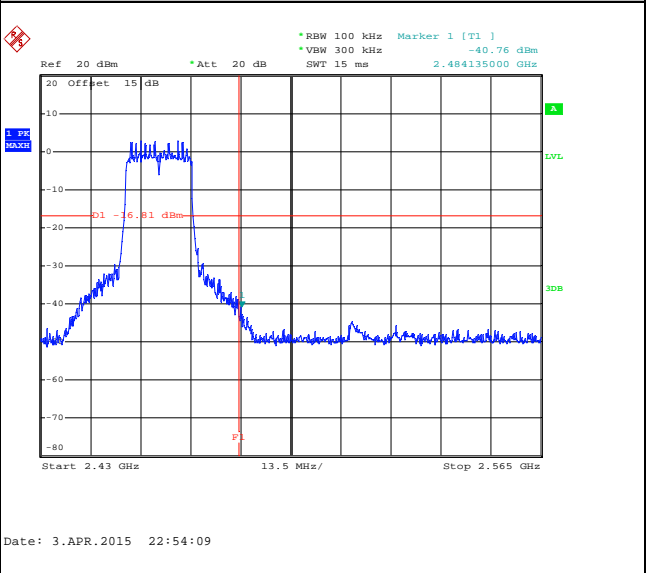

Spurious Emission 30MHz~3GHz

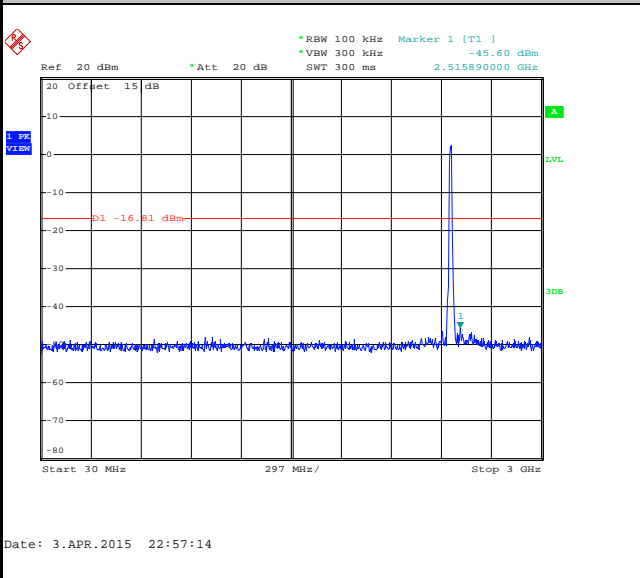

Spurious Emission 2GHz~25GHz

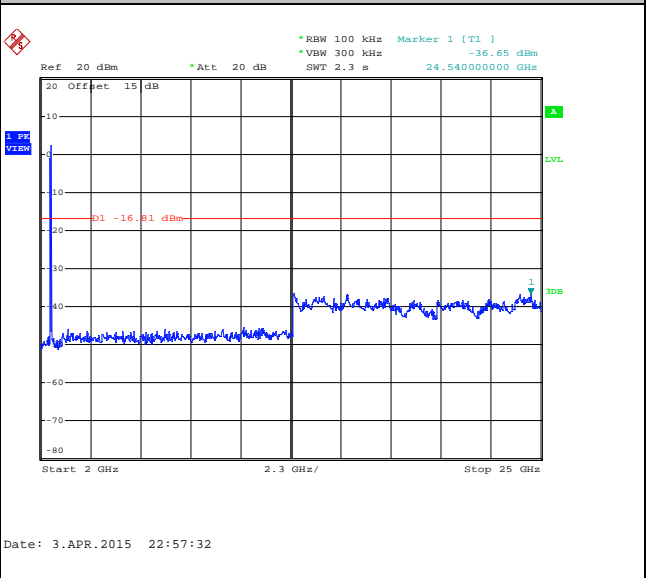



Test Mode :	802.11n HT40	Temperature :	21~25°C
Test Band :	2.4GHz Low	Relative Humidity :	51~54%
Test Channel :	03	Test Engineer :	Fire Chai

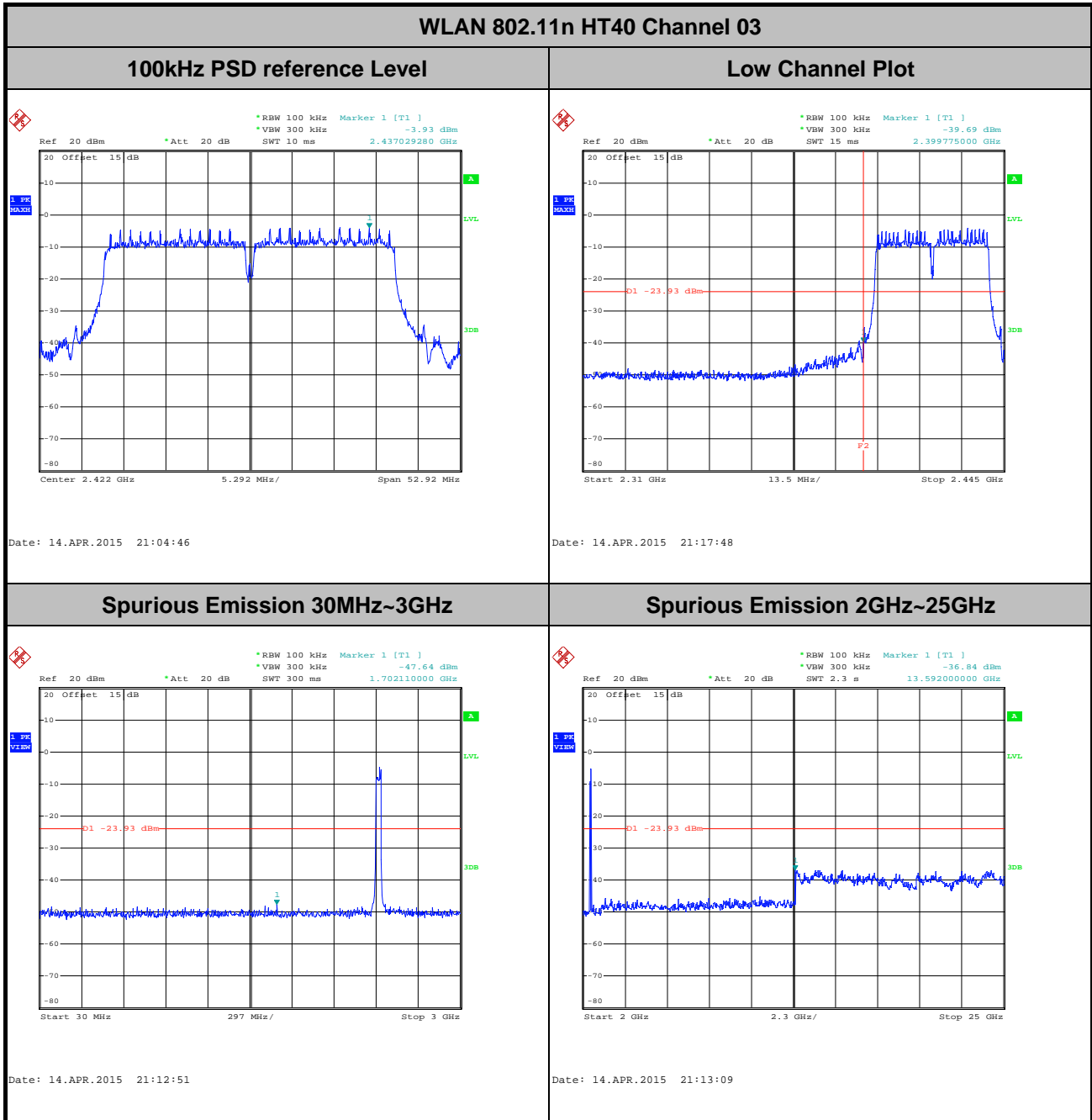



Test Mode :	802.11n HT40	Temperature :	21~25°C
Test Band :	2.4GHz Mid	Relative Humidity :	51~54%
Test Channel :	06	Test Engineer :	Fire Chai

WLAN 802.11n HT40 Channel 06

100kHz PSD reference Level

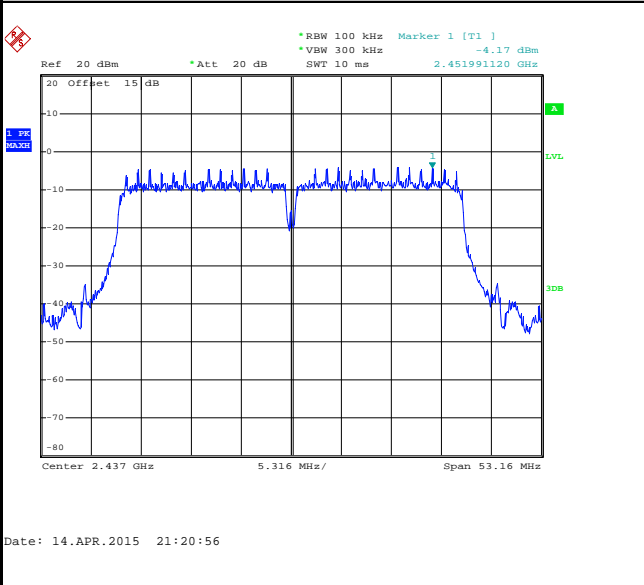

Spurious Emission 30MHz~3GHz

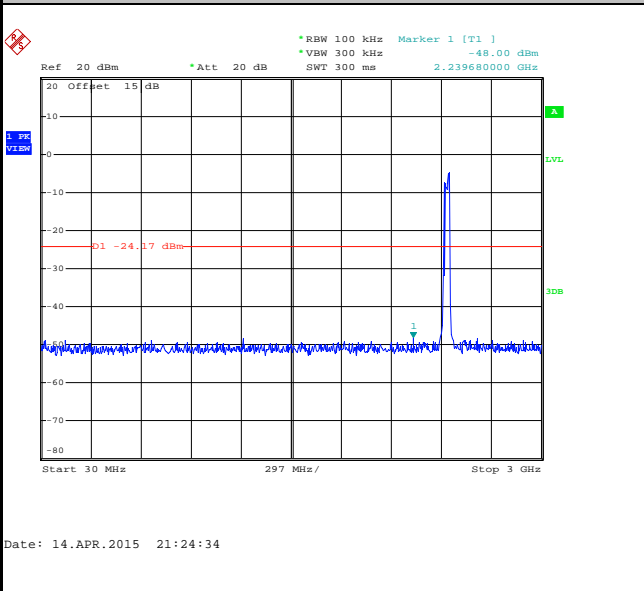

Spurious Emission 2GHz~25GHz

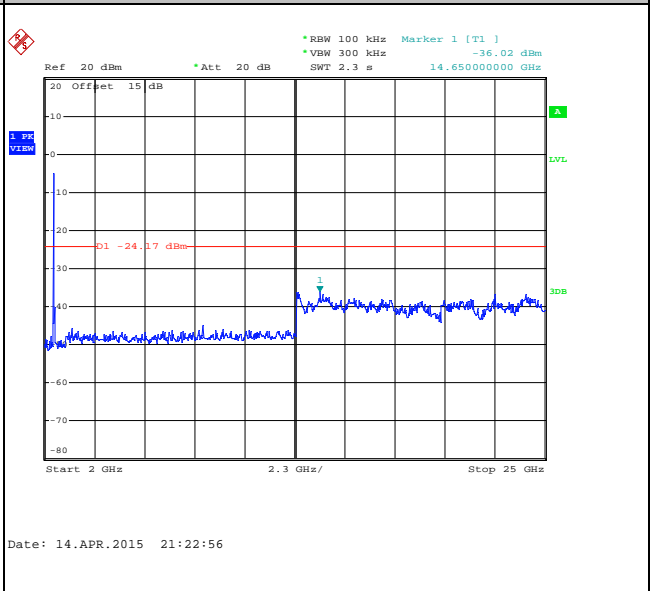



Test Mode :	802.11n HT40	Temperature :	21~25°C
Test Band :	2.4GHz High	Relative Humidity :	51~54%
Test Channel :	09	Test Engineer :	Fire Chai

WLAN 802.11n HT40 Channel 09

100kHz PSD reference Level

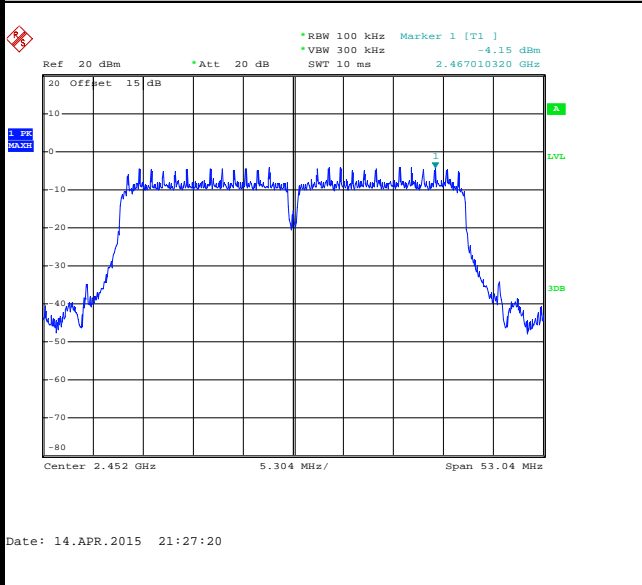

High Channel Plot

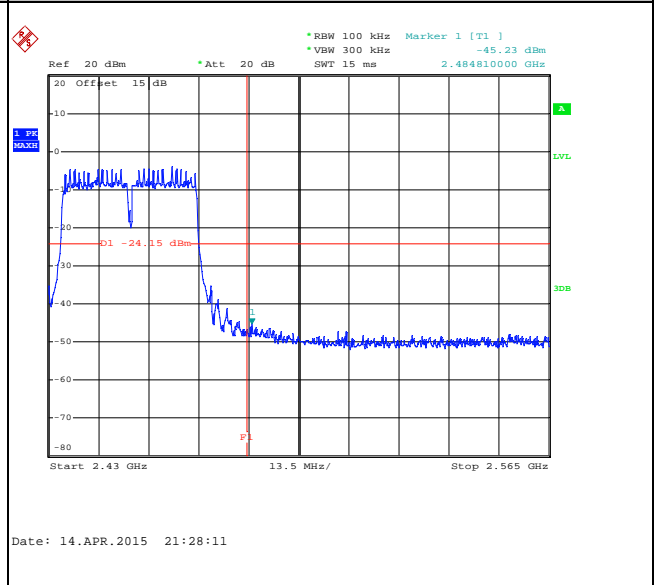

Spurious Emission 30MHz~3GHz

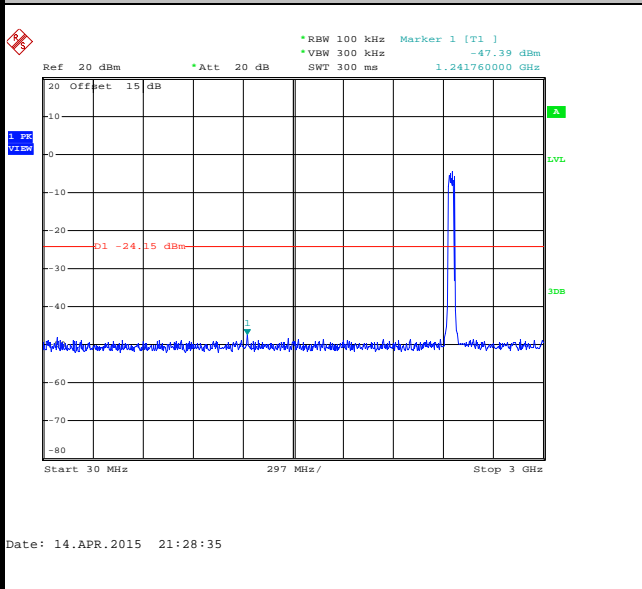

Spurious Emission 2GHz~25GHz

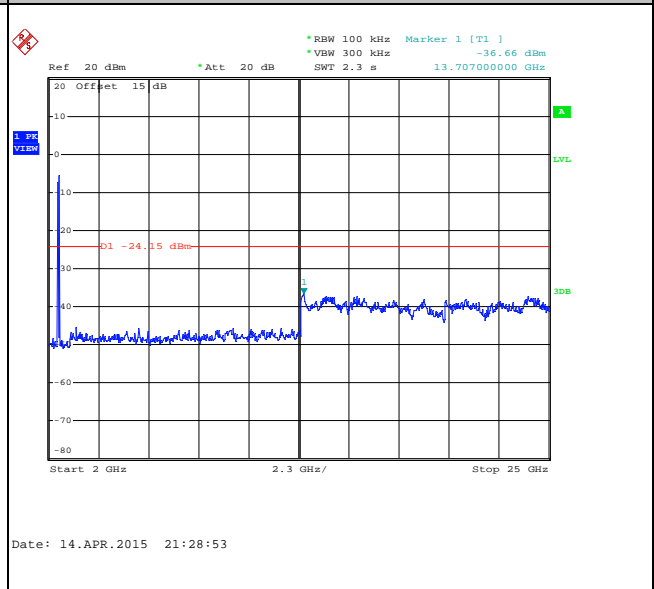



### 3.5 Radiated Band Edges and Spurious Emission Measurement

#### 3.5.1 Limit of Radiated band edge and Spurious Emission Measurement

In any 100 kHz bandwidth outside the intentional radiator frequency band, all harmonics/spurious must be at least 20 dB below the highest emission level within the authorized band. If the output power of this device was measured by spectrum analyzer, the attenuation under this paragraph shall be 30 dB instead of 20 dB. In addition, radiated emissions which fall in the restricted bands must also comply with the FCC section 15.209 limits as below.

Frequency (MHz)	Field Strength (microvolts/meter)	Measurement Distance (meters)
0.009 – 0.490	2400/F(kHz)	300
0.490 – 1.705	24000/F(kHz)	30
1.705 – 30.0	30	30
30 – 88	100	3
88 – 216	150	3
216 - 960	200	3
Above 960	500	3

#### 3.5.2 Measuring Instruments

The measuring equipment is listed in the section 4 of this test report.



3.5.3 Test Procedures

1. The testing follows FCC KDB Publication No. 558074 D01 DTS Meas. Guidance v03r02.
2. The EUT was arranged to its worst case and then tune the antenna tower (from 1 m to 4 m) and turntable (from 0 degree to 360 degrees) to find the maximum reading. A pre-amp and a high pass filter are used for the test in order to get better signal level.
3. The EUT was placed on a turntable with 0.8 meter for frequency below 1GHz and 1.5 meter for frequency above 1GHz respectively above ground.
4. The EUT was set 3 meters from the interference receiving antenna, which was mounted on the top of a variable height antenna tower.
5. Corrected Reading: Antenna Factor + Cable Loss + Read Level - Preamp Factor = Level
6. For measurement below 1GHz, If the emission level of the EUT measured by the peak detector is 3 dB lower than the applicable limit, the peak emission level will be reported. Otherwise, the emission measurement will be repeated using the quasi-peak detector and reported.
7. Use the following spectrum analyzer settings:
  - (1) Span shall wide enough to fully capture the emission being measured;
  - (2) Set RBW=100 kHz for  $f < 1$  GHz;  $VBW \geq RBW$ ; Sweep = auto; Detector function = peak; Trace = max hold;
  - (3) Set RBW = 1 MHz, VBW= 3MHz for  $f \geq 1$  GHz for peak measurement.

For average measurement:

  - $VBW = 10$  Hz, when duty cycle is no less than 98 percent.
  - $VBW \geq 1/T$ , when duty cycle is less than 98 percent where T is the minimum transmission duration over which the transmitter is on and is transmitting at its maximum power control level for the tested mode of operation.

Band	Duty Cycle(%)	T(ms)	1/T(kHz)	VBW Setting
802.11b	97.75	8.70	0.11	300Hz
802.11g	87.88	1.45	0.69	1kHz
2.4GHz 802.11n HT20	86.87	1.35	0.74	1kHz
2.4GHz 802.11n HT40	76.71	0.67	1.49	3kHz



### 3.5.4 Test Setup

For radiated emissions below 30MHz

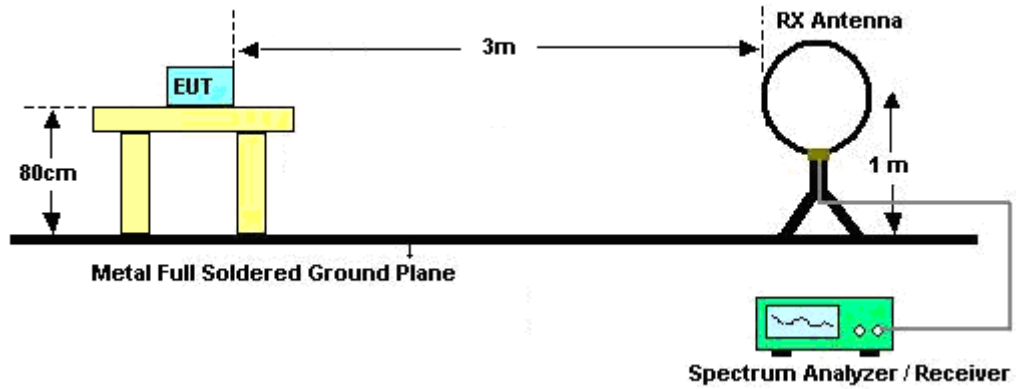

For radiated emissions from 30MHz to 1GHz

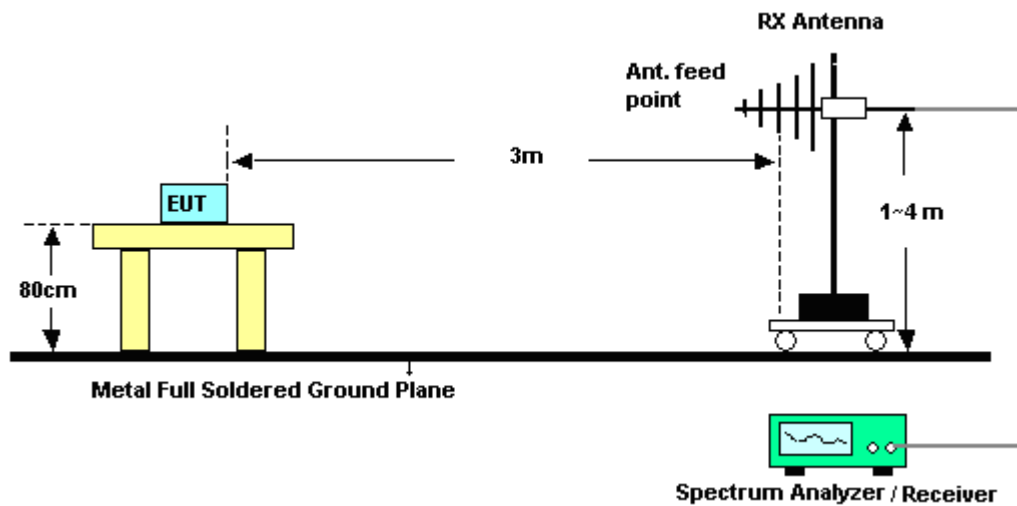

For radiated emissions above 1GHz

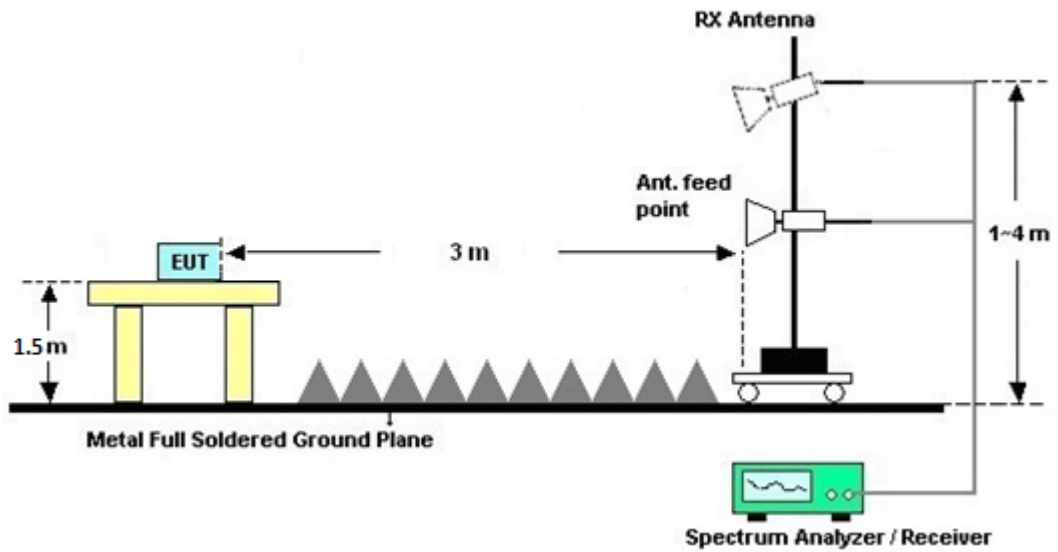

### 3.5.5 Test Results of Radiated Spurious Emissions (9kHz ~ 30MHz)

The low frequency, which started from 9 kHz to 30MHz, was pre-scanned and the result which was 20dB lower than the limit line per 15.31(o) was not reported.

### 3.5.6 Test Result of Radiated Spurious at Band Edges

Please refer to Appendix B.

### 3.5.7 Test Result of Radiated Spurious Emission (30MHz ~ 10<sup>th</sup> Harmonic)

Please refer to Appendix B.



## **3.6 Antenna Requirements**

### **3.6.1 Standard Applicable**

If directional gain of transmitting antennas is greater than 6dBi, the power shall be reduced by the same level in dB comparing to gain minus 6dBi. For the fixed point-to-point operation, the power shall be reduced by one dB for every 3 dB that the directional gain of the antenna exceeds 6 dBi. The use of a permanently attached antenna or of an antenna that uses a unique coupling to the intentional radiator shall be considered sufficient to comply with the FCC rule.

### **3.6.2 Antenna Anti-Replacement Construction**

Device use external antennas with RP-SMA type connector.

### **3.6.3 Antenna Gain**

The antenna peak gain of EUT is less than 6 dBi. Therefore, it is not necessary to reduce maximum peak output power limit.



## 4 List of Measuring Equipment

Instrument	Manufacturer	Model No.	Serial No.	Characteristics	Calibration Date	Test Date	Due Date	Remark
Spectrum Analyzer	R&S	FSP30	101400	9kHz~30GHz	Jan. 28, 2015	Apr. 03, 2015~ Apr. 14, 2015	Jan. 27, 2016	Conducted (TH01-SZ)
Power Meter	Anritsu	ML2495A	1218010	10Hz~40GHz	Jan. 28, 2015	Apr. 03, 2015~ Apr. 14, 2015	Jan. 27, 2016	Conducted (TH01-SZ)
Power Sensor	Anritsu	MA2411B	1207253	0.3GHz~40GHz	Jan. 28, 2015	Apr. 03, 2015~ Apr. 14, 2015	Jan. 27, 2016	Conducted (TH01-SZ)
EMI Test Receiver&SA	Agilent Technologies	N9038A	MY522601 85	20Hz~26.5GHz	May 26, 2014	Apr. 16, 2015	May 25, 2015	Radiation (03CH01-SZ)
Spectrum Analyzer	R&S	FSV40	101041	10kHz~40GHz; Max 30dBm	Sep. 25, 2014	Apr. 16, 2015	Sep. 24, 2015	Radiation (03CH01-SZ)
Loop Antenna	R&S	HFH2-Z2	100354	9kHz~30MHz	May 09, 2014	Apr. 16, 2015	May 08, 2015	Radiation (03CH01-SZ)
Bilog Antenna	TeseQ	CBL6112D	23188	30MHz~2GHz	Nov. 07, 2014	Apr. 16, 2015	Sep. 06, 2015	Radiation (03CH01-SZ)
Double Ridge Horn Antenna	ETS-Lindgren	3117	00119436	1GHz~18GHz	Oct. 15, 2014	Apr. 16, 2015	Oct. 14, 2015	Radiation (03CH01-SZ)
SHF-EHF Horn	com-power	AH-840	101073	18GHz~40GHz	Jun. 09, 2014	Apr. 16, 2015	Jun. 08, 2015	Radiation (03CH01-SZ)
Amplifier	ADVANTEST	BB525C	E9007003	9kHz~3000MHz / 30 dB	Jan. 28, 2015	Apr. 16, 2015	Jan. 27, 2016	Radiation (03CH01-SZ)
Amplifier	Agilent	8449B	3008A010 23	1GHz~26.5GHz	Oct. 29, 2014	Apr. 16, 2015	Oct. 28, 2015	Radiation (03CH01-SZ)
AC Power Source	Chroma	61601	616010001 985	N/A	NCR	Apr. 16, 2015	NCR	Radiation (03CH01-SZ)
Turn Table	EM	EM1000	N/A	0~360 degree	NCR	Apr. 16, 2015	NCR	Radiation (03CH01-SZ)
Antenna Mast	EM	EM1000	N/A	1 m~4 m	NCR	Apr. 16, 2015	NCR	Radiation (03CH01-SZ)



## 5 Uncertainty of Evaluation

### Uncertainty of Radiated Emission Measurement (30 MHz ~ 1000 MHz)

Measuring Uncertainty for a Level of Confidence of 95% ( $U = 2Uc(y)$ )	3.9dB
---	-------



## **Appendix A. Conducted Test Results**

Report Number : FR531712

Test Engineer:	Fire Chai	Temperature:	21~25	°C
Test Date:	2015/4/14	Relative Humidity:	51~54	%

**TEST RESULTS DATA**  
**6dB and 99% Occupied Bandwidth**

2.4GHz Band								
Mod.	Data Rate	N <sub>TX</sub>	CH.	Freq. (MHz)	99% Occupied BW (MHz)	6dB BW (MHz)	6dB BW Limit (MHz)	Pass/Fail
11b	1Mbps	1	1	2412	15.25	12.56	0.50	Pass
11b	1Mbps	1	6	2437	15.20	12.04	0.50	Pass
11b	1Mbps	1	11	2462	15.20	12.08	0.50	Pass
11g	6Mbps	1	1	2412	17.60	16.32	0.50	Pass
11g	6Mbps	1	6	2437	17.45	16.32	0.50	Pass
11g	6Mbps	1	11	2462	17.55	16.32	0.50	Pass
HT20	MCS0	1	1	2412	18.30	17.28	0.50	Pass
HT20	MCS0	1	6	2437	18.30	17.28	0.50	Pass
HT20	MCS0	1	11	2462	18.35	17.28	0.50	Pass
HT40	MCS0	1	3	2422	36.40	35.28	0.50	Pass
HT40	MCS0	1	6	2437	36.40	35.44	0.50	Pass
HT40	MCS0	1	9	2452	36.40	35.36	0.50	Pass



**TEST RESULTS DATA**  
**Peak Power Table**

2.4GHz Band										
Mod.	Data Rate	N <sub>TX</sub>	CH.	Freq. (MHz)	Peak Conducted Power (dBm)	Conducted Power Limit (dBm)	DG (dBi)	EIRP Power (dBm)	EIRP Power Limit (dBm)	Pass /Fail
11b	1Mbps	1	1	2412	16.67	30.00	3.80	20.47	36.00	Pass
11b	1Mbps	1	6	2437	16.79	30.00	3.80	20.59	36.00	Pass
11b	1Mbps	1	11	2462	16.92	30.00	3.80	20.72	36.00	Pass
11g	6Mbps	1	1	2412	22.58	30.00	3.80	26.38	36.00	Pass
11g	6Mbps	1	6	2437	23.12	30.00	3.80	26.92	36.00	Pass
11g	6Mbps	1	11	2462	23.35	30.00	3.80	27.15	36.00	Pass
HT20	MCS0	1	1	2412	21.24	30.00	3.80	25.04	36.00	Pass
HT20	MCS0	1	6	2437	21.71	30.00	3.80	25.51	36.00	Pass
HT20	MCS0	1	11	2462	22.21	30.00	3.80	26.01	36.00	Pass
HT40	MCS0	1	3	2422	19.24	30.00	3.80	23.04	36.00	Pass
HT40	MCS0	1	6	2437	19.86	30.00	3.80	23.66	36.00	Pass
HT40	MCS0	1	9	2452	19.99	30.00	3.80	23.79	36.00	Pass

**TEST RESULTS DATA**  
**Average Power Table**  
**(Reporting Only)**

2.4GHz Band						
Mod.	Data Rate	N <sub>TX</sub>	CH.	Freq. (MHz)	Duty Factor (dB)	Average Conducted Power (dBm)
11b	1Mbps	1	1	2412	0.10	14.25
11b	1Mbps	1	6	2437	0.10	14.35
11b	1Mbps	1	11	2462	0.10	14.48
11g	6Mbps	1	1	2412	0.56	13.02
11g	6Mbps	1	6	2437	0.56	13.45
11g	6Mbps	1	11	2462	0.56	13.56
HT20	MCS0	1	1	2412	0.61	11.90
HT20	MCS0	1	6	2437	0.61	12.23
HT20	MCS0	1	11	2462	0.61	12.60
HT40	MCS0	1	3	2422	1.15	9.46
HT40	MCS0	1	6	2437	1.15	10.00
HT40	MCS0	1	9	2452	1.15	10.01

**TEST RESULTS DATA**  
**Peak Power Density**

2.4GHz Band								
Mod.	Data Rate	N <sub>TX</sub>	CH.	Freq. (MHz)	Peak PSD (dBm /3kHz)	DG (dBi)	Peak PSD Limit (dBm /3kHz)	Pass/Fail
11b	1Mbps	1	1	2412	-12.61	3.80	8.00	Pass
11b	1Mbps	1	6	2437	-12.81	3.80	8.00	Pass
11b	1Mbps	1	11	2462	-12.57	3.80	8.00	Pass
11g	6Mbps	1	1	2412	-14.14	3.80	8.00	Pass
11g	6Mbps	1	6	2437	-13.25	3.80	8.00	Pass
11g	6Mbps	1	11	2462	-12.90	3.80	8.00	Pass
HT20	MCS0	1	1	2412	-13.49	3.80	8.00	Pass
HT20	MCS0	1	6	2437	-13.57	3.80	8.00	Pass
HT20	MCS0	1	11	2462	-12.48	3.80	8.00	Pass
HT40	MCS0	1	3	2422	-20.08	3.80	8.00	Pass
HT40	MCS0	1	6	2437	-19.99	3.80	8.00	Pass
HT40	MCS0	1	9	2452	-19.31	3.80	8.00	Pass



## Appendix B. Radiated Spurious Emission

### 2.4GHz 2400~2483.5MHz

#### WIFI 802.11b (Band Edge @ 3m)

WIFI	Note	Frequency	Level	Over	Limit	Read	Antenna	Cable	Preamp	Ant	Table	Peak	Pol.
Ant.				Limit	Line	Level	Factor	Loss	Factor	Pos	Pos	Avg.	
1		( MHz )	( dBμV/m )	( dB )	( dBμV/m )	( dBμV )	( dB/m )	( dB )	( dB )	( cm )	( deg )	( P/A )	( H/V )
802.11b CH 01 2412MHz		2389.38	50.45	-23.55	74	53.62	27.25	6.04	36.46	150	345	P	H
		2389.92	39.32	-14.68	54	42.49	27.25	6.04	36.46	150	345	A	H
	*	2412	100.94	-	-	104.05	27.31	6.04	36.46	150	345	P	H
	*	2412	97.05	-	-	100.16	27.31	6.04	36.46	150	345	A	H
		2389.47	53.01	-20.99	74	56.18	27.25	6.04	36.46	150	75	P	V
		2389.65	42.31	-11.69	54	45.48	27.25	6.04	36.46	150	75	A	V
	*	2412	104.17	-	-	107.28	27.31	6.04	36.46	150	75	P	V
	*	2412	100.24	-	-	103.35	27.31	6.04	36.46	150	75	A	V
802.11b CH 06 2437MHz		2380.47	49.1	-24.9	74	52.37	27.19	6	36.46	150	350	P	H
		2381.46	36.84	-17.16	54	40.11	27.19	6	36.46	150	350	A	H
	*	2437	101.14	-	-	104.08	27.42	6.09	36.45	150	350	P	H
	*	2437	97.25	-	-	100.19	27.42	6.09	36.45	150	350	A	H
		2489.68	49.02	-24.98	74	51.7	27.6	6.17	36.45	150	350	P	H
		2490.8	36.86	-17.14	54	39.54	27.6	6.17	36.45	150	350	A	H
		2383.71	51.43	-22.57	74	54.66	27.19	6.04	36.46	150	75	P	V
		2381.55	40.07	-13.93	54	43.34	27.19	6	36.46	150	75	A	V
	*	2437	103.42	-	-	106.36	27.42	6.09	36.45	150	75	P	V
	*	2437	99.54	-	-	102.48	27.42	6.09	36.45	150	75	A	V
		2492.16	53.44	-20.56	74	56.11	27.6	6.17	36.44	150	75	P	V
	2490.48	41.36	-12.64	54	44.04	27.6	6.17	36.45	150	75	A	V	



<b>802.11b CH 11 2462MHz</b>	*	2462	100.66	-	-	103.5	27.48	6.13	36.45	150	350	P	H
	*	2462	96.84	-	-	99.68	27.48	6.13	36.45	150	350	A	H
		2483.52	50.42	-23.58	74	53.16	27.54	6.17	36.45	150	350	P	H
		2483.76	40.48	-13.52	54	43.22	27.54	6.17	36.45	150	350	A	H
	*	2462	104.13	-	-	106.97	27.48	6.13	36.45	150	84	P	V
	*	2462	100.31	-	-	103.15	27.48	6.13	36.45	150	84	A	V
		2483.84	55.5	-18.5	74	58.24	27.54	6.17	36.45	150	84	P	V
		2483.64	46.07	-7.93	54	48.81	27.54	6.17	36.45	150	84	A	V
<b>Remark</b>	1. No other spurious found. 2. All results are PASS against Peak and Average limit line.												



**2.4GHz 2400~2483.5MHz  
WIFI 802.11b (Harmonic @ 3m)**

WIFI Ant. 1	Note	Frequency ( MHz )	Level ( dBμV/m )	Over Limit ( dB )	Limit Line ( dBμV/m )	Read Level ( dBμV )	Antenna Factor ( dB/m )	Cable Loss ( dB )	Preamp Factor ( dB )	Ant Pos ( cm )	Table Pos ( deg )	Peak Avg. (P/A)	Pol. (H/V)
802.11b CH 01 2412MHz		4824	45.13	-28.87	74	41.58	31.26	8.23	35.94	105	198	P	H
		4824	44.93	-29.07	74	41.38	31.26	8.23	35.94	105	198	P	V
802.11b CH 06 2437MHz		4874	44.68	-29.32	74	40.95	31.36	8.29	35.92	145	265	P	H
		7311	50.52	-23.48	74	40.8	35.96	10.29	36.53	174	321	P	H
		4874	44.9	-29.1	74	41.17	31.36	8.29	35.92	145	265	P	V
		7311	50.16	-23.84	74	40.44	35.96	10.29	36.53	174	321	P	V
802.11b CH 11 2462MHz		4924	45.31	-28.69	74	41.43	31.46	8.32	35.9	146	347	P	H
		7386	49.53	-24.47	74	39.7	36.08	10.34	36.59	145	274	P	H
		4924	45.69	-28.31	74	41.81	31.46	8.32	35.9	146	347	P	V
		7386	50.37	-23.63	74	40.54	36.08	10.34	36.59	145	274	P	V
Remark	1. No other spurious found. 2. All results are PASS against Peak and Average limit line.												



**2.4GHz 2400~2483.5MHz**  
**WIFI 802.11g (Band Edge @ 3m)**

WIFI Ant. 1	Note	Frequency ( MHz )	Level ( dBμV/m )	Over Limit ( dB )	Limit Line ( dBμV/m )	Read Level ( dBμV )	Antenna Factor ( dB/m )	Cable Loss ( dB )	Preamp Factor ( dB )	Ant Pos ( cm )	Table Pos ( deg )	Peak Avg. ( P/A )	Pol. ( H/V )
802.11g CH 01 2412MHz		2389.83	58.96	-15.04	74	62.13	27.25	6.04	36.46	150	350	P	H
		2389.92	41.79	-12.21	54	44.96	27.25	6.04	36.46	150	350	A	H
	*	2412	103.42	-	-	106.53	27.31	6.04	36.46	150	350	P	H
	*	2412	92.27	-	-	95.38	27.31	6.04	36.46	150	350	A	H
		2389.38	64.32	-9.68	74	67.49	27.25	6.04	36.46	150	78	P	V
		2389.92	46.38	-7.62	54	49.55	27.25	6.04	36.46	150	78	A	V
	*	2412	107.45	-	-	110.56	27.31	6.04	36.46	150	78	P	V
	*	2412	96.22	-	-	99.33	27.31	6.04	36.46	150	78	A	V
802.11g CH 06 2437MHz		2385.15	51.65	-22.35	74	54.88	27.19	6.04	36.46	150	350	P	H
		2384.7	40.33	-13.67	54	43.56	27.19	6.04	36.46	150	350	A	H
	*	2437	103.63	-	-	106.57	27.42	6.09	36.45	150	350	P	H
	*	2437	92.61	-	-	95.55	27.42	6.09	36.45	150	350	A	H
		2489.32	54.86	-19.14	74	57.54	27.6	6.17	36.45	150	350	P	H
		2489.36	43.36	-10.64	54	46.04	27.6	6.17	36.45	150	350	A	H
		2384.16	55.65	-18.35	74	58.88	27.19	6.04	36.46	150	78	P	V
		2384.7	44.93	-9.07	54	48.16	27.19	6.04	36.46	150	78	A	V
	*	2437	107.44	-	-	110.38	27.42	6.09	36.45	150	78	P	V
	*	2437	96.72	-	-	99.66	27.42	6.09	36.45	150	78	A	V
		2489.68	60.15	-13.85	74	62.83	27.6	6.17	36.45	150	78	P	V
		2489.2	49.04	-4.96	54	51.72	27.6	6.17	36.45	150	78	A	V



<b>802.11g CH 11 2462MHz</b>	*	2462	104.45	-	-	107.29	27.48	6.13	36.45	150	350	P	H
	*	2462	92.8	-	-	95.64	27.48	6.13	36.45	150	350	A	H
		2483.56	63.99	-10.01	74	66.73	27.54	6.17	36.45	150	350	P	H
		2483.56	43.55	-10.45	54	46.29	27.54	6.17	36.45	150	350	A	H
	*	2462	108.48	-	-	111.32	27.48	6.13	36.45	150	79	P	V
	*	2462	97.06	-	-	99.9	27.48	6.13	36.45	150	79	A	V
		2483.52	69.63	-4.37	74	72.37	27.54	6.17	36.45	150	79	P	V
		2483.52	50.42	-3.58	54	53.16	27.54	6.17	36.45	150	79	A	V
<b>Remark</b>	1. No other spurious found. 2. All results are PASS against Peak and Average limit line.												





**2.4GHz 2400~2483.5MHz**  
**WIFI 802.11g (Harmonic @ 3m)**

WIFI Ant. 1	Note	Frequency ( MHz )	Level ( dBμV/m )	Over Limit ( dB )	Limit Line ( dBμV/m )	Read Level ( dBμV )	Antenna Factor ( dB/m )	Cable Loss ( dB )	Preamp Factor ( dB )	Ant Pos ( cm )	Table Pos ( deg )	Peak Avg. (P/A)	Pol. (H/V)
802.11g CH 01 2412MHz		4824	44.77	-29.23	74	41.22	31.26	8.23	35.94	105	198	P	H
		4824	45.38	-28.62	74	41.83	31.26	8.23	35.94	105	198	P	V
802.11g CH 06 2437MHz		4874	45.03	-28.97	74	41.3	31.36	8.29	35.92	145	265	P	H
		7311	50.26	-23.74	74	40.54	35.96	10.29	36.53	174	321	P	H
		4874	44.96	-29.04	74	41.23	31.36	8.29	35.92	145	265	P	V
		7311	49.87	-24.13	74	40.15	35.96	10.29	36.53	174	321	P	V
802.11g CH 11 2462MHz		4924	45.1	-28.9	74	41.22	31.46	8.32	35.9	146	347	P	H
		7386	49.42	-24.58	74	39.59	36.08	10.34	36.59	145	274	P	H
		4924	45.68	-28.32	74	41.8	31.46	8.32	35.9	146	347	P	V
		7386	49.29	-24.71	74	39.46	36.08	10.34	36.59	145	274	P	V
Remark	1. No other spurious found. 2. All results are PASS against Peak and Average limit line.												



**2.4GHz 2400~2483.5MHz  
WIFI 802.11n HT20 (Band Edge @ 3m)**

WIFI Ant. 1	Note	Frequency ( MHz )	Level ( dBμV/m )	Over Limit ( dB )	Limit Line ( dBμV/m )	Read Level ( dBμV )	Antenna Factor ( dB/m )	Cable Loss ( dB )	Preamp Factor ( dB )	Ant Pos ( cm )	Table Pos ( deg )	Peak Avg. ( P/A )	Pol. ( H/V )
802.11n HT20 CH 01 2412MHz		2389.11	59.44	-14.56	74	62.61	27.25	6.04	36.46	150	349	P	H
		2389.92	41.06	-12.94	54	44.23	27.25	6.04	36.46	150	349	A	H
	*	2412	100.91	-	-	104.02	27.31	6.04	36.46	150	349	P	H
	*	2412	90.69	-	-	93.8	27.31	6.04	36.46	150	349	A	H
		2389.29	64.32	-9.68	74	67.49	27.25	6.04	36.46	150	78	P	V
		2389.92	45.33	-8.67	54	48.5	27.25	6.04	36.46	150	78	A	V
	*	2412	104.41	-	-	107.52	27.31	6.04	36.46	150	78	P	V
	*	2412	94.19	-	-	97.3	27.31	6.04	36.46	150	78	A	V
802.11n HT20 CH 06 2437MHz		2384.79	50.86	-23.14	74	54.09	27.19	6.04	36.46	150	350	P	H
		2385.24	39.47	-14.53	54	42.7	27.19	6.04	36.46	150	350	A	H
	*	2437	100.88	-	-	103.82	27.42	6.09	36.45	150	350	P	H
	*	2437	90.53	-	-	93.47	27.42	6.09	36.45	150	350	A	H
		2489.4	53.3	-20.7	74	55.98	27.6	6.17	36.45	150	350	P	H
		2488.68	41.9	-12.1	54	44.58	27.6	6.17	36.45	150	350	A	H
		2385.33	55	-19	74	58.23	27.19	6.04	36.46	150	78	P	V
		2385.06	43.92	-10.08	54	47.15	27.19	6.04	36.46	150	78	A	V
	*	2437	105	-	-	107.94	27.42	6.09	36.45	150	78	P	V
	*	2437	94.71	-	-	97.65	27.42	6.09	36.45	150	78	A	V
		2489.04	59.12	-14.88	74	61.8	27.6	6.17	36.45	150	78	P	V
	2488.72	47.92	-6.08	54	50.6	27.6	6.17	36.45	150	78	A	V	



802.11n HT20 CH 11 2462MHz	*	2462	100.96	-	-	103.8	27.48	6.13	36.45	150	350	P	H
	*	2462	90.61	-	-	93.45	27.48	6.13	36.45	150	350	A	H
		2486.6	59.97	-14.03	74	62.71	27.54	6.17	36.45	150	350	P	H
		2483.56	41.49	-12.51	54	44.23	27.54	6.17	36.45	150	350	A	H
	*	2462	105.29	-	-	108.13	27.48	6.13	36.45	150	78	P	V
	*	2462	94.95	-	-	97.79	27.48	6.13	36.45	150	78	A	V
		2484.88	70.77	-3.23	74	73.51	27.54	6.17	36.45	150	78	P	V
	2483.6	48.32	-5.68	54	51.06	27.54	6.17	36.45	150	78	A	V	
Remark	1. No other spurious found. 2. All results are PASS against Peak and Average limit line.												



**2.4GHz 2400~2483.5MHz**  
**WIFI 802.11n HT20 (Harmonic @ 3m)**

WIFI Ant. 1	Note	Frequency ( MHz )	Level ( dBμV/m )	Over Limit ( dB )	Limit Line ( dBμV/m )	Read Level ( dBμV )	Antenna Factor ( dB/m )	Cable Loss ( dB )	Preamp Factor ( dB )	Ant Pos ( cm )	Table Pos ( deg )	Peak Avg. (P/A)	Pol. (H/V)
802.11n HT20 CH 01 2412MHz		4824	45.37	-28.63	74	41.82	31.26	8.23	35.94	105	198	P	H
		4824	45.11	-28.89	74	41.56	31.26	8.23	35.94	105	198	P	V
802.11n HT20 CH 06 2437MHz		4874	45.74	-28.26	74	42.01	31.36	8.29	35.92	145	265	P	H
		7311	49.53	-24.47	74	39.81	35.96	10.29	36.53	174	321	P	H
		4874	44.82	-29.18	74	41.09	31.36	8.29	35.92	145	265	P	V
		7311	50.28	-23.72	74	40.56	35.96	10.29	36.53	174	321	P	V
802.11n HT20 CH 11 2462MHz		4924	44.5	-29.5	74	40.62	31.46	8.32	35.9	146	347	P	H
		7386	49.52	-24.48	74	39.69	36.08	10.34	36.59	145	274	P	H
		4924	44.88	-29.12	74	41	31.46	8.32	35.9	146	347	P	V
		7386	49.45	-24.55	74	39.62	36.08	10.34	36.59	145	274	P	V
Remark	1. No other spurious found. 2. All results are PASS against Peak and Average limit line.												



**2.4GHz 2400~2483.5MHz  
WIFI 802.11n HT40 (Band Edge @ 3m)**

WIFI Ant. 1	Note	Frequency ( MHz )	Level ( dBμV/m )	Over Limit ( dB )	Limit Line ( dBμV/m )	Read Level ( dBμV )	Antenna Factor ( dB/m )	Cable Loss ( dB )	Preamp Factor ( dB )	Ant Pos ( cm )	Table Pos ( deg )	Peak Avg. ( P/A )	Pol. ( H/V )
802.11n HT40 CH 03 2422MHz		2389.56	60.55	-13.45	74	63.72	27.25	6.04	36.46	150	348	P	H
		2389.83	44.11	-9.89	54	47.28	27.25	6.04	36.46	150	348	A	H
	*	2422	96.01	-	-	99	27.37	6.09	36.45	150	348	P	H
	*	2422	86.27	-	-	89.26	27.37	6.09	36.45	150	348	A	H
		2484.4	45.85	-28.15	74	48.59	27.54	6.17	36.45	150	348	P	H
		2486.04	33.53	-20.47	54	36.27	27.54	6.17	36.45	150	348	A	H
		2387.76	64.44	-9.56	74	67.61	27.25	6.04	36.46	150	78	P	V
		2389.74	48.13	-5.87	54	51.3	27.25	6.04	36.46	150	78	A	V
	*	2422	99.52	-	-	102.51	27.37	6.09	36.45	150	78	P	V
	*	2422	89.57	-	-	92.56	27.37	6.09	36.45	150	78	A	V
		2490.88	51.93	-22.07	74	54.61	27.6	6.17	36.45	150	78	P	V
		2485.68	39.99	-14.01	54	42.73	27.54	6.17	36.45	150	78	A	V
802.11n HT40 CH 06 2437MHz		2389.83	51.62	-22.38	74	54.79	27.25	6.04	36.46	150	350	P	H
		2334.21	36.32	-17.68	54	39.82	27.01	5.96	36.47	150	350	A	H
	*	2437	96.92	-	-	99.86	27.42	6.09	36.45	150	350	P	H
	*	2437	86.68	-	-	89.62	27.42	6.09	36.45	150	350	A	H
		2483.88	51.06	-22.94	74	53.8	27.54	6.17	36.45	150	350	P	H
		2483.64	36.62	-17.38	54	39.36	27.54	6.17	36.45	150	350	A	H
		2389.92	55.72	-18.28	74	58.89	27.25	6.04	36.46	150	78	P	V
		2389.92	39.8	-14.2	54	42.97	27.25	6.04	36.46	150	78	A	V
	*	2437	99.77	-	-	102.71	27.42	6.09	36.45	150	78	P	V
	*	2437	90.19	-	-	93.13	27.42	6.09	36.45	150	78	A	V
	2484.2	57.49	-16.51	74	60.23	27.54	6.17	36.45	150	78	P	V	
	2483.68	42.21	-11.79	54	44.95	27.54	6.17	36.45	150	78	A	V	



802.11n HT40 CH 09 2452MHz		2348.43	47.35	-26.65	74	50.78	27.07	5.96	36.46	150	350	P	H
		2348.43	36.1	-17.9	54	39.53	27.07	5.96	36.46	150	350	A	H
	*	2452	96.08	-	-	98.98	27.42	6.13	36.45	150	350	P	H
	*	2452	86.46	-	-	89.36	27.42	6.13	36.45	150	350	A	H
		2483.96	59.93	-14.07	74	62.67	27.54	6.17	36.45	150	350	P	H
		2483.84	43.16	-10.84	54	45.9	27.54	6.17	36.45	150	350	A	H
		2348.07	49.23	-24.77	74	52.66	27.07	5.96	36.46	150	78	P	V
		2349.24	38.13	-15.87	54	41.56	27.07	5.96	36.46	150	78	A	V
	*	2452	99.91	-	-	102.81	27.42	6.13	36.45	150	78	P	V
	*	2452	90.19	-	-	93.09	27.42	6.13	36.45	150	78	A	V
		2484.44	67.69	-6.31	74	70.43	27.54	6.17	36.45	150	78	P	V
		2483.8	50	-4	54	52.74	27.54	6.17	36.45	150	78	A	V
Remark	1. No other spurious found. 2. All results are PASS against Peak and Average limit line.												



**2.4GHz 2400~2483.5MHz  
WIFI 802.11n HT40 (Harmonic @ 3m)**

WIFI Ant. 1	Note	Frequency ( MHz )	Level ( dBμV/m )	Over Limit ( dB )	Limit Line ( dBμV/m )	Read Level ( dBμV )	Antenna Factor ( dB/m )	Cable Loss ( dB )	Preamp Factor ( dB )	Ant Pos ( cm )	Table Pos ( deg )	Peak Avg. (P/A)	Pol. (H/V)
802.11n		4844	45.34	-28.66	74	41.72	31.29	8.26	35.93	126	248	P	H
HT40		7266	50.4	-23.6	74	40.76	35.91	10.24	36.51	185	252	P	H
CH 03		4844	45.2	-28.8	74	41.58	31.29	8.26	35.93	126	248	P	V
2422MHz		7266	50.47	-23.53	74	40.83	35.91	10.24	36.51	185	252	P	V
802.11n		4874	44.78	-29.22	74	41.05	31.36	8.29	35.92	132	224	P	H
HT40		7311	50.46	-23.54	74	40.74	35.96	10.29	36.53	119	347	P	H
CH 06		4874	45.16	-28.84	74	41.43	31.36	8.29	35.92	132	224	P	V
2437MHz		7311	49.71	-24.29	74	39.99	35.96	10.29	36.53	119	347	P	V
802.11n		4904	45.62	-28.38	74	41.78	31.43	8.32	35.91	125	214	P	H
HT40		7356	49.97	-24.03	74	40.2	36.03	10.31	36.57	127	315	P	H
CH 09		4904	46.02	-27.98	74	42.18	31.43	8.32	35.91	125	214	P	V
2452MHz		7356	50.11	-23.89	74	40.34	36.03	10.31	36.57	127	315	P	V
Remark	1. No other spurious found. 2. All results are PASS against Peak and Average limit line.												



Emission below 1GHz  
2.4GHz WIFI 802.11n HT20 (LF)

WIFI	Note	Frequency	Level	Over	Limit	Read	Antenna	Cable	Preamp	Ant	Table	Peak	Pol.
Ant.				Limit	Line	Level	Factor	Loss	Factor	Pos	Pos	Avg.	
1		( MHz )	( dBμV/m )	( dB )	( dBμV/m )	( dBμV )	( dB/m )	( dB )	( dB )	( cm )	( deg )	( P/A )	( H/V )
2.4GHz 802.11n HT20 LF		134.76	36.87	-6.63	43.5	53.17	12.45	1.74	30.49	157	265	P	H
		210.42	28.37	-15.13	43.5	46.45	10.33	2	30.41			P	H
		273.47	33.12	-12.88	46	47.42	13.67	2.35	30.32			P	H
		507.24	23.67	-22.33	46	32.73	17.98	2.89	29.93			P	H
		583.87	22.87	-23.13	46	30.56	18.94	3.17	29.8			P	H
		979.63	23.38	-30.62	54	26.17	22.36	3.95	29.1			P	H
		62.98	35.02	-4.98	40	59.79	6.45	1.33	30.55	192	260	P	V
		148.34	33.94	-9.56	43.5	50.42	12.14	1.85	30.47			P	V
		276.38	30.18	-15.82	46	44.34	13.8	2.35	30.31			P	V
		422.85	20.23	-25.77	46	31.26	16.27	2.78	30.08			P	V
		615.88	21.19	-24.81	46	28.3	19.33	3.31	29.75			P	V
	880.69	22.6	-23.4	46	26.21	21.85	3.81	29.27			P	V	
Remark	1. No other spurious found. 2. All results are PASS against limit line.												





**Note symbol**

*	<b>Fundamental Frequency</b> which can be ignored. However, the level of any unwanted emissions shall not exceed the level of the fundamental frequency.
!	Test result is <b>over limit</b> line.
P/A	<b>Peak</b> or <b>Average</b>
H/V	<b>Horizontal</b> or <b>Vertical</b>



A calculation example for radiated spurious emission is shown as below:

WIFI	Note	Frequency	Level	Over	Limit	Read	Antenna	Cable	Preamp	Ant	Table	Peak	Pol.
Ant.				Limit	Line	Level	Factor	Loss	Factor	Pos	Pos	Avg.	
1		( MHz )	( dBμV/m )	( dB )	( dBμV/m )	( dBμV )	( dB/m )	( dB )	( dB )	( cm )	( deg )	( P/A )	( H/V )
802.11b		2390	55.45	-18.55	74	54.51	32.22	4.58	35.86	103	308	P	H
CH 01													
2412MHz		2390	43.54	-10.46	54	42.6	32.22	4.58	35.86	103	308	A	H

- Level(dBμV/m) =  
Antenna Factor(dB/m) + Cable Loss(dB) + Read Level(dBμV) - Preamp Factor(dB)
- Over Limit(dB) = Level(dBμV/m) – Limit Line(dBμV/m)

**For Peak Limit @ 2390MHz:**

- Level(dBμV/m)  
= Antenna Factor(dB/m) + Cable Loss(dB) + Read Level(dBμV) - Preamp Factor(dB)  
= 32.22(dB/m) + 4.58(dB) + 54.51(dBμV) – 35.86 (dB)  
= 55.45 (dBμV/m)
- Over Limit(dB)  
= Level(dBμV/m) – Limit Line(dBμV/m)  
= 55.45(dBμV/m) – 74(dBμV/m)  
= -18.55(dB)

**For Average Limit @ 2390MHz:**

- Level(dBμV/m)  
= Antenna Factor(dB/m) + Cable Loss(dB) + Read Level(dBμV) - Preamp Factor(dB)  
= 32.22(dB/m) + 4.58(dB) + 42.6(dBμV) – 35.86 (dB)  
= 43.54 (dBμV/m)
- Over Limit(dB)  
= Level(dBμV/m) – Limit Line(dBμV/m)  
= 43.54(dBμV/m) – 54(dBμV/m)  
= -10.46(dB)

Both peak and average measured complies with the limit line, so test result is “PASS”.