

FCC SAR Test Report (Class II Permissive Change)

Product Name : 7c Modular Platform

Model No. : QSIP7180

Applicant : ELITEGROUP COMPUTER SYSTEMS CO., LTD

Address : No.239,Sec.2,Ti Ding Blvd., Taipei, Taiwan

Date of Receipt : 2022/01/20

Issued Date : 2022/04/27

Report No. : 2210618R-SAUSSARV02-B

Report Version : V2.0



The test results relate only to the samples tested.

The test results shown in the test report are traceable to the national/international standard through the calibration report of the equipment and evaluated measurement uncertainty herein.

This report must not be used to claim product endorsement by TAF or any agency of the government.

The test report shall not be reproduced without the written approval of DEKRA Testing and Certification Co., Ltd.

Measurement uncertainties evaluated for each testing system and associated connections are given here to provide the system information for reference. Compliance determinations do not take into account measurement uncertainties for each testing system, but are based on the results of the compliance measurement.

Test Report

Issued Date: 2022/04/27

Report No.: 2210618R-SAUSSARV02-B



Product Name : 7c Modular Platform
 Applicant : ELITEGROUP COMPUTER SYSTEMS CO., LTD
 Address : No.239,Sec.2,Ti Ding Blvd., Taipei, Taiwan
 Manufacturer : ELITEGROUP COMPUTER SYSTEMS CO., LTD
 Model No. : QSIP7180
 Trade Name : ECS ELITGROUP
 FCC ID : WL6-718020QT1C
 Applicable Standard : IEEE 1528-2013
 KDB 447498 D01 v06
 KDB 865664 D01 v01r04
 Measurement : 47CFR § 2.1093
 Procedures : KDB 248227 D01 v02r02
 KDB 616217 D04 v01r02
 KDB 941225 D01 v03r01
 KDB 941225 D05 v02r05
 KDB 941225 D05A v01r02
 Test Result : Max. SAR Measurement (1g)
 WLAN: **0.097** W/kg
 WWAN: **1.142** W/kg
 Application Type : Certification

The above equipment has been tested by DEKRA, and found compliance with the requirement of the above standards. The test record, data evaluation & Equipment Under Test (EUT) configurations represented herein are true and accurate accounts of the measurements of the sample's SAR characteristics under the conditions specified in this report.

Documented By : Jinn Chen
 (Supervisor / Jinn Chen)

Tested By : Luke Cheng
 (Senior Engineer / Luke Cheng)

Approved By : San Lin
 (Supervisor / San Lin)

TABLE OF CONTENTS

Description	Page
1. General Information.....	5
1.1 EUT Description	5
1.2 Antenna List	6
1.3 SAR Test Position	7
1.4 Test Environment	8
2. SAR Measurement System	9
2.1 DASY5 System Description	9
2.1.1 Applications	10
2.1.2 Area Scans	10
2.1.3 Zoom Scan (Cube Scan Averaging)	10
2.1.4 Uncertainty of Inter-/Extrapolation and Averaging	10
2.2 DASY5 E-Field Probe	11
2.2.1 Isotropic E-Field Probe Specification	11
2.3 Boundary Detection Unit and Probe Mounting Device	12
2.4 DATA Acquisition Electronics (DAE) and Measurement Server	12
2.5 Robot	13
2.6 Light Beam Unit	13
2.7 Device Holder	14
2.8 SAM Twin Phantom	14
3. Tissue Simulating Liquid	15
3.1 The composition of the tissue simulating liquid	15
3.2 Tissue Calibration Result	15
3.3 Tissue Dielectric Parameters for Head and Body Phantoms	22
4. SAR Measurement Procedure	23
4.1 SAR System Check	23
4.1.1 Dipoles	23
4.1.2 System Check Result	24
4.2 SAR Measurement Procedure	27
5. SAR Exposure Limits	28
6. Test Equipment List.....	29
7. Measurement Uncertainty	30
8. Conducted Power Measurement (Including tolerance allowed for production unit)	32
9. Proximity Sensor	107
9.1 proximity sensor triggering distances	107
9.2 Procedures for determining antenna and proximity sensor coverage	108
9.3. Summary of Trigger Distance	109
10. Test Results.....	111
10.1 SAR Test Results Summary.....	111
10.2 Simultaneous Transmission.....	132
10.2.1 Simultaneous transmission of MIMO in 802.11 test exclusion considerations	133
10.2.2 Simultaneous transmission of Wi-Fi and other wireless technologies	133
11. SAR measurement variability	134
Appendix	
Appendix A. SAR System Check Data	
Appendix B. SAR measurement Data	
Appendix C. Test Setup Photographs	
Appendix D. Probe Calibration Data	
Appendix E. Dipole Calibration Data	
Appendix F. Product Photos-Please refer to the file: 2210618R-Product Photos	

Revision History

Report No.	Version	Description	Issued Date
2210618R-SAUSSARV02-B	V1.0	Initial issue of report.	2022/04/12
2210618R-SAUSSARV02-B	V2.0	Corrected typo in Section 6.	2022/04/27

1. General Information

1.1 EUT Description

Product Name	7c Modular Platform			
Trade Name	ECS ELITGROUP			
Model No.	QSIP7180			
FCC ID	WL6-718020QT1C			
Frequency Range (Licensed)	WCDMA Band 2/LTE Band 2: 1850-1910MHz WCDMA Band 5/LTE Band 5: 824-849MHz LTE Band 4: 1710-1755MHz LTE Band 7: 2500-2570MHz, LTE Band 12: 699-716MHz LTE Band 13: 777-787MHz, LTE Band 14: 788-798MHz LTE Band 17: 704-716MHz, LTE Band 25: 1850-1915MHz LTE Band 26: 814-849MHz, LTE Band 30: 2305-2315MHz LTE Band 38: 2570-2620MHz, LTE Band 41: 2496-2690MHz LTE Band 66: 1710-1780MHz, LTE Band 71: 663-698MHz			
Frequency Range	802.11b/g/n-20MHz: 2412-2472MHz 802.11n-40MHz: 2422-2462MHz 802.11a/n-20/ac-20: 5180-5320MHz, 5500-5720MHz, 5745-5825MHz 802.11n-40/ac-40MHz: 5190-5310MHz, 5510-5710MHz, 5755-5795MHz 802.11ac-80MHz: 5210-5290MHz, 5530-5690MHz, 5775MHz BT: 2402-2480MHz			
Type of Modulation	802.11b: DSSS 802.11a/g/n/ac: OFDM GFSK(1Mbps) /π/4DQPSK(2Mbps) / 8DPSK(3Mbps) WCDMA: RMC 12.2Kbps/HSDPA/HSUPA, LTE: QPSK/16QAM/64QAM			
Device Category	Portable			
RF Exposure Environment	Uncontrolled			
Summary of test result – Reported Body 1g SAR (W/Kg)				
Test configuration	Licensed	DTS	NII	DSS(BT)
Standalone	1.142	0.026	0.097	0.015
Simultaneous	1.326	1.181	1.326	1.326

Note:

Host information		
Manufacturer	Product Name	Model No.
ELITEGROUP COMPUTER SYSTEMS CO., LTD	Notebook Computer	SG20QT1C

1.2 Antenna List

No.	Manufacturer	Part No.	Antenna Type	Peak Gain
1	WGT (WLAN)	EGSG2WRPB01+A(Main)	PIFA	2.75dBi for 2.4GHz 2.54dBi for 5.15~5.25GHz 2.54dBi for 5.25~5.35GHz 2.99dBi for 5.47~5.725GHz 3.16dBi for 5.725~5.850GHz
		EGSG2WRPB02+A(Aux)	PIFA	2.81dBi for 2.4GHz 2.74dBi for 5.15~5.25GHz 2.74dBi for 5.25~5.35GHz 2.17dBi for 5.47~5.725GHz 1.48dBi for 5.725~5.850GHz
2	SPEED (WLAN)	F-0G-MA-6001-003-00(Main)	PIFA	0.58dBi for 2.4GHz -0.31dBi for 5.15~5.25GHz 1.56dBi for 5.25~5.35GHz -0.69dBi for 5.47~5.725GHz -0.69dBi for 5.725~5.850GHz
		F-0G-MA-6001-004-00(Aux)	PIFA	1.75dBi for 2.4GHz 0.49dBi for 5.15~5.25GHz 0.87dBi for 5.25~5.35GHz 0.08dBi for 5.47~5.725GHz 1.29dBi for 5.725~5.850GHz
3	SPEED (WWAN)	F-0G-MA-6001-001-00(Main)	PIFA	0.53dBi for 663-698MHz 0.67dBi for 699-716MHz 3.44dBi for 777-787MHz 3.44dBi for 788-798MHz 2.24dBi for 814-849MHz 0.73dBi for 1710-1785MHz 0.71dBi for 1850-1915MHz 1.31dBi for 2305-2315MHz 2.44dBi for 2496-2690MHz
		F-0G-MA-6001-002-00(Aux)	PIFA	0.3dBi for 663-698MHz 0.3dBi for 699-716MHz 2.99dBi for 777-787MHz 2.99dBi for 788-798MHz 2.99dBi for 814-849MHz 1.12dBi for 1710-1785MHz 0.76dBi for 1850-1915MHz 0.42dBi for 2305-2315MHz 2.97dBi for 2496-2690MHz

1.3 SAR Test Position

According to KDB Publication 616217 D04, SAR evaluation is required for the bottom surface of the laptop keyboard.

TX Antenna	Separation distances (mm)
	Bottom
WLAN Main	195.65
WLAN Aux	195.65
WWAN Main	4

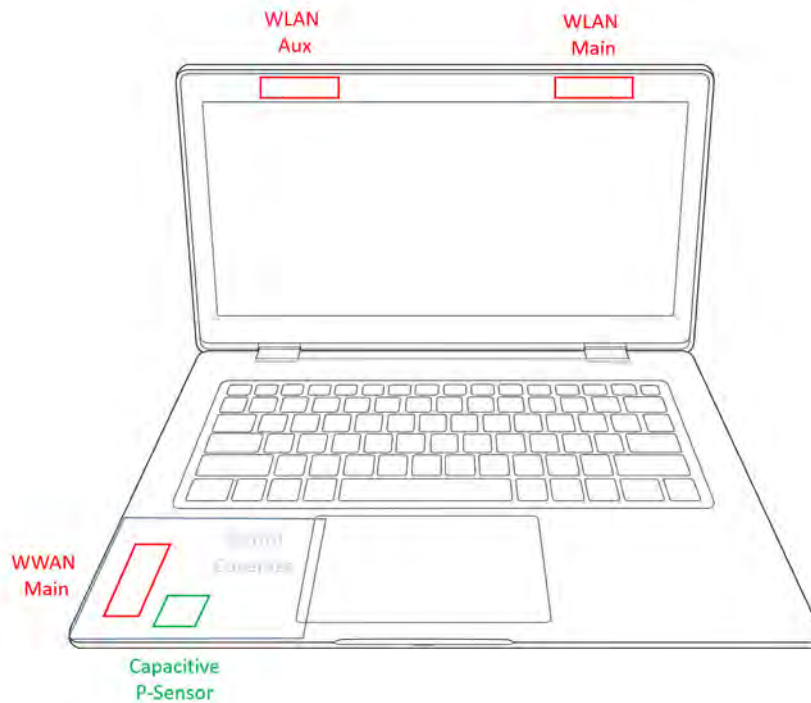

1.4 Test Environment

Ambient conditions in the laboratory:

Test Date: 2022/2/16– 2022/3/11

Items	Required	Actual
Temperature (°C)	18-25	23 ±2
Humidity (%RH)	30-70	50 ±20

USA : **FCC Registration Number: TW0033**

Canada : **IC Registration Number: 26930**

Site Description : Accredited by TAF
Accredited Number: 3023

Test Laboratory : DEKRA Testing and Certification Co., Ltd
Address : No. 26, Huaya 1st Rd., Guishan Dist.,
Taoyuan City 333411, Taiwan, R.O.C.

Phone number : 886-3-275-7255

Fax number : 866-3-327-8031

Email address : info.tw@dekra.com

Website : <http://www.dekra.com.tw>

2. SAR Measurement System

2.1 DASY5 System Description

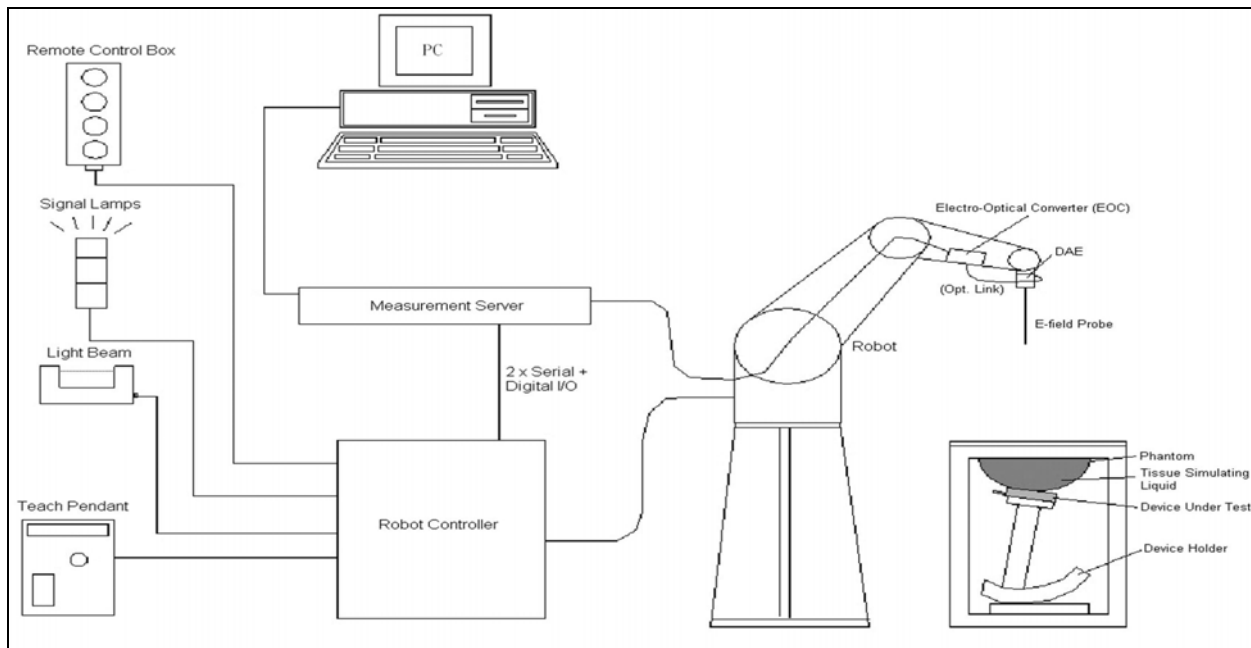

The DASY5 system for performing compliance tests consists of the following items:

- A standard high precision 6-axis robot with controller, teach pendant and software. An arm extension for accommodating the data acquisition electronics (DAE).
- A data acquisition electronics (DAE) which performs the signal amplification, signal multiplexing, AD-conversion, offset measurements, mechanical surface detection, collision detection, etc. The unit is battery powered with standard or rechargeable batteries. The signal is optically transmitted to the EOC.
- The Electro-optical converter (EOC) performs the conversion from optical to electrical signals for the digital communication to the DAE. To use optical surface detection, a special version of the EOC is required. The EOC signal is transmitted to the measurement server.
- The Light Beam used is for probe alignment. This improves the (absolute) accuracy of the probe positioning.
- A computer running WinXP and the DASY5 software.
- Remote control and teach pendant as well as additional circuitry for robot safety such as warning lamps, etc.
- The phantom, the device holder and other accessories according to the targeted measurement.

2.1.1 Applications

Predefined procedures and evaluations for automated compliance testing with all worldwide standards, e.g., IEEE 1528, OET 65, IEC 62209-1, IEC 62209-2, EN 50360, EN 50383 and others.

2.1.2 Area Scans

Area scans are defined prior to the measurement process being executed with a user defined variable spacing between each measurement point (integral) allowing low uncertainty measurements to be conducted. Scans defined for FCC applications utilize a 10mm² step integral, with 1mm interpolation used to locate the peak SAR area used for zoom scan assessments.

When an Area Scan has measured all reachable points, it computes the field maxima found in the scanned area, within a range of the global maximum. The range (in dB) is specified in the standards for compliance testing. For example, a 2 dB range is required in IEEE 1528-2013, EN 50361 and IEC 62209 standards, whereby 3 dB is a requirement when compliance is assessed in accordance with the ARIB standard (Japan).

2.1.3 Zoom Scan (Cube Scan Averaging)

Zoom Scans are used to assess the peak spatial SAR values within a cubic averaging volume containing 1 g and 10 g of simulated tissue. A density of 1000 kg/m³ is used to represent the head and body tissue density and not the phantom liquid density, in order to be consistent with the definition of the liquid dielectric properties, i.e. the side length of the 1 g cube is 10mm, with the side length of the 10 g cube 21,5mm.

The zoom scan integer steps can be user defined so as to reduce uncertainty, but normal practice for typical test applications (including FCC) utilize a physical step of 5x5x7 (8mmx8mmx5mm) providing a volume of 32mm in the X & Y axis, and 30mm in the Z axis.

2.1.4 Uncertainty of Inter-/Extrapolation and Averaging

In order to evaluate the uncertainty of the interpolation, extrapolation and averaged SAR calculation algorithms of the Postprocessor, DASYS5 allows the generation of measurement grids which are artificially predefined by analytically based test functions. Therefore, the grids of area scans and zoom scans can be filled with uncertainty test data, according to the SAR benchmark functions of IEEE 1528. The three analytical functions shown in equations as below are used to describe the possible range of the expected SAR

distributions for the tested handsets. The field gradients are covered by the spatially flat distribution f1, the spatially steep distribution f3 and f2 accounts for H-field cancellation on the phantom/tissue surface.

$$f_1(x, y, z) = Ae^{-\frac{z}{2a}} \cos^2 \left(\frac{\pi \sqrt{x'^2 + y'^2}}{2 \cdot 5a} \right)$$

$$f_2(x, y, z) = Ae^{-\frac{z}{a}} \frac{a^2}{a^2 + x'^2} \left(3 - e^{-\frac{2z}{a}} \right) \cos^2 \left(\frac{\pi y'}{2 \cdot 3a} \right)$$

$$f_3(x, y, z) = A \frac{a^2}{\frac{a^2}{4} + x'^2 + y'^2} \left(e^{-\frac{2z}{a}} + \frac{a^2}{2(a + 2z)^2} \right)$$

2.2 DASYS E-Field Probe

The SAR measurement is conducted with the dosimetric probe manufactured by SPEAG. The probe is specially designed and calibrated for use in liquid with high permittivity. The dosimetric probe has special calibration in liquid at different frequency.

SPEAG conducts the probe calibration in compliance with international and national standards (e.g. IEEE 1528, EN 62209-1, IEC 62209, etc.) under ISO 17025. The calibration data are in Appendix D.

2.2.1 Isotropic E-Field Probe Specification

Model	Ex3DV4	
Construction	Symmetrical design with triangular core Built-in shielding against static charges PEEK enclosure material (resistant to organic solvents, e.g., DGBE)	
Frequency	10 MHz to 6 GHz Linearity: ± 0.2 dB (30 MHz to 6 GHz)	
Directivity	± 0.3 dB in HSL (rotation around probe axis) ± 0.5 dB in tissue material (rotation normal to probe axis)	
Dynamic Range	10 μ W/g to 100 mW/g Linearity: ± 0.2 dB (noise: typically < 1 μ W/g)	
Dimensions	Overall length: 330 mm (Tip: 20 mm) Tip diameter: 2.5 mm (Body: 12 mm) Typical distance from probe tip to dipole centers: 1 mm	
Application	High precision dosimetric measurements in any exposure scenario (e.g., very strong gradient fields). Only probe which enables compliance testing for frequencies up to 6 GHz with precision of better 30%.	

2.3 Boundary Detection Unit and Probe Mounting Device

The DASY probes use a precise connector and an additional holder for the probe, consisting of a plastic tube and a flexible silicon ring to center the probe. The connector at the DAE is flexibly mounted and held in the default position with magnets and springs. Two switching systems in the connector mount detect frontal and lateral probe collisions and trigger the necessary software response.

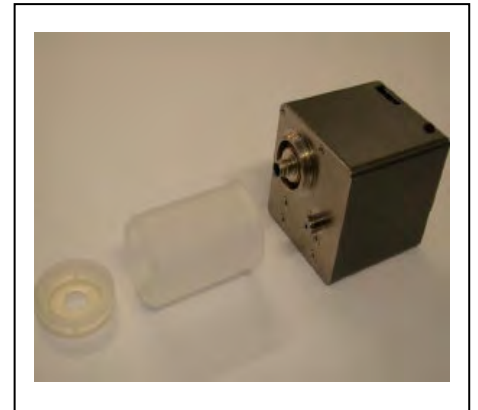

2.4 DATA Acquisition Electronics (DAE) and Measurement Server

The data acquisition electronics (DAE) consists of a highly sensitive electrometer-grade preamplifier with auto-zeroing, a channel and gain-switching multiplexer, a fast 16 bit AD-converter and a command decoder and control logic unit.

Transmission to the measurement server is accomplished through an optical downlink for data and status information as well as an optical uplink for commands and the clock.

The input impedance of the DAE4 is 200M Ohm; the inputs are symmetrical and floating. Common mode rejection is above 80dB.



The DASY5 measurement server is based on a PC/104 CPU board with a 400MHz intel ULV Celeron, 128MB chipdisk and 128MB RAM. The necessary circuits for communication with the DAE electronics box, as well as the 16 bit AD converter system for optical detection and digital I/O interface are contained on the DASY5 I/O board, which is directly connected to the PC/104 bus of the CPU board.



2.5 Robot

The DASY5 system uses the high precision robots TX90 XL type out of the newer series from Stäubli SA (France). For the 6-axis controller DASY5 system, the CS8C robot controller version from Stäubli is used.

The XL robot series have many features that are important for our application:

- High precision (repeatability 0.02 mm)
- High reliability (industrial design)
- Jerk-free straight movements
- Low ELF interference (the closed metallic construction shields against motor control fields)
- 6-axis controller



2.6 Light Beam Unit

The light beam switch allows automatic "tooling" of the probe. During the process, the actual position of the probe tip with respect to the robot arm is measured, as well as the probe length and the horizontal probe offset. The software then corrects all movements, such that the robot coordinates are valid for the probe tip.

The repeatability of this process is better than 0.1 mm. If a position has been taught with an aligned probe, the same position will be reached with another aligned probe within 0.1 mm, even if the other probe has different dimensions. During probe rotations, the probe tip will keep its actual position.



2.7 Device Holder

The DASY5 device holder is designed to cope with different positions given in the standard. It has two scales for the device rotation (with respect to the body axis) and the device inclination (with respect to the line between the ear reference points). The rotation center for both scales is the ear reference point (EPR).

Thus the device needs no repositioning when changing the angles.

The DASY5 device holder has been made out of low-loss POM material having the following dielectric parameters: relative permittivity $\epsilon_r = 3$ and loss tangent $\delta = 0.02$. The amount of dielectric material has been reduced in the closest vicinity of the device, since measurements have suggested that the influence of the clamp on the test results could thus be lowered.



2.8 SAM Twin Phantom

The SAM twin phantom is a fiberglass shell phantom with 2mm shell thickness (except the ear region where shell thickness increases to 6mm). It has three measurement areas:

- Left head
- Right head
- Flat phantom



The bottom plate contains three pair of bolts for locking the device holder. The device holder positions are adjusted to the standard measurement positions in the three sections. A white cover is provided to tap the phantom during off-periods to prevent water evaporation and changes in the liquid parameters. On the phantom top, three reference markers are provided to identify the phantom position with respect to the robot.

3. Tissue Simulating Liquid

3.1 The composition of the tissue simulating liquid

The following tissue formulation is for reference only. The composition of the ingredients may be modified accordingly to achieve the target tissue parameters required for routine SAR evaluation.

INGREDIENT (% Weight)	750MHz Head	1750MHz Head	1950MHz Head	2450MHz Head	2600MHz Head	5GHz Head
Water	40.45	52.55	54.90	46.70	44.53	68.29
Salt	1.45	0.34	0.18	0	0.17	0
Sugar	57.60	0	0	0	0	0
HEC	0.40	0	0	0	0	0
Preventol	0.10	0	0	0	0	0
DGBE	0	47.50	44.92	53.30	55.30	2.44
Triton X-100	0	0	0	0	0	29.27

3.2 Tissue Calibration Result

The dielectric parameters of the liquids were verified prior to the SAR evaluation, using Dielectric Probe Kit and Vector Network Analyzer.

Head Tissue Simulate Measurement				
Frequency [MHz]	Description	Dielectric Parameters		Tissue Temp. [°C]
		ϵ_r	σ [s/m]	
750 MHz	Reference result ± 5% window	41.9 39.81 to 44	0.89 0.85 to 0.93	N/A
	22-Feb-22	42.33	0.88	22.1
782 MHz	Channel 23230	41.97	0.88	22.1
826.4 MHz	Channel 4132	41.48	0.89	22.1
829 MHz	Channel 20450	41.45	0.89	22.1
836.5 MHz	Channel 20525	41.37	0.89	22.1
836.6 MHz	Channel 4183	41.37	0.89	22.1
844 MHz	Channel 20600	41.29	0.9	22.1
846.6 MHz	Channel 4233	41.26	0.9	22.1

Head Tissue Simulate Measurement				
Frequency [MHz]	Description	Dielectric Parameters		Tissue Temp. [°C]
		ϵ_r	σ [s/m]	
750 MHz	Reference result ± 5% window	41.9 39.81 to 44	0.89 0.85 to 0.93	N/A
	07-Mar-22	42.28	0.89	21.9
704 MHz	Channel 23060	42.74	0.87	21.9
707.5 MHz	Channel 23095	42.71	0.87	21.9
711 MHz	Channel 23130	42.66	0.88	21.9

Head Tissue Simulate Measurement				
Frequency [MHz]	Description	Dielectric Parameters		Tissue Temp. [°C]
		ϵ_r	σ [s/m]	
750 MHz	Reference result ± 5% window	41.9 39.81 to 44	0.89 0.85 to 0.93	N/A
	08-Mar-22	41.97	0.88	22.1
673 MHz	Channel 133222	42.93	0.86	22.1
683 MHz	Channel 133322	42.81	0.87	22.1
688 MHz	Channel 133372	42.75	0.87	22.1
709 MHz	Channel 23780	42.49	0.87	22.1
710 MHz	Channel 23790	42.47	0.87	22.1
711 MHz	Channel 23800	42.46	0.87	22.1
793 MHz	Channel 23330	41.44	0.9	22.1
821.5 MHz	Channel 26765	41.08	0.9	22.1
831.5 MHz	Channel 26865	40.96	0.91	22.1
841.5 MHz	Channel 26965	40.83	0.91	22.1

Head Tissue Simulate Measurement				
Frequency [MHz]	Description	Dielectric Parameters		Tissue Temp. [°C]
		ϵ_r	σ [s/m]	
1750MHz	Reference result ± 5% window	40.1 38.1 to 42.11	1.37 1.30 to 1.44	N/A
	23-Feb-22	40.46	1.35	22.4
1720 MHz	Channel 20050	40.74	1.34	22.4
1720 MHz	Channel 132072	40.74	1.34	22.4
1732.5 MHz	Channel 20175	40.62	1.34	22.4
1745 MHz	Channel 20300	40.51	1.35	22.4
1745 MHz	Channel 132322	40.51	1.35	22.4
1770 MHz	Channel 132572	40.27	1.36	22.4

Head Tissue Simulate Measurement				
Frequency [MHz]	Description	Dielectric Parameters		Tissue Temp. [°C]
		ϵ_r	σ [s/m]	
1950MHz	Reference result ± 5% window	40 38 to 42	1.4 1.33 to 1.47	N/A
	23-Feb-22	39.48	1.41	22.4
1852.4 MHz	Channel 9262	40.45	1.37	22.4
1860 MHz	Channel 18700	40.38	1.37	22.4
1880 MHz	Channel 18900	40.18	1.38	22.4
1880 MHz	Channel 9400	40.18	1.38	22.4
1900 MHz	Channel 19100	39.98	1.39	22.4
1907.6 MHz	Channel 9538	39.91	1.39	22.4

Head Tissue Simulate Measurement				
Frequency [MHz]	Description	Dielectric Parameters		Tissue Temp. [°C]
		ϵ_r	σ [s/m]	
1950MHz	Reference result ± 5% window	40 38 to 42	1.4 1.33 to 1.47	N/A
	09-Mar-22	39.56	1.39	22.3
1860 MHz	Channel 26140	40.41	1.36	22.3
1882.5 MHz	Channel 26365	40.21	1.37	22.3
1905 MHz	Channel 26590	39.99	1.38	22.3

Head Tissue Simulate Measurement				
Frequency [MHz]	Description	Dielectric Parameters		Tissue Temp. [°C]
		ϵ_r	σ [s/m]	
2300MHz	Reference result ± 5% window	39.5 37.53 to 41.48	1.67 1.59 to 1.75	N/A
	09-Mar-22	39.45	1.66	22.3
2310 MHz	Channel 27710	39.33	1.66	22.3

Head Tissue Simulate Measurement				
Frequency [MHz]	Description	Dielectric Parameters		Tissue Temp. [°C]
		ϵ_r	σ [s/m]	
2450 MHz	Reference result ± 5% window	39.2 37.24 to 41.16	1.8 1.71 to 1.89	N/A
	16-Feb-22	39.67	1.85	21.7
2412 MHz	Channel 1	39.81	1.80	21.7
2437 MHz	Channel 6	39.72	1.83	21.7
2441 MHz	Channel 39	39.71	1.83	21.7
2457 MHz	Channel 10	39.64	1.85	21.7

Head Tissue Simulate Measurement				
Frequency [MHz]	Description	Dielectric Parameters		Tissue Temp. [°C]
		ϵ_r	σ [s/m]	
2450 MHz	Reference result ± 5% window	39.2 37.24 to 41.16	1.8 1.71 to 1.89	N/A
	11-Mar-22	38.52	1.81	21.9
2412 MHz	Channel 1	38.66	1.76	21.9
2437 MHz	Channel 6	38.57	1.79	21.9
2441 MHz	Channel 39	38.55	1.80	21.9
2457 MHz	Channel 10	38.49	1.82	21.9

Head Tissue Simulate Measurement				
Frequency [MHz]	Description	Dielectric Parameters		Tissue Temp. [°C]
		ϵ_r	σ [s/m]	
2600 MHz	Reference result ± 5% window	39 37.05 to 40.95	1.96 1.86 to 2.06	N/A
	09-Mar-22	38.99	1.94	22.3
2506 MHz	Channel 39750	40.11	1.89	22.3
2510 MHz	Channel 20850	40.06	1.89	22.3
2535 MHz	Channel 21100	39.76	1.91	22.3
2560 MHz	Channel 21350	39.46	1.92	22.3
2580 MHz	Channel 37850	39.22	1.93	22.3
2593 MHz	Channel 40620	39.08	1.94	22.3
2595 MHz	Channel 38000	39.05	1.94	22.3
2610 MHz	Channel 38150	38.87	1.94	22.3
2680 MHz	Channel 41490	38.04	1.99	22.3

Head Tissue Simulate Measurement				
Frequency [MHz]	Description	Dielectric Parameters		Tissue Temp. [°C]
		ϵ_r	σ [s/m]	
5250MHz	Reference result ± 5% window	35.95 34.15 to 37.75	4.71 4.47 to 4.95	N/A
	17-Feb-22	35.45	4.64	21.2
5270 MHz	Channel 54	35.41	4.67	21.2
5310 MHz	Channel 62	35.28	4.72	21.2

Head Tissue Simulate Measurement				
Frequency [MHz]	Description	Dielectric Parameters		Tissue Temp. [°C]
		ϵ_r	σ [s/m]	
5250MHz	Reference result ± 5% window	35.95 34.15 to 37.75	4.71 4.47 to 4.95	N/A
	11-Mar-22	36.53	4.78	21.9
5270 MHz	Channel 54	36.47	4.81	21.9
5310 MHz	Channel 62	36.36	4.86	21.9

Head Tissue Simulate Measurement				
Frequency [MHz]	Description	Dielectric Parameters		Tissue Temp. [°C]
		ϵ_r	σ [s/m]	
5600MHz	Reference result ± 5% window	35.5 33.73 to 37.28	5.07 4.82 to 5.32	N/A
	17-Feb-22	34.48	5.12	21.2
5530 MHz	Channel 106	34.67	4.99	21.2
5610 MHz	Channel 122	34.46	5.13	21.2
5690 MHz	Channel 138	34.24	5.23	21.2

Head Tissue Simulate Measurement				
Frequency [MHz]	Description	Dielectric Parameters		Tissue Temp. [°C]
		ϵ_r	σ [s/m]	
5600MHz	Reference result ± 5% window	35.5 33.73 to 37.28	5.07 4.82 to 5.32	N/A
	11-Mar-22	35.56	5.26	21.9
5530 MHz	Channel 106	35.75	5.16	21.9
5610 MHz	Channel 122	35.53	5.27	21.9
5690 MHz	Channel 138	35.32	5.29	21.9

Head Tissue Simulate Measurement				
Frequency [MHz]	Description	Dielectric Parameters		Tissue Temp. [°C]
		ϵ_r	σ [s/m]	
5800MHz	Reference result ± 5% window	35.3 33.54 to 37.07	5.27 5.01 to 5.53	N/A
	17-Feb-22	33.93	5.38	21.2
5775 MHz	Channel 155	34.01	5.35	21.2

Head Tissue Simulate Measurement				
Frequency [MHz]	Description	Dielectric Parameters		Tissue Temp. [°C]
		ϵ_r	σ [s/m]	
5800MHz	Reference result ± 5% window	35.3 33.54 to 37.07	5.27 5.01 to 5.53	N/A
	11-Mar-22	35.01	5.51	21.9
5775 MHz	Channel 155	35.08	5.48	21.9

3.3 Tissue Dielectric Parameters for Head and Body Phantoms

The head tissue dielectric parameters recommended by the IEC 62209-1 have been incorporated in the following table. These head parameters are derived from planar layer models simulating the highest expected SAR for the dielectric properties and tissue thickness variations in a human head. Other head tissue parameters that have not been specified are interpolated according to the head parameters specified in IEC 62209-1

Target Frequency (MHz)	Head	
	ϵ_r	σ (S/m)
300	45.3	0.87
450	43.5	0.87
750	41.9	0.89
835	41.5	0.90
900	41.5	0.97
1450	40.5	1.20
1640	40.2	1.31
1750	40.1	1.37
1800 – 2000	40.0	1.40
2450	39.2	1.80
3000	38.5	2.40
5000	36.2	4.45
5200	36.0	4.66
5400	35.8	4.86
5600	35.3	5.27
5800	35.3	5.27
6000	35.1	5.48

(ϵ_r = relative permittivity, σ = conductivity and $\rho = 1000 \text{ kg/m}^3$)

4. SAR Measurement Procedure

4.1 SAR System Check

4.1.1 Dipoles

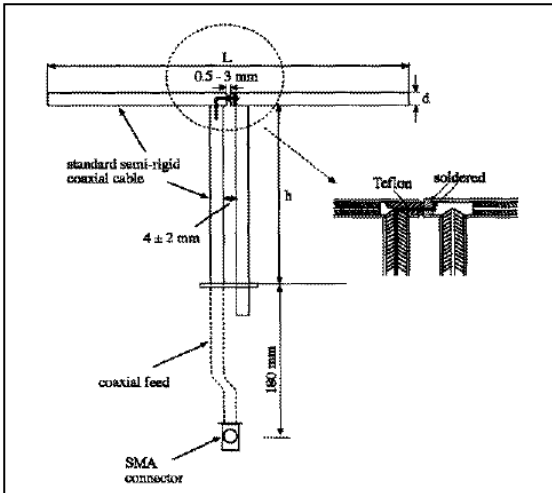

The dipoles used is based on the IEEE-1528 standard, and is complied with mechanical and electrical specifications in line with the requirements of both IEEE and FCC Supplement C. the table below provides details for the mechanical and electrical specifications for the dipoles.

Frequency	L (mm)	h (mm)	d (mm)
750MHz	176.0	100.0	6.35
1750MHz	75.2	42.9	3.6
1950MHz	66.3	38.5	3.6
2300MHz	55.5	32.6	3.6
2450MHz	51.5	30.4	3.6
2600MHz	48.5	28.8	3.6
5200M~5800MHz	20.6	40.3	3.6

4.1.2 System Check Result

System Performance Check at 750MHz, 1750MHz, 1950MHz				
Dipole Kit: D750V3				
Frequency [MHz]	Description	SAR [w/kg] 1g	SAR [w/kg] 10g	Tissue Temp. [°C]
750 MHz	Reference result ± 10% window	8.58 7.72 to 9.44	5.61 5.05 to 6.17	N/A
	22-Feb-22	8.28	5.36	22.1
	07-Mar-22	8.4	5.44	21.9
	08-Mar-22	8.44	5.68	22.1
Dipole Kit: D1750V2				
Frequency [MHz]	Description	SAR [w/kg] 1g	SAR [w/kg] 10g	Tissue Temp. [°C]
1750 MHz	Reference result ± 10% window	37.30 33.57 to 41.03	19.6 17.64 to 21.56	N/A
	23-Feb-22	39.16	20.6	22.4
Dipole Kit: D1950V3				
Frequency [MHz]	Description	SAR [w/kg] 1g	SAR [w/kg] 10g	Tissue Temp. [°C]
1950 MHz	Reference result ± 10% window	39.7 35.73 to 43.67	20.7 18.63 to 22.77	N/A
	23-Feb-22	41.6	20.96	22.4
	09-Mar-22	40.4	20.96	22.3
Note: (1) The power level is used 250mW (2) All SAR values are normalized to 1W forward power. (3) The reference result is from Appendix E.				

System Performance Check at 2300MHz, 2450MHz, 2600MHz
Dipole Kit: D2300V2

Frequency [MHz]	Description	SAR [w/kg] 1g	SAR [w/kg] 10g	Tissue Temp. [°C]
2300 MHz	Reference result ± 10% window	48.6 43.74 to 53.46	23.2 20.88 to 25.52	N/A
	09-Mar-22	48.4	23.52	22.3

Dipole Kit: D2450V2

Frequency [MHz]	Description	SAR [w/kg] 1g	SAR [w/kg] 10g	Tissue Temp. [°C]
2450 MHz	Reference result ± 10% window	53.1 47.79 to 58.41	24.6 22.14 to 27.06	N/A
	16-Feb-22	54.4	24.96	21.7
	11-Mar-22	55.6	25.52	21.9

Dipole Kit: ALS-D-2600-S-2

Frequency [MHz]	Description	SAR [w/kg] 1g	SAR [w/kg] 10g	Tissue Temp. [°C]
2600 MHz	Reference result ± 10% window	57.9 52.11 to 63.69	25.7 23.13 to 28.27	N/A
	09-Mar-22	58.4	25.96	22.3

Note: (1) The power level is used 250mW
 (2) All SAR values are normalized to 1W forward power.
 (3) The reference result is from Appendix E.

System Performance Check at 5250MHz, 5600MHz and 5800MHz
Dipole Kit: D5GHzV2

Frequency [MHz]	Description	SAR [w/kg] 1g	SAR [w/kg] 10g	Tissue Temp. [°C]
5250 MHz	Reference result ± 10% window	81.6 73.44 to 89.76	23.2 20.88 to 25.52	N/A
	17-Feb-22	84.8	23.6	21.2
	11-Mar-22	88.1	24.6	21.9
Frequency [MHz]	Description	SAR [w/kg] 1g	SAR [w/kg] 10g	Tissue Temp. [°C]
5600 MHz	Reference result ± 10% window	85.9 77.31 to 94.49	24.2 21.78 to 26.62	N/A
	17-Feb-22	84.2	24.8	21.2
	11-Mar-22	92.8	24.7	21.9
Frequency [MHz]	Description	SAR [w/kg] 1g	SAR [w/kg] 10g	Tissue Temp. [°C]
5800 MHz	Reference result ± 10% window	82.0 73.80 to 90.20	22.8 20.52 to 25.08	N/A
	17-Feb-22	85.3	24.7	21.2
	11-Mar-22	87.2	23.6	21.9

Note: (1) The power level is used 100mW
 (2) All SAR values are normalized to 1W forward power.
 (3) The reference result is from Appendix E.

4.2 SAR Measurement Procedure

The Dasy5 calculates SAR using the following equation,

$$SAR = \frac{\sigma |E|^2}{\rho}$$

σ : represents the simulated tissue conductivity

ρ : represents the tissue density

The EUT is set to transmit at the required power in line with product specification, at each frequency relating to the LOW, MID, and HIGH channel settings.

Pre-scans are made on the device to establish the location for the transmitting antenna, using a large area scan in either air or tissue simulation fluid.

The EUT is placed against the Universal Phantom where the maximum area scan dimensions are larger than the physical size of the resonating antenna. When the scan size is not large enough to cover the peak SAR distribution, it is modified by either extending the area scan size in both the X and Y directions, or the device is shifted within the predefined area.

The area scan is then run to establish the peak SAR location (interpolated resolution set at 1mm²) which is then used to orient the center of the zoom scan. The zoom scan is then executed and the 1g and 10g averages are derived from the zoom scan volume (interpolated resolution set at 1mm³).

5. SAR Exposure Limits

SAR assessments have been made in line with the requirements of IEEE-1528, FCC Supplement C, and comply with ANSI/IEEE C95.1-1992 “Uncontrolled Environments” limits. These limits apply to a location which is deemed as “Uncontrolled Environment” which can be described as a situation where the general public may be exposed to an RF source with no prior knowledge or control over their exposure.

Limits for General Population/Uncontrolled Exposure (W/kg)

Type Exposure	Uncontrolled Environment Limit
Spatial Peak SAR (1g cube tissue for brain or body)	1.60 W/kg
Spatial Average SAR (whole body)	0.08 W/kg
Spatial Peak SAR (10g for hands, feet, ankles and wrist)	4.00 W/kg

6. Test Equipment List

Instrument	Manufacturer	Model No.	Serial No.	Last Calibration	Next Calibration
Reference Dipole 750MHz	Speag	D750V3	1031	2020/05/27	2023/5/26
Reference Dipole 1750MHz	Speag	D1750V2	1113	2019/11/21	2022/11/20
Reference Dipole 1950MHz	Speag	D1950V3	1213	2019/11/05	2022/11/4
Reference Dipole 2300MHz	Speag	D2300V2	1045	2019/05/14	2022/5/13
Reference Dipole 2450MHz	Speag	D2450V2	930	2019/11/21	2022/11/20
Reference Dipole 2600MHz	Aprel	ALS-D-2600-S-2	QTK-225	2019/5/14	2022/5/13
Reference Dipole 5GHz	Speag	D5GHzV2	1041	2020/05/25	2023/5/24
Device Holder	Speag	N/A	N/A	N/A	N/A
Data Acquisition Electronic	Speag	DAE4	1207	2021/11/22	2022/11/21
E-Field Probe	Speag	EX3DV4	3698	2021/11/24	2022/11/23
Power Amplifier	Mini-Circuit	ZHL-42	D051404-20	N/A	N/A
Power Amplifier	Mini-Circuit	ZVE-8G	541100241	N/A	N/A
Directional Coupler	Agilent	87300C	MY44300353	N/A	N/A1
Attenuator	Woken	WATT-218FS-10	N/A	N/A	N/A1
Attenuator	Mini-Circuit	BW-S20W2+	N/A	N/A	N/A1
Universal Radio Communication	Anritsu	MT8820C	6201465467	2021/8/13	2022/8/12
Universal Radio Communication	R&S	CMW500	157304	2021/11/29	2022/11/28
Vector Network Analyzer	Keysight	E5071C	MY46106342	2021/10/18	2022/10/17
Signal Generator	Anritsu	MG3694A	041902	2021/8/26	2022/8/25
Power Meter	Anritsu	ML2487A	6K00001447	2021/11/2	2022/11/1
Power Sensor	Anritsu	MA2411B	1339194	2021/11/2	2022/11/1

Note: 1. System Check, the path loss measured by the network analyzer, includes the signal generator, amplifier, cable, attenuator and directional coupler.

7. Measurement Uncertainty

DASY5 Uncertainty (According to IEEE 1528-2013)								
Measurement uncertainty for 30 MHz to 3 GHz								
Error Description	Uncert. value	Prob. Dist.	Div.	(ci) 1g	(ci) 10g	Std. Unc. (1g)	Std. Unc. (10g)	(vi) V _{eff}
Measurement System								
Probe Calibration	±6%	N	1	1	1	±6.0%	±6.0%	∞
Axial Isotropy	±4.7%	R	√3	0.7	0.7	±1.9%	±1.9%	∞
Hemispherical Isotropy	±9.6%	R	√3	0.7	0.7	±3.9%	±3.9%	∞
Boundary Effects	±1.0%	R	√3	1	1	±0.6%	±0.6%	∞
Linearity	±4.7%	R	√3	1	1	±2.7%	±2.7%	∞
System Detection Limits	±1.0%	R	√3	1	1	±0.6%	±0.6%	∞
Modulation Response	±2.4%	R	√3	1	1	±1.4%	±1.4%	∞
Readout Electronics	±0.3%	N	1	1	1	±0.3%	±0.3%	∞
Response Time	±0.8%	R	√3	1	1	±0.5%	±0.5%	∞
Integration Time	±2.6%	R	√3	1	1	±1.5%	±1.5%	∞
RF Ambient Noise	±3.0%	R	√3	1	1	±1.7%	±1.7%	∞
RF Ambient Reflections	±3.0%	R	√3	1	1	±1.7%	±1.7%	∞
Probe Positioner	±0.4%	R	√3	1	1	±0.2%	±0.2%	∞
Probe Positioning	±2.9%	R	√3	1	1	±1.7%	±1.7%	∞
Max. SAR Eval.	±4.0%	R	√3	1	1	±1.2%	±1.2%	∞
Test Sample Related								
Device Positioning	±2.9%	N	1	1	1	±2.9%	±2.9%	145
Device Holder	±3.6%	N	1	1	1	±3.6%	±3.6%	5
Power Drift	±5.0%	R	√3	1	1	±2.9%	±2.9%	∞
Power Scaling	±0%	R	√3	1	1	±0.0%	±0.0%	
Phantom and Setup								
Phantom Uncertainty	±6.1%	R	√3	1	1	±3.5%	±3.5%	∞
SAR correction	±1.9%	R	√3	1	0.84	±1.1%	±0.9%	∞
Liquid Conductivity (meas.)	±2.5%	R	√3	0.78	0.71	±1.1%	±1.0%	∞
Liquid Permittivity (meas.)	±2.5%	R	√3	0.26	0.26	±0.3%	±0.4%	∞
Temp. unc. - Conductivity	±3.4%	R	√3	0.78	0.71	±1.5%	±1.4%	∞
Temp. unc. - Permittivity	±0.4%	R	√3	0.23	0.26	±0.1%	±0.1%	∞
Combined Std. Uncertainty						±11.2%	±11.1%	361
Expanded STD Uncertainty						±22.3%	±22.2%	

DASY5 Uncertainty (According to IEEE 1528-2013) Measurement uncertainty for 3GHz to 6 GHz								
Error Description	Uncert. value	Prob. Dist.	Div.	(ci) 1g	(ci) 10g	Std. Unc. (1g)	Std. Unc. (10g)	(vi) V _{eff}
Measurement System								
Probe Calibration	±6.55%	N	1	1	1	±6.55%	±6.55%	∞
Axial Isotropy	±4.7%	R	$\sqrt{3}$	0.7	0.7	±1.9%	±1.9%	∞
Hemispherical Isotropy	±9.6%	R	$\sqrt{3}$	0.7	0.7	±3.9%	±3.9%	∞
Boundary Effects	±2.0%	R	$\sqrt{3}$	1	1	±1.2%	±1.2%	∞
Linearity	±4.7%	R	$\sqrt{3}$	1	1	±2.7%	±2.7%	∞
System Detection Limits	±1.0%	R	$\sqrt{3}$	1	1	±0.6%	±0.6%	∞
Modulation Response	±2.4%	R	$\sqrt{3}$	1	1	±1.4%	±1.4%	∞
Readout Electronics	±0.3%	N	1	1	1	±0.3%	±0.3%	∞
Response Time	±0.8%	R	$\sqrt{3}$	1	1	±0.5%	±0.5%	∞
Integration Time	±2.6%	R	$\sqrt{3}$	1	1	±1.5%	±1.5%	∞
RF Ambient Noise	±3.0%	R	$\sqrt{3}$	1	1	±1.7%	±1.7%	∞
RF Ambient Reflections	±3.0%	R	$\sqrt{3}$	1	1	±1.7%	±1.7%	∞
Probe Positioner	±0.8%	R	$\sqrt{3}$	1	1	±0.5%	±0.5%	∞
Probe Positioning	±6.7%	R	$\sqrt{3}$	1	1	±3.9%	±3.9%	∞
Post-processing	±4.0%	R	$\sqrt{3}$	1	1	±2.3%	±2.3%	∞
Test Sample Related								
Device Positioning	±2.9%	N	1	1	1	±2.9%	±2.9%	145
Device Holder	±3.6%	N	1	1	1	±3.6%	±3.6%	5
Power Drift	±5.0%	R	$\sqrt{3}$	1	1	±2.9%	±2.9%	∞
Power Scaling	±0%	R	$\sqrt{3}$	1	1	±0.0%	±0.0%	
Phantom and Setup								
Phantom Uncertainty	±6.6%	R	$\sqrt{3}$	1	1	±3.8%	±3.8%	∞
SAR correction	±1.9%	R	$\sqrt{3}$	1	1	±1.1%	±0.9%	∞
Liquid Conductivity (meas.)	±2.5%	R	$\sqrt{3}$	1	0.84	±1.1%	±1.0%	∞
Liquid Permittivity (meas.)	±2.5%	R	$\sqrt{3}$	0.26	0.26	±0.3%	±0.4%	∞
Temp. unc. - Conductivity	±3.4%	R	$\sqrt{3}$	0.78	0.71	±1.5%	±1.4%	∞
Temp. unc. - Permittivity	±0.4%	R	$\sqrt{3}$	0.23	0.26	±0.1%	±0.1%	∞
Combined Std. Uncertainty						±12.3%	±12.2%	748
Expanded STD Uncertainty						±24.6%	±24.5%	

8. Conducted Power Measurement (Including tolerance allowed for production unit)

Maximum Output Power (Including tolerance) (dBm)			
Exposure Conditions		Bottom	
Distance (mm)		15	0
Power State		P-Sensor Off	P-Sensor On
WCDMA B2	RMC	25.7	17.5
	HSDPA	25.7	17.5
	HSUPA	25.7	17.5
WCDMA B5	RMC	25.2	21.5
	HSDPA	25.2	21.5
	HSUPA	25.2	21.5
LTE Band 2	QPSK	25.7	17.5
LTE Band 4	QPSK	25.7	17
LTE Band 5	QPSK	25.2	21
LTE Band 7	QPSK	25.2	18
LTE Band 12	QPSK	25.2	21
LTE Band 13	QPSK	25.2	21
LTE Band 14	QPSK	25.2	21
LTE Band 17	QPSK	25.2	21
LTE Band 25	QPSK	25.7	17.5
LTE Band 26	QPSK	25.2	21
LTE Band 30	QPSK	24	16.5
LTE Band 38	QPSK	25.2	20
LTE Band 41	QPSK	25.2	20
LTE Band 66	QPSK	25.2	17
LTE Band 71	QPSK	25.2	21
LTE Band 41(PC2)	QPSK	27.2	22

WLAN 2.4G 2TX SISO									
	Frequency	Mode	BW	SISO-Main(TX1)			SISO-Aux(TX2)		
				CH	AV Power	AV Target	CH	AV Power	AV Target
				DSSS/OFDM mode specified maximum output power at an antenna port	WLAN 2.4GHz	b	20	1	17.54
				6	17.69	19.5	6	17.88	19.5
				10	17.56	19.5	10	17.52	19.5
				11	16.91	18.5	11	16.69	18.5
				12	16.86	18.5	12	16.87	18.5
				13	14.98	16.5	13	14.90	16.5
		g	20	1	15.48	17	1	15.49	17
				6	17.65	19.5	6	17.51	19.5
				11	15.24	17	11	15.07	17
				12	12.45	14	12	12.33	14
				13	2.53	4.5	13	2.89	4.5
		n (HT)	20	1	15.41	17	1	15.44	17
				6	17.64	19.5	6	17.84	19.5
				11	15.12	17	11	15.46	17
				12	12.44	14	12	12.33	14
				13	2.54	4.5	13	2.61	4.5
			40	3	13.11	15	3	13.29	15
				6	16.94	18.5	6	16.64	18.5
				9	13.22	15	9	13.46	15
				10	6.75	8.5	10	6.43	8.5
				11	0.47	2	11	0.43	2

WLAN 5G 2TX SISO																		
OFDM mode specified maximum output power at an antenna port	Frequency	Mode	BW	SISO-Main(TX1)			SISO-Aux(TX2)			Frequency	Mode	BW	SISO-Main(TX1)			SISO-Aux(TX2)		
				CH	AV Power	AV Target	CH	AV Power	AV Target				CH	AV Power	AV Target	CH	AV Power	AV Target
OFDM mode specified maximum output power at an antenna port	U-NII-1 (5150~5250MHz)	a	20	36	10.59	12.5	36	10.51	12.5	U-NII-2C (5470~5725MHz)	a	20	100	16.98	18.5	100	16.74	18.5
				40	10.54	12.5	40	10.55	12.5				112	16.64	18.5	112	16.71	18.5
				44	10.66	12.5	44	10.74	12.5				116	16.61	18.5	116	16.94	18.5
				48	10.52	12.5	48	10.84	12.5				128	16.87	18.5	128	16.77	18.5
		132	16.93	18.5	132	16.71	18.5											
		100	17.83	19.5	100	17.64	19.5											
		n (HT)	20	36	11.45	13	36	11.43	13		112	17.69	19.5	112	17.52	19.5		
				40	11.44	13	40	11.47	13		116	17.61	19.5	116	17.79	19.5		
				44	11.35	13	44	11.34	13		128	17.62	19.5	128	17.71	19.5		
				48	11.31	13	48	11.38	13		132	17.73	19.5	132	17.74	19.5		
		40	38	13.09	15	38	13.36	15	102		15.23	17	102	15.15	17			
			46	13.34	15	46	13.34	15	110		17.81	19.5	110	17.61	19.5			
	ac(VHT)	80	42	13.37	14	42	12.26	14	118	17.91	19.5	118	17.64	19.5				
	U-NII-2A (5250~5350MHz)	a	20	52	17.58	19.5	52	17.84	19.5	126	17.81	19.5	126	17.79	19.5			
				56	17.52	19.5	56	17.82	19.5	134	17.24	19	134	17.34	19			
				60	17.73	19.5	60	17.83	19.5	20	144	17.24	19	144	17.49	19		
				64	17.23	19	64	17.48	19	40	142	17.94	19.5	142	17.91	19.5		
		n (HT)	20	52	17.52	19.5	52	17.75	19.5	106	12.87	14.5	106	12.61	14.5			
				56	17.81	19.5	56	17.79	19.5	122	17.71	19.5	122	17.89	19.5			
				60	17.71	19.5	60	17.84	19.5	138	17.64	19.5	138	17.65	19.5			
64				17.14	19	64	17.44	19										
40		54	17.96	19.5	54	17.86	19.5											
		62	10.81	12.5	62	10.61	12.5											
ac(VHT)		80	58	11.14	13	58	11.17	13										
U-NII-3 (5725~5850MHz)		a	20	149	17.94	19.5	149	17.78	19.5	n (HT)	20	149	17.86	19.5	149	17.69	19.5	
	157			17.84	19.5	157	17.73	19.5	157			17.74	19.5	157	17.74	19.5		
	165			17.64	19.5	165	17.79	19.5	165			17.68	19.5	165	17.82	19.5		
	40	151	17.71	19.5	151	17.81	19.5	40	151	17.71	19.5	151	17.81	19.5				
		159	17.82	19.5	159	17.72	19.5		159	17.82	19.5	159	17.72	19.5				
	ac(VHT)	80	155	17.91	19.5	155	17.73	19.5										

BT Only Support Aux									
Bluetooth mode maximum output power	Frequency	Mode	Modulation	SISO-Main(TX1)			SISO-Aux(TX2)		
				CH	AV Power	AV Target	CH	AV Power	AV Target
BT 2.4GHz	BR	GFSK	0	N/A	N/A	0	10.12	12.0	
			39	N/A	N/A	39	10.30	12.0	
			78	N/A	N/A	78	10.25	12.0	
	EDR	8DPSK	0	N/A	N/A	0	7.14	12.0	
			39	N/A	N/A	39	8.04	12.0	
			78	N/A	N/A	78	7.49	12.0	
	BLE	GFSK	0	N/A	N/A	0	0.59	5.0	
			19	N/A	N/A	19	1.71	5.0	
			39	N/A	N/A	39	1.08	5.0	

P-Sensor Off

Band	WCDMA B2			WCDMA B5		
CHANNEL	9262	9400	9538	4132	4183	4233
RMC	24.25	24.6	24.51	24.37	24.46	24.34
HSDPA Set 1	23.14	22.85	23.3	23.34	23.27	23.51
HSDPA Set 2	22.63	22.4	22.84	22.85	22.82	22.93
HSDPA Set 3	22.7	22.53	22.92	22.79	22.71	22.90
HSDPA Set 4	22.78	22.52	22.9	22.83	22.75	22.86
HSUPA Set 1	23.01	22.8	23.06	23.22	23.11	23.29
HSUPA Set 2	22.59	22.36	22.81	22.76	22.71	22.89
HSUPA Set 3	22.65	22.42	22.65	22.75	22.8	22.81
HSUPA Set 4	22.65	22.39	22.74	22.77	22.66	22.76
HSUPA Set 5	22.71	22.35	22.81	22.78	22.58	22.69

Note: Unit : dBm

P-Sensor On

Band	WCDMA B2			WCDMA B5		
CHANNEL	9262	9400	9538	4132	4183	4233
RMC	15.92	16.01	15.71	19.81	19.92	19.84
HSDPA Set 1	15.8	15.95	15.69	19.86	19.87	19.81
HSDPA Set 2	15.83	15.94	15.66	19.85	19.82	19.83
HSDPA Set 3	15.77	15.93	15.62	19.79	19.81	19.80
HSDPA Set 4	15.78	15.9	15.7	19.83	19.85	19.79
HSUPA Set 1	15.62	15.86	15.67	19.72	19.85	19.65
HSUPA Set 2	15.77	15.9	15.69	19.69	19.88	19.77
HSUPA Set 3	15.89	15.91	15.57	19.79	19.9	19.79
HSUPA Set 4	15.79	15.79	15.59	19.78	19.79	19.62
HSUPA Set 5	15.64	15.84	15.61	18.78	19.89	19.71

Note: Unit : dBm

P-Sensor Off

Channel	Modulation	LTE Band 2							
		RB	RB	Maximum Conducted Output Power					
		No.	Offset	1.4M	3M	5M	10M	15M	20M
Low	QPSK	1	#0	24.37	24.37	24.37	24.31	24.33	24.38
		1	#Mid	24.30	24.26	24.35	24.28	24.26	24.20
		1	#Max	24.32	24.32	24.32	24.21	24.19	24.03
		50%	#0	23.29	23.40	23.42	23.44	23.41	23.48
		50%	#Mid	23.10	23.46	23.41	23.43	23.41	23.44
		50%	#Max	23.32	23.40	23.40	23.40	23.32	23.25
		100%	--	23.34	23.46	23.44	23.41	23.42	23.31
	16QAM	1	#0	23.35	23.83	23.32	23.65	23.51	23.27
		1	#Mid	23.44	23.87	23.25	23.65	23.39	23.20
		1	#Max	23.35	23.74	23.23	23.54	23.33	23.24
		50%	#0	23.16	22.59	22.50	22.49	22.48	22.56
		50%	#Mid	23.12	22.58	22.56	22.47	22.49	22.54
		50%	#Max	23.15	22.54	22.47	22.38	22.41	22.31
		100%	--	22.48	22.53	22.45	22.45	22.44	22.34
	64QAM	1	#0	22.52	22.58	22.55	22.63	22.67	22.7
		1	#Mid	22.55	22.68	22.54	22.56	22.65	22.54
		1	#Max	22.53	22.59	22.56	22.55	22.51	22.34
		50%	#0	22.49	21.55	21.57	21.58	21.63	21.64
		50%	#Mid	22.55	21.55	21.57	21.57	21.6	21.6
		50%	#Max	22.52	21.57	21.56	21.5	21.57	21.37
		100%	--	21.48	21.57	21.54	21.56	21.52	21.38
Mid	QPSK	1	#0	24.12	24.14	24.16	24.24	24.18	24.47
		1	#Mid	24.23	24.28	24.15	24.18	24.13	24.04
		1	#Max	24.14	24.18	24.15	24.20	24.16	24.05
		50%	#0	23.22	23.21	23.18	23.23	23.25	23.55
		50%	#Mid	23.30	23.23	23.22	23.24	23.23	23.20
		50%	#Max	23.26	23.23	23.17	23.16	23.18	23.16
		100%	--	23.27	23.24	23.18	23.20	23.18	23.19
	16QAM	1	#0	23.33	23.32	23.27	23.53	23.30	23.34
		1	#Mid	23.35	23.39	23.23	23.47	23.24	23.34
		1	#Max	23.32	23.27	23.28	23.47	23.28	23.37

		50%	#0	23.18	22.35	22.26	22.26	22.25	22.35	
		50%	#Mid	23.18	22.38	22.26	22.24	22.32	22.36	
		50%	#Max	23.13	22.35	22.22	22.22	22.20	22.27	
		100%	--	22.34	22.42	22.28	22.25	22.27	22.28	
	64QAM	1	#0	22.2	22.4	22.43	22.4	22.43	22.41	
		1	#Mid	22.29	22.52	22.42	22.45	22.38	22.28	
		1	#Max	22.17	22.36	22.37	22.42	22.41	22.29	
		50%	#0	22.21	21.31	21.37	21.32	21.38	21.32	
		50%	#Mid	22.28	21.39	21.37	21.36	21.39	21.29	
		50%	#Max	22.21	21.32	21.35	21.34	21.35	21.2	
		100%	--	21.14	21.35	21.31	21.24	21.26	21.25	
	High	QPSK	1	#0	24.25	24.33	24.24	24.17	24.13	24.36
			1	#Mid	24.34	24.30	24.29	24.27	24.10	24.18
1			#Max	24.25	24.30	24.19	24.26	24.22	24.22	
50%			#0	23.13	23.13	23.25	23.23	23.22	23.14	
50%			#Mid	23.17	23.16	23.31	23.20	23.25	23.24	
50%			#Max	23.13	23.12	23.27	23.28	23.19	23.21	
100%			--	23.10	23.18	23.26	23.22	23.21	23.21	
16QAM		1	#0	23.42	23.43	23.39	23.64	23.50	23.46	
		1	#Mid	23.43	23.52	23.41	23.63	23.52	23.42	
		1	#Max	23.36	23.39	23.39	23.66	23.56	23.47	
		50%	#0	23.01	22.45	22.37	22.20	22.27	22.16	
		50%	#Mid	23.01	22.49	22.37	22.25	22.27	22.32	
		50%	#Max	23.09	22.46	22.30	22.32	22.25	22.24	
		100%	--	22.49	22.45	22.27	22.30	22.28	22.26	
64QAM		1	#0	22.31	22.43	22.44	22.46	22.28	22.37	
		1	#Mid	22.36	22.44	22.4	22.47	22.34	22.29	
		1	#Max	22.29	22.39	22.33	22.46	22.37	22.43	
		50%	#0	22.32	21.38	21.36	21.26	21.28	21.16	
		50%	#Mid	22.34	21.42	21.4	21.27	21.29	21.29	
		50%	#Max	22.29	21.38	21.33	21.33	21.27	21.24	
		100%	--	21.27	21.36	21.34	21.28	21.27	21.25	

P-Sensor On

Channel	Modulation	LTE Band 2							
		RB	RB	Maximum Conducted Output Power					
		No.	Offset	1.4M	3M	5M	10M	15M	20M
Low	QPSK	1	#0	15.78	15.85	15.89	15.99	15.99	15.97
		1	#Mid	15.88	15.97	15.84	15.93	15.90	15.82
		1	#Max	15.81	15.83	15.82	15.87	15.97	15.86
		50%	#0	15.83	15.89	15.83	15.85	15.90	15.94
		50%	#Mid	15.86	15.83	15.82	15.81	15.89	15.85
		50%	#Max	15.81	15.87	15.87	15.84	15.87	15.85
		100%	--	15.81	15.88	15.86	15.81	15.88	15.90
	16QAM	1	#0	15.55	15.53	15.56	15.50	15.50	15.50
		1	#Mid	15.57	15.63	15.55	15.51	15.53	15.50
		1	#Max	15.54	15.54	15.55	15.50	15.54	15.51
		50%	#0	15.58	15.57	15.54	15.53	15.51	15.52
		50%	#Mid	15.51	15.53	15.54	15.53	15.58	15.50
		50%	#Max	15.56	15.54	15.50	15.50	15.51	15.50
		100%	--	15.59	15.53	15.52	15.51	15.54	15.58
	64QAM	1	#0	16.16	16.01	15.91	16.21	16.36	16.35
		1	#Mid	16.17	16.11	15.89	16.1	16.31	16.3
		1	#Max	16.15	15.96	15.84	16.16	16.16	16.07
		50%	#0	16.05	16.01	16.03	16.01	16.08	16.05
		50%	#Mid	16.13	16.07	16.1	16.03	16.04	16.05
		50%	#Max	16.07	15.99	16.03	15.99	15.97	15.87
		100%	--	15.92	15.91	16	15.98	15.99	15.85
Mid	QPSK	1	#0	15.78	16.08	16.11	15.99	16.15	16.18
		1	#Mid	15.88	16.09	16.09	15.93	16.10	16.00
		1	#Max	15.81	16.08	16.04	15.87	16.00	15.82
		50%	#0	15.83	15.88	15.90	15.90	15.91	15.90
		50%	#Mid	15.86	15.90	15.87	15.79	15.90	15.89
		50%	#Max	15.81	15.86	15.69	15.74	15.87	15.85
		100%	--	15.81	15.77	15.88	15.81	15.88	15.89
	16QAM	1	#0	15.51	15.54	15.58	15.59	15.86	15.56
		1	#Mid	15.52	15.55	15.57	15.55	15.57	15.56
		1	#Max	15.51	15.57	15.50	15.50	15.59	15.53

		50%	#0	15.00	15.54	15.59	15.52	15.51	15.59	
		50%	#Mid	15.50	15.55	15.55	15.55	15.53	15.59	
		50%	#Max	15.58	15.53	15.52	15.51	15.52	15.51	
		100%	--	15.51	15.51	15.50	15.54	15.56	15.51	
	64QAM	1	#0	15.89	16	15.91	16.15	16.14	16.15	
		1	#Mid	15.96	16.16	15.89	16.13	15.98	16.09	
		1	#Max	15.98	16.01	15.87	16.1	16.16	16.1	
		50%	#0	15.86	15.85	15.85	15.8	15.85	15.85	
		50%	#Mid	15.92	15.89	15.85	15.79	15.87	15.83	
		50%	#Max	15.83	15.83	15.81	15.79	15.79	15.76	
	100%	--	15.71	15.69	15.81	15.8	15.84	15.79		
	High	QPSK	1	#0	15.91	15.97	15.95	15.92	15.81	15.95
			1	#Mid	15.94	16.05	15.97	16.02	15.91	15.91
1			#Max	15.84	15.93	15.91	16.04	16.01	15.94	
50%			#0	15.93	15.91	15.91	15.88	15.90	15.78	
50%			#Mid	15.93	15.89	15.90	15.86	15.86	15.82	
50%			#Max	15.92	15.85	15.88	15.89	15.89	15.83	
100%			--	15.89	15.83	15.85	15.80	15.85	15.90	
16QAM		1	#0	15.55	15.53	15.58	15.52	15.56	15.52	
		1	#Mid	15.56	15.55	15.51	15.55	15.53	15.53	
		1	#Max	15.54	15.58	15.52	15.56	15.54	15.54	
		50%	#0	15.56	15.55	15.52	15.51	15.55	15.54	
		50%	#Mid	15.57	15.54	15.55	15.54	15.55	15.59	
		50%	#Max	15.55	15.55	15.59	15.51	15.51	15.57	
		100%	--	15.58	15.52	15.50	15.58	15.53	15.55	
64QAM		1	#0	16.08	16.06	15.93	16.21	16	15.79	
		1	#Mid	16.16	16.16	15.98	16.29	16.1	15.78	
		1	#Max	16.06	16.05	15.89	16.23	16.19	15.76	
		50%	#0	15.98	15.92	15.9	15.78	15.89	15.76	
		50%	#Mid	16.03	15.95	15.94	15.82	15.9	15.82	
		50%	#Max	15.95	15.91	15.89	15.88	15.83	15.83	
		100%	--	15.76	15.79	15.91	15.75	15.77	15.79	

P-Sensor Off

Channel	Modulation	LTE Band 4							
		RB	RB	Maximum Conducted Output Power					
		No.	Offset	1.4M	3M	5M	10M	15M	20M
Low	QPSK	1	#0	24.31	24.28	24.26	24.32	24.37	24.40
		1	#Mid	24.29	24.38	24.26	24.29	24.31	24.24
		1	#Max	24.28	24.24	24.21	24.23	24.33	24.20
		50%	#0	23.32	23.34	23.42	23.32	23.38	23.41
		50%	#Mid	23.33	23.39	23.42	23.31	23.37	23.40
		50%	#Max	23.31	23.34	23.32	23.37	23.39	23.40
		100%	--	23.31	23.39	23.38	23.33	23.41	23.42
	16QAM	1	#0	23.38	23.57	23.55	23.58	23.53	23.76
		1	#Mid	23.51	23.79	23.61	23.60	23.58	23.80
		1	#Max	23.40	23.60	23.56	23.60	23.53	23.74
		50%	#0	22.10	22.43	22.36	22.45	22.45	22.43
		50%	#Mid	22.12	22.49	22.44	22.48	22.49	22.54
		50%	#Max	22.26	22.46	22.39	22.41	22.56	22.43
		100%	--	22.39	22.42	22.38	22.48	22.50	22.49
	64QAM	1	#0	22.54	22.54	22.54	22.61	22.61	22.62
		1	#Mid	22.57	22.7	22.63	22.62	22.52	22.66
		1	#Max	22.49	22.54	22.58	22.58	22.56	22.57
		50%	#0	22.56	21.55	21.58	21.53	21.53	21.49
		50%	#Mid	22.59	21.55	21.57	21.54	21.58	21.62
		50%	#Max	22.52	21.51	21.52	21.49	21.61	21.51
		100%	--	21.45	21.49	21.52	21.51	21.58	21.55
Mid	QPSK	1	#0	24.20	24.31	24.29	24.40	24.41	24.45
		1	#Mid	24.32	24.42	24.31	24.42	24.33	24.31
		1	#Max	24.22	24.24	24.21	24.37	24.17	24.17
		50%	#0	23.30	23.37	23.37	23.44	23.40	23.44
		50%	#Mid	23.36	23.34	23.40	23.43	23.41	23.45
		50%	#Max	23.29	23.33	23.34	23.38	23.35	23.35
		100%	--	23.35	23.37	23.40	23.37	23.38	23.40
	16QAM	1	#0	23.24	23.69	23.58	23.77	23.44	23.93
		1	#Mid	23.32	23.77	23.60	23.60	23.29	23.71
		1	#Max	23.24	23.57	23.48	23.54	23.20	23.56

		50%	#0	22.34	22.45	22.40	22.46	22.50	22.54	
		50%	#Mid	22.90	22.45	22.42	22.47	22.51	22.49	
		50%	#Max	22.91	22.41	22.39	22.40	22.44	22.40	
		100%	--	22.36	22.46	22.40	22.44	22.45	22.44	
	64QAM	1	#0	22.57	22.6	22.62	22.69	22.72	22.69	
		1	#Mid	22.59	22.68	22.59	22.61	22.58	22.66	
		1	#Max	22.53	22.49	22.53	22.48	22.45	22.4	
		50%	#0	22.54	21.51	21.58	21.58	21.61	21.54	
		50%	#Mid	22.58	21.58	21.59	21.54	21.59	21.57	
		50%	#Max	22.52	21.54	21.52	21.47	21.52	21.46	
		100%	--	21.46	21.53	21.5	21.5	21.52	21.52	
	High	QPSK	1	#0	24.15	24.24	24.34	24.40	24.30	24.36
			1	#Mid	24.20	24.34	24.32	24.33	24.28	24.27
1			#Max	24.15	24.20	24.25	24.28	24.12	24.18	
50%			#0	23.33	23.22	23.28	23.36	23.34	23.40	
50%			#Mid	23.28	23.28	23.31	23.36	23.32	23.41	
50%			#Max	23.22	23.25	23.23	23.29	23.24	23.33	
100%			--	23.25	23.23	23.32	23.30	23.33	23.34	
16QAM		1	#0	23.33	23.71	23.59	23.69	23.47	23.69	
		1	#Mid	23.42	23.67	23.63	23.64	23.48	23.72	
		1	#Max	23.31	23.71	23.60	23.61	23.34	23.55	
		50%	#0	22.15	22.33	22.35	22.41	22.42	22.40	
		50%	#Mid	22.20	22.36	22.37	22.36	22.47	22.38	
		50%	#Max	22.14	22.34	22.29	22.28	22.43	22.30	
		100%	--	22.32	22.40	22.33	22.43	22.37	22.30	
64QAM		1	#0	22.51	22.58	22.59	22.58	22.66	22.61	
		1	#Mid	22.57	22.64	22.58	22.58	22.66	22.63	
		1	#Max	22.48	22.53	22.52	22.47	22.47	22.41	
		50%	#0	22.49	21.46	21.48	21.49	21.51	21.5	
		50%	#Mid	22.54	21.51	21.53	21.45	21.53	21.5	
		50%	#Max	22.47	21.47	21.44	21.4	21.47	21.4	
		100%	--	21.36	21.41	21.42	21.46	21.48	21.44	

P-Sensor On

Channel	Modulation	LTE Band 4							
		RB	RB	Maximum Conducted Output Power					
		No.	Offset	1.4M	3M	5M	10M	15M	20M
Low	QPSK	1	#0	15.65	15.59	15.67	15.66	15.66	15.91
		1	#Mid	15.64	15.68	15.71	15.59	15.62	15.76
		1	#Max	15.59	15.49	15.57	15.47	15.61	15.71
		50%	#0	15.59	15.57	15.70	15.60	15.71	15.82
		50%	#Mid	15.65	15.61	15.72	15.62	15.70	15.80
		50%	#Max	15.61	15.60	15.67	15.59	15.74	15.84
		100%	--	15.61	15.62	15.68	15.62	15.80	15.89
	16QAM	1	#0	15.56	15.60	15.62	15.59	15.40	15.79
		1	#Mid	15.58	15.66	15.63	15.66	15.61	15.67
		1	#Max	15.55	15.67	15.54	15.58	15.65	15.65
		50%	#0	15.30	15.48	15.38	15.51	15.66	15.64
		50%	#Mid	15.39	15.54	15.40	15.49	15.68	15.70
		50%	#Max	15.30	15.48	15.39	15.42	15.62	15.76
		100%	--	15.41	15.50	15.35	15.50	15.66	15.66
	64QAM	1	#0	15.45	15.59	15.67	15.54	15.72	15.67
		1	#Mid	15.5	15.56	15.62	15.44	15.71	15.67
		1	#Max	15.38	15.36	15.62	15.46	15.63	15.61
		50%	#0	15.51	15.56	15.57	15.52	15.48	15.48
		50%	#Mid	15.51	15.61	15.61	15.48	15.55	15.58
		50%	#Max	15.52	15.54	15.61	15.43	15.59	15.51
		100%	--	15.37	15.53	15.5	15.46	15.56	15.52
Mid	QPSK	1	#0	15.64	15.58	15.61	15.61	15.72	15.98
		1	#Mid	15.67	15.79	15.63	15.60	15.61	15.83
		1	#Max	15.63	15.54	15.54	15.53	15.57	15.70
		50%	#0	15.67	15.61	15.62	15.65	15.75	15.90
		50%	#Mid	15.71	15.67	15.68	15.66	15.74	15.85
		50%	#Max	15.66	15.61	15.60	15.60	15.70	15.78
		100%	--	15.67	15.64	15.61	15.61	15.71	15.84
	16QAM	1	#0	15.57	15.62	15.67	15.51	15.48	15.69
		1	#Mid	15.64	15.78	15.60	15.56	15.60	15.85
		1	#Max	15.55	15.54	15.63	15.60	15.59	15.80

		50%	#0	15.33	15.42	15.50	15.54	15.50	15.79	
		50%	#Mid	15.40	15.46	15.54	15.55	15.51	15.84	
		50%	#Max	15.34	15.38	15.51	15.49	15.47	15.85	
		100%	--	15.42	15.41	15.49	15.55	15.49	15.81	
	64QAM	1	#0	15.42	15.31	15.67	15.57	15.68	15.81	
		1	#Mid	15.48	15.42	15.68	15.43	15.59	15.73	
		1	#Max	15.43	15.32	15.64	15.42	15.51	15.56	
		50%	#0	15.46	15.56	15.55	15.49	15.51	15.54	
		50%	#Mid	15.54	15.62	15.55	15.46	15.53	15.5	
		50%	#Max	15.46	15.53	15.52	15.36	15.48	15.45	
		100%	--	15.52	15.52	15.43	15.47	15.49	15.47	
	High	QPSK	1	#0	15.50	15.54	15.59	15.68	15.66	15.79
			1	#Mid	15.58	15.65	15.68	15.61	15.61	15.73
1			#Max	15.48	15.49	15.51	15.63	15.44	15.58	
50%			#0	15.59	15.61	15.67	15.64	15.64	15.91	
50%			#Mid	15.58	15.65	15.66	15.54	15.63	15.72	
50%			#Max	15.54	15.58	15.55	15.50	15.55	15.74	
100%			--	15.53	15.57	15.63	15.50	15.64	15.67	
16QAM		1	#0	15.43	15.52	15.60	15.60	15.60	15.69	
		1	#Mid	15.52	15.66	15.60	15.66	15.63	15.60	
		1	#Max	15.36	15.41	15.55	15.53	15.62	15.55	
		50%	#0	15.21	15.34	15.40	15.45	15.56	15.70	
		50%	#Mid	15.27	15.37	15.41	15.47	15.59	15.70	
		50%	#Max	15.20	15.32	15.39	15.35	15.48	15.63	
		100%	--	15.30	15.31	15.39	15.44	15.55	15.66	
64QAM		1	#0	15.5	15.25	15.64	15.7	15.62	15.46	
		1	#Mid	15.53	15.39	15.6	15.63	15.53	15.47	
		1	#Max	15.49	15.31	15.56	15.53	15.41	15.3	
		50%	#0	15.35	15.36	15.48	15.44	15.47	15.47	
		50%	#Mid	15.42	15.35	15.52	15.38	15.45	15.47	
		50%	#Max	15.33	15.3	15.5	15.36	15.39	15.33	
		100%	--	15.43	15.46	15.31	15.38	15.38	15.4	

P-Sensor Off

Channel	Modulation	LTE Band 5							
		RB	RB	Maximum Conducted Output Power					
		No.	Offset	1.4M	3M	5M	10M	15M	20M
Low	QPSK	1	#0	23.75	23.83	23.95	23.99	--	--
		1	#Mid	23.86	23.95	23.88	24.01	--	--
		1	#Max	23.72	23.87	23.85	23.85	--	--
		50%	#0	22.84	22.92	22.88	22.89	--	--
		50%	#Mid	22.88	22.91	22.92	23.06	--	--
		50%	#Max	22.84	22.92	22.82	22.96	--	--
		100%	--	22.81	22.93	22.87	23.00	--	--
	16QAM	1	#0	23.03	23.17	23.29	23.09	--	--
		1	#Mid	23.07	23.28	23.35	23.14	--	--
		1	#Max	22.93	23.28	23.26	23.09	--	--
		50%	#0	22.68	22.91	21.98	21.99	--	--
		50%	#Mid	22.70	22.95	21.98	22.09	--	--
		50%	#Max	22.69	22.95	21.96	22.01	--	--
		100%	--	21.98	22.17	21.92	22.07	--	--
	64QAM	1	#0	22.05	22.07	22.08	22.12	--	--
		1	#Mid	22.13	22.15	22.04	22.07	--	--
		1	#Max	22.05	22.04	22.02	22.13	--	--
		50%	#0	22.02	21	20.99	20.95	--	--
		50%	#Mid	22.08	21.02	21.05	21.1	--	--
		50%	#Max	21.99	20.98	21.03	21.05	--	--
		100%	--	20.92	20.97	20.97	21.05	--	--
Mid	QPSK	1	#0	23.81	23.91	23.83	24.10	--	--
		1	#Mid	23.86	24.02	23.83	24.22	--	--
		1	#Max	23.86	23.96	23.90	23.93	--	--
		50%	#0	22.80	23.01	22.87	23.05	--	--
		50%	#Mid	22.86	22.99	22.89	22.94	--	--
		50%	#Max	22.81	22.98	22.82	22.98	--	--
		100%	--	22.80	22.95	22.85	22.91	--	--
	16QAM	1	#0	23.00	23.16	23.25	23.17	--	--
		1	#Mid	23.07	23.26	23.19	23.16	--	--
		1	#Max	23.04	23.30	23.16	23.29	--	--

		50%	#0	22.59	22.85	21.98	21.98	--	--	
		50%	#Mid	22.64	22.94	22.02	21.96	--	--	
		50%	#Max	22.76	22.97	21.94	22.00	--	--	
		100%	--	22.00	22.04	21.99	21.94	--	--	
	64QAM	1	#0	21.96	22.09	22.06	22.08	--	--	
		1	#Mid	22.03	22.12	22.01	22.01	--	--	
		1	#Max	21.97	22.03	22.01	22.19	--	--	
		50%	#0	21.98	20.95	20.99	20.96	--	--	
		50%	#Mid	22.02	20.97	21.01	20.98	--	--	
		50%	#Max	21.94	20.94	20.93	21.01	--	--	
	100%	--	20.9	20.96	20.96	20.95	--	--		
	High	QPSK	1	#0	24.01	24.03	24.06	23.95	--	--
			1	#Mid	24.06	24.11	24.15	24.20	--	--
1			#Max	23.93	24.10	24.08	24.14	--	--	
50%			#0	22.98	23.01	22.95	22.99	--	--	
50%			#Mid	22.96	23.02	22.98	22.98	--	--	
50%			#Max	22.84	23.01	22.89	22.94	--	--	
100%			--	22.90	23.04	23.01	22.91	--	--	
16QAM		1	#0	23.19	23.44	23.20	23.27	--	--	
		1	#Mid	23.15	23.59	23.21	23.40	--	--	
		1	#Max	23.09	23.57	23.12	23.31	--	--	
		50%	#0	22.54	23.00	22.18	22.04	--	--	
		50%	#Mid	22.50	23.02	22.19	22.03	--	--	
		50%	#Max	22.64	22.98	22.21	22.09	--	--	
		100%	--	22.22	22.15	22.15	22.04	--	--	
64QAM		1	#0	22.23	22.17	22.25	22.09	--	--	
		1	#Mid	22.18	22.33	22.32	22.27	--	--	
		1	#Max	22.08	22.15	22.14	22.21	--	--	
		50%	#0	22.16	21.13	21.19	21.07	--	--	
		50%	#Mid	22.19	21.24	21.18	21.06	--	--	
		50%	#Max	22.13	21.23	21.24	21.11	--	--	
		100%	--	21.11	21.12	21.11	21.08	--	--	

P-Sensor On

Channel	Modulation	LTE Band 5							
		RB	RB	Maximum Conducted Output Power					
		No.	Offset	1.4M	3M	5M	10M	15M	20M
Low	QPSK	1	#0	19.48	19.45	19.50	19.70	--	--
		1	#Mid	19.55	19.51	19.49	19.54	--	--
		1	#Max	19.47	19.40	19.48	19.53	--	--
		50%	#0	19.55	19.52	19.54	19.54	--	--
		50%	#Mid	19.55	19.54	19.54	19.64	--	--
		50%	#Max	19.49	19.52	19.49	19.61	--	--
		100%	--	19.54	19.50	19.50	19.64	--	--
	16QAM	1	#0	19.42	19.49	19.53	19.35	--	--
		1	#Mid	19.49	19.57	19.51	19.46	--	--
		1	#Max	19.37	19.43	19.45	19.50	--	--
		50%	#0	19.16	19.31	19.34	19.24	--	--
		50%	#Mid	19.22	19.31	19.31	19.35	--	--
		50%	#Max	19.22	19.24	19.26	19.27	--	--
		100%	--	19.28	19.27	19.29	19.32	--	--
	64QAM	1	#0	19.3	19.3	19.06	19.39	--	--
		1	#Mid	19.36	19.43	19.07	19.4	--	--
		1	#Max	19.24	19.27	19.06	19.41	--	--
		50%	#0	19.25	19.17	19.13	19.13	--	--
		50%	#Mid	19.34	19.25	19.19	19.21	--	--
		50%	#Max	19.3	19.15	19.19	19.15	--	--
		100%	--	19.11	19.09	19.18	19.17	--	--
Mid	QPSK	1	#0	19.54	19.63	19.67	19.85	--	--
		1	#Mid	19.62	19.65	19.59	19.60	--	--
		1	#Max	19.63	19.65	19.71	19.59	--	--
		50%	#0	19.59	19.64	19.71	19.49	--	--
		50%	#Mid	19.63	19.66	19.70	19.70	--	--
		50%	#Max	19.55	19.62	19.64	19.52	--	--
		100%	--	19.43	19.64	19.57	19.58	--	--
	16QAM	1	#0	19.58	19.55	19.63	16.68	--	--
		1	#Mid	19.65	19.66	19.57	19.70	--	--
		1	#Max	19.58	19.64	19.62	19.68	--	--

		50%	#0	19.34	19.33	19.39	19.54	--	--	
		50%	#Mid	19.39	19.35	19.37	19.55	--	--	
		50%	#Max	19.29	19.31	19.31	19.57	--	--	
		100%	--	19.39	19.35	19.34	19.55	--	--	
	64QAM	1	#0	19.27	19.28	19.11	19.3	--	--	
		1	#Mid	19.32	19.35	19.06	19.13	--	--	
		1	#Max	19.3	19.34	19.16	19.31	--	--	
		50%	#0	19.17	19.1	19.13	19.16	--	--	
		50%	#Mid	19.22	19.12	19.15	19.13	--	--	
		50%	#Max	19.21	19.08	19.08	19.14	--	--	
		100%	--	19.02	19.1	19.13	19.07	--	--	
	High	QPSK	1	#0	19.66	19.57	19.63	19.80	--	--
			1	#Mid	19.62	19.65	19.66	19.72	--	--
1			#Max	19.53	19.66	19.66	19.72	--	--	
50%			#0	19.60	19.60	19.60	19.71	--	--	
50%			#Mid	19.63	19.61	19.60	19.77	--	--	
50%			#Max	19.62	19.61	19.62	19.60	--	--	
100%			--	19.61	19.62	19.60	19.63	--	--	
16QAM		1	#0	19.65	19.64	19.57	19.53	--	--	
		1	#Mid	19.70	19.66	19.66	19.65	--	--	
		1	#Max	19.59	19.69	19.69	19.20	--	--	
		50%	#0	19.51	19.47	19.43	19.34	--	--	
		50%	#Mid	19.50	19.65	19.44	19.34	--	--	
		50%	#Max	19.42	19.64	19.51	19.38	--	--	
		100%	--	19.56	19.45	19.38	19.32	--	--	
64QAM		1	#0	19.48	19.54	19.39	19.25	--	--	
		1	#Mid	19.58	19.59	19.42	19.41	--	--	
		1	#Max	19.47	19.53	19.34	19.38	--	--	
		50%	#0	19.44	19.26	19.36	19.24	--	--	
		50%	#Mid	19.46	19.38	19.35	19.21	--	--	
		50%	#Max	19.42	19.33	19.37	19.3	--	--	
		100%	--	19.28	19.3	19.3	19.18	--	--	

P-Sensor Off

Channel	Modulation	LTE Band 7							
		RB	RB	Maximum Conducted Output Power					
		No.	Offset	1.4M	3M	5M	10M	15M	20M
Low	QPSK	1	#0	--	--	24.05	24.29	24.23	24.41
		1	#Mid	--	--	24.07	24.19	24.28	24.48
		1	#Max	--	--	24.04	24.34	24.29	24.51
		50%	#0	--	--	23.08	23.37	23.32	23.51
		50%	#Mid	--	--	23.12	23.42	23.38	23.50
		50%	#Max	--	--	23.11	23.40	23.35	23.56
		100%	--	--	--	23.10	23.40	23.37	23.57
	16QAM	1	#0	--	--	23.22	23.48	23.45	23.58
		1	#Mid	--	--	23.27	23.49	23.56	23.70
		1	#Max	--	--	23.26	23.61	23.58	23.85
		50%	#0	--	--	22.15	22.41	22.38	22.59
		50%	#Mid	--	--	22.19	22.44	22.45	22.63
		50%	#Max	--	--	22.12	22.45	22.42	22.70
		100%	--	--	--	22.19	22.46	22.43	22.67
	64QAM	1	#0	--	--	22.96	23.09	22.63	21.91
		1	#Mid	--	--	22.89	22.57	23.19	22.05
		1	#Max	--	--	22.97	22.55	22.73	22.22
		50%	#0	--	--	21.95	21.86	21.74	21.01
		50%	#Mid	--	--	21.92	21.91	21.82	21.01
		50%	#Max	--	--	21.93	21.88	21.75	21.17
		100%	--	--	--	22	21.91	21.77	21.13
Mid	QPSK	1	#0	--	--	24.04	24.31	24.28	24.42
		1	#Mid	--	--	24.04	24.33	24.32	24.42
		1	#Max	--	--	24.04	24.35	24.31	24.61
		50%	#0	--	--	23.09	23.39	23.34	23.56
		50%	#Mid	--	--	23.12	23.40	23.38	23.56
		50%	#Max	--	--	23.08	23.37	23.33	23.57
		100%	--	--	--	23.07	23.37	23.33	23.60
	16QAM	1	#0	--	--	23.26	23.57	23.56	23.62
		1	#Mid	--	--	23.22	23.56	23.57	23.61
		1	#Max	--	--	23.27	23.59	23.58	23.64

		50%	#0	--	--	22.09	22.44	22.42	22.50	
		50%	#Mid	--	--	22.10	22.42	22.43	22.55	
		50%	#Max	--	--	22.05	22.43	22.46	22.54	
		100%	--	--	--	22.08	22.44	22.39	22.51	
	64QAM	1	#0	--	--	23	23.01	22.92	22.03	
		1	#Mid	--	--	23.02	23.03	22.91	22.27	
		1	#Max	--	--	22.96	23	22.92	21.98	
		50%	#0	--	--	21.99	21.95	21.83	21.1	
		50%	#Mid	--	--	21.88	21.95	21.89	21.09	
		50%	#Max	--	--	21.93	22	21.92	21.1	
	100%	--	--	--	22.01	21.92	21.86	21.06		
	High	QPSK	1	#0	--	--	23.76	24.16	24.14	24.27
			1	#Mid	--	--	23.75	24.17	24.14	24.23
1			#Max	--	--	23.80	24.17	24.20	24.40	
50%			#0	--	--	22.87	23.23	23.22	23.34	
50%			#Mid	--	--	22.87	23.25	23.25	23.36	
50%			#Max	--	--	22.88	23.23	23.22	23.37	
100%			--	--	--	22.87	23.21	23.23	23.40	
16QAM		1	#0	--	--	23.07	23.51	23.45	23.47	
		1	#Mid	--	--	23.02	23.43	23.44	23.46	
		1	#Max	--	--	22.98	23.43	23.31	23.37	
		50%	#0	--	--	21.91	22.29	22.30	22.41	
		50%	#Mid	--	--	21.93	22.30	22.31	22.44	
		50%	#Max	--	--	21.88	22.30	22.29	22.43	
		100%	--	--	--	21.91	22.33	22.32	22.39	
64QAM		1	#0	--	--	22.9	23.03	22.99	22.14	
		1	#Mid	--	--	22.79	23.04	22.71	22.07	
		1	#Max	--	--	22.81	23.02	22.67	21.82	
		50%	#0	--	--	21.75	21.82	21.69	20.86	
		50%	#Mid	--	--	21.95	21.7	21.79	20.86	
		50%	#Max	--	--	21.84	21.79	21.76	20.9	
		100%	--	--	--	21.82	21.74	21.77	20.84	

P-Sensor On

Channel	Modulation	LTE Band 7							
		RB	RB	Maximum Conducted Output Power					
		No.	Offset	1.4M	3M	5M	10M	15M	20M
Low	QPSK	1	#0	--	--	16.54	16.79	16.82	17.01
		1	#Mid	--	--	16.53	16.83	16.86	16.97
		1	#Max	--	--	16.56	16.75	16.97	16.95
		50%	#0	--	--	16.65	16.76	16.93	17.03
		50%	#Mid	--	--	16.67	16.73	16.89	17.02
		50%	#Max	--	--	16.61	16.72	16.98	17.00
		100%	--	--	--	16.58	16.79	16.97	16.99
	16QAM	1	#0	--	--	16.78	17.10	16.75	16.90
		1	#Mid	--	--	16.71	17.10	16.89	16.97
		1	#Max	--	--	16.69	17.09	16.99	16.96
		50%	#0	--	--	16.61	16.78	16.65	16.85
		50%	#Mid	--	--	16.60	16.81	16.61	16.86
		50%	#Max	--	--	16.54	16.76	16.74	16.83
		100%	--	--	--	16.49	16.82	16.71	16.80
	64QAM	1	#0	--	--	16.11	16.37	16.38	16.02
		1	#Mid	--	--	16.13	16.06	16.38	16.38
		1	#Max	--	--	16.14	16.15	16.39	16.56
		50%	#0	--	--	16.13	16.04	16.08	16.26
		50%	#Mid	--	--	16.11	16.03	16.24	16.62
		50%	#Max	--	--	16.09	16.03	16.16	16.4
		100%	--	--	--	16.3	16.26	16.39	16.68
Mid	QPSK	1	#0	--	--	16.58	16.75	16.87	17.22
		1	#Mid	--	--	16.55	16.79	16.84	17.20
		1	#Max	--	--	16.52	16.68	16.85	17.13
		50%	#0	--	--	16.52	16.68	16.92	17.12
		50%	#Mid	--	--	16.54	16.72	17.00	16.96
		50%	#Max	--	--	16.54	16.71	16.95	16.96
		100%	--	--	--	16.59	16.64	16.91	17.06
	16QAM	1	#0	--	--	16.90	16.91	16.99	17.00
		1	#Mid	--	--	16.92	16.92	16.94	16.97
		1	#Max	--	--	16.95	16.92	16.97	16.94

		50%	#0	--	--	16.49	16.74	16.97	16.65	
		50%	#Mid	--	--	16.52	16.80	17.00	16.66	
		50%	#Max	--	--	16.51	16.77	16.94	16.64	
		100%	--	--	--	16.45	16.70	16.98	16.65	
	64QAM	1	#0	--	--	16.05	16.12	16.25	16.22	
		1	#Mid	--	--	16.06	16.08	16.09	16.27	
		1	#Max	--	--	16.07	16.12	16	16.38	
		50%	#0	--	--	16.02	16.01	16.31	16.39	
		50%	#Mid	--	--	16.02	16.04	16.13	16.62	
		50%	#Max	--	--	16	16	16.16	16.37	
	100%	--	--	--	16.23	16.21	16.36	16.62		
	High	QPSK	1	#0	--	--	16.54	16.59	16.86	17.01
			1	#Mid	--	--	16.59	16.60	16.83	16.99
1			#Max	--	--	16.57	16.62	16.86	16.90	
50%			#0	--	--	16.53	16.65	16.90	16.99	
50%			#Mid	--	--	16.51	16.68	16.96	16.95	
50%			#Max	--	--	16.52	16.63	16.89	16.96	
100%			--	--	--	16.54	16.61	16.89	17.00	
16QAM		1	#0	--	--	16.90	16.66	16.98	16.92	
		1	#Mid	--	--	16.93	16.57	16.94	16.98	
		1	#Max	--	--	16.90	16.61	16.97	16.92	
		50%	#0	--	--	16.41	16.67	16.91	16.59	
		50%	#Mid	--	--	16.42	16.71	16.97	16.58	
		50%	#Max	--	--	16.43	16.64	16.98	16.58	
		100%	--	--	--	16.42	16.68	16.96	16.51	
64QAM		1	#0	--	--	16.03	16.27	16.1	16.69	
		1	#Mid	--	--	16.2	16.19	16.12	17.18	
		1	#Max	--	--	16.17	16.27	15.82	16.79	
		50%	#0	--	--	16.01	16.06	16.17	16.41	
		50%	#Mid	--	--	16.05	16.07	16.15	16.61	
		50%	#Max	--	--	16.02	16.07	16.14	16.35	
		100%	--	--	--	16.21	16.16	16.37	16.59	

P-Sensor Off

Channel	Modulation	LTE Band 12							
		RB	RB	Maximum Conducted Output Power					
		No.	Offset	1.4M	3M	5M	10M	15M	20M
Low	QPSK	1	#0	23.31	23.35	23.39	23.54	--	--
		1	#Mid	23.42	23.59	23.45	23.73	--	--
		1	#Max	23.30	23.46	23.57	23.85	--	--
		50%	#0	22.40	22.60	22.58	22.77	--	--
		50%	#Mid	22.42	22.60	22.60	22.87	--	--
		50%	#Max	22.40	22.57	22.64	22.93	--	--
		100%	--	22.40	22.59	22.58	22.85	--	--
	16QAM	1	#0	22.68	22.62	22.67	22.91	--	--
		1	#Mid	22.77	22.90	22.81	23.02	--	--
		1	#Max	22.70	22.80	22.90	23.12	--	--
		50%	#0	21.44	21.75	21.67	21.87	--	--
		50%	#Mid	21.41	21.74	21.68	21.92	--	--
		50%	#Max	21.41	21.73	21.73	22.00	--	--
		100%	--	21.57	21.74	21.66	21.91	--	--
	64QAM	1	#0	21.65	21.69	21.64	21.63	--	--
		1	#Mid	21.71	21.86	21.72	21.78	--	--
		1	#Max	21.62	21.73	21.86	21.85	--	--
		50%	#0	21.6	20.75	20.73	20.66	--	--
		50%	#Mid	21.63	20.75	20.76	20.76	--	--
		50%	#Max	21.61	20.71	20.81	20.82	--	--
		100%	--	20.5	20.75	20.67	20.7	--	--
Mid	QPSK	1	#0	23.56	23.48	23.49	23.63	--	--
		1	#Mid	23.61	23.69	23.60	23.80	--	--
		1	#Max	23.50	23.54	23.58	23.94	--	--
		50%	#0	22.69	22.64	22.64	22.91	--	--
		50%	#Mid	22.67	22.68	22.69	22.92	--	--
		50%	#Max	22.77	22.68	22.66	22.93	--	--
		100%	--	22.62	22.70	22.70	22.89	--	--
	16QAM	1	#0	22.76	22.67	22.76	22.88	--	--
		1	#Mid	22.84	22.91	22.80	23.03	--	--
		1	#Max	22.81	22.81	22.86	23.18	--	--

		50%	#0	21.58	21.73	21.73	21.94	--	--	
		50%	#Mid	21.63	21.79	21.74	21.96	--	--	
		50%	#Max	21.55	21.72	21.71	21.93	--	--	
		100%	--	21.72	21.78	21.70	21.94	--	--	
	64QAM	1	#0	21.75	21.7	21.74	21.67	--	--	
		1	#Mid	21.85	21.93	21.83	21.81	--	--	
		1	#Max	21.74	21.81	21.83	22.06	--	--	
		50%	#0	21.76	20.76	20.77	20.8	--	--	
		50%	#Mid	21.76	20.8	20.81	20.77	--	--	
		50%	#Max	21.75	20.75	20.79	20.77	--	--	
	100%	--	20.68	20.72	20.73	20.75	--	--		
	High	QPSK	1	#0	23.62	23.57	23.61	23.73	--	--
			1	#Mid	23.66	23.76	23.59	23.82	--	--
1			#Max	23.59	23.68	23.67	23.91	--	--	
50%			#0	22.62	22.61	22.65	22.80	--	--	
50%			#Mid	22.67	22.75	22.68	22.82	--	--	
50%			#Max	22.66	22.76	22.67	22.88	--	--	
100%			--	22.71	22.67	22.66	22.82	--	--	
16QAM		1	#0	22.86	22.90	22.88	22.98	--	--	
		1	#Mid	22.90	23.03	22.93	23.12	--	--	
		1	#Max	22.75	22.90	22.94	23.16	--	--	
		50%	#0	21.68	21.75	21.76	21.89	--	--	
		50%	#Mid	21.69	21.87	21.77	21.92	--	--	
		50%	#Max	21.67	21.82	21.74	21.97	--	--	
		100%	--	21.84	21.74	21.71	21.90	--	--	
64QAM		1	#0	21.78	21.85	21.83	21.84	--	--	
		1	#Mid	21.87	22.04	21.91	21.95	--	--	
		1	#Max	21.86	21.9	21.93	22.01	--	--	
		50%	#0	21.85	20.8	20.85	20.71	--	--	
		50%	#Mid	21.86	20.92	20.87	20.75	--	--	
		50%	#Max	21.85	20.93	20.83	20.78	--	--	
		100%	--	20.8	20.76	20.77	20.74	--	--	

P-Sensor On

Channel	Modulation	LTE Band 12							
		RB	RB	Maximum Conducted Output Power					
		No.	Offset	1.4M	3M	5M	10M	15M	20M
Low	QPSK	1	#0	19.01	19.07	19.08	19.17	--	--
		1	#Mid	19.00	19.09	19.06	19.29	--	--
		1	#Max	19.03	19.08	19.03	19.41	--	--
		50%	#0	18.69	19.05	19.02	19.02	--	--
		50%	#Mid	19.01	19.06	19.01	19.00	--	--
		50%	#Max	19.03	19.05	19.08	19.00	--	--
		100%	--	19.00	19.00	19.00	19.00	--	--
	16QAM	1	#0	19.05	19.00	19.06	19.00	--	--
		1	#Mid	19.01	19.03	19.06	19.01	--	--
		1	#Max	19.03	19.05	19.01	19.02	--	--
		50%	#0	19.07	19.03	19.06	19.01	--	--
		50%	#Mid	19.00	19.07	19.05	19.05	--	--
		50%	#Max	19.01	19.07	19.01	19.02	--	--
		100%	--	19.06	19.01	19.03	19.01	--	--
	64QAM	1	#0	19.02	19.06	19.07	19.01	--	--
		1	#Mid	19.07	19.07	19.11	19.07	--	--
		1	#Max	19.04	19.06	19.23	19.06	--	--
		50%	#0	19.09	19.06	19.05	19.02	--	--
		50%	#Mid	19.02	19.04	19.03	19.09	--	--
		50%	#Max	19.06	19.03	19.15	19.05	--	--
		100%	--	19.04	19.09	19.06	19	--	--
Mid	QPSK	1	#0	19.21	19.18	19.06	19.38	--	--
		1	#Mid	19.18	19.42	19.01	19.49	--	--
		1	#Max	19.01	19.32	19.11	19.51	--	--
		50%	#0	19.04	19.08	19.07	19.12	--	--
		50%	#Mid	19.07	19.09	19.00	19.03	--	--
		50%	#Max	19.02	19.06	19.07	19.08	--	--
		100%	--	19.09	19.07	19.08	19.13	--	--
	16QAM	1	#0	19.08	19.07	19.04	19.05	--	--
		1	#Mid	19.03	19.03	19.03	19.05	--	--
		1	#Max	19.04	19.07	19.03	19.01	--	--

		50%	#0	19.01	19.06	19.07	19.01	--	--	
		50%	#Mid	9.05	19.09	19.06	19.02	--	--	
		50%	#Max	19.01	19.06	19.06	19.04	--	--	
		100%	--	19.03	19.02	19.07	19.02	--	--	
	64QAM	1	#0	19.03	19.04	19.03	19.03	--	--	
		1	#Mid	19.05	19.13	19.02	19.26	--	--	
		1	#Max	19	19.09	19.08	19.4	--	--	
		50%	#0	19.1	19.07	19.06	19.05	--	--	
		50%	#Mid	19.18	19.04	19.08	19.09	--	--	
		50%	#Max	19.11	19	19.07	19.08	--	--	
	100%	--	19.09	19.02	19.02	19.03	--	--		
	High	QPSK	1	#0	19.05	19.02	19.01	19.02	--	--
			1	#Mid	19.04	19.01	19.01	19.07	--	--
1			#Max	19.09	19.00	19.02	19.10	--	--	
50%			#0	19.08	19.09	19.06	19.10	--	--	
50%			#Mid	19.07	19.01	19.04	19.00	--	--	
50%			#Max	19.04	19.05	19.01	19.02	--	--	
100%			--	19.02	19.05	19.00	19.07	--	--	
16QAM		1	#0	19.02	19.03	19.06	19.06	--	--	
		1	#Mid	19.05	19.04	19.07	19.06	--	--	
		1	#Max	19.04	19.01	19.04	19.05	--	--	
		50%	#0	19.00	19.02	19.05	19.05	--	--	
		50%	#Mid	19.02	19.05	19.00	19.07	--	--	
		50%	#Max	19.03	19.03	19.06	19.05	--	--	
		100%	--	19.04	19.04	16.05	19.07	--	--	
64QAM		1	#0	19.23	19.33	19.23	19.07	--	--	
		1	#Mid	19.3	19.43	19.27	19.03	--	--	
		1	#Max	19.22	19.39	19.33	19.1	--	--	
		50%	#0	19.11	19.06	19.1	19.01	--	--	
		50%	#Mid	19.15	19.2	19.13	19.02	--	--	
		50%	#Max	19.14	19.15	19.1	19.1	--	--	
		100%	--	19.04	19.01	19.01	19.02	--	--	

P-Sensor Off

Channel	Modulation	LTE Band 13							
		RB	RB	Maximum Conducted Output Power					
		No.	Offset	1.4M	3M	5M	10M	15M	20M
Low	QPSK	1	#0	--	--	24.24	--	--	--
		1	#Mid	--	--	24.22	--	--	--
		1	#Max	--	--	24.22	--	--	--
		50%	#0	--	--	23.28	--	--	--
		50%	#Mid	--	--	23.30	--	--	--
		50%	#Max	--	--	23.25	--	--	--
		100%	--	--	--	23.27	--	--	--
	16QAM	1	#0	--	--	23.33	--	--	--
		1	#Mid	--	--	23.33	--	--	--
		1	#Max	--	--	23.27	--	--	--
		50%	#0	--	--	22.29	--	--	--
		50%	#Mid	--	--	22.36	--	--	--
		50%	#Max	--	--	22.33	--	--	--
		100%	--	--	--	22.42	--	--	--
	64QAM	1	#0	--	--	22.35	--	--	--
		1	#Mid	--	--	22.43	--	--	--
		1	#Max	--	--	22.41	--	--	--
		50%	#0	--	--	21.38	--	--	--
		50%	#Mid	--	--	21.38	--	--	--
		50%	#Max	--	--	21.35	--	--	--
		100%	--	--	--	21.35	--	--	--
Mid	QPSK	1	#0	--	--	24.19	24.25	--	--
		1	#Mid	--	--	24.21	24.21	--	--
		1	#Max	--	--	24.10	24.11	--	--
		50%	#0	--	--	23.25	23.27	--	--
		50%	#Mid	--	--	23.26	23.29	--	--
		50%	#Max	--	--	23.24	23.23	--	--
		100%	--	--	--	23.25	23.22	--	--
	16QAM	1	#0	--	--	23.23	23.27	--	--
		1	#Mid	--	--	23.22	23.34	--	--
		1	#Max	--	--	23.26	23.17	--	--

		50%	#0	--	--	22.33	22.38	--	--	
		50%	#Mid	--	--	22.36	22.39	--	--	
		50%	#Max	--	--	22.30	22.33	--	--	
		100%	--	--	--	22.33	22.29	--	--	
	64QAM	1	#0	--	--	22.35	22.37	--	--	
		1	#Mid	--	--	22.35	22.39	--	--	
		1	#Max	--	--	22.23	22.18	--	--	
		50%	#0	--	--	21.31	21.29	--	--	
		50%	#Mid	--	--	21.37	21.31	--	--	
		50%	#Max	--	--	21.34	21.3	--	--	
		100%	--	--	--	21.28	21.27	--	--	
	High	QPSK	1	#0	--	--	24.11	--	--	--
			1	#Mid	--	--	23.96	--	--	--
1			#Max	--	--	23.96	--	--	--	
50%			#0	--	--	23.25	--	--	--	
50%			#Mid	--	--	23.24	--	--	--	
50%			#Max	--	--	23.11	--	--	--	
100%			--	--	--	23.22	--	--	--	
16QAM		1	#0	--	--	23.24	--	--	--	
		1	#Mid	--	--	23.22	--	--	--	
		1	#Max	--	--	23.16	--	--	--	
		50%	#0	--	--	22.33	--	--	--	
		50%	#Mid	--	--	22.32	--	--	--	
		50%	#Max	--	--	22.15	--	--	--	
		100%	--	--	--	22.29	--	--	--	
64QAM		1	#0	--	--	22.39	--	--	--	
		1	#Mid	--	--	22.29	--	--	--	
		1	#Max	--	--	22.15	--	--	--	
		50%	#0	--	--	21.29	--	--	--	
		50%	#Mid	--	--	21.32	--	--	--	
		50%	#Max	--	--	21.16	--	--	--	
		100%	--	--	--	21.25	--	--	--	

P-Sensor On

Channel	Modulation	LTE Band 13							
		RB	RB	Maximum Conducted Output Power					
		No.	Offset	1.4M	3M	5M	10M	15M	20M
Low	QPSK	1	#0	--	--	19.51	--	--	--
		1	#Mid	--	--	19.51	--	--	--
		1	#Max	--	--	19.44	--	--	--
		50%	#0	--	--	19.54	--	--	--
		50%	#Mid	--	--	19.57	--	--	--
		50%	#Max	--	--	19.50	--	--	--
		100%	--	--	--	19.48	--	--	--
	16QAM	1	#0	--	--	19.42	--	--	--
		1	#Mid	--	--	15.49	--	--	--
		1	#Max	--	--	19.50	--	--	--
		50%	#0	--	--	19.52	--	--	--
		50%	#Mid	--	--	19.49	--	--	--
		50%	#Max	--	--	19.43	--	--	--
		100%	--	--	--	19.50	--	--	--
	64QAM	1	#0	--	--	19.05	--	--	--
		1	#Mid	--	--	19.08	--	--	--
		1	#Max	--	--	19.05	--	--	--
		50%	#0	--	--	19.07	--	--	--
		50%	#Mid	--	--	19.07	--	--	--
		50%	#Max	--	--	19.04	--	--	--
		100%	--	--	--	19.08	--	--	--
Mid	QPSK	1	#0	--	--	19.44	19.75	--	--
		1	#Mid	--	--	19.45	19.70	--	--
		1	#Max	--	--	19.33	19.41	--	--
		50%	#0	--	--	19.49	19.52	--	--
		50%	#Mid	--	--	19.53	19.52	--	--
		50%	#Max	--	--	19.47	19.48	--	--
		100%	--	--	--	19.50	19.56	--	--
	16QAM	1	#0	--	--	19.43	19.45	--	--
		1	#Mid	--	--	19.41	19.46	--	--
		1	#Max	--	--	19.45	19.35	--	--

		50%	#0	--	--	19.42	19.37	--	--	
		50%	#Mid	--	--	19.44	19.40	--	--	
		50%	#Max	--	--	19.44	19.32	--	--	
		100%	--	--	--	19.46	19.36	--	--	
	64QAM	1	#0	--	--	19.07	19.02	--	--	
		1	#Mid	--	--	19.01	19.01	--	--	
		1	#Max	--	--	19.01	19.01	--	--	
		50%	#0	--	--	19.07	19.07	--	--	
		50%	#Mid	--	--	19.04	19.09	--	--	
		50%	#Max	--	--	19.02	19.06	--	--	
	100%	--	--	--	19.04	19.03	--	--		
	High	QPSK	1	#0	--	--	19.36	--	--	--
			1	#Mid	--	--	19.19	--	--	--
1			#Max	--	--	19.21	--	--	--	
50%			#0	--	--	19.38	--	--	--	
50%			#Mid	--	--	19.37	--	--	--	
50%			#Max	--	--	19.24	--	--	--	
100%			--	--	--	19.34	--	--	--	
16QAM		1	#0	--	--	19.33	--	--	--	
		1	#Mid	--	--	19.38	--	--	--	
		1	#Max	--	--	19.40	--	--	--	
		50%	#0	--	--	19.40	--	--	--	
		50%	#Mid	--	--	19.43	--	--	--	
		50%	#Max	--	--	19.28	--	--	--	
		100%	--	--	--	19.42	--	--	--	
64QAM		1	#0	--	--	19.2	--	--	--	
		1	#Mid	--	--	19.07	--	--	--	
		1	#Max	--	--	19.02	--	--	--	
		50%	#0	--	--	19.06	--	--	--	
		50%	#Mid	--	--	19.09	--	--	--	
		50%	#Max	--	--	19.02	--	--	--	
		100%	--	--	--	19.06	--	--	--	

P-Sensor Off

Channel	Modulation	LTE Band 14							
		RB	RB	Maximum Conducted Output Power					
		No.	Offset	1.4M	3M	5M	10M	15M	20M
Low	QPSK	1	#0	--	--	23.71	--	--	--
		1	#Mid	--	--	23.81	--	--	--
		1	#Max	--	--	23.63	--	--	--
		50%	#0	--	--	22.85	--	--	--
		50%	#Mid	--	--	22.86	--	--	--
		50%	#Max	--	--	22.88	--	--	--
		100%	--	--	--	22.93	--	--	--
	16QAM	1	#0	--	--	22.95	--	--	--
		1	#Mid	--	--	22.92	--	--	--
		1	#Max	--	--	22.95	--	--	--
		50%	#0	--	--	21.96	--	--	--
		50%	#Mid	--	--	21.96	--	--	--
		50%	#Max	--	--	21.86	--	--	--
		100%	--	--	--	21.97	--	--	--
	64QAM	1	#0	--	--	22.91	--	--	--
		1	#Mid	--	--	22.96	--	--	--
		1	#Max	--	--	22.9	--	--	--
		50%	#0	--	--	21.82	--	--	--
		50%	#Mid	--	--	21.9	--	--	--
		50%	#Max	--	--	22.06	--	--	--
		100%	--	--	--	21.95	--	--	--
Mid	QPSK	1	#0	--	--	23.66	24.04	--	--
		1	#Mid	--	--	23.73	23.90	--	--
		1	#Max	--	--	23.68	23.89	--	--
		50%	#0	--	--	22.84	22.95	--	--
		50%	#Mid	--	--	22.90	22.97	--	--
		50%	#Max	--	--	22.87	22.89	--	--
		100%	--	--	--	22.90	23.00	--	--
	16QAM	1	#0	--	--	22.87	23.19	--	--
		1	#Mid	--	--	22.92	23.09	--	--
		1	#Max	--	--	22.88	23.24	--	--

		50%	#0	--	--	21.93	22.06	--	--	
		50%	#Mid	--	--	21.85	21.98	--	--	
		50%	#Max	--	--	21.86	22.08	--	--	
		100%	--	--	--	21.87	21.95	--	--	
	64QAM	1	#0	--	--	22.82	22	--	--	
		1	#Mid	--	--	22.82	22.08	--	--	
		1	#Max	--	--	22.79	22.03	--	--	
		50%	#0	--	--	21.67	20.85	--	--	
		50%	#Mid	--	--	21.74	20.92	--	--	
		50%	#Max	--	--	21.71	20.83	--	--	
	100%	--	--	--	21.92	20.89	--	--		
	High	QPSK	1	#0	--	--	23.66	--	--	--
			1	#Mid	--	--	23.60	--	--	--
1			#Max	--	--	23.64	--	--	--	
50%			#0	--	--	22.77	--	--	--	
50%			#Mid	--	--	22.83	--	--	--	
50%			#Max	--	--	22.71	--	--	--	
100%			--	--	--	22.72	--	--	--	
16QAM		1	#0	--	--	23.17	--	--	--	
		1	#Mid	--	--	23.12	--	--	--	
		1	#Max	--	--	23.15	--	--	--	
		50%	#0	--	--	21.83	--	--	--	
		50%	#Mid	--	--	21.78	--	--	--	
		50%	#Max	--	--	21.78	--	--	--	
		100%	--	--	--	21.86	--	--	--	
64QAM		1	#0	--	--	22.82	--	--	--	
		1	#Mid	--	--	22.82	--	--	--	
		1	#Max	--	--	22.79	--	--	--	
		50%	#0	--	--	21.67	--	--	--	
		50%	#Mid	--	--	21.74	--	--	--	
		50%	#Max	--	--	21.71	--	--	--	
		100%	--	--	--	21.92	--	--	--	

P-Sensor On

Channel	Modulation	LTE Band 14							
		RB	RB	Maximum Conducted Output Power					
		No.	Offset	1.4M	3M	5M	10M	15M	20M
Low	QPSK	1	#0	--	--	19.40	--	--	--
		1	#Mid	--	--	19.50	--	--	--
		1	#Max	--	--	19.56	--	--	--
		50%	#0	--	--	19.43	--	--	--
		50%	#Mid	--	--	19.37	--	--	--
		50%	#Max	--	--	19.34	--	--	--
		100%	--	--	--	19.50	--	--	--
	16QAM	1	#0	--	--	19.59	--	--	--
		1	#Mid	--	--	19.60	--	--	--
		1	#Max	--	--	19.55	--	--	--
		50%	#0	--	--	19.44	--	--	--
		50%	#Mid	--	--	19.39	--	--	--
		50%	#Max	--	--	19.39	--	--	--
		100%	--	--	--	19.52	--	--	--
	64QAM	1	#0	--	--	19.57	--	--	--
		1	#Mid	--	--	19.5	--	--	--
		1	#Max	--	--	19.42	--	--	--
		50%	#0	--	--	19.25	--	--	--
		50%	#Mid	--	--	19.3	--	--	--
		50%	#Max	--	--	19.27	--	--	--
		100%	--	--	--	19.36	--	--	--
Mid	QPSK	1	#0	--	--	19.27	19.78	--	--
		1	#Mid	--	--	19.44	19.65	--	--
		1	#Max	--	--	19.27	19.74	--	--
		50%	#0	--	--	19.36	19.79	--	--
		50%	#Mid	--	--	19.32	19.59	--	--
		50%	#Max	--	--	19.35	19.65	--	--
		100%	--	--	--	19.47	19.77	--	--
	16QAM	1	#0	--	--	19.66	19.67	--	--
		1	#Mid	--	--	19.60	19.60	--	--
		1	#Max	--	--	19.47	19.67	--	--

		50%	#0	--	--	19.47	19.65	--	--	
		50%	#Mid	--	--	19.37	19.58	--	--	
		50%	#Max	--	--	19.41	19.59	--	--	
		100%	--	--	--	19.44	19.70	--	--	
	64QAM	1	#0	--	--	19.51	19.43	--	--	
		1	#Mid	--	--	19.1	19.6	--	--	
		1	#Max	--	--	19.32	19.54	--	--	
		50%	#0	--	--	19.24	19.33	--	--	
		50%	#Mid	--	--	19.3	19.3	--	--	
		50%	#Max	--	--	19.12	19.22	--	--	
		100%	--	--	--	19.32	19.37	--	--	
	High	QPSK	1	#0	--	--	19.28	--	--	--
			1	#Mid	--	--	19.48	--	--	--
1			#Max	--	--	19.53	--	--	--	
50%			#0	--	--	19.39	--	--	--	
50%			#Mid	--	--	19.34	--	--	--	
50%			#Max	--	--	19.38	--	--	--	
100%			--	--	--	19.43	--	--	--	
16QAM		1	#0	--	--	19.76	--	--	--	
		1	#Mid	--	--	19.79	--	--	--	
		1	#Max	--	--	19.67	--	--	--	
		50%	#0	--	--	19.36	--	--	--	
		50%	#Mid	--	--	19.39	--	--	--	
		50%	#Max	--	--	19.51	--	--	--	
		100%	--	--	--	19.45	--	--	--	
64QAM		1	#0	--	--	19.32	--	--	--	
		1	#Mid	--	--	19.53	--	--	--	
		1	#Max	--	--	19.35	--	--	--	
		50%	#0	--	--	19.24	--	--	--	
		50%	#Mid	--	--	19.28	--	--	--	
		50%	#Max	--	--	19.35	--	--	--	
		100%	--	--	--	19.3	--	--	--	

P-Sensor Off

Channel	Modulation	LTE Band 17							
		RB	RB	Maximum Conducted Output Power					
		No.	Offset	1.4M	3M	5M	10M	15M	20M
Low	QPSK	1	#0	--	--	23.30	23.41	--	--
		1	#Mid	--	--	23.42	23.47	--	--
		1	#Max	--	--	23.41	23.48	--	--
		50%	#0	--	--	22.45	22.58	--	--
		50%	#Mid	--	--	22.44	22.55	--	--
		50%	#Max	--	--	22.49	22.56	--	--
		100%	--	--	--	22.50	22.58	--	--
	16QAM	1	#0	--	--	22.47	22.99	--	--
		1	#Mid	--	--	22.60	22.98	--	--
		1	#Max	--	--	22.62	23.12	--	--
		50%	#0	--	--	21.49	21.74	--	--
		50%	#Mid	--	--	21.54	21.70	--	--
		50%	#Max	--	--	21.50	21.74	--	--
		100%	--	--	--	21.47	21.69	--	--
	64QAM	1	#0	--	--	22.32	21.69	--	--
		1	#Mid	--	--	22.22	21.39	--	--
		1	#Max	--	--	22.24	21.79	--	--
		50%	#0	--	--	21.61	20.48	--	--
		50%	#Mid	--	--	21.67	20.6	--	--
		50%	#Max	--	--	21.49	20.53	--	--
		100%	--	--	--	21.6	20.46	--	--
Mid	QPSK	1	#0	--	--	23.44	23.44	--	--
		1	#Mid	--	--	23.45	23.41	--	--
		1	#Max	--	--	23.53	23.76	--	--
		50%	#0	--	--	22.45	22.55	--	--
		50%	#Mid	--	--	22.42	22.61	--	--
		50%	#Max	--	--	22.40	22.55	--	--
		100%	--	--	--	22.43	22.58	--	--
	16QAM	1	#0	--	--	22.88	22.59	--	--
		1	#Mid	--	--	22.64	22.76	--	--
		1	#Max	--	--	22.66	22.87	--	--

		50%	#0	--	--	21.53	21.63	--	--	
		50%	#Mid	--	--	21.60	21.70	--	--	
		50%	#Max	--	--	21.59	21.56	--	--	
		100%	--	--	--	21.57	21.62	--	--	
	64QAM	1	#0	--	--	22.46	21.61	--	--	
		1	#Mid	--	--	22.59	21.4	--	--	
		1	#Max	--	--	22.57	21.56	--	--	
		50%	#0	--	--	21.45	20.47	--	--	
		50%	#Mid	--	--	21.5	20.55	--	--	
		50%	#Max	--	--	21.49	20.51	--	--	
		100%	--	--	--	21.61	20.47	--	--	
	High	QPSK	1	#0	--	--	23.39	23.50	--	--
			1	#Mid	--	--	23.38	23.50	--	--
1			#Max	--	--	23.48	23.59	--	--	
50%			#0	--	--	22.40	22.54	--	--	
50%			#Mid	--	--	22.47	22.58	--	--	
50%			#Max	--	--	22.43	22.68	--	--	
100%			--	--	--	22.50	22.54	--	--	
16QAM		1	#0	--	--	22.66	22.89	--	--	
		1	#Mid	--	--	22.94	23.07	--	--	
		1	#Max	--	--	23.05	23.21	--	--	
		50%	#0	--	--	21.49	21.65	--	--	
		50%	#Mid	--	--	21.47	21.67	--	--	
		50%	#Max	--	--	21.50	21.71	--	--	
		100%	--	--	--	21.56	21.68	--	--	
64QAM		1	#0	--	--	22.59	21.49	--	--	
		1	#Mid	--	--	22.64	21.5	--	--	
		1	#Max	--	--	22.66	21.91	--	--	
		50%	#0	--	--	21.55	20.48	--	--	
		50%	#Mid	--	--	21.68	20.5	--	--	
		50%	#Max	--	--	21.59	20.63	--	--	
		100%	--	--	--	21.53	20.52	--	--	

P-Sensor On

Channel	Modulation	LTE Band 17							
		RB	RB	Maximum Conducted Output Power					
		No.	Offset	1.4M	3M	5M	10M	15M	20M
Low	QPSK	1	#0	--	--	19.08	19.24	--	--
		1	#Mid	--	--	19.09	19.30	--	--
		1	#Max	--	--	19.10	19.36	--	--
		50%	#0	--	--	19.05	19.13	--	--
		50%	#Mid	--	--	19.11	19.12	--	--
		50%	#Max	--	--	19.02	19.24	--	--
		100%	--	--	--	19.08	19.31	--	--
	16QAM	1	#0	--	--	19.12	19.01	--	--
		1	#Mid	--	--	19.06	19.07	--	--
		1	#Max	--	--	19.25	19.38	--	--
		50%	#0	--	--	19.13	19.07	--	--
		50%	#Mid	--	--	19.21	19.07	--	--
		50%	#Max	--	--	19.14	19.11	--	--
		100%	--	--	--	19.13	19.25	--	--
	64QAM	1	#0	--	--	18.85	18.65	--	--
		1	#Mid	--	--	18.84	18.48	--	--
		1	#Max	--	--	18.92	18.88	--	--
		50%	#0	--	--	18.77	18.87	--	--
		50%	#Mid	--	--	18.86	18.85	--	--
		50%	#Max	--	--	18.82	18.88	--	--
		100%	--	--	--	18.69	19.03	--	--
Mid	QPSK	1	#0	--	--	19.06	19.31	--	--
		1	#Mid	--	--	19.03	19.38	--	--
		1	#Max	--	--	19.02	19.86	--	--
		50%	#0	--	--	19.02	19.12	--	--
		50%	#Mid	--	--	19.03	19.06	--	--
		50%	#Max	--	--	19.06	19.25	--	--
		100%	--	--	--	19.01	19.34	--	--
	16QAM	1	#0	--	--	19.05	19.02	--	--
		1	#Mid	--	--	19.09	19.03	--	--
		1	#Max	--	--	19.18	19.17	--	--

		50%	#0	--	--	19.11	19.06	--	--	
		50%	#Mid	--	--	19.11	19.15	--	--	
		50%	#Max	--	--	19.12	19.08	--	--	
		100%	--	--	--	19.07	19.25	--	--	
	64QAM	1	#0	--	--	18.9	18.63	--	--	
		1	#Mid	--	--	18.95	18.77	--	--	
		1	#Max	--	--	19.05	18.91	--	--	
		50%	#0	--	--	18.79	18.81	--	--	
		50%	#Mid	--	--	18.8	18.91	--	--	
		50%	#Max	--	--	18.78	18.89	--	--	
		100%	--	--	--	18.66	18.99	--	--	
	High	QPSK	1	#0	--	--	19.09	19.35	--	--
			1	#Mid	--	--	19.24	19.81	--	--
1			#Max	--	--	19.29	19.83	--	--	
50%			#0	--	--	19.08	19.06	--	--	
50%			#Mid	--	--	19.15	19.04	--	--	
50%			#Max	--	--	19.14	19.35	--	--	
100%			--	--	--	19.16	19.32	--	--	
16QAM		1	#0	--	--	19.04	19.05	--	--	
		1	#Mid	--	--	19.00	19.06	--	--	
		1	#Max	--	--	19.06	19.35	--	--	
		50%	#0	--	--	19.15	19.00	--	--	
		50%	#Mid	--	--	19.07	19.09	--	--	
		50%	#Max	--	--	19.09	19.12	--	--	
		100%	--	--	--	19.02	19.23	--	--	
64QAM		1	#0	--	--	18.92	19.01	--	--	
		1	#Mid	--	--	19.03	19.05	--	--	
		1	#Max	--	--	19.06	19.29	--	--	
		50%	#0	--	--	18.66	18.92	--	--	
		50%	#Mid	--	--	18.81	18.86	--	--	
		50%	#Max	--	--	18.79	18.93	--	--	
		100%	--	--	--	18.76	18.94	--	--	

P-Sensor Off

Channel	Modulation	LTE Band 25								
		RB	RB	Maximum Conducted Output Power						
		No.	Offset	1.4M	3M	5M	10M	15M	20M	
Low	QPSK	1	#0	23.84	23.91	23.75	23.89	24.18	24.25	
		1	#Mid	24.00	24.11	23.77	23.84	24.10	24.21	
		1	#Max	23.91	23.87	23.75	23.78	23.83	24.02	
		50%	#0	22.99	22.99	22.82	22.89	23.08	23.12	
		50%	#Mid	22.96	22.91	22.89	22.89	23.06	23.08	
		50%	#Max	22.89	22.87	22.83	22.84	23.00	23.11	
		100%	--	22.88	22.89	22.80	22.85	23.06	23.26	
	16QAM	1	#0	23.20	23.33	22.69	23.08	23.53	23.55	
		1	#Mid	23.33	23.49	22.64	23.29	23.52	23.44	
		1	#Max	23.35	23.24	22.84	23.20	23.23	23.27	
		50%	#0	22.87	22.04	22.04	21.94	22.22	22.40	
		50%	#Mid	22.91	22.06	21.90	21.83	22.10	22.27	
		50%	#Max	22.84	21.99	21.92	21.88	21.98	22.30	
		100%	--	21.97	21.93	21.91	21.97	22.12	22.30	
	64QAM	1	#0	22.88	22.82	22.91	22.96	22.95	22.33	
		1	#Mid	22.89	22.83	22.69	22.92	22.96	22.24	
		1	#Max	22.9	22.93	22.67	22.76	22.73	22.81	
		50%	#0	22.93	21.81	22.09	21.86	22.01	22.03	
		50%	#Mid	22.91	21.84	21.96	21.87	21.92	20.91	
		50%	#Max	22.91	21.79	21.9	21.82	21.75	20.77	
		100%	--	21.9	21.92	21.93	21.87	21.84	20.84	
	Mid	QPSK	1	#0	23.70	23.64	23.80	23.56	23.93	24.35
			1	#Mid	23.78	23.74	23.84	23.59	24.04	24.15
			1	#Max	23.71	23.73	23.75	23.57	24.11	24.22
50%			#0	22.80	22.78	22.76	22.66	22.97	23.16	
50%			#Mid	22.76	22.87	22.87	22.75	22.95	23.25	
50%			#Max	22.80	22.84	22.75	22.77	23.01	23.47	
100%			--	22.91	22.79	22.89	22.67	23.01	23.06	
16QAM		1	#0	23.27	22.87	22.98	22.71	23.16	23.22	
		1	#Mid	23.20	22.98	22.71	22.86	23.17	23.32	
		1	#Max	23.22	22.91	22.84	22.78	23.28	23.24	

		50%	#0	22.71	21.89	21.91	21.84	22.03	22.13	
		50%	#Mid	22.78	21.98	21.89	21.90	22.07	22.10	
		50%	#Max	22.95	22.02	21.96	21.82	22.13	22.12	
		100%	--	21.91	21.95	21.88	21.69	21.99	22.11	
	64QAM	1	#0	22.76	22.62	22.91	22.73	22.61	22.52	
		1	#Mid	22.87	22.81	22.94	22.79	22.64	22.04	
		1	#Max	22.78	22.65	22.76	22.78	22.66	22.04	
		50%	#0	22.94	21.8	21.73	21.76	21.64	20.83	
		50%	#Mid	22.83	21.79	21.85	21.81	21.65	20.78	
		50%	#Max	22.93	21.73	21.74	21.8	21.72	20.8	
		100%	--	21.83	21.77	21.77	21.69	21.71	20.79	
	High	QPSK	1	#0	23.97	23.99	23.93	23.96	23.91	24.20
			1	#Mid	23.95	24.10	23.99	23.81	24.06	24.11
1			#Max	23.96	23.91	24.02	24.02	24.06	24.11	
50%			#0	22.95	23.03	22.98	22.89	23.00	23.29	
50%			#Mid	22.16	23.02	23.04	22.83	23.07	23.20	
50%			#Max	22.22	23.02	22.95	22.84	23.11	23.14	
100%			--	22.18	23.01	22.97	22.86	23.11	23.18	
16QAM		1	#0	22.96	22.90	23.11	22.70	23.04	23.17	
		1	#Mid	22.92	23.05	23.10	22.68	23.24	23.32	
		1	#Max	22.90	23.11	22.96	22.83	23.41	23.52	
		50%	#0	22.99	22.03	22.03	21.87	22.12	22.25	
		50%	#Mid	22.13	22.04	22.11	21.93	22.09	22.38	
		50%	#Max	22.78	22.01	22.03	21.85	22.16	22.35	
		100%	--	22.20	22.20	21.99	21.85	22.06	22.18	
64QAM		1	#0	23.01	23.17	22.9	22.98	22.81	21.6	
		1	#Mid	23.01	23.24	22.93	22.85	22.99	21.72	
		1	#Max	22.86	23.14	22.99	22.94	22.92	21.72	
		50%	#0	22.93	21.97	21.92	21.87	21.94	20.92	
		50%	#Mid	22.98	21.96	21.99	21.87	21.94	20.96	
		50%	#Max	22.93	21.92	21.92	21.79	21.87	20.95	
		100%	--	21.94	22.02	21.85	21.86	21.97	20.87	

P-Sensor On

Channel	Modulation	LTE Band 25								
		RB	RB	Maximum Conducted Output Power						
		No.	Offset	1.4M	3M	5M	10M	15M	20M	
Low	QPSK	1	#0	15.47	15.50	15.52	15.70	15.51	16.14	
		1	#Mid	15.50	15.54	15.45	15.63	15.52	16.14	
		1	#Max	15.59	15.51	15.51	15.61	15.50	15.98	
		50%	#0	15.57	15.55	15.58	15.65	15.53	16.05	
		50%	#Mid	15.51	15.59	15.57	15.66	15.52	15.66	
		50%	#Max	15.50	15.55	15.56	15.61	15.51	15.59	
		100%	--	15.53	15.55	15.49	15.53	15.50	15.98	
	16QAM	1	#0	15.60	15.94	16.15	15.88	15.53	15.67	
		1	#Mid	15.72	16.01	16.10	15.80	15.59	15.51	
		1	#Max	15.57	15.92	16.09	15.76	15.58	15.56	
		50%	#0	15.68	15.65	15.68	15.71	15.55	15.56	
		50%	#Mid	15.69	15.68	15.71	15.72	15.51	15.56	
		50%	#Max	15.61	15.66	15.66	15.66	15.50	15.52	
		100%	--	15.67	15.68	15.63	15.72	15.56	15.66	
	64QAM	1	#0	15.6	15.64	15.74	15.74	15.77	15.75	
		1	#Mid	15.66	15.61	15.56	15.7	15.7	15.67	
		1	#Max	15.58	15.51	15.51	15.68	15.57	15.62	
		50%	#0	15.52	15.51	15.5	15.58	15.45	15.53	
		50%	#Mid	15.58	15.54	15.5	15.58	15.47	15.51	
		50%	#Max	15.5	15.58	15.47	15.52	15.5	15.52	
		100%	--	15.55	15.5	15.55	15.52	15.5	15.5	
	Mid	QPSK	1	#0	15.50	15.95	15.85	15.79	15.54	16.23
			1	#Mid	15.57	16.02	15.88	16.08	15.56	16.13
			1	#Max	15.51	15.81	15.99	15.97	15.54	16.15
50%			#0	15.55	15.87	15.84	15.80	15.55	16.09	
50%			#Mid	15.58	15.86	15.88	15.90	15.58	15.89	
50%			#Max	15.58	15.81	15.97	15.89	15.57	15.77	
100%			--	15.57	15.82	15.78	15.86	15.50	16.06	
16QAM		1	#0	15.57	16.41	16.30	15.98	15.51	15.86	
		1	#Mid	15.68	16.40	16.33	16.14	15.52	16.06	
		1	#Max	15.60	16.36	16.26	16.19	15.54	16.20	

		50%	#0	15.45	16.09	15.98	15.93	15.57	15.50	
		50%	#Mid	15.50	16.16	16.00	16.00	15.53	15.54	
		50%	#Max	15.45	16.09	16.01	16.00	15.51	15.62	
		100%	--	15.57	16.05	15.95	15.95	15.52	15.65	
	64QAM	1	#0	15.6	15.59	15.51	15.73	15.7	15.67	
		1	#Mid	15.56	15.55	15.5	15.83	15.71	15.69	
		1	#Max	15.58	15.55	15.59	15.76	15.71	15.78	
		50%	#0	15.5	15.59	15.59	15.54	15.55	15.58	
		50%	#Mid	15.58	15.52	15.56	15.51	15.58	15.5	
		50%	#Max	15.54	15.57	15.53	15.58	15.52	15.47	
		100%	--	15.53	15.5	15.54	15.56	15.5	15.52	
	High	QPSK	1	#0	15.84	15.53	15.59	15.52	15.54	16.13
			1	#Mid	15.91	15.70	15.58	15.56	15.58	16.09
1			#Max	15.83	15.56	15.60	15.65	15.63	16.05	
50%			#0	15.92	15.53	15.52	15.54	15.53	16.05	
50%			#Mid	15.90	15.62	15.56	15.60	15.60	15.70	
50%			#Max	15.84	15.57	15.55	15.56	15.56	15.65	
100%			--	15.90	15.55	15.58	15.57	15.53	16.05	
16QAM		1	#0	16.13	16.00	16.27	15.60	15.66	15.73	
		1	#Mid	16.19	16.14	16.00	15.72	15.60	15.89	
		1	#Max	16.02	15.92	16.31	15.69	15.64	16.01	
		50%	#0	16.03	15.74	15.65	15.62	15.52	15.68	
		50%	#Mid	16.04	15.75	15.68	15.73	15.54	15.79	
		50%	#Max	16.00	15.75	15.60	15.69	15.55	15.91	
		100%	--	16.05	15.58	15.65	15.65	15.59	15.75	
64QAM		1	#0	15.78	15.72	15.6	15.78	15.74	15.91	
		1	#Mid	15.84	15.86	15.67	15.94	15.82	15.94	
		1	#Max	15.79	15.71	15.74	16.05	15.67	16.1	
		50%	#0	15.87	15.76	15.73	15.6	15.64	15.56	
		50%	#Mid	15.86	15.79	15.8	15.71	15.65	15.7	
		50%	#Max	15.74	15.76	15.83	15.65	15.76	15.8	
		100%	--	15.64	15.63	15.69	15.68	15.6	15.65	

P-Sensor Off

Channel	Modulation	LTE Band 26							
		RB	RB	Maximum Conducted Output Power					
		No.	Offset	1.4M	3M	5M	10M	15M	20M
Low	QPSK	1	#0	23.66	23.73	23.67	23.80	23.84	--
		1	#Mid	23.77	23.75	23.55	23.69	23.80	--
		1	#Max	23.71	23.74	23.54	23.81	23.77	--
		50%	#0	22.76	22.72	22.75	22.73	22.84	--
		50%	#Mid	22.81	22.80	22.74	22.75	22.86	--
		50%	#Max	22.71	22.73	22.73	22.75	22.83	--
		100%	--	22.73	22.72	22.69	22.77	22.92	--
	16QAM	1	#0	23.03	22.76	22.80	22.61	23.16	--
		1	#Mid	23.16	22.89	22.86	22.73	23.20	--
		1	#Max	23.15	22.81	22.81	22.89	22.88	--
		50%	#0	21.67	21.80	21.85	21.65	21.91	--
		50%	#Mid	21.65	21.93	21.83	21.67	21.97	--
		50%	#Max	21.66	21.83	21.79	21.77	21.94	--
		100%	--	21.79	21.79	21.76	21.90	22.00	--
	64QAM	1	#0	22.66	22.73	22.89	22.87	23.16	--
		1	#Mid	22.96	22.87	22.59	22.82	22.78	--
		1	#Max	23.05	22.75	22.9	22.78	23.09	--
		50%	#0	22.76	21.8	21.95	21.81	21.75	--
		50%	#Mid	22.74	21.77	21.92	21.73	21.88	--
		50%	#Max	22.73	21.74	21.82	21.83	21.77	--
		100%	--	21.9	21.87	21.82	21.84	21.82	--
Mid	QPSK	1	#0	23.49	23.78	23.68	23.68	23.96	--
		1	#Mid	23.55	23.86	23.65	23.55	23.78	--
		1	#Max	23.45	23.56	23.81	23.60	23.77	--
		50%	#0	22.45	22.59	22.64	22.68	22.88	--
		50%	#Mid	22.57	22.73	22.64	22.72	22.76	--
		50%	#Max	22.59	22.66	22.65	22.64	22.85	--
		100%	--	22.63	22.61	22.68	22.64	22.77	--
	16QAM	1	#0	22.83	22.54	22.65	22.72	23.23	--
		1	#Mid	22.91	22.78	22.53	22.70	23.16	--
		1	#Max	22.90	22.69	22.75	22.91	22.91	--

		50%	#0	22.56	21.80	21.71	21.77	21.95	--	
		50%	#Mid	22.60	21.84	21.71	21.70	21.91	--	
		50%	#Max	22.60	21.77	21.62	21.70	21.90	--	
		100%	--	21.86	21.86	21.70	21.73	21.83	--	
	64QAM	1	#0	22.72	22.54	23.15	22.61	22.72	--	
		1	#Mid	22.71	22.72	23.03	22.45	23.15	--	
		1	#Max	22.65	22.62	23.15	23.15	22.77	--	
		50%	#0	22.68	21.64	21.71	21.77	21.74	--	
		50%	#Mid	22.83	21.69	21.7	21.69	21.77	--	
		50%	#Max	22.83	21.61	21.62	21.58	21.76	--	
		100%	--	21.71	21.64	21.7	21.63	21.74	--	
	High	QPSK	1	#0	23.64	23.75	23.66	23.72	23.76	--
			1	#Mid	23.66	23.70	23.73	23.73	23.74	--
1			#Max	23.60	23.69	23.63	23.69	23.71	--	
50%			#0	22.76	22.76	22.81	22.81	22.87	--	
50%			#Mid	22.79	22.71	22.80	22.82	22.86	--	
50%			#Max	22.77	22.74	22.82	22.85	22.85	--	
100%			--	22.92	22.91	22.91	22.82	22.95	--	
16QAM		1	#0	23.10	23.24	23.30	23.28	23.27	--	
		1	#Mid	23.18	23.25	23.32	23.16	23.23	--	
		1	#Max	23.11	22.92	23.09	23.20	23.33	--	
		50%	#0	22.87	22.05	22.00	21.82	21.93	--	
		50%	#Mid	22.99	21.86	22.05	21.99	22.07	--	
		50%	#Max	22.80	21.97	22.03	22.00	22.10	--	
		100%	--	22.01	21.93	21.96	21.96	22.03	--	
64QAM		1	#0	22.72	22.9	23.3	22.95	22.77	--	
		1	#Mid	22.65	23.02	23.37	23.24	22.85	--	
		1	#Max	22.91	23.2	23.18	22.96	23.23	--	
		50%	#0	22.79	22.01	21.94	21.93	21.78	--	
		50%	#Mid	22.89	21.95	21.89	22	21.92	--	
		50%	#Max	22.88	21.97	21.95	21.92	21.95	--	
		100%	--	21.93	21.88	21.96	21.95	21.98	--	

P-Sensor On

Channel	Modulation	LTE Band 26							
		RB	RB	Maximum Conducted Output Power					
		No.	Offset	1.4M	3M	5M	10M	15M	20M
Low	QPSK	1	#0	19.14	19.45	19.43	19.26	19.41	--
		1	#Mid	19.44	19.46	19.38	19.37	19.44	--
		1	#Max	19.37	19.37	19.34	19.40	19.55	--
		50%	#0	19.20	19.33	19.26	19.35	19.47	--
		50%	#Mid	19.44	19.32	19.31	19.36	19.43	--
		50%	#Max	19.36	19.29	19.34	19.46	19.49	--
		100%	--	19.40	19.46	19.48	19.48	19.61	--
	16QAM	1	#0	19.50	19.75	19.71	19.42	19.69	--
		1	#Mid	19.57	19.74	19.71	19.67	19.63	--
		1	#Max	19.59	16.68	19.55	19.71	19.72	--
		50%	#0	19.35	19.55	19.40	19.55	19.54	--
		50%	#Mid	19.59	19.57	19.48	19.50	19.67	--
		50%	#Max	19.49	19.50	19.50	19.56	19.63	--
		100%	--	19.55	19.68	19.52	19.55	19.71	--
	64QAM	1	#0	19.48	19.62	19.4	19.51	19.45	--
		1	#Mid	19.76	19.71	19.51	19.47	19.41	--
		1	#Max	19.67	19.44	19.36	19.62	19.68	--
		50%	#0	19.49	19.35	19.38	19.39	19.29	--
		50%	#Mid	19.63	19.29	19.3	19.43	19.31	--
		50%	#Max	19.58	19.26	19.42	19.49	19.3	--
		100%	--	19.41	19.47	19.49	19.49	19.43	--
Mid	QPSK	1	#0	19.41	19.41	19.43	19.13	19.43	--
		1	#Mid	19.35	19.54	19.30	19.21	19.56	--
		1	#Max	19.33	19.41	19.29	19.32	19.62	--
		50%	#0	19.24	19.35	19.31	19.35	19.50	--
		50%	#Mid	19.39	19.31	19.33	19.29	19.44	--
		50%	#Max	19.32	19.29	19.39	19.28	19.56	--
		100%	--	19.34	19.47	19.40	19.40	19.58	--
	16QAM	1	#0	19.52	19.39	19.73	19.49	19.45	--
		1	#Mid	19.69	19.70	19.74	19.54	19.55	--
		1	#Max	19.58	19.68	19.52	19.67	19.61	--

		50%	#0	19.43	19.54	19.41	19.37	19.59	--	
		50%	#Mid	19.52	19.51	19.42	19.39	19.52	--	
		50%	#Max	19.51	19.45	19.40	19.31	19.51	--	
		100%	--	19.56	19.54	19.48	19.53	19.69	--	
	64QAM	1	#0	19.56	19.36	19.76	19.5	19.57	--	
		1	#Mid	19.72	19.71	19.68	19.65	19.49	--	
		1	#Max	19.64	19.59	19.73	19.58	19.63	--	
		50%	#0	19.18	19.29	19.36	19.27	19.35	--	
		50%	#Mid	19.6	19.34	19.33	19.3	19.36	--	
		50%	#Max	19.51	19.3	19.26	19.27	19.27	--	
		100%	--	19.39	19.43	19.35	19.4	19.32	--	
	High	QPSK	1	#0	19.21	19.46	19.15	19.23	19.42	--
			1	#Mid	19.41	19.53	19.36	19.40	19.27	--
1			#Max	19.34	19.27	19.31	19.23	19.56	--	
50%			#0	19.24	19.34	19.33	19.28	19.42	--	
50%			#Mid	19.38	19.35	19.29	19.31	19.45	--	
50%			#Max	19.36	19.21	19.32	19.38	19.49	--	
100%			--	19.32	19.39	19.43	19.35	19.55	--	
16QAM		1	#0	19.60	19.27	19.68	19.70	19.63	--	
		1	#Mid	19.69	19.60	19.74	19.69	19.49	--	
		1	#Max	19.63	19.19	19.71	19.71	19.39	--	
		50%	#0	19.44	19.42	19.38	19.33	19.47	--	
		50%	#Mid	19.50	19.50	19.47	19.28	19.55	--	
		50%	#Max	19.39	19.47	19.37	19.37	19.52	--	
		100%	--	19.62	19.54	19.52	19.45	19.70	--	
64QAM		1	#0	19.62	19.58	19.51	19.53	19.34	--	
		1	#Mid	19.67	19.65	19.68	19.55	19.57	--	
		1	#Max	19.56	19.22	19.62	19.63	19.36	--	
		50%	#0	19.52	19.27	19.3	19.29	19.2	--	
		50%	#Mid	19.54	19.26	19.29	19.21	19.25	--	
		50%	#Max	19.56	19.3	19.27	19.26	19.21	--	
		100%	--	19.37	19.39	19.37	19.34	19.35	--	

P-Sensor Off

Channel	Modulation	LTE Band 30							
		RB	RB	Maximum Conducted Output Power					
		No.	Offset	1.4M	3M	5M	10M	15M	20M
Low	QPSK	1	#0	--	--	22.47	--	--	--
		1	#Mid	--	--	22.33	--	--	--
		1	#Max	--	--	22.38	--	--	--
		50%	#0	--	--	21.52	--	--	--
		50%	#Mid	--	--	21.52	--	--	--
		50%	#Max	--	--	21.50	--	--	--
		100%	--	--	--	21.37	--	--	--
	16QAM	1	#0	--	--	21.41	--	--	--
		1	#Mid	--	--	21.45	--	--	--
		1	#Max	--	--	21.51	--	--	--
		50%	#0	--	--	20.50	--	--	--
		50%	#Mid	--	--	20.48	--	--	--
		50%	#Max	--	--	20.36	--	--	--
		100%	--	--	--	20.44	--	--	--
	64QAM	1	#0	--	--	22.08	--	--	--
		1	#Mid	--	--	22.09	--	--	--
		1	#Max	--	--	22.03	--	--	--
		50%	#0	--	--	21.04	--	--	--
		50%	#Mid	--	--	21.05	--	--	--
		50%	#Max	--	--	21.04	--	--	--
		100%	--	--	--	21.11	--	--	--
Mid	QPSK	1	#0	--	--	22.44	22.34	--	--
		1	#Mid	--	--	22.57	22.69	--	--
		1	#Max	--	--	22.49	22.21	--	--
		50%	#0	--	--	21.31	21.36	--	--
		50%	#Mid	--	--	21.36	21.41	--	--
		50%	#Max	--	--	21.33	21.35	--	--
		100%	--	--	--	21.36	21.42	--	--
	16QAM	1	#0	--	--	21.63	21.53	--	--
		1	#Mid	--	--	21.69	21.72	--	--
		1	#Max	--	--	21.54	21.81	--	--

		50%	#0	--	--	20.55	20.32	--	--	
		50%	#Mid	--	--	20.66	20.48	--	--	
		50%	#Max	--	--	20.66	20.54	--	--	
		100%	--	--	--	20.61	20.55	--	--	
	64QAM	1	#0	--	--	22.03	22.2	--	--	
		1	#Mid	--	--	22.24	22.37	--	--	
		1	#Max	--	--	22.18	22.32	--	--	
		50%	#0	--	--	21.11	21.31	--	--	
		50%	#Mid	--	--	21.18	21.29	--	--	
		50%	#Max	--	--	21.13	21.22	--	--	
	100%	--	--	--	21.15	21.34	--	--		
	High	QPSK	1	#0	--	--	22.27	--	--	--
			1	#Mid	--	--	22.34	--	--	--
1			#Max	--	--	22.33	--	--	--	
50%			#0	--	--	21.47	--	--	--	
50%			#Mid	--	--	21.49	--	--	--	
50%			#Max	--	--	21.50	--	--	--	
100%			--	--	--	21.36	--	--	--	
16QAM		1	#0	--	--	21.61	--	--	--	
		1	#Mid	--	--	21.97	--	--	--	
		1	#Max	--	--	21.81	--	--	--	
		50%	#0	--	--	20.59	--	--	--	
		50%	#Mid	--	--	20.61	--	--	--	
		50%	#Max	--	--	20.55	--	--	--	
		100%	--	--	--	20.60	--	--	--	
64QAM		1	#0	--	--	22.44	--	--	--	
		1	#Mid	--	--	22.13	--	--	--	
		1	#Max	--	--	22.05	--	--	--	
		50%	#0	--	--	21.14	--	--	--	
		50%	#Mid	--	--	21.15	--	--	--	
		50%	#Max	--	--	21.04	--	--	--	
		100%	--	--	--	21.12	--	--	--	

P-Sensor On

Channel	Modulation	LTE Band 30							
		RB	RB	Maximum Conducted Output Power					
		No.	Offset	1.4M	3M	5M	10M	15M	20M
Low	QPSK	1	#0	--	--	14.54	--	--	--
		1	#Mid	--	--	14.61	--	--	--
		1	#Max	--	--	14.76	--	--	--
		50%	#0	--	--	14.65	--	--	--
		50%	#Mid	--	--	14.72	--	--	--
		50%	#Max	--	--	14.71	--	--	--
		100%	--	--	--	14.65	--	--	--
	16QAM	1	#0	--	--	15.10	--	--	--
		1	#Mid	--	--	15.21	--	--	--
		1	#Max	--	--	15.33	--	--	--
		50%	#0	--	--	14.76	--	--	--
		50%	#Mid	--	--	14.85	--	--	--
		50%	#Max	--	--	14.88	--	--	--
		100%	--	--	--	14.77	--	--	--
	64QAM	1	#0	--	--	14.67	--	--	--
		1	#Mid	--	--	14.75	--	--	--
		1	#Max	--	--	14.88	--	--	--
		50%	#0	--	--	14.39	--	--	--
		50%	#Mid	--	--	14.45	--	--	--
		50%	#Max	--	--	14.48	--	--	--
		100%	--	--	--	14.4	--	--	--
Mid	QPSK	1	#0	--	--	14.72	14.68	--	--
		1	#Mid	--	--	14.75	14.86	--	--
		1	#Max	--	--	14.76	14.85	--	--
		50%	#0	--	--	14.72	14.62	--	--
		50%	#Mid	--	--	14.71	14.80	--	--
		50%	#Max	--	--	14.72	14.77	--	--
		100%	--	--	--	14.75	14.76	--	--
	16QAM	1	#0	--	--	15.38	15.24	--	--
		1	#Mid	--	--	15.41	15.44	--	--
		1	#Max	--	--	15.36	15.52	--	--

		50%	#0	--	--	14.81	14.82	--	--	
		50%	#Mid	--	--	14.89	14.88	--	--	
		50%	#Max	--	--	14.88	14.96	--	--	
		100%	--	--	--	14.90	14.82	--	--	
	64QAM	1	#0	--	--	14.78	14.9	--	--	
		1	#Mid	--	--	14.6	15.08	--	--	
		1	#Max	--	--	14.66	15.07	--	--	
		50%	#0	--	--	14.46	14.51	--	--	
		50%	#Mid	--	--	14.56	14.62	--	--	
		50%	#Max	--	--	14.56	14.68	--	--	
	100%	--	--	--	14.58	14.54	--	--		
	High	QPSK	1	#0	--	--	14.75	--	--	--
			1	#Mid	--	--	14.60	--	--	--
1			#Max	--	--	14.71	--	--	--	
50%			#0	--	--	14.77	--	--	--	
50%			#Mid	--	--	14.70	--	--	--	
50%			#Max	--	--	14.75	--	--	--	
100%			--	--	--	14.76	--	--	--	
16QAM		1	#0	--	--	15.14	--	--	--	
		1	#Mid	--	--	15.00	--	--	--	
		1	#Max	--	--	15.15	--	--	--	
		50%	#0	--	--	14.96	--	--	--	
		50%	#Mid	--	--	14.97	--	--	--	
		50%	#Max	--	--	14.90	--	--	--	
		100%	--	--	--	14.90	--	--	--	
64QAM		1	#0	--	--	14.74	--	--	--	
		1	#Mid	--	--	14.53	--	--	--	
		1	#Max	--	--	14.72	--	--	--	
		50%	#0	--	--	14.54	--	--	--	
		50%	#Mid	--	--	14.61	--	--	--	
		50%	#Max	--	--	14.51	--	--	--	
		100%	--	--	--	14.58	--	--	--	

P-Sensor Off

Channel	Modulation	LTE Band 38							
		RB	RB	Maximum Conducted Output Power					
		No.	Offset	1.4M	3M	5M	10M	15M	20M
Low	QPSK	1	#0	--	--	23.80	23.57	23.63	23.90
		1	#Mid	--	--	23.69	23.57	23.76	23.84
		1	#Max	--	--	23.68	23.59	23.81	23.84
		50%	#0	--	--	22.78	22.78	22.72	23.07
		50%	#Mid	--	--	22.81	22.79	22.74	23.07
		50%	#Max	--	--	22.80	22.77	22.90	23.10
		100%	--	--	--	22.79	22.78	22.86	23.15
	16QAM	1	#0	--	--	23.04	23.09	22.97	23.23
		1	#Mid	--	--	22.94	22.98	22.91	23.22
		1	#Max	--	--	22.84	23.00	23.04	23.32
		50%	#0	--	--	21.87	21.89	21.85	22.11
		50%	#Mid	--	--	21.89	21.89	21.88	22.24
		50%	#Max	--	--	21.86	21.97	21.94	22.23
		100%	--	--	--	21.89	21.86	22.06	22.21
	64QAM	1	#0	--	--	22.9	22.94	22.88	22.11
		1	#Mid	--	--	22.9	22.84	22.91	22.09
		1	#Max	--	--	22.89	22.84	23.06	22.19
		50%	#0	--	--	21.84	21.85	21.86	21.12
		50%	#Mid	--	--	21.86	21.86	21.99	21.35
		50%	#Max	--	--	21.81	21.83	22.05	21.22
		100%	--	--	--	21.81	21.82	22.01	21.33
Mid	QPSK	1	#0	--	--	23.65	23.65	23.65	23.98
		1	#Mid	--	--	23.62	23.68	23.75	23.87
		1	#Max	--	--	23.55	23.62	23.76	23.85
		50%	#0	--	--	22.65	22.79	22.87	23.14
		50%	#Mid	--	--	22.81	22.72	22.79	23.05
		50%	#Max	--	--	22.72	22.72	22.87	23.04
		100%	--	--	--	22.76	22.81	22.82	23.08
	16QAM	1	#0	--	--	22.98	23.07	23.09	23.21
		1	#Mid	--	--	22.86	22.89	23.09	23.23
		1	#Max	--	--	22.92	22.94	23.11	23.21

		50%	#0	--	--	21.87	21.89	21.90	22.12	
		50%	#Mid	--	--	21.92	21.93	21.92	22.16	
		50%	#Max	--	--	21.94	21.92	21.91	22.10	
		100%	--	--	--	21.82	21.89	21.98	22.18	
	64QAM	1	#0	--	--	22.92	22.9	22.89	22.01	
		1	#Mid	--	--	22.87	22.83	22.88	22.18	
		1	#Max	--	--	22.96	22.88	22.91	21.99	
		50%	#0	--	--	21.81	21.86	21.9	21.11	
		50%	#Mid	--	--	21.84	21.9	21.93	21.14	
		50%	#Max	--	--	21.85	21.88	21.9	21.12	
	100%	--	--	--	21.8	21.85	21.98	21.1		
	High	QPSK	1	#0	--	--	23.61	23.59	23.62	23.83
			1	#Mid	--	--	23.51	23.40	23.63	23.80
1			#Max	--	--	23.45	23.42	23.60	23.82	
50%			#0	--	--	22.75	22.68	22.76	22.99	
50%			#Mid	--	--	22.68	22.71	22.79	23.02	
50%			#Max	--	--	22.74	22.68	22.76	23.02	
100%			--	--	--	22.61	22.68	22.79	23.01	
16QAM		1	#0	--	--	22.82	22.91	23.06	23.21	
		1	#Mid	--	--	22.84	22.82	22.98	23.16	
		1	#Max	--	--	22.81	22.83	22.95	23.14	
		50%	#0	--	--	21.74	21.78	21.80	22.09	
		50%	#Mid	--	--	21.78	21.81	21.83	22.09	
		50%	#Max	--	--	21.73	21.78	21.79	22.07	
		100%	--	--	--	21.75	21.77	21.87	22.07	
64QAM		1	#0	--	--	22.84	22.86	22.86	21.99	
		1	#Mid	--	--	22.87	22.66	22.88	22.06	
		1	#Max	--	--	22.82	22.76	22.76	21.91	
		50%	#0	--	--	21.79	21.75	21.9	21.09	
		50%	#Mid	--	--	21.84	21.77	21.83	21.12	
		50%	#Max	--	--	21.7	21.74	21.89	21.09	
		100%	--	--	--	21.78	21.72	21.84	21.07	

P-Sensor On

Channel	Modulation	LTE Band 38							
		RB	RB	Maximum Conducted Output Power					
		No.	Offset	1.4M	3M	5M	10M	15M	20M
Low	QPSK	1	#0	--	--	18.01	18.26	18.02	18.70
		1	#Mid	--	--	18.13	18.04	18.15	18.62
		1	#Max	--	--	18.08	18.09	18.06	18.42
		50%	#0	--	--	18.00	18.10	18.17	18.39
		50%	#Mid	--	--	18.11	18.14	18.22	18.45
		50%	#Max	--	--	18.03	18.03	18.06	18.44
		100%	--	--	--	18.22	18.23	18.23	18.60
	16QAM	1	#0	--	--	18.33	18.62	18.33	18.16
		1	#Mid	--	--	18.05	18.19	18.50	18.22
		1	#Max	--	--	18.09	18.14	18.40	18.00
		50%	#0	--	--	18.18	18.20	18.24	18.38
		50%	#Mid	--	--	18.18	18.29	18.30	18.52
		50%	#Max	--	--	18.16	18.12	18.22	18.35
		100%	--	--	--	18.39	18.37	18.43	18.49
	64QAM	1	#0	--	--	18.12	18.42	18.32	18.34
		1	#Mid	--	--	18.39	18.01	18.32	18.19
		1	#Max	--	--	18.69	18.03	18.29	18.51
		50%	#0	--	--	18.13	18.17	18.27	18.17
		50%	#Mid	--	--	18.13	18.23	18.33	18.34
		50%	#Max	--	--	18.13	18.17	18.28	18.21
		100%	--	--	--	18.33	18.3	18.37	18.42
Mid	QPSK	1	#0	--	--	18.04	18.19	18.01	18.73
		1	#Mid	--	--	18.09	18.04	18.40	18.30
		1	#Max	--	--	18.01	18.65	18.53	18.36
		50%	#0	--	--	18.02	18.18	18.13	18.26
		50%	#Mid	--	--	18.01	18.17	18.24	18.65
		50%	#Max	--	--	18.03	18.12	18.10	18.25
		100%	--	--	--	18.13	18.29	18.32	18.38
	16QAM	1	#0	--	--	18.45	18.39	18.27	18.66
		1	#Mid	--	--	18.48	18.70	18.47	18.49
		1	#Max	--	--	18.27	18.65	18.52	18.71

		50%	#0	--	--	18.15	18.12	18.19	18.37	
		50%	#Mid	--	--	18.12	18.20	18.17	18.56	
		50%	#Max	--	--	18.12	18.17	18.12	18.41	
		100%	--	--	--	18.32	18.32	18.33	18.51	
	64QAM	1	#0	--	--	18.35	18.16	18.36	17.8	
		1	#Mid	--	--	18.33	18.55	18.37	17.98	
		1	#Max	--	--	18.14	18.48	18.48	18.11	
		50%	#0	--	--	18.12	18.14	18.23	18.1	
		50%	#Mid	--	--	18.1	18.12	18.2	18.29	
		50%	#Max	--	--	18.13	18.06	18.16	18.11	
	100%	--	--	--	18.27	18.25	18.34	18.35		
	High	QPSK	1	#0	--	--	18.16	18.01	18.37	18.71
			1	#Mid	--	--	18.61	18.09	18.60	18.36
1			#Max	--	--	18.40	18.30	18.61	18.70	
50%			#0	--	--	18.43	18.02	18.19	18.36	
50%			#Mid	--	--	18.51	18.02	18.37	18.57	
50%			#Max	--	--	18.49	18.01	18.30	18.48	
100%			--	--	--	18.54	18.14	18.44	18.51	
16QAM		1	#0	--	--	18.08	18.57	18.03	18.35	
		1	#Mid	--	--	18.22	18.14	18.11	18.18	
		1	#Max	--	--	18.08	18.36	18.32	18.29	
		50%	#0	--	--	18.29	18.30	18.03	18.27	
		50%	#Mid	--	--	18.30	18.32	18.04	18.46	
		50%	#Max	--	--	18.34	18.31	18.01	18.30	
		100%	--	--	--	18.33	18.44	18.21	18.43	
64QAM		1	#0	--	--	18.08	18.47	18.36	18.22	
		1	#Mid	--	--	18.46	18.33	18.6	18.32	
		1	#Max	--	--	18.29	18.79	18.57	18.45	
		50%	#0	--	--	18.42	18.26	18.28	18.15	
		50%	#Mid	--	--	18.35	18.31	18.36	18.3	
		50%	#Max	--	--	18.27	18.22	18.32	18.26	
		100%	--	--	--	18.42	18.35	18.45	18.4	

P-Sensor Off

Channel	Modulation	LTE Band 41							
		RB	RB	Maximum Conducted Output Power					
		No.	Offset	1.4M	3M	5M	10M	15M	20M
Low	QPSK	1	#0	--	--	24.05	24.06	24.04	24.15
		1	#Mid	--	--	24.06	23.98	24.05	24.13
		1	#Max	--	--	23.98	24.00	24.05	24.09
		50%	#0	--	--	23.09	23.06	23.06	23.26
		50%	#Mid	--	--	23.09	23.10	23.09	23.28
		50%	#Max	--	--	23.09	23.03	23.07	23.27
		100%	--	--	--	23.08	23.08	23.08	23.26
	16QAM	1	#0	--	--	23.14	23.16	23.19	23.32
		1	#Mid	--	--	23.11	23.13	23.22	23.33
		1	#Max	--	--	23.11	23.13	23.15	23.26
		50%	#0	--	--	22.11	22.17	22.12	22.33
		50%	#Mid	--	--	22.16	22.18	22.19	22.40
		50%	#Max	--	--	22.09	22.11	22.15	22.37
		100%	--	--	--	22.16	22.15	22.17	22.37
	64QAM	1	#0	--	--	22.09	22.07	21.86	21.93
		1	#Mid	--	--	22.17	21.98	22	21.96
		1	#Max	--	--	22.06	21.93	22.11	21.89
		50%	#0	--	--	21.32	21.28	21.35	21.44
		50%	#Mid	--	--	21.4	21.38	21.35	21.43
		50%	#Max	--	--	21.31	21.29	21.36	21.42
		100%	--	--	--	21.49	21.19	21.44	21.37
Mid	QPSK	1	#0	--	--	24.00	24.03	24.00	24.22
		1	#Mid	--	--	24.01	23.99	24.06	24.21
		1	#Max	--	--	23.94	24.03	23.99	24.15
		50%	#0	--	--	23.01	23.04	23.04	23.31
		50%	#Mid	--	--	23.07	23.06	23.09	23.15
		50%	#Max	--	--	23.03	23.02	23.04	23.17
		100%	--	--	--	23.02	23.03	23.07	23.21
	16QAM	1	#0	--	--	23.07	23.17	23.10	23.20
		1	#Mid	--	--	23.11	23.12	23.14	23.17
		1	#Max	--	--	23.07	23.10	23.09	23.16

		50%	#0	--	--	22.07	22.13	22.09	22.23	
		50%	#Mid	--	--	22.08	22.13	22.11	22.23	
		50%	#Max	--	--	22.04	22.10	22.08	22.24	
		100%	--	--	--	22.10	22.17	22.14	22.24	
	64QAM	1	#0	--	--	21.87	21.98	21.86	21.82	
		1	#Mid	--	--	21.96	21.87	22.02	22.01	
		1	#Max	--	--	21.89	21.8	22.06	21.81	
		50%	#0	--	--	21.11	21.26	21.19	21.32	
		50%	#Mid	--	--	21.13	21.27	21.2	21.23	
		50%	#Max	--	--	21.2	21.25	21.17	21.3	
		100%	--	--	--	21.23	21.22	21.31	21.28	
	High	QPSK	1	#0	--	--	23.48	23.62	23.62	23.80
			1	#Mid	--	--	23.66	23.49	23.79	23.63
1			#Max	--	--	23.56	23.60	23.64	23.70	
50%			#0	--	--	22.59	22.71	22.71	22.66	
50%			#Mid	--	--	22.70	22.71	22.68	22.80	
50%			#Max	--	--	22.71	22.68	22.67	22.77	
100%			--	--	--	22.66	22.73	22.67	22.67	
16QAM		1	#0	--	--	22.61	22.83	22.76	22.82	
		1	#Mid	--	--	22.87	22.59	22.90	22.84	
		1	#Max	--	--	22.68	22.70	22.78	22.80	
		50%	#0	--	--	21.68	21.80	21.78	21.79	
		50%	#Mid	--	--	21.78	21.79	21.75	21.93	
		50%	#Max	--	--	21.78	21.80	21.76	21.86	
		100%	--	--	--	21.79	21.82	21.78	21.78	
64QAM		1	#0	--	--	21.39	21.54	21.7	21.7	
		1	#Mid	--	--	21.68	21.47	21.84	21.48	
		1	#Max	--	--	21.33	21.47	21.53	21.42	
		50%	#0	--	--	20.81	21.02	20.9	20.83	
		50%	#Mid	--	--	20.8	21.01	20.93	20.97	
		50%	#Max	--	--	20.9	21	20.9	20.91	
		100%	--	--	--	20.87	20.97	20.99	20.89	

P-Sensor On

Channel	Modulation	LTE Band 41							
		RB	RB	Maximum Conducted Output Power					
		No.	Offset	1.4M	3M	5M	10M	15M	20M
Low	QPSK	1	#0	--	--	18.06	18.26	18.02	18.32
		1	#Mid	--	--	18.11	18.10	18.03	18.13
		1	#Max	--	--	18.03	18.05	18.16	18.75
		50%	#0	--	--	18.02	18.07	18.07	18.21
		50%	#Mid	--	--	18.08	18.09	18.04	18.68
		50%	#Max	--	--	18.07	18.06	18.02	18.26
		100%	--	--	--	18.13	18.11	18.14	18.69
	16QAM	1	#0	--	--	18.37	18.18	18.14	18.41
		1	#Mid	--	--	18.39	18.35	18.28	18.43
		1	#Max	--	--	18.03	18.06	18.24	18.44
		50%	#0	--	--	18.12	18.18	18.09	18.33
		50%	#Mid	--	--	18.15	18.10	18.12	18.41
		50%	#Max	--	--	18.10	18.09	18.04	18.42
		100%	--	--	--	18.28	18.30	18.31	18.57
	64QAM	1	#0	--	--	18.26	18	18.01	18.4
		1	#Mid	--	--	18.04	18.02	18.08	18.03
		1	#Max	--	--	18.06	18.09	18	18.13
		50%	#0	--	--	18.15	18.24	18.18	18.15
		50%	#Mid	--	--	18.12	18.23	18.19	18.34
		50%	#Max	--	--	18.21	18.15	18.14	18.28
		100%	--	--	--	18.38	18.31	18.34	18.46
Mid	QPSK	1	#0	--	--	18.06	18.22	18.42	18.21
		1	#Mid	--	--	18.28	18.16	18.60	18.32
		1	#Max	--	--	18.17	18.27	18.15	18.85
		50%	#0	--	--	18.23	18.14	18.19	18.39
		50%	#Mid	--	--	18.16	18.19	18.28	18.66
		50%	#Max	--	--	18.14	18.14	18.25	18.42
		100%	--	--	--	18.32	18.36	18.34	18.70
	16QAM	1	#0	--	--	18.37	18.21	18.37	18.33
		1	#Mid	--	--	18.53	18.47	18.51	18.74
		1	#Max	--	--	18.35	18.55	18.46	18.70

		50%	#0	--	--	18.30	18.26	18.34	18.59	
		50%	#Mid	--	--	18.31	18.39	18.45	18.71	
		50%	#Max	--	--	18.29	18.34	18.37	18.58	
		100%	--	--	--	18.47	18.46	18.50	18.72	
	64QAM	1	#0	--	--	18.06	18.22	18.04	18.21	
		1	#Mid	--	--	18.27	18.04	18.23	18.31	
		1	#Max	--	--	18.09	18.05	18.03	18.27	
		50%	#0	--	--	18.26	18.39	18.45	18.41	
		50%	#Mid	--	--	18.37	18.46	18.45	18.53	
		50%	#Max	--	--	18.36	18.43	18.37	18.37	
	100%	--	--	--	18.53	18.47	18.52	18.52		
	High	QPSK	1	#0	--	--	18.28	18.28	18.33	18.35
			1	#Mid	--	--	18.43	18.30	18.43	18.39
1			#Max	--	--	18.16	18.16	18.07	18.67	
50%			#0	--	--	18.40	18.32	18.36	18.44	
50%			#Mid	--	--	18.38	18.44	18.28	18.65	
50%			#Max	--	--	18.20	18.32	18.26	18.50	
100%			--	--	--	18.41	18.44	18.46	18.57	
16QAM		1	#0	--	--	18.55	18.50	18.49	18.64	
		1	#Mid	--	--	18.60	18.42	18.60	18.47	
		1	#Max	--	--	18.42	18.43	18.32	18.51	
		50%	#0	--	--	18.48	18.42	18.49	18.53	
		50%	#Mid	--	--	18.40	18.49	18.40	18.65	
		50%	#Max	--	--	18.32	18.48	18.41	18.67	
		100%	--	--	--	18.60	18.50	18.56	18.66	
64QAM		1	#0	--	--	18.3	18.32	18.23	18.4	
		1	#Mid	--	--	18.38	18.15	18.17	18.22	
		1	#Max	--	--	18.07	18.29	18	18.03	
		50%	#0	--	--	18.41	18.45	18.5	18.39	
		50%	#Mid	--	--	18.4	18.64	18.41	18.58	
		50%	#Max	--	--	18.34	18.56	18.41	18.38	
		100%	--	--	--	18.6	18.59	18.58	18.48	

P-Sensor Off

Channel	Modulation	LTE Band 41 (PC2)							
		RB	RB	Maximum Conducted Output Power					
		No.	Offset	1.4M	3M	5M	10M	15M	20M
Low	QPSK	1	#0	--	--	25.96	25.95	25.98	26.05
		1	#Mid	--	--	25.95	25.90	25.97	26.03
		1	#Max	--	--	25.92	25.95	25.93	26.01
		50%	#0	--	--	25.10	25.06	25.05	25.22
		50%	#Mid	--	--	25.13	25.07	25.05	25.21
		50%	#Max	--	--	25.09	25.07	25.03	25.27
		100%	--	--	--	25.06	25.12	25.09	25.31
	16QAM	1	#0	--	--	25.14	25.16	25.15	25.36
		1	#Mid	--	--	25.12	25.11	25.13	25.42
		1	#Max	--	--	25.09	25.13	25.07	25.38
		50%	#0	--	--	24.15	24.15	24.08	24.43
		50%	#Mid	--	--	24.15	24.14	24.09	24.40
		50%	#Max	--	--	24.16	24.13	24.06	24.41
		100%	--	--	--	24.15	24.10	24.14	24.43
	64QAM	1	#0	--	--	25.09	25.1	25.02	24.08
		1	#Mid	--	--	25.05	25	24.85	24.31
		1	#Max	--	--	24.93	24.96	24.87	24.14
		50%	#0	--	--	24.04	23.98	23.99	23.26
		50%	#Mid	--	--	24.01	23.97	24.08	23.34
		50%	#Max	--	--	24.01	23.97	24.08	23.21
		100%	--	--	--	24.04	23.99	24.06	23.25
Mid	QPSK	1	#0	--	--	25.91	25.97	25.95	26.06
		1	#Mid	--	--	25.93	25.91	26.00	26.06
		1	#Max	--	--	25.86	25.92	25.93	26.05
		50%	#0	--	--	25.05	25.04	25.03	25.26
		50%	#Mid	--	--	25.06	25.06	25.05	25.30
		50%	#Max	--	--	25.06	25.04	25.02	25.28
		100%	--	--	--	25.02	25.04	25.05	25.32
	16QAM	1	#0	--	--	25.12	25.21	25.13	25.31
		1	#Mid	--	--	25.17	25.11	25.16	25.32
		1	#Max	--	--	25.10	25.20	25.11	25.27

		50%	#0	--	--	24.09	24.11	24.09	24.33	
		50%	#Mid	--	--	24.15	24.14	24.09	24.39	
		50%	#Max	--	--	24.11	24.09	24.06	24.36	
		100%	--	--	--	24.09	24.15	24.13	24.33	
	64QAM	1	#0	--	--	24.97	25.06	24.94	24.1	
		1	#Mid	--	--	25.01	24.95	24.97	24.13	
		1	#Max	--	--	24.93	24.99	24.96	24.09	
		50%	#0	--	--	23.94	23.98	24.07	23.19	
		50%	#Mid	--	--	23.97	23.99	23.98	23.29	
		50%	#Max	--	--	23.93	23.97	24.06	23.15	
		100%	--	--	--	23.91	23.97	24.03	23.24	
	High	QPSK	1	#0	--	--	25.37	25.47	25.52	25.69
			1	#Mid	--	--	25.55	25.34	25.62	25.55
1			#Max	--	--	25.41	25.45	25.53	25.59	
50%			#0	--	--	24.62	24.73	24.66	24.85	
50%			#Mid	--	--	24.75	24.67	24.66	24.95	
50%			#Max	--	--	24.76	24.69	24.63	24.90	
100%			--	--	--	24.68	24.74	24.70	24.79	
16QAM		1	#0	--	--	24.59	24.76	24.69	24.85	
		1	#Mid	--	--	24.77	24.61	24.82	24.84	
		1	#Max	--	--	24.66	24.74	24.73	24.91	
		50%	#0	--	--	23.69	23.80	23.74	23.91	
		50%	#Mid	--	--	23.81	23.79	23.75	24.01	
		50%	#Max	--	--	23.83	23.75	23.71	23.95	
		100%	--	--	--	23.78	23.83	23.78	23.87	
64QAM		1	#0	--	--	24.56	24.65	24.72	23.61	
		1	#Mid	--	--	24.71	24.41	24.84	23.77	
		1	#Max	--	--	24.57	24.56	24.55	23.73	
		50%	#0	--	--	23.58	23.62	23.69	22.83	
		50%	#Mid	--	--	23.71	23.61	23.61	22.96	
		50%	#Max	--	--	23.63	23.58	23.68	22.89	
		100%	--	--	--	23.62	23.58	23.66	22.78	

P-Sensor On

Channel	Modulation	LTE Band 41 (PC2)							
		RB	RB	Maximum Conducted Output Power					
		No.	Offset	1.4M	3M	5M	10M	15M	20M
Low	QPSK	1	#0	--	--	20.17	20.02	20.10	20.32
		1	#Mid	--	--	20.03	20.08	20.15	20.90
		1	#Max	--	--	20.07	20.07	20.01	20.34
		50%	#0	--	--	20.01	20.01	20.14	20.43
		50%	#Mid	--	--	20.07	20.04	20.05	20.88
		50%	#Max	--	--	20.01	20.08	20.03	20.46
		100%	--	--	--	20.16	20.13	20.14	20.79
	16QAM	1	#0	--	--	20.59	20.45	20.54	20.49
		1	#Mid	--	--	20.47	20.44	20.31	20.50
		1	#Max	--	--	20.35	20.05	20.55	20.46
		50%	#0	--	--	20.16	20.26	20.21	20.39
		50%	#Mid	--	--	20.15	20.24	20.22	20.52
		50%	#Max	--	--	20.20	20.18	20.21	20.42
		100%	--	--	--	20.27	20.26	20.31	20.57
	64QAM	1	#0	--	--	20.57	20.29	20.32	20.28
		1	#Mid	--	--	20.28	20.05	20.53	20.07
		1	#Max	--	--	20.2	19.9	20.26	20.23
		50%	#0	--	--	20.03	20.21	20.21	20.18
		50%	#Mid	--	--	20.15	20.16	20.24	20.26
		50%	#Max	--	--	20.13	20.15	20.2	20.19
		100%	--	--	--	20.22	20.23	20.3	20.42
Mid	QPSK	1	#0	--	--	20.05	20.20	20.29	20.52
		1	#Mid	--	--	20.18	20.06	20.45	20.96
		1	#Max	--	--	20.02	20.01	20.36	20.41
		50%	#0	--	--	20.15	20.15	20.29	20.47
		50%	#Mid	--	--	20.26	20.32	20.29	20.75
		50%	#Max	--	--	20.20	20.20	20.29	20.48
		100%	--	--	--	20.30	20.35	20.35	20.77
	16QAM	1	#0	--	--	20.16	20.47	20.33	20.85
		1	#Mid	--	--	20.57	20.13	20.41	20.65
		1	#Max	--	--	20.40	20.18	20.46	20.65

		50%	#0	--	--	20.31	20.28	20.41	20.59	
		50%	#Mid	--	--	20.42	20.38	20.35	20.70	
		50%	#Max	--	--	20.38	20.41	20.39	20.58	
		100%	--	--	--	20.45	20.45	20.48	20.64	
	64QAM	1	#0	--	--	20.09	20.5	20.5	20.47	
		1	#Mid	--	--	20.4	20.27	20.73	20.51	
		1	#Max	--	--	20.27	20.19	20.61	20.43	
		50%	#0	--	--	20.24	20.31	20.35	20.34	
		50%	#Mid	--	--	20.28	20.39	20.39	20.45	
		50%	#Max	--	--	20.25	20.33	20.39	20.33	
	100%	--	--	--	20.35	20.41	20.45	20.49		
	High	QPSK	1	#0	--	--	20.37	20.66	20.39	20.48
			1	#Mid	--	--	20.39	20.19	20.80	20.89
1			#Max	--	--	20.29	20.03	20.30	20.33	
50%			#0	--	--	20.47	20.35	20.36	20.42	
50%			#Mid	--	--	20.47	20.36	20.42	20.66	
50%			#Max	--	--	20.27	20.42	20.40	20.55	
100%			--	--	--	20.41	20.47	20.43	20.56	
16QAM		1	#0	--	--	20.65	20.53	20.60	20.75	
		1	#Mid	--	--	20.50	20.57	20.67	20.49	
		1	#Max	--	--	20.51	20.31	20.60	20.48	
		50%	#0	--	--	20.56	20.50	20.45	20.58	
		50%	#Mid	--	--	20.59	20.55	20.47	20.81	
		50%	#Max	--	--	20.41	20.56	20.46	20.70	
		100%	--	--	--	20.61	20.59	20.55	20.70	
64QAM		1	#0	--	--	20.53	20.83	20.53	20.57	
		1	#Mid	--	--	20.66	20.53	20.62	20.48	
		1	#Max	--	--	20.52	20.15	20.49	20.21	
		50%	#0	--	--	20.49	20.44	20.44	20.31	
		50%	#Mid	--	--	20.53	20.52	20.52	20.56	
		50%	#Max	--	--	20.42	20.44	20.46	20.43	
		100%	--	--	--	20.51	20.49	20.58	20.55	

P-Sensor Off

Channel	Modulation	LTE Band 66							
		RB	RB	Maximum Conducted Output Power					
		No.	Offset	1.4M	3M	5M	10M	15M	20M
Low	QPSK	1	#0	23.87	23.82	23.91	23.94	23.95	23.96
		1	#Mid	23.86	23.91	23.90	23.93	23.92	23.95
		1	#Max	23.87	23.81	23.86	23.85	23.87	23.81
		50%	#0	22.78	22.79	22.70	22.89	22.89	22.90
		50%	#Mid	22.39	22.00	22.81	22.90	22.88	22.81
		50%	#Max	22.09	22.70	22.85	22.90	22.81	22.92
		100%	--	22.81	22.81	22.86	22.87	22.82	22.89
	16QAM	1	#0	23.13	23.06	23.34	23.29	23.11	23.40
		1	#Mid	23.10	23.26	23.30	23.33	23.08	23.38
		1	#Max	22.99	23.11	23.29	23.35	23.02	23.31
		50%	#0	22.93	21.98	22.04	22.11	22.12	22.11
		50%	#Mid	22.98	22.01	22.12	22.09	22.05	22.10
		50%	#Max	22.89	21.99	22.06	22.08	22.06	22.01
		100%	--	22.04	22.07	22.05	22.15	22.04	22.00
	64QAM	1	#0	22.1	22.18	22.15	22.23	22.24	22.18
		1	#Mid	22.1	22.27	22.13	22.24	22.23	22.19
		1	#Max	22.07	22.12	22.1	22.26	22.21	22.22
		50%	#0	22.13	21.11	21.12	21.21	21.22	21.21
		50%	#Mid	22.12	21.15	21.18	21.2	21.22	21.18
		50%	#Max	22.09	21.16	21.16	21.17	21.15	21.11
		100%	--	21.03	21.13	21.08	21.17	21.14	21.13
Mid	QPSK	1	#0	23.65	23.69	23.83	23.82	23.85	23.99
		1	#Mid	23.75	23.79	23.83	23.78	23.75	23.74
		1	#Max	23.67	23.68	23.79	23.73	23.74	23.72
		50%	#0	22.45	22.83	22.83	22.85	22.86	22.95
		50%	#Mid	22.27	22.84	22.87	22.88	22.87	22.88
		50%	#Max	22.37	22.81	22.83	22.78	22.79	22.80
		100%	--	22.56	22.84	22.81	22.85	22.84	22.84
	16QAM	1	#0	22.94	22.99	22.94	23.27	22.83	23.07
		1	#Mid	22.99	23.15	22.98	23.26	22.77	23.11
		1	#Max	22.96	22.94	22.95	23.26	22.73	23.04

		50%	#0	22.07	21.84	21.95	22.00	21.95	21.99	
		50%	#Mid	22.06	21.86	22.01	21.96	21.98	21.99	
		50%	#Max	22.08	21.83	21.90	21.94	21.91	21.91	
		100%	--	22.02	21.89	21.97	21.98	21.89	21.96	
	64QAM	1	#0	21.9	22	22.29	22.11	22.15	22.12	
		1	#Mid	22.05	22.09	22.31	22.21	22.2	22.16	
		1	#Max	21.99	22.05	22.25	22.12	22.02	22.17	
		50%	#0	21.93	20.98	21.21	21.02	21.1	21.09	
		50%	#Mid	22.01	21.03	21.24	21.06	21.07	21.06	
		50%	#Max	21.99	20.93	21.2	20.99	21.02	20.98	
	100%	--	20.83	20.92	21.16	21.04	21.01	21.03		
	High	QPSK	1	#0	23.91	23.83	23.91	23.89	23.79	23.76
			1	#Mid	23.94	23.80	23.94	23.77	23.85	23.95
1			#Max	23.89	23.85	23.86	23.71	23.71	23.68	
50%			#0	22.71	22.86	22.70	22.84	22.80	22.88	
50%			#Mid	22.73	22.86	22.69	22.81	22.85	22.84	
50%			#Max	22.78	22.87	22.66	22.86	22.83	22.89	
100%			--	22.72	22.89	22.79	22.88	22.83	22.80	
16QAM		1	#0	23.07	23.18	22.82	23.12	22.91	23.15	
		1	#Mid	23.18	23.28	22.85	23.15	22.99	23.36	
		1	#Max	23.07	23.12	22.77	22.99	22.87	23.01	
		50%	#0	22.97	21.99	21.98	22.03	21.94	21.99	
		50%	#Mid	22.60	22.05	22.05	22.04	22.01	21.96	
		50%	#Max	22.59	21.98	21.97	21.97	21.99	21.99	
		100%	--	22.07	21.85	21.95	22.02	21.90	21.88	
64QAM		1	#0	21.96	22.04	22.17	22.16	22.21	22.14	
		1	#Mid	22.1	22.24	22.16	22.2	22.25	22.23	
		1	#Max	22.04	22.14	22.15	22.12	22.07	22.13	
		50%	#0	22.15	21.11	21.11	21.01	21.08	21.08	
		50%	#Mid	22.15	21.15	21.12	21.12	21.16	21.04	
		50%	#Max	22.09	21.09	21.1	21.09	21.12	21.07	
		100%	--	21.01	21.12	21.08	20.99	21.04	21.02	

P-Sensor On

Channel	Modulation	LTE Band 66							
		RB	RB	Maximum Conducted Output Power					
		No.	Offset	1.4M	3M	5M	10M	15M	20M
Low	QPSK	1	#0	15.62	15.57	15.61	15.63	15.51	15.81
		1	#Mid	15.66	15.68	15.62	15.54	15.57	15.73
		1	#Max	15.56	15.55	15.53	15.49	15.50	15.58
		50%	#0	15.63	15.60	15.64	15.63	15.59	15.80
		50%	#Mid	15.68	15.64	15.65	15.64	15.62	15.80
		50%	#Max	15.63	15.62	15.62	15.54	15.57	15.70
		100%	--	15.62	15.61	15.61	15.63	15.57	15.74
	16QAM	1	#0	15.67	15.64	15.58	15.66	15.54	15.70
		1	#Mid	15.71	15.68	15.60	15.65	15.58	15.77
		1	#Max	15.56	15.57	15.60	15.64	15.48	15.58
		50%	#0	15.41	15.42	15.42	15.50	15.32	15.54
		50%	#Mid	15.46	15.45	15.49	15.52	15.38	15.53
		50%	#Max	15.38	15.42	15.43	15.48	15.33	15.49
		100%	--	15.49	15.41	15.43	15.51	15.40	15.47
	64QAM	1	#0	15.54	15.4	15.52	15.6	15.56	15.62
		1	#Mid	15.59	15.56	15.56	15.52	15.56	15.58
		1	#Max	15.52	15.48	15.44	15.39	15.4	15.28
		50%	#0	15.42	15.33	15.46	15.36	15.42	15.42
		50%	#Mid	15.45	15.38	15.41	15.41	15.4	15.34
		50%	#Max	15.44	15.34	15.41	15.32	15.37	15.29
		100%	--	15.27	15.32	15.34	15.37	15.35	15.3
Mid	QPSK	1	#0	15.61	15.57	15.71	15.80	15.66	15.89
		1	#Mid	15.70	15.70	15.72	15.72	15.72	15.88
		1	#Max	15.63	15.55	15.63	15.64	15.65	15.84
		50%	#0	15.66	15.60	15.74	15.76	15.74	15.75
		50%	#Mid	15.67	15.64	15.75	15.77	15.77	15.56
		50%	#Max	15.68	15.62	15.72	15.68	15.72	15.52
		100%	--	15.69	15.61	15.71	15.72	15.72	15.57
	16QAM	1	#0	15.62	15.68	15.70	15.68	15.65	15.67
		1	#Mid	15.72	15.67	15.67	15.73	15.76	15.58
		1	#Max	15.63	15.66	15.64	15.80	15.70	15.58

		50%	#0	15.48	15.55	15.66	15.76	15.49	15.42	
		50%	#Mid	15.60	15.59	15.65	15.73	15.54	15.41	
		50%	#Max	15.53	15.52	15.63	15.67	15.50	15.37	
		100%	--	15.54	15.55	15.62	15.72	15.55	15.34	
	64QAM	1	#0	15.34	15.14	15.23	15.29	15.29	15.4	
		1	#Mid	15.45	15.2	15.19	15.18	15.16	15.33	
		1	#Max	15.33	15.06	15.1	15.05	15.03	15	
		50%	#0	15.27	15.01	15.12	15.06	15.13	15.17	
		50%	#Mid	15.35	15	15.08	15.04	15.13	15.07	
		50%	#Max	15.29	15.08	15.02	14.94	15.03	14.9	
	100%	--	15.07	15.05	15	15.02	15.02	15		
	High	QPSK	1	#0	15.48	15.54	15.63	15.62	15.55	15.73
			1	#Mid	15.57	15.62	15.62	15.49	15.63	15.70
1			#Max	15.54	15.47	15.55	15.44	15.55	15.58	
50%			#0	15.54	15.55	15.68	15.55	15.61	15.72	
50%			#Mid	15.59	15.57	15.68	15.60	15.64	15.63	
50%			#Max	15.56	15.52	15.64	15.49	15.63	15.70	
100%			--	15.56	15.55	15.64	15.52	15.58	15.63	
16QAM		1	#0	15.69	15.71	15.59	15.70	15.61	15.67	
		1	#Mid	15.65	15.67	15.60	15.67	15.61	15.62	
		1	#Max	15.64	15.71	15.63	15.57	15.51	15.48	
		50%	#0	15.42	15.66	15.49	15.54	15.38	15.39	
		50%	#Mid	15.46	15.69	15.53	15.51	15.39	15.31	
		50%	#Max	15.41	15.66	15.45	15.43	15.35	15.41	
		100%	--	15.50	15.62	15.46	15.48	15.45	15.32	
64QAM		1	#0	15.38	15.01	15.01	15.08	15.15	15.05	
		1	#Mid	15.35	15.12	15.09	15.11	15.07	15.03	
		1	#Max	15.1	15.02	15.09	15.01	5.09	15.08	
		50%	#0	15.17	15.01	15.02	15.02	15.06	15.07	
		50%	#Mid	15.24	15.01	15.09	15.03	15.02	15.03	
		50%	#Max	15.2	15.06	15.03	15.04	15.09	15.05	
		100%	--	15.12	15.03	15.08	15.05	15.04	15.05	

P-Sensor Off

Channel	Modulation	LTE Band 71							
		RB	RB	Maximum Conducted Output Power					
		No.	Offset	1.4M	3M	5M	10M	15M	20M
Low	QPSK	1	#0	--	--	23.74	23.75	23.71	23.87
		1	#Mid	--	--	23.77	23.75	23.73	23.79
		1	#Max	--	--	23.73	23.79	23.75	23.83
		50%	#0	--	--	22.76	22.79	22.78	22.77
		50%	#Mid	--	--	22.74	22.84	22.88	22.79
		50%	#Max	--	--	22.73	22.86	22.81	22.75
		100%	--	--	--	22.88	22.80	22.88	23.03
	16QAM	1	#0	--	--	22.28	22.21	22.87	23.03
		1	#Mid	--	--	22.99	22.17	22.85	23.13
		1	#Max	--	--	22.23	22.27	22.29	22.94
		50%	#0	--	--	21.93	21.97	21.82	22.07
		50%	#Mid	--	--	21.96	21.92	21.97	22.14
		50%	#Max	--	--	21.88	21.97	21.86	22.05
		100%	--	--	--	21.86	21.91	22.00	22.08
	64QAM	1	#0	--	--	23.25	22.79	22.6	22.79
		1	#Mid	--	--	22.91	22.89	22.83	22.7
		1	#Max	--	--	22.93	23.21	22.7	23.15
		50%	#0	--	--	21.94	21.93	21.86	21.84
		50%	#Mid	--	--	22.01	21.88	21.92	21.82
		50%	#Max	--	--	21.95	21.88	21.82	21.83
		100%	--	--	--	21.96	21.86	21.96	21.85
Mid	QPSK	1	#0	--	--	23.61	23.64	23.73	23.93
		1	#Mid	--	--	23.71	23.54	23.68	23.68
		1	#Max	--	--	23.63	23.70	23.59	23.80
		50%	#0	--	--	22.72	22.71	22.71	22.85
		50%	#Mid	--	--	22.71	22.75	22.76	22.83
		50%	#Max	--	--	22.73	22.67	22.69	22.87
		100%	--	--	--	22.72	22.71	22.72	22.85
	16QAM	1	#0	--	--	22.88	22.91	22.21	22.93
		1	#Mid	--	--	22.87	22.65	22.26	22.84
		1	#Max	--	--	22.20	22.58	22.09	22.88

		50%	#0	--	--	21.79	21.81	21.79	21.96	
		50%	#Mid	--	--	21.78	21.86	21.79	21.98	
		50%	#Max	--	--	21.72	21.81	21.73	21.92	
		100%	--	--	--	21.83	21.82	21.68	21.88	
	64QAM	1	#0	--	--	22.65	23.03	23.19	23.29	
		1	#Mid	--	--	22.69	23.12	22.93	23.1	
		1	#Max	--	--	22.81	22.92	22.77	23.09	
		50%	#0	--	--	21.79	21.86	21.84	21.77	
		50%	#Mid	--	--	21.85	21.91	21.8	21.78	
		50%	#Max	--	--	21.8	21.8	21.73	21.69	
		100%	--	--	--	21.77	21.89	21.69	21.79	
	High	QPSK	1	#0	--	--	23.54	23.62	23.57	23.87
			1	#Mid	--	--	23.51	23.49	23.55	23.72
1			#Max	--	--	23.48	23.46	23.44	23.66	
50%			#0	--	--	22.53	22.58	22.61	22.78	
50%			#Mid	--	--	22.53	22.58	22.62	22.85	
50%			#Max	--	--	22.47	22.60	22.55	22.74	
100%			--	--	--	22.55	22.59	22.60	22.79	
16QAM		1	#0	--	--	22.60	22.97	22.75	23.15	
		1	#Mid	--	--	22.49	22.97	22.73	23.08	
		1	#Max	--	--	22.69	22.78	22.95	22.97	
		50%	#0	--	--	21.58	21.56	21.60	21.86	
		50%	#Mid	--	--	21.47	21.65	21.71	21.93	
		50%	#Max	--	--	21.44	21.66	21.57	21.79	
		100%	--	--	--	21.56	21.65	21.68	21.85	
64QAM		1	#0	--	--	22.71	22.79	22.74	22.69	
		1	#Mid	--	--	22.64	22.6	22.74	22.56	
		1	#Max	--	--	22.85	22.57	22.65	22.61	
		50%	#0	--	--	21.64	21.63	21.61	21.7	
		50%	#Mid	--	--	21.62	21.78	21.61	21.7	
		50%	#Max	--	--	21.66	21.67	21.61	21.62	
		100%	--	--	--	21.59	21.73	21.63	21.66	

P-Sensor On

Channel	Modulation	LTE Band 71							
		RB	RB	Maximum Conducted Output Power					
		No.	Offset	1.4M	3M	5M	10M	15M	20M
Low	QPSK	1	#0	--	--	19.18	19.07	19.13	19.15
		1	#Mid	--	--	19.16	19.02	19.06	19.21
		1	#Max	--	--	19.14	19.11	19.08	19.14
		50%	#0	--	--	19.27	19.18	19.07	19.24
		50%	#Mid	--	--	19.29	19.01	19.04	19.36
		50%	#Max	--	--	19.22	19.04	19.01	19.11
		100%	--	--	--	19.25	19.26	19.18	19.33
	16QAM	1	#0	--	--	19.46	19.41	19.17	19.40
		1	#Mid	--	--	19.47	19.04	19.20	19.27
		1	#Max	--	--	19.40	19.33	19.21	19.10
		50%	#0	--	--	19.39	19.20	19.11	19.43
		50%	#Mid	--	--	19.38	19.21	19.02	19.47
		50%	#Max	--	--	19.31	19.09	19.04	19.35
		100%	--	--	--	19.33	19.31	19.31	19.40
	64QAM	1	#0	--	--	19.34	19.1	19.5	19.32
		1	#Mid	--	--	19.28	19.12	19.04	19.84
		1	#Max	--	--	19.23	19.2	19.13	19.7
		50%	#0	--	--	19.21	19.21	19.16	19.33
		50%	#Mid	--	--	19.19	19.22	19.26	19.45
		50%	#Max	--	--	19.16	19.18	19.23	19.27
		100%	--	--	--	19.17	19.34	19.4	19.5
Mid	QPSK	1	#0	--	--	19.10	19.05	19.29	19.44
		1	#Mid	--	--	19.08	19.03	19.01	19.49
		1	#Max	--	--	19.04	18.95	19.22	19.27
		50%	#0	--	--	19.21	19.07	19.10	19.36
		50%	#Mid	--	--	19.24	19.04	19.23	19.42
		50%	#Max	--	--	19.14	19.04	19.19	19.20
		100%	--	--	--	19.22	19.22	19.38	19.48
	16QAM	1	#0	--	--	19.49	19.45	19.59	19.54
		1	#Mid	--	--	19.41	19.57	19.57	19.60
		1	#Max	--	--	19.38	19.10	19.66	19.34

		50%	#0	--	--	19.26	19.10	19.22	19.44	
		50%	#Mid	--	--	19.27	19.08	19.32	19.61	
		50%	#Max	--	--	19.20	19.10	19.22	19.35	
		100%	--	--	--	19.18	19.21	19.48	19.53	
	64QAM	1	#0	--	--	19.35	19.08	19.35	19.41	
		1	#Mid	--	--	19.36	19.04	19.46	19.08	
		1	#Max	--	--	19.29	19.02	19.11	19.19	
		50%	#0	--	--	19.21	19.12	19.07	19.14	
		50%	#Mid	--	--	19.24	19.07	19.1	19.29	
		50%	#Max	--	--	19.27	19.04	19.05	19.05	
	100%	--	--	--	19.22	19.26	19.21	19.35		
	High	QPSK	1	#0	--	--	19.06	19.08	19.01	19.07
			1	#Mid	--	--	19.01	19.05	19.07	19.27
1			#Max	--	--	19.07	19.09	19.07	19.12	
50%			#0	--	--	19.08	19.10	19.09	19.14	
50%			#Mid	--	--	19.01	19.02	19.02	19.15	
50%			#Max	--	--	19.06	19.20	19.06	19.03	
100%			--	--	--	19.03	19.21	19.03	19.22	
16QAM		1	#0	--	--	19.06	19.07	19.22	19.35	
		1	#Mid	--	--	19.05	19.02	19.26	19.16	
		1	#Max	--	--	19.08	19.10	19.02	19.06	
		50%	#0	--	--	19.01	19.07	19.11	19.16	
		50%	#Mid	--	--	19.02	19.03	19.01	19.18	
		50%	#Max	--	--	19.04	19.01	19.03	19.02	
		100%	--	--	--	19.03	19.23	19.00	19.20	
64QAM		1	#0	--	--	19.09	19.23	19.33	19.15	
		1	#Mid	--	--	19.08	19.03	19.14	19.03	
		1	#Max	--	--	19.01	19.07	19.06	19.13	
		50%	#0	--	--	19.03	19.04	19.07	19.08	
		50%	#Mid	--	--	19.05	19.05	19.04	19.12	
		50%	#Max	--	--	19.02	19.09	19.07	19.17	
		100%	--	--	--	19.04	19.03	19.05	19.17	

LTE Intra-Band Up-Link Carrier Aggregation

Number	Combination
1	7C
2	38C
3	41C

P-Sensor Off

2UL_CA_7C Maximum Average Output Power											
Channel	PCC					SCC					Total Power (dBm)
	BW (MHz)	Channel	Frquency (MHz)	RB No.	RB offest	BW (MHz)	Channel	Frquency (MHz)	RB No.	RB offest	QPSK
Low	20	20850	2510	1	99	20	21048	2529.8	1	0	23.76
Mid	20	21001	2525.1	1	99	20	21199	2544.9	1	0	23.55
High	20	21350	2540.2	1	99	20	21350	2560	1	0	23.66

2UL_CA_38C Maximum Average Output Power											
Channel	PCC					SCC					Total Power (dBm)
	BW (MHz)	Channel	Frquency (MHz)	RB No.	RB offest	BW (MHz)	Channel	Frquency (MHz)	RB No.	RB offest	QPSK
Low	20	37850	2580	1	0	10	38048	2599.8	1	0	23.42
Mid	20	37901	2585.1	1	0	20	38099	2604.9	1	0	23.55
High	20	37952	2590.2	1	0	20	38150	2610	1	0	23.50

2UL_CA_41C Maximum Average Output Power											
Channel	PCC					SCC					Total Power (dBm)
	BW (MHz)	Channel	Frquency (MHz)	RB No.	RB offest	BW (MHz)	Channel	Frquency (MHz)	RB No.	RB offest	QPSK
Low	20	39750	2506	1	0	20	39948	2525.8	1	0	23.04
Mid	20	40521	2583.1	1	0	20	40719	2602.9	1	0	23.05
High	20	41292	2660.2	1	0	20	41490	2680	1	0	23.01

P-Sensor On

2UL_CA_7C Maximum Average Output Power											
Channel	PCC					SCC					Total Power (dBm)
	BW (MHz)	Channel	Frquency (MHz)	RB No.	RB offest	BW (MHz)	Channel	Frquency (MHz)	RB No.	RB offest	QPSK
Low	20	20850	2510	1	0	20	21048	2529.8	1	0	16.82
Mid	20	21001	2525.1	1	0	20	21199	2544.9	1	0	17.00
High	20	21350	2540.2	1	0	20	21350	2560	1	0	16.71

2UL_CA_38C Maximum Average Output Power											
Channel	PCC					SCC					Total Power (dBm)
	BW (MHz)	Channel	Frquency (MHz)	RB No.	RB offest	BW (MHz)	Channel	Frquency (MHz)	RB No.	RB offest	QPSK
Low	20	37850	2580	1	0	10	38048	2599.8	1	0	18.62
Mid	20	37901	2585.1	1	0	20	38099	2604.9	1	0	18.69
High	20	37952	2590.2	1	0	20	38150	2610	1	0	18.54

2UL_CA_41C Maximum Average Output Power											
Channel	PCC					SCC					Total Power (dBm)
	BW (MHz)	Channel	Frquency (MHz)	RB No.	RB offest	BW (MHz)	Channel	Frquency (MHz)	RB No.	RB offest	QPSK
Low	20	39750	2506	1	99	20	39948	2525.8	1	0	18.05
Mid	20	40521	2583.1	1	99	20	40719	2602.9	1	0	18.52
High	20	41292	2660.2	1	99	20	41490	2680	1	0	17.96

LTE Down-Link Carrier Aggregation

The tables show the supported frequency bands of the device for DL Inter-band and DL Intra-band combinations.

Index	2CC	Restriction	Completely Covered by Measurement Superset	Index	3CC	Restriction	Completely Covered by Measurement Superset
2CC #1	CA_2A-13A		3CC #2	3CC #1	CA_2A-12A-66A		No
2CC #2	CA_2A-14A		3CC #3	3CC #2	CA_2A-13A-66A		No
2CC #3	CA_2A-66A		3CC #19	3CC #3	CA_2A-14A-66A		No
2CC #4	CA_2A-71A		3CC #12	3CC #4	CA_2A-29A-66A		No
2CC #5	CA_2C		3CC #23	3CC #5	CA_2A-2A-12A		No
2CC #6	CA_30A-66A		3CC #52	3CC #6	CA_2A-2A-13A		No
2CC #7	CA_38C		No	3CC #7	CA_2A-2A-14A		No
2CC #8	CA_41A-41A		No	3CC #8	CA_2A-2A-29A		No
2CC #9	CA_41C		3CC #53	3CC #9	CA_2A-2A-4A		No
2CC #10	CA_4A-13A		3CC #25	3CC #10	CA_2A-2A-5A		No
2CC #11	CA_4A-30A		3CC #24	3CC #11	CA_2A-2A-66A		No
2CC #12	CA_4A-5A		3CC #26	3CC #12	CA_2A-2A-71A		No
2CC #13	CA_4A-71A		3CC #27	3CC #13	CA_2A-4A-13A		No
2CC #14	CA_4A-7A		3CC #30	3CC #14	CA_2A-4A-4A		No
2CC #15	CA_5A-30A		3CC #31	3CC #15	CA_2A-4A-5A		No
2CC #16	CA_5A-41A		No	3CC #16	CA_2A-4A-71A		No
2CC #17	CA_5A-5A		3CC #32	3CC #17	CA_2A-5A-66A		No
2CC #18	CA_5A-66A		3CC #33	3CC #18	CA_2A-5B		No
2CC #19	CA_5A-7A		No	3CC #19	CA_2A-66A-66A		No
2CC #20	CA_5B		3CC #37	3CC #20	CA_2A-66A-71A		No
2CC #21	CA_7C		No	3CC #21	CA_2A-66B		3CC #22
2CC #22	CA_66A-66A		3CC #54	3CC #22	CA_2A-66C		No
2CC #23	CA_66A-71A		3CC #57	3CC #23	CA_2C-66A		No
2CC #24	CA_66B		3CC #58	3CC #24	CA_4A-12A-30A		No
2CC #25	CA_12A-30A		3CC #40	3CC #25	CA_4A-4A-13A		No
2CC #26	CA_13A-66A		3CC #41	3CC #26	CA_4A-4A-5A		No
2CC #27	CA_14A-30A		3CC #45	3CC #27	CA_4A-4A-71A		No
2CC #28	CA_14A-66A		3CC #46	3CC #28	CA_4A-5A-30A		No

2CC #29	CA_25A-25A		3CC #47	3CC #29	CA_4A-5B		No
2CC #30	CA_25A-26A		3CC #47	3CC #30	CA_4A-7C		No
2CC #31	CA_26A-41A		3CC #49	3CC #31	CA_5A-30A-66A		No
2CC #32	CA_29A-30A	B29 SCC Only	3CC #50	3CC #32	CA_5A-5A-66A		No
2CC #33	CA_29A-66A	B29 SCC Only	3CC #51	3CC #33	CA_5A-66A-66A		No
				3CC #34	CA_5A-66B		3CC #35
				3CC #35	CA_5A-66C		No
				3CC #36	CA_5A-7C		No
				3CC #37	CA_5B-30A		No
				3CC #38	CA_5B-66A		No
				3CC #39	CA_7A-66A-66A		No
				3CC #40	CA_12A-30A-66A		No
				3CC #41	CA_12A-66C		No
				3CC #42	CA_13A-66A-66A		No
				3CC #43	CA_13A-66B		3CC #44
				3CC #44	CA_13A-66C		No
				3CC #45	CA_14A-30A-66A		No
				3CC #46	CA_14A-66A-66A		No
				3CC #47	CA_25A-25A-26A		No
				3CC #48	CA_25A-46C		No
				3CC #49	CA_26A-41C		No
				3CC #50	CA_29A-30A-66A	B29 SCC Only	No
				3CC #51	CA_29A-66A-66A	B29 SCC Only	No
				3CC #52	CA_30A-66A-66A		No
				3CC #53	CA_41D		No
				3CC #54	CA_66A-66A-71A		No
				3CC #55	CA_66A-66B		3CC #56
				3CC #56	CA_66A-66C		No
				3CC #57	CA_66C-71A		No
				3CC #58	CA_66D		No

Two Component Carrier Maximum Conducted Power													
PCC							SCC				TX Power (dBm)		Configurations
Band	BW (MHz)	Modulation	RB No.	RB offset	Channel	Frquency (MHz)	Band	BW (MHz)	Channel	Frquency (MHz)	CA Active	CA Inactive	
LTE B38	20	QPSK	1	0	37901	2585.1	LTE B38	20	38099	2604.9	23.61	23.98	CA_38C
LTE B41	20	QPSK	1	0	39750	2506	LTE B41	20	41490	2680	24.04	24.22	CA_41A-41A
LTE B5	10	QPSK	1	49	20525	836.5	LTE B41	20	41490	2680	24.06	24.22	CA_5A-41A
LTE B5	10	QPSK	1	49	20525	836.5	LTE B7	20	3100	2655	24.16	24.22	CA_5A-7A
LTE B7	20	QPSK	1	99	21001	2525.1	LTE B7	20	3199	2664.9	24.55	24.61	CA_7C

Three Component Carrier Maximum Conducted Power																	
PCC							SCC				SCC				TX Power (dBm)		Configurations
Band	BW (MHz)	Modulation	RB No.	RB offset	Channel	Frquency (MHz)	Band	BW (MHz)	Channel	Frquency (MHz)	Band	BW (MHz)	Channel	Frquency (MHz)	CA Active	CA Inactive	
LTE B2	20	QPSK	1	0	18900	1880	LTE B12	10	5155	743.5	LTE B66	20	66786	2145	24.41	24.47	CA_2A-12A-66A
LTE B2	20	QPSK	1	0	18900	1880	LTE B13	10	5230	751	LTE B66	20	66786	2145	24.44	24.47	CA_2A-13A-66A
LTE B2	20	QPSK	1	0	18900	1880	LTE B14	10	5330	763	LTE B66	20	66786	2145	24.38	24.47	CA_2A-14A-66A
LTE B2	20	QPSK	1	0	18900	1880	LTE B29	10	9715	722.5	LTE B66	20	66786	2145	24.41	24.47	CA_2A-29A-66A
LTE B2	20	QPSK	1	0	18700	1860	LTE B2	20	1100	1980	LTE B12	10	5155	743.5	24.23	24.28	CA_2A-2A-12A
LTE B2	20	QPSK	1	0	18700	1860	LTE B2	20	1100	1980	LTE B13	10	5230	751	24.22	24.28	CA_2A-2A-13A
LTE B2	20	QPSK	1	0	18700	1860	LTE B2	20	1100	1980	LTE B14	10	5330	763	24.23	24.28	CA_2A-2A-14A
LTE B2	20	QPSK	1	0	18700	1860	LTE B2	20	1100	1980	LTE B29	10	9715	722.5	24.23	24.28	CA_2A-2A-29A
LTE B2	20	QPSK	1	0	18700	1860	LTE B2	20	1100	1980	LTE B4	20	2175	2132.5	24.25	24.28	CA_2A-2A-4A
LTE B2	20	QPSK	1	0	18700	1860	LTE B2	20	1100	1980	LTE B5	10	2525	881.5	24.24	24.28	CA_2A-2A-5A
LTE B2	20	QPSK	1	0	18700	1860	LTE B2	20	1100	1980	LTE B66	20	66786	2145	24.23	24.28	CA_2A-2A-66A
LTE B2	20	QPSK	1	0	18700	1860	LTE B2	20	1100	1980	LTE B71	20	68786	637	24.25	24.28	CA_2A-2A-71A
LTE B2	20	QPSK	1	0	18900	1880	LTE B4	20	2175	2132.5	LTE B13	10	5230	751	24.45	24.47	CA_2A-4A-13A
LTE B2	20	QPSK	1	0	18900	1880	LTE B4	20	2300	2145	LTE B4	20	2300	2145	24.40	24.47	CA_2A-4A-4A
LTE B2	20	QPSK	1	0	18900	1880	LTE B4	20	2175	2132.5	LTE B5	10	2575	886.5	24.46	24.47	CA_2A-4A-5A
LTE B2	20	QPSK	1	0	18900	1880	LTE B4	20	2175	2132.5	LTE B71	20	68786	637	24.44	24.47	CA_2A-4A-71A
LTE B2	20	QPSK	1	0	18900	1880	LTE B5	10	2575	886.5	LTE B66	20	66786	2145	24.42	24.47	CA_2A-5A-66A
LTE B2	20	QPSK	1	0	18900	1880	LTE B5	10	2476	876.6	LTE B5	10	2575	886.5	24.43	24.47	CA_2A-5B
LTE B2	20	QPSK	1	0	18900	1880	LTE B66	20	66985	2164.9	LTE B66	20	66985	2164.9	24.44	24.47	CA_2A-66A-66A
LTE B2	20	QPSK	1	0	18900	1880	LTE B66	20	66786	2145	LTE B71	20	68786	637	24.45	24.47	CA_2A-66A-71A

LTE B2	20	QPSK	1	0	18900	1880	LTE B66	20	67038	2170.2	LTE B66	20	67236	2190	24.45	24.47	CA_2A-66C
LTE B2	20	QPSK	1	0	18900	1880	LTE B66	20	66786	2145	LTE B66	20	66786	2145	24.45	24.47	CA_2C-66A
LTE B4	20	QPSK	1	0	20175	1732.5	LTE B12	10	5155	743.5	LTE B30	10	9820	2355	24.33	24.45	CA_4A-12A-30A
LTE B4	20	QPSK	1	0	20175	1732.5	LTE B4	20	2300	2145	LTE B13	10	5230	751	24.29	24.45	CA_4A-4A-13A
LTE B4	20	QPSK	1	0	20175	1732.5	LTE B4	20	2300	2145	LTE B5	10	2525	881.5	24.28	24.45	CA_4A-4A-5A
LTE B4	20	QPSK	1	0	20175	1732.5	LTE B4	20	2300	2145	LTE B71	20	68786	637	24.27	24.45	CA_4A-4A-71A
LTE B4	20	QPSK	1	0	20175	1732.5	LTE B5	10	2575	886.5	LTE B30	10	9820	2355	24.26	24.45	CA_4A-5A-30A
LTE B4	20	QPSK	1	0	20175	1732.5	LTE B5	10	2476	876.6	LTE B5	10	2575	886.5	24.25	24.45	CA_4A-5B
LTE B4	20	QPSK	1	0	20175	1732.5	LTE B7	20	3001	2645.1	LTE B7	20	3199	2664.9	24.25	24.45	CA_4A-7C
LTE B5	10	QPSK	1	0	20525	836.5	LTE B30	10	9820	2355	LTE B66	20	66786	2145	23.78	23.81	CA_5A-30A-66A
LTE B5	20	QPSK	1	0	20525	836.5	LTE B5	10	2575	886.5	LTE B66	20	66786	2145	23.77	23.81	CA_5A-5A-66A
LTE B5	20	QPSK	1	0	20525	836.5	LTE B66	20	66786	2145	LTE B66	20	66786	2145	23.71	23.81	CA_5A-66A-66A
LTE B5	20	QPSK	1	0	20525	836.5	LTE B66	20	67038	2170.2	LTE B66	20	67236	2190	23.79	23.81	CA_5A-66C
LTE B5	10	QPSK	1	0	20525	836.5	LTE B7	20	3001	2645.1	LTE B7	20	3199	2664.9	23.80	23.81	CA_5A-7C
LTE B5	10	QPSK	1	0	20450	829	LTE B5	10	2476	876.6	LTE B30	10	9820	2355	23.76	23.79	CA_5B-30A
LTE B5	10	QPSK	1	0	20450	829	LTE B5	10	2476	876.6	LTE B66	20	66786	2145	23.77	23.79	CA_5B-66A
LTE B7	20	QPSK	1	0	21100	2535	LTE B66	20	66786	2145	LTE B66	20	66786	2145	24.40	24.42	CA_7A-66A-66A
LTE B12	10	QPSK	1	0	23095	707.5	LTE B30	10	9820	2355	LTE B66	20	66786	2145	23.61	23.63	CA_12A-30A-66A
LTE B12	10	QPSK	1	0	23095	707.5	LTE B66	20	67038	2170.2	LTE B66	20	67236	2190	23.60	23.63	CA_12A-66C
LTE B13	10	QPSK	1	0	23230	782	LTE B66	20	66786	2145	LTE B66	20	66786	2145	24.01	24.25	CA_13A-66A-66A
LTE B13	10	QPSK	1	0	23230	782	LTE B66	20	67038	2170.2	LTE B66	20	67236	2190	24.05	24.25	CA_13A-66C
LTE B14	10	QPSK	1	0	23330	793	LTE B30	10	9820	2355	LTE B66	20	66786	2145	23.92	24.04	CA_14A-30A-66A
LTE B14	10	QPSK	1	0	23330	793	LTE B66	20	66786	2145	LTE B66	20	66786	2145	23.91	24.04	CA_14A-66A-66A
LTE B25	20	QPSK	1	0	26365	1882.5	LTE B25	20	8590	1985	LTE B26	15	8865	876.5	24.31	24.35	CA_25A-25A-26A
LTE B25	20	QPSK	1	0	26365	1882.5	LTE B46	20	50890	5560	LTE B46	20	50890	5560	24.26	24.35	CA_25A-46C
LTE B26	15	QPSK	1	0	26865	831.5	LTE B41	20	40719	2602.9	LTE B41	20	40719	2602.9	23.28	23.84	CA_26A-41C
LTE B30	10	QPSK	1	0	27710	2310	LTE B29	10	9715	722.5	LTE B66	20	66786	2145	22.31	22.34	CA_29A-30A-66A
LTE B66	20	QPSK	1	0	132322	1745	LTE B29	10	9715	722.5	LTE B66	20	66786	2145	23.89	23.99	CA_29A-66A-66A
LTE B30	10	QPSK	1	0	27710	2310	LTE B66	20	66786	2145	LTE B66	20	66786	2145	22.31	22.34	CA_30A-66A-66A
LTE B41	20	QPSK	1	0	40422	2573.2	LTE B41	20	40620	2593	LTE B41	20	40818	2612	24.06	24.22	CA_41D
LTE B66	20	QPSK	1	0	132322	1745	LTE B66	20	66786	2145	LTE B71	20	68786	637	23.73	23.99	CA_66A-66A-71A
LTE B66	20	QPSK	1	0	132072	1720	LTE B66	20	67038	2170.2	LTE B66	20	67236	2190	23.84	23.96	CA_66A-66C
LTE B66	20	QPSK	1	0	132322	1745.1	LTE B66	20	66985	2164.9	LTE B71	20	68786	637	23.83	23.99	CA_66C-71A
LTE B66	20	QPSK	1	0	132224	1735.2	LTE B66	20	66886	2155	LTE B66	20	67084	2174.8	23.87	23.96	CA_66D

9. Proximity Sensor

9.1 proximity sensor triggering distances

According to the KDB 616217 Section 6.2, the following procedures should be applied to determine proximity sensor triggering distances for the back surface and individual edges of a tablet.

- a) The relevant transmitter should be set to operate at its normal maximum output power.
- b) The entire back surface or edge of the tablet is positioned below a flat phantom filled with the required tissue-equivalent medium, and positioned at least 20 mm further than the distance that triggers power reduction.
- c) It should be ensured that the cables required for power measurements are not interfering with the proximity sensor. Cable losses should be properly compensated to report the measured power results.
- d) The back surface or edge is moved toward the phantom in 3 mm steps until the sensor triggers.
- e) The back surface or edge is then moved back (further away) from the phantom by at least 5 mm or until maximum output power is returned to the normal maximum level.
- f) The back surface or edge is again moved toward the phantom, but in 1 mm steps, until it is at least 5 mm past the triggering point or touching the phantom. If 1 mm resolution is not suitable for the sensor triggering sensitivity, a KDB inquiry should be submitted to determine alternative test configurations.
- g) If the tablet is not touching the phantom, it is moved in 3 mm steps until it touches the phantom to confirm that the sensor remains triggered and the maximum power stays reduced.
- h) The process is then reversed by moving the tablet away from the phantom according to steps d) to g), to determine triggering release, until it is at least 10 mm beyond the point that triggers the return of normal maximum power.
- i) The measured output power within 5 mm of the triggering points, or until the tablet is touching the phantom, for movements to and from the phantom should be tabulated in the SAR report.
- j) If the sensor design and implementation allow additional variations for triggering distance tolerances, multiple samples should be tested to determine the most conservative distance required for SAR evaluation.
- k) To ensure all production units are compliant, it is generally necessary to reduce the triggering distance determined from the triggering tests by 1 mm, or more if it is necessary, and use the smallest distance for movements to and from the phantom, minus 1 mm, as the sensor triggering distance for determining the SAR measurement distance.

9.2 Procedures for determining antenna and proximity sensor coverage

Proximity sensors are not normally designed to cover the entire back surface or edges of a tablet. The sensing regions are usually limited to areas near the sensor element. The following are used to determine if additional SAR measurements may be necessary due to sensor and antenna offset.

- a) The back surface or edge of the tablet is positioned at a test separation distance less than or equal to the distance required for back surface or edge triggering, with both the antenna and sensor pad located at least 20 mm laterally outside the edge (boundary) of the phantom, along the direction of maximum antenna and sensor offset. For the back surface, if the direction of maximum offset is not aligned with the tablet coordinates (physical edges) the tablet test position would not be aligned with the phantom coordinates (orientations). Each applicable tablet edge should be positioned perpendicularly to the phantom to determine sensor coverage. For antennas and/or sensors located near the corner of a tablet, both adjacent edges must be considered.
- b) The similar sequence of steps applied to determine sensor triggering distance in 6.2 are used to verify back surface and edge sensor coverage by moving the tablet (sensor and antenna) horizontally toward the phantom while maintaining the same vertical separation between the back surface or edge and the phantom.
- c) After the exact location where triggering of power reduction is determined, with respect to the sensor and antenna, the tablet movement should be continued, in 3 mm increments, until both the sensor and antenna(s) are fully under the phantom and at least 20 mm inside the phantom edge.
- d) The process is then repeated from the opposite direction, starting at the other end of the maximum antenna and sensor offset, by rotating the tablet 180 along the vertical axis.
- e) The triggering points should be documented graphically, with the antenna and sensor clearly identified, along with all relevant dimensions.
- f) If the subsequently measured peak SAR location for the antenna is not between the triggering points, established by the sensor coverage tests from opposite ends of the antenna and sensor, additional SAR tests may be required for conditions where only part of the back surface or edge of a tablet corresponding to the antenna is in proximity to the user and the sensor may not be triggering as desired. A KDB inquiry must be submitted by the test lab to determine if additional tests are required and the proper test configurations to use for testing. This may include situations where the sensor coverage region is too small for the antenna, the sensor is located too far away from the antenna, the sensor location is insufficient to cover multiple antennas or the antenna is at the corner of a tablet etc.

9.3. Summary of Trigger Distance

Mode	Trigger distance - Bottom (cm)	
	Moving toward phantom	Moving from phantom
WWAN	18	18

Note: The smallest separation distance determined in each triggering condition minus 1mm or more should be used in the SAR measurements. A distance of 15mm was used for SAR testing.

Bottom, DUT Moving Toward (Trigger) and Away (Release) from the phantom

Distance to DUT vs. Output Power in dBm										
Distance (cm)	17.6	17.7	17.8	17.9	18	18.1	18.2	18.3	18.4	18.5
WCDMA B2	15.72	15.77	15.73	15.79	15.74	24.61	24.69	24.68	24.60	24.67
WCDMA B5	19.84	19.86	19.82	19.88	19.81	24.50	24.67	24.57	24.55	24.60
LTE Band 2	15.76	15.73	15.72	15.77	15.75	24.38	24.35	24.31	24.32	24.32
LTE Band 4	15.83	15.84	15.82	15.85	15.87	24.69	24.60	24.65	24.69	24.64
LTE Band 5	19.56	19.53	19.52	19.49	19.54	23.93	23.96	24.16	24.10	24.17
LTE Band 7	17.09	17.07	17.05	17.06	17.01	24.00	23.99	24.05	23.99	24.04
LTE Band 12	19.38	19.35	19.31	19.33	19.39	23.90	23.85	23.89	23.90	23.99
LTE Band 13	19.63	19.61	19.67	19.66	19.65	23.86	23.90	23.87	23.87	23.87
LTE Band 14	19.73	19.75	19.77	19.72	19.71	24.06	23.91	23.97	23.91	24.07
LTE Band 17	19.82	19.84	19.81	19.86	19.89	23.53	23.50	23.59	23.57	23.56
LTE Band 25	16.12	16.09	16.14	16.16	16.11	24.15	24.03	24.14	24.13	24.07
LTE Band 26	19.52	19.49	19.54	19.57	19.51	23.85	23.94	23.90	23.85	23.99
LTE Band 30	14.67	14.63	14.77	14.81	14.73	22.87	22.80	22.82	22.82	22.89
LTE Band 38	18.52	18.57	18.55	18.53	18.51	23.61	23.67	23.53	23.55	23.61
LTE Band 41	18.79	18.85	18.80	18.82	18.88	23.99	23.97	24.08	24.02	24.12
LTE Band 66	15.71	15.74	15.80	15.68	15.72	23.91	23.85	23.84	23.94	23.87
LTE Band 71	19.45	19.43	19.46	19.40	19.41	23.98	23.80	23.90	23.89	23.99
LTE Band 41(PC2)	20.54	20.55	20.52	20.53	20.51	26.17	26.15	25.90	25.93	25.94

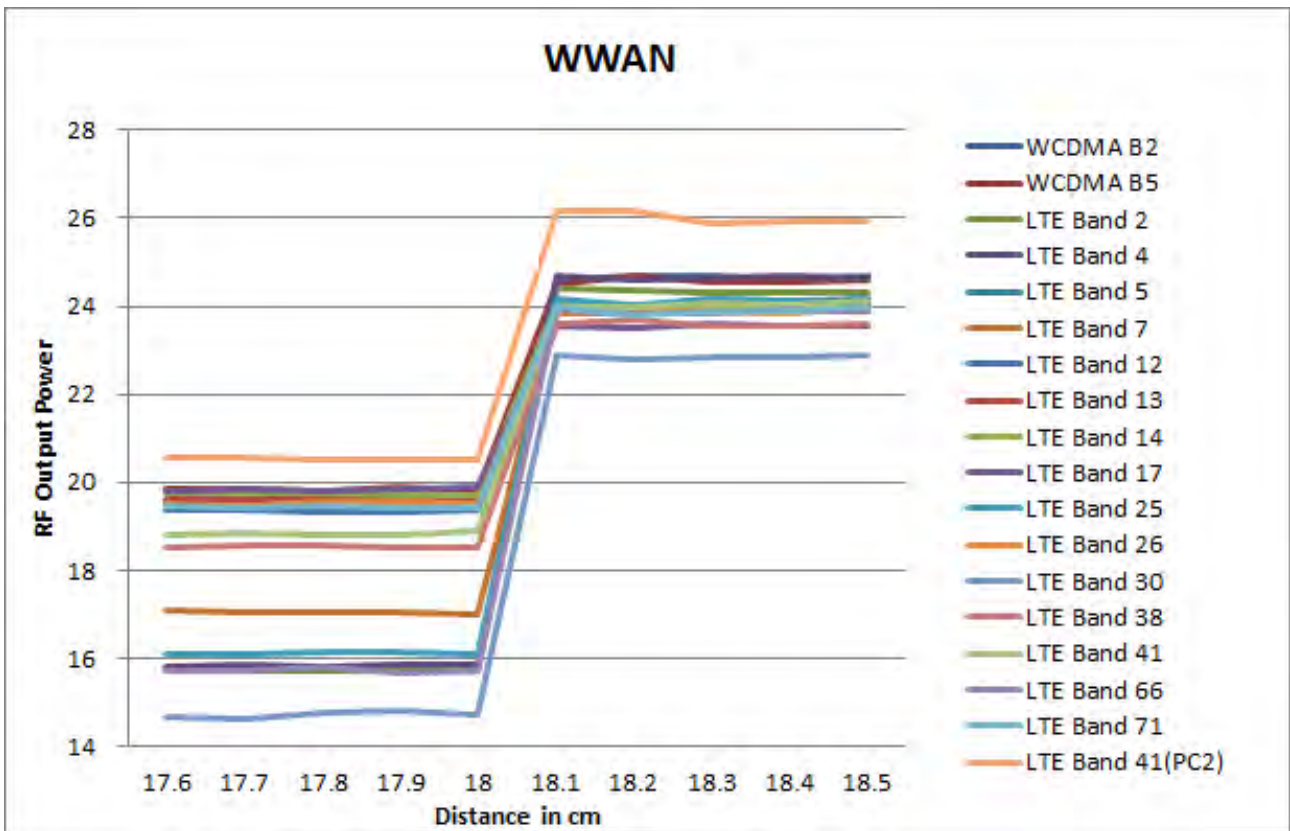

10. Test Results

10.1 SAR Test Results Summary

WLAN 2.4G Body SAR									
SAR MEASUREMENT									
Liquid Temperature (°C) : 21.7 ±2					Relative Humidity (%) : 50				
Ambient Temperature (°C) : 22.4 ±2					Depth of Liquid (cm) : >15				
Test Position	Antenna Position	Dist (mm)	Frequency		Conducted Power (dBm)		SAR 1g (W/kg)		Plot No.
			Channel	MHz	Measurement	Tune-up Limit	Measurement	Tune-up Scaled	
Test Mode: 802.11b_Main(QSIP7180)_ Speed									
Bottom	Fixed	0	6	2437	17.69	19.5	0.005	0.008	
Test Mode: 802.11b_Aux(QSIP7180)_ Speed									
Bottom	Fixed	0	1	2412	17.51	19.5	0.016	0.026	1
Bottom	Fixed	0	6	2437	17.88	19.5	0.007	0.010	
Bottom	Fixed	0	10	2457	17.52	19.5	0.009	0.014	
Test Mode: BT-1M_Aux(QSIP7180)_ Speed									
Bottom	Fixed	0	39	2441	10.3	12	0.010	0.015	2
SAR MEASUREMENT									
Liquid Temperature (°C) : 21.9 ±2					Relative Humidity (%) : 51				
Ambient Temperature (°C) : 22.3 ±2					Depth of Liquid (cm) : >15				
Test Position	Antenna Position	Dist (mm)	Frequency		Conducted Power (dBm)		SAR 1g (W/kg)		Plot No.
			Channel	MHz	Measurement	Tune-up Limit	Measurement	Tune-up Scaled	
Test Mode: 802.11b_Main(QSIP7180)_ WGT									
Bottom	Fixed	0	6	2437	17.69	19.5	0.008	0.013	
Test Mode: 802.11b_Aux(QSIP7180)_ WGT									
Bottom	Fixed	0	1	2412	17.51	19.5	0.016	0.025	
Bottom	Fixed	0	6	2437	17.88	19.5	0.013	0.019	
Bottom	Fixed	0	10	2457	17.52	19.5	0.010	0.015	
Test Mode: BT-1M_Aux(QSIP7180)_ WGT									
Bottom	Fixed	0	39	2441	10.3	12	0.009	0.014	
Note: 1. When the highest reported SAR for DSSS is adjusted by the ratio of OFDM to DSSS specified maximum output power and the adjusted SAR is ≤ 1.2 W/kg, SAR is not required. 2. When the reported SAR of the highest measured maximum output power channel for the exposure configuration is ≤ 0.8 W/kg, no further SAR testing is required for 802.11b DSSS in that exposure configuration.									

WLAN 5G Body SAR									
SAR MEASUREMENT									
Liquid Temperature (°C) : 21.2 ±2					Relative Humidity (%): 49				
Ambient Temperature (°C) : 22.8 ±2					Depth of Liquid (cm):>15				
Test Position	Antenna Position	Dist (mm)	Frequency		Conducted Power (dBm)		SAR 1g (W/kg)		Plot No.
			Channel	MHz	Measurement	Tune-up Limit	Measurement	Tune-up Scaled	
Test Mode: 802.11n40M_Main(QSIP7180) –Speed									
Bottom	Fixed	0	54	5270	17.96	19.5	0.032	0.046	
Bottom	Fixed	0	62	5310	10.81	12.5	0.019	0.027	
Test Mode: 802.11ac80M_Main(QSIP7180) – Speed									
Bottom	Fixed	0	106	5530	12.87	14.5	0.024	0.034	
Bottom	Fixed	0	122	5610	17.71	19.5	0.064	0.097	3
Bottom	Fixed	0	138	5690	17.64	19.5	0.038	0.058	
Bottom	Fixed	0	155	5775	17.91	19.5	0.025	0.036	
Test Mode: 802.11n40M_Aux(QSIP7180) – Speed									
Bottom	Fixed	0	54	5270	17.86	19.5	0.036	0.052	4
Test Mode: 802.11ac80M_Aux(QSIP7180) – Speed									
Bottom	Fixed	0	122	5610	17.89	19.5	0.036	0.052	
Bottom	Fixed	0	155	5775	17.73	19.5	0.048	0.072	5
SAR MEASUREMENT									
Liquid Temperature (°C) : 21.9 ±2					Relative Humidity (%): 51				
Ambient Temperature (°C) : 22.9 ±2					Depth of Liquid (cm):>15				
Test Position	Antenna Position	Dist (mm)	Frequency		Conducted Power (dBm)		SAR 1g (W/kg)		Plot No.
			Channel	MHz	Measurement	Tune-up Limit	Measurement	Tune-up Scaled	
Test Mode: 802.11n40M_Main(QSIP7180) –WGT									
Bottom	Fixed	0	54	5270	17.96	19.5	0.021	0.031	
Bottom	Fixed	0	62	5310	10.81	12.5	0.023	0.033	
Test Mode: 802.11ac80M_Main(QSIP7180) –WGT									
Bottom	Fixed	0	106	5530	12.87	14.5	0.023	0.033	
Bottom	Fixed	0	122	5610	17.71	19.5	0.041	0.062	
Bottom	Fixed	0	138	5690	17.64	19.5	0.020	0.030	
Bottom	Fixed	0	155	5775	17.91	19.5	0.043	0.062	
Test Mode: 802.11n40M_Aux(QSIP7180) –WGT									
Bottom	Fixed	0	54	5270	17.86	19.5	0.024	0.035	

Test Mode: 802.11ac80M_Aux(QSIP7180) –WGT									
Bottom	Fixed	0	122	5610	17.89	19.5	0.040	0.057	
Bottom	Fixed	0	155	5775	17.73	19.5	0.041	0.061	
<p>Note : 1. When multiple transmission modes have the same specified maximum output power, largest channel bandwidth, lowest order modulation and lowest data rate, the lowest order 802.11 mode is selected</p> <p>2. When the reported SAR of the highest measured maximum output power channel for the exposure configuration is ≤ 0.8 W/kg, no further SAR testing is required in that exposure configuration.</p> <p>3. When the reported SAR of the highest measured maximum U-NII-2A for the exposure configuration is ≤ 1.2 W/kg, SAR is not required for U-NII-1 band.</p>									

WCDMA B2 Body SAR									
SAR MEASUREMENT									
Liquid Temperature (°C) : 22.4 ±2					Relative Humidity (%): 51				
Ambient Temperature (°C) : 23.1 ±2					Depth of Liquid (cm):>15				
Test Position	Antenna Position	Dist (mm)	Frequency		Conducted Power (dBm)		SAR 1g (W/kg)		Plot No.
			Channel	MHz	Measurement	Tune-up Limit	Measurement	Tune-up Scaled	
Test Mode: WCDMA Band 2 RMC Speed_0mm									
Bottom	Fixed	0	9262	1852.4	15.92	17.5	0.607	0.873	
Bottom	Fixed	0	9400	1880	16.01	17.5	0.578	0.815	
Bottom	Fixed	0	9538	1907.6	15.71	17.5	0.616	0.930	6
Test Mode: WCDMA Band 2 RMC Speed_15mm									
Bottom	Fixed	15	9262	1852.4	24.25	25.7	0.589	0.822	
Bottom	Fixed	15	9400	1880	24.6	25.7	0.569	0.733	
Bottom	Fixed	15	9538	1907.6	24.51	25.7	0.505	0.664	
Note: 1. When the reported SAR of the Mid channel for the exposure configuration is ≤ 0.8 W/kg, no further SAR testing is required in other channel.									

WCDMA B5 Body SAR									
SAR MEASUREMENT									
Liquid Temperature (°C) : 22.1 ±2					Relative Humidity (%): 52				
Ambient Temperature (°C) : 23.2 ±2					Depth of Liquid (cm):>15				
Test Position	Antenna Position	Dist (mm)	Frequency		Conducted Power (dBm)		SAR 1g (W/kg)		Plot No.
			Channel	MHz	Measurement	Tune-up Limit	Measurement	Tune-up Scaled	
Test Mode: WCDMA Band 5 RMC Speed_0mm									
Bottom	Fixed	0	4132	826.4	19.81	21.5	0.685	1.011	7
Bottom	Fixed	0	4183	836.6	19.92	21.5	0.652	0.938	
Bottom	Fixed	0	4233	846.6	19.84	21.5	0.649	0.951	
Test Mode: WCDMA Band 5 RMC Speed_15mm									
Bottom	Fixed	15	4132	826.4	24.37	25.2	0.425	0.515	
Bottom	Fixed	15	4183	836.6	24.46	25.2	0.416	0.493	
Bottom	Fixed	15	4233	846.6	24.34	25.2	0.434	0.529	
Note: 1. When the reported SAR of the Mid channel for the exposure configuration is ≤ 0.8 W/kg, no further SAR testing is required in other channel.									

LTE Band 2 Body SAR											
SAR MEASUREMENT											
Liquid Temperature (°C): 22.4 ±2							Relative Humidity (%): 51				
Ambient Temperature (°C): 23.1 ±2							Depth of Liquid (cm): >15				
Test Position	Antenna Position	Dist (mm)	RB	RB offset	Frequency		Conducted Power (dBm)		SAR 1g (W/Kg)		Plot No.
					Channel	MHz	Measurement	Tune-up Limit	Measurement	Tune-up Scaled	
Test Mode: LTE Band 2 QPSK 20M Speed_0mm											
Bottom	Fixed	0	1	0	18700	1860	15.97	17.5	0.573	0.815	8
Bottom	Fixed	0	1	0	18900	1880	16.18	17.5	0.525	0.711	
Bottom	Fixed	0	1	0	19100	1900	15.95	17.5	0.512	0.732	
Bottom	Fixed	0	50	0	18700	1860	15.94	17.5	0.555	0.795	
Bottom	Fixed	0	100	0	18700	1860	15.95	17.5	0.569	0.813	
Bottom	Fixed	0	100	0	18900	1880	15.89	17.5	0.550	0.797	
Bottom	Fixed	0	100	0	19100	1900	15.9	17.5	0.548	0.792	
Test Mode: LTE Band 2 QPSK 20M Speed_15mm											
Bottom	Fixed	15	1	0	18700	1860	24.38	25.7	0.497	0.674	
Bottom	Fixed	15	1	0	18900	1880	24.47	25.7	0.517	0.686	
Bottom	Fixed	15	1	0	19100	1900	24.36	25.7	0.479	0.652	
Bottom	Fixed	15	50	0	18900	1880	23.55	24.7	0.426	0.555	
Note: 1. When the reported SAR of the Mid channel for the exposure configuration is ≤ 0.8 W/kg, no further SAR testing is required in other channel.											

LTE Band 4 Body SAR											
SAR MEASUREMENT											
Liquid Temperature (°C): 22.4 ±2						Relative Humidity (%): 51					
Ambient Temperature (°C): 23.1 ±2						Depth of Liquid (cm): >15					
Test Position	Antenna Position	Dist (mm)	RB	RB offset	Frequency		Conducted Power (dBm)		SAR 1g (W/Kg)		Plot No.
					Channel	MHz	Measurement	Tune-up Limit	Measurement	Tune-up Scaled	
Test Mode: LTE Band 4 QPSK 20M Speed_0mm											
Bottom	Fixed	0	1	0	20050	1720	15.91	17	0.547	0.703	
Bottom	Fixed	0	1	0	20175	1732.5	15.98	17	0.569	0.720	
Bottom	Fixed	0	1	0	20300	1745	15.79	17	0.580	0.766	9
Bottom	Fixed	0	50	25	20300	1745	15.91	17	0.569	0.731	
Test Mode: LTE Band 4 QPSK 20M Speed_15mm											
Bottom	Fixed	15	1	0	20050	1720	24.4	25.7	0.506	0.683	
Bottom	Fixed	15	1	0	20175	1732.5	24.45	25.7	0.552	0.736	
Bottom	Fixed	15	1	0	20300	1745	24.36	25.7	0.543	0.739	
Bottom	Fixed	15	50	25	20175	1732.5	23.45	24.7	0.455	0.607	
Note: 1. When the reported SAR of the Mid channel for the exposure configuration is ≤ 0.8 W/kg, no further SAR testing is required in other channel.											

LTE Band 5 Body SAR											
SAR MEASUREMENT											
Liquid Temperature (°C): 22.1 ±2						Relative Humidity (%): 52					
Ambient Temperature (°C): 23.2 ±2						Depth of Liquid (cm): >15					
Test Position	Antenna Position	Dist (mm)	RB	RB offset	Frequency		Conducted Power (dBm)		SAR 1g (W/Kg)		Plot No.
					Channel	MHz	Measurement	Tune-up Limit	Measurement	Tune-up Scaled	
Test Mode: LTE Band 5 QPSK 10M Speed_0mm											
Bottom	Fixed	0	1	0	20450	829	19.7	21	0.618	0.834	
Bottom	Fixed	0	1	0	20525	836.5	19.85	21	0.601	0.783	
Bottom	Fixed	0	1	0	20600	844	19.8	21	0.445	0.587	
Bottom	Fixed	0	25	12	20450	829	19.64	21	0.616	0.843	10
Bottom	Fixed	0	25	12	20525	836.5	19.7	21	0.592	0.799	
Bottom	Fixed	0	25	12	20600	844	19.77	21	0.594	0.788	
Bottom	Fixed	0	50	0	20450	829	19.64	21	0.609	0.833	
Bottom	Fixed	0	50	0	20525	836.5	19.58	21	0.589	0.817	
Bottom	Fixed	0	50	0	20600	844	19.63	21	0.595	0.816	
Test Mode: LTE Band 5 QPSK 10M Speed_15mm											
Bottom	Fixed	15	1	49	20450	829	24.01	25.2	0.353	0.464	
Bottom	Fixed	15	1	49	20525	836.5	24.22	25.2	0.351	0.44	
Bottom	Fixed	15	1	49	20600	844	24.2	25.2	0.345	0.434	
Bottom	Fixed	15	25	12	20450	829	23.06	24.2	0.303	0.394	
Note: 1. When the reported SAR of the Mid channel for the exposure configuration is ≤ 0.8 W/kg, no further SAR testing is required in other channel.											

LTE Band 7 Body SAR											
SAR MEASUREMENT											
Liquid Temperature (°C): 22.3 ±2						Relative Humidity (%): 52					
Ambient Temperature (°C): 23.1 ±2						Depth of Liquid (cm): >15					
Test Position	Antenna Position	Dist (mm)	RB	RB offset	Frequency		Conducted Power (dBm)		SAR 1g (W/Kg)		Plot No.
					Channel	MHz	Measurement	Tune-up Limit	Measurement	Tune-up Scaled	
Test Mode: LTE Band 7 QPSK 20M Speed_0mm											
Bottom	Fixed	0	1	0	20850	2510	17.01	18	0.909	1.142	11
Bottom	Fixed	0	1	0	21100	2535	17.22	18	0.924	1.106	
Bottom	Fixed	0	1	0	21350	2560	17.01	18	0.879	1.104	
Bottom	Fixed	0	50	0	20850	2510	17.03	18	0.885	1.106	
Bottom	Fixed	0	50	0	21100	2535	17.12	18	0.919	1.125	
Bottom	Fixed	0	50	0	21350	2560	16.99	18	0.895	1.129	
Bottom	Fixed	0	100	0	20850	2510	16.99	18	0.871	1.099	
Bottom	Fixed	0	100	0	21100	2535	17.06	18	0.907	1.126	
Bottom	Fixed	0	100	0	21350	2560	17	18	0.894	1.125	
Test Mode: LTE Band 7C QPSK 20M Speed_0mm											
Bottom	Fixed	0	1	0	21001	2535	17	18	0.895	1.127	
Test Mode: LTE Band 7 QPSK 20M Speed_15mm											
Bottom	Fixed	15	1	99	20850	2510	24.51	25.2	0.766	0.898	
Bottom	Fixed	15	1	99	21100	2535	24.61	25.2	0.928	1.063	
Bottom	Fixed	15	1	99	21350	2560	24.4	25.2	0.944	1.135	
Bottom	Fixed	15	50	50	20850	2510	23.56	24.2	0.753	0.873	
Bottom	Fixed	15	50	50	21100	2535	23.57	24.2	0.806	0.932	
Bottom	Fixed	15	50	50	21350	2560	23.39	24.2	0.783	0.944	
Bottom	Fixed	15	100	0	20850	2510	23.57	24.2	0.729	0.843	
Bottom	Fixed	15	100	0	21100	2535	23.6	24.2	0.803	0.922	
Bottom	Fixed	15	100	0	21350	2560	23.4	24.2	0.783	0.941	
Test Mode: LTE Band 7C QPSK 20M Speed_15mm											
Bottom	Fixed	0	1	99	21001	2535	23.55	25.2	0.408	0.597	
Note: 1. When the reported SAR of the Mid channel for the exposure configuration is ≤ 0.8 W/kg, no further SAR testing is required in other channel.											

LTE Band 12 Body SAR											
SAR MEASUREMENT											
Liquid Temperature (°C): 22.1 ±2						Relative Humidity (%): 52					
Ambient Temperature (°C): 23.2 ±2						Depth of Liquid (cm): >15					
Test Position	Antenna Position	Dist (mm)	RB	RB offset	Frequency		Conducted Power (dBm)		SAR 1g (W/Kg)		Plot No.
					Channel	MHz	Measurement	Tune-up Limit	Measurement	Tune-up Scaled	
Test Mode: LTE Band 12 QPSK 10M Speed_0mm											
Bottom	Fixed	0	1	49	23060	704	19.41	21	0.545	0.786	
Bottom	Fixed	0	1	49	23095	707.5	19.51	21	0.557	0.785	
Bottom	Fixed	0	1	49	23130	711	19.1	21	0.561	0.869	12
Bottom	Fixed	0	25	0	23060	704	19.02	21	0.540	0.852	
Bottom	Fixed	0	25	0	23095	707.5	19.12	21	0.562	0.866	
Bottom	Fixed	0	25	0	23130	711	19.1	21	0.555	0.860	
Bottom	Fixed	0	50	0	23060	704	19	21	0.543	0.861	
Bottom	Fixed	0	50	0	23095	707.5	19.13	21	0.562	0.864	
Bottom	Fixed	0	50	0	23130	711	19.07	21	0.552	0.861	
Test Mode: LTE Band 12 QPSK 10M Speed_15mm											
Bottom	Fixed	15	1	49	23060	704	23.85	25.2	0.378	0.516	
Bottom	Fixed	15	1	49	23095	707.5	23.94	25.2	0.383	0.512	
Bottom	Fixed	15	1	49	23130	711	23.91	25.2	0.390	0.525	
Bottom	Fixed	15	25	25	23130	711	22.88	24.2	0.306	0.415	
Note: 1. When the reported SAR of the Mid channel for the exposure configuration is ≤ 0.8 W/kg, no further SAR testing is required in other channel.											

LTE Band 13 Body SAR											
SAR MEASUREMENT											
Liquid Temperature (°C): 22.1 ±2						Relative Humidity (%): 52					
Ambient Temperature (°C): 23.2 ±2						Depth of Liquid (cm): >15					
Test Position	Antenna Position	Dist (mm)	RB	RB offset	Frequency		Conducted Power (dBm)		SAR 1g (W/Kg)		Plot No.
					Channel	MHz	Measurement	Tune-up Limit	Measurement	Tune-up Scaled	
Test Mode: LTE Band 13 QPSK 10M Speed_0mm											
Bottom	Fixed	0	1	0	23230	782	19.75	21	0.677	0.903	
Bottom	Fixed	0	25	0	23230	782	19.52	21	0.673	0.946	13
Bottom	Fixed	0	50	0	23230	782	19.56	21	0.676	0.942	
Test Mode: LTE Band 13 QPSK 10M Speed_15mm											
Bottom	Fixed	15	1	0	23230	782	24.25	25.2	0.423	0.526	
Bottom	Fixed	15	25	12	23230	782	23.29	24.2	0.347	0.428	
Note: 1. When the reported SAR of the Mid channel for the exposure configuration is ≤ 0.8 W/kg, no further SAR testing is required in other channel.											

LTE Band 14 Body SAR											
SAR MEASUREMENT											
Liquid Temperature (°C): 22.1 ±2						Relative Humidity (%): 54					
Ambient Temperature (°C): 23.3 ±2						Depth of Liquid (cm): >15					
Test Position	Antenna Position	Dist (mm)	RB	RB offset	Frequency		Conducted Power (dBm)		SAR 1g (W/Kg)		Plot No.
					Channel	MHz	Measurement	Tune-up Limit	Measurement	Tune-up Scaled	
Test Mode: LTE Band 14 QPSK 10M Speed_0mm											
Bottom	Fixed	0	1	0	23330	793	19.78	21	0.723	0.957	14
Bottom	Fixed	0	25	0	23330	793	19.79	21	0.721	0.953	
Bottom	Fixed	0	50	0	23330	793	19.77	21	0.719	0.954	
Test Mode: LTE Band 14 QPSK 10M Speed_15mm											
Bottom	Fixed	15	1	0	23330	793	24.04	25.2	0.441	0.576	
Bottom	Fixed	15	25	12	23330	793	22.97	24.2	0.353	0.469	
Note: 1. When the reported SAR of the Mid channel for the exposure configuration is ≤ 0.8 W/kg, no further SAR testing is required in other channel.											

LTE Band 17 Body SAR											
SAR MEASUREMENT											
Liquid Temperature (°C): 22.1 ±2							Relative Humidity (%): 54				
Ambient Temperature (°C): 23.3 ±2							Depth of Liquid (cm): >15				
Test Position	Antenna Position	Dist (mm)	RB	RB offset	Frequency		Conducted Power (dBm)		SAR 1g (W/Kg)		Plot No.
					Channel	MHz	Measurement	Tune-up Limit	Measurement	Tune-up Scaled	
Test Mode: LTE Band 17 QPSK 10M Speed_0mm											
Bottom	Fixed	0	1	49	23780	709	19.36	21	0.639	0.932	15
Bottom	Fixed	0	1	49	23790	710	19.86	21	0.641	0.833	
Bottom	Fixed	0	1	49	23800	711	19.83	21	0.634	0.83	
Bottom	Fixed	0	25	25	23780	709	19.24	21	0.618	0.927	
Bottom	Fixed	0	25	25	23790	710	19.25	21	0.619	0.926	
Bottom	Fixed	0	25	25	23800	711	19.35	21	0.629	0.920	
Bottom	Fixed	0	50	0	23780	709	19.31	21	0.619	0.913	
Bottom	Fixed	0	50	0	23790	710	19.34	21	0.621	0.910	
Bottom	Fixed	0	50	0	23800	711	19.32	21	0.630	0.928	
Test Mode: LTE Band 17 QPSK 10M Speed_15mm											
Bottom	Fixed	15	1	49	23780	709	23.48	25.2	0.386	0.574	
Bottom	Fixed	15	1	49	23790	710	23.76	25.2	0.389	0.542	
Bottom	Fixed	15	1	49	23800	711	23.59	25.2	0.388	0.562	
Bottom	Fixed	15	25	25	23800	711	22.68	24.2	0.324	0.460	
Note: 1. When the reported SAR of the Mid channel for the exposure configuration is ≤ 0.8 W/kg, no further SAR testing is required in other channel.											

LTE Band 25 Body SAR											
SAR MEASUREMENT											
Liquid Temperature (°C): 22.3 ±2						Relative Humidity (%): 52					
Ambient Temperature (°C): 23.1 ±2						Depth of Liquid (cm): >15					
Test Position	Antenna Position	Dist (mm)	RB	RB offset	Frequency		Conducted Power (dBm)		SAR 1g (W/Kg)		Plot No.
					Channel	MHz	Measurement	Tune-up Limit	Measurement	Tune-up Scaled	
Test Mode: LTE Band 25 QPSK 20M Speed_0mm											
Bottom	Fixed	0	1	0	26140	1860	16.14	17.5	0.607	0.830	
Bottom	Fixed	0	1	0	26365	1882.5	16.23	17.5	0.588	0.788	
Bottom	Fixed	0	1	0	26590	1905	16.13	17.5	0.611	0.838	16
Bottom	Fixed	0	50	50	26140	1860	16.05	17.5	0.585	0.817	
Bottom	Fixed	0	50	50	26365	1882.5	16.09	17.5	0.583	0.807	
Bottom	Fixed	0	50	50	26590	1905	16.05	17.5	0.597	0.834	
Bottom	Fixed	0	100	0	26140	1860	15.98	17.5	0.587	0.833	
Bottom	Fixed	0	100	0	26365	1882.5	16.06	17.5	0.580	0.808	
Bottom	Fixed	0	100	0	26590	1905	16.05	17.5	0.597	0.834	
Test Mode: LTE Band 25 QPSK 20M Speed_15mm											
Bottom	Fixed	15	1	0	26140	1860	24.25	25.7	0.473	0.660	
Bottom	Fixed	15	1	0	26365	1882.5	24.35	25.7	0.539	0.736	
Bottom	Fixed	15	1	0	26590	1905	24.2	25.7	0.503	0.711	
Bottom	Fixed	15	50	50	26365	1882.5	23.47	24.7	0.430	0.571	
Note: 1. When the reported SAR of the Mid channel for the exposure configuration is ≤ 0.8 W/kg, no further SAR testing is required in other channel.											

LTE Band 26 Body SAR											
SAR MEASUREMENT											
Liquid Temperature (°C): 22.1 ±2								Relative Humidity (%): 54			
Ambient Temperature (°C): 23.3 ±2								Depth of Liquid (cm): >15			
Test Position	Antenna Position	Dist (mm)	RB	RB offset	Frequency		Conducted Power (dBm)		SAR 1g (W/Kg)		Plot No.
					Channel	MHz	Measurement	Tune-up Limit	Measurement	Tune-up Scaled	
Test Mode: LTE Band 26 QPSK 15M Speed_0mm											
Bottom	Fixed	0	1	74	26765	821.5	19.55	21	0.650	0.908	17
Bottom	Fixed	0	1	74	26865	831.5	19.62	21	0.608	0.835	
Bottom	Fixed	0	1	74	26965	841.5	19.56	21	0.595	0.829	
Bottom	Fixed	0	36	37	26765	821.5	19.49	21	0.611	0.865	
Bottom	Fixed	0	36	37	26865	831.5	19.56	21	0.607	0.846	
Bottom	Fixed	0	36	37	26965	841.5	19.49	21	0.593	0.840	
Bottom	Fixed	0	75	0	26765	821.5	19.61	21	0.644	0.887	
Bottom	Fixed	0	75	0	26865	831.5	19.58	21	0.599	0.831	
Bottom	Fixed	0	75	0	26965	841.5	19.55	21	0.593	0.828	
Test Mode: LTE Band 26 QPSK 15M Speed_15mm											
Bottom	Fixed	15	1	0	26765	821.5	23.84	25.2	0.427	0.584	
Bottom	Fixed	15	1	0	26865	831.5	23.96	25.2	0.429	0.571	
Bottom	Fixed	15	1	0	26965	841.5	23.76	25.2	0.396	0.552	
Bottom	Fixed	15	36	0	26865	831.5	22.88	24.2	0.341	0.462	
Note: 1. When the reported SAR of the Mid channel for the exposure configuration is ≤ 0.8 W/kg, no further SAR testing is required in other channel.											

LTE Band 30 Body SAR											
SAR MEASUREMENT											
Liquid Temperature (°C): 22.3 ±2						Relative Humidity (%): 52					
Ambient Temperature (°C): 23.1 ±2						Depth of Liquid (cm): >15					
Test Position	Antenna Position	Dist (mm)	RB	RB offset	Frequency		Conducted Power (dBm)		SAR 1g (W/Kg)		Plot No.
					Channel	MHz	Measurement	Tune-up Limit	Measurement	Tune-up Scaled	
Test Mode: LTE Band 30 QPSK 10M Speed_0mm											
Bottom	Fixed	0	1	25	27710	2310	14.86	16.5	0.632	0.922	
Bottom	Fixed	0	25	12	27710	2310	14.8	16.5	0.622	0.920	
Bottom	Fixed	0	50	0	27710	2310	14.76	16.5	0.617	0.921	
Test Mode: LTE Band 30 QPSK 10M Speed_15mm											
Bottom	Fixed	15	1	25	27710	2310	22.69	24	0.738	0.998	18
Bottom	Fixed	15	25	12	27710	2310	21.41	23	0.525	0.757	
Bottom	Fixed	15	50	0	27710	2310	21.42	23	0.525	0.755	
Note: 1. When the reported SAR of the Mid channel for the exposure configuration is ≤ 0.8 W/kg, no further SAR testing is required in other channel.											

LTE Band 38 Body SAR											
SAR MEASUREMENT											
Liquid Temperature (°C): 22.3 ±2						Relative Humidity (%): 52					
Ambient Temperature (°C): 23.1 ±2						Depth of Liquid (cm): >15					
Test Position	Antenna Position	Dist (mm)	RB	RB offset	Frequency		Conducted Power (dBm)		SAR 1g (W/Kg)		Plot No.
					Channel	MHz	Measurement	Tune-up Limit	Measurement	Tune-up Scaled	
Test Mode: LTE Band 38 QPSK 20M Speed_0mm											
Bottom	Fixed	0	1	0	37850	2580	18.7	20	0.531	0.716	
Bottom	Fixed	0	1	0	38000	2595	18.73	20	0.522	0.699	
Bottom	Fixed	0	1	0	38150	2610	18.71	20	0.491	0.661	
Bottom	Fixed	0	50	25	38000	2595	18.65	20	0.518	0.707	
Test Mode: LTE Band 38C QPSK 20M Speed_0mm											
Bottom	Fixed	0	1	0	37901	2595	18.69	20	0.513	0.694	
Test Mode: LTE Band 38 QPSK 20M Speed_15mm											
Bottom	Fixed	15	1	0	37850	2580	23.9	25.2	0.615	0.830	19
Bottom	Fixed	15	1	0	38000	2595	23.98	25.2	0.602	0.797	
Bottom	Fixed	15	1	0	38150	2610	23.83	25.2	0.605	0.829	
Bottom	Fixed	15	50	0	38000	2595	23.14	24.2	0.491	0.627	
Bottom	Fixed	15	100	0	38000	2595	23.08	24.2	0.341	0.441	
Test Mode: LTE Band 38C QPSK 20M Speed_15mm											
Bottom	Fixed	15	1	0	37901	2595	23.55	25.2	0.165	0.241	
Note: 1. When the reported SAR of the Mid channel for the exposure configuration is ≤ 0.8 W/kg, no further SAR testing is required in other channel.											

LTE Band 41 Body SAR											
SAR MEASUREMENT											
Liquid Temperature (°C): 22.3 ±2								Relative Humidity (%): 52			
Ambient Temperature (°C): 23.1 ±2								Depth of Liquid (cm): >15			
Test Position	Antenna Position	Dist (mm)	RB	RB offset	Frequency		Conducted Power (dBm)		SAR 1g (W/Kg)		Plot No.
					Channel	MHz	Measurement	Tune-up Limit	Measurement	Tune-up Scaled	
Test Mode: LTE Band 41 QPSK 20M Speed_0mm											
Bottom	Fixed	0	1	99	39750	2506	18.75	20	0.842	1.123	
Bottom	Fixed	0	1	99	40620	2593	18.85	20	0.792	1.032	
Bottom	Fixed	0	1	99	41490	2680	18.67	20	0.686	0.932	
Bottom	Fixed	0	50	25	39750	2506	18.68	20	0.811	1.099	
Bottom	Fixed	0	50	25	40620	2593	18.66	20	0.749	1.020	
Bottom	Fixed	0	50	25	41490	2680	18.65	20	0.688	0.939	
Bottom	Fixed	0	100	0	39750	2506	18.69	20	0.828	1.120	
Bottom	Fixed	0	100	0	40620	2593	18.7	20	0.787	1.062	
Bottom	Fixed	0	100	0	41490	2680	18.57	20	0.670	0.931	
Test Mode: LTE Band 41(PC2) QPSK 20M Speed_0mm											
Bottom	Fixed	0	1	50	39750	2506	20.9	22	0.885	1.140	20
Bottom	Fixed	0	1	50	40620	2593	20.96	22	0.838	1.065	
Bottom	Fixed	0	1	50	41490	2680	20.89	22	0.718	0.927	
Bottom	Fixed	0	50	25	39750	2506	20.88	22	0.879	1.138	
Bottom	Fixed	0	50	25	40620	2593	20.75	22	0.847	1.129	
Bottom	Fixed	0	50	25	41490	2680	20.66	22	0.735	1.001	
Bottom	Fixed	0	100	0	39750	2506	20.79	22	0.860	1.136	
Bottom	Fixed	0	100	0	40620	2593	20.77	22	0.820	1.088	
Bottom	Fixed	0	100	0	41490	2680	20.56	22	0.718	1.000	
Test Mode: LTE Band 41C QPSK 20M Speed_0mm											
Bottom	Fixed	0	1	99	40521	2593	18.52	20	0.530	0.745	
Test Mode: LTE Band 41 QPSK 20M Speed_15mm											
Bottom	Fixed	15	1	0	39750	2506	24.15	25.2	0.468	0.596	
Bottom	Fixed	15	1	0	40620	2593	24.22	25.2	0.602	0.754	
Bottom	Fixed	15	1	0	41490	2680	23.8	25.2	0.465	0.642	
Bottom	Fixed	15	50	0	40620	2593	23.31	24.2	0.491	0.603	

Test Mode: LTE Band 41(PC2) QPSK 20M Speed_15mm											
Bottom	Fixed	15	1	0	39750	2506	26.05	27.2	0.616	0.803	
Bottom	Fixed	15	1	0	40620	2593	26.06	27.2	0.698	0.908	
Bottom	Fixed	15	1	0	41490	2680	25.69	27.2	0.590	0.835	
Bottom	Fixed	15	50	25	40620	2593	25.3	26.2	0.508	0.625	
Bottom	Fixed	15	100	0	40620	2593	25.32	26.2	0.541	0.663	
Test Mode: LTE Band 41C QPSK 20M Speed_15mm											
Bottom	Fixed	15	1	0	40521	2593	23.05	25.2	0.172	0.282	
<p>Note: 1. When the reported SAR of the Mid channel for the exposure configuration is ≤ 0.8 W/kg, no further SAR testing is required in other channel.</p>											

LTE Band 66 Body SAR											
SAR MEASUREMENT											
Liquid Temperature (°C): 22.4 ±2						Relative Humidity (%): 51					
Ambient Temperature (°C): 23.1 ±2						Depth of Liquid (cm): >15					
Test Position	Antenna Position	Dist (mm)	RB	RB offset	Frequency		Conducted Power (dBm)		SAR 1g (W/Kg)		Plot No.
					Channel	MHz	Measurement	Tune-up Limit	Measurement	Tune-up Scaled	
Test Mode: LTE Band 66 QPSK 20M Speed_0mm											
Bottom	Fixed	0	1	0	132072	1720	15.81	17	0.563	0.740	
Bottom	Fixed	0	1	0	132322	1745	15.89	17	0.572	0.739	
Bottom	Fixed	0	1	0	132572	1770	15.73	17	0.595	0.797	21
Bottom	Fixed	0	50	0	132072	1720	15.8	17	0.556	0.733	
Bottom	Fixed	0	50	0	132322	1745	15.75	17	0.566	0.755	
Bottom	Fixed	0	50	0	132572	1770	15.72	17	0.586	0.787	
Test Mode: LTE Band 66 QPSK 20M Speed_15mm											
Bottom	Fixed	15	1	0	132072	1720	23.96	25.2	0.480	0.639	
Bottom	Fixed	15	1	0	132322	1745	23.99	25.2	0.485	0.641	
Bottom	Fixed	15	1	0	132572	1770	23.76	25.2	0.462	0.644	
Bottom	Fixed	15	50	0	132322	1745	22.95	24.2	0.425	0.567	
Note: 1. When the reported SAR of the Mid channel for the exposure configuration is ≤ 0.8 W/kg, no further SAR testing is required in other channel.											

LTE Band 71 Body SAR											
SAR MEASUREMENT											
Liquid Temperature (°C): 22.1 ±2							Relative Humidity (%): 54				
Ambient Temperature (°C): 23.3 ±2							Depth of Liquid (cm): >15				
Test Position	Antenna Position	Dist (mm)	RB	RB offset	Frequency		Conducted Power (dBm)		SAR 1g (W/Kg)		Plot No.
					Channel	MHz	Measurement	Tune-up Limit	Measurement	Tune-up Scaled	
Test Mode: LTE Band 71 QPSK 20M Speed_0mm											
Bottom	Fixed	0	1	50	133222	673	19.21	21	0.691	1.043	22
Bottom	Fixed	0	1	50	133322	683	19.49	21	0.683	0.967	
Bottom	Fixed	0	1	50	133372	688	19.27	21	0.672	1.001	
Bottom	Fixed	0	50	25	133222	673	19.36	21	0.661	0.964	
Bottom	Fixed	0	50	25	133322	683	19.42	21	0.668	0.961	
Bottom	Fixed	0	50	25	133372	688	19.15	21	0.662	1.014	
Bottom	Fixed	0	100	0	133222	673	19.33	21	0.519	0.762	
Bottom	Fixed	0	100	0	133322	683	19.48	21	0.679	0.964	
Bottom	Fixed	0	100	0	133372	688	19.22	21	0.669	1.008	
Test Mode: LTE Band 71 QPSK 20M Speed_15mm											
Bottom	Fixed	15	1	0	133222	673	23.87	25.2	0.430	0.584	
Bottom	Fixed	15	1	0	133322	683	23.93	25.2	0.445	0.596	
Bottom	Fixed	15	1	0	133372	688	23.87	25.2	0.433	0.588	
Bottom	Fixed	15	50	50	133322	683	22.87	24.2	0.335	0.455	
Note: 1. When the reported SAR of the Mid channel for the exposure configuration is ≤ 0.8 W/kg, no further SAR testing is required in other channel.											

10.2 Simultaneous Transmission

Simultaneous Transmission Configurations	
1	WLAN 2.4GHz Main + WLAN 2.4GHz Aux
2	WLAN 5GHz Main + WLAN 5GHz Aux
3	WWAN + WLAN 2.4GHz Main + WLAN 2.4GHz Aux
4	WWAN + WLAN 5GHz Main + WLAN 5GHz Aux + BT

Worst Case SAR

WWAN Band	Bottom_0mm	Bottom_15mm
WCDMA B2	0.930	0.822
WCDMA B5	1.011	0.529
LTE Band 2	0.815	0.686
LTE Band 4	0.766	0.739
LTE Band 5	0.843	0.464
LTE Band 7	1.142	1.135
LTE Band 12	0.869	0.525
LTE Band 13	0.946	0.526
LTE Band 14	0.957	0.576
LTE Band 17	0.932	0.574
LTE Band 25	0.838	0.736
LTE Band 26	0.908	0.584
LTE Band 30	0.922	0.998
LTE Band 38	0.716	0.830
LTE Band 41	1.123	0.754
LTE Band 41(PC2)	1.140	0.908
LTE Band 66	0.797	0.644
LTE Band 71	1.043	0.596
WLAN Band	Bottom_0mm	Bottom_15mm
WLAN2.4G Main	0.013	--
WLAN2.4G Aux	0.026	--
WLAN5G Main	0.097	--
WLAN5G Aux	0.072	--
BT	0.015	--

10.2.1 Simultaneous transmission of MIMO in 802.11 test exclusion considerations

Frequency (GHz)	Test Position (Body)	WLAN Main SAR (W/Kg)	WLAN Aux SAR (W/Kg)	Simultaneous Transmission (W/Kg)	Antenna pair in mm	Peak location separation ratio
2.4	Bottom	0.013	0.026	0.039	N/A	N/A
5	Bottom	0.097	0.072	0.169	N/A	N/A

Note: The sum of value is less than 1.6 W/Kg or the ratio is determined by $(SAR1 + SAR2)^{1.5}/R_i$, rounded to two decimal digits, and must be ≤ 0.04 for all antenna pairs in the configuration to qualify for SAR test exclusion.

10.2.2 Simultaneous transmission of Wi-Fi and other wireless technologies

Simultaneous Transmission Summation Scenario

Test Position	Worst Case WWAN Band	1	2	3	4	5	6	1+2+3	1+4+5+6
		WWAN (W/Kg)	DTS Main (W/Kg)	DTS Aux (W/Kg)	UNII Main (W/Kg)	UNII Aux (W/Kg)	BT (W/Kg)	Σ 1-g SAR	Σ 1-g SAR
Bottom_0mm	LTE Band 7	1.142	0.013	0.026	0.097	0.072	0.015	1.181	1.326
Bottom_15mm	LTE Band 7	1.135	0.013	0.026	0.097	0.072	0.015	1.174	1.319

Note: The sum of value is less than 1.6 W/Kg, thus simultaneous SAR testing is not need.

11. SAR measurement variability

- 1) Repeated measurement is not required when the original highest measured SAR is < 0.80 W/kg; steps 2) through 4) do not apply.
- 2) When the original highest measured SAR is ≥ 0.80 W/kg, repeat that measurement once.
- 3) Perform a second repeated measurement only if the ratio of largest to smallest SAR for the original and first repeated measurements is > 1.20 or when the original or repeated measurement is ≥ 1.45 W/kg (~ 10% from the 1-g SAR limit).
- 4) Perform a third repeated measurement only if the original, first or second repeated measurement is ≥ 1.5 W/kg and the ratio of largest to smallest SAR for the original, first and second repeated measurements is > 1.20 .

Frequency				SAR 1g (W/kg)							
Mode	Band	Channel	MHz	Original	First Repeated		Second Repeated		Third Repeated		
					Value	Ratio	Value	Ratio	Value	Ratio	
LTE	B7	21350	2560	0.944	0.919	1.027	N/A	N/A	N/A	N/A	
LTE	B41	39750	2506	0.885	0.884	1.001	N/A	N/A	N/A	N/A	

Appendix

Appendix A. SAR System Check Data

Appendix B. SAR measurement Data

Appendix C. Test Setup Photographs

Appendix D. Probe Calibration Data

Appendix E. Dipole Calibration Data

Appendix F. Product Photos-Please refer to the file: 2210618R-Product Photos

Appendix A. SAR System Check Data

Test Laboratory: DEKRA

Date: 2022/02/22

System Performance Check_750MHz-Head

DUT: Dipole 750 MHz; Type: D750V3

Communication System: UID 0, CW; Frequency: 750 MHz;

Communication System PAR: 0 dB

Medium parameters used: $f = 750$ MHz; $\sigma = 0.88$ S/m; $\epsilon_r = 42.33$; $\rho = 1000$ kg/m³

Phantom section: Flat Section

Ambient Temperature (°C) : 23.2, Liquid Temperature (°C) : 22.1

Measurement Standard: DASYS (IEEE/IEC/ANSI C63.19-2011)

DASY5 Configuration:

- Probe: EX3DV4 - SN3698; ConvF(9.1, 9.1, 9.1); Calibrated: 2021/11/24;
- Sensor-Surface: 1.4mm (Mechanical Surface Detection)
- Electronics: DAE4 Sn1207; Calibrated: 2021/11/22
- Phantom: SAM with left table; Type: SAM;
- Measurement SW: DASYS2, Version 52.10 (0); SEMCAD X Version 14.6.10 (7417)

Configuration/750MHz Head/Area Scan (8x13x1): Measurement grid: dx=15mm, dy=15mm

Maximum value of SAR (measured) = 2.56 W/kg

Configuration/750MHz Head/Zoom Scan (5x5x7)/Cube 0: Measurement grid: dx=8mm, dy=8mm, dz=5mm

Reference Value = 59.24 V/m; Power Drift = 0.05dB

Peak SAR (extrapolated) = 3.25 W/kg

SAR(1 g) = 2.07W/kg; SAR(10 g) = 1.34W/kg

Maximum value of SAR (measured) = 2.96 W/kg

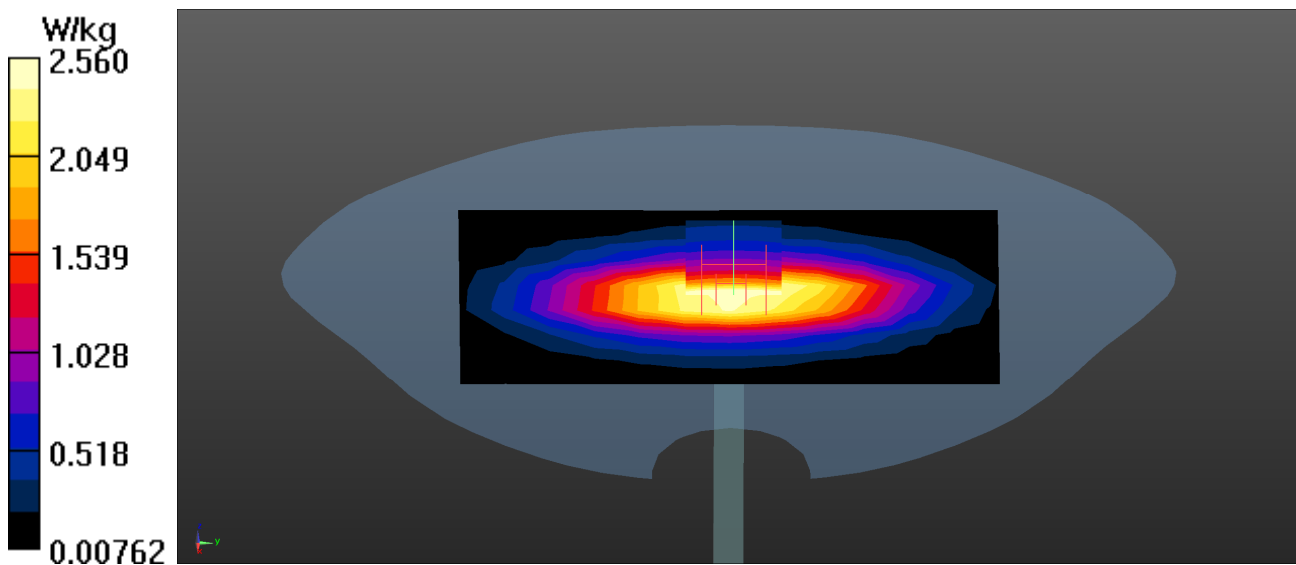

Test Laboratory: DEKRA

Date: 2022/03/07

System Performance Check_750MHz-Head**DUT: Dipole 750 MHz; Type: D750V3**

Communication System: UID 0, CW; Frequency: 750 MHz;

Communication System PAR: 0 dB

Medium parameters used: $f = 750$ MHz; $\sigma = 0.89$ S/m; $\epsilon_r = 42.28$; $\rho = 1000$ kg/m³

Phantom section: Flat Section

Ambient Temperature (°C) : 23.2, Liquid Temperature (°C) : 22.1

Measurement Standard: DASY5 (IEEE/IEC/ANSI C63.19-2011)

DASY5 Configuration:

- Probe: EX3DV4 - SN3698; ConvF(9.1, 9.1, 9.1); Calibrated: 2021/11/24;
- Sensor-Surface: 1.4mm (Mechanical Surface Detection)
- Electronics: DAE4 Sn1207; Calibrated: 2021/11/22
- Phantom: SAM with left table; Type: SAM;
- Measurement SW: DASY52, Version 52.10 (0); SEMCAD X Version 14.6.10 (7417)

Configuration/750MHz Head/Area Scan (8x13x1): Measurement grid: dx=15mm, dy=15mm

Maximum value of SAR (measured) = 2.62 W/kg

Configuration/750MHz Head/Zoom Scan (5x5x7) (5x5x7)/Cube 0: Measurement grid: dx=8mm, dy=8mm, dz=5mm

Reference Value = 59.91 V/m; Power Drift = 0.01 dB

Peak SAR (extrapolated) = 3.54 W/kg

SAR(1 g) = 2.1 W/kg; SAR(10 g) = 1.36 W/kg

Maximum value of SAR (measured) = 2.96 W/kg

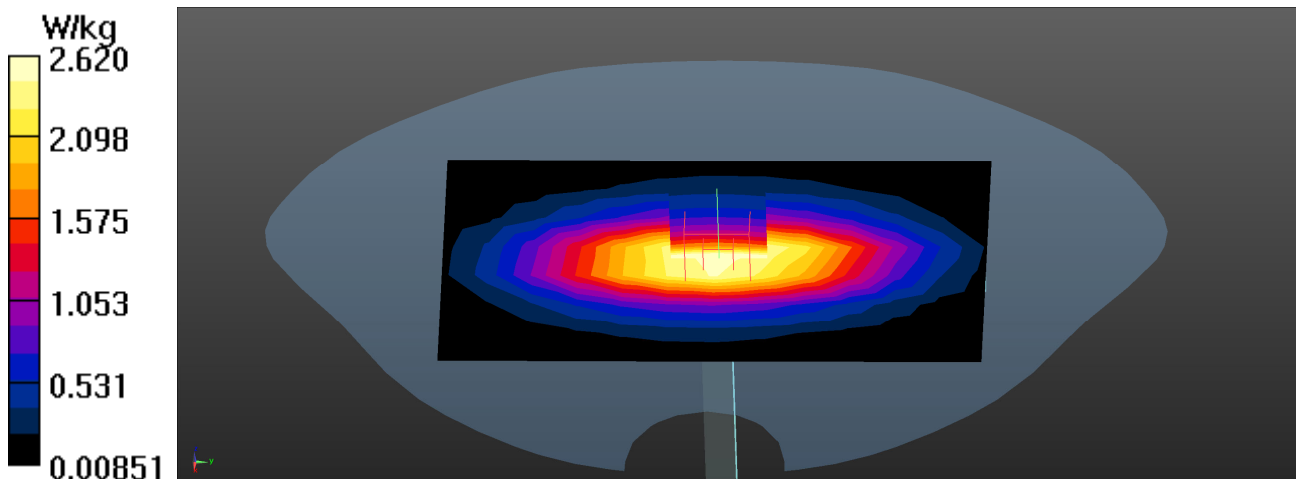

Test Laboratory: DEKRA

Date: 2022/03/08

System Performance Check_750MHz-Head**DUT: Dipole 750 MHz; Type: D750V3**

Communication System: UID 0, CW; Frequency: 750 MHz;

Communication System PAR: 0 dB

Medium parameters used: $f = 750$ MHz; $\sigma = 0.88$ S/m; $\epsilon_r = 41.97$; $\rho = 1000$ kg/m³

Phantom section: Flat Section

Ambient Temperature (°C) : 23.3, Liquid Temperature (°C) : 22.1

Measurement Standard: DASY5 (IEEE/IEC/ANSI C63.19-2011)

DASY5 Configuration:

- Probe: EX3DV4 - SN3698; ConvF(9.1, 9.1, 9.1); Calibrated: 2021/11/24;
- Sensor-Surface: 1.4mm (Mechanical Surface Detection)
- Electronics: DAE4 Sn1207; Calibrated: 2021/11/22
- Phantom: SAM with left table; Type: SAM;
- Measurement SW: DASY52, Version 52.10 (0); SEMCAD X Version 14.6.10 (7417)

Configuration/750MHz Head/Area Scan (8x13x1): Measurement grid: dx=15mm, dy=15mm

Maximum value of SAR (measured) = 2.19 W/kg

Configuration/750MHz Head/Zoom Scan (5x5x7)/Cube 0: Measurement grid: dx=8mm, dy=8mm, dz=5mm

Reference Value = 57.46 V/m; Power Drift = -0.05 dB

Peak SAR (extrapolated) = 3.23 W/kg

SAR(1 g) = 2.11 W/kg; SAR(10 g) = 1.42 W/kg

Maximum value of SAR (measured) = 2.54 W/kg

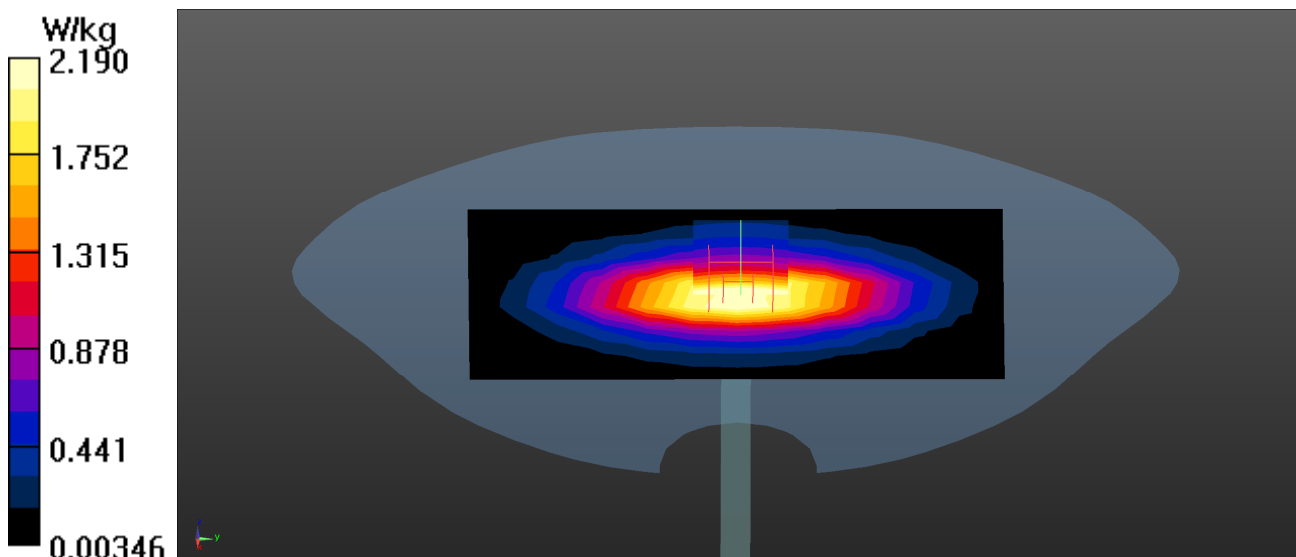

Test Laboratory: DEKRA

Date: 2022/02/23

System Performance Check_1750MHz-Head**DUT: Dipole 1750 MHz; Type: D1750V2**

Communication System: UID 0, CW; Frequency: 1750 MHz;

Communication System PAR: 0 dB

Medium parameters used: $f = 1750$ MHz; $\sigma = 1.35$ S/m; $\epsilon_r = 40.46$; $\rho = 1000$ kg/m³

Phantom section: Flat Section

Ambient Temperature (°C) : 23.1, Liquid Temperature (°C) : 22.4

Measurement Standard: DASYS (IEEE/IEC/ANSI C63.19-2011)

DASY5 Configuration:

- Probe: EX3DV4 - SN3698; ConvF(7.96, 7.96, 7.96); Calibrated: 2021/11/24;
- Sensor-Surface: 1.4mm (Mechanical Surface Detection)
- Electronics: DAE4 Sn1207; Calibrated: 2021/11/22
- Phantom: SAM with left table; Type: SAM;
- Measurement SW: DASYS2, Version 52.10 (0); SEMCAD X Version 14.6.10 (7417)

Configuration/1750MHz Head/Area Scan (8x8x1): Measurement grid: dx=15mm, dy=15mm

Maximum value of SAR (measured) = 12.5 W/kg

Configuration/1750MHz Head/Zoom Scan (5x5x7)/Cube 0: Measurement grid: dx=8mm, dy=8mm, dz=5mm

Reference Value = 103.7 V/m; Power Drift = 0.01 dB

Peak SAR (extrapolated) = 17.4 W/kg

SAR(1 g) = 9.79 W/kg; SAR(10 g) = 5.15 W/kg

Maximum value of SAR (measured) = 15.1 W/kg

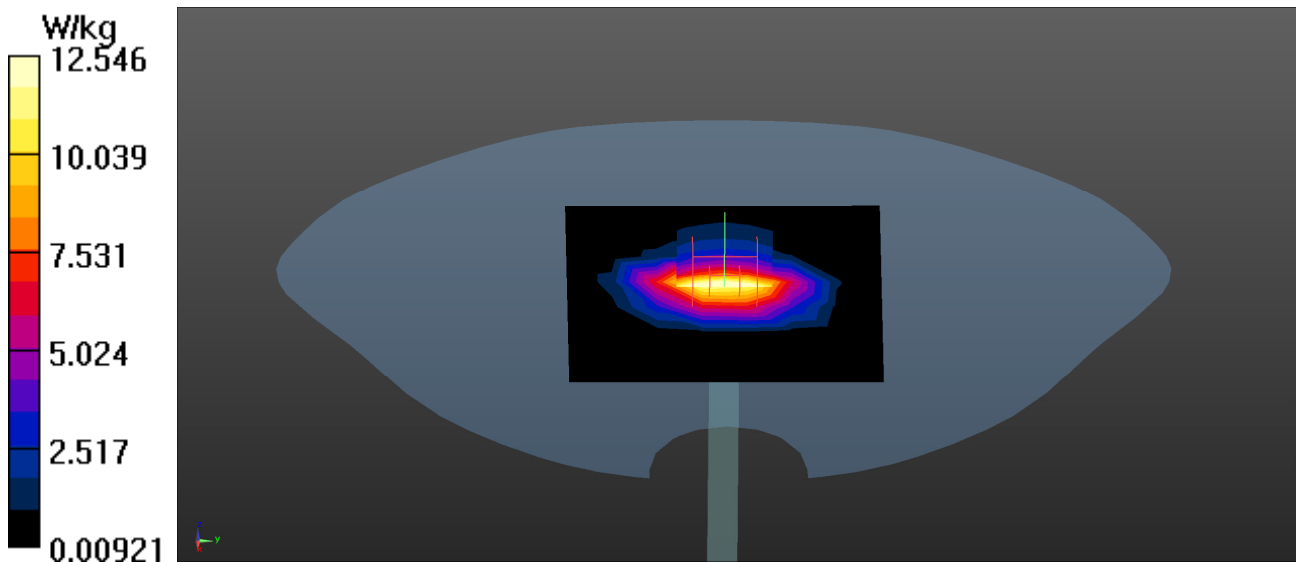

Test Laboratory: DEKRA

Date: 2022/02/23

System Performance Check_1950MHz-Head**DUT: Dipole 1950 MHz; Type: D1950V3**

Communication System: UID 0, CW ; Frequency: 1950 MHz;

Communication System PAR: 0 dB

Medium parameters used: $f = 1950$ MHz; $\sigma = 1.41$ S/m; $\epsilon_r = 39.48$; $\rho = 1000$ kg/m³

Phantom section: Flat Section

Ambient Temperature (°C) : 23.1, Liquid Temperature (°C) : 22.4

Measurement Standard: DASYS5 (IEEE/IEC/ANSI C63.19-2011)

DASY5 Configuration:

- Probe: EX3DV4 - SN3698; ConvF(7.6, 7.6, 7.6); Calibrated: 2021/11/24;
- Sensor-Surface: 1.4mm (Mechanical Surface Detection)
- Electronics: DAE4 Sn1207; Calibrated: 2021/11/22
- Phantom: SAM with left table; Type: SAM;
- Measurement SW: DASYS52, Version 52.10 (0); SEMCAD X Version 14.6.10 (7417)

Configuration/1950MHz Head/Area Scan (8x8x1): Measurement grid: dx=15mm, dy=15mm

Maximum value of SAR (measured) = 10.6 W/kg

Configuration/1950MHz Head/Zoom Scan (5x5x7)/Cube 0: Measurement grid: dx=8mm, dy=8mm, dz=5mm

Reference Value = 111.3 V/m; Power Drift = 0.08 dB

Peak SAR (extrapolated) = 18.0 W/kg

SAR(1 g) = 10.4 W/kg; SAR(10 g) = 5.24 W/kg

Maximum value of SAR (measured) = 16.5 W/kg

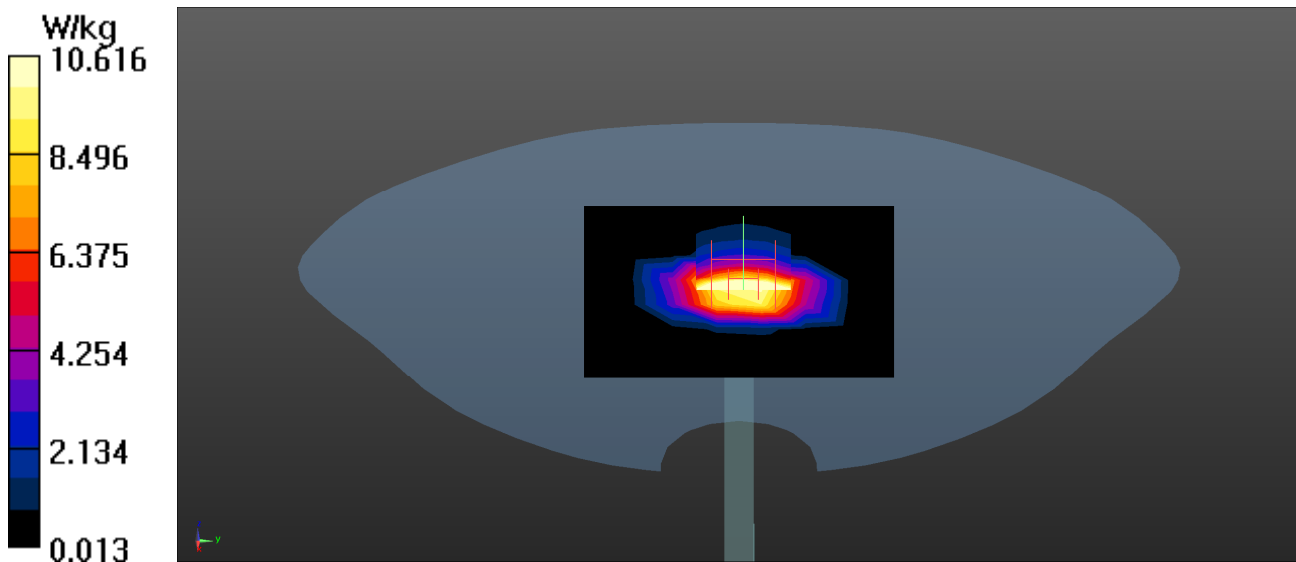

Test Laboratory: DEKRA

Date: 2022/03/09

System Performance Check_1950MHz-Head**DUT: Dipole 1950 MHz; Type: D1950V3**

Communication System: UID 0, CW (0); Frequency: 1950 MHz;

Communication System PAR: 0 dB

Medium parameters used: $f = 1950$ MHz; $\sigma = 1.39$ S/m; $\epsilon_r = 39.56$; $\rho = 1000$ kg/m³

Phantom section: Flat Section

Ambient Temperature (°C) : 23.1, Liquid Temperature (°C) : 22.3

Measurement Standard: DASYS5 (IEEE/IEC/ANSI C63.19-2011)

DASY5 Configuration:

- Probe: EX3DV4 - SN3698; ConvF(7.6, 7.6, 7.6); Calibrated: 2021/11/24;
- Sensor-Surface: 1.4mm (Mechanical Surface Detection)
- Electronics: DAE4 Sn1207; Calibrated: 2021/11/22
- Phantom: SAM with left table; Type: SAM;
- Measurement SW: DASYS52, Version 52.10 (0); SEMCAD X Version 14.6.10 (7417)

Configuration/1950MHz Head/Area Scan (8x8x1): Measurement grid: dx=15mm, dy=15mm

Maximum value of SAR (measured) = 12.4 W/kg

Configuration/1950MHz Head/Zoom Scan (5x5x7)/Cube 0: Measurement grid: dx=8mm, dy=8mm, dz=5mm

Reference Value = 113.3 V/m; Power Drift = 0.06 dB

Peak SAR (extrapolated) = 19.1 W/kg

SAR(1 g) = 10.1 W/kg; SAR(10 g) = 5.24 W/kg

Maximum value of SAR (measured) = 17.1 W/kg

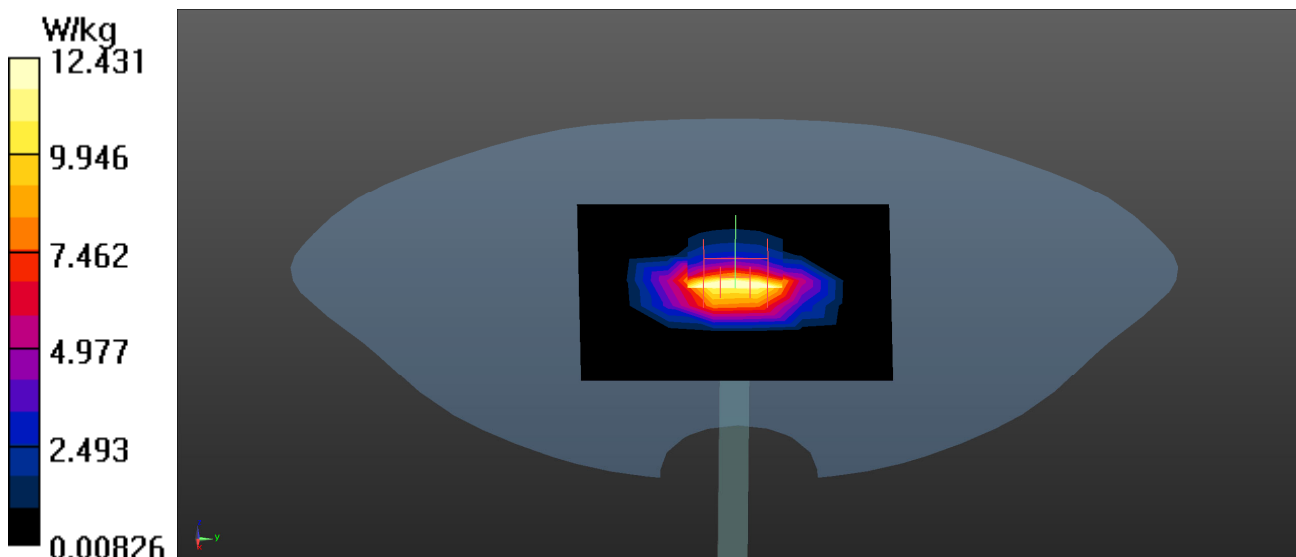

Test Laboratory: DEKRA

Date: 2022/03/09

System Performance Check_2300MHz-Head**DUT: Dipole 2300 MHz; Type: D2300V2**

Communication System: UID 0, CW; Frequency: 2300 MHz;

Communication System PAR: 0 dB

Medium parameters used: $f = 2300$ MHz; $\sigma = 1.66$ S/m; $\epsilon_r = 39.45$; $\rho = 1000$ kg/m³

Phantom section: Flat Section

Ambient Temperature (°C) : 23.1, Liquid Temperature (°C) : 22.3

Measurement Standard: DASYS5 (IEEE/IEC/ANSI C63.19-2011)

DASY5 Configuration:

- Probe: EX3DV4 - SN3698; ConvF(7.39, 7.39, 7.39); Calibrated: 2021/11/24;
- Sensor-Surface: 1.4mm (Mechanical Surface Detection)
- Electronics: DAE4 Sn1207; Calibrated: 2021/11/22
- Phantom: SAM with left table; Type: SAM;
- Measurement SW: DASYS52, Version 52.10 (0); SEMCAD X Version 14.6.10 (7417)

Configuration/2300MHz_Head/Area Scan (8x9x1): Measurement grid: dx=12mm, dy=12mm

Maximum value of SAR (measured) = 19.2 W/kg

Configuration/2300MHz_Head/Zoom Scan (7x7x7)/Cube 0: Measurement grid: dx=5mm, dy=5mm, dz=5mm

Reference Value = 114.0 V/m; Power Drift = 0.09 dB

Peak SAR (extrapolated) = 24.5 W/kg

SAR(1 g) = 12.1 W/kg; SAR(10 g) = 5.88 W/kg

Maximum value of SAR (measured) = 20.0 W/kg

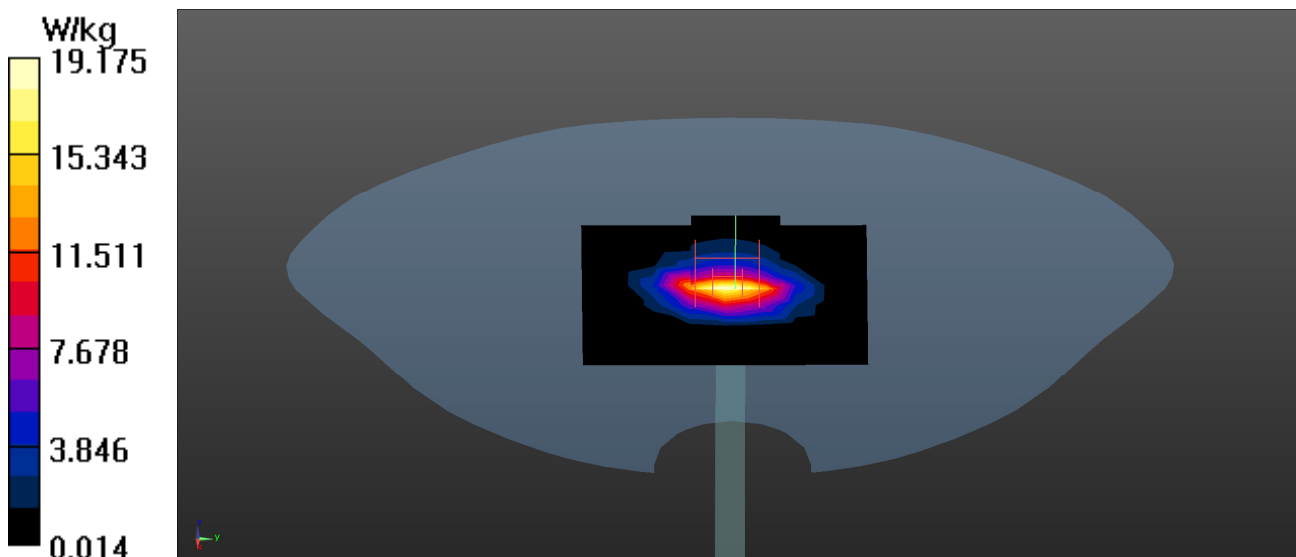

Test Laboratory: DEKRA

Date: 2022/02/16

System Performance Check_2450MHz-Head**DUT: Dipole 2450 MHz; Type: D2450V2**

Communication System: UID 10000, CW; Frequency: 2450 MHz;

Communication System PAR: 0 dB

Medium parameters used: $f = 2450$ MHz; $\sigma = 1.85$ S/m; $\epsilon_r = 39.67$; $\rho = 1000$ kg/m³

Phantom section: Flat Section

Ambient Temperature (°C) : 22.4, Liquid Temperature (°C) : 21.7

Measurement Standard: DASY5 (IEEE/IEC/ANSI C63.19-2011)

DASY5 Configuration:

- Probe: EX3DV4 - SN3698; ConvF(7.19, 7.19, 7.19); Calibrated: 2021/11/24;
- Sensor-Surface: 1.4mm (Mechanical Surface Detection)
- Electronics: DAE4 Sn1207; Calibrated: 2021/11/22
- Phantom: SAM with left table; Type: SAM
- Measurement SW: DASY52, Version 52.10 (0); SEMCAD X Version 14.6.10 (7417)

Configuration/2450MHz_Head/Area Scan (8x9x1): Measurement grid: dx=12mm, dy=12mm

Maximum value of SAR (measured) = 18.8 W/kg

Configuration/2450MHz_Head/Zoom Scan (7x7x7)/Cube 0: Measurement grid: dx=5mm, dy=5mm, dz=5mm

Reference Value = 117.8 V/m; Power Drift = 0.03 dB

Peak SAR (extrapolated) = 29.3 W/kg

SAR(1 g) = 13.6 W/kg; SAR(10 g) = 6.24 W/kg

Maximum value of SAR (measured) = 23.2 W/kg

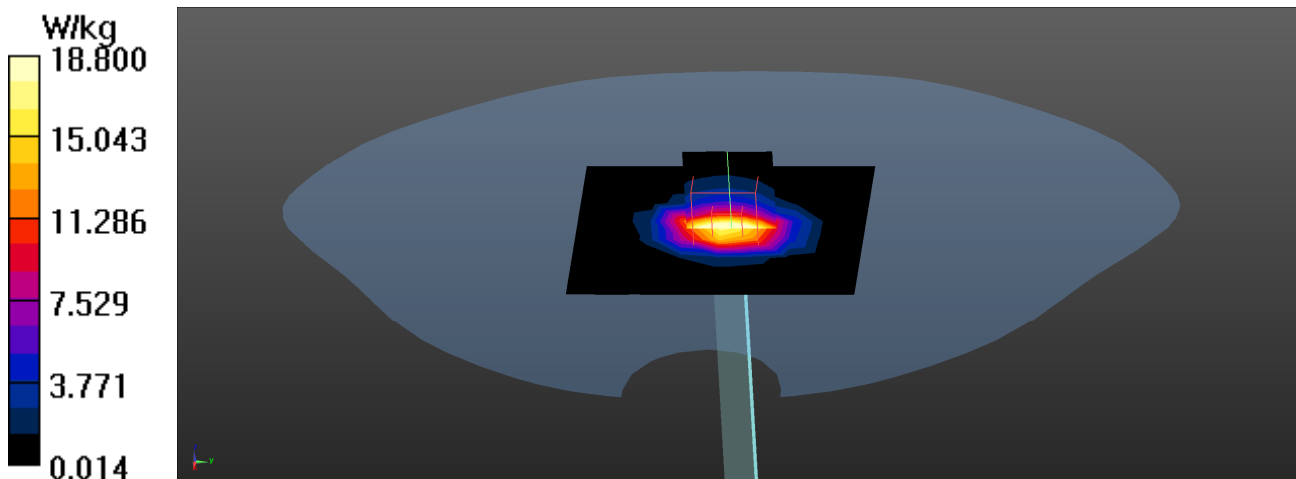

Test Laboratory: DEKRA

Date: 2022/03/11

System Performance Check_2450MHz-Head**DUT: Dipole 2450 MHz; Type: D2450V2**

Communication System: UID 10000, CW; Frequency: 2450 MHz;

Communication System PAR: 0 dB

Medium parameters used: $f = 2450$ MHz; $\sigma = 1.81$ S/m; $\epsilon_r = 38.52$; $\rho = 1000$ kg/m³

Phantom section: Flat Section

Ambient Temperature (°C) : 22.3, Liquid Temperature (°C) : 21.9

Measurement Standard: DASYS5 (IEEE/IEC/ANSI C63.19-2011)

DASY5 Configuration:

- Probe: EX3DV4 - SN3698; ConvF(7.19, 7.19, 7.19); Calibrated: 2021/11/24;
- Sensor-Surface: 1.4mm (Mechanical Surface Detection)
- Electronics: DAE4 Sn1207; Calibrated: 2021/11/22
- Phantom: SAM with left table; Type: SAM;
- Measurement SW: DASYS52, Version 52.10 (0); SEMCAD X Version 14.6.10 (7417)

Configuration/2450MHz_Head/Area Scan (8x9x1): Measurement grid: dx=12mm, dy=12mm

Maximum value of SAR (measured) = 19.3 W/kg

Configuration/2450MHz_Head/Zoom Scan (7x7x7)/Cube 0: Measurement grid: dx=5mm, dy=5mm, dz=5mm

Reference Value = 118.5 V/m; Power Drift = 0.03 dB

Peak SAR (extrapolated) = 30.0 W/kg

SAR(1 g) = 13.9 W/kg; SAR(10 g) = 6.38 W/kg

Maximum value of SAR (measured) = 23.7 W/kg

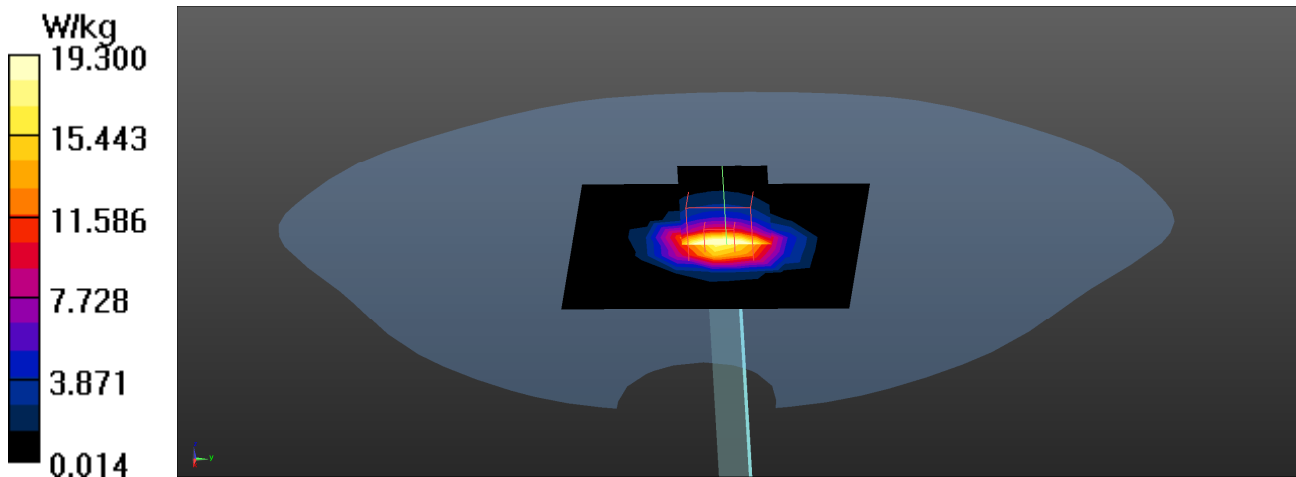

Test Laboratory: DEKRA

Date: 2022/03/09

System Performance Check_2600MHz-Head**DUT: Dipole_2600MHz; Type: ALS-D-2600-S-2**

Communication System: UID 0, CW; Frequency: 2600 MHz;

Communication System PAR: 0 dB

Medium parameters used: $f = 2600$ MHz; $\sigma = 1.94$ S/m; $\epsilon_r = 38.99$; $\rho = 1000$ kg/m³

Phantom section: Flat Section

Ambient Temperature (°C) : 23.1, Liquid Temperature (°C) : 22.3

Measurement Standard: DASY5 (IEEE/IEC/ANSI C63.19-2011)

DASY5 Configuration:

- Probe: EX3DV4 - SN3698; ConvF(6.97, 6.97, 6.97); Calibrated: 2021/11/24;
- Sensor-Surface: 1.4mm (Mechanical Surface Detection)
- Electronics: DAE4 Sn1207; Calibrated: 2021/11/22
- Phantom: SAM with left table; Type: SAM;
- Measurement SW: DASY52, Version 52.10 (0); SEMCAD X Version 14.6.10 (7417)

Configuration/2600MHz Body/Area Scan (9x9x1): Measurement grid: dx=12mm, dy=12mm

Maximum value of SAR (measured) = 15.6 W/kg

Configuration/2600MHz Body/Zoom Scan (7x7x7)/Cube 0: Measurement grid: dx=5mm, dy=5mm, dz=5mm

Reference Value = 119.4 V/m; Power Drift = -0.03 dB

Peak SAR (extrapolated) = 31.9 W/kg

SAR(1 g) = 14.6 W/kg; SAR(10 g) = 6.49 W/kg

Maximum value of SAR (measured) = 25.6 W/kg

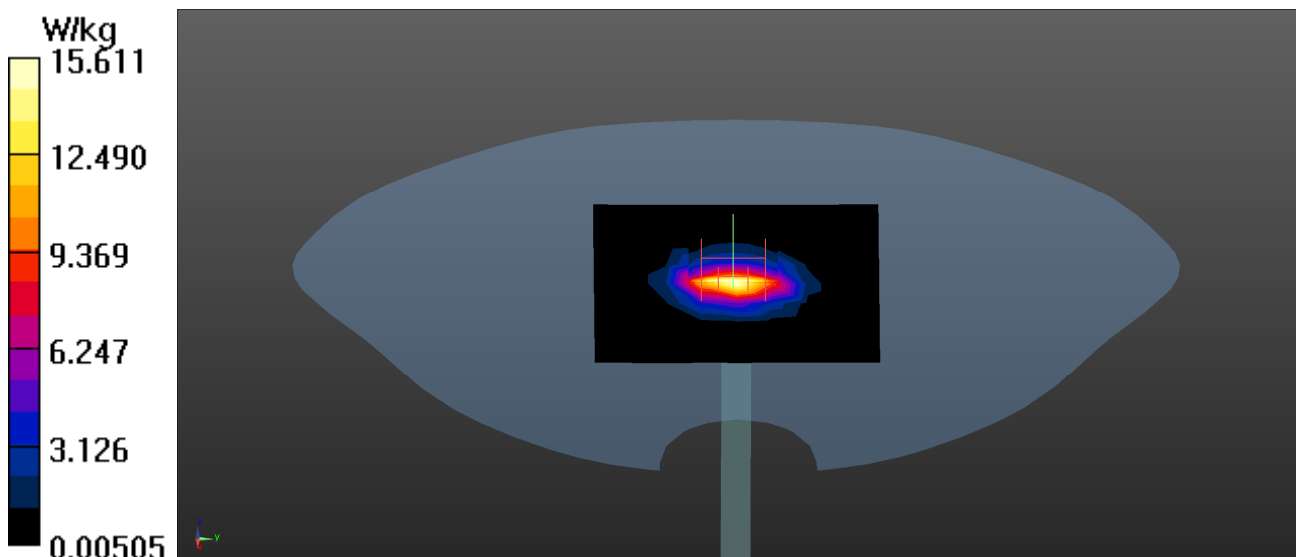

Test Laboratory: DEKRA

Date: 2022/02/17

System Performance Check_5250MHz-Head

DUT: Dipole 5GHz; Type: D5GHzV2

Communication System: UID 0, CW; Frequency: 5250 MHz;

Communication System PAR: 0 dB

Medium parameters used: $f = 5250$ MHz; $\sigma = 4.64$ S/m; $\epsilon_r = 35.45$; $\rho = 1000$ kg/m³

Phantom section: Flat Section

Ambient Temperature (°C) : 22.8, Liquid Temperature (°C) : 21.2

Measurement Standard: DASYS (IEEE/IEC/ANSI C63.19-2011)

DASY5 Configuration:

- Probe: EX3DV4 - SN3698; ConvF(4.7, 4.7, 4.7); Calibrated: 2021/11/24;
- Sensor-Surface: 1.4mm (Mechanical Surface Detection)
- Electronics: DAE4 Sn1207; Calibrated: 2021/11/22
- Phantom: SAM with left table; Type: SAM;
- Measurement SW: DASYS2, Version 52.10 (0); SEMCAD X Version 14.6.10 (7417)

Configuration/5250MHz-Head/Area Scan (8x8x1): Measurement grid: dx=10mm, dy=10mm

Maximum value of SAR (measured) = 17.4 W/kg

Configuration/5250MHz-Head/Zoom Scan (7x7x7)/Cube 0: Measurement grid: dx=4mm, dy=4mm, dz=1.4mm

Reference Value = 78.94 V/m; Power Drift = 0.14 dB

Peak SAR (extrapolated) = 30.8 W/kg

SAR(1 g) = 8.48 W/kg; SAR(10 g) = 2.36 W/kg

Maximum value of SAR (measured) = 25.3 W/kg

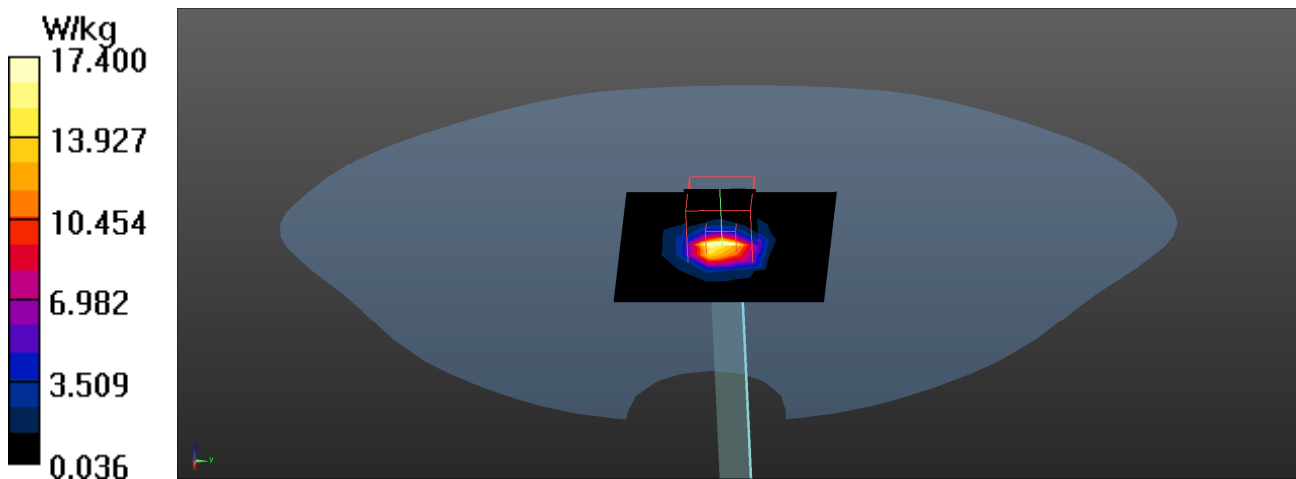

Test Laboratory: DEKRA

Date: 2022/03/11

System Performance Check_5250MHz-Head**DUT: Dipole 5GHz; Type: D5GHzV2**

Communication System: UID 0, CW; Frequency: 5250 MHz;

Communication System PAR: 0 dB

Medium parameters used: $f = 5250$ MHz; $\sigma = 4.78$ S/m; $\epsilon_r = 36.53$; $\rho = 1000$ kg/m³

Phantom section: Flat Section

Ambient Temperature (°C) : 22.9, Liquid Temperature (°C) : 21.9

Measurement Standard: DASYS (IEEE/IEC/ANSI C63.19-2011)

DASY5 Configuration:

- Probe: EX3DV4 - SN3698; ConvF(4.7, 4.7, 4.7); Calibrated: 2021/11/24;
- Sensor-Surface: 1.4mm (Mechanical Surface Detection)
- Electronics: DAE4 Sn1207; Calibrated: 2021/11/22
- Phantom: SAM with left table; Type: SAM;
- Measurement SW: DASYS2, Version 52.10 (0); SEMCAD X Version 14.6.10 (7417)

Configuration/5250MHz-Head/Area Scan (8x8x1): Measurement grid: dx=10mm, dy=10mm

Maximum value of SAR (measured) = 16.2 W/kg

Configuration/5250MHz-Head/Zoom Scan (7x7x7)/Cube 0: Measurement grid: dx=4mm, dy=4mm, dz=1.4mm

Reference Value = 79.16 V/m; Power Drift = 0.11 dB

Peak SAR (extrapolated) = 31.22 W/kg

SAR(1 g) = 8.81 W/kg; SAR(10 g) = 2.46 W/kg

Maximum value of SAR (measured) = 25.3 W/kg

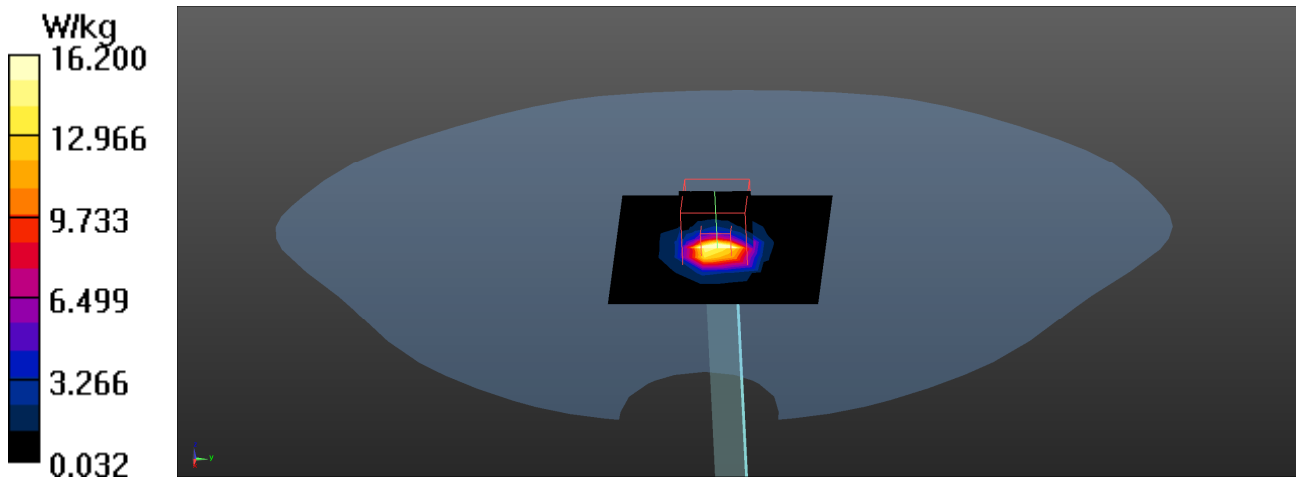

Test Laboratory: DEKRA

Date: 2022/02/17

System Performance Check_5600MHz-Head**DUT: Dipole 5GHz; Type: D5GHzV2**

Communication System: UID 0, CW; Frequency: 5600 MHz;

Communication System PAR: 0 dB

Medium parameters used: $f = 5600$ MHz; $\sigma = 5.12$ S/m; $\epsilon_r = 34.48$; $\rho = 1000$ kg/m³

Phantom section: Flat Section

Ambient Temperature (°C) : 22.8, Liquid Temperature (°C) : 21.2

Measurement Standard: DASYS (IEEE/IEC/ANSI C63.19-2011)

DASY5 Configuration:

- Probe: EX3DV4 - SN3698; ConvF(4.35, 4.35, 4.35); Calibrated: 2021/11/24;
- Sensor-Surface: 1.4mm (Mechanical Surface Detection)
- Electronics: DAE4 Sn1207; Calibrated: 2021/11/22
- Phantom: SAM with left table; Type: SAM;
- Measurement SW: DASYS2, Version 52.10 (0); SEMCAD X Version 14.6.10 (7417)

Configuration/5600MHz-Head/Area Scan (8x8x1): Measurement grid: dx=10mm, dy=10mm

Maximum value of SAR (measured) = 20.2 W/kg

Configuration/5600MHz-Head/Zoom Scan (7x7x7)/Cube 0: Measurement grid: dx=4mm, dy=4mm, dz=1.4mm

Reference Value = 81.69 V/m; Power Drift = -0.16 dB

Peak SAR (extrapolated) = 36.7 W/kg

SAR(1 g) = 8.42 W/kg; SAR(10 g) = 2.48 W/kg

Maximum value of SAR (measured) = 27.1 W/kg

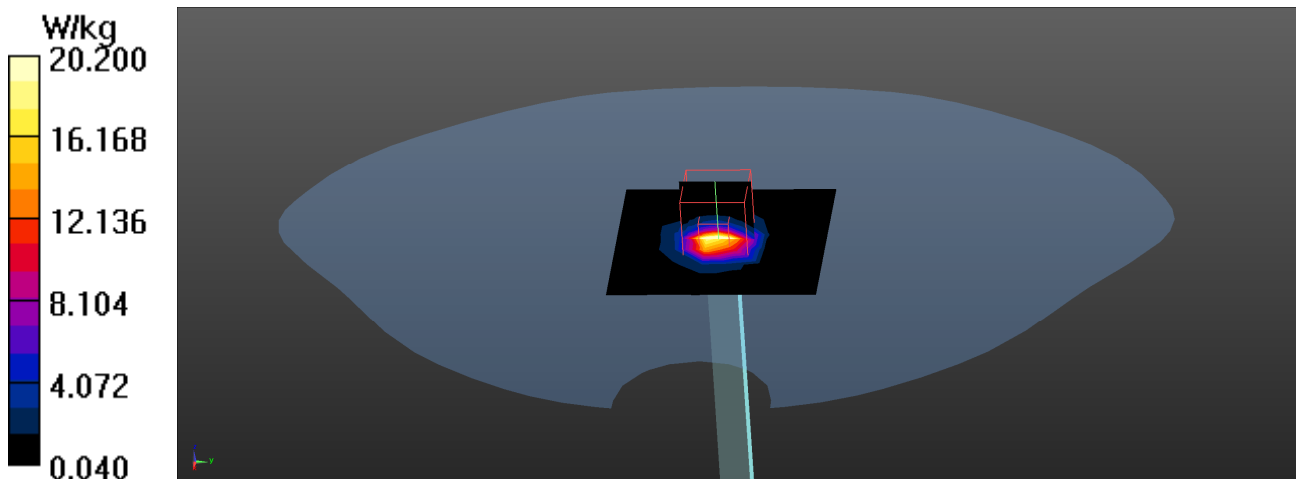

Test Laboratory: DEKRA

Date: 2022/03/11

System Performance Check_5600MHz-Head**DUT: Dipole 5GHz; Type: D5GHzV2**

Communication System: UID 0, CW; Frequency: 5600 MHz;

Communication System PAR: 0 dB

Medium parameters used: $f = 5600$ MHz; $\sigma = 5.26$ S/m; $\epsilon_r = 35.56$; $\rho = 1000$ kg/m³

Phantom section: Flat Section

Ambient Temperature (°C) : 22.9, Liquid Temperature (°C) : 21.9

Measurement Standard: DASYS (IEEE/IEC/ANSI C63.19-2011)

DASY5 Configuration:

- Probe: EX3DV4 - SN3698; ConvF(4.35, 4.35, 4.35); Calibrated: 2021/11/24;
- Sensor-Surface: 1.4mm (Mechanical Surface Detection)
- Electronics: DAE4 Sn1207; Calibrated: 2021/11/22
- Phantom: SAM with left table; Type: SAM;
- Measurement SW: DASYS2, Version 52.10 (0); SEMCAD X Version 14.6.10 (7417)

Configuration/5600MHz-Head/Area Scan (8x8x1): Measurement grid: dx=10mm, dy=10mm

Maximum value of SAR (measured) = 18.7 W/kg

Configuration/5600MHz-Head/Zoom Scan (7x7x7)/Cube 0: Measurement grid: dx=4mm, dy=4mm, dz=1.4mm

Reference Value = 80.44 V/m; Power Drift = 0.17 dB

Peak SAR (extrapolated) = 36.1 W/kg

SAR(1 g) = 9.28 W/kg; SAR(10 g) = 2.47 W/kg

Maximum value of SAR (measured) = 28.2 W/kg

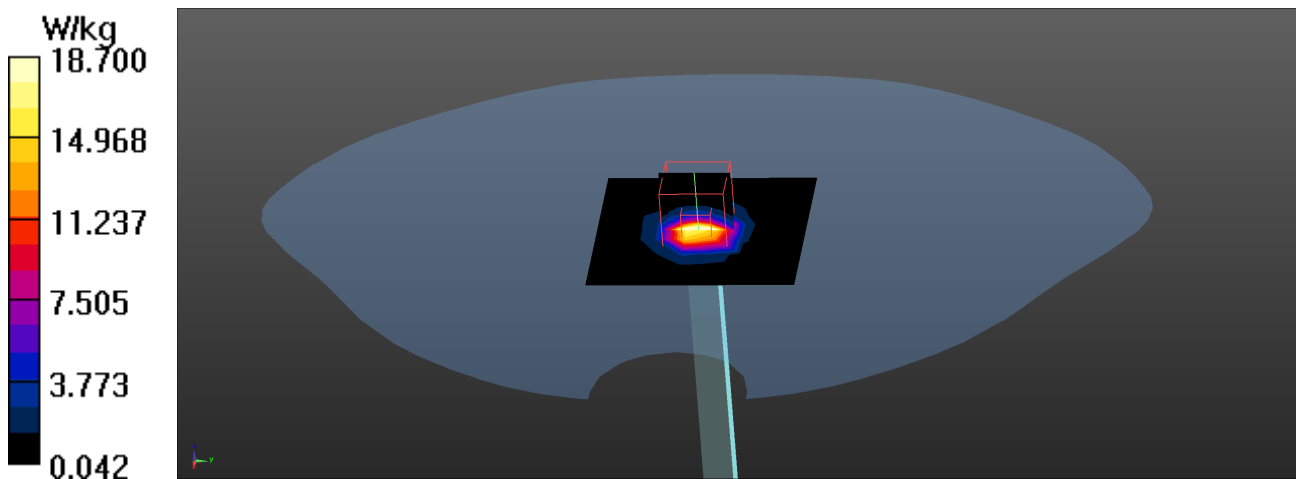

Test Laboratory: DEKRA

Date: 2022/02/17

System Performance Check_5800MHz-Head**DUT: Dipole 5GHz; Type: D5GHzV2**

Communication System: UID 0, CW; Frequency: 5800 MHz;

Communication System PAR: 0 dB

Medium parameters used: $f = 5800$ MHz; $\sigma = 5.38$ S/m; $\epsilon_r = 33.93$; $\rho = 1000$ kg/m³

Phantom section: Flat Section

Ambient Temperature (°C) : 22.8, Liquid Temperature (°C) : 21.2

Measurement Standard: DASY5 (IEEE/IEC/ANSI C63.19-2011)

DASY5 Configuration:

- Probe: EX3DV4 - SN3698; ConvF(4.58, 4.58, 4.58); Calibrated: 2021/11/24;
- Sensor-Surface: 1.4mm (Mechanical Surface Detection)
- Electronics: DAE4 Sn1207; Calibrated: 2021/11/22
- Phantom: SAM with left table; Type: SAM;
- Measurement SW: DASY52, Version 52.10 (0); SEMCAD X Version 14.6.10 (7417)

Configuration/5800MHz-Head/Area Scan (8x8x1): Measurement grid: dx=10mm, dy=10mm

Maximum value of SAR (measured) = 15.9 W/kg

Configuration/5800MHz-Head/Zoom Scan (7x7x7)/Cube 0: Measurement grid: dx=4mm, dy=4mm, dz=1.4mm

Reference Value = 74.17 V/m; Power Drift = 0.18 dB

Peak SAR (extrapolated) = 36.3 W/kg

SAR(1 g) = 8.53 W/kg; SAR(10 g) = 2.47 W/kg

Maximum value of SAR (measured) = 25.0 W/kg

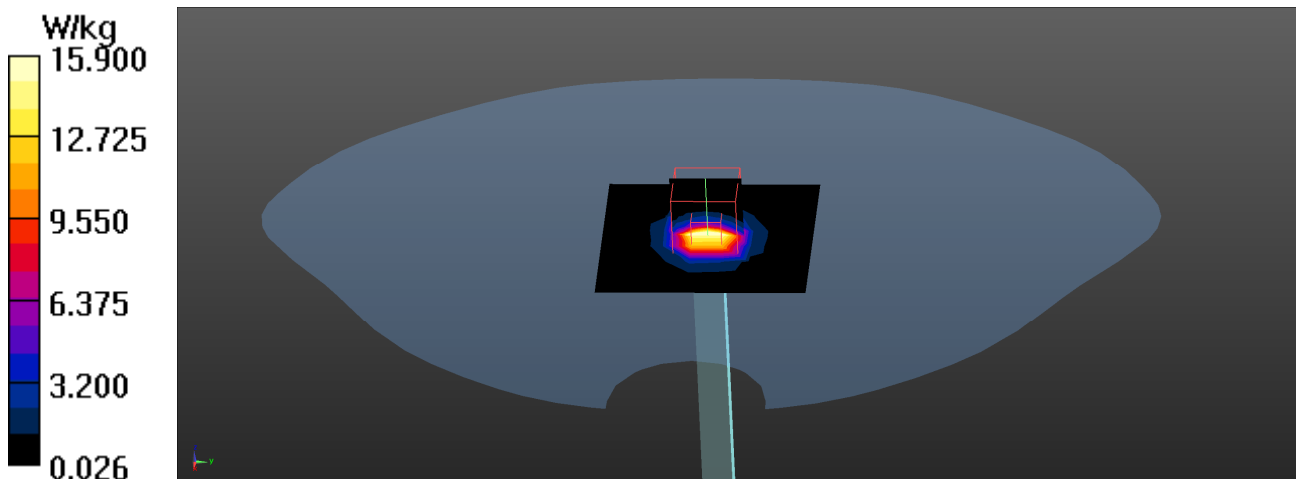

Test Laboratory: DEKRA

Date: 2022/03/11

System Performance Check_5800MHz-Head**DUT: Dipole 5GHz; Type: D5GHzV2**

Communication System: UID 0, CW; Frequency: 5800 MHz;

Communication System PAR: 0 dB

Medium parameters used: $f = 5800$ MHz; $\sigma = 5.51$ S/m; $\epsilon_r = 35.01$; $\rho = 1000$ kg/m³

Phantom section: Flat Section

Ambient Temperature (°C) : 22.9, Liquid Temperature (°C) : 21.9

Measurement Standard: DASYS (IEEE/IEC/ANSI C63.19-2011)

DASY5 Configuration:

- Probe: EX3DV4 - SN3698; ConvF(4.58, 4.58, 4.58); Calibrated: 2021/11/24;
- Sensor-Surface: 1.4mm (Mechanical Surface Detection)
- Electronics: DAE4 Sn1207; Calibrated: 2021/11/22
- Phantom: SAM with left table; Type: SAM;
- Measurement SW: DASYS2, Version 52.10 (0); SEMCAD X Version 14.6.10 (7417)

Configuration/5800MHz-Head/Area Scan (8x8x1): Measurement grid: dx=10mm, dy=10mm

Maximum value of SAR (measured) = 17.0 W/kg

Configuration/5800MHz-Head/Zoom Scan (7x7x7)/Cube 0: Measurement grid: dx=4mm, dy=4mm, dz=1.4mm

Reference Value = 75.06 V/m; Power Drift = 0.11 dB

Peak SAR (extrapolated) = 36.3 W/kg

SAR(1 g) = 8.72 W/kg; SAR(10 g) = 2.36 W/kg

Maximum value of SAR (measured) = 25.7 W/kg

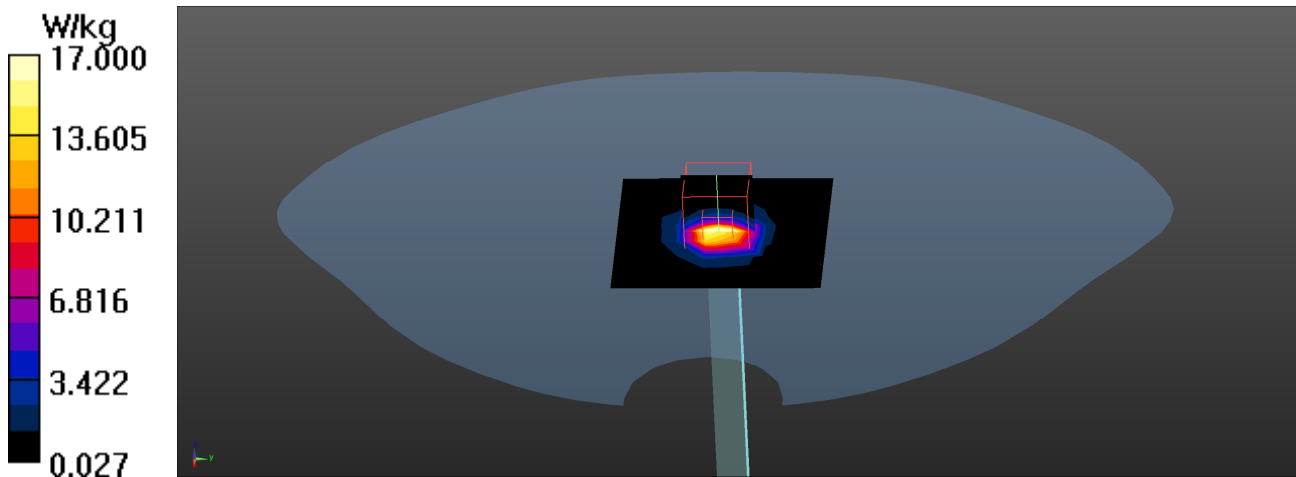

Appendix B. SAR measurement Data

Test Laboratory: DEKRA

Date: 2022/02/16

01_802.11b_1-Bottom-Aux-Speed

DUT: 7c Modular Platform; Type: QSIP7180

Communication System: UID 0, WLAN 2.4G; Frequency: 2412 MHz;

Communication System PAR: 0 dB

Medium parameters used: $f = 2412$ MHz; $\sigma = 1.81$ S/m; $\epsilon_r = 39.81$; $\rho = 1000$ kg/m³

Phantom section: Flat Section

Ambient Temperature (°C) : 22.4, Liquid Temperature (°C) : 21.7

Measurement Standard: DASY5 (IEEE/IEC/ANSI C63.19-2011)

DASY5 Configuration:

- Probe: EX3DV4 - SN3698; ConvF(7.19, 7.19, 7.19); Calibrated: 2021/11/24;
- Sensor-Surface: 1.4mm (Mechanical Surface Detection)
- Electronics: DAE4 Sn1207; Calibrated: 2021/11/22
- Phantom: SAM with left table; Type: SAM;
- Measurement SW: DASY52, Version 52.10 (0); SEMCAD X Version 14.6.10 (7417)

Configuration/Flat/Area Scan (7x11x1): Measurement grid: dx=12mm, dy=12mm

Maximum value of SAR (measured) = 0.0176 W/kg

Configuration/Flat/Zoom Scan (7x7x7)/Cube 0: Measurement grid: dx=5mm, dy=5mm, dz=5mm

Reference Value = 1.358 V/m; Power Drift = -0.19 dB

Peak SAR (extrapolated) = 0.0240 W/kg

SAR(1 g) = 0.016 W/kg; SAR(10 g) = 0.011 W/kg

Maximum value of SAR (measured) = 0.0181 W/kg

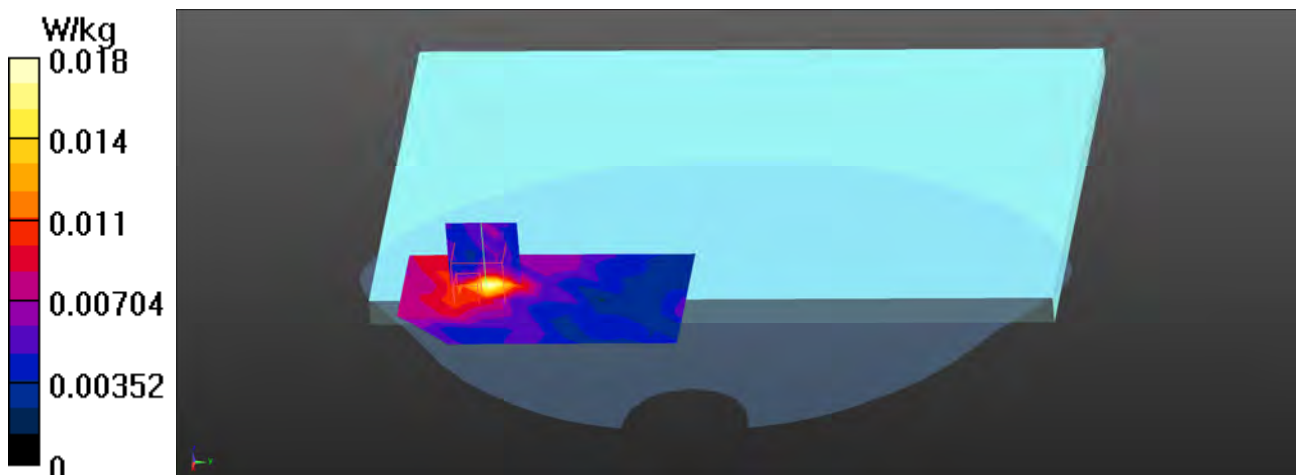

Test Laboratory: DEKRA

Date: 2022/02/16

02_BT_1M_39-Bottom-Aux-Speed**DUT: 7c Modular Platform; Type: QSIP7180**

Communication System: UID 0, BT 1M&3M&BLE; Frequency: 2441 MHz;

Communication System PAR: 0 dB

Medium parameters used: $f = 2441$ MHz; $\sigma = 1.83$ S/m; $\epsilon_r = 39.71$; $\rho = 1000$ kg/m³

Phantom section: Flat Section

Ambient Temperature (°C) : 22.4, Liquid Temperature (°C) : 21.7

Measurement Standard: DASY5 (IEEE/IEC/ANSI C63.19-2011)

DASY5 Configuration:

- Probe: EX3DV4 - SN3698; ConvF(7.19, 7.19, 7.19); Calibrated: 2021/11/24;
- Sensor-Surface: 1.4mm (Mechanical Surface Detection)
- Electronics: DAE4 Sn1207; Calibrated: 2021/11/22
- Phantom: SAM with left table; Type: SAM;
- Measurement SW: DASY52, Version 52.10 (0); SEMCAD X Version 14.6.10 (7417)

Configuration/Flat/Area Scan (8x13x1): Measurement grid: dx=12mm, dy=12mm
Maximum value of SAR (measured) = 0.00804 W/kg

Configuration/Flat/Zoom Scan (7x7x7)/Cube 0: Measurement grid: dx=5mm, dy=5mm, dz=5mm

Reference Value = 1.569 V/m; Power Drift = 0.16 dB

Peak SAR (extrapolated) = 0.0120 W/kg

SAR(1 g) = 0.010 W/kg; SAR(10 g) = 0.00905 W/kg

Maximum value of SAR (measured) = 0.0123 W/kg

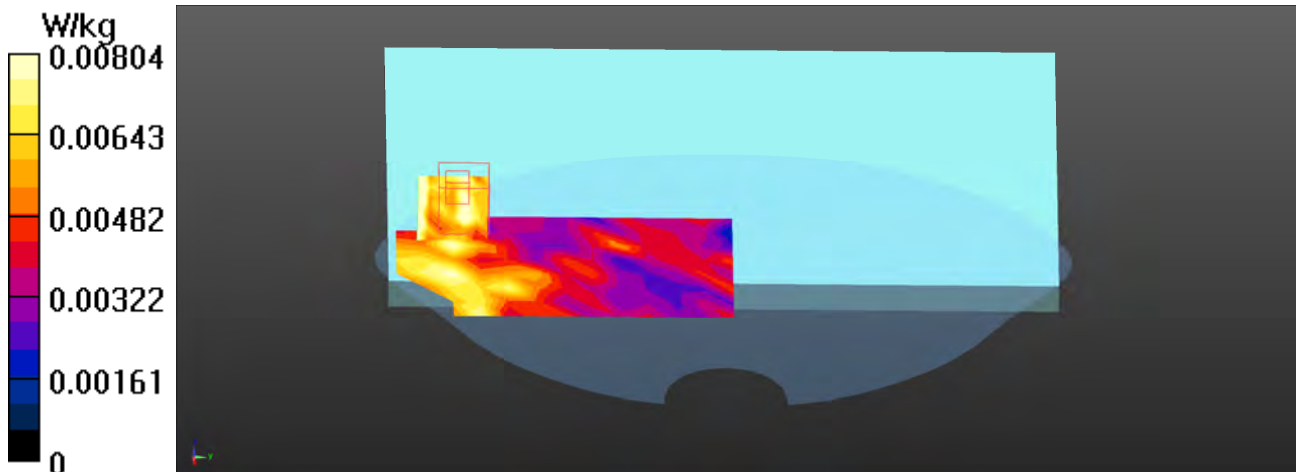

802.11b EUT Bottom (Aux-Speed) Z-Axis plot

Channel: 1

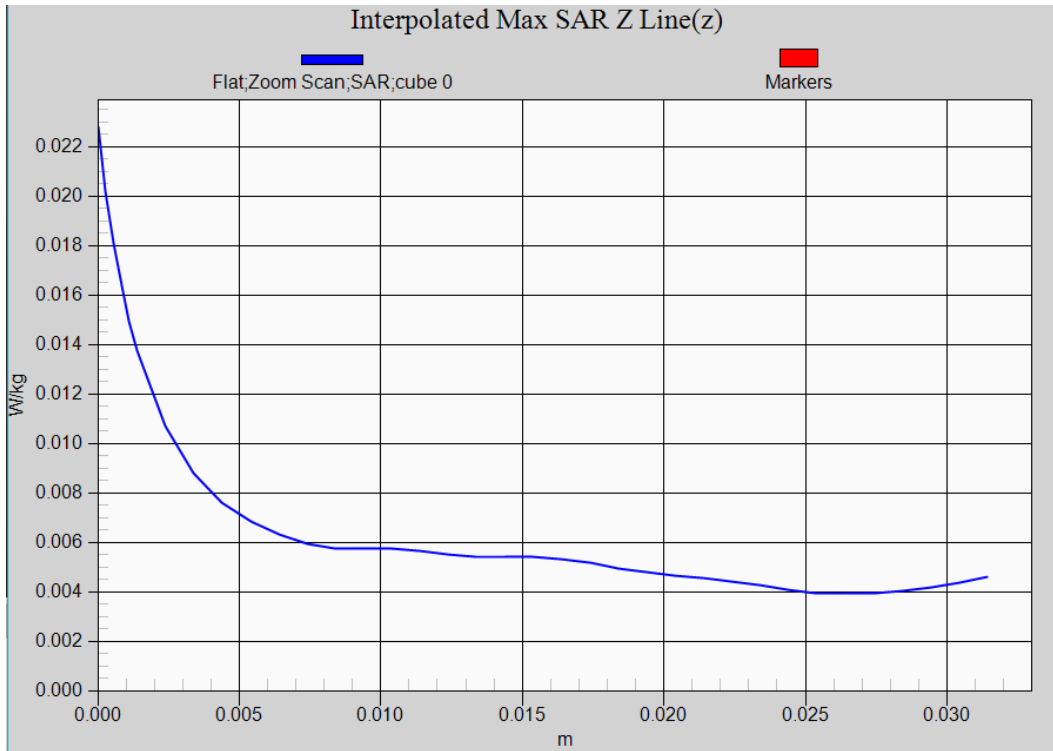

Test Laboratory: DEKRA

Date: 2022/02/17

03_802.11ac80M_122-Bottom-Main-Speed**DUT: 7c Modular Platform; Type: QSIP7180**

Communication System: UID 0, WLAN 5G; Frequency: 5610 MHz;

Communication System PAR: 0 dB

Medium parameters used: $f = 5610$ MHz; $\sigma = 5.13$ S/m; $\epsilon_r = 34.46$; $\rho = 1000$ kg/m³

Phantom section: Flat Section

Ambient Temperature (°C) : 22.8, Liquid Temperature (°C) : 21.2

Measurement Standard: DASY5 (IEEE/IEC/ANSI C63.19-2011)

DASY5 Configuration:

- Probe: EX3DV4 - SN3698; ConvF(4.35, 4.35, 4.35); Calibrated: 2021/11/24;
- Sensor-Surface: 1.4mm (Mechanical Surface Detection)
- Electronics: DAE4 Sn1207; Calibrated: 2021/11/22
- Phantom: SAM with right table; Type: SAM;
- Measurement SW: DASY52, Version 52.10 (0); SEMCAD X Version 14.6.10 (7417)

Configuration/Flat/Area Scan (9x15x1): Measurement grid: dx=10mm, dy=10mm

Maximum value of SAR (measured) = 0.120 W/kg

Configuration/Flat/Zoom Scan (7x7x7)/Cube 0: Measurement grid: dx=4mm, dy=4mm, dz=1.4mm

Reference Value = 1.902 V/m; Power Drift = 0.13 dB

Peak SAR (extrapolated) = 0.219 W/kg

SAR(1 g) = 0.064 W/kg; SAR(10 g) = 0.038 W/kg

Maximum value of SAR (measured) = 0.127 W/kg

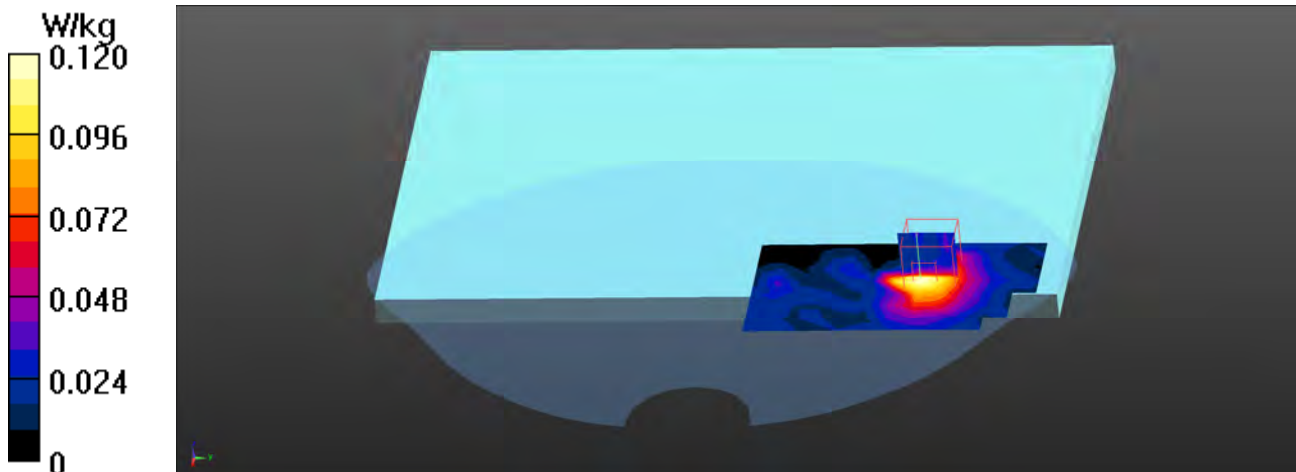

Test Laboratory: DEKRA

Date: 2022/02/17

04_802.11n40M_54-Bottom-Aux-Speed**DUT: 7c Modular Platform; Type: QSIP7180**

Communication System: UID 0, WLAN 5G; Frequency: 5270 MHz;

Communication System PAR: 0 dB

Medium parameters used: $f = 5270$ MHz; $\sigma = 4.67$ S/m; $\epsilon_r = 35.41$; $\rho = 1000$ kg/m³

Phantom section: Flat Section

Ambient Temperature (°C) : 22.8, Liquid Temperature (°C) : 21.2

Measurement Standard: DASY5 (IEEE/IEC/ANSI C63.19-2011)

DASY5 Configuration:

- Probe: EX3DV4 - SN3698; ConvF(4.7, 4.7, 4.7); Calibrated: 2021/11/24;
- Sensor-Surface: 1.4mm (Mechanical Surface Detection)
- Electronics: DAE4 Sn1207; Calibrated: 2021/11/22
- Phantom: SAM with right table; Type: SAM;
- Measurement SW: DASY52, Version 52.10 (0); SEMCAD X Version 14.6.10 (7417)

Configuration/Flat/Area Scan (9x15x1): Measurement grid: dx=10mm, dy=10mm

Maximum value of SAR (measured) = 0.0583 W/kg

Configuration/Flat/Zoom Scan (7x7x7)/Cube 0: Measurement grid: dx=4mm, dy=4mm, dz=1.4mm

Reference Value = 1.388 V/m; Power Drift = 0.17 dB

Peak SAR (extrapolated) = 0.143 W/kg

SAR(1 g) = 0.036 W/kg; SAR(10 g) = 0.022 W/kg

Maximum value of SAR (measured) = 0.0715 W/kg

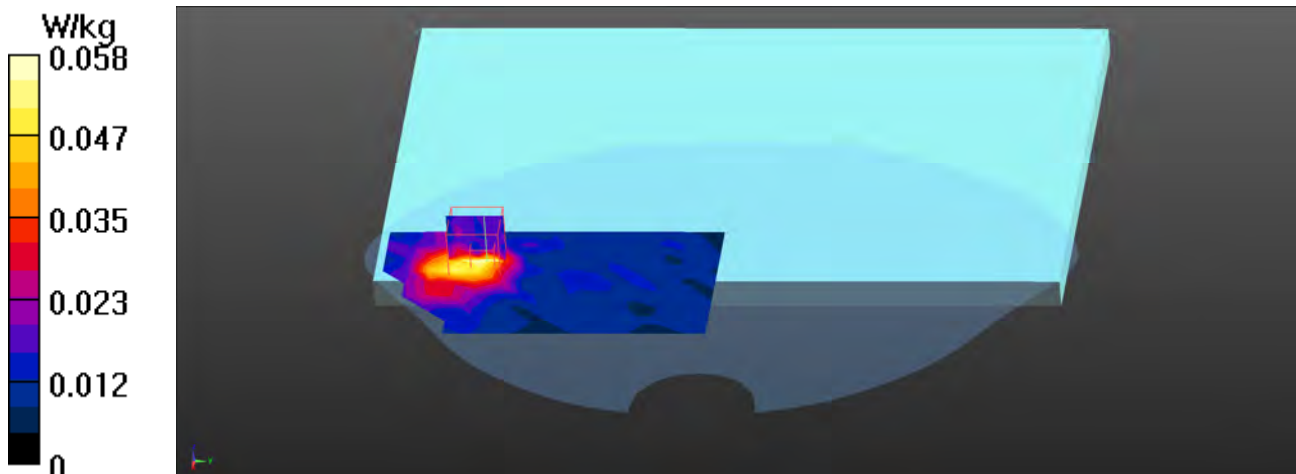

Test Laboratory: DEKRA

Date: 2022/02/17

05_802.11ac80M_155-Bottom-Aux-Speed**DUT: 7c Modular Platform; Type: QSIP7180**

Communication System: UID 0, WLAN 5G; Frequency: 5775 MHz;

Communication System PAR: 0 dB

Medium parameters used: $f = 5775$ MHz; $\sigma = 5.35$ S/m; $\epsilon_r = 34.01$; $\rho = 1000$ kg/m³

Phantom section: Flat Section

Ambient Temperature (°C) : 22.8, Liquid Temperature (°C) : 21.2

Measurement Standard: DASY5 (IEEE/IEC/ANSI C63.19-2011)

DASY5 Configuration:

- Probe: EX3DV4 - SN3698; ConvF(4.58, 4.58, 4.58); Calibrated: 2021/11/24;
- Sensor-Surface: 1.4mm (Mechanical Surface Detection)
- Electronics: DAE4 Sn1207; Calibrated: 2021/11/22
- Phantom: SAM with right table; Type: SAM;
- Measurement SW: DASY52, Version 52.10 (0); SEMCAD X Version 14.6.10 (7417)

Configuration/Flat/Area Scan (9x15x1): Measurement grid: dx=10mm, dy=10mm

Maximum value of SAR (measured) = 0.0829 W/kg

Configuration/Flat/Zoom Scan (7x7x7)/Cube 0: Measurement grid: dx=4mm, dy=4mm, dz=1.4mm

Reference Value = 1.723 V/m; Power Drift = 0.11 dB

Peak SAR (extrapolated) = 0.224 W/kg

SAR(1 g) = 0.048 W/kg; SAR(10 g) = 0.029 W/kg

Maximum value of SAR (measured) = 0.0923 W/kg

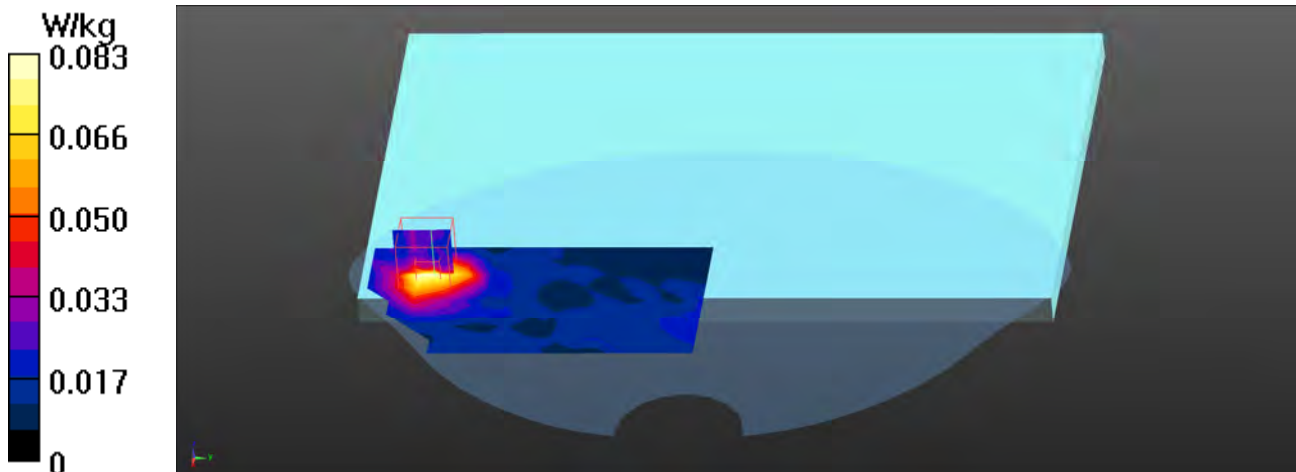

802.11ac80 EUT Bottom (Main-Speed), Z-Axis plot

Channel: 122

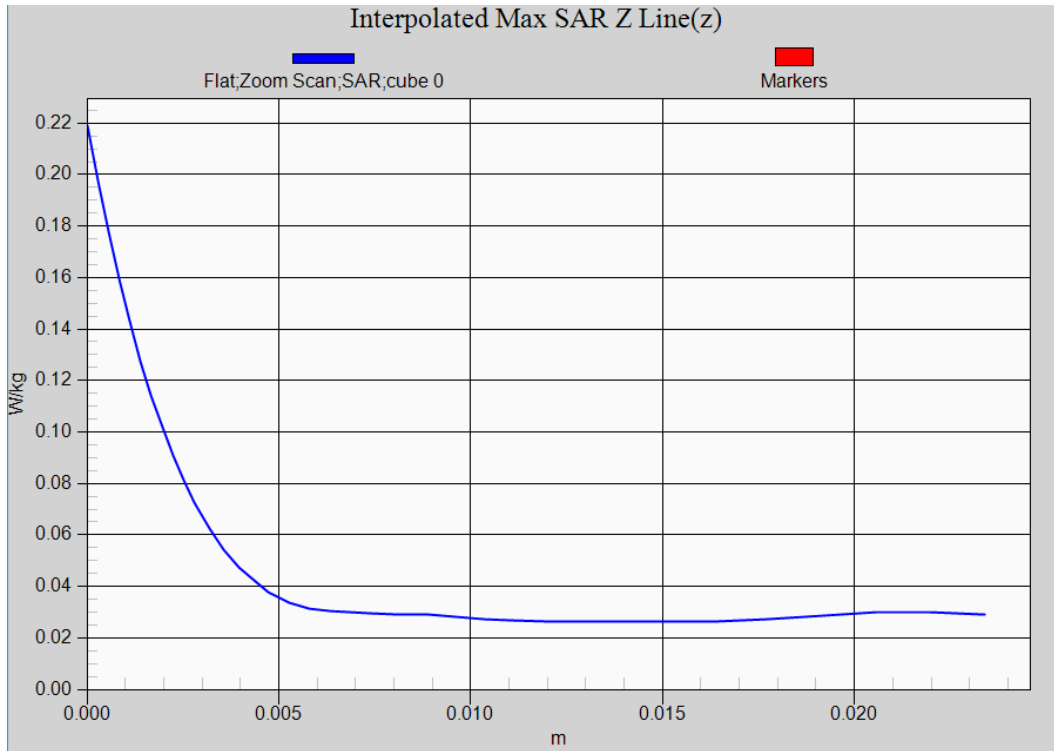

Test Laboratory: DEKRA

Date: 2022/02/23

06_WCDMA_BAND 2_RMC_Bottom_9538-Speed_0mm**DUT: 7c Modular Platform; Type: QSIP7180**

Communication System: UID 0, FCC WCDMA_Band-2; Frequency: 1907.6 MHz;

Communication System PAR: 0 dB

Medium parameters used: $f = 1907.6$ MHz; $\sigma = 1.39$ S/m; $\epsilon_r = 39.91$; $\rho = 1000$ kg/m³

Phantom section: Flat Section

Ambient Temperature (°C) : 23.1, Liquid Temperature (°C) : 22.4

Measurement Standard: DASY5 (IEEE/IEC/ANSI C63.19-2011)

DASY5 Configuration:

- Probe: EX3DV4 - SN3698; ConvF(7.6, 7.6, 7.6); Calibrated: 2021/11/24;
- Sensor-Surface: 1.4mm (Mechanical Surface Detection)
- Electronics: DAE4 Sn1207; Calibrated: 2021/11/22
- Phantom: SAM with left table; Type: SAM;
- Measurement SW: DASY52, Version 52.10 (0); SEMCAD X Version 14.6.10 (7417)

Configuration/Flat/Area Scan (9x9x1): Measurement grid: dx=15mm, dy=15mm

Maximum value of SAR (measured) = 0.877 W/kg

Configuration/Flat/Zoom Scan (5x5x7)/Cube 0: Measurement grid: dx=8mm, dy=8mm, dz=5mm

Reference Value = 16.12 V/m; Power Drift = 0.05 dB

Peak SAR (extrapolated) = 1.15 W/kg

SAR(1 g) = 0.616 W/kg; SAR(10 g) = 0.336 W/kg

Maximum value of SAR (measured) = 0.913 W/kg

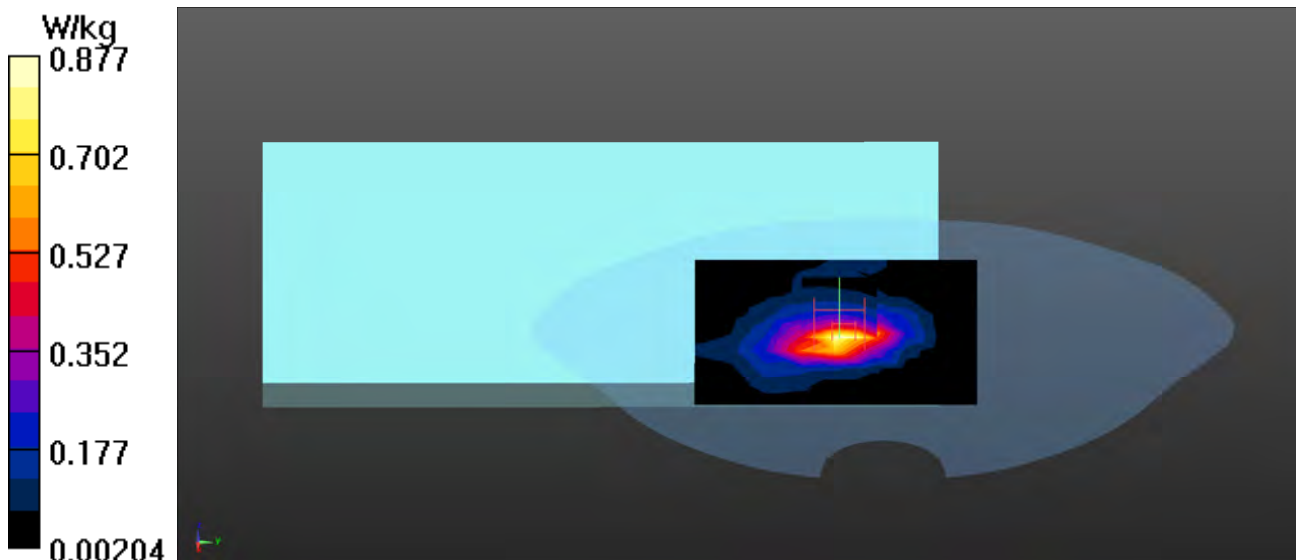

WCDMA Band 2 RMC Bottom (Speed 0mm) Z-Axis plot

Channel: 9538

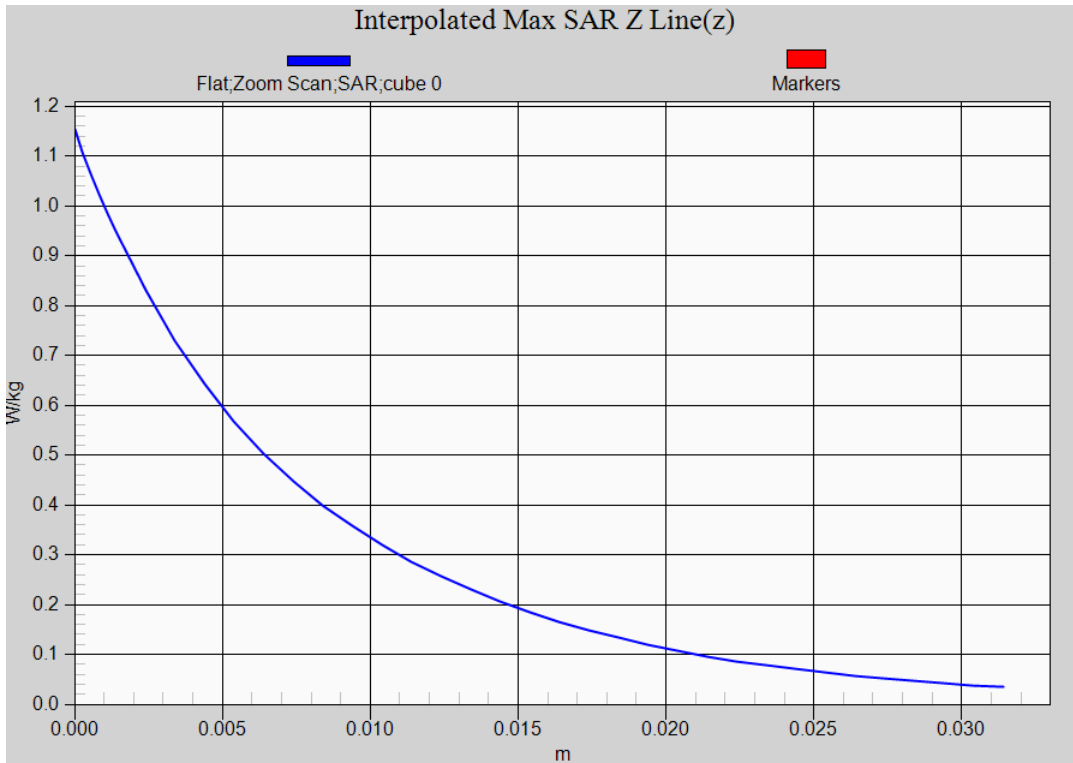

Test Laboratory: DEKRA

Date: 2022/02/22

07_WCDMA_BAND 5_RMC_Bottom_4132-Speed_0mm**DUT: 7c Modular Platform; Type: QSIP7180**

Communication System: UID 0, FCC WCDMA_Band-5; Frequency: 826.4 MHz;

Communication System PAR: 0 dB

Medium parameters used: $f = 826.4$ MHz; $\sigma = 0.89$ S/m; $\epsilon_r = 41.48$; $\rho = 1000$ kg/m³

Phantom section: Flat Section

Ambient Temperature (°C) : 23.2, Liquid Temperature (°C) : 22.1

Measurement Standard: DASY5 (IEEE/IEC/ANSI C63.19-2011)

DASY5 Configuration:

- Probe: EX3DV4 - SN3698; ConvF(8.9, 8.9, 8.9); Calibrated: 2021/11/24;
- Sensor-Surface: 1.4mm (Mechanical Surface Detection)
- Electronics: DAE4 Sn1207; Calibrated: 2021/11/22
- Phantom: SAM with left table; Type: SAM;
- Measurement SW: DASY52, Version 52.10 (0); SEMCAD X Version 14.6.10 (7417)

Configuration/Flat/Area Scan (9x10x1): Measurement grid: dx=15mm, dy=15mm

Maximum value of SAR (measured) = 0.906 W/kg

Configuration/Flat/Zoom Scan (5x5x7)/Cube 0: Measurement grid: dx=8mm, dy=8mm, dz=5mm

Reference Value = 28.29 V/m; Power Drift = 0.08 dB

Peak SAR (extrapolated) = 1.10 W/kg

SAR(1 g) = 0.685 W/kg; SAR(10 g) = 0.430 W/kg

Maximum value of SAR (measured) = 0.946 W/kg

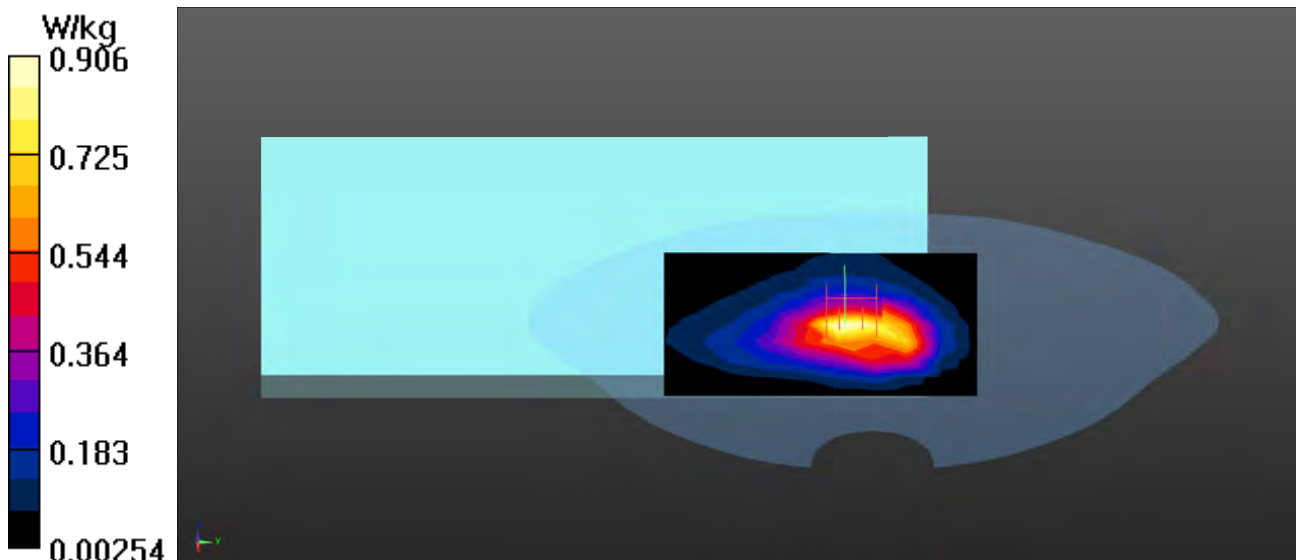

WCDMA Band 5 RMC Bottom (Speed 0mm) Z-Axis plot

Channel: 4132

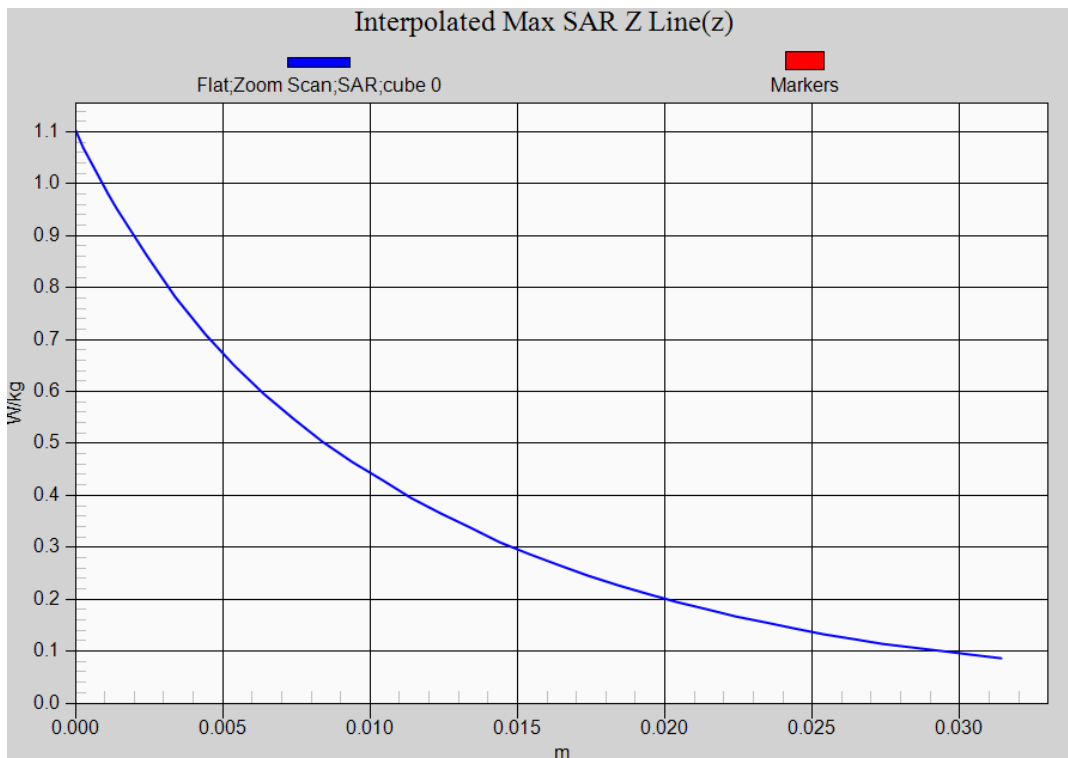

Test Laboratory: DEKRA

Date: 2022/02/23

08_LTE_Band2_QPSK_20M_18700_1RB-0_Bottom-Speed_0mm**DUT: 7c Modular Platform; Type: QSIP7180**

Communication System: UID 0, LTE Band2; Frequency: 1860 MHz;

Communication System PAR: 0 dB

Medium parameters used: $f = 1860$ MHz; $\sigma = 1.37$ S/m; $\epsilon_r = 40.38$; $\rho = 1000$ kg/m³

Phantom section: Flat Section

Ambient Temperature (°C) : 23.1, Liquid Temperature (°C) : 22.4

Measurement Standard: DASYS (IEEE/IEC/ANSI C63.19-2011)

DASY5 Configuration:

- Probe: EX3DV4 - SN3698; ConvF(7.6, 7.6, 7.6); Calibrated: 2021/11/24;
- Sensor-Surface: 1.4mm (Mechanical Surface Detection)
- Electronics: DAE4 Sn1207; Calibrated: 2021/11/22
- Phantom: SAM with left table; Type: SAM;
- Measurement SW: DASYS2, Version 52.10 (0); SEMCAD X Version 14.6.10 (7417)

Configuration/Flat/Area Scan (9x10x1): Measurement grid: dx=15mm, dy=15mm

Maximum value of SAR (measured) = 0.802 W/kg

Configuration/Flat/Zoom Scan (5x5x7)/Cube 0: Measurement grid: dx=8mm, dy=8mm, dz=5mm

Reference Value = 12.15 V/m; Power Drift = 0.06 dB

Peak SAR (extrapolated) = 1.05 W/kg

SAR(1 g) = 0.573 W/kg; SAR(10 g) = 0.318 W/kg

Maximum value of SAR (measured) = 0.864 W/kg

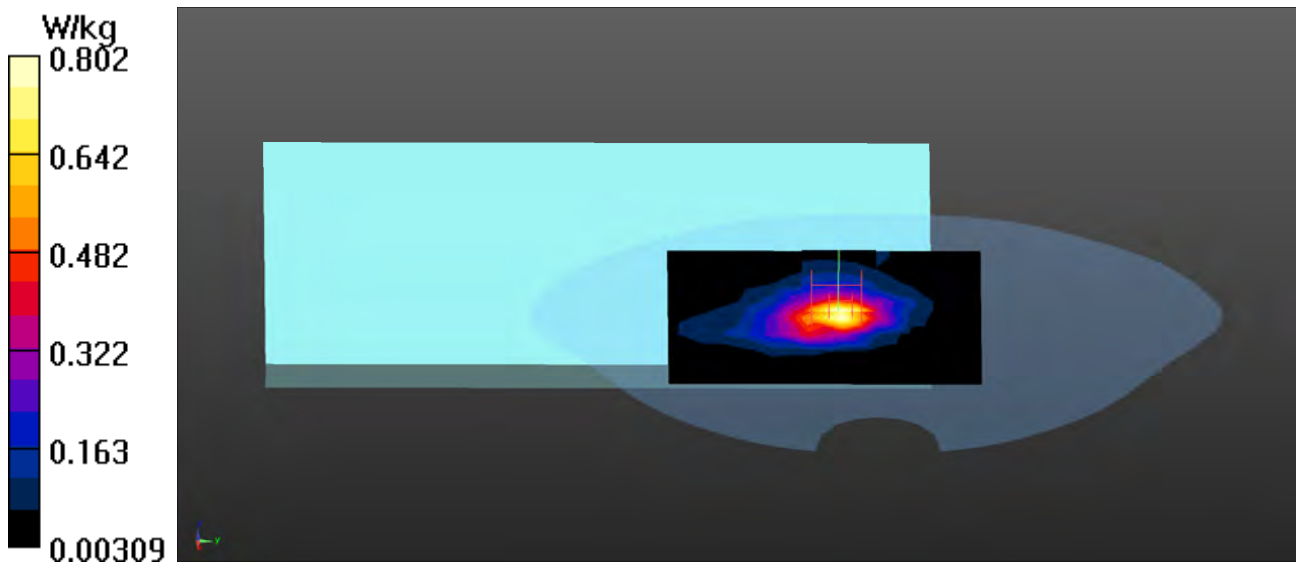

LTE Band 2 20M QPSK 1RB-0 Bottom (Speed 0mm) Z-Axis plot

Channel: 18700

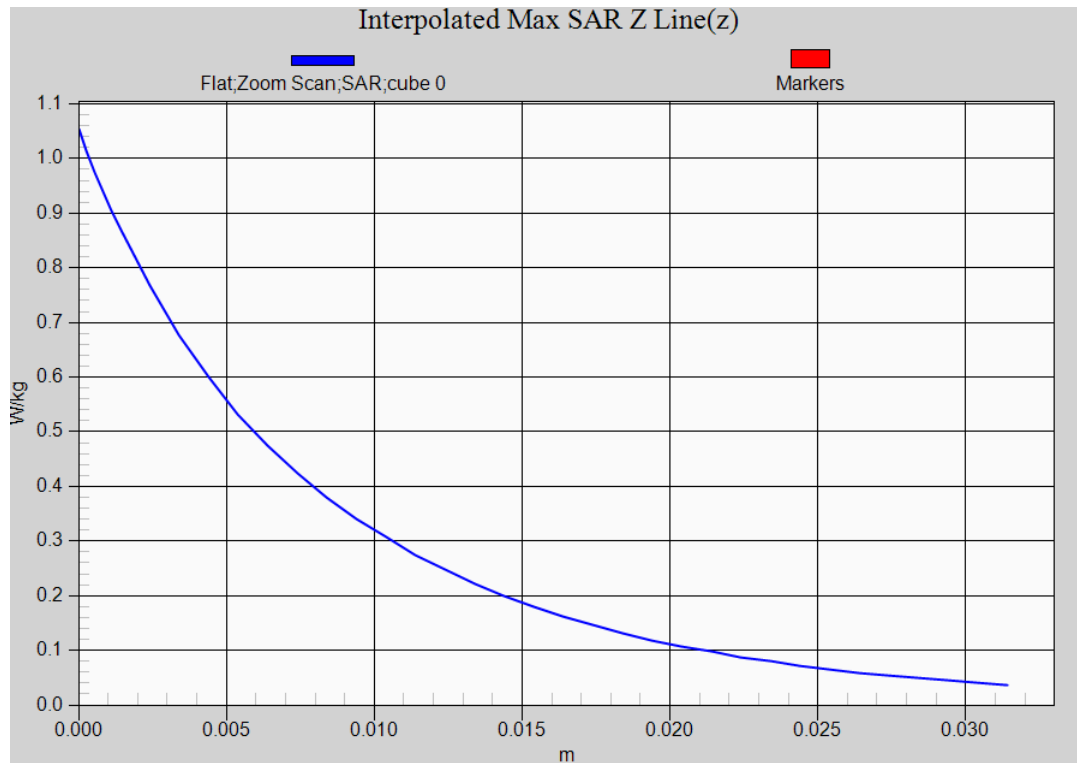

Test Laboratory: DEKRA

Date: 2022/02/23

09 LTE Band4 QPSK 20M 20300 1RB-0 Bottom-Speed_0mm**DUT: 7c Modular Platform; Type: QSIP7180**

Communication System: UID 0, LTE Band4; Frequency: 1745 MHz;

Communication System PAR: 0 dB

Medium parameters used: $f = 1745$ MHz; $\sigma = 1.35$ S/m; $\epsilon_r = 40.51$; $\rho = 1000$ kg/m³

Phantom section: Flat Section

Ambient Temperature (°C) : 23.1, Liquid Temperature (°C) : 22.4

Measurement Standard: DASYS (IEEE/IEC/ANSI C63.19-2011)

DASY5 Configuration:

- Probe: EX3DV4 - SN3698; ConvF(7.96, 7.96, 7.96); Calibrated: 2021/11/24;
- Sensor-Surface: 1.4mm (Mechanical Surface Detection)
- Electronics: DAE4 Sn1207; Calibrated: 2021/11/22
- Phantom: SAM with left table; Type: SAM;
- Measurement SW: DASYS2, Version 52.10 (0); SEMCAD X Version 14.6.10 (7417)

Configuration/Flat/Area Scan (9x10x1): Measurement grid: dx=15mm, dy=15mm

Maximum value of SAR (measured) = 0.842 W/kg

Configuration/Flat/Zoom Scan (5x5x7)/Cube 0: Measurement grid: dx=8mm, dy=8mm, dz=5mm

Reference Value = 16.77 V/m; Power Drift = 0.14 dB

Peak SAR (extrapolated) = 1.06 W/kg

SAR(1 g) = 0.580 W/kg; SAR(10 g) = 0.322 W/kg

Maximum value of SAR (measured) = 0.866 W/kg

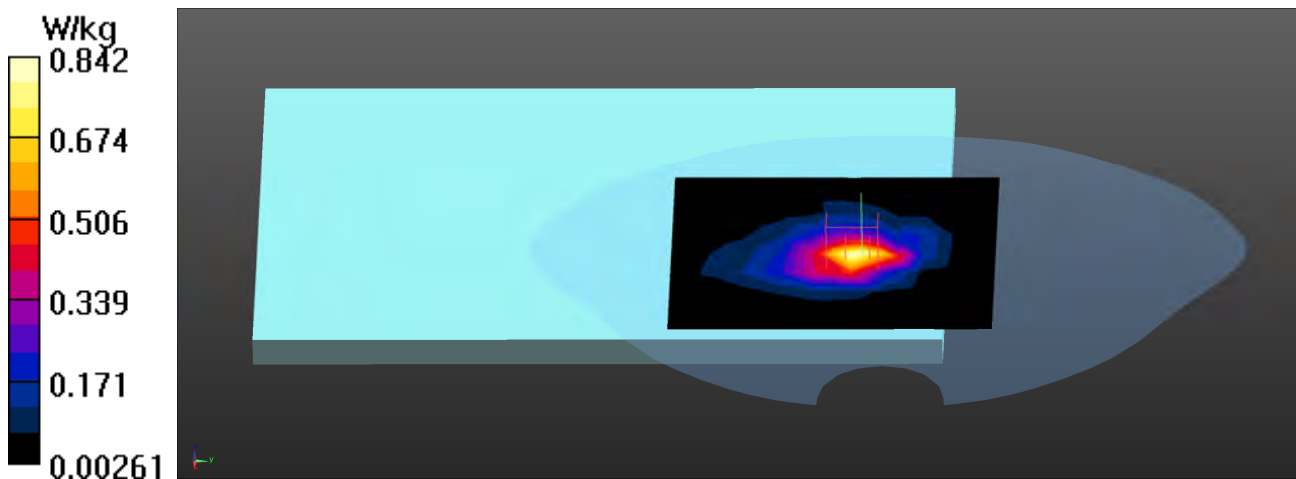

LTE Band 4 QPSK 20M 1RB-0 Bottom (Speed 0mm) Z-Axis plot

Channel: 20300

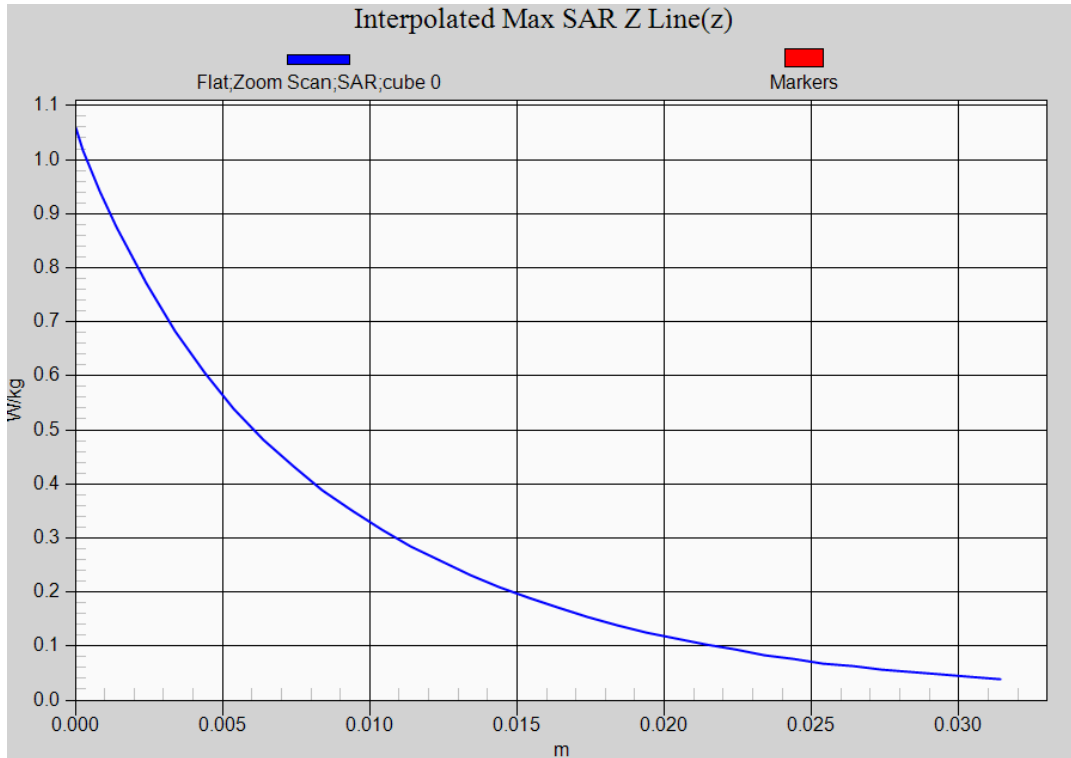

Test Laboratory: DEKRA

Date: 2022/02/22

10_LTE_Band5_QPSK_10M_20450_25RB-12_Bottom-Speed_0mm**DUT: 7c Modular Platform; Type: QSIP7180**

Communication System: UID 0, LTE Band5; Frequency: 829 MHz;

Communication System PAR: 0 dB

Medium parameters used: $f = 829$ MHz; $\sigma = 0.89$ S/m; $\epsilon_r = 41.45$; $\rho = 1000$ kg/m³

Phantom section: Flat Section

Ambient Temperature (°C) : 23.2, Liquid Temperature (°C) : 22.1

Measurement Standard: DASYS (IEEE/IEC/ANSI C63.19-2011)

DASY5 Configuration:

- Probe: EX3DV4 - SN3698; ConvF(8.9, 8.9, 8.9); Calibrated: 2021/11/24;
- Sensor-Surface: 1.4mm (Mechanical Surface Detection)
- Electronics: DAE4 Sn1207; Calibrated: 2021/11/22
- Phantom: SAM with left table; Type: SAM;
- Measurement SW: DASYS2, Version 52.10 (0); SEMCAD X Version 14.6.10 (7417)

Configuration/Flat/Area Scan (9x10x1): Measurement grid: dx=15mm, dy=15mm

Maximum value of SAR (measured) = 0.748 W/kg

Configuration/Flat/Zoom Scan (5x5x7)/Cube 0: Measurement grid: dx=8mm, dy=8mm, dz=5mm

Reference Value = 23.56 V/m; Power Drift = 0.03 dB

Peak SAR (extrapolated) = 0.989 W/kg

SAR(1 g) = 0.616 W/kg; SAR(10 g) = 0.388 W/kg

Maximum value of SAR (measured) = 0.857 W/kg

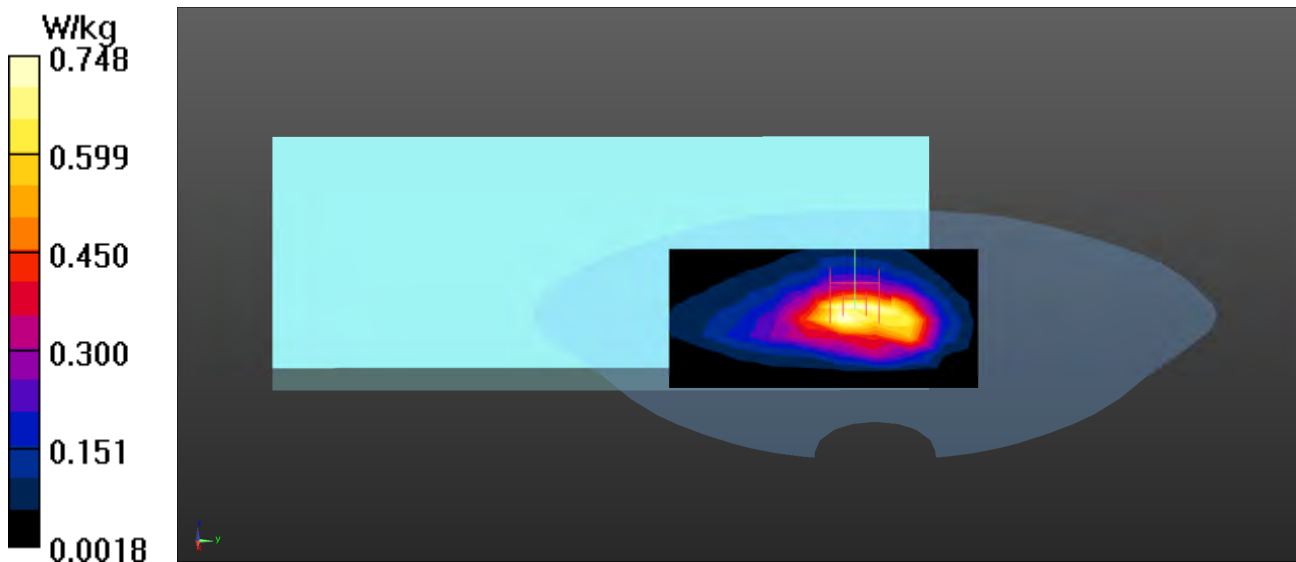

LTE Band 5 QPSK 10M 1RB-0 Bottom (Speed_0mm) Z-Axis plot

Channel: 20450

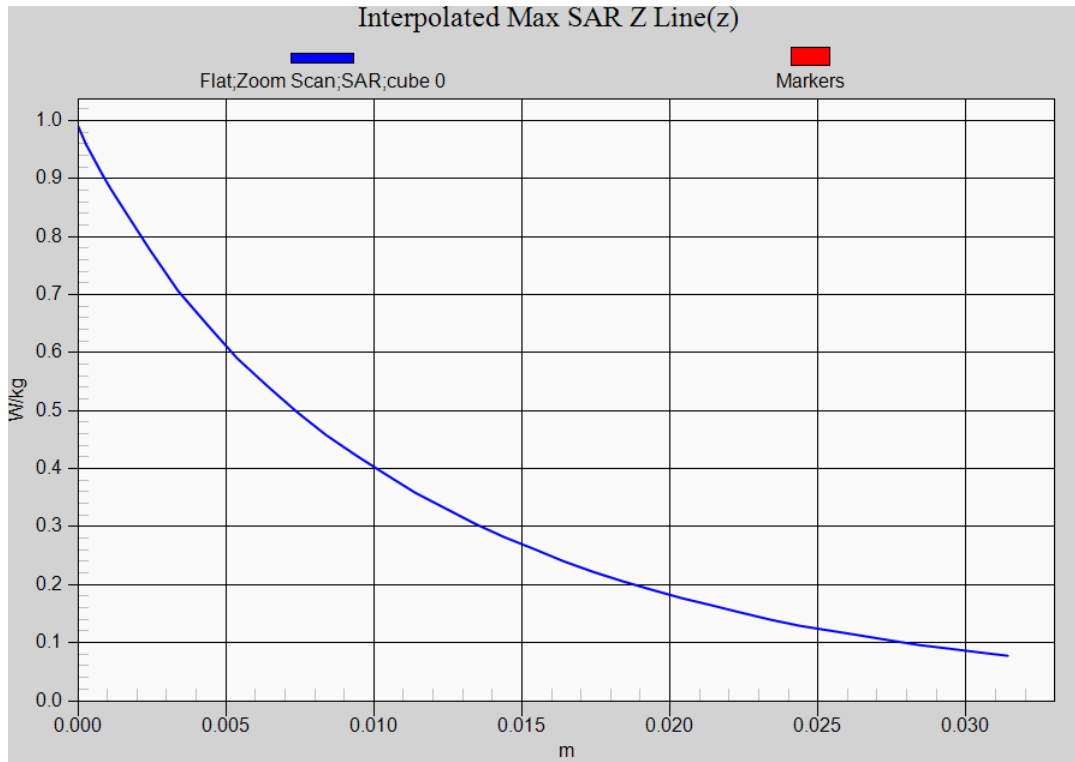

Test Laboratory: DEKRA

Date: 2022/03/09

11_LTE_Band7_QPSK_20M_20850_1RB-0_Bottom-Speed_0mm**DUT: 7c Modular Platform; Type: QSIP7180**

Communication System: UID 0, LTE Band7; Frequency: 2510 MHz;

Communication System PAR: 0 dB

Medium parameters used: $f = 2510$ MHz; $\sigma = 1.89$ S/m; $\epsilon_r = 40.06$; $\rho = 1000$ kg/m³

Phantom section: Flat Section

Ambient Temperature (°C) : 23.1, Liquid Temperature (°C) : 22.3

Measurement Standard: DASY5 (IEEE/IEC/ANSI C63.19-2011)

DASY5 Configuration:

- Probe: EX3DV4 - SN3698; ConvF(6.97, 6.97, 6.97); Calibrated: 2021/11/24;
- Sensor-Surface: 1.4mm (Mechanical Surface Detection)
- Electronics: DAE4 Sn1207; Calibrated: 2021/11/22
- Phantom: SAM with left table; Type: SAM;
- Measurement SW: DASY52, Version 52.10 (0); SEMCAD X Version 14.6.10 (7417)

Configuration/Flat/Area Scan (10x12x1): Measurement grid: dx=12mm, dy=12mm

Maximum value of SAR (measured) = 1.40 W/kg

Configuration/Flat/Zoom Scan (7x7x7)/Cube 0: Measurement grid: dx=5mm, dy=5mm, dz=5mm

Reference Value = 21.14 V/m; Power Drift = 0.09 dB

Peak SAR (extrapolated) = 1.76 W/kg

SAR(1 g) = 0.909 W/kg; SAR(10 g) = 0.494 W/kg

Maximum value of SAR (measured) = 1.41 W/kg

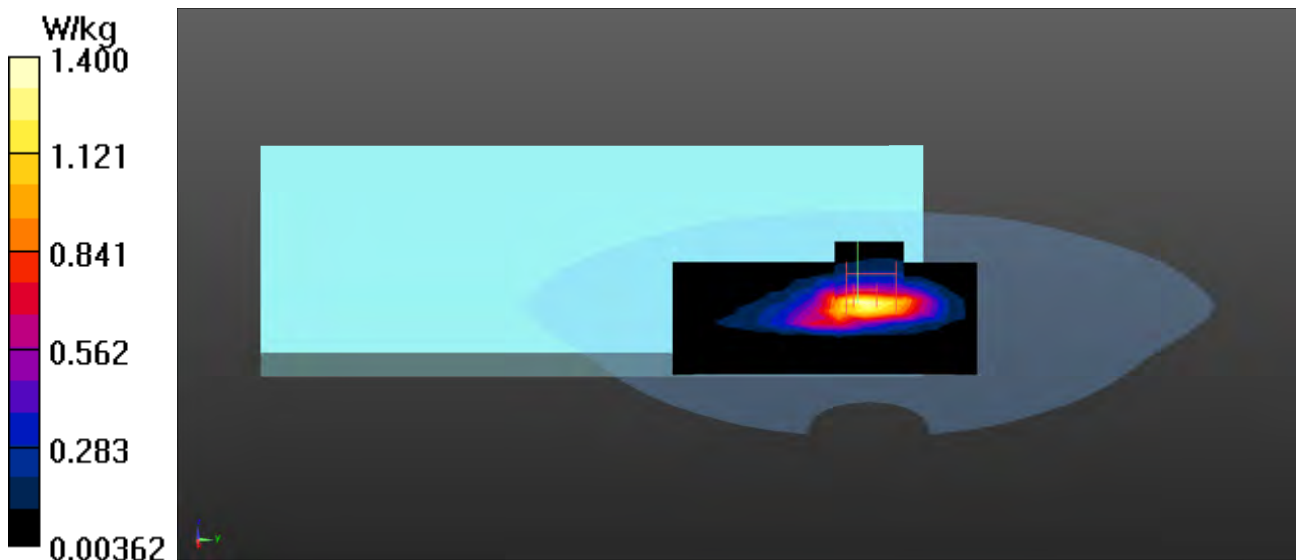

LTE Band 7 QPSK 20M 1RB-99 Bottom (Speed 15mm) Z-Axis plot

Channel: 21350

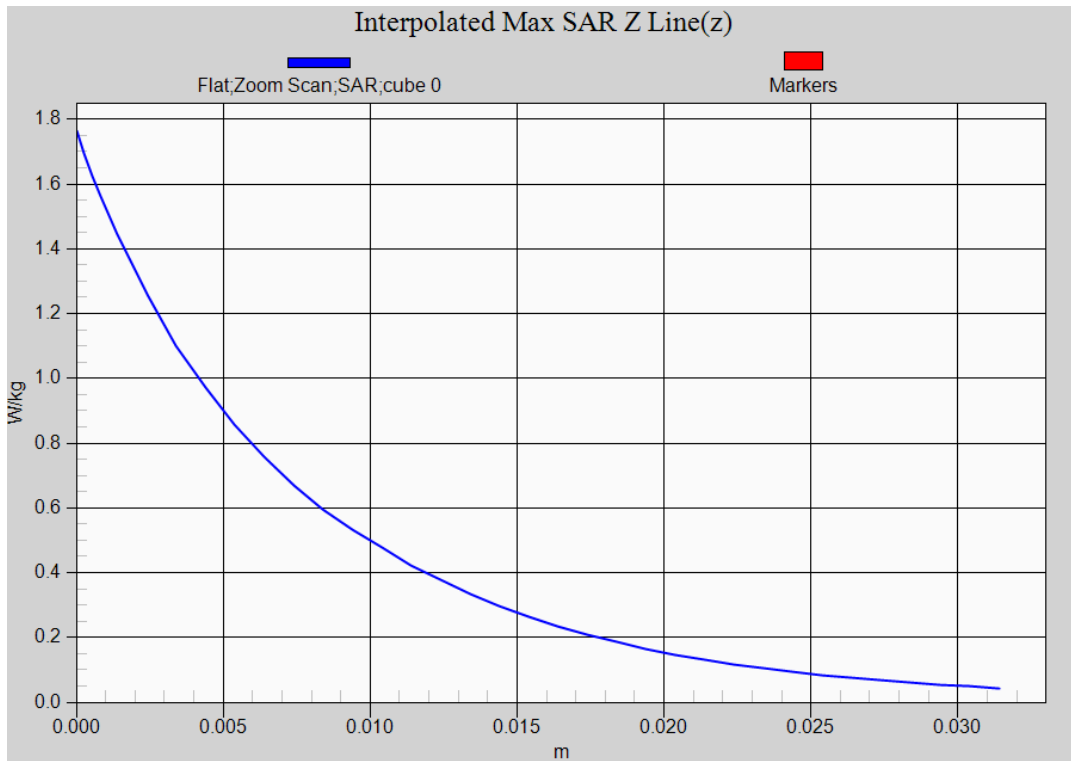

Test Laboratory: DEKRA

Date: 2022/03/07

12_LTE_Band12_QPSK_10M_23130_1RB-49_Bottom-Speed_0mm**DUT: 7c Modular Platform; Type: QSIP7180**

Communication System: UID 0, LTE Band12; Frequency: 711 MHz;

Communication System PAR: 0 dB

Medium parameters used: $f = 711$ MHz; $\sigma = 0.88$ S/m; $\epsilon_r = 42.66$; $\rho = 1000$ kg/m³

Phantom section: Flat Section

Ambient Temperature (°C) : 23.2, Liquid Temperature (°C) : 22.1

Measurement Standard: DASYS5 (IEEE/IEC/ANSI C63.19-2011)

DASY5 Configuration:

- Probe: EX3DV4 - SN3698; ConvF(9.1, 9.1, 9.1); Calibrated: 2021/11/24;
- Sensor-Surface: 1.4mm (Mechanical Surface Detection)
- Electronics: DAE4 Sn1207; Calibrated: 2021/11/22
- Phantom: SAM with left table; Type: SAM;
- Measurement SW: DASYS52, Version 52.10 (0); SEMCAD X Version 14.6.10 (7417)

Configuration/Flat/Area Scan (9x10x1): Measurement grid: dx=15mm, dy=15mm

Maximum value of SAR (measured) = 0.789 W/kg

Configuration/Flat/Zoom Scan (5x5x7)/Cube 0: Measurement grid: dx=8mm, dy=8mm, dz=5mm

Reference Value = 23.45 V/m; Power Drift = -0.00 dB

Peak SAR (extrapolated) = 0.927 W/kg

SAR(1 g) = 0.561 W/kg; SAR(10 g) = 0.349 W/kg

Maximum value of SAR (measured) = 0.794 W/kg

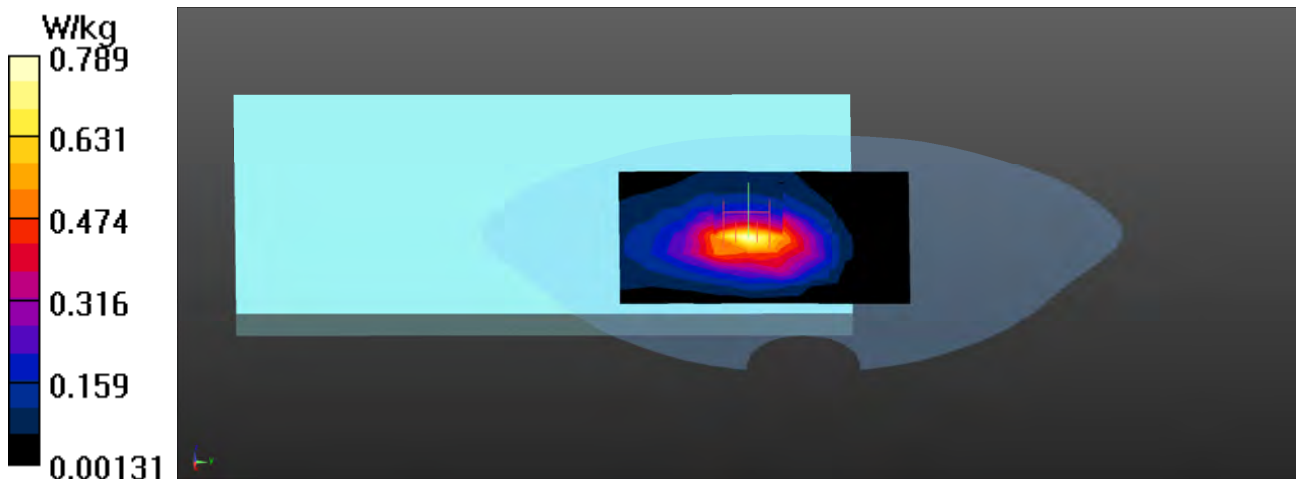

LTE Band 12 QPSK 10M 25RB-0 Bottom (Speed_0mm) Z-Axis plot

Channel: 23095

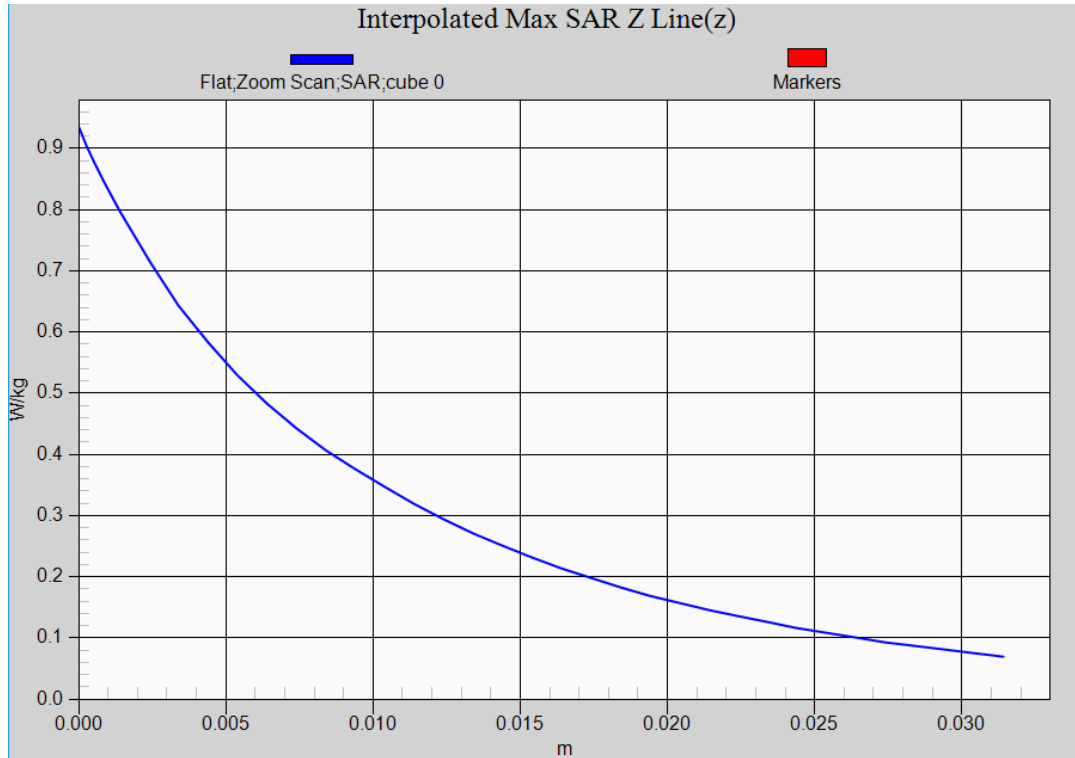

Test Laboratory: DEKRA

Date: 2022/02/22

13_LTE_Band13_QPSK_20M_23230_25RB-0_Bottom-Speed_0mm**DUT: 7c Modular Platform; Type: QSIP7180**

Communication System: UID 0, LTE Band13; Frequency: 782 MHz;

Communication System PAR: 0 dB

Medium parameters used: $f = 782$ MHz; $\sigma = 0.88$ S/m; $\epsilon_r = 41.97$; $\rho = 1000$ kg/m³

Phantom section: Flat Section

Ambient Temperature (°C) : 23.2, Liquid Temperature (°C) : 22.1

Measurement Standard: DASYS (IEEE/IEC/ANSI C63.19-2011)

DASY5 Configuration:

- Probe: EX3DV4 - SN3698; ConvF(9.1, 9.1, 9.1); Calibrated: 2021/11/24;
- Sensor-Surface: 1.4mm (Mechanical Surface Detection)
- Electronics: DAE4 Sn1207; Calibrated: 2021/11/22
- Phantom: SAM with left table; Type: SAM;
- Measurement SW: DASYS2, Version 52.10 (0); SEMCAD X Version 14.6.10 (7417)

Configuration/Flat/Area Scan (9x10x1): Measurement grid: dx=15mm, dy=15mm

Maximum value of SAR (measured) = 0.866 W/kg

Configuration/Flat/Zoom Scan (5x5x7)/Cube 0: Measurement grid: dx=8mm, dy=8mm, dz=5mm

Reference Value = 25.07 V/m; Power Drift = 0.03 dB

Peak SAR (extrapolated) = 1.08 W/kg

SAR(1 g) = 0.673 W/kg; SAR(10 g) = 0.425 W/kg

Maximum value of SAR (measured) = 0.930 W/kg

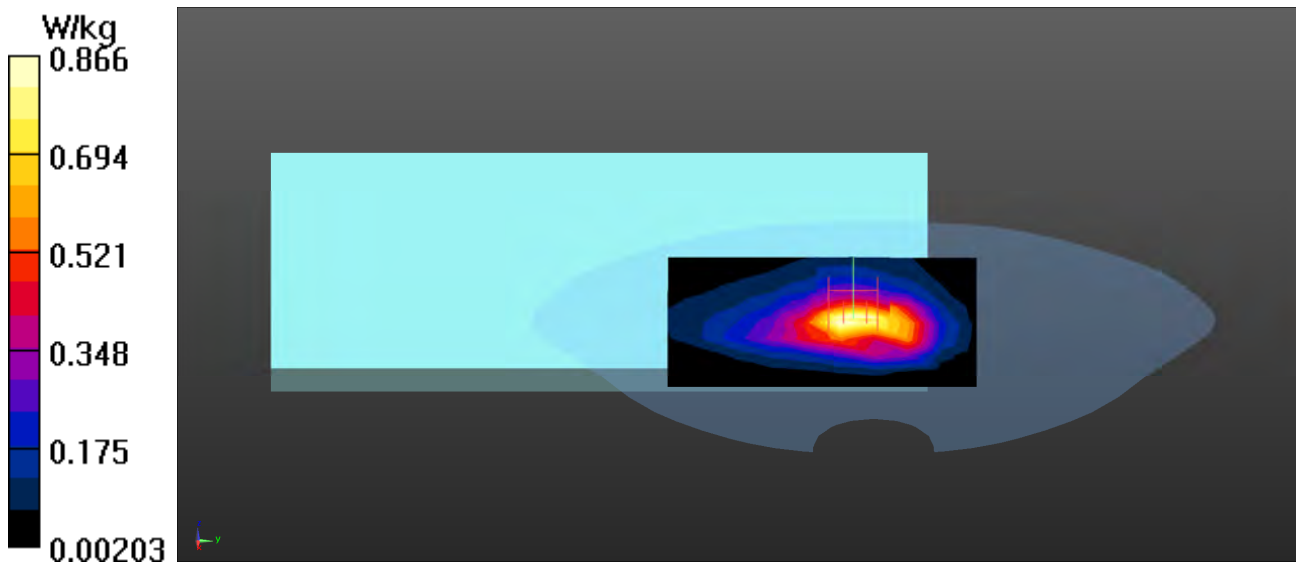

LTE Band 13 QPSK 20M 1RB-0 Bottom (Speed_0mm) Z-Axis plot

Channel: 23230

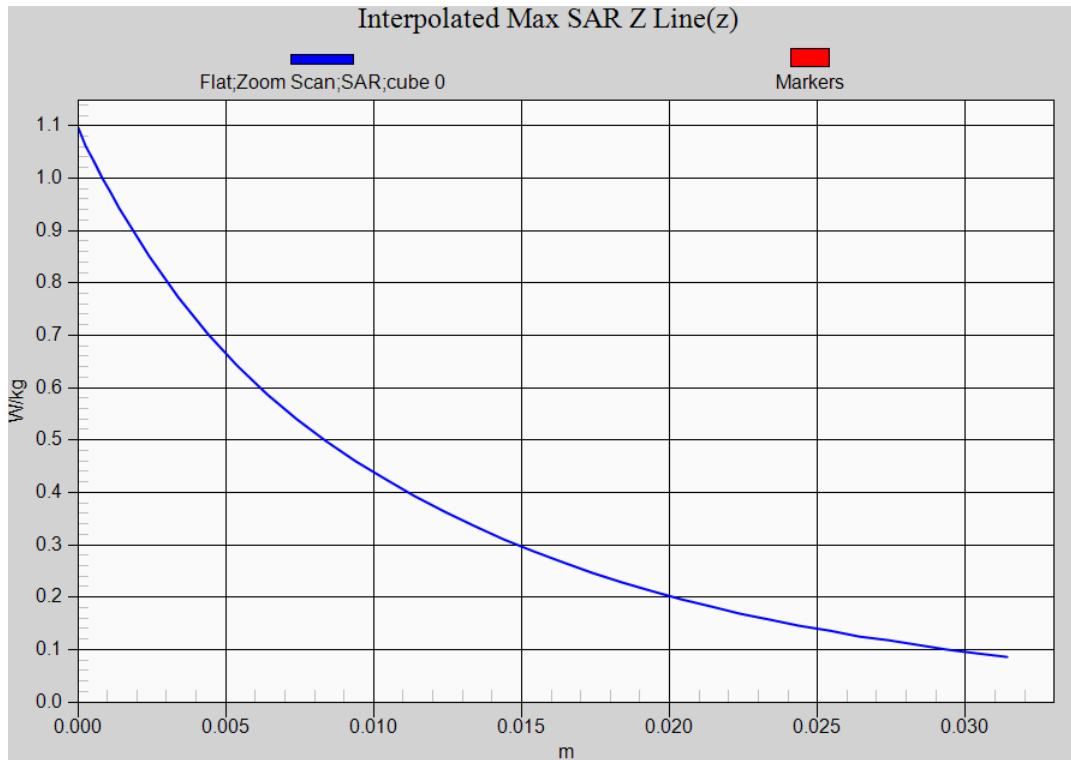

Test Laboratory: DEKRA

Date: 2022/03/08

14_LTE_Band14_QPSK_10M_23330_1RB-0_Bottom-Speed_0mm**DUT: 7c Modular Platform; Type: QSIP7180**

Communication System: UID 0, LTE Band14; Frequency: 793 MHz;

Communication System PAR: 0 dB

Medium parameters used: $f = 793$ MHz; $\sigma = 0.9$ S/m; $\epsilon_r = 41.44$; $\rho = 1000$ kg/m³

Phantom section: Flat Section

Ambient Temperature (°C) : 23.3, Liquid Temperature (°C) : 22.1

Measurement Standard: DASYS (IEEE/IEC/ANSI C63.19-2011)

DASY5 Configuration:

- Probe: EX3DV4 - SN3698; ConvF(9.1, 9.1, 9.1); Calibrated: 2021/11/24;
- Sensor-Surface: 1.4mm (Mechanical Surface Detection)
- Electronics: DAE4 Sn1207; Calibrated: 2021/11/22
- Phantom: SAM with left table; Type: SAM;
- Measurement SW: DASYS2, Version 52.10 (0); SEMCAD X Version 14.6.10 (7417)

Configuration/Flat/Area Scan (9x10x1): Measurement grid: dx=15mm, dy=15mm

Maximum value of SAR (measured) = 0.970 W/kg

Configuration/Flat/Zoom Scan (5x5x7)/Cube 0: Measurement grid: dx=8mm, dy=8mm, dz=5mm

Reference Value = 28.61 V/m; Power Drift = -0.01 dB

Peak SAR (extrapolated) = 1.18 W/kg

SAR(1 g) = 0.723 W/kg; SAR(10 g) = 0.452 W/kg

Maximum value of SAR (measured) = 1.01 W/kg

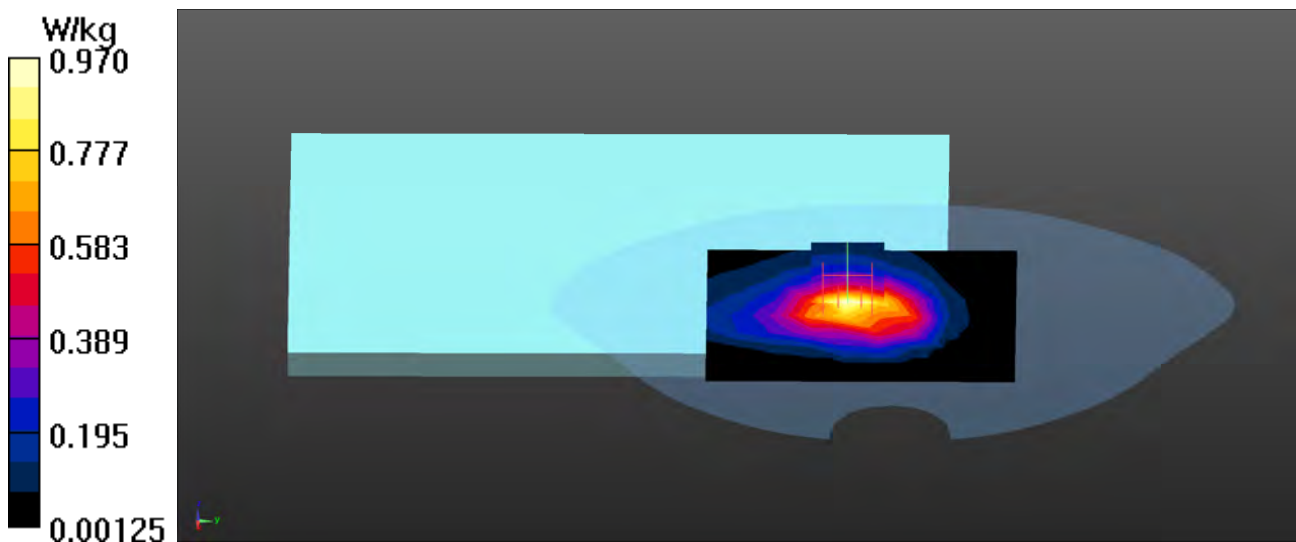

LTE Band 14 QPSK 10M 1RB-0 Bottom (Speed 0mm), Z-Axis plot

Channel: 23330

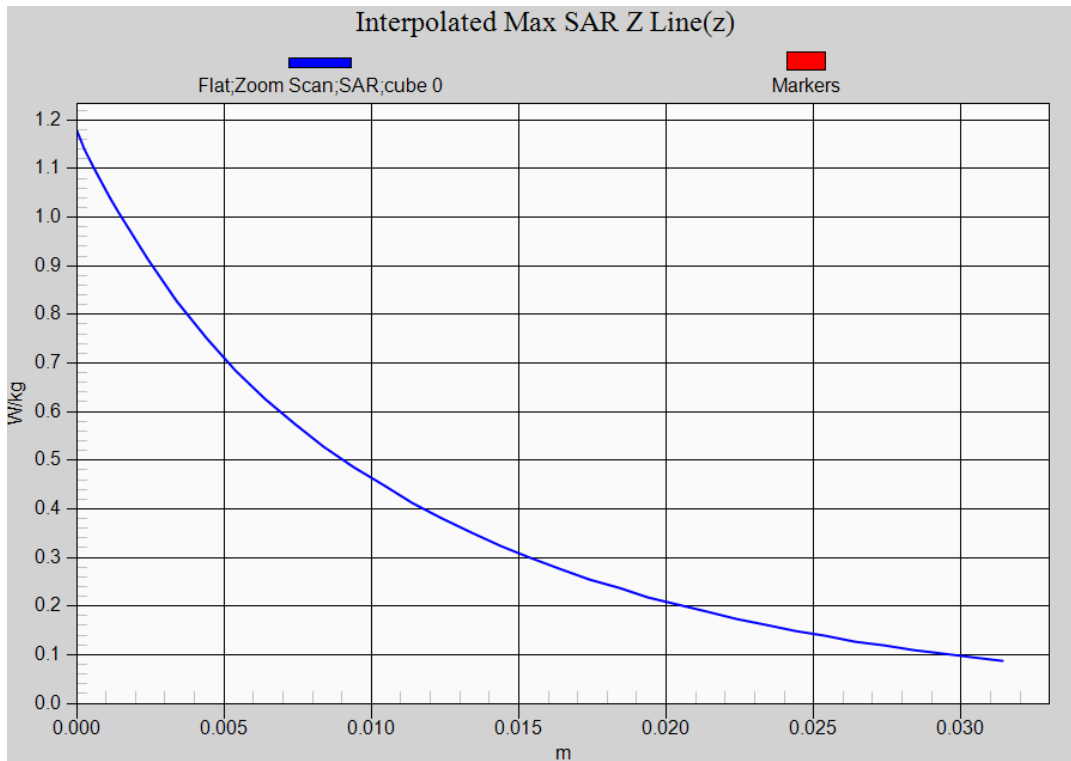

Test Laboratory: DEKRA

Date: 2022/03/08

15_LTE_Band17_QPSK_10M_23780_1RB-49_Bottom-Speed_0mm

DUT: 7c Modular Platform; Type: QSIP7180

Communication System: UID 0, LTE Band17; Frequency: 709 MHz;

Communication System PAR: 0 dB

Medium parameters used: $f = 709$ MHz; $\sigma = 0.87$ S/m; $\epsilon_r = 42.49$; $\rho = 1000$ kg/m³

Phantom section: Flat Section

Ambient Temperature (°C) : 23.3, Liquid Temperature (°C) : 22.1

Measurement Standard: DASYS (IEEE/IEC/ANSI C63.19-2011)

DASY5 Configuration:

- Probe: EX3DV4 - SN3698; ConvF(9.1, 9.1, 9.1); Calibrated: 2021/11/24;
- Sensor-Surface: 1.4mm (Mechanical Surface Detection)
- Electronics: DAE4 Sn1207; Calibrated: 2021/11/22
- Phantom: SAM with left table; Type: SAM;
- Measurement SW: DASYS2, Version 52.10 (0); SEMCAD X Version 14.6.10 (7417)

Configuration/Flat/Area Scan (9x10x1): Measurement grid: dx=15mm, dy=15mm

Maximum value of SAR (measured) = 0.857 W/kg

Configuration/Flat/Zoom Scan (5x5x7)/Cube 0: Measurement grid: dx=8mm, dy=8mm, dz=5mm

Reference Value = 25.51 V/m; Power Drift = 0.03 dB

Peak SAR (extrapolated) = 1.05 W/kg

SAR(1 g) = 0.639 W/kg; SAR(10 g) = 0.399 W/kg

Maximum value of SAR (measured) = 0.893 W/kg

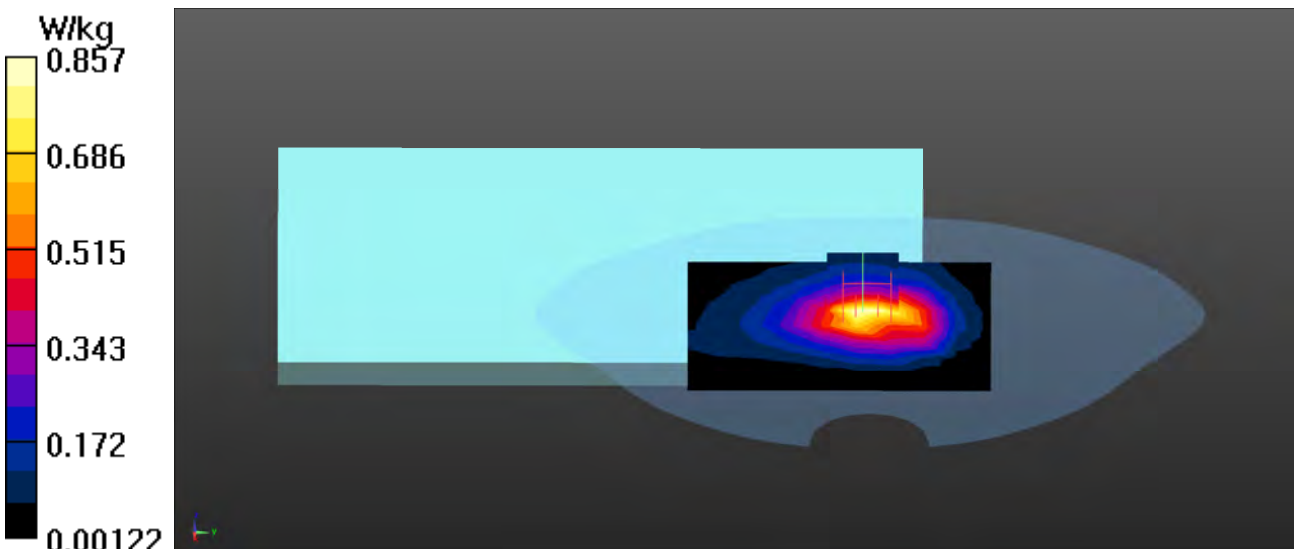

LTE Band 17 QPSK 10M 1RB-49_Bottom (Speed_0mm), Z-Axis plot

Channel: 23790

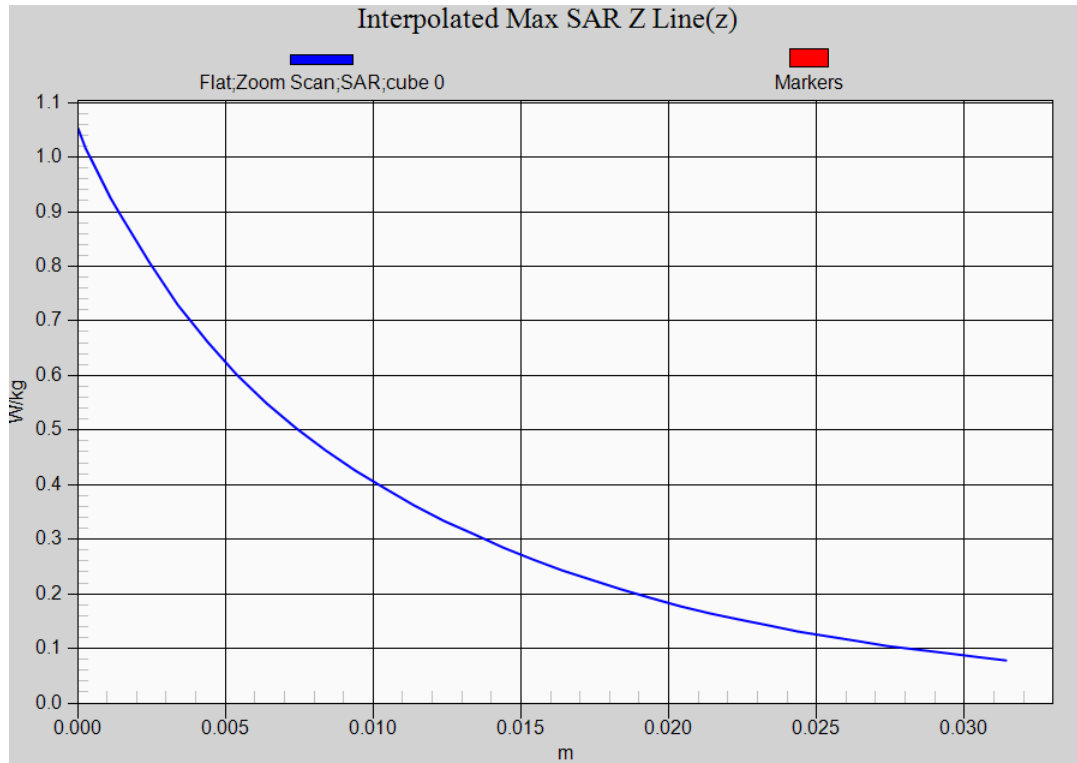

Test Laboratory: DEKRA

Date: 2022/03/09

16_LTE_Band25_QPSK_20M_26590_1RB-0_Bottom-Speed_0mm**DUT: 7c Modular Platform; Type: QSIP7180**

Communication System: UID 0, LTE Band25; Frequency: 1905 MHz;

Communication System PAR: 0 dB

Medium parameters used: $f = 1905$ MHz; $\sigma = 1.38$ S/m; $\epsilon_r = 39.99$; $\rho = 1000$ kg/m³

Phantom section: Flat Section

Ambient Temperature (°C) : 23.1, Liquid Temperature (°C) : 22.3

Measurement Standard: DASY5 (IEEE/IEC/ANSI C63.19-2011)

DASY5 Configuration:

- Probe: EX3DV4 - SN3698; ConvF(7.6, 7.6, 7.6); Calibrated: 2021/11/24;
- Sensor-Surface: 1.4mm (Mechanical Surface Detection)
- Electronics: DAE4 Sn1207; Calibrated: 2021/11/22
- Phantom: SAM with left table; Type: SAM;
- Measurement SW: DASY52, Version 52.10 (0); SEMCAD X Version 14.6.10 (7417)

Configuration/Flat/Area Scan (9x10x1): Measurement grid: dx=15mm, dy=15mm

Maximum value of SAR (measured) = 0.850 W/kg

Configuration/Flat/Zoom Scan (5x5x7)/Cube 0: Measurement grid: dx=8mm, dy=8mm, dz=5mm

Reference Value = 9.997 V/m; Power Drift = 0.01 dB

Peak SAR (extrapolated) = 1.12 W/kg

SAR(1 g) = 0.611 W/kg; SAR(10 g) = 0.335 W/kg

Maximum value of SAR (measured) = 0.924 W/kg

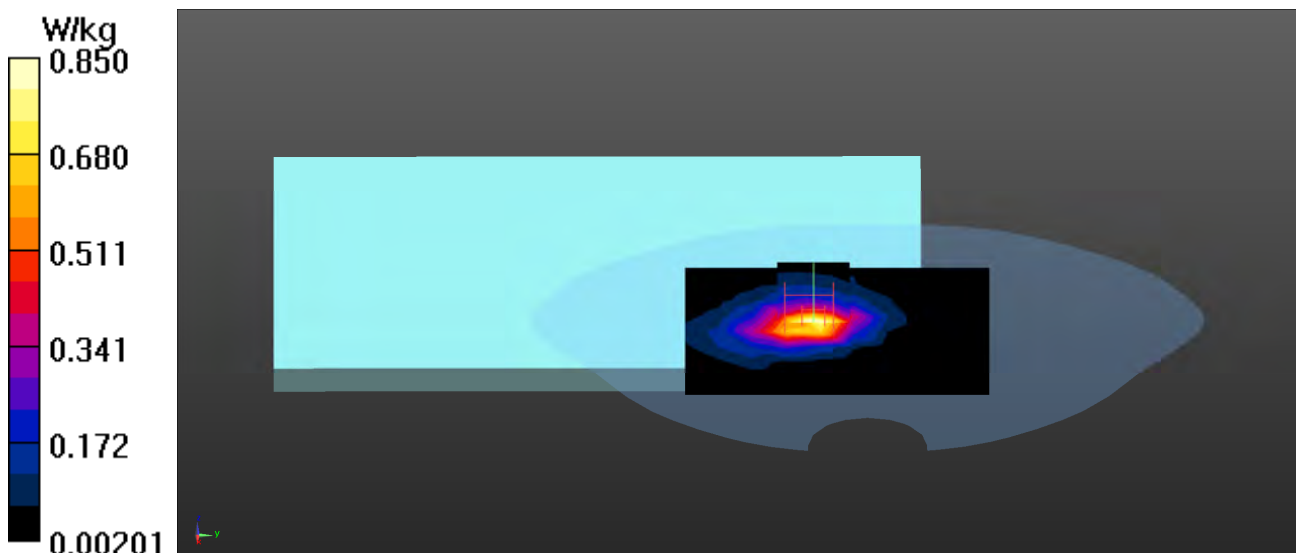

LTE Band 25 QPSK 20M 1RB-0 Bottom (Speed 0mm) Z-Axis plot

Channel: 26590

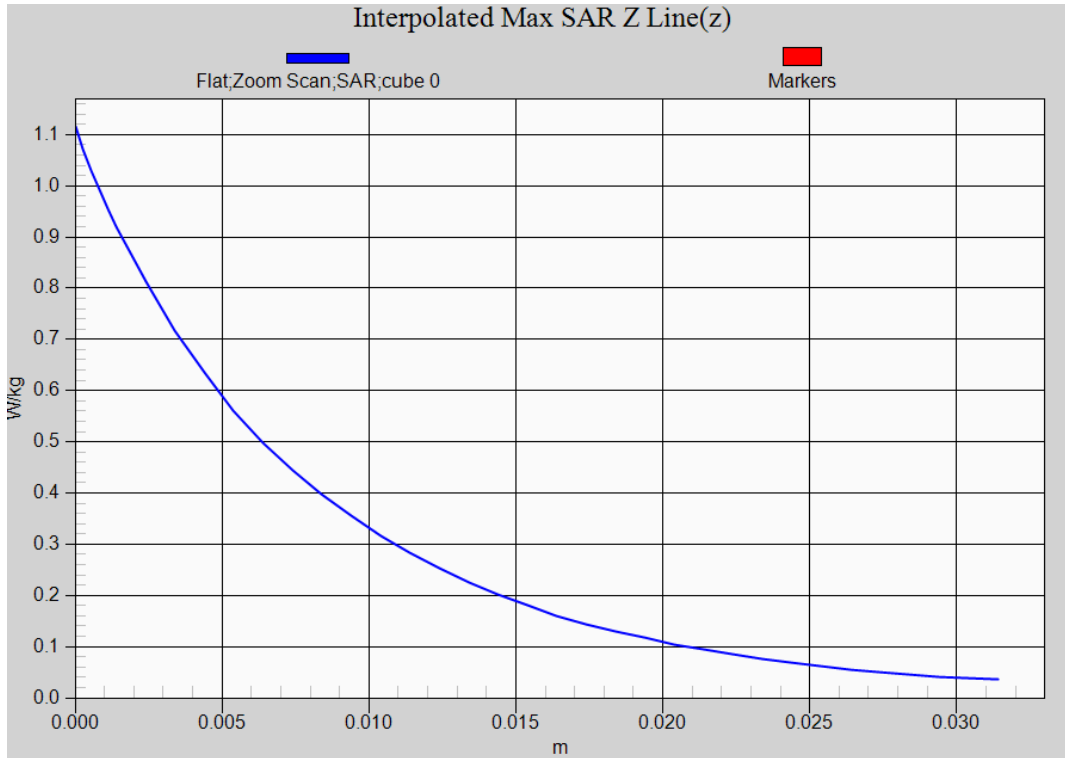

Test Laboratory: DEKRA

Date: 2022/03/08

17_LTE_Band26_QPSK_15M_26765_1RB-74_Bottom-Speed_0mm

DUT: 7c Modular Platform; Type: QSIP7180

Communication System: UID 0, LTE Band26; Frequency: 821.5 MHz;

Communication System PAR: 0 dB

Medium parameters used: $f = 821.5$ MHz; $\sigma = 0.9$ S/m; $\epsilon_r = 41.08$; $\rho = 1000$ kg/m³

Phantom section: Flat Section

Ambient Temperature (°C) : 23.3, Liquid Temperature (°C) : 22.1

Measurement Standard: DASYS (IEEE/IEC/ANSI C63.19-2011)

DASY5 Configuration:

- Probe: EX3DV4 - SN3698; ConvF(8.9, 8.9, 8.9); Calibrated: 2021/11/24;
- Sensor-Surface: 1.4mm (Mechanical Surface Detection)
- Electronics: DAE4 Sn1207; Calibrated: 2021/11/22
- Phantom: SAM with left table; Type: SAM;
- Measurement SW: DASYS2, Version 52.10 (0); SEMCAD X Version 14.6.10 (7417)

Configuration/Flat/Area Scan (10x11x1): Measurement grid: dx=15mm, dy=15mm

Maximum value of SAR (measured) = 0.868 W/kg

Configuration/Flat/Zoom Scan (5x5x7)/Cube 0: Measurement grid: dx=8mm, dy=8mm, dz=5mm

Reference Value = 25.26 V/m; Power Drift = 0.06 dB

Peak SAR (extrapolated) = 1.05 W/kg

SAR(1 g) = 0.650 W/kg; SAR(10 g) = 0.404 W/kg

Maximum value of SAR (measured) = 0.884 W/kg

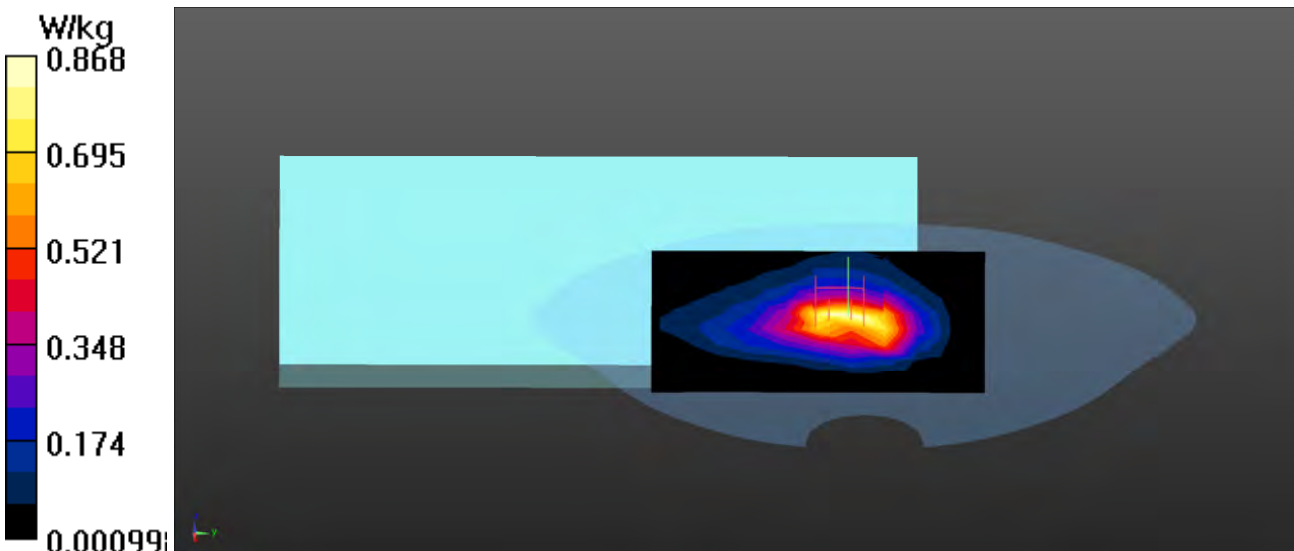

LTE Band 26 QPSK 15M 1RB-74 Bottom (Speed_0mm) Z-Axis plot

Channel: 26765

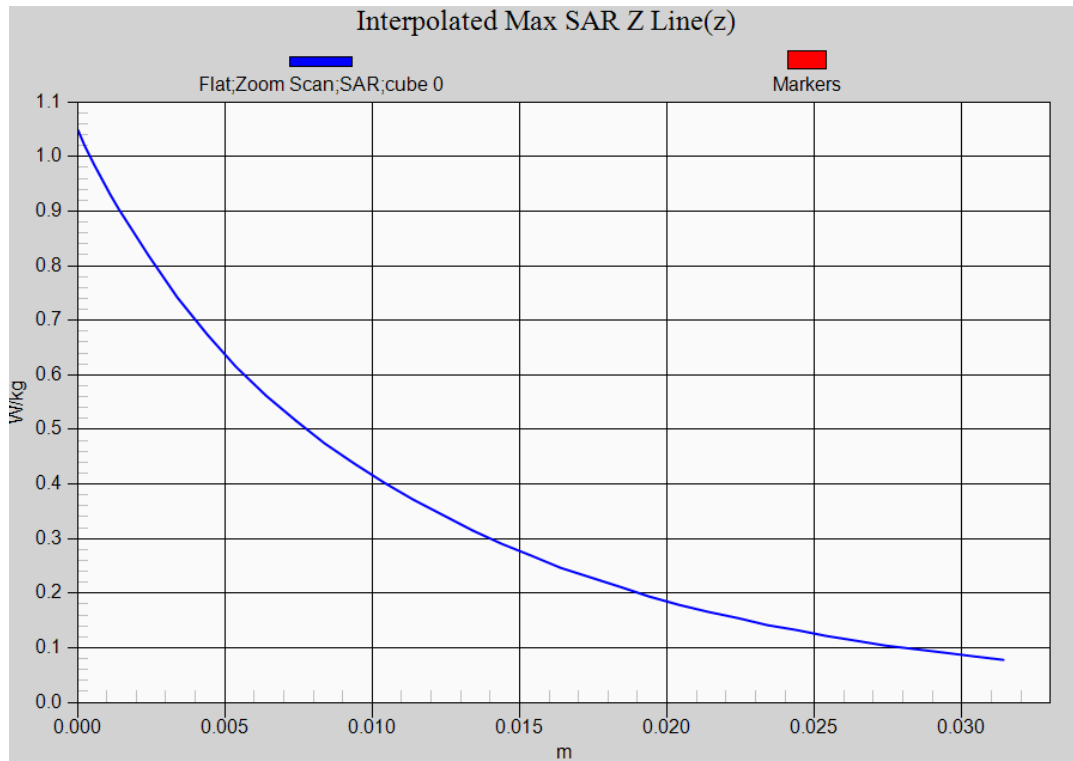

Test Laboratory: DEKRA

Date: 2022/03/09

18_LTE_Band30_QPSK_10M_27710_1RB-25_Bottom-Speed_15mm

DUT: 7c Modular Platform; Type: QSIP7180

Communication System: UID 0, LTE BAND 30; Frequency: 2310 MHz;

Communication System PAR: 0 dB

Medium parameters used: $f = 2310$ MHz; $\sigma = 1.66$ S/m; $\epsilon_r = 39.33$; $\rho = 1000$ kg/m³

Phantom section: Flat Section

Ambient Temperature (°C) : 23.1, Liquid Temperature (°C) : 22.3

Measurement Standard: DASY5 (IEEE/IEC/ANSI C63.19-2011)

DASY5 Configuration:

- Probe: EX3DV4 - SN3698; ConvF(7.39, 7.39, 7.39); Calibrated: 2021/11/24;
- Sensor-Surface: 1.4mm (Mechanical Surface Detection)
- Electronics: DAE4 Sn1207; Calibrated: 2021/11/22
- Phantom: SAM with left table; Type: SAM;
- Measurement SW: DASY52, Version 52.10 (0); SEMCAD X Version 14.6.10 (7417)

Configuration/Flat/Area Scan (11x12x1): Measurement grid: dx=12mm, dy=12mm

Maximum value of SAR (measured) = 1.05 W/kg

Configuration/Flat/Zoom Scan (7x7x7)/Cube 0: Measurement grid: dx=5mm, dy=5mm, dz=5mm

Reference Value = 22.43 V/m; Power Drift = 0.08 dB

Peak SAR (extrapolated) = 1.32 W/kg

SAR(1 g) = 0.738 W/kg; SAR(10 g) = 0.425 W/kg

Maximum value of SAR (measured) = 1.10 W/kg

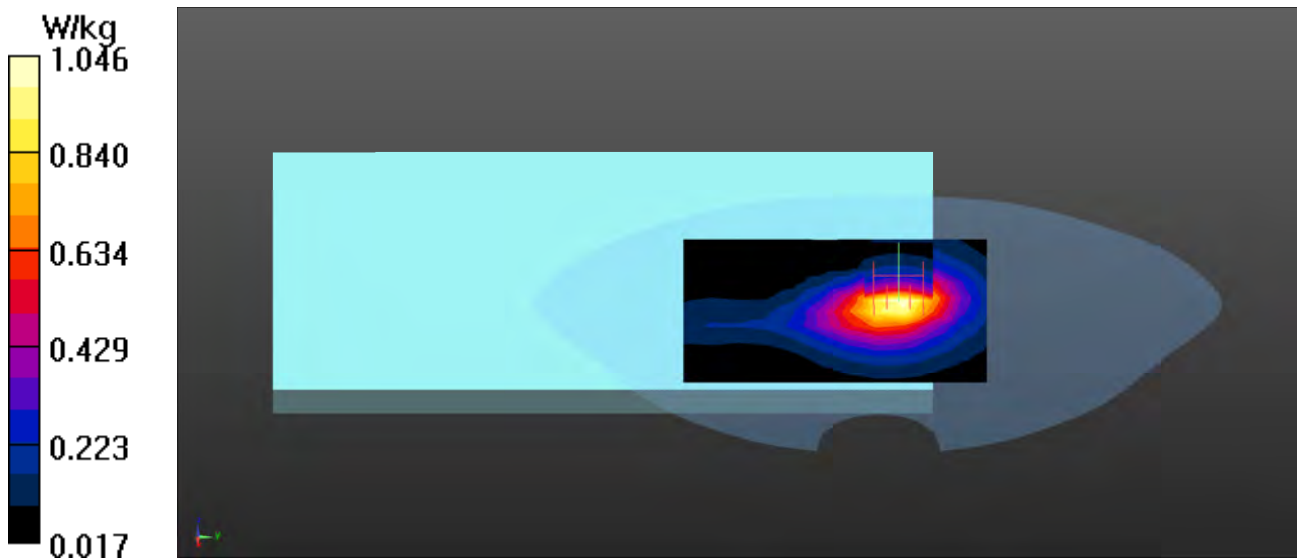

LTE Band 30 QPSK 10M 1RB-25 Bottom (Speed 15mm) Z-Axis plot

Channel: 27710

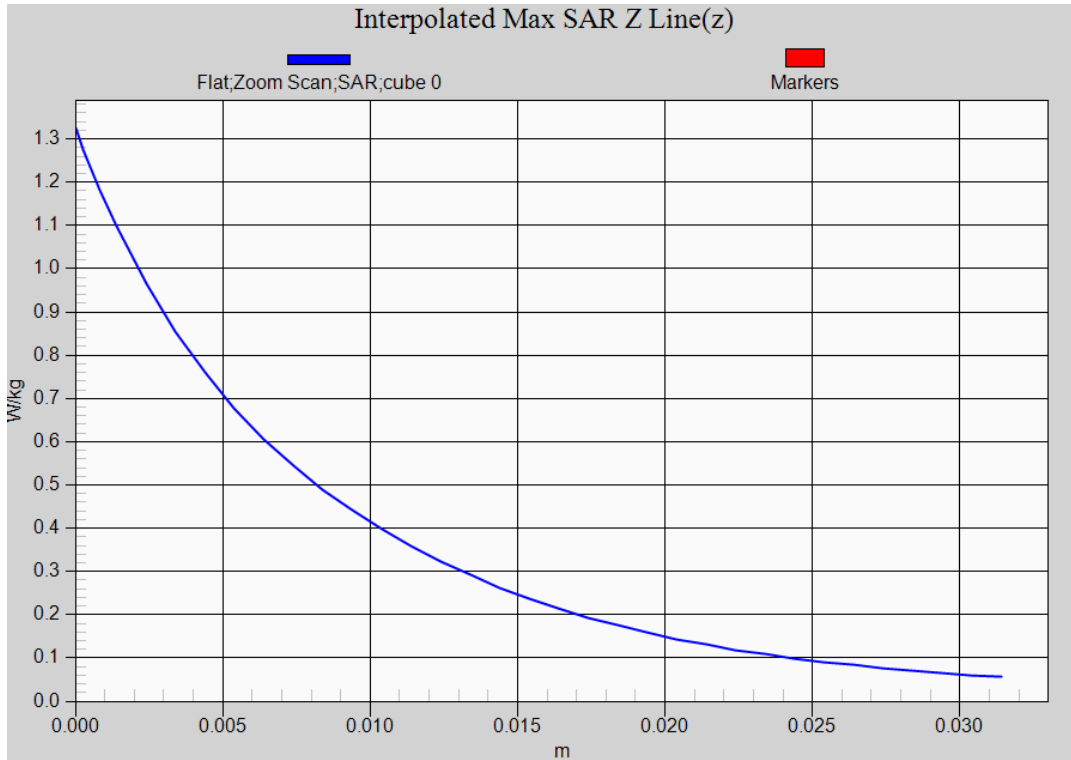

Test Laboratory: DEKRA

Date: 2022/03/09

19 LTE_Band38_QPSK_20M_37850_1RB-0_Bottom-Speed_15mm**DUT: 7c Modular Platform; Type: QSIP7180**

Communication System: UID 0, FCC LTE-TDD Band38; Frequency: 2580 MHz;

Communication System PAR: 2.014 dB

Medium parameters used: $f = 2580$ MHz; $\sigma = 1.93$ S/m; $\epsilon_r = 39.22$; $\rho = 1000$ kg/m³

Phantom section: Flat Section

Ambient Temperature (°C) : 23.1, Liquid Temperature (°C) : 22.3

Measurement Standard: DASY5 (IEEE/IEC/ANSI C63.19-2011)

DASY5 Configuration:

- Probe: EX3DV4 - SN3698; ConvF(6.97, 6.97, 6.97); Calibrated: 2021/11/24;
- Sensor-Surface: 1.4mm (Mechanical Surface Detection)
- Electronics: DAE4 Sn1207; Calibrated: 2021/11/22
- Phantom: SAM with left table; Type: SAM;
- Measurement SW: DASY52, Version 52.10 (0); SEMCAD X Version 14.6.10 (7417)

Configuration/Flat/Area Scan (10x11x1): Measurement grid: dx=12mm, dy=12mm

Maximum value of SAR (measured) = 0.916 W/kg

Configuration/Flat/Zoom Scan (7x7x7)/Cube 0: Measurement grid: dx=5mm, dy=5mm, dz=5mm

Reference Value = 16.69 V/m; Power Drift = 0.06 dB

Peak SAR (extrapolated) = 1.15 W/kg

SAR(1 g) = 0.615 W/kg; SAR(10 g) = 0.343 W/kg

Maximum value of SAR (measured) = 0.943 W/kg

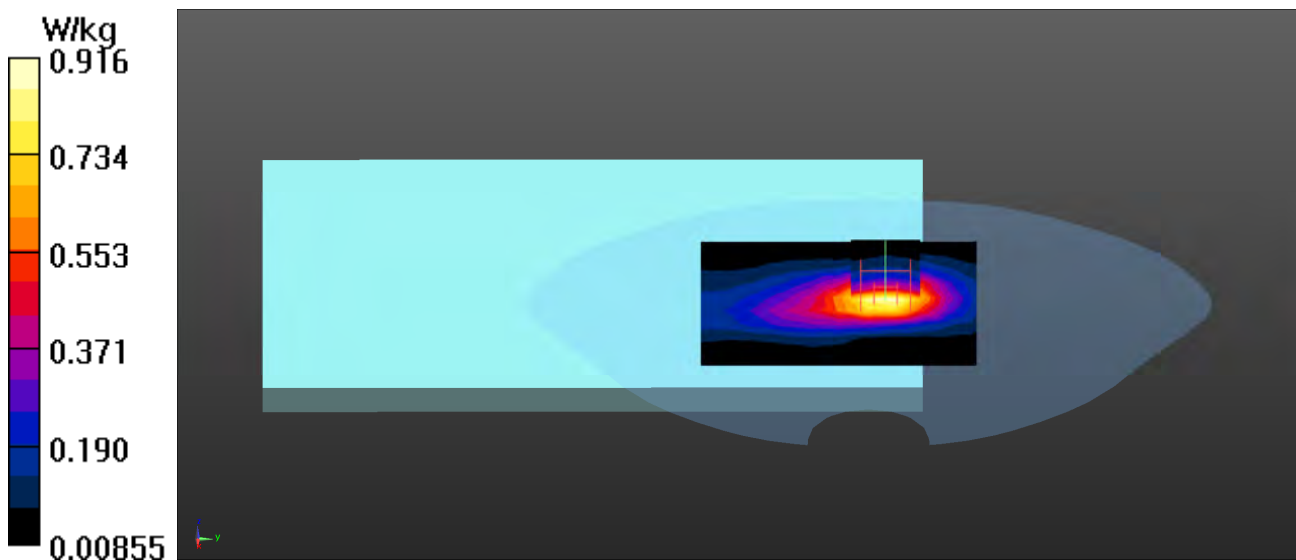

LTE Band 38 QPSK 20M 1RB-0 Bottom (Speed 0mm) Z-Axis plot

Channel: 37850

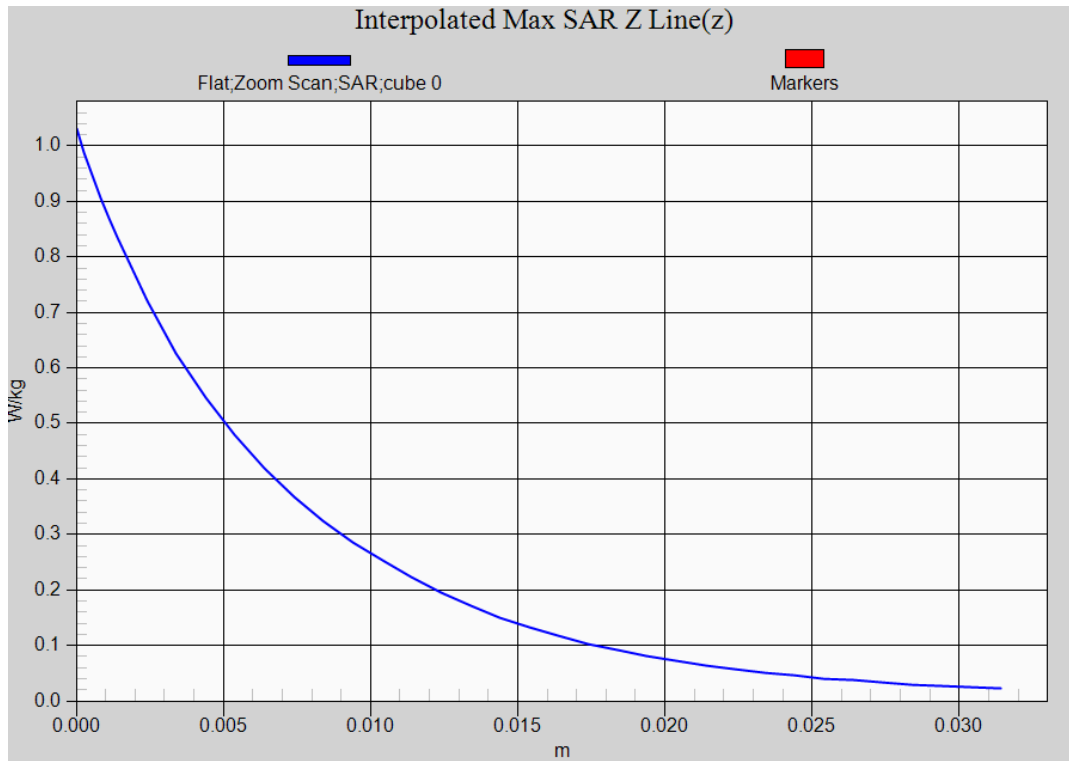

Test Laboratory: DEKRA

Date: 2022/03/09

20_LTE_Band41_QPSK_20M_39750_1RB-50_Bottom-Speed_0mm-PC2

DUT: 7c Modular Platform; Type: QSIP7180

Communication System: UID 0, FCC LTE-TDD Band 41; Frequency: 2506 MHz;

Communication System PAR: 2.331 dB

Medium parameters used: $f = 2506$ MHz; $\sigma = 1.89$ S/m; $\epsilon_r = 40.11$; $\rho = 1000$ kg/m³

Phantom section: Flat Section

Ambient Temperature (°C) : 23.1, Liquid Temperature (°C) : 22.3

Measurement Standard: DASYS (IEEE/IEC/ANSI C63.19-2011)

DASY5 Configuration:

- Probe: EX3DV4 - SN3698; ConvF(6.97, 6.97, 6.97); Calibrated: 2021/11/24;
- Sensor-Surface: 1.4mm (Mechanical Surface Detection)
- Electronics: DAE4 Sn1207; Calibrated: 2021/11/22
- Phantom: SAM with left table; Type: SAM;
- Measurement SW: DASYS2, Version 52.10 (0); SEMCAD X Version 14.6.10 (7417)

Configuration/Flat/Area Scan (11x12x1): Measurement grid: dx=12mm, dy=12mm

Maximum value of SAR (measured) = 1.31 W/kg

Configuration/Flat/Zoom Scan (7x7x7)/Cube 0: Measurement grid: dx=5mm, dy=5mm, dz=5mm

Reference Value = 16.07 V/m; Power Drift = 0.04 dB

Peak SAR (extrapolated) = 1.73 W/kg

SAR(1 g) = 0.885 W/kg; SAR(10 g) = 0.478 W/kg

Maximum value of SAR (measured) = 1.40 W/kg

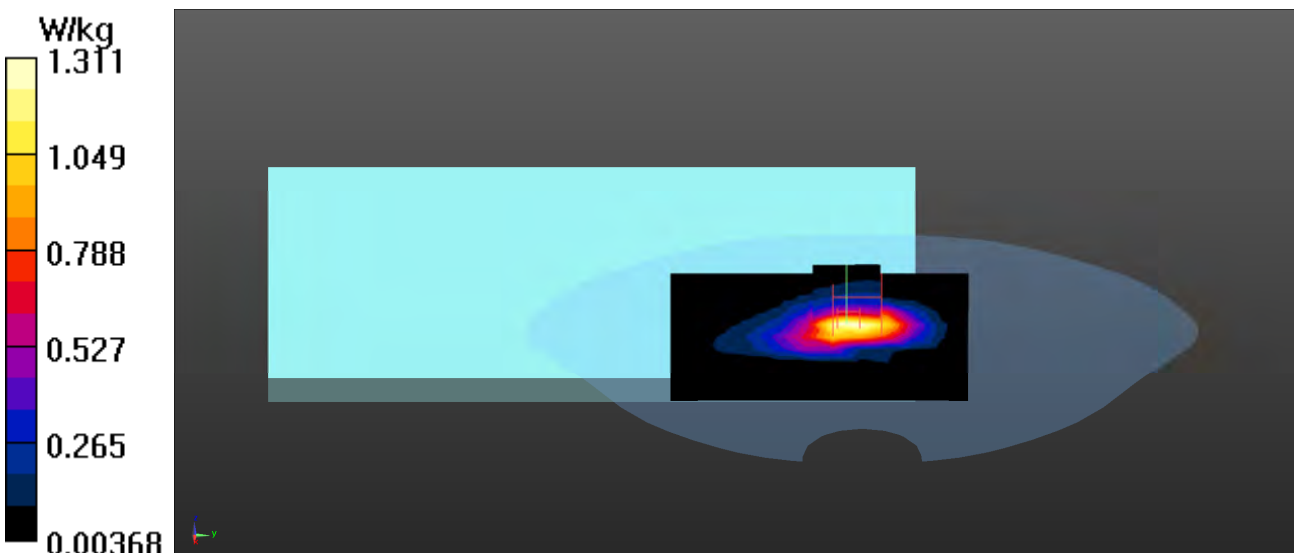

LTE Band 41_QPSK 20M 1RB-50 Bottom (Speed 0mm-PC2) Z-Axis plot

Channel: 39750

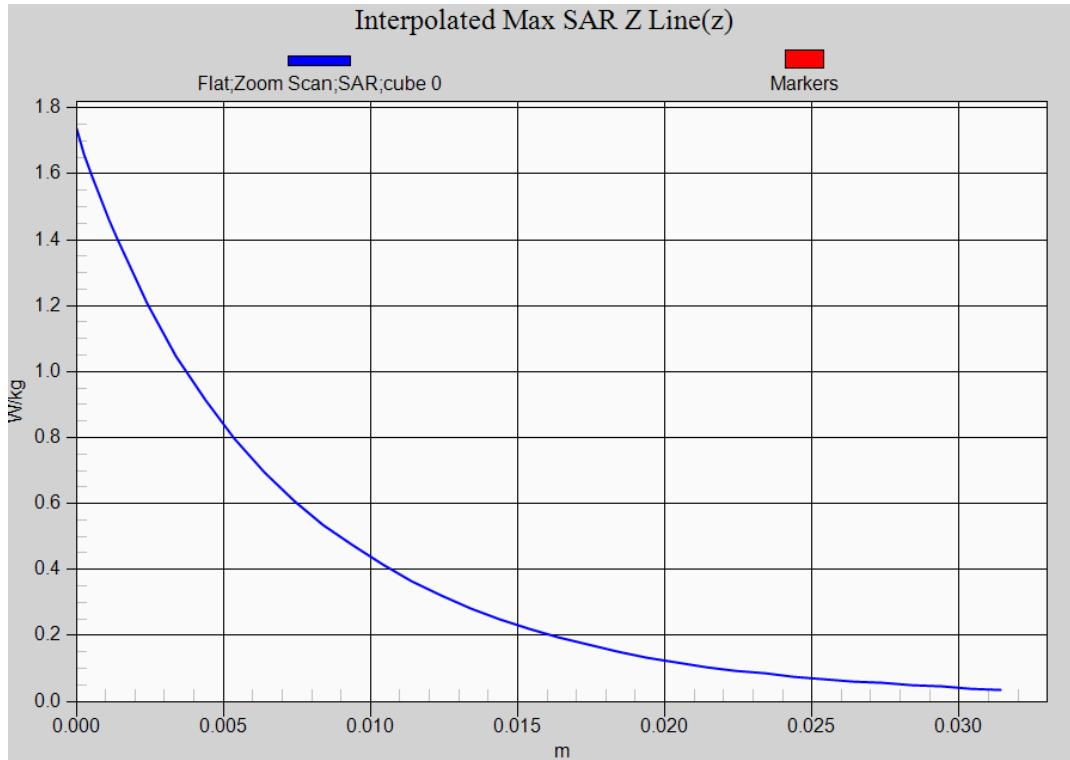

Test Laboratory: DEKRA

Date: 2022/02/23

21_LTE_Band66_QPSK_20M_132572_1RB-0_Bottom-Speed_0mm**DUT: 7c Modular Platform; Type: QSIP7180**

Communication System: UID 0, FCC LTE Band66; Frequency: 1770 MHz;

Communication System PAR: 0 dB

Medium parameters used: $f = 1770$ MHz; $\sigma = 1.36$ S/m; $\epsilon_r = 40.27$; $\rho = 1000$ kg/m³

Phantom section: Flat Section

Ambient Temperature (°C) : 23.1, Liquid Temperature (°C) : 22.4

Measurement Standard: DASY5 (IEEE/IEC/ANSI C63.19-2011)

DASY5 Configuration:

- Probe: EX3DV4 - SN3698; ConvF(7.96, 7.96, 7.96); Calibrated: 2021/11/24;
- Sensor-Surface: 1.4mm (Mechanical Surface Detection)
- Electronics: DAE4 Sn1207; Calibrated: 2021/11/22
- Phantom: SAM with left table; Type: SAM;
- Measurement SW: DASY52, Version 52.10 (0); SEMCAD X Version 14.6.10 (7417)

Configuration/Flat/Area Scan (9x10x1): Measurement grid: dx=15mm, dy=15mm

Maximum value of SAR (measured) = 0.856 W/kg

Configuration/Flat/Zoom Scan (5x5x7)/Cube 0: Measurement grid: dx=8mm, dy=8mm, dz=5mm

Reference Value = 12.95 V/m; Power Drift = 0.02 dB

Peak SAR (extrapolated) = 1.10 W/kg

SAR(1 g) = 0.595 W/kg; SAR(10 g) = 0.329 W/kg

Maximum value of SAR (measured) = 0.885 W/kg

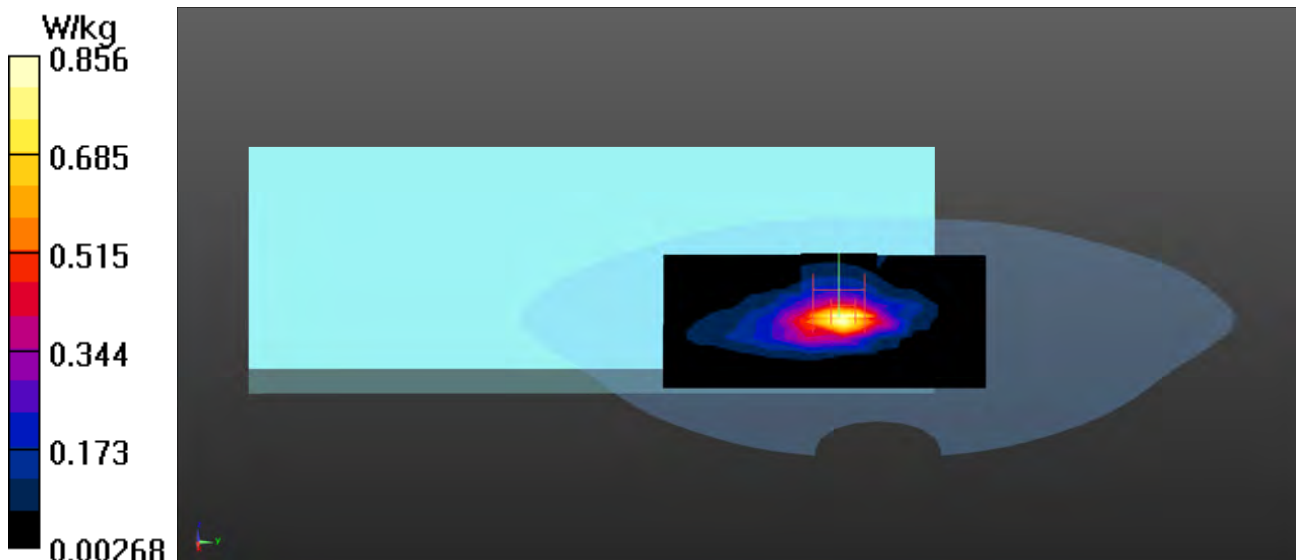

LTE Band 66 QPSK 20M 1RB-0 Bottom (Speed_0mm) Z-Axis plot

Channel: 132072

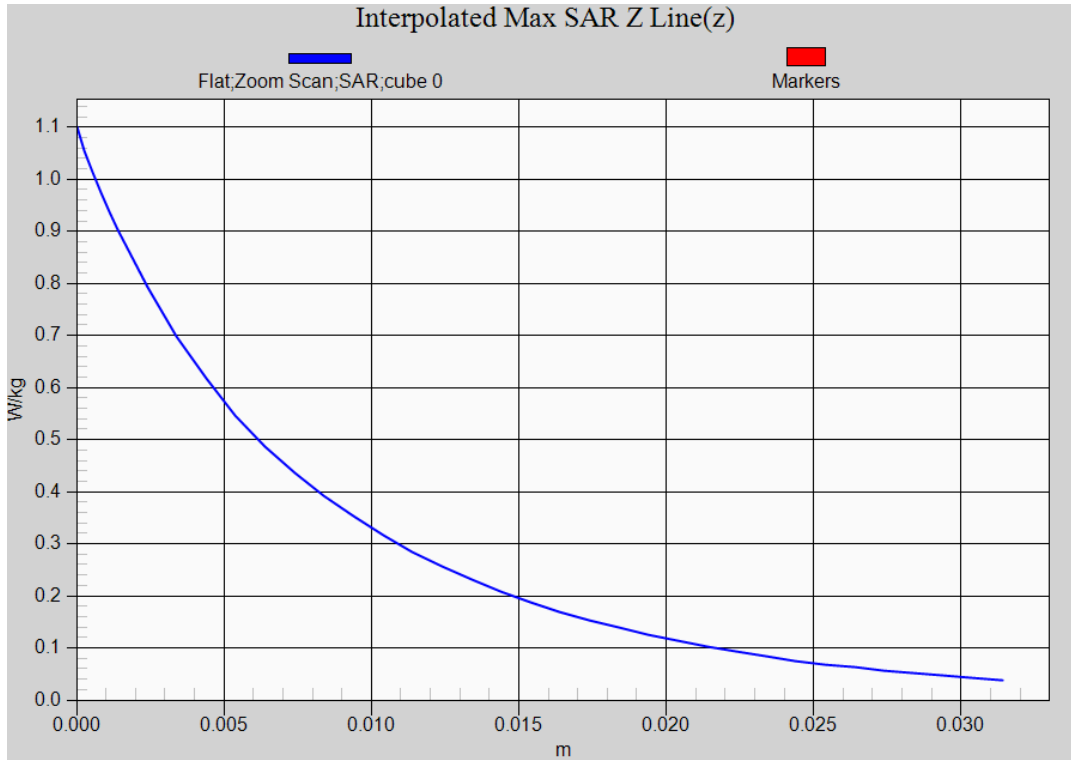

Test Laboratory: DEKRA

Date: 2022/03/08

22_LTE_Band71_QPSK_20M_133222_1RB-50_Bottom-Speed_0mm**DUT: 7c Modular Platform; Type: QSIP7180**

Communication System: UID 0, LTE B71; Frequency: 673 MHz;

Communication System PAR: 0 dB

Medium parameters used: $f = 673$ MHz; $\sigma = 0.86$ S/m; $\epsilon_r = 42.93$; $\rho = 1000$ kg/m³

Phantom section: Flat Section

Ambient Temperature (°C) : 23.3, Liquid Temperature (°C) : 22.1

Measurement Standard: DASY5 (IEEE/IEC/ANSI C63.19-2011)

DASY5 Configuration:

- Probe: EX3DV4 - SN3698; ConvF(9.1, 9.1, 9.1); Calibrated: 2021/11/24;
- Sensor-Surface: 1.4mm (Mechanical Surface Detection)
- Electronics: DAE4 Sn1207; Calibrated: 2021/11/22
- Phantom: SAM with left table; Type: SAM;
- Measurement SW: DASY52, Version 52.10 (0); SEMCAD X Version 14.6.10 (7417)

Configuration/Flat/Area Scan (9x10x1): Measurement grid: dx=15mm, dy=15mm

Maximum value of SAR (measured) = 0.905 W/kg

Configuration/Flat/Zoom Scan (5x5x7)/Cube 0: Measurement grid: dx=8mm, dy=8mm, dz=5mm

Reference Value = 27.53 V/m; Power Drift = 0.02 dB

Peak SAR (extrapolated) = 1.13 W/kg

SAR(1 g) = 0.691 W/kg; SAR(10 g) = 0.436 W/kg

Maximum value of SAR (measured) = 0.962 W/kg

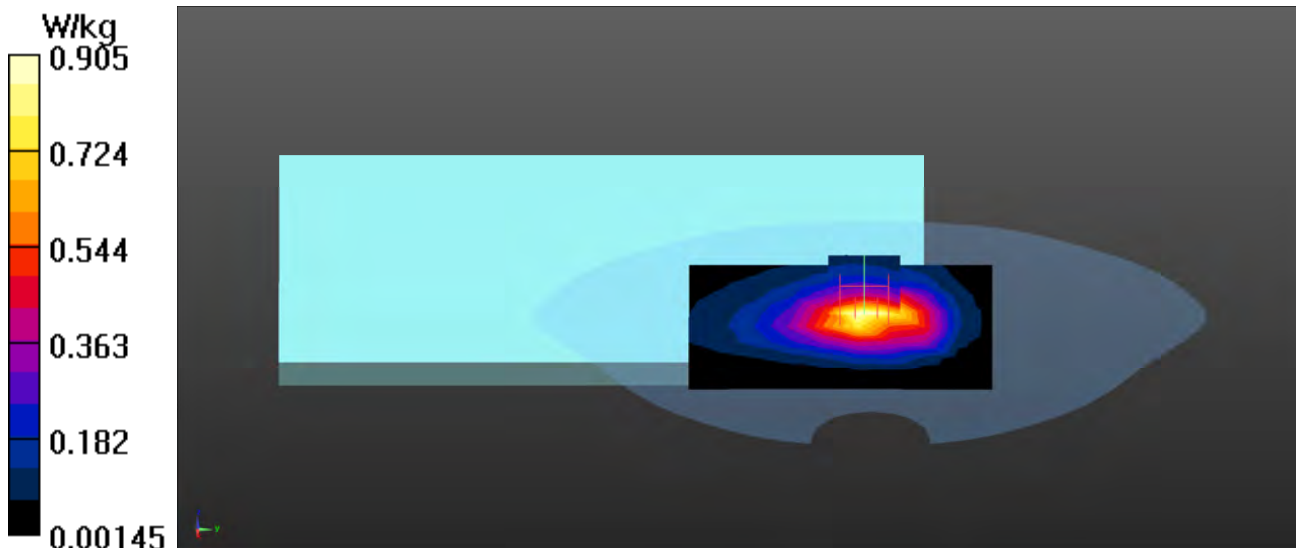

LTE Band 71_QPSK 20M 1RB-50 Bottom (Speed 0mm) Z-Axis plot

Channel: 133222

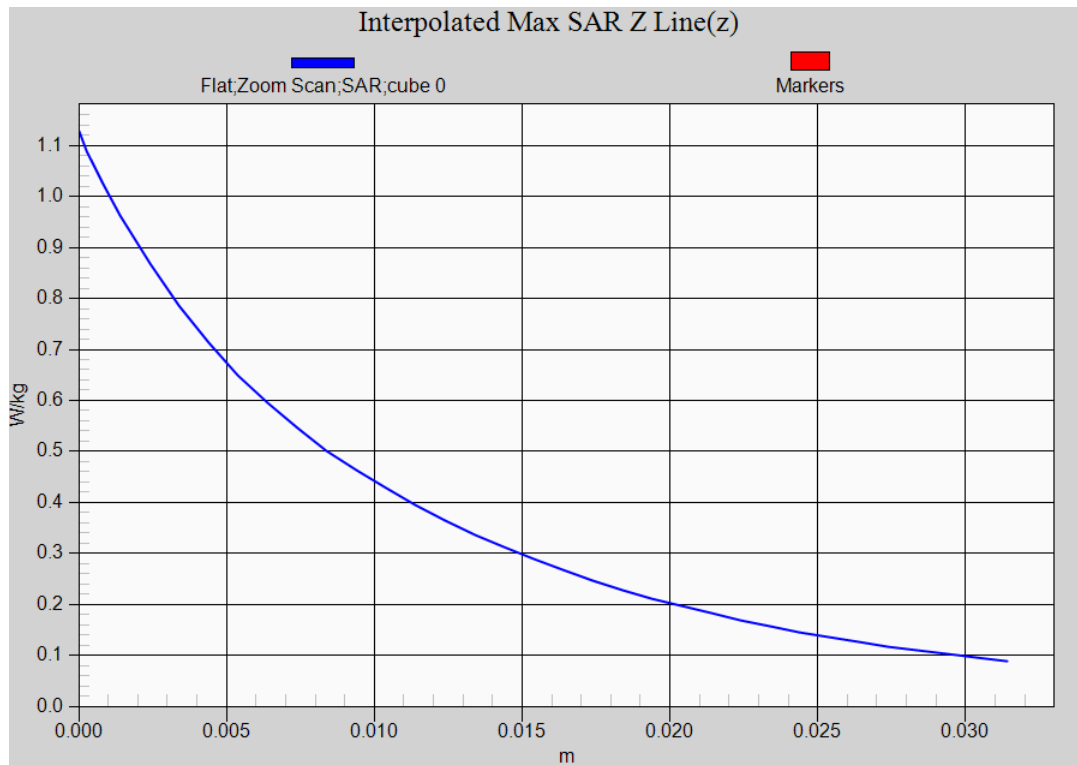



Appendix D. Probe Calibration



Accredited by the Swiss Accreditation Service (SAS)
The Swiss Accreditation Service is one of the signatories to the EA
Multilateral Agreement for the recognition of calibration certificates

Accreditation No.: **SCS 0108**

Client **DEKRA (Auden)**

Certificate No: **EX3-3698_Nov21**

CALIBRATION CERTIFICATE

Object: **EX3DV4 - SN:3698**

Calibration procedure(s): **QA CAL-01.v9, QA CAL-12.v9, QA CAL-14.v6, QA CAL-23.v5, QA CAL-25.v7
Calibration procedure for dosimetric E-field probes**

Calibration date: **November 24, 2021**

This calibration certificate documents the traceability to national standards, which realize the physical units of measurements (SI). The measurements and the uncertainties with confidence probability are given on the following pages and are part of the certificate.

All calibrations have been conducted in the closed laboratory facility: environment temperature (22 ± 3)°C and humidity < 70%.

Calibration Equipment used (M&TE critical for calibration)

Primary Standards	ID	Cal Date (Certificate No.)	Scheduled Calibration
Power meter NRP	SN: 104778	09-Apr-21 (No. 217-03291/03292)	Apr-22
Power sensor NRP-Z91	SN: 103244	09-Apr-21 (No. 217-03291)	Apr-22
Power sensor NRP-Z91	SN: 103245	09-Apr-21 (No. 217-03292)	Apr-22
Reference 20 dB Attenuator	SN: CC2552 (20x)	09-Apr-21 (No. 217-03343)	Apr-22
DAE4	SN: 660	23-Dec-20 (No. DAE4-660_Dec20)	Dec-21
Reference Probe ES3DV2	SN: 3013	30-Dec-20 (No. ES3-3013_Dec20)	Dec-21
Secondary Standards	ID	Check Date (in house)	Scheduled Check
Power meter E4419B	SN: GB41293874	06-Apr-16 (in house check Jun-20)	In house check: Jun-22
Power sensor E4412A	SN: MY41498087	06-Apr-16 (in house check Jun-20)	In house check: Jun-22
Power sensor E4412A	SN: 000110210	06-Apr-16 (in house check Jun-20)	In house check: Jun-22
RF generator HP 8648C	SN: US3642U01700	04-Aug-99 (in house check Jun-20)	In house check: Jun-22
Network Analyzer E8358A	SN: US41080477	31-Mar-14 (in house check Oct-20)	In house check: Oct-22

	Name	Function	Signature
Calibrated by:	Jeton Kastrati	Laboratory Technician	
Approved by:	Niels Kuster	Quality Manager	

Issued: November 26, 2021

This calibration certificate shall not be reproduced except in full without written approval of the laboratory.



Accredited by the Swiss Accreditation Service (SAS)

Accreditation No.: **SCS 0108**

The Swiss Accreditation Service is one of the signatories to the EA
Multilateral Agreement for the recognition of calibration certificates

Glossary:

TSL	tissue simulating liquid
NORM _{x,y,z}	sensitivity in free space
ConvF	sensitivity in TSL / NORM _{x,y,z}
DCP	diode compression point
CF	crest factor (1/duty_cycle) of the RF signal
A, B, C, D	modulation dependent linearization parameters
Polarization φ	φ rotation around probe axis
Polarization ϑ	ϑ rotation around an axis that is in the plane normal to probe axis (at measurement center), i.e., ϑ = 0 is normal to probe axis
Connector Angle	information used in DASY system to align probe sensor X to the robot coordinate system

Calibration is Performed According to the Following Standards:

- a) IEC/IEEE 62209-1528, "Measurement Procedure For The Assessment Of Specific Absorption Rate Of Human Exposure To Radio Frequency Fields From Hand-Held And Body-Worn Wireless Communication Devices - Part 1528: Human Models, Instrumentation And Procedures (Frequency Range of 4 MHz to 10 GHz)", October 2020.
- b) KDB 865664, "SAR Measurement Requirements for 100 MHz to 6 GHz"

Methods Applied and Interpretation of Parameters:

- *NORM_{x,y,z}*: Assessed for E-field polarization ϑ = 0 (f ≤ 900 MHz in TEM-cell; f > 1800 MHz: R22 waveguide). *NORM_{x,y,z}* are only intermediate values, i.e., the uncertainties of *NORM_{x,y,z}* does not affect the E²-field uncertainty inside TSL (see below *ConvF*).
- *NORM(f)_{x,y,z}* = *NORM_{x,y,z}* * *frequency_response* (see Frequency Response Chart). This linearization is implemented in DASY4 software versions later than 4.2. The uncertainty of the frequency response is included in the stated uncertainty of *ConvF*.
- *DCP_{x,y,z}*: DCP are numerical linearization parameters assessed based on the data of power sweep with CW signal (no uncertainty required). DCP does not depend on frequency nor media.
- *PAR*: *PAR* is the Peak to Average Ratio that is not calibrated but determined based on the signal characteristics
- *A_{x,y,z}*; *B_{x,y,z}*; *C_{x,y,z}*; *D_{x,y,z}*; *VR_{x,y,z}*; *A, B, C, D* are numerical linearization parameters assessed based on the data of power sweep for specific modulation signal. The parameters do not depend on frequency nor media. *VR* is the maximum calibration range expressed in RMS voltage across the diode.
- *ConvF* and *Boundary Effect Parameters*: Assessed in flat phantom using E-field (or Temperature Transfer Standard for f ≤ 800 MHz) and inside waveguide using analytical field distributions based on power measurements for f > 800 MHz. The same setups are used for assessment of the parameters applied for boundary compensation (alpha, depth) of which typical uncertainty values are given. These parameters are used in DASY4 software to improve probe accuracy close to the boundary. The sensitivity in TSL corresponds to *NORM_{x,y,z}* * *ConvF* whereby the uncertainty corresponds to that given for *ConvF*. A frequency dependent *ConvF* is used in DASY version 4.4 and higher which allows extending the validity from ± 50 MHz to ± 100 MHz.
- *Spherical isotropy (3D deviation from isotropy)*: in a field of low gradients realized using a flat phantom exposed by a patch antenna.
- *Sensor Offset*: The sensor offset corresponds to the offset of virtual measurement center from the probe tip (on probe axis). No tolerance required.
- *Connector Angle*: The angle is assessed using the information gained by determining the *NORM_x* (no uncertainty required).

DASY/EASY - Parameters of Probe: EX3DV4 - SN:3698

Basic Calibration Parameters

	Sensor X	Sensor Y	Sensor Z	Unc (k=2)
Norm ($\mu\text{V}/(\text{V}/\text{m})^2$) ^A	0.41	0.34	0.37	$\pm 10.1\%$
DCP (mV) ^B	105.0	101.0	105.0	

Calibration Results for Modulation Response

UID	Communication System Name		A dB	B dB $\sqrt{\mu\text{V}}$	C	D dB	VR mV	Max dev.	Unc ^E (k=2)
0	CW	X	0.0	0.0	1.0	0.00	147.1	$\pm 3.3\%$	$\pm 4.7\%$
		Y	0.0	0.0	1.0		129.5		
		Z	0.0	0.0	1.0		141.3		

The reported uncertainty of measurement is stated as the standard uncertainty of measurement multiplied by the coverage factor $k=2$, which for a normal distribution corresponds to a coverage probability of approximately 95%.

^A The uncertainties of Norm X,Y,Z do not affect the E²-field uncertainty inside TSL (see Page 5).

^B Numerical linearization parameter: uncertainty not required.

^E Uncertainty is determined using the max. deviation from linear response applying rectangular distribution and is expressed for the square of the field value.

DASY/EASY - Parameters of Probe: EX3DV4 - SN:3698

Other Probe Parameters

Sensor Arrangement	Triangular
Connector Angle (°)	-137
Mechanical Surface Detection Mode	enabled
Optical Surface Detection Mode	disabled
Probe Overall Length	337 mm
Probe Body Diameter	10 mm
Tip Length	9 mm
Tip Diameter	2.5 mm
Probe Tip to Sensor X Calibration Point	1 mm
Probe Tip to Sensor Y Calibration Point	1 mm
Probe Tip to Sensor Z Calibration Point	1 mm
Recommended Measurement Distance from Surface	1.4 mm

Note: Measurement distance from surface can be increased to 3-4 mm for an *Area Scan* job.

DASY/EASY - Parameters of Probe: EX3DV4 - SN:3698

Calibration Parameter Determined in Head Tissue Simulating Media

f (MHz) ^c	Relative Permittivity ^F	Conductivity (S/m) ^F	ConvF X	ConvF Y	ConvF Z	Alpha ^G	Depth ^G (mm)	Unc (k=2)
450	43.5	0.87	9.73	9.73	9.73	0.16	1.30	± 13.3 %
750	41.9	0.89	9.10	9.10	9.10	0.46	0.80	± 12.0 %
835	41.5	0.90	8.90	8.90	8.90	0.38	0.96	± 12.0 %
900	41.5	0.97	8.81	8.81	8.81	0.47	0.80	± 12.0 %
1450	40.5	1.20	8.18	8.18	8.18	0.58	0.80	± 12.0 %
1640	40.2	1.31	8.08	8.08	8.08	0.30	0.86	± 12.0 %
1750	40.1	1.37	7.96	7.96	7.96	0.28	0.86	± 12.0 %
1950	40.0	1.40	7.60	7.60	7.60	0.39	0.86	± 12.0 %
2300	39.5	1.67	7.39	7.39	7.39	0.33	0.90	± 12.0 %
2450	39.2	1.80	7.19	7.19	7.19	0.27	0.90	± 12.0 %
2600	39.0	1.96	6.97	6.97	6.97	0.36	0.90	± 12.0 %
3300	38.2	2.71	6.65	6.65	6.65	0.30	1.35	± 13.1 %
3500	37.9	2.91	6.30	6.30	6.30	0.35	1.30	± 13.1 %
3700	37.7	3.12	6.15	6.15	6.15	0.35	1.30	± 13.1 %
5250	35.9	4.71	4.70	4.70	4.70	0.40	1.80	± 13.1 %
5600	35.5	5.07	4.35	4.35	4.35	0.40	1.80	± 13.1 %
5800	35.3	5.27	4.58	4.58	4.58	0.40	1.80	± 13.1 %

^c Frequency validity above 300 MHz of ± 100 MHz only applies for DASY v4.4 and higher (see Page 2), else it is restricted to ± 50 MHz. The uncertainty is the RSS of the ConvF uncertainty at calibration frequency and the uncertainty for the indicated frequency band. Frequency validity below 300 MHz is ± 10, 25, 40, 50 and 70 MHz for ConvF assessments at 30, 64, 128, 150 and 220 MHz respectively. Validity of ConvF assessed at 6 MHz is 4-9 MHz, and ConvF assessed at 13 MHz is 9-19 MHz. Above 5 GHz frequency validity can be extended to ± 110 MHz.

^F At frequencies below 3 GHz, the validity of tissue parameters (ϵ and σ) can be relaxed to ± 10% if liquid compensation formula is applied to measured SAR values. At frequencies above 3 GHz, the validity of tissue parameters (ϵ and σ) is restricted to ± 5%. The uncertainty is the RSS of the ConvF uncertainty for indicated target tissue parameters.

^G Alpha/Depth are determined during calibration. SPEAG warrants that the remaining deviation due to the boundary effect after compensation is always less than ± 1% for frequencies below 3 GHz and below ± 2% for frequencies between 3-6 GHz at any distance larger than half the probe tip diameter from the boundary.

Frequency Response of E-Field (TEM-Cell:ifi110 EXX, Waveguide: R22)

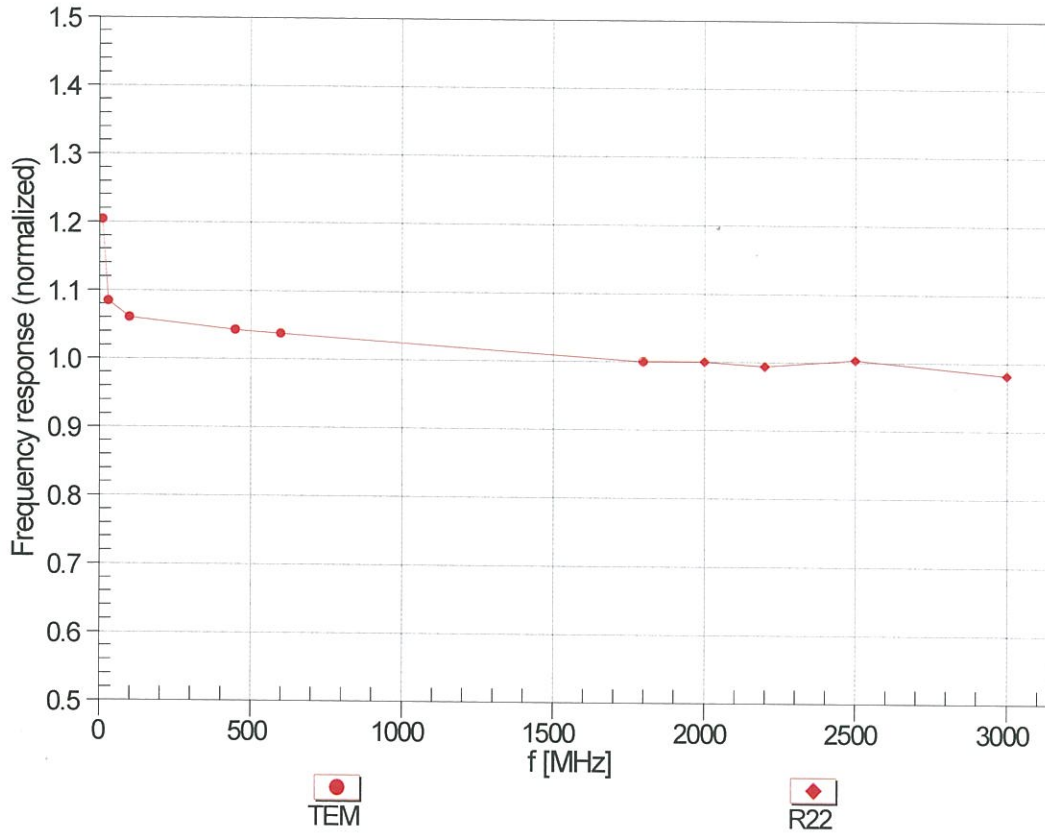

Uncertainty of Frequency Response of E-field: $\pm 6.3\%$ (k=2)

Receiving Pattern (ϕ), $\vartheta = 0^\circ$

f=600 MHz, TEM

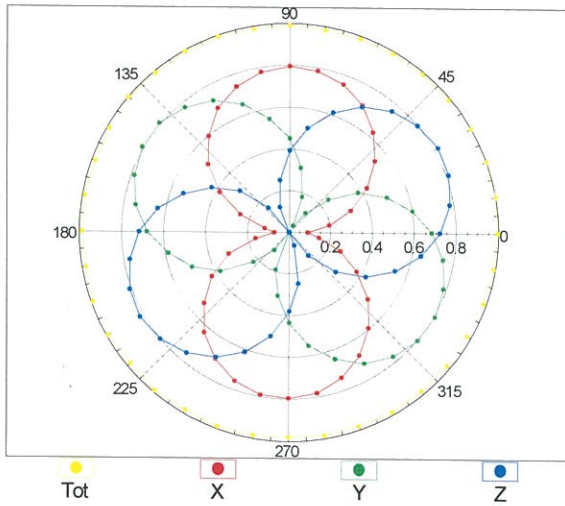

f=1800 MHz, R22

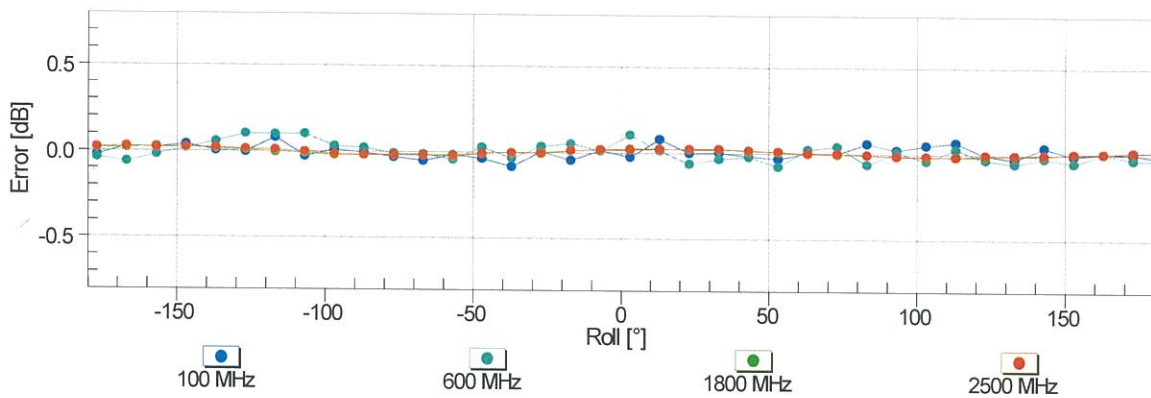
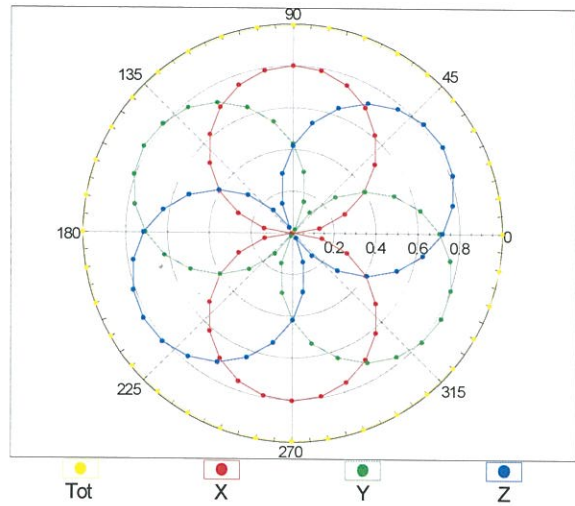

Uncertainty of Axial Isotropy Assessment: $\pm 0.5\%$ (k=2)

Dynamic Range f(SAR_{head}) (TEM cell , f_{eval}= 1900 MHz)

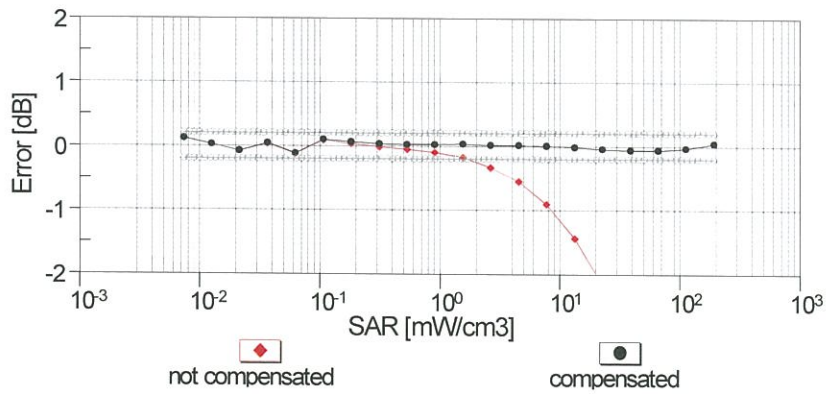
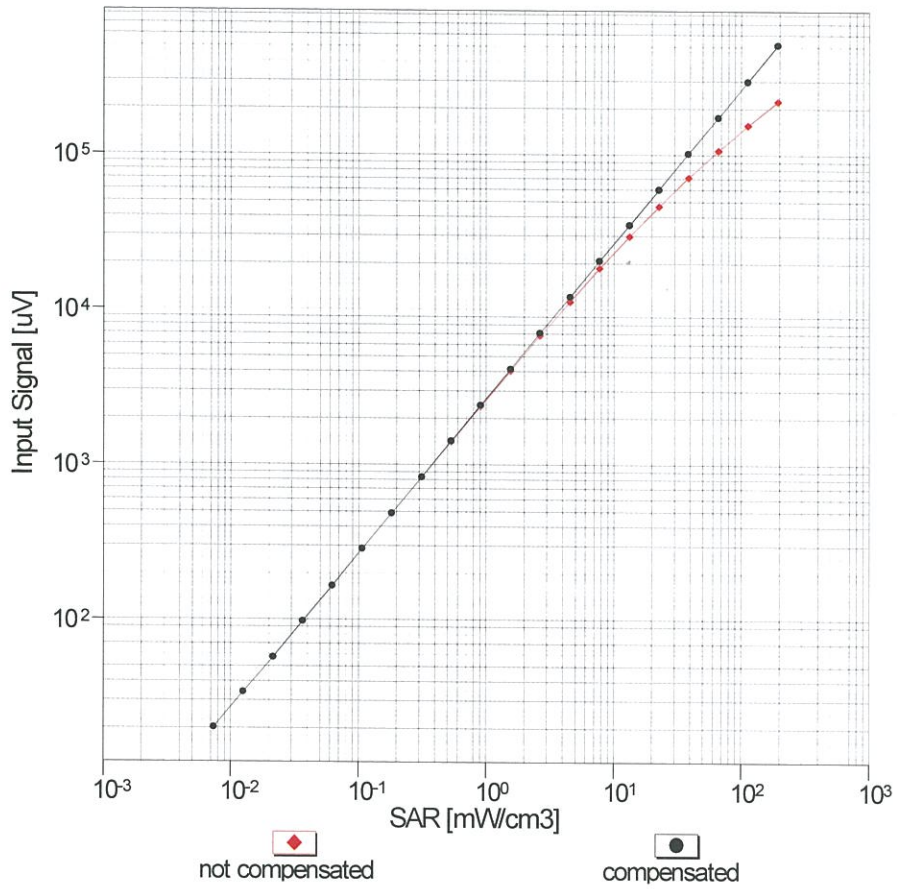

Uncertainty of Linearity Assessment: ± 0.6% (k=2)

Conversion Factor Assessment

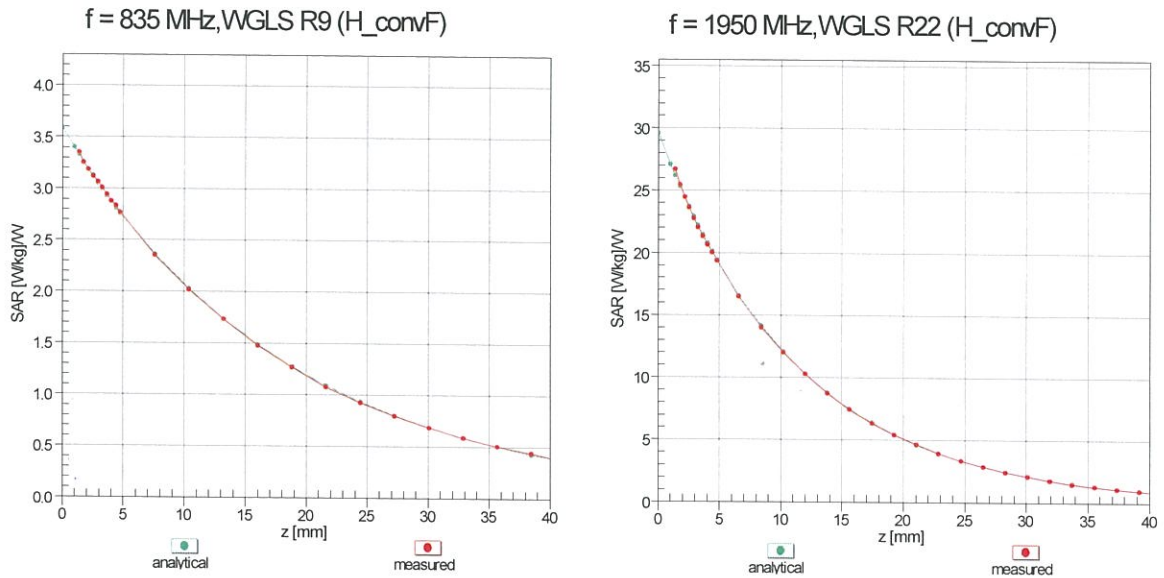

Deviation from Isotropy in Liquid Error (ϕ, θ), f = 900 MHz

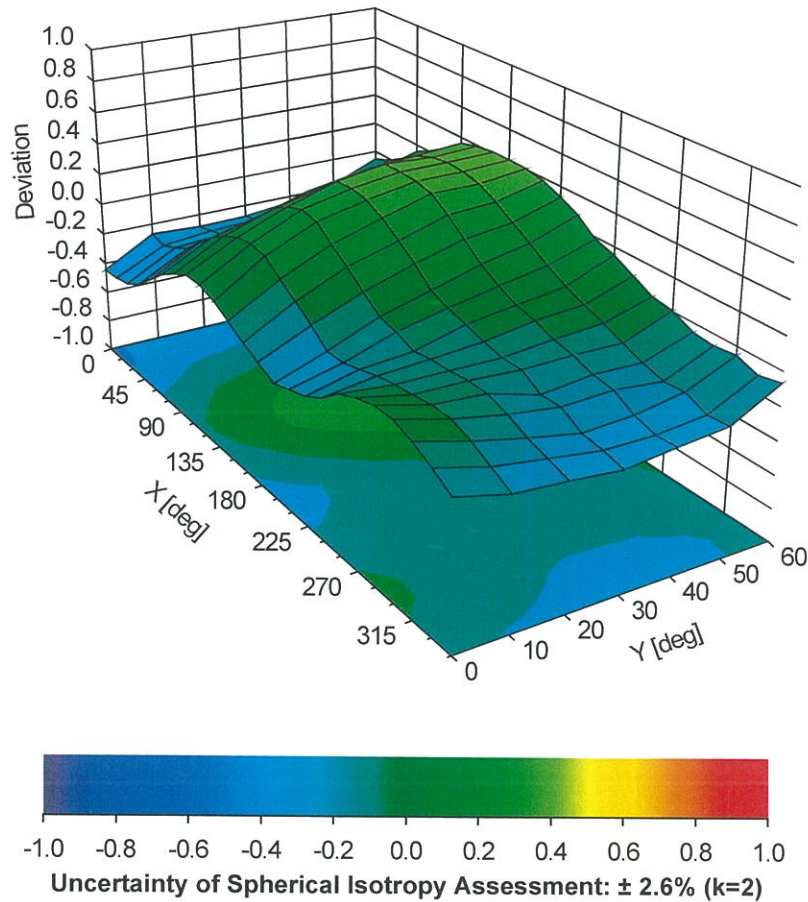



Appendix E. Dipole Calibration

Instrument	Manufacturer	Model No.	Serial No.
Reference Dipole 750MHz	Speag	D750V3	1031
Reference Dipole 1750MHz	Speag	D1750V2	1113
Reference Dipole 1950MHz	Speag	D1950V3	1213
Reference Dipole 2300MHz	Speag	D2300V2	1045
Reference Dipole 2450MHz	Speag	D2450V2	930
Reference Dipole 2600MHz	Apral	ALS-D-2600-S-2	QTK-225
Reference Dipole 5GHz	Speag	D5GHzV2	1041



Accredited by the Swiss Accreditation Service (SAS)
The Swiss Accreditation Service is one of the signatories to the EA
Multilateral Agreement for the recognition of calibration certificates

Accreditation No.: **SCS 0108**

Client **DEKRA (Auden)**

Certificate No: **D750V3-1031_May20**

CALIBRATION CERTIFICATE

Object **D750V3 - SN:1031**

Calibration procedure(s) **QA CAL-05.v11
Calibration Procedure for SAR Validation Sources between 0.7-3 GHz**

Calibration date: **May 27, 2020**

This calibration certificate documents the traceability to national standards, which realize the physical units of measurements (SI).
The measurements and the uncertainties with confidence probability are given on the following pages and are part of the certificate.

All calibrations have been conducted in the closed laboratory facility: environment temperature (22 ± 3)°C and humidity < 70%.

Calibration Equipment used (M&TE critical for calibration)

Primary Standards	ID #	Cal Date (Certificate No.)	Scheduled Calibration
Power meter NRP	SN: 104778	01-Apr-20 (No. 217-03100/03101)	Apr-21
Power sensor NRP-Z91	SN: 103244	01-Apr-20 (No. 217-03100)	Apr-21
Power sensor NRP-Z91	SN: 103245	01-Apr-20 (No. 217-03101)	Apr-21
Reference 20 dB Attenuator	SN: BH9394 (20k)	31-Mar-20 (No. 217-03106)	Apr-21
Type-N mismatch combination	SN: 310982 / 06327	31-Mar-20 (No. 217-03104)	Apr-21
Reference Probe EX3DV4	SN: 7349	31-Dec-19 (No. EX3-7349_Dec19)	Dec-20
DAE4	SN: 601	27-Dec-19 (No. DAE4-601_Dec19)	Dec-20
Secondary Standards	ID #	Check Date (in house)	Scheduled Check
Power meter E4419B	SN: GB39512475	30-Oct-14 (in house check Feb-19)	In house check: Oct-20
Power sensor HP 8481A	SN: US37292783	07-Oct-15 (in house check Oct-18)	In house check: Oct-20
Power sensor HP 8481A	SN: MY41092317	07-Oct-15 (in house check Oct-18)	In house check: Oct-20
RF generator R&S SMT-06	SN: 100972	15-Jun-15 (in house check Oct-18)	In house check: Oct-20
Network Analyzer Agilent E8358A	SN: US41080477	31-Mar-14 (in house check Oct-19)	In house check: Oct-20

Calibrated by:	Name Jeffrey Katzman	Function Laboratory Technician	Signature
Approved by:	Name Katja Pokovic	Technical Manager	

Issued: May 27, 2020

This calibration certificate shall not be reproduced except in full without written approval of the laboratory.