

FCC TEST REPORT

REPORT NO.:SE08FCI141R

MODEL NO.: H508

LISTED MODELS: H501,H502,H503,H504,H505,H506,H507,H509

RECEIVED: Jul 15, 2008

TESTED: Jul 15, 2008 to Jul 21, 2008

APPLICANT: SHENZHEN XINKINGWAY TECHNOLOGY COMPANY LIMITED

ADDRESS: No.326, LiuTangRoad. Bao'an District, Shenzhen, Guangdong, China

ISSUED BY: SHENZHEN SETEK TECHNOLOGY CO., LTD.

LAB LOCATION: 2/F,A3 Bldg,East Industry Zone,Overseas Chinese Town,
Shenzhen,China

This test report consists of 63 pages in total, it may be duplicated completely for legal use with the approval of the applicant, It should not be reproduced except in full, without the written approval of our laboratory, The test results in the report only apply to the tested sample.

SHENZHEN SETEK TECHNOLOGY CO., LTD.

Our website: www.setek.com.cn

TEL:86-755-26966362

E-mail:Service@setek.com.cn

FAX: 86-755-26966270

Prepared for : SHENZHEN XINKINGWAY TECHNOLOGY COMPANY LIMITED
Address : No.326, LiuTangRoad. Bao'an District, Shenzhen, Guangdong, China
Product : BT Headset
Model No(s). : H508 (H501,H502,H503,H504,H505,H506,H507,H509)
Trademark : N/A
Test Standard : FCC Part 15 Paragraph 15.203, Paragraph 15.207 and Paragraph 15.247
Prepared by : SHENZHEN SETEK TECHNOLOGY CO., LTD.
Address : 2/F, A3 Bldg, East Industry Zone, Overseas Chinese Town, Shenzhen, China

FCC Registration Number: 966959

Tel: (86-755) 26966362 Fax:(86-755) 26966270

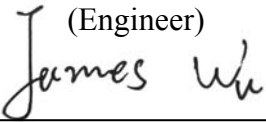
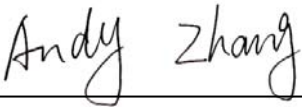
Prepared by : 
(Engineer)
Reviewer by : 
(Project Engineer)
Approved by : 
(Manager)

Report Number : SE08FCI141R
Date of Test : Jul 15, 2008 to Jul 21, 2008
Date of Report : Jul 22, 2008

The device described above is tested by SHENZHEN SETEK TECHNOLOGY CO., LTD. to determine the maximum emission levels emanating from the device and the severe levels of the device can endure and its performance criterion. This report applies to above tested sample only and shall not be reproduced in part without written approval of SHENZHEN SETEK TECHNOLOGY CO., LTD.

TABLE OF CONTENTS

Description	Page
The Report Description	
1. GENERAL INFORMATION.....	5
1.1. Description of Device (EUT).....	5
1.2. Description of test.....	6
1.3. Description of Support Device.....	7
1.4. Summary of test results.....	7
1.5. List of Measuring Equipments Used.....	8
1.6. Test Facility.....	8
1.7. Measurement Uncertainty.....	8
2. ANTENNA REQUIREMENT.....	9
2.1. Standard Applicable.....	9
2.2. Antenna Connected Construction.....	9
3. POWER LINE CONDUCTED MEASUREMENT.....	10
3.1. Test Equipment.....	10
3.2. Block Diagram of Test Setup.....	10
3.3. Power Line Conducted Emission Measurement Limits(Class B).....	10
3.4. Configuration of EUT on Measurement.....	11
3.5. Operating Condition of EUT.....	11
3.6. Test Procedure.....	11
3.7. Power Line Conducted Emission Measurement Results.....	11
4. TEST OF HOPPING CHANNEL BANDWIDTH.....	12
4.1 Applicable Standard.....	12
4.2 EUT Setup.....	12
4.3 Test Equipment List and Details.....	12
4.4 Test Procedure.....	12
4.5 Test Result.....	12
5. TEST OF HOPPING CHANNEL SEPARATION.....	16
5.1 Applicable Standard.....	16
5.2 EUT Setup.....	16
5.3 Test Equipment List and Details.....	16
5.4 Test Procedure.....	16
5.5 Test Result.....	16
6. TEST OF NUMBER OF HOPPING FREQUENCY.....	20
6.1 Applicable Standard.....	20
6.2 EUT Setup.....	20
6.3 Test Equipment List and Details.....	20
6.4 Test Procedure.....	20
6.5 Test Result.....	20
7. TEST OF DWELL TIME OF EACH FREQUENCY.....	22
7.1 Applicable Standard.....	22
7.2 EUT Setup.....	22
7.3 Test Equipment List and Details.....	22
7.4 Test Procedure.....	22
7.5 Test Result.....	22
8. TEST OF MAXIMUM PEAK OUTPUT POWER.....	31
8.1 Applicable Standard.....	31
8.2 EUT Setup.....	31

8.3 Test Equipment List and Details	31
8.4 Test Procedure.....	31
8.5 Test Result.....	32
9. TEST OF BAND EDGES EMISSION.....	35
9.1 Applicable Standard	35
9.2 EUT Setup.....	35
9.3 Test Equipment List and Details	35
9.4 Test Procedure.....	36
9.5 Test Result.....	36
10. PEAK POWER SPECTRAL DENSITY MEASUREMENT	39
10.1 Standard Applicable	39
10.2 Test Equipment List and Details	39
10.3 Measurement Procedure.....	39
10.4 Test Result.....	40
11. TEST OF SPURIOUS RADIATED EMISSION	42
11.1 Applicable Standard	42
11.2 EUT Setup.....	42
11.3 Test Equipment List and Details	43
11.4 Test Procedure.....	43
11.5 Test Result.....	44
12. FCC ID LABEL	53
13. PHOTOGRAPH.....	54
13.1 Photo of Radiated Measurement	54

APPENDIX I (Compliance Statements)

APPENDIX II (Photos of EUT)

1. GENERAL INFORMATION

1.1. Description of Device (EUT)

Applicant : SHENZHEN XINKINGWAY TECHNOLOGY COMPANY LIMITED

Address : No.326, LiuTangRoad. Bao'an District, Shenzhen, Guangdong, China

Manufacturer : SHENZHEN XINKINGWAY TECHNOLOGY COMPANY LIMITED

Address : No.326, LiuTangRoad. Bao'an District, Shenzhen, Guangdong, China

EUT : BT Headset

Model Number(s) : H508 (H501,H502,H503,H504,H505,H506,H507,H509)
(Note: The samples are the same, just colour of appearance and model names are different for the marketing requirement. We prepare H508 for the test.)

Description of EUT : BT Headset

Description of Antenna : fixed, built-in antenna -1.0dBi

Power Supply : DC 3.7 V from rechargeable battery

Operation Frequency : 2402 MHz ~ 2480 MHz

Number of Channels : 79

Type of Modulation : FHSS (DH1 GFSK/DH3 QPSK/DH5 8PPSK)

Output Power Class : Class 2

Received : Jul 15, 2008

Date of Test : Jul 15, 2008 to Jul 21, 2008

1.2.Description of test

Preliminary tests were performed in different modulation and max rate to find the worst radiated emission. Investigation has been done on all the possible configurations for searching the worst cases. The report shows the results of the worst-case with respect to the specific test item.

1.3. Description of Support Device

PC : Manufacturer: DELL
M/N: E157FPc
S/N: 53SM12X
CCC,FCC,VCCI,GS,S,CE

Monitor : Manufacturer: SAMSUNG
M/N: 710MP [R]S
S/N: MH17HVY500468F
CCC,SA,UL

Mouse : Manufacturer: DELL
M/N: M056UOA
S/N: F1101WOS
CE, VCCI,FCC,GS,UL

Keyboard : Manufacturer: DELL
M/N: SK-8135
S/N: CN-0DJ340-71616683-01U6
VCCI,CE, FCC

1.4. Summary of test results

FCC Rules	Description Of Test	Result
15.203/15.247(b)/(c)	Antenna Requirement	Pass
15.207	Conducted Emission	Pass
15.247(a)(1)	Hopping Channel Bandwidth	Pass
15.247(a)(1)	Hopping Channel Separation	Pass
15.247(a)(1)	Number of Hopping Frequency Used	Pass
15.247(a)(1)(iii)	Dwell Time of Each Frequency	Pass
15.247(b)(1)	Maximum Peak Output Power	Pass
15.247(d)	Band Edges Emission	Pass
15.247(d)	Peak Power Spectral Density	Pass
15.247(d)	Spurious Radiated Emission	Pass

1.5. List of Measuring Equipments Used

Item	Equipment	Manufacturer	Model No.	Serial No.	Last Cal.	Cal. Interval
1.	Spectrum Analyzer	Agilent	E4408B	MY44210575	May 29,2008	1 Year
2.	Test Receiver	Rohde & Schwarz	ESIB26	100234	May 29,2008	1 Year
3.	Bilog Antenna	Schwarzbeck	VULB9163	142	May 29,2008	1 Year
4.	Loop Antenna	EMCO	6502	00042960	May 29,2008	1 Year
5.	50 Coaxial Switch	Anritsu Corp	MP59B	6100237248	May 29,2008	1 Year
6.	Cable	Schwarzbeck	AK9513(1m)	CR RX2	May 29,2008	1 Year
7.	Cable	Schwarzbeck	AK9513(10m)	AC RX1	May 29,2008	1 Year
8.	Cable	Rosenberger	N/A(6m)	CR RX1	May 29,2008	1 Year
9.	Cable	Rosenberger	N/A(10m)	FP2RX2	May 29,2008	1 Year
9.	DC Power Filter	MPE	23872C	N/A	May 29,2008	1 Year
10.	Single Phase Power Line Filter	MPE	23332C	N/A	May 29,2008	1 Year
11.	3 Phase Power Line Filter	MPE	23333C	N/A	May 29,2008	1 Year
12.	Signal Generator	HP	8648A	3625U00573	May 29,2008	1 Year
13.	Test Receiver	Rohde & Schwarz	ESCS30	100350	May 29,2008	1 Year
14.	L.I.S.N.	Rohde & Schwarz	ESH2-Z5	834549/005	May 29,2008	1 Year
15.	Pulse Limiter	Rohde & Schwarz	ESH3-Z2	100006	May 29,2008	1 Year
16.	RF Cable	FUJIKURA	RG-55/U	LISN Cable	May 29,2008	1 Year
17.	Spectrum Analyzer	Agilent	E4446A	MY43360126	May 29,2008	1 Year
18.	Spectrum Analyzer	Agilent	E7405A	US41160416	May 29,2008	1 Year

1.6. Test Facility

The test facility is recognized, certified, or accredited by the following organizations:

FCC – Registration No.: 966959

SHENZHEN SETEK TECHNOLOGY CO., LTD, the EMC Laboratory has been registered and fully described in a report filed with the (FCC) Federal Communications Commission.

1.7. Measurement Uncertainty

Radiation Uncertainty : $U_r = \pm 3.84\text{dB}$

Conduction Uncertainty : $U_c = \pm 2.72\text{dB}$

2. ANTENNA REQUIREMENT

2.1. Standard Applicable

Section 15.203:

An intentional radiator shall be designed to ensure that no antenna other than that furnished by the responsible party shall be used with the device. The use of a permanently attached antenna or of an antenna that uses a unique coupling to the intentional radiator shall be considered sufficient to comply with the provisions of this Section. The manufacturer may design the unit so that a broken antenna can be replaced by the user, but the use of a standard antenna James or electrical connector is prohibited.

Section 15.247(b)/(c):

If transmitting antennas of directional gain greater than 6 dBi are used, the peak output power from the intentional radiator shall be reduced by the amount in dB that the directional gain of the antenna exceeds 6 dBi.

If the intentional radiator is used exclusively for fixed, point-to-point operations may employ transmitting antennas with directional gain greater than 6 dBi provided the maximum peak output power of the intentional radiator is reduced by 1 dB for every 3 dB that the directional gain of the antenna exceeds 6 dBi.

2.2. Antenna Connected Construction

The antenna connector is designed with permanent attachment and no consideration of replacement.

3. POWER LINE CONDUCTED MEASUREMENT

3.1. Test Equipment

See section 1.4.

3.2. Block Diagram of Test Setup

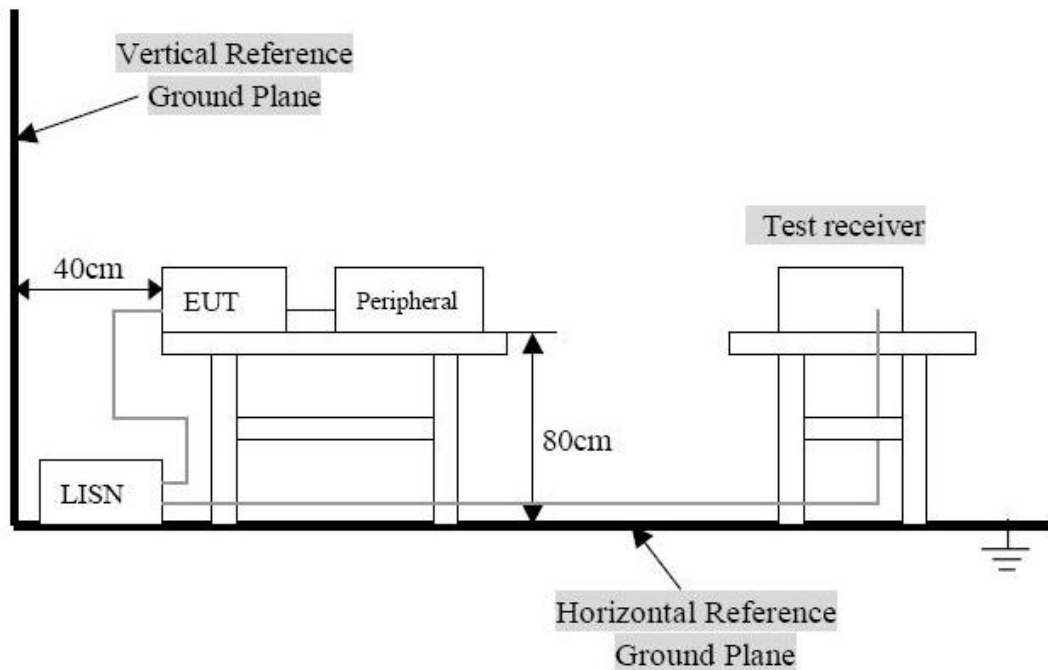

Remark: 1. The setup of EUT is according with per ANSI C63.4-2003 measurement procedure.
The specification used was with the FCC 15.207 limits.

3.3. Power Line Conducted Emission Measurement Limits(Class B)

Frequency MHz	Limits dB(μ V)	
	Quasi-peak Level	Average Level
0.15 ~ 0.50	66 ~ 56*	56 ~ 46*
0.50 ~ 5.00	56	46
5.00 ~ 30.00	60	50

Notes: 1. *Decreasing linearly with logarithm of frequency.
2. The lower limit shall apply at the transition frequencies.

3.4. Configuration of EUT on Measurement

The following equipments are installed on Power Line Conducted Emission Measurement to meet the commission requirement and operating regulations in a manner, which tends to maximize its emission characteristics in a normal application.

EUT	BT Headset
Model Number	H508

3.5. Operating Condition of EUT

- 3.5.1. Setup the EUT and simulator as shown as Section 2.2.
- 3.5.2. Turn on the power of all equipment.
- 3.5.3. Let the EUT work in test mode (Normal) and measure it.

3.6. Test Procedure

The EUT system is connected to the power mains through a line impedance stabilization network (L.I.S.N.). This provides 50ohm-coupling impedance for the EUT system. Please refer the block diagram of the test setup and photographs. Both sides of AC line are checked to find out the maximum conducted emission. In order to find the maximum emission levels, the relative positions of equipment and all of the interface cables shall be changed according to ANSI C63.4-2003 on Conducted Emission Measurement.

The bandwidth of test receiver (R & S ESCS30) is set at 9KHz.

The frequency range from 150KHz to 30 MHz is investigated.

3.7. Power Line Conducted Emission Measurement Results

N/A

Remark: N/A (not performed, BT transmitter deactivated during charging)

4. TEST OF HOPPING CHANNEL BANDWIDTH

4.1 Applicable Standard

Section 15.247(a)(1): Frequency hopping systems shall have hopping channel carrier frequencies separated by a minimum of 25 kHz or the 20 dB bandwidth of the hopping channel, whichever is greater.

4.2 EUT Setup

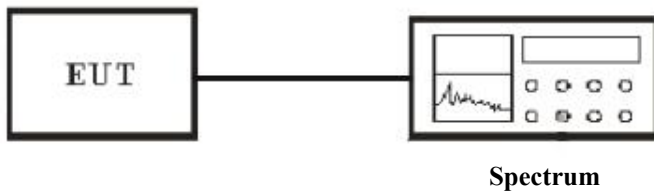

4.3 Test Equipment List and Details

See section 1.4.

4.4 Test Procedure

1. The transmitter output was connected to the spectrum analyzer through an attenuator.
2. Set RBW of spectrum analyzer to 3MHz and VBW to 3MHz.
3. Set Detector to Peak, Trace to Max Hold and Sweep Time is Auto.
4. The spectrum width with level higher than 20dB below the peak level.
5. Repeat above 1~3 points for the middle and highest channel of the EUT.

4.5 Test Result

Temperature (°C) : 22~23	EUT: BT Headset
Humidity (%RH) : 50~54	M/N: H508
Barometric Pressure (mbar) : 950~1000	Operation Condition: Tx/Rx 8PPSK Mode
Test data: Jul 16, 2008	Test engineer: James

Channel No.	Frequency (MHz)	20dB Bandwidth (MHz)	Min. Limit (kHz)
LOW	2402	1.1	>25
MID	2441	1.18	>25
HIG	2480	1.17	>25

Channel Low :

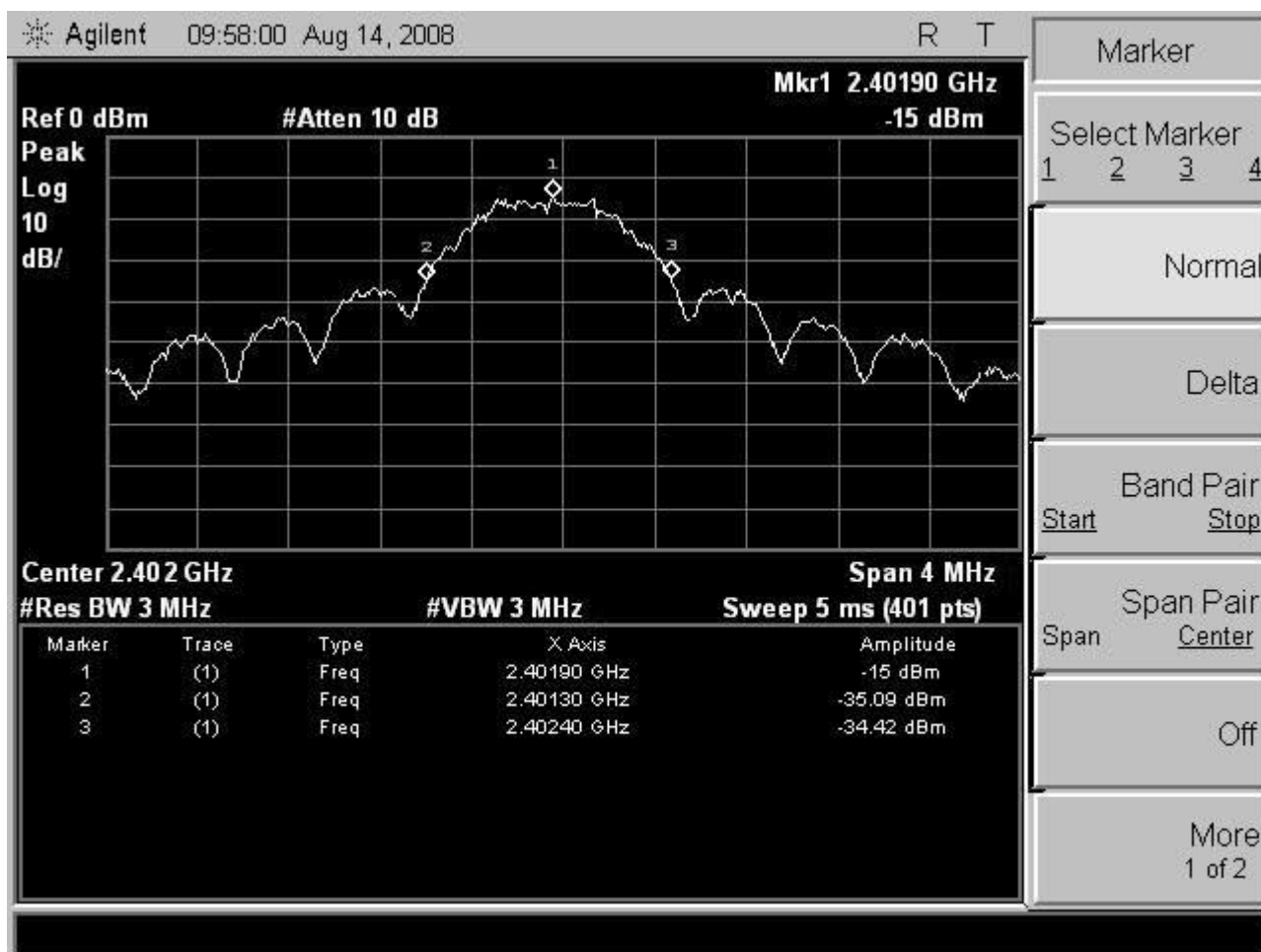

Channel MID :

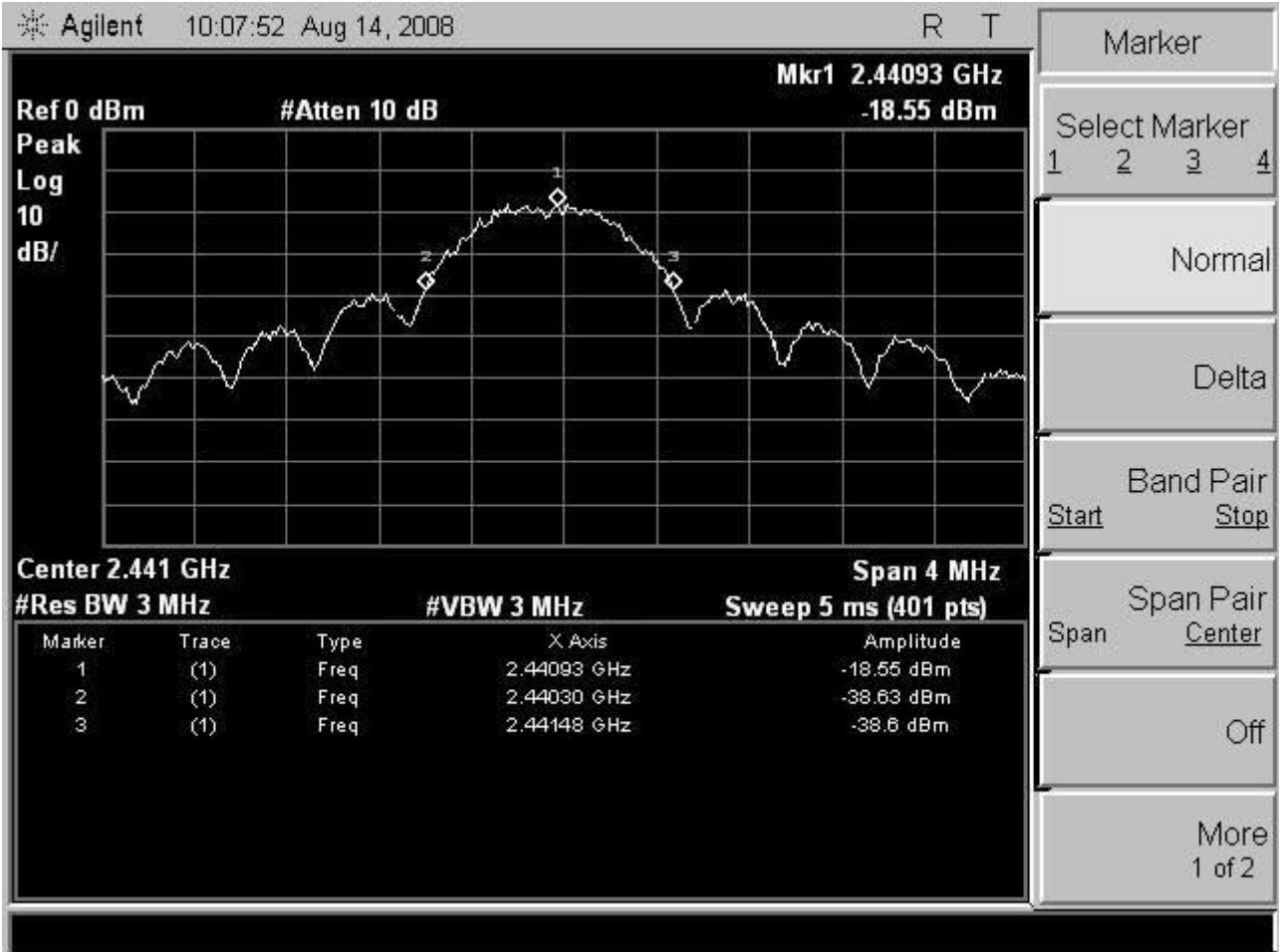

Channel HIG :

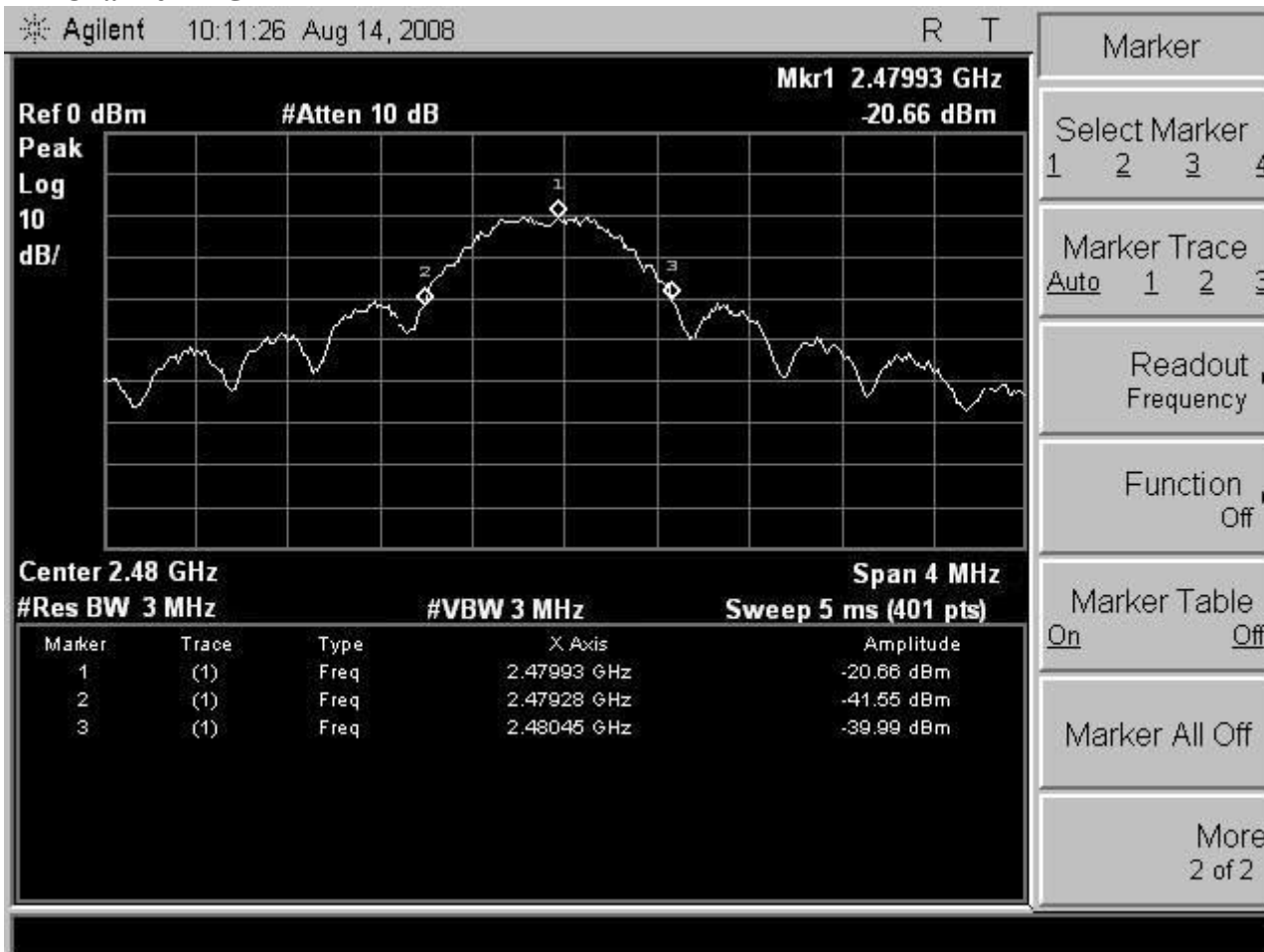

5. TEST OF HOPPING CHANNEL SEPARATION

5.1 Applicable Standard

Section 15.247(a)(1): Frequency hopping systems shall have hopping channel carrier frequencies separated by a minimum of 25 kHz or the 20 dB bandwidth of the hopping channel, whichever is greater.

5.2 EUT Setup

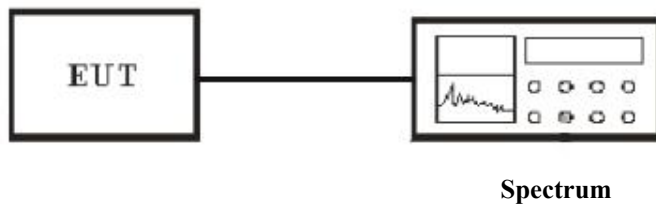

5.3 Test Equipment List and Details

See section 1.4.

5.4 Test Procedure

1. The transmitter output was connected to the spectrum analyzer through an attenuator.
2. Set RBW of spectrum analyzer to 100KHz and VBW to 300KHz.
3. Set Detector to Peak, Trace to Max Hold and Sweep Time is Auto.
4. The Hopping Channel Separation is defined as the separation between 2 neighboring hopping frequencies.
5. Repeat above 1~3 points for the middle and highest channel of the EUT.

5.5 Test Result

Temperature (°C) : 22~23	EUT: BT Headset
Humidity (%RH) : 50~54	M/N: H508
Barometric Pressure (mbar) : 950~1000	Operation Condition: Tx/Rx 8PPSK Mode
Test data: Jul 17, 2008	Test engineer: James

Channel No.	Frequency (MHz)	Channel Separation (kHz)
LOW	2402	1032
MID	2441	1044
HIG	2480	996

Channel Low :



Channel MID :

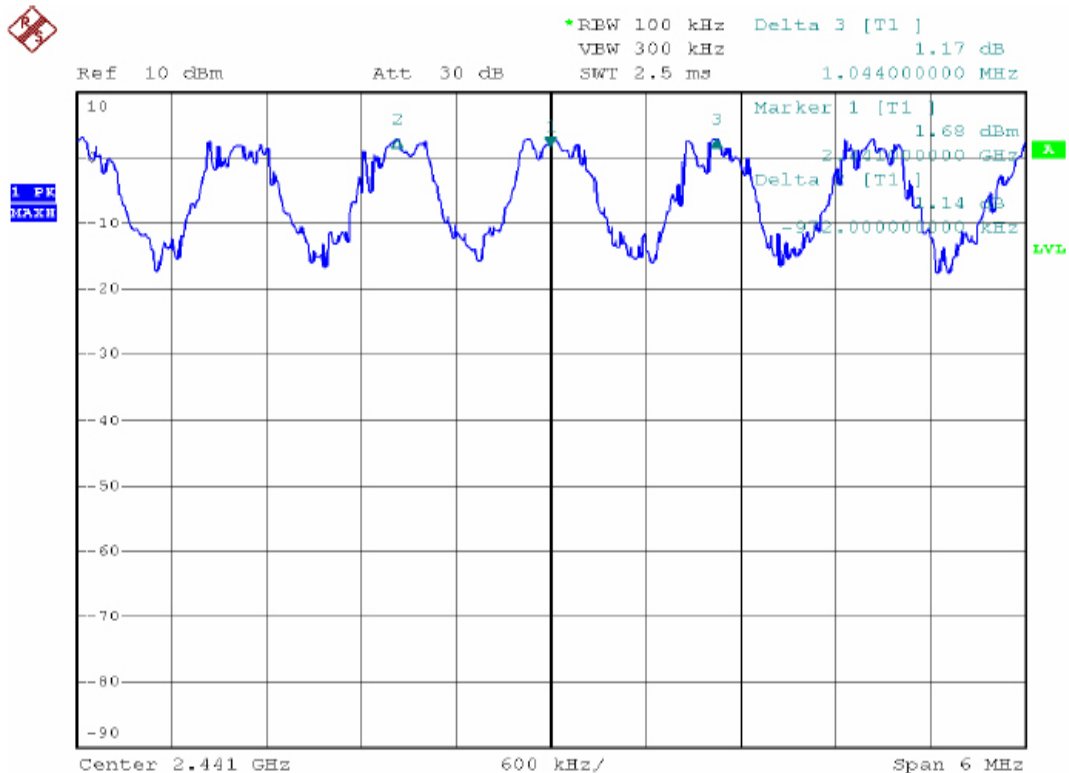

Channel HIG :

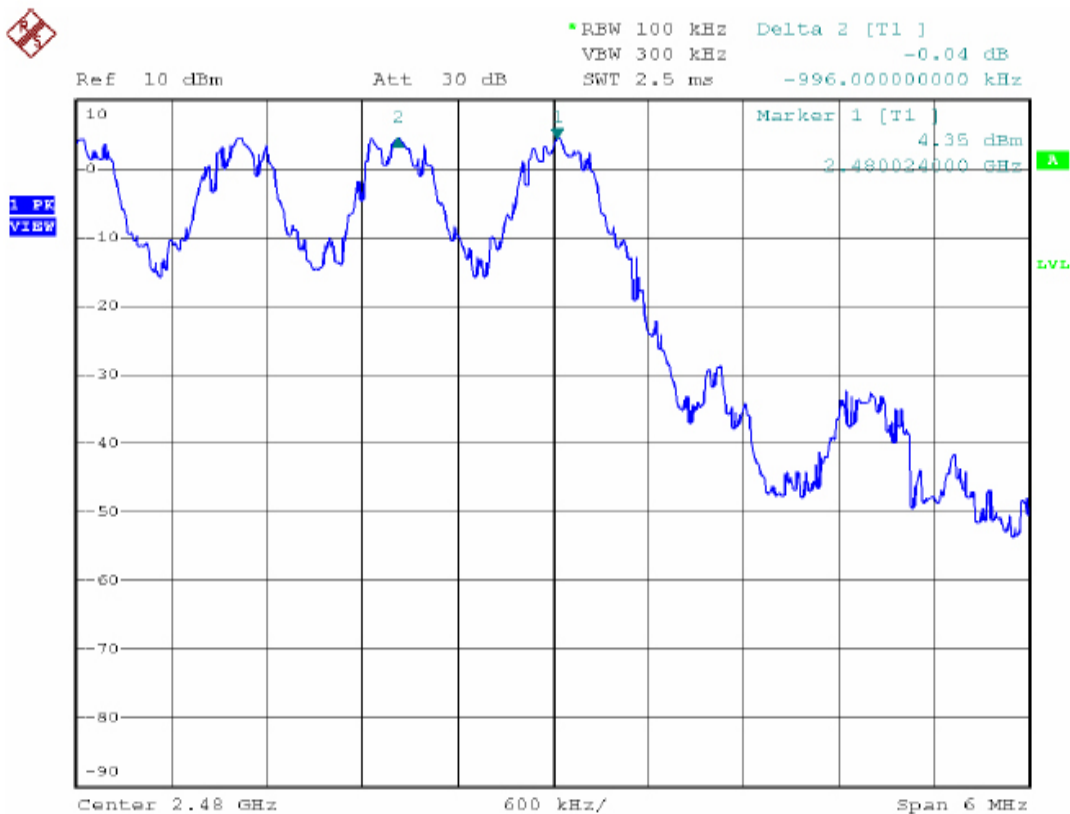

6. TEST OF NUMBER OF HOPPING FREQUENCY

6.1 Applicable Standard

Section 15.247(a)(1)(iii): For frequency hopping systems operating in the 2400-2483.5 MHz band employing at least 15 non-overlapping hopping channels. Frequency hopping system which use fewer than 75 hopping frequencies may employ intelligent hopping techniques to avoid interference to other transmissions. Frequency hopping system may avoid or suppress transmissions on a particular hopping frequency provided that a minimum of 15 non-overlapping channels are used.

6.2 EUT Setup

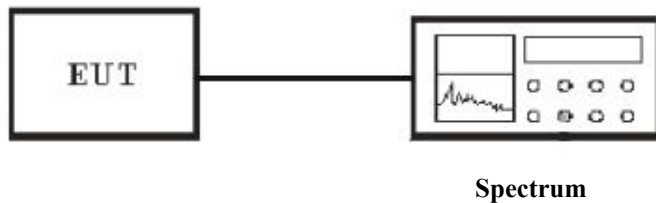

6.3 Test Equipment List and Details

See section 1.4.

6.4 Test Procedure

1. The transmitter output was connected to the spectrum analyzer through an attenuator.
2. Set RBW of spectrum analyzer to 100KHz and VBW to 300KHz.
3. Set Detector to Peak, Trace to Max Hold and Sweep Time is Auto.
4. Observe frequency hopping in 2400MHz~2483.5MHz, there are at least 79 non-overlapping channels.
5. Repeat above 1~3 points for the middle and highest channel of the EUT.

6.5 Test Result

Temperature (°C) : 22~23	EUT: BT Headset
Humidity (%RH) : 50~54	M/N: H508
Barometric Pressure (mbar) : 950~1000	Operation Condition: Tx/Rx 8PPSK Mode
Test data: Jul 18, 2008	Test engineer: James

Frequency (MHz)	Number of Hopping Channel (Channels)	Min. Limit (Channels)
2402~2480	79	>15

7. TEST OF DWELL TIME OF EACH FREQUENCY

7.1 Applicable Standard

Section 15.247(a)(1)(iii): For frequency hopping systems operating in the 2400-2483.5 MHz band
The average time of occupancy on any channel shall not be greater than 0.4 seconds within a period of 0.4seconds multiplied by the number of hopping channels employed.

7.2 EUT Setup

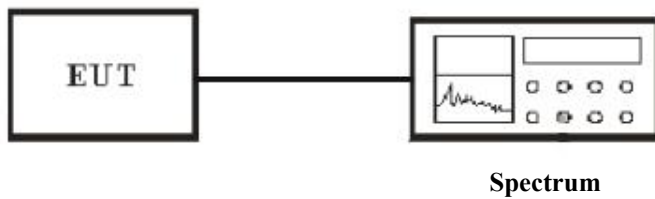

7.3 Test Equipment List and Details

See section 1.4.

7.4 Test Procedure

1. The transmitter output was connected to the spectrum analyzer through an attenuator.
2. Set RBW of spectrum analyzer to 1MHz and VBW to 1MHz.
3. Set Detector to Peak, Trace to Max Hold and Sweep Time is 30ms.
4. Set the center frequency on any frequency would be measure and set the frequency span to zero span.
5. Measure the maximum time duration of one single pulse.

7.5 Test Result

Temperature (°C) : 22~23	EUT: BT Headset
Humidity (%RH) : 50~54	M/N: H508
Barometric Pressure (mbar) : 950~1000	Operation Condition: Tx/Rx Mode
Test data: Jul 18, 2008	Test engineer: James

A period time= 0.4(ms)*79=31.6(s)

CH Low: DH1 time slot=0.453(ms)*(1600/(2*79))*31.6=145.0(ms)
DH3 time slot=1.708(ms)*(1600/(4*79))*31.6=273.3(ms)
DH5 time slot=2.958(ms)*(1600/(6*79))*31.6=315.5(ms)

CH Mid: DH1 time slot=0.453(ms)*(1600/(2*79))*31.6=145.0(ms)
DH3 time slot=1.708(ms)*(1600/(4*79))*31.6=273.3(ms)
DH5 time slot=2.970(ms)*(1600/(6*79))*31.6=316.8(ms)

CH High: DH1 time slot=0.453(ms)*(1600/(2*79))*31.6=145.0(ms)
DH3 time slot=1.717(ms)*(1600/(4*79))*31.6=274.7(ms)
DH5 time slot=2.970(ms)*(1600/(6*79))*31.6=316.8(ms)

**Channel Low
DH1**

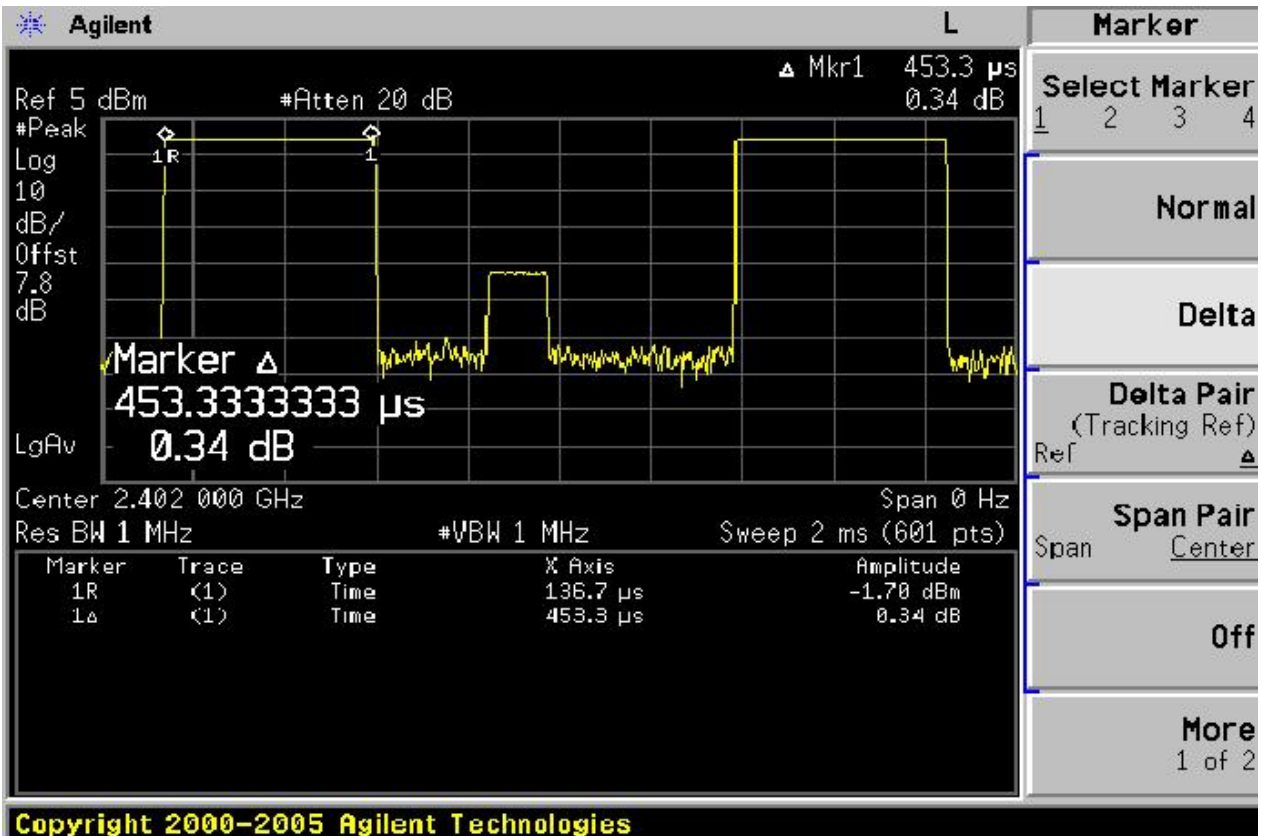

**Channel Low
DH3**

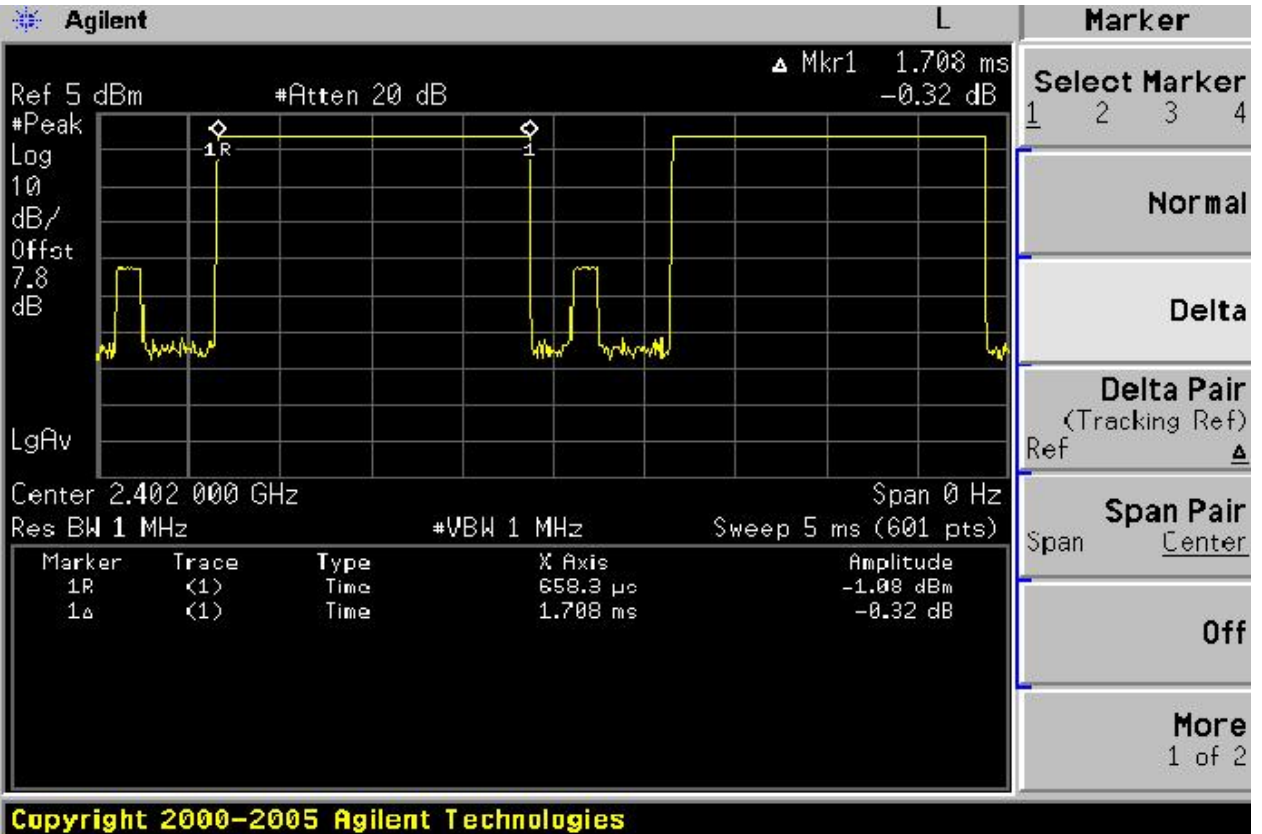

**Channel Low
DH5**

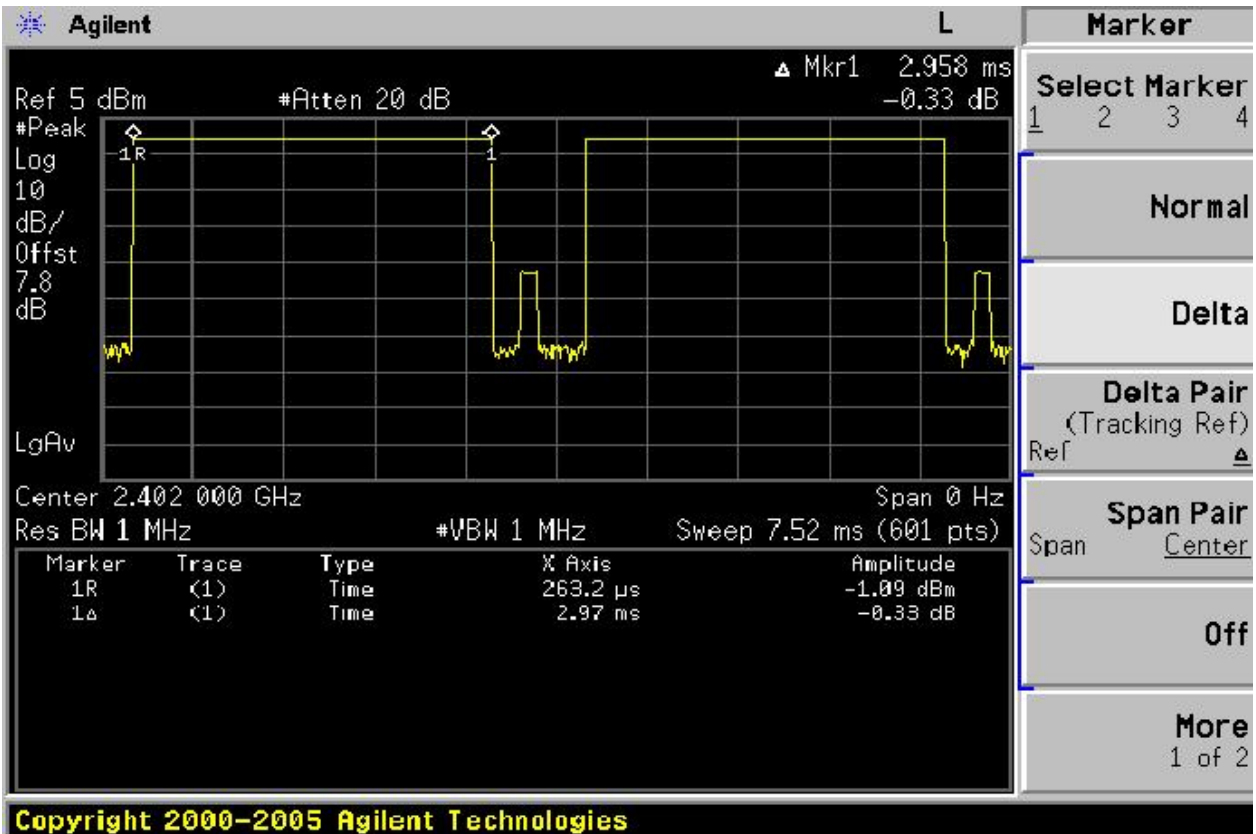

**Channel Mid
DH1**

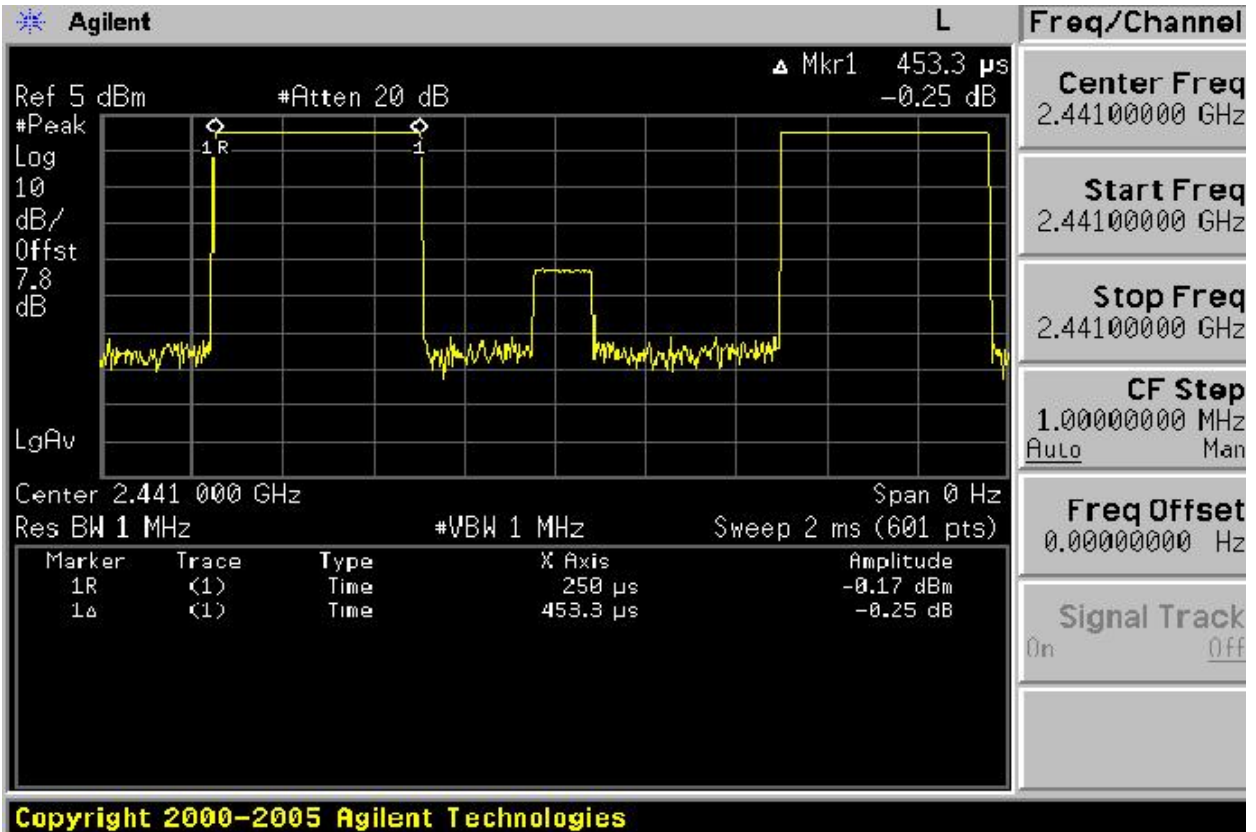

Channel Mid

DH3

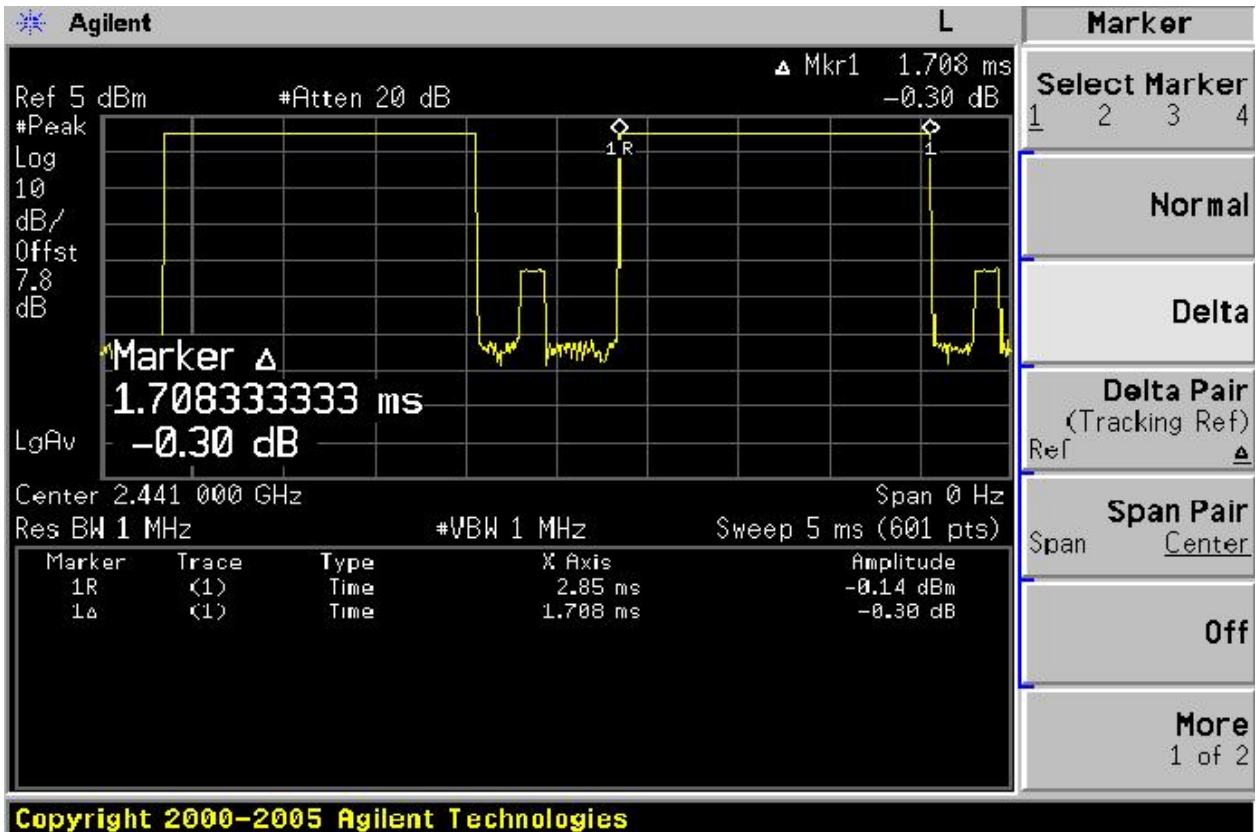

Channel Mid

DH5

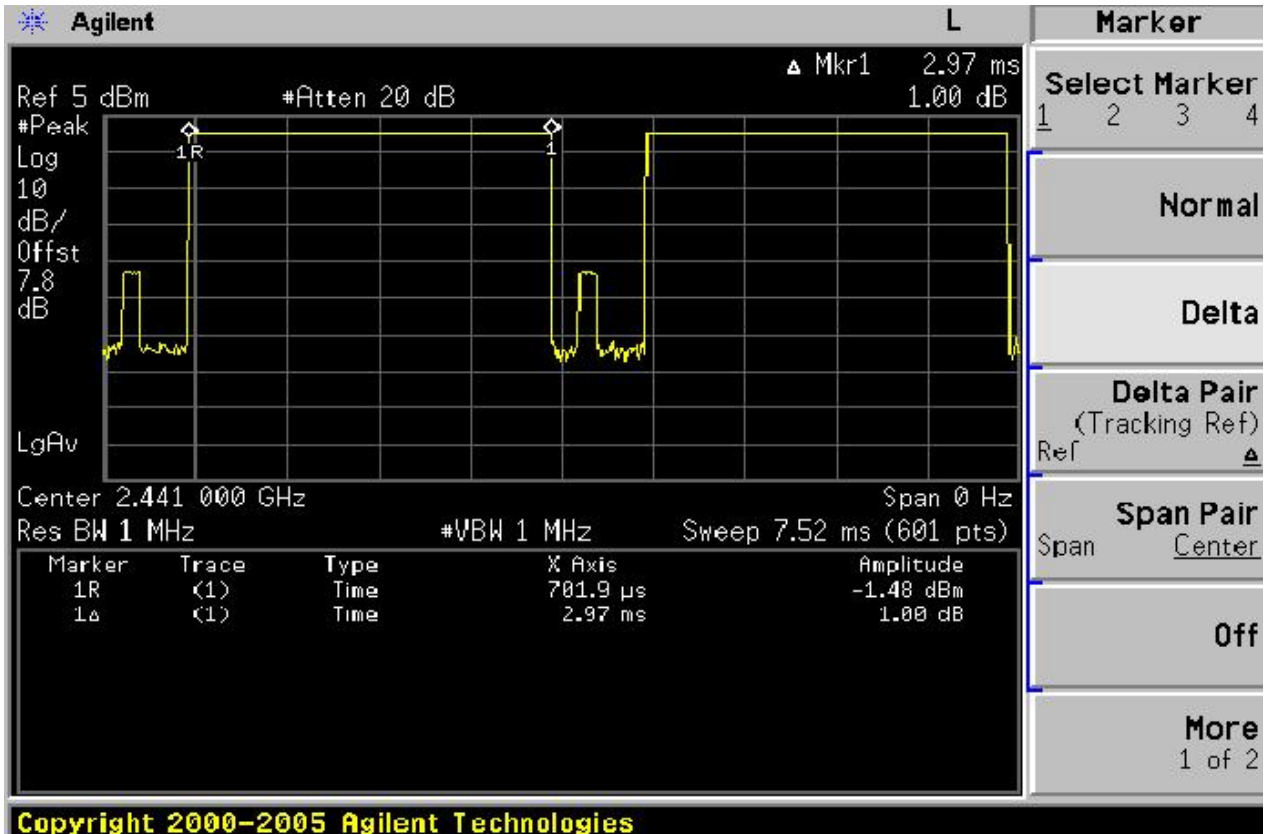

**Channel High
DH1**

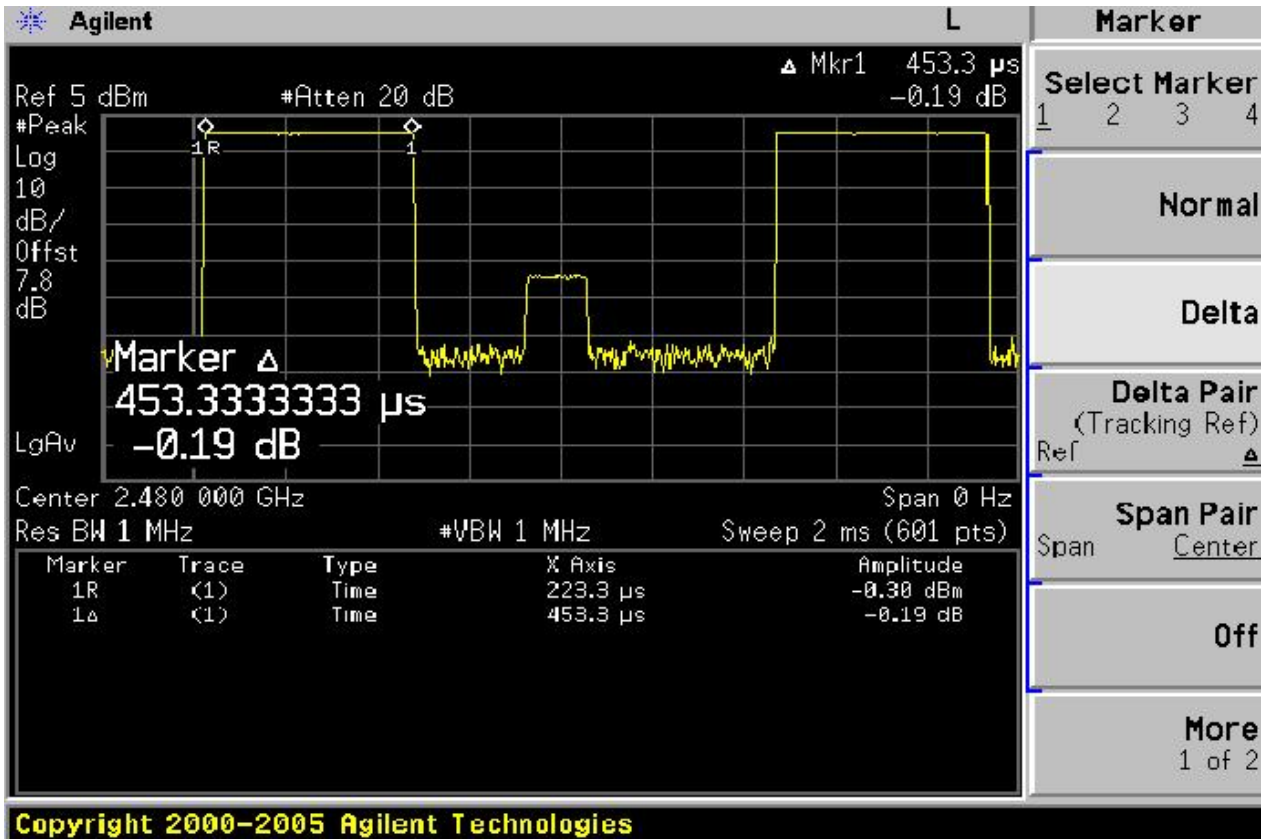

**Channel High
DH3**

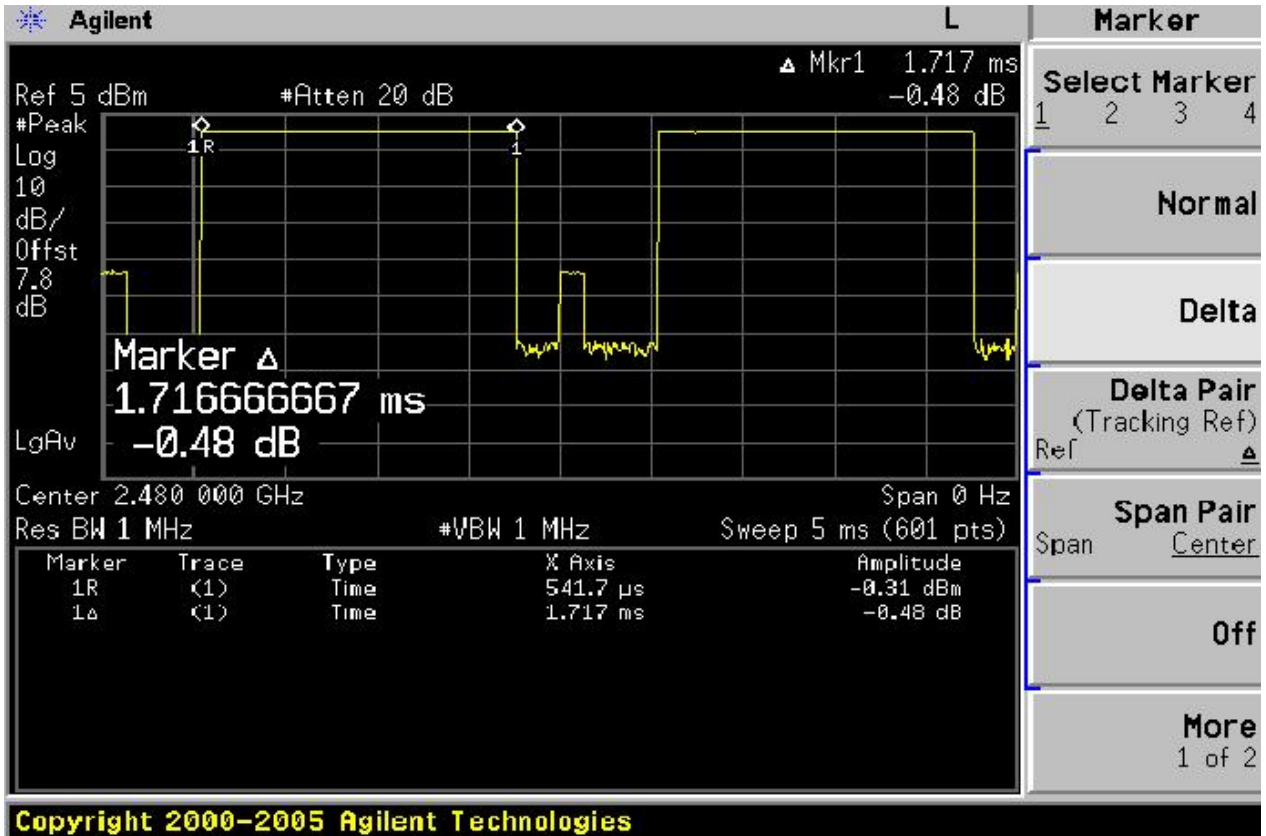

**Channel High
DH5**

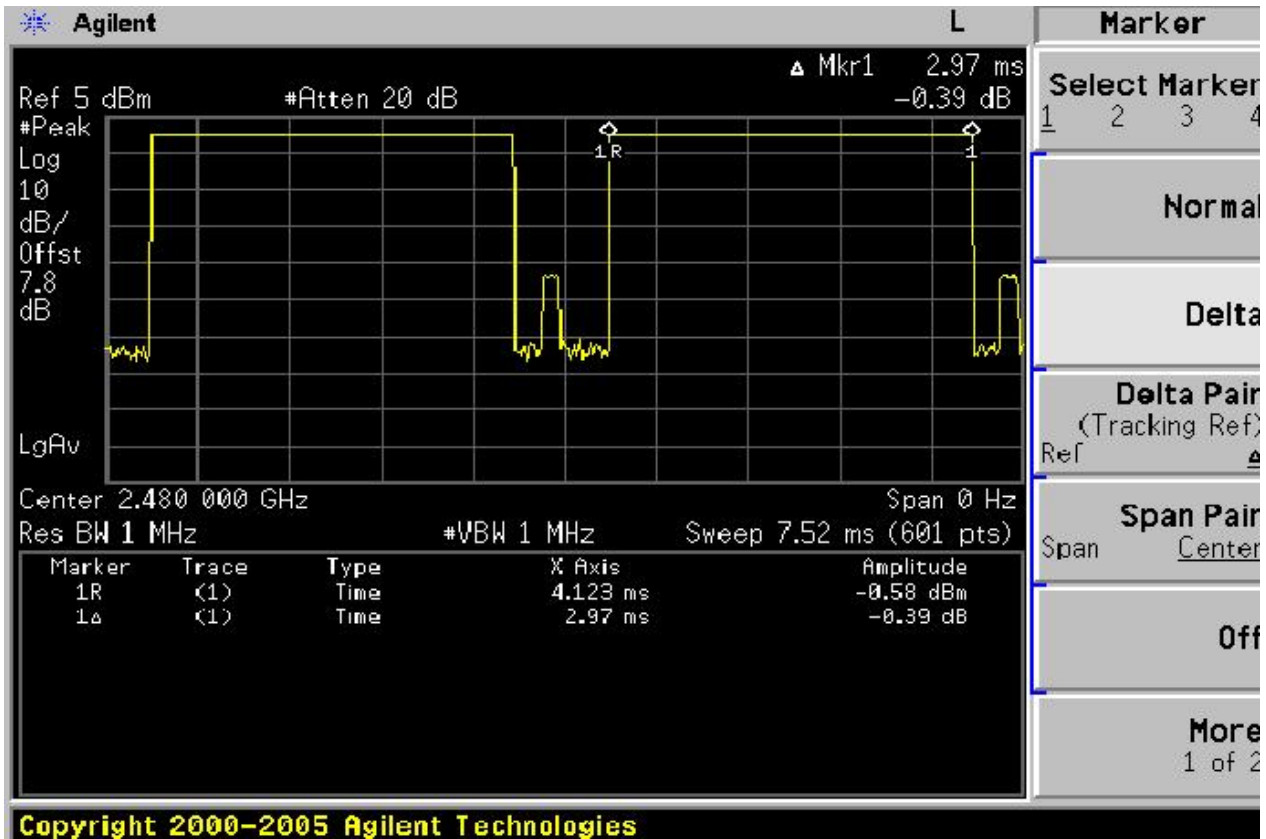

8. TEST OF MAXIMUM PEAK OUTPUT POWER

8.1 Applicable Standard

Section 15.247(b)(1): For frequency hopping systems operating in the 2400-2483.5 MHz band employing at least 75 non-overlapping hopping channels and The maximum peak output power shall not exceed 1 watt. For all other frequency hopping systems in this frequency band, The maximum peak output power shall not exceed 0.125 watt.

8.2 EUT Setup

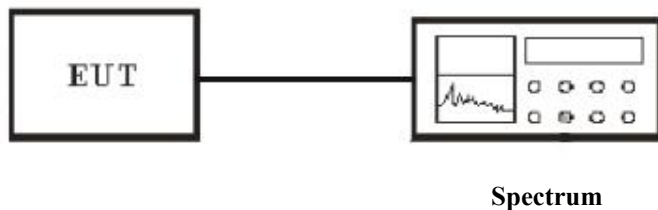

8.3 Test Equipment List and Details

See section 1.4.

8.4 Test Procedure

1. Check the calibration of the measuring instrument using either an internal calibrator or a known signal from an external generator.
2. Position the EUT as shown in figure 4 without connection to measurement instrument. Turn on the EUT and connect its antenna terminal to measurement instrument via a low loss cable. Then set it to any one measured frequency within its operating range and make sure the instrument is operated in its linear range.
3. Use the following spectrum analyzer settings:
 - Span = approximately 5 times the 20 dB bandwidth, centered on a hopping channel
 - RBW > the 20 dB bandwidth of the emission being measured
 - VBW \geq RBW
 - Sweep = auto
 - Detector function = peak
 - Trace = max hold
4. Allow the trace to stabilize. Use the marker-to-peak function to set the marker to the peak of the emission. The indicated level is the peak output power. Plot the result on the screen of spectrum analyzer.
5. Repeat above procedures until all frequencies measured were complete.

8.5 Test Result

For this device (79 hopping channels) the limit is 30 dBm (1 W).

Temperature (°C) : 22~23	EUT: BT Headset
Humidity (%RH): 50~54	M/N: H508
Barometric Pressure (mbar): 950~1000	Operation Condition: Tx/Rx 8PPSK Mode
Test data: Jul 18, 2008	Test engineer: James

Channel No.	Frequency (MHz)	Output Power (dBm)	Limits (dBm)
LOW	2402	3.11	30
MID	2441	3.41	30
HIG	2480	3.61	30

Channel Low

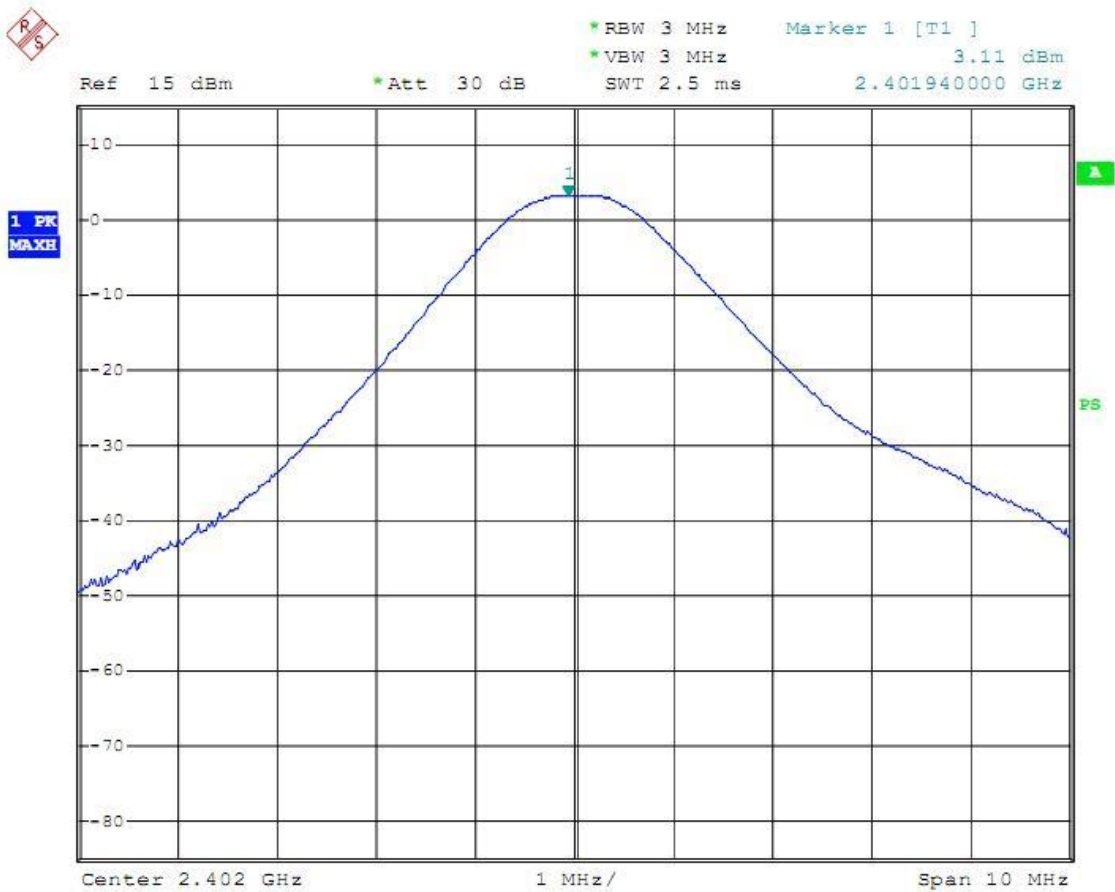

Channel Mid

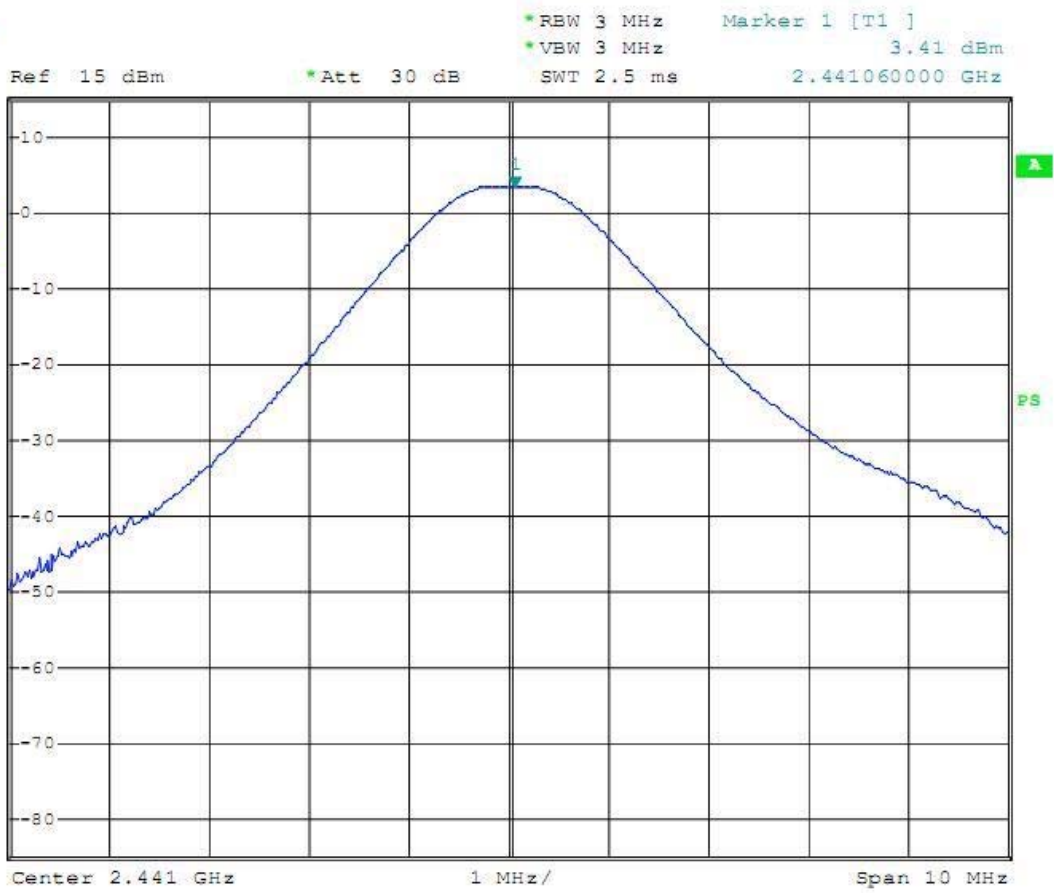

Channel High



RBW 3 MHz Marker 1 [T1]
VEW 3 MHz 3.61 dBm
SWT 2.5 ms 2.480020000 GHz

Ref 15 dBm

Att 30 dB

1 PK
MAXH

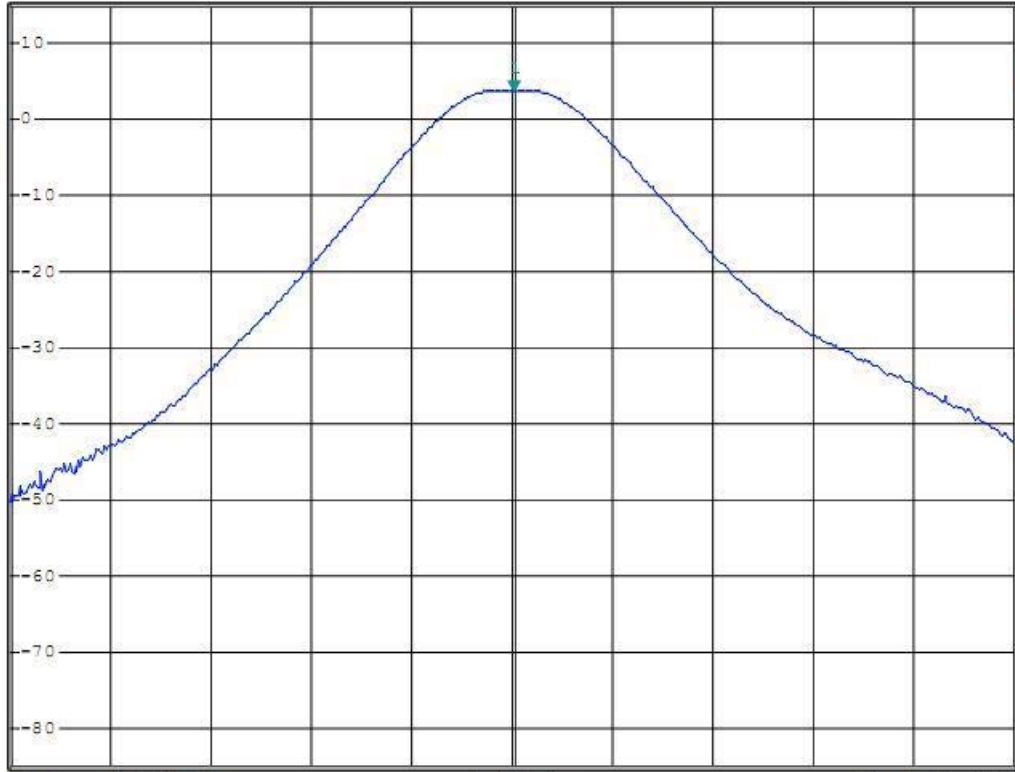

Center 2.48 GHz

1 MHz/

Span 10 MHz

9. TEST OF BAND EDGES EMISSION

9.1 Applicable Standard

Section 15.247(d): In any 100 kHz bandwidth outside the frequency band in which the spread spectrum or digitally modulated intentional radiator is operating, the radio frequency power that is produced by the intentional radiator shall be at least 20 dB below that in the 100 kHz bandwidth within the band that contains the highest level of the desired power, based on either an RF conducted or a radiated measurement. In addition, radiated emissions that fall in the restricted bands, as defined in Section 15.205, must also comply with the radiated emission limits specified in Section 15.209.

9.2 EUT Setup

Radiated Measurement Setup

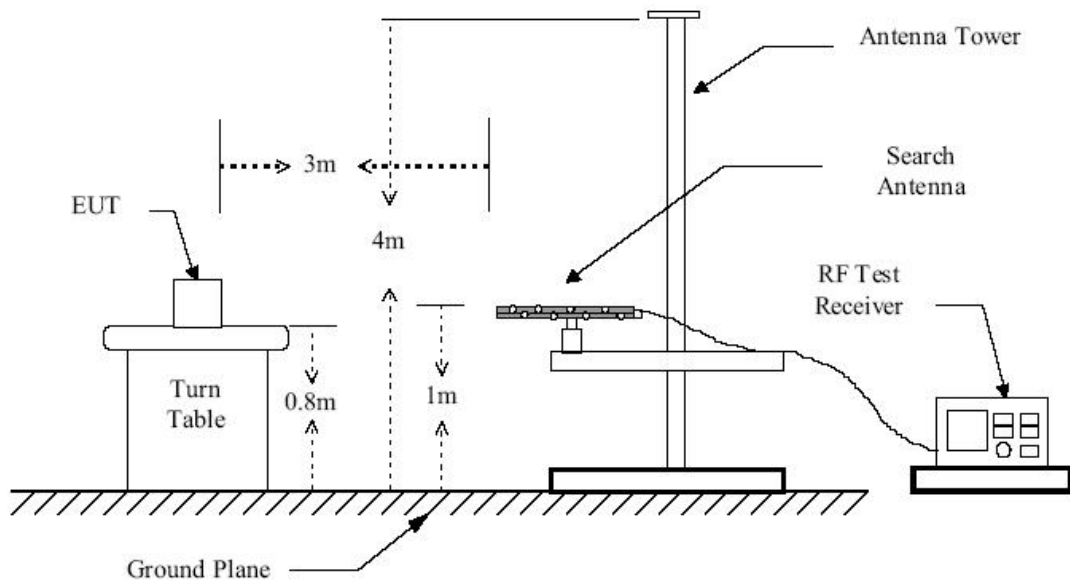

Conducted Measurement Setup

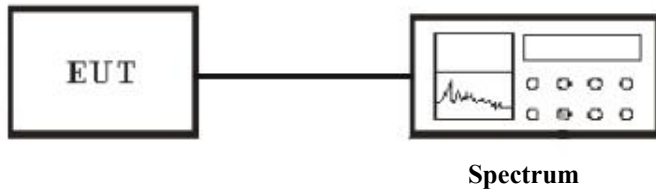

9.3 Test Equipment List and Details

See section 1.4.

9.4 Test Procedure

Conducted Measurement

1. The transmitter is set to the lowest channel.
2. The transmitter output was connected to the spectrum analyzer via a cable and cable loss is used as the offset of the spectrum analyzer.
3. Set both RBW and VBW of spectrum analyzer to 100KHz with convenient frequency span including 100MHz bandwidth from lower band edge. Then detector set to peak and max hold this trace.
4. The lowest band edges emission was measured and recorded.
5. The transmitter set to the highest channel and repeated 2~4.

Radiated Measurement

1. Configure the EUT according to ANSI C63.4.
2. The turntable was rotated by 360 degrees to determine the position of the highest radiation.
3. The height of the broadband receiving antenna was varied between one meter and four meters above ground to find the maximum emission field strength of both horizontal and vertical polarization.
4. For band edge emission, the antenna tower was scan (from 1 M to 4 M) and then the turn table was rotated (from 0 degree to 360 degrees) to find the maximum reading.
5. For band edge emission, use 10Hz VBW and 1MHz RBW for reading under AV and use 100KHz VBW and 1MHz RBW for reading under PK.

9.5 Test Result

Temperature (°C) : 22~23	EUT: BT Headset
Humidity (%RH) : 50~54	M/N: H508
Barometric Pressure (mbar) : 950~1000	Operation Condition: Tx/Rx 8PPSK Mode
Test data: Jul 18, 2008	Test engineer: James

Radiated Test Result

Frequency (MHz)	Antenna Polarization	Emission Read Value (dBμV/m)	Limits (dBμV/m)
<2400	H	29.3	54
>2483.5	H	23.7	54

Conducted Test Result

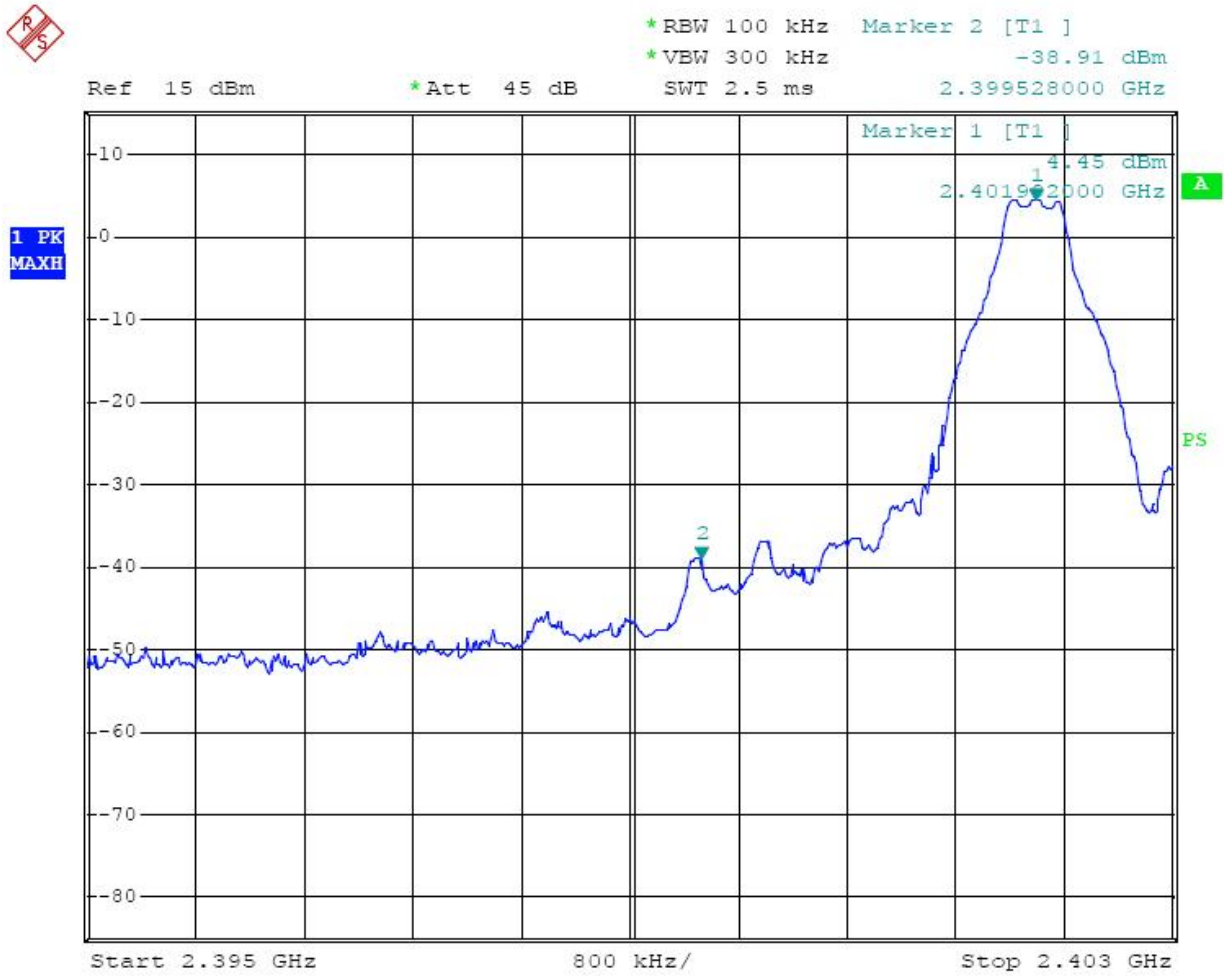



*RBW 100 kHz Marker 2 [T1]
*VBW 300 kHz -48.97 dBm
SWT 2.5 ms 2.484838000 GHz

Ref 15 dBm

*Att 45 dB

1 PK
VIEW

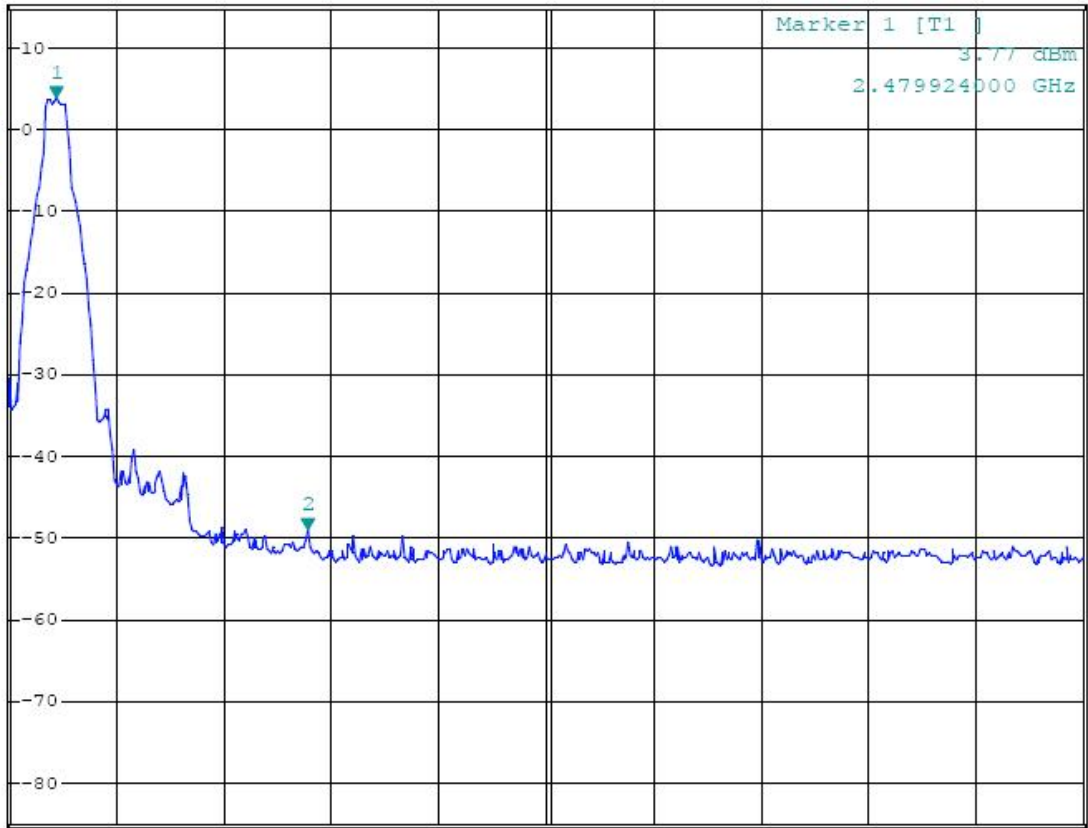

Start 2.479 GHz

2.1 MHz/

Stop 2.5 GHz

10. PEAK POWER SPECTRAL DENSITY MEASUREMENT

10.1 Standard Applicable

According to 15.247(d), for digitally modulated systems, the peak power spectral density conducted from the intentional radiator to the antenna shall not be greater than 8 dBm in any 3 kHz band during any time interval of continuous transmission.

10.2 Test Equipment List and Details

See section 1.4.

10.3 Measurement Procedure

1. Check the calibration of the measuring instrument using either an internal calibrator or a known signal from an external generator.
2. Position the EUT as shown in figure 4 without connection to measurement instrument. Turn on the EUT and connect its antenna terminal to measurement instrument via a low loss cable. Then set EUT to any one measured frequency within its operating range and make sure the instrument is operated in its linear range.
3. Use the following spectrum analyzer settings:
 - Span = 300 kHz, centered on highest level appearing on spectral display
 - RBW = 3 kHz
 - VBW \geq RBW
 - Sweep = 100 s
 - Detector function = peak
 - Trace = max hold
4. Allow the trace to stabilize. Use the marker-to-peak function to set the marker to the peak of the emission. Plot the result on the screen of spectrum analyzer.
5. Repeat above procedures until all measured frequencies were complete.

10.4 Test Result

Temperature (°C) : 22~23	EUT: BT Headset
Humidity (%RH): 50~54	M/N: H508
Barometric Pressure (mbar): 950~1000	Operation Condition: Tx/Rx 8PPSK Mode
Test data: Jul 18, 2008	Test engineer: James

Channel No.	Maximun Power Density
LOW	-1.87dBm
MID	-3.13dBm
HIG	-3.98dBm

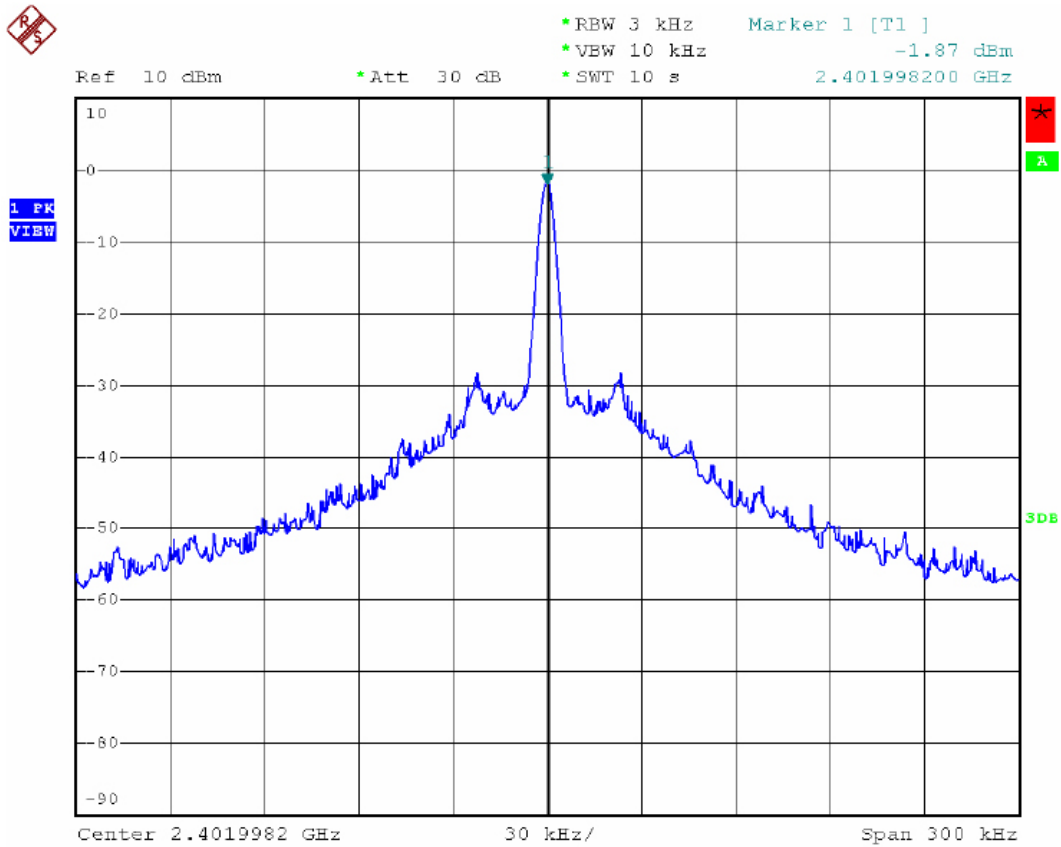

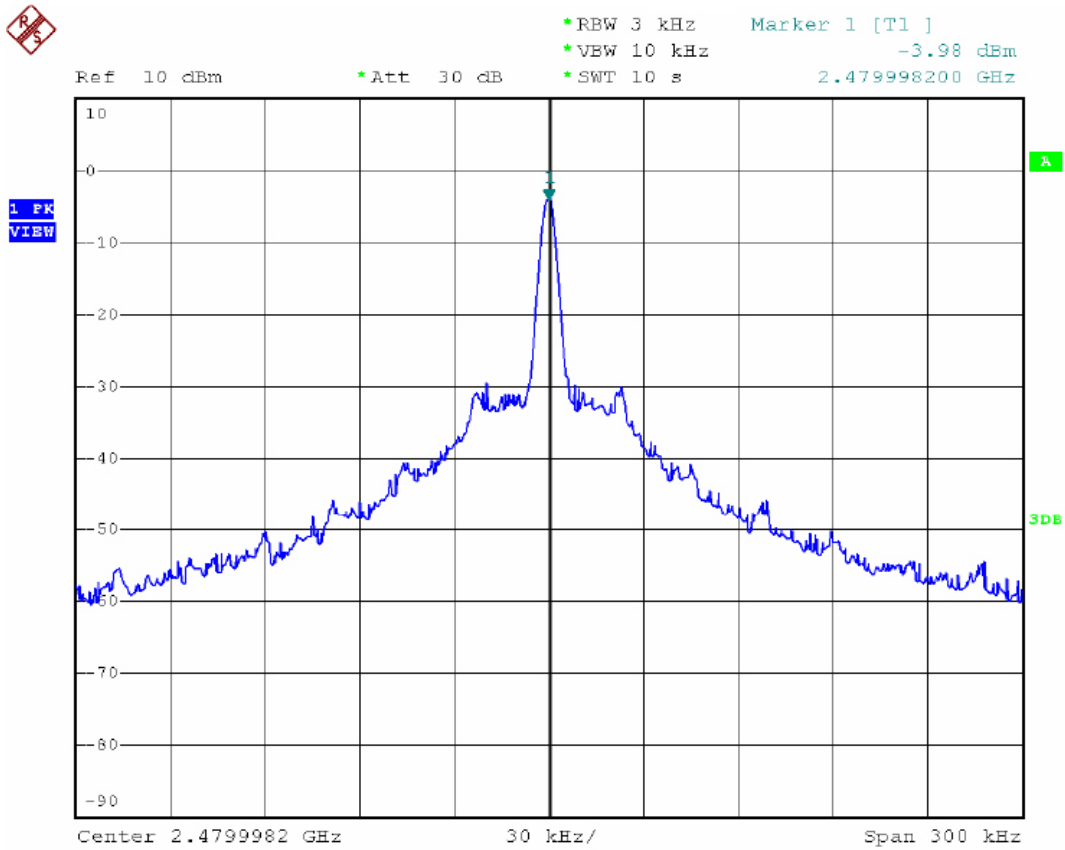
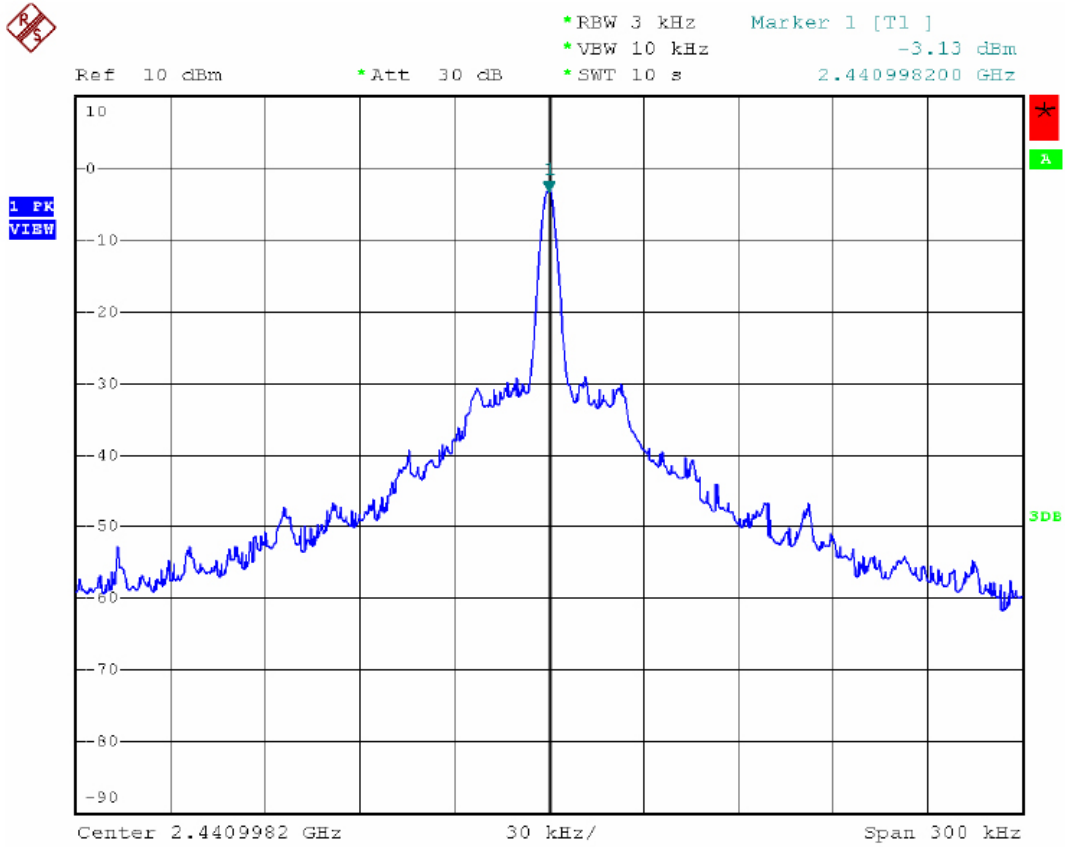

11. TEST OF SPURIOUS RADIATED EMISSION

11.1 Applicable Standard

Section 15.247(d): In any 100 kHz bandwidth outside the frequency band in which the spread spectrum or digitally modulated intentional radiator is operating, the radio frequency power that is produced by the intentional radiator shall be at least 20 dB below that in the 100 kHz bandwidth within the band that contains the highest level of the desired power, based on either an RF conducted or a radiated measurement. In addition, radiated emissions that fall in the restricted bands, as defined in Section 15.205, must also comply with the radiated emission limits specified in Section 15.209.

11.2 EUT Setup

Radiated Measurement Setup

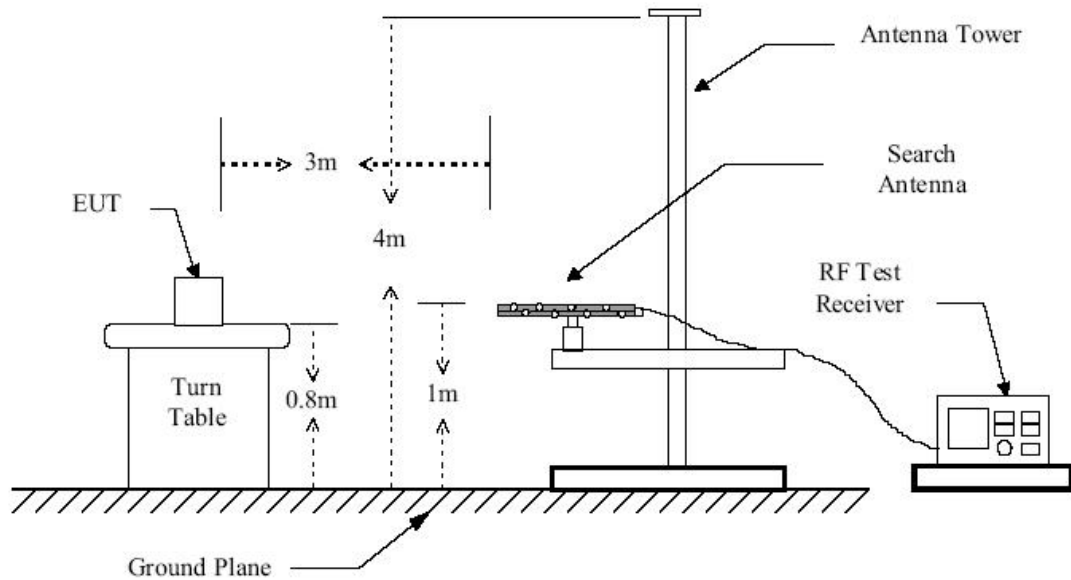

Figure 1 : Frequencies measured below 1 GHz configuration

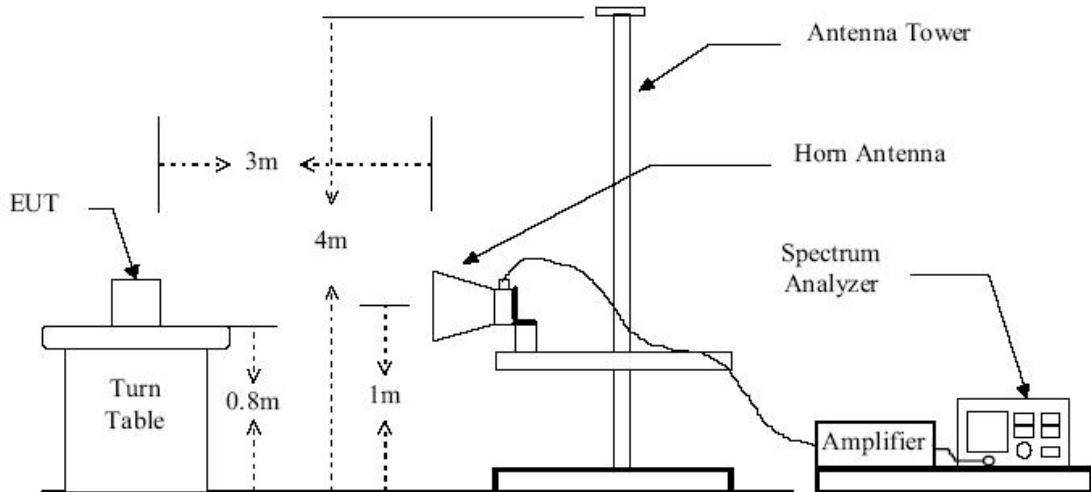
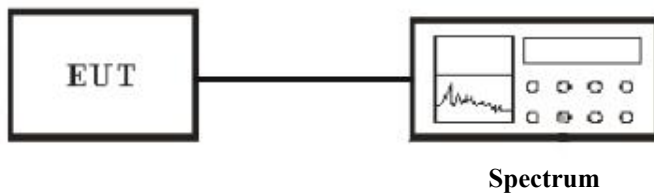

Figure 2 : Frequencies measured above 1 GHz configuration

Conducted Measurement Setup



11.3 Test Equipment List and Details

See section 1.4.

11.4 Test Procedure

Radiated Measurement

1. Configure the EUT according to ANSI C63.4.
2. The EUT was placed on the top of the turntable 0.8 meter above ground.
3. The phase center of the receiving antenna mounted on the top of a height-variable antenna tower was placed 3 meters far away from the turntable.
4. Power on the EUT and all the supporting units.
5. The turntable was rotated by 360 degrees to determine the position of the highest radiation.
6. The height of the broadband receiving antenna was varied between one meter and four meters above ground to find the maximum emission field strength of both horizontal and vertical polarization.
7. For each suspected emission, the antenna tower was scanned (from 1 M to 4 M) and then the turntable was rotated (from 0 degree to 360 degrees) to find the maximum reading.

8. Set the test-receiver system to Peak or CISPR quasi-peak Detect Function with specified bandwidth under Maximum Hold Mode.

Conducted Measurement

1. For emission above 1GHz, conducted measurement method is used.
2. The transmitter is set to the lowest channel.
3. The transmitter output was connected to the spectrum analyzer via a cable and cable loss is used as the offset of the spectrum analyzer.
4. Set RBW to 100KHz and VBW to 1 MHz, Then detector set to peak and max hold this trace.
5. The lowest band edges emission was measured and recorded.
6. The transmitter set to the highest channel and repeated 2~4.

11.5 Test Result

Temperature (°C) : 22~23	EUT: BT Headset
Humidity (%RH) : 50~54	M/N: H508
Barometric Pressure (mbar) : 950~1000	Operation Condition: Tx/Rx 8PPSK Mode
Test data: Jul 21, 2008	Test engineer: James

Spurious Emission (30~1000MHz)

Maximum Frequency (MHz)	Polarity and Level		Limit dBuV/m	Margin dBuv/m
	Polarity	Result dBuV/m		
237.58	V	32.5	46	13.5
334.58	V	38.0	46	8.0
94.99	H	34.8	43.5	8.7

Remark: No further spurious emission found between the lowest internal used/generated frequency and 30 MHz.

Harmonics

Channel HIG				
Maximum Frequency (MHz)	Polarity and Level		Limit dBuV/m	Margin dBuv/m
	Polarity	Result dBuV/m		
4960	H	43.8	54	10.2
4960	V	41.9	54	12.1
7440	H	27.2	54	26.8
7440	V	26.8	54	27.2
9920	H	23.1	54	30.9
9920	V	22.7	54	31.3
12400	--	--	--	--
14880	--	--	--	--
17360	--	--	--	--
19840	--	--	--	--
22320	--	--	--	--
24800	--	--	--	--

Remark: Datas of measurement within this frequency range shown “-” in the table above means the reading of emissions are attenuated more than 20dB below the permissible limits or the field strength is too small to be measured.

Channel MID				
Maximum Frequency (MHz)	Polarity and Level		Limit dBuV/m	Margin dBuv/m
	Polarity	Result dBuV/m		
4882	H	43.3	54	10.7
4882	V	43	54	11
7323	H	26.5	54	27.5
7323	V	26.3	54	27.7
9764	H	19.2	54	34.8
9764	V	19.0	54	35.0
12205	--	--	--	--
14646	--	--	--	--
17087	--	--	--	--
19528	--	--	--	--
21969	--	--	--	--
24410	--	--	--	--

Remark: Datas of measurement within this frequency range shown “-” in the table above means the reading of emissions are attenuated more than 20dB below the permissible limits or the field strength is too small to be measured.

Channel Low				
Maximum Frequency (MHz)	Polarity and Level		Limit dBuV/m	Margin dBuv/m
	Polarity	Result dBuV/m		
4804	V	42	54	12.0
4804	H	41.5	54	12.5
7203	H	26.0	54	28
7203	V	25.2	54	28.8
9608	H	23.2	54	30.8
9608	V	22.3	54	31.7
12010	--	--	--	--
14412	--	--	--	--
16814	--	--	--	--
19216	--	--	--	--
21618	--	--	--	--
24020	--	--	--	--

Remark: Datas of measurement within this frequency range shown “-” in the table above means the reading of emissions are attenuated more than 20dB below the permissible limits or the field strength is too small to be measured.

CONDUCTED TEST RESULTS

Channel Low :

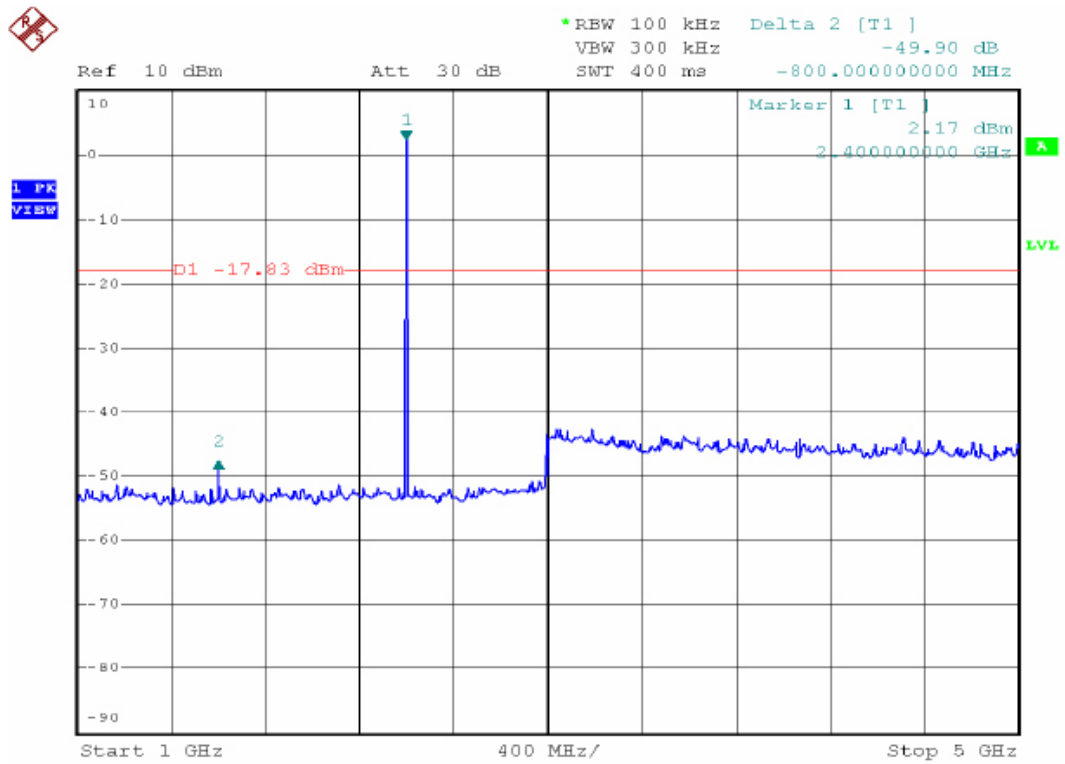
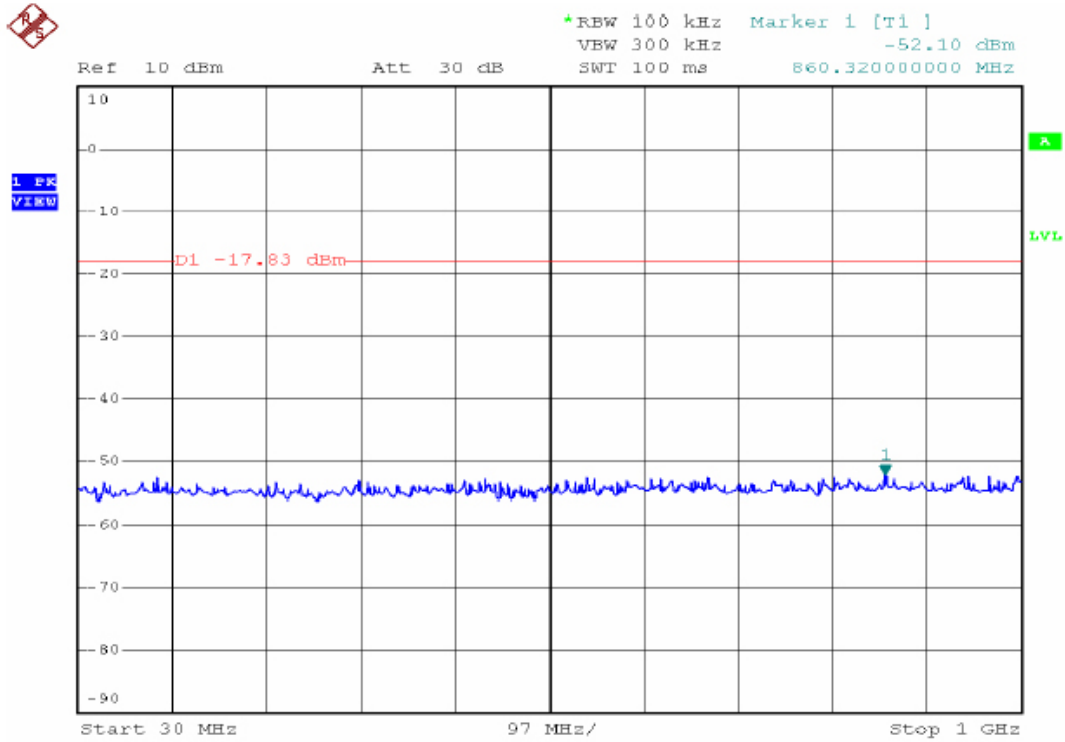

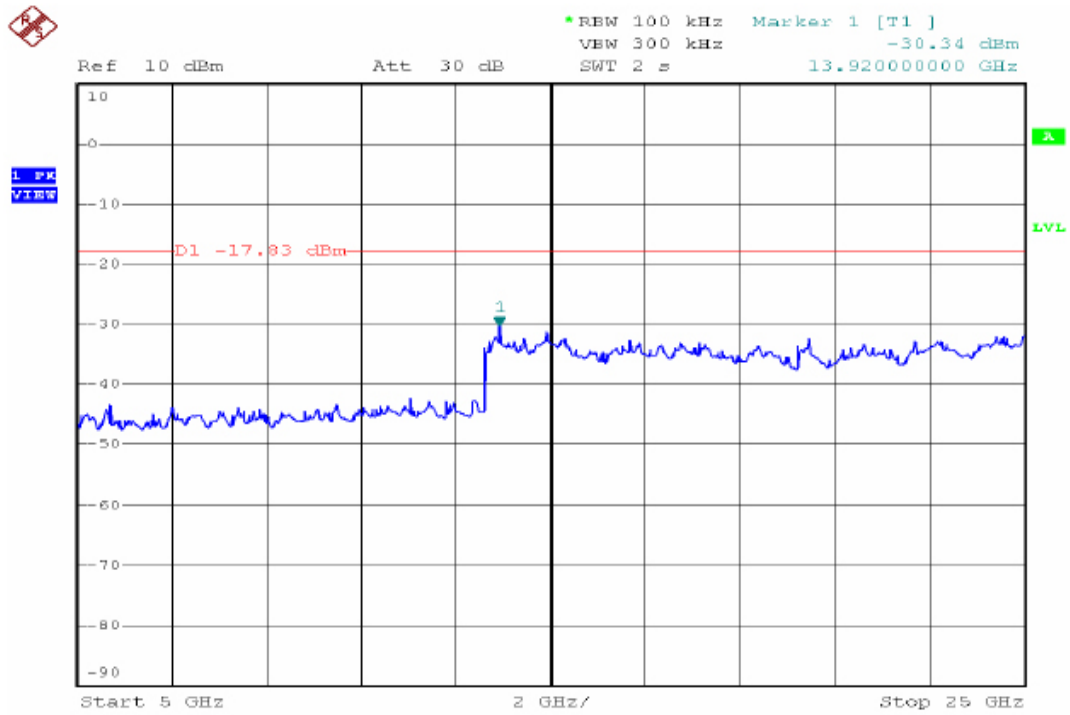

Channel MID :

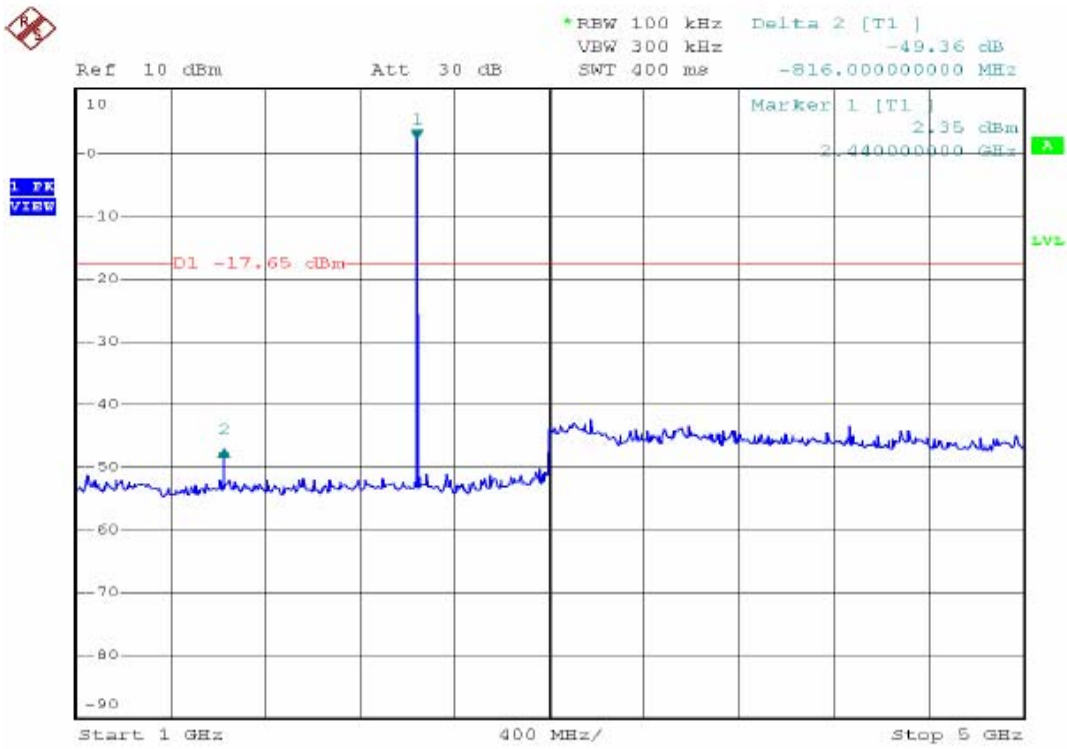
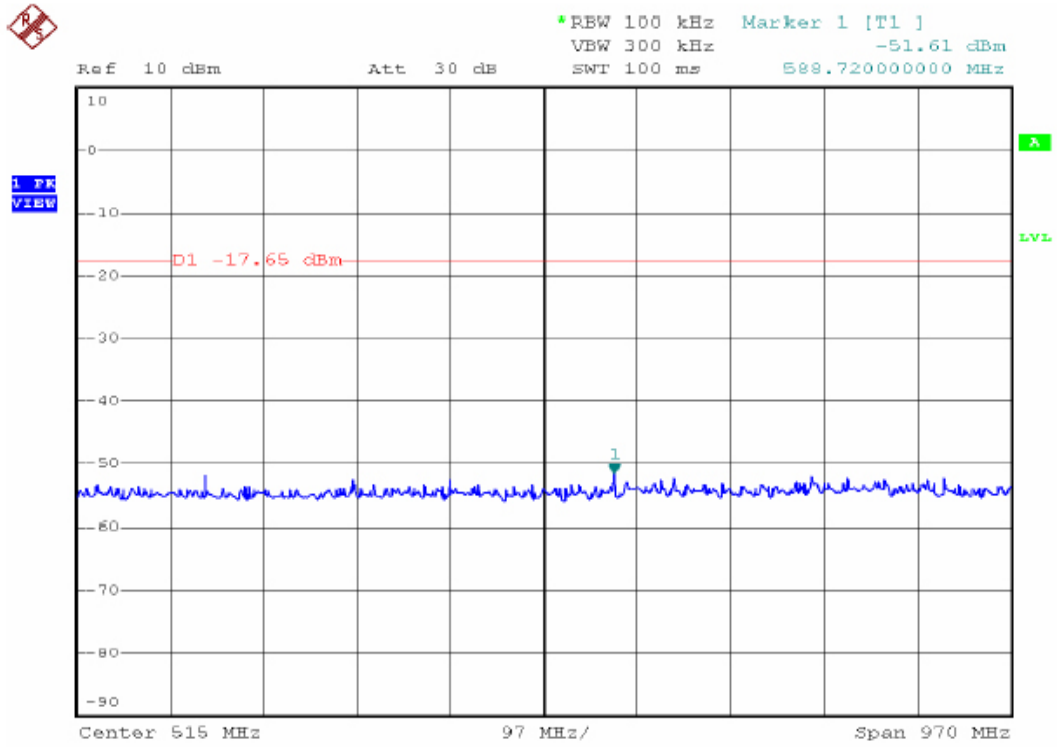

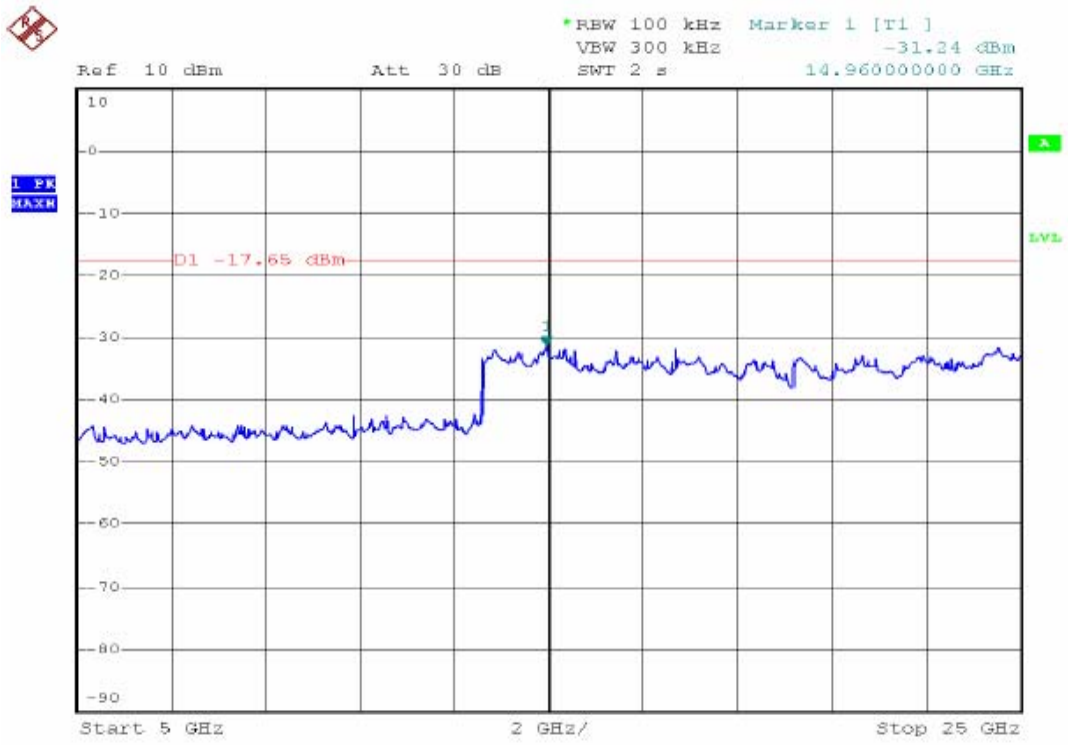

Channel HIG :

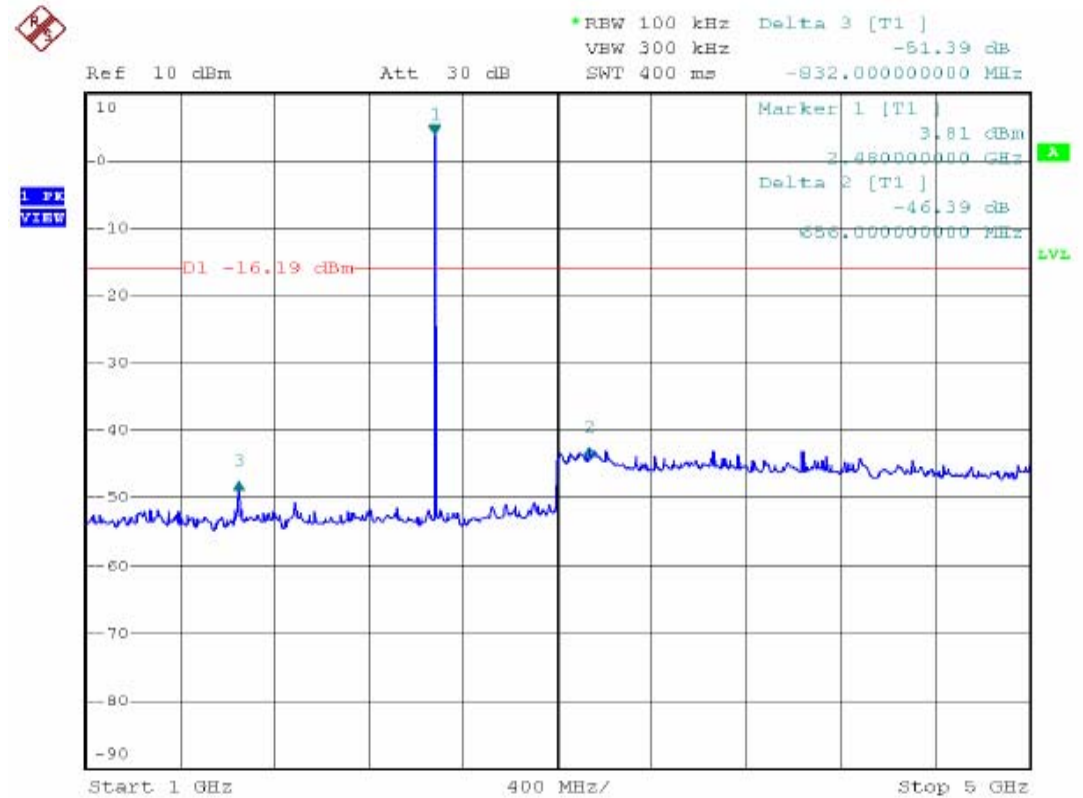
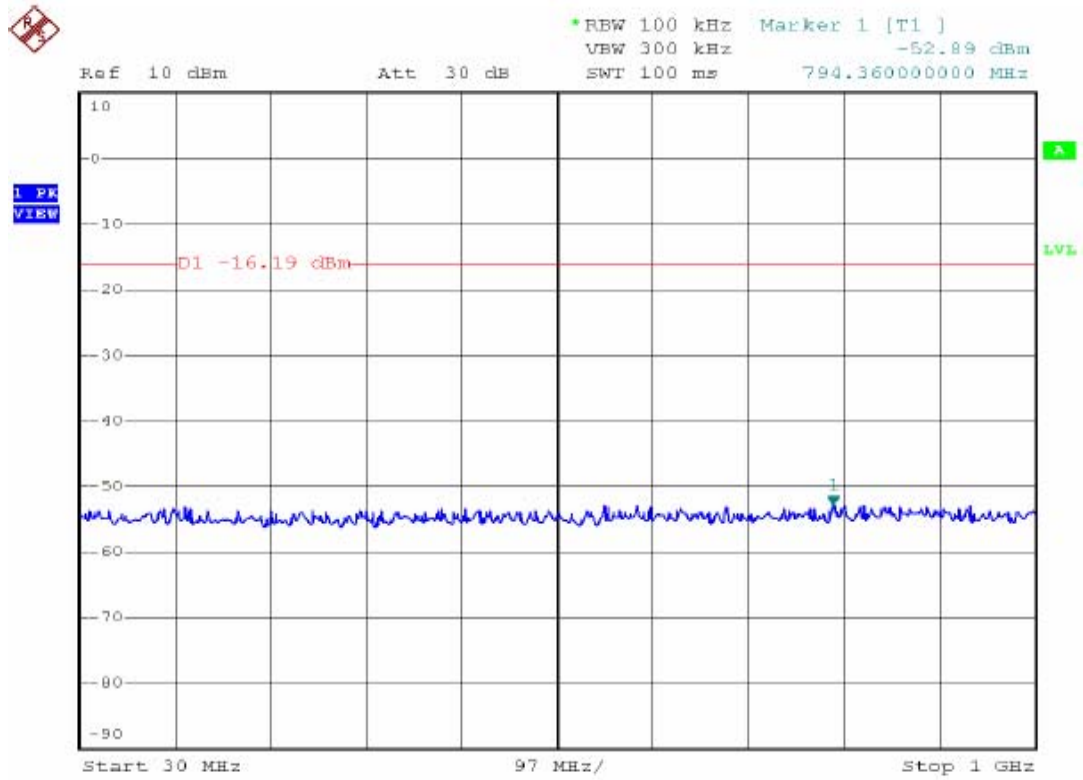

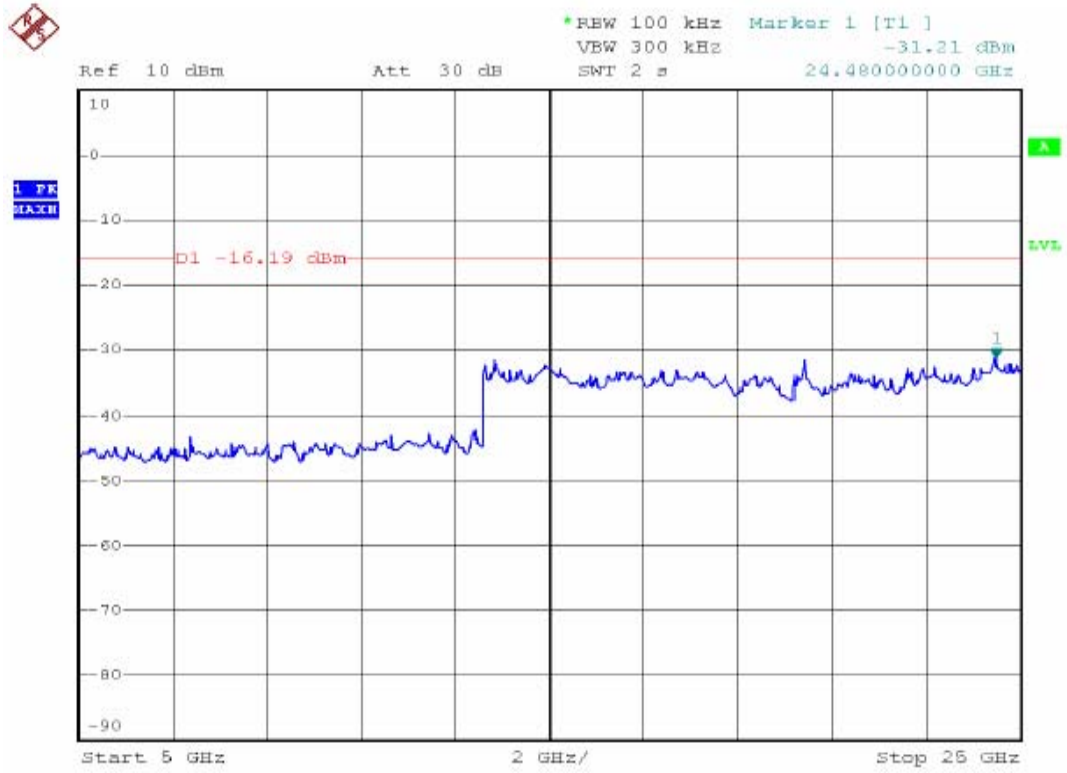

12.FCC ID LABEL

This device complies with Part 15 of the FCC Rules. Operation is subject to the following two conditions:(1)this device may not cause harmful interference, and (2) this device must accept any interference received, including interference that may cause undesired operation.

The above of FCC statement only put into the user manual, haven't onto the device.

The Label must not be a stick-on paper. The Label on these products must be permanently affixed to the product and readily visible at the time of purchase and must last the expected lifetime of the equipment not be readily detachable.

Mark Location:

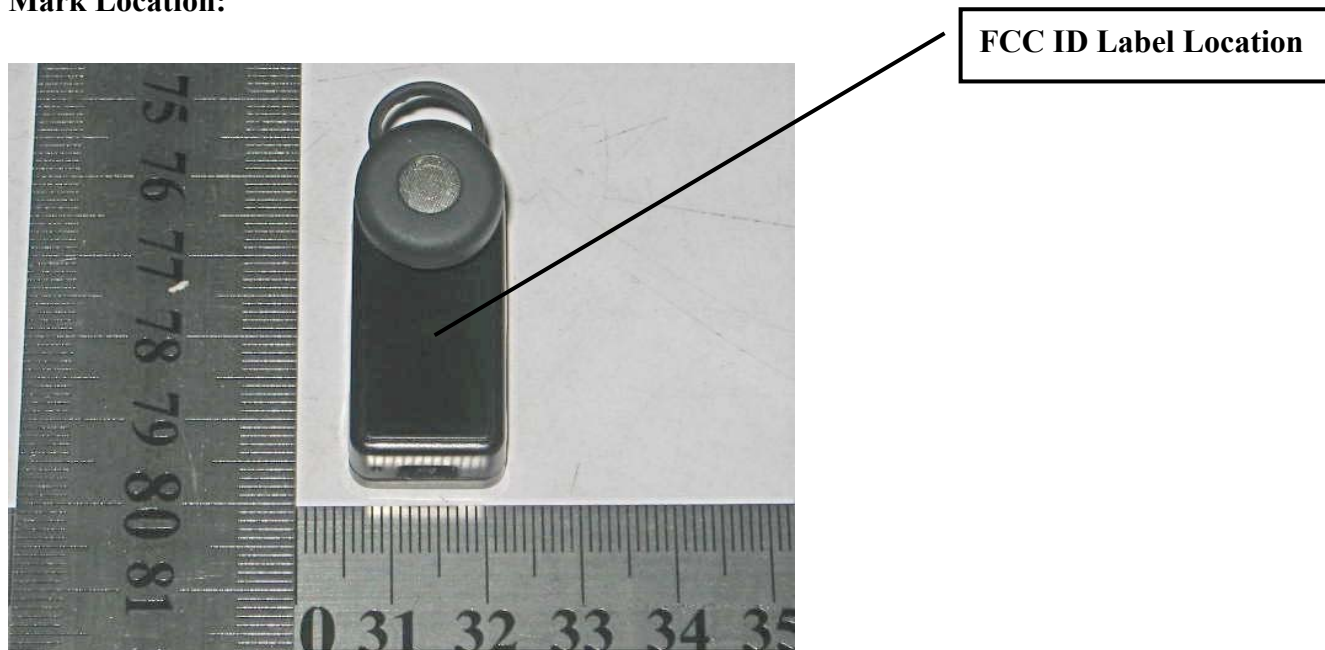

13. PHOTOGRAPH

13.1 Photo of Radiated Measurement



APPENDIX I

(Compliance Statements)

Subclause 15.247 (a) – Equal Hopping Frequency Use

Requirement: Each of the transmitter's hopping channels is used equally on average.

The EUT complies with the Bluetooth RF specifications. For details refer to the Bluetooth standard.

Subclause 15.247 (a) – Receiver Input Bandwidth

Requirement: The associated receiver(s) complies with the requirement that its input bandwidth matches the bandwidth of the transmitted signal.

The receiver bandwidth is equal to the receiver bandwidth in the 79 hopping channel mode, which is 1 MHz. The receiver bandwidth was verified during Bluetooth RF conformance testing.

Subclause 15.247 (a) – Receiver Hopping Capability

Requirement: The associated receiver has the ability to shift frequencies in synchronisation with the transmitted signals.

The EUT complies with the Bluetooth RF specifications. For details refer to the Bluetooth standard.

Subclause 15.247 (a) – Hopping Sequence

Requirement: The hopping sequence is generated and provided with an example.

The channel is represented by a pseudo-random hopping sequence hopping through the 79 RF channels. The hopping sequence is unique for the piconet and is determined by the Bluetooth device address of the master. The X input determines the phase in the 32-hop segment, whereas Y1 and Y2 selects between master-to-slave and slave-to-master transmission. The inputs A to D determine the ordering within the segment, the inputs E and F determine the mapping onto the hop frequencies.

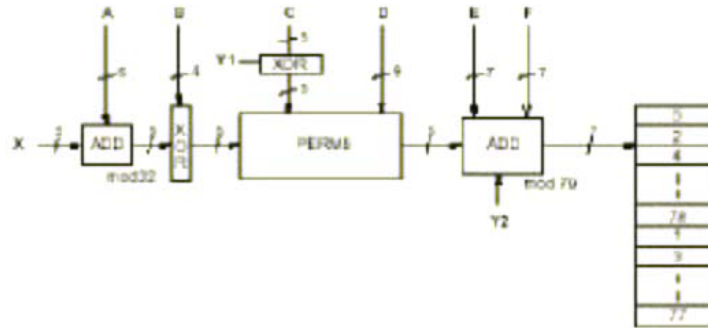

Example data:

Hop sequence {k} for CONNECTION STATE:
 CLK start: 0x0000010
 ULAP: 0x00000000

#ticks: 00 02 | 04 06 | 08 0a | 0c 0e | 10 12 | 14 16 | 18 1a | 1c 1e |

0x0000010:	08 66	10 70	12 19	14 23	16 01	18 05	20 33	22 37
0x0000030:	24 03	26 07	28 35	30 39	32 72	34 76	36 25	38 29
0x0000050:	40 74	42 78	44 27	46 31	48 09	50 13	52 41	54 45
0x0000070:	56 11	58 15	60 43	62 47	32 17	36 19	34 49	38 51
0x0000090:	40 21	44 23	42 53	46 55	48 33	52 35	50 65	54 67
0x00000b0:	56 37	60 39	58 69	62 71	64 25	68 27	66 57	70 59
0x00000d0:	72 29	76 31	74 61	78 63	01 41	05 43	03 73	07 75
0x00000f0:	09 45	13 47	11 77	15 00	64 49	66 53	68 02	70 06
0x0000110:	01 51	03 55	05 04	07 08	72 57	74 61	76 10	78 14
0x0000130:	09 59	11 63	13 12	15 16	17 65	19 69	21 18	23 22
0x0000150:	33 67	35 71	37 20	39 24	25 73	27 77	29 26	31 30
0x0000170:	41 75	43 00	45 28	47 32	17 02	21 04	19 34	23 36
0x0000190:	33 06	37 08	35 38	39 40	25 10	29 12	27 42	31 44
0x00001b0:	41 14	45 16	43 46	47 48	49 18	53 20	51 50	55 52
0x00001d0:	65 22	69 24	67 54	71 56	57 26	61 28	59 58	63 60
0x00001f0:	73 30	77 32	75 62	00 64	49 34	51 42	57 66	59 74
0x0000210:	53 36	55 44	61 68	63 76	65 50	67 58	73 03	75 11
0x0000230:	69 52	71 60	77 05	00 13	02 38	04 46	10 70	12 78
0x0000250:	06 40	08 48	14 72	16 01	18 54	20 62	26 07	28 15
0x0000270:	22 56	24 64	30 09	32 17	02 66	06 74	10 19	14 27
0x0000290:	04 70	08 78	12 23	16 31	18 03	22 11	26 35	30 43
0x00002b0:	20 07	24 15	28 39	32 47	34 68	38 76	42 21	46 29
0x00002d0:	36 72	40 01	44 25	48 33	50 05	54 13	58 37	62 45
0x00002f0:	52 09	56 17	60 41	64 49	34 19	36 35	50 51	52 67
0x0000310:	38 21	40 37	54 53	56 69	42 27	44 43	58 59	60 75
0x0000330:	46 29	48 45	62 61	64 77	66 23	68 39	03 55	05 71
0x0000350:	70 25	72 41	07 57	09 73	74 31	76 47	11 63	13 00
0x0000370:	78 33	01 49	15 65	17 02	66 51	70 67	03 04	07 20
0x0000390:	68 55	72 71	05 08	09 24	74 59	78 75	11 12	15 28
0x00003b0:	76 63	01 00	13 16	17 32	19 53	23 69	35 06	39 22
0x00003d0:	21 57	25 73	37 10	41 26	27 61	31 77	43 14	47 30
0x00003f0:	29 65	33 02	45 18	49 34	19 04	21 08	23 20	25 24

APPENDIX II (Photos of EUT)

Outside View







Interior View

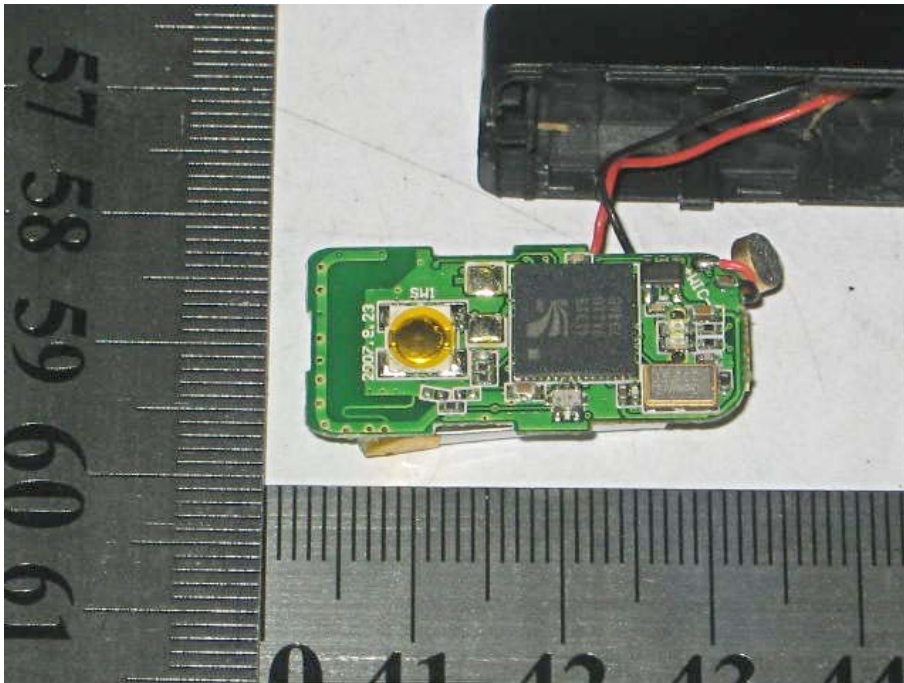

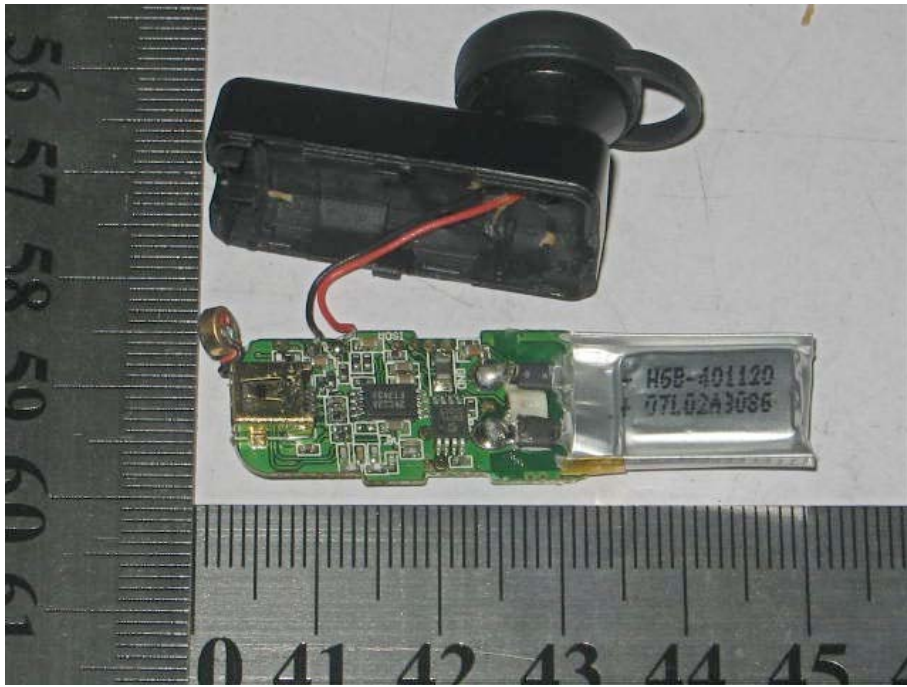

Photos of appurtenance



THE END