



▶ PIT gb with PITreader

PILZ
THE SPIRIT OF SAFETY

Operating Manual-1005249-EN-02
- Control and signal devices



This document is the original document.

Where unavoidable, for reasons of readability, the masculine form has been selected when formulating this document. We do assure you that all persons are regarded without discrimination and on an equal basis.

All rights to this documentation are reserved by Pilz GmbH & Co. KG. Copies may be made for the user's internal purposes. Suggestions and comments for improving this documentation will be gratefully received.

Pilz®, PIT®, PMI®, PNOZ®, Primo®, PSEN®, PSS®, PVIS®, SafetyBUS p®, SafetyEYE®, SafetyNET p®, the spirit of safety® are registered and protected trademarks of Pilz GmbH & Co. KG in some countries.



SD means Secure Digital

1	Introduction	5
1.1	Validity of documentation	5
1.2	Using the documentation	5
1.3	Definition of symbols	5
2	Overview	7
2.1	Product features	7
2.1.1	PIT gb with PITreader Key	7
2.1.2	PIT gb with PITreader Card	7
2.2	Scope of supply	7
2.2.1	PIT gb with PITreader Key	7
2.2.2	PIT gb with PITreader Card	8
3	Safety	9
3.1	Intended use	9
3.2	Safety regulations	9
3.2.1	Additional documents that apply	9
3.2.2	Use of qualified personnel	9
3.2.3	Warranty and liability	10
3.2.4	Disposal	10
3.3	For your safety	10
4	Security	12
5	Function description	13
5.1	Product types	13
5.1.1	PIT gb with PITreader Key	13
5.1.2	PIT gb with PITreader Card	15
5.2	Block diagram	16
5.3	PITreader	16
5.4	Coloured caps	16
6	Installation	17
6.1	Assembly positions	17
6.1.1	Potential installation positions of the mounting bracket on PIT gb with PITreader	17
6.1.2	Potential installation positions of the PIT gb with PITreader	17
6.2	Installing the product	18
6.3	Attach coloured cap to pushbutton	19
6.4	Installation PITreader card holder	20
6.5	Attach PITreader transponder sticker	22
7	Wiring	23
7.1	Terminal assignment connectors	23
8	Commissioning	25
8.1	Connection to evaluation device	25
8.2	Configure PITreader	25
8.3	Checking the product	25

9	Operation	26
9.1	Display and control elements	26
9.2	PITreader	26
9.2.1	Position transponder on the PITreader	26
9.2.2	LED display PITreader	26
9.2.3	Firmware update PITreader	26
9.2.4	Reset PITreader to default setting	26
10	Troubleshooting	27
11	Maintenance and testing	28
12	Dimensions	29
13	Technical details	30
13.1	Safety characteristic data	33
14	Supplementary data	34
14.1	Radio approvals	34
14.1.1	PIT gb with PITreader Key	34
14.1.2	PIT gb with PITreader Card	34
14.2	Network data	35
15	Order reference	36
15.1	Product	36
15.2	Transponder key	36
15.3	Transponder cards	37
15.4	Transponder sticker	38
15.5	Accessories	39
16	EC declaration of conformity	41
17	UKCA-Declaration of Conformity	42

1 Introduction

1.1 Validity of documentation

This documentation is valid for the product PIT gb with PITreader. It is valid until new documentation is published.

This operating manual explains the function and operation, describes the installation and provides guidelines on how to connect the product.

1.2 Using the documentation

This document is intended for instruction. Only install and commission the product if you have read and understood this document. The document should be retained for future reference.

1.3 Definition of symbols

Information that is particularly important is identified as follows:



DANGER!

This warning must be heeded! It warns of a hazardous situation that poses an immediate threat of serious injury and death and indicates preventive measures that can be taken.



WARNING!

This warning must be heeded! It warns of a hazardous situation that could lead to serious injury and death and indicates preventive measures that can be taken.



CAUTION!

This refers to a hazard that can lead to a less serious or minor injury plus material damage, and also provides information on preventive measures that can be taken.



NOTICE

This describes a situation in which the product or devices could be damaged and also provides information on preventive measures that can be taken. It also highlights areas within the text that are of particular importance.





INFORMATION

This gives advice on applications and provides information on special features.



2 Overview

2.1 Product features

2.1.1 PIT gb with PITreader Key

- ▶ Housing with E-Stop pushbutton, 2 illuminated pushbuttons and PITreader Key
- ▶ PIT gb with PITreader Key is available in two versions:
 - PIT gb RLL E y up ETH with connections on the E-STOP end
 - PIT gb RLL E y down ETH with connections on the PITreader end
- ▶ PITreader Key: Authentication is via a transponder key (see [Order reference: Transponder key](#)  36])
- ▶ Connector design: a 12-pin M12 male connector and a 4-pin M12 female connector
- ▶ Slimline design
- ▶ Control elements finally wired and installed
- ▶ Coloured caps for pushbuttons, to mark the function
- ▶ Labelling option for individual marking of the control elements
- ▶ Can be installed in different directions (see [Assembly positions](#)  17])

2.1.2 PIT gb with PITreader Card

- ▶ Housing with E-STOP pushbutton, 2 illuminated pushbuttons and PITreader Card
- ▶ PIT gb with PITreader Card is available in two versions:
 - PIT gb QLLE y up ETH with connections on the E-STOP end
 - PIT gb QLLE y down ETH with connections on the PITreader end
- ▶ PITreader Card: Authentication is via transponder cards, transponder stickers and/or transponder keys (see [Order reference: Transponder key](#)  36])
- ▶ Connector design: a 12-pin M12 male connector and a 4-pin M12 female connector
- ▶ Slimline design
- ▶ Control elements finally wired and installed
- ▶ Coloured caps for pushbuttons, to mark the function
- ▶ Labelling option for individual marking of the control elements
- ▶ Can be installed in different directions (see [Assembly positions](#)  17])

2.2 Scope of supply

2.2.1 PIT gb with PITreader Key

- ▶ PIT gb RLL E y up ETH or PIT gb RLL E y down ETH
- ▶ 2 washers M5
- ▶ Coloured caps (set), assorted colours

2.2.2 PIT gb with PITreader Card

- ▶ PIT gb QLLE y up ETH or PIT gb QLLE y down ETH
- ▶ 2 washers M5
- ▶ Coloured caps (set), assorted colours

3 Safety

3.1 Intended use

The product PIT gb with PITreader is intended for use in safety circuits in accordance with IEC EN 60947-5-5, EN ISO 13850. Before using the product, a safety assessment of the overall system is needed in accordance with the Machinery Directive.

The PIT gb with PITreader is a system for authentication and authorisation on control systems. Authentication is via appropriate transponders.

The PIT gb with PITreader must be used in combination with a suitable evaluation device (see [Connection to evaluation device](#) [ 25]).

The following is deemed improper use in particular:

- ▶ Any component, technical or electrical modification to the product
- ▶ Use of the product outside the areas described in this manual
- ▶ Use of the product outside the technical details (see chapter entitled "[Technical details](#) [ 30]").



NOTICE

EMC-compliant electrical installation

The product is designed for use in an industrial environment. The product may cause interference if installed in other environments. If installed in other environments, measures should be taken to comply with the applicable standards and directives for the respective installation site with regard to interference.

Foreseeable misuse

If using the PIT gb with PITreader under corrosive environmental conditions (cooling emulsions, surface treatment, gases, ...):

- ▶ Please contact Pilz.

3.2 Safety regulations

3.2.1 Additional documents that apply

You should also read and take note of the following document:

- ▶ Operating manual PITreader

You will need to be conversant with the information in this document to fully understand this operating manual.

3.2.2 Use of qualified personnel

The products may only be assembled, installed, programmed, commissioned, operated, de-commissioned and maintained by persons who are competent to do so.

A competent person is a qualified and knowledgeable person who, because of their training, experience and current professional activity, has the specialist knowledge required. In order to inspect, assess and handle products, devices, systems, plant and machinery, this person must be familiar with the state of the art and the applicable national, European and international laws, directives and standards.

It is the company's responsibility only to employ personnel who

- ▶ Are familiar with the basic regulations concerning health and safety / accident prevention,
- ▶ Have read and understood the information provided in the section entitled Safety
- ▶ Have a good knowledge of the generic and specialist standards applicable to the specific application.

3.2.3 Warranty and liability

All claims to warranty and liability will be rendered invalid if

- ▶ The product was used contrary to the purpose for which it is intended,
- ▶ Damage can be attributed to not having followed the guidelines in the manual,
- ▶ Operating personnel are not suitably qualified,
- ▶ Any type of modification has been made (e.g. exchanging components on the PCB boards, soldering work etc.)
- ▶ The product was opened.

3.2.4 Disposal

- ▶ When decommissioning, please comply with local regulations regarding the disposal of electronic devices, such as the Electrical and Electronic Equipment Act.

3.3 For your safety



WARNING!

Risk of injury due to loss of the safety function.

Manipulation of the E-STOP pushbutton control element S4 may lead to serious injury and death.

- You should prevent the control element being manipulated with a spare control element.
- Only Pilz may exchange control elements.
- Before disposing of a defective PIT gb with PITreader: the PIT gb with PITreader must be safety decommissioned. To do this, all the data must be deleted from the product, see under "[Reset PITreader to default setting \[📖 26\]](#)".



INFORMATION

Do not remove the two protective caps on the connector until you are just about to connect the product.

4 Security

To secure plants, systems, machines and networks against cyberthreats it is necessary to implement (and continuously maintain) an overall industrial security concept that is state of the art.

Perform a risk assessment in accordance with VDI/VDE 2182 or IEC 62443-3-2 and plan the security measures with care. If necessary, seek advice from Pilz Customer Support.

Further information on Security can be found in the operating manual for the PITreader (1004806).

5 Function description

5.1 Product types

In order to control the functions of a whole plant or machine, the PIT gb with PITreader contains the following:

- ▶ One E-STOP pushbutton
- ▶ Two pushbuttons
- ▶ One PITreader

5.1.1 PIT gb with PITreader Key

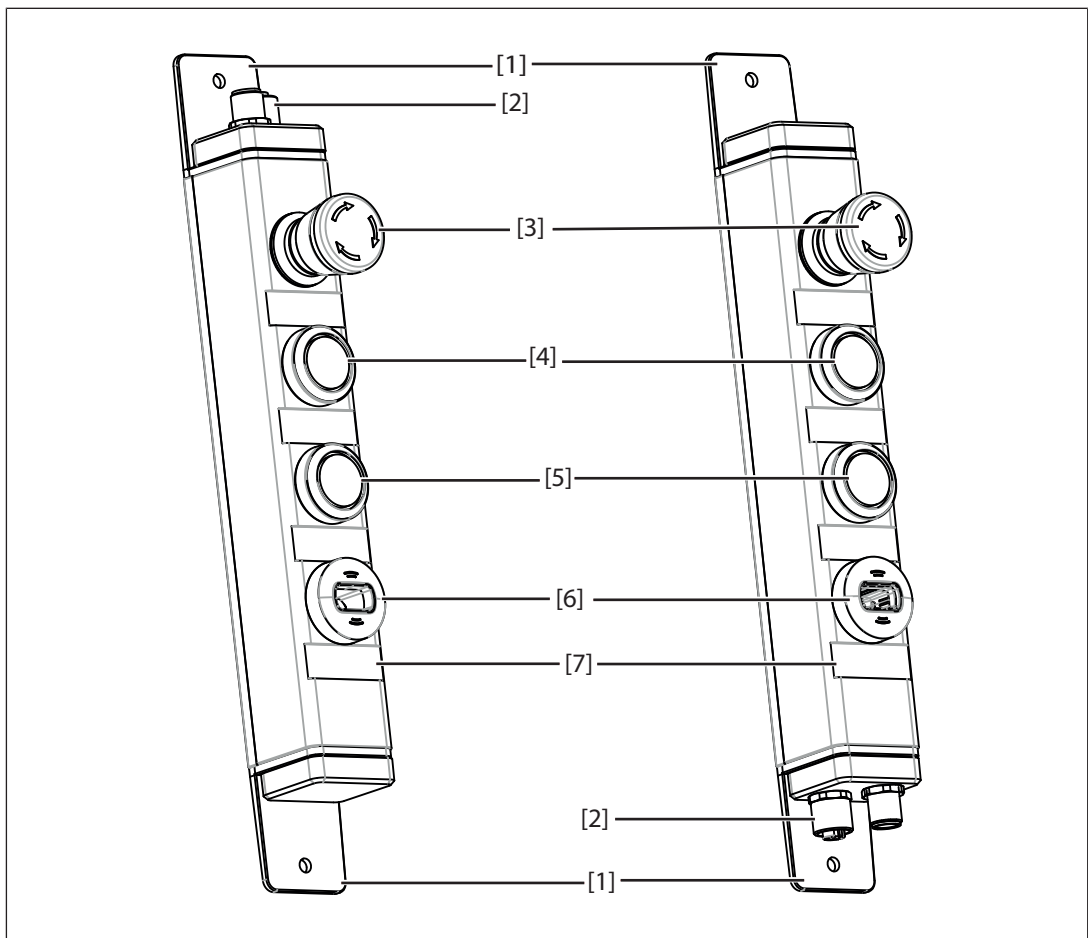

- [1] Rotatable mounting bracket
- [2] M12 connector
- [3] E-STOP pushbutton S4
- [4] Pushbutton S3, illuminated
- [5] Pushbutton S2, illuminated
- [6] PITreader Key S1
- [7] Individual labelling option (width: 35 mm, height: 13 mm)

- ▶ M12 connector [2]

The two M12 connectors [2] used to connect the product are located either on the E-STOP end (PIT gb RLE y up ETH) or on the PITreader end (PIT gb RLE y down ETH).

▶ E-STOP pushbutton S4 [3]

The E-STOP pushbutton S4 [3] is used to shut down plant and machine sections in order to reduce or avert imminent or existing hazards to persons and damage to machinery or materials.

▶ Pushbuttons S2, S3 [5, 4]

- Pushbuttons S2, S3 [5, 4] are used to switch a signal and for status display.
- Pushbuttons S2, S3 [5, 4] light up if the corresponding input is connected.

▶ Pushbutton S2 [5]

- With the pushbutton S2 [5] you can [Reset the password of the PITreader to its default setting](#)  26] during power-up.

▶ PITreader Key S1 [6]

PITreader Key S1 [6] is used for authentication and authorisation on control systems. Authentication is via transponder.

5.1.2 PIT gb with PITreader Card

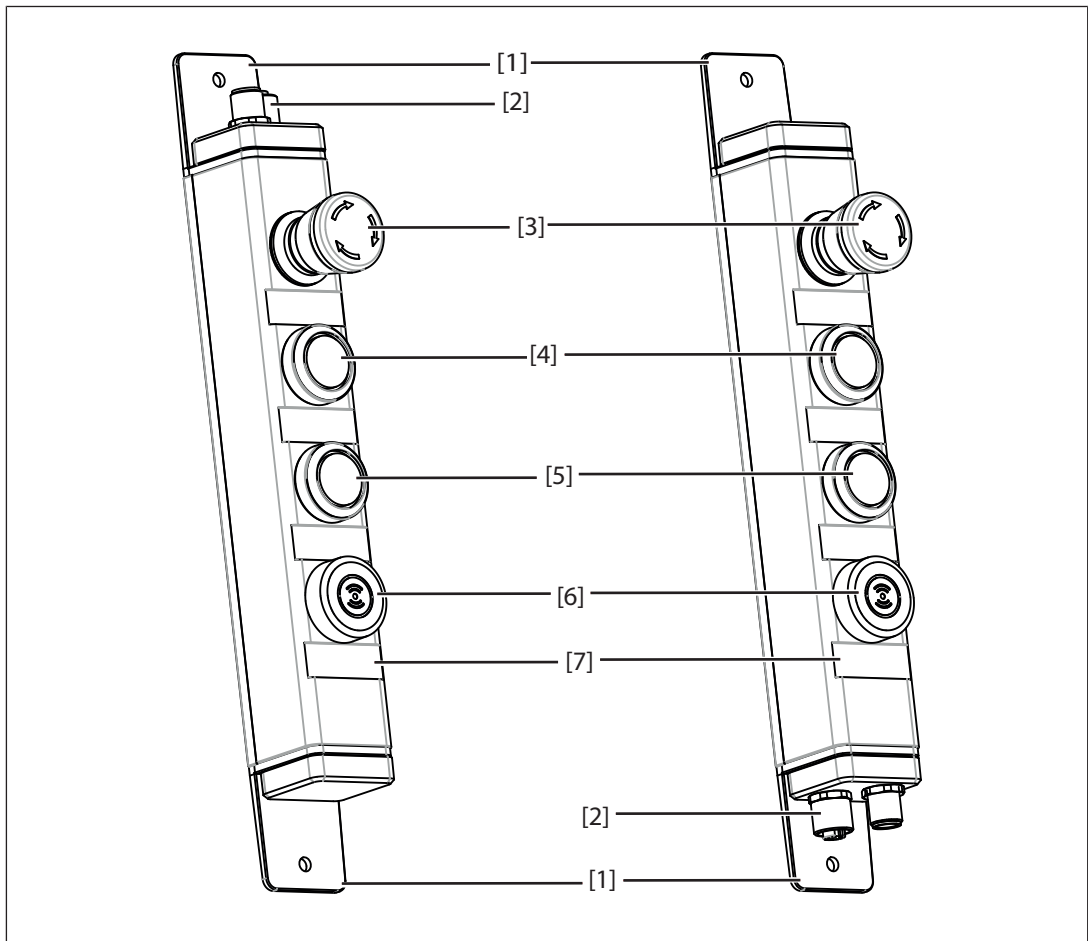

- [1] Rotatable mounting bracket
- [2] M12 connector
- [3] E-STOP pushbutton S4
- [4] Pushbutton S3, illuminated
- [5] Pushbutton S2, illuminated
- [6] PITreader Card S1
- [7] Individual labelling option
(width: 35 mm, height: 13 mm)

► M12 connector [2]

The two M12 connectors [2] used to connect the product are located either on the E-STOP end (PIT gb QLLE y up ETH) or on the PITreader end (PIT gb QLLE y down ETH).

► E-STOP pushbutton S4 [3]

The E-STOP pushbutton S4 [3] is used to shut down plant and machine sections in order to reduce or avert imminent or existing hazards to persons and damage to machinery or materials.

► Pushbuttons S2, S3 [5, 4]

- Pushbuttons S2, S3 [5, 4] are used to switch a signal and for status display.
- Pushbuttons S2, S3 [5, 4] light up if the corresponding input is connected.

- ▶ Pushbutton S2 [5]
 - With the pushbutton S2 [5] you can [Reset the password of the PITreader to its default setting](#) [ 26] during power-up.
- ▶ PITreader Card S1 [6]

The PITreader Card S1 [6] is used for authentication and authorisation on control systems. Authentication is via transponder.

5.2 Block diagram

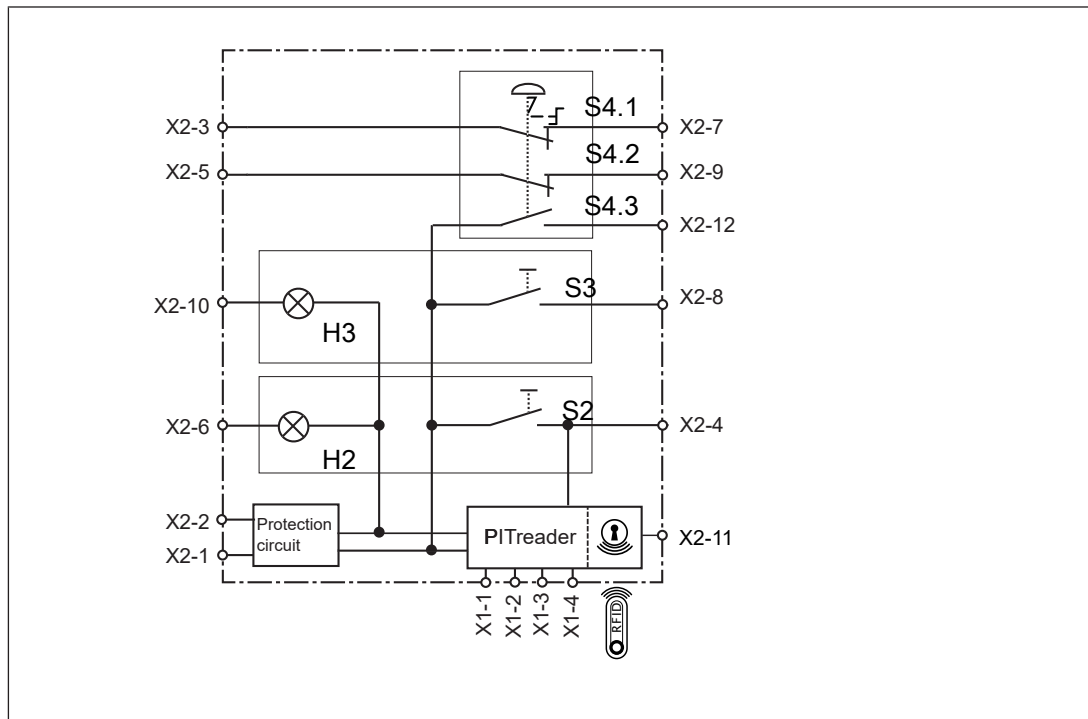

5.3 PITreader

The function of the PITreader authentication system is described in the operating manual for the PITreader (see [Additional documents that apply](#) [ 9]).

The PITreader cannot be connected to PIT m4SEU.

5.4 Coloured caps

The pushbuttons can be marked with coloured caps according to their function (see [Attach coloured cap to pushbutton](#) [ 19]).

6 Installation

6.1 Assembly positions

6.1.1 Potential installation positions of the mounting bracket on PIT gb with PITreader

The mounting brackets used to fasten the PIT gb with PITreader to the mounting surface can be rotated before installing the PIT gb with PITreader, see the following examples for the PIT gb with PITreader Key:

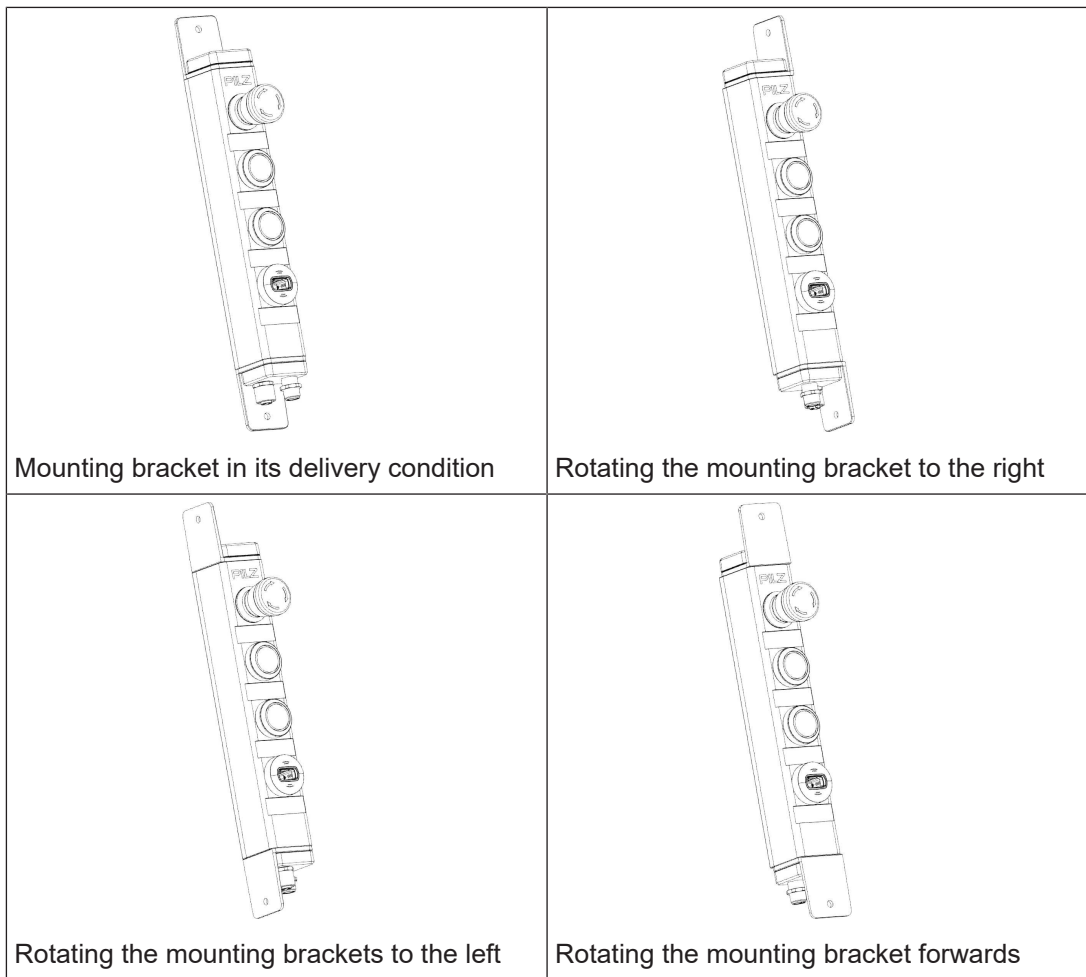

6.1.2 Potential installation positions of the PIT gb with PITreader

The potential installation positions of the PIT gb with PITreader are horizontal and vertical, see the following examples for the PIT gb with PITreader Key:

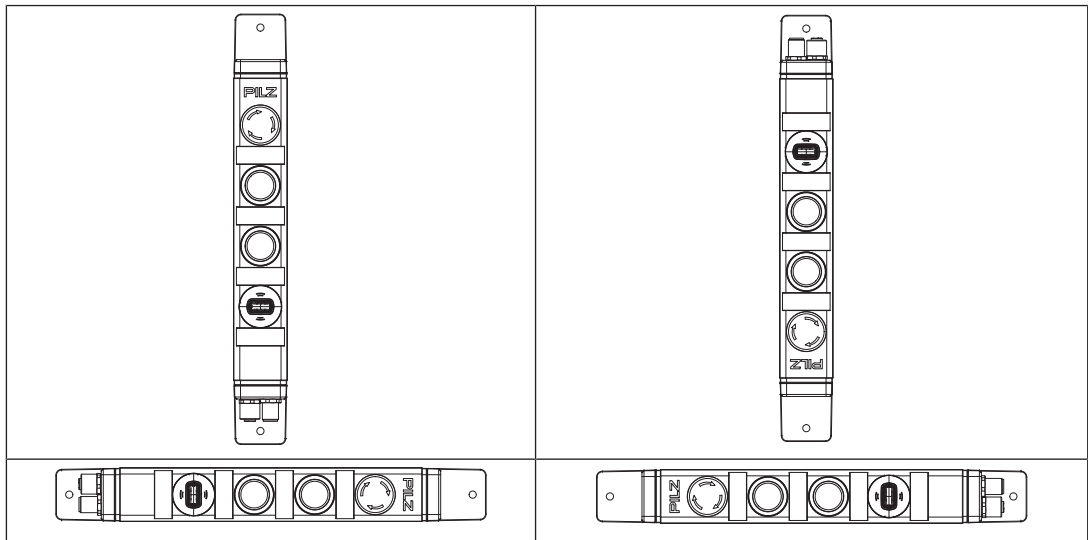

6.2 Installing the product

Note:

- ▶ The PIT gb with PITreader must be installed on a solid surface (e.g. profile, panel).
- ▶ The PIT gb with PITreader must be situated so that it can easily be reached above the access level (e.g. base level, platform level).

The E-STOP pushbutton must be accessible at a height of between 0.6 m to 1.7 m above the access level.

- ▶ The mounting surface must have a max. unevenness of 0.5 mm.
- ▶ The housing of the PIT gb with PITreader must make contact with the mounting surface over at least 5 mm on both ends (see figure).

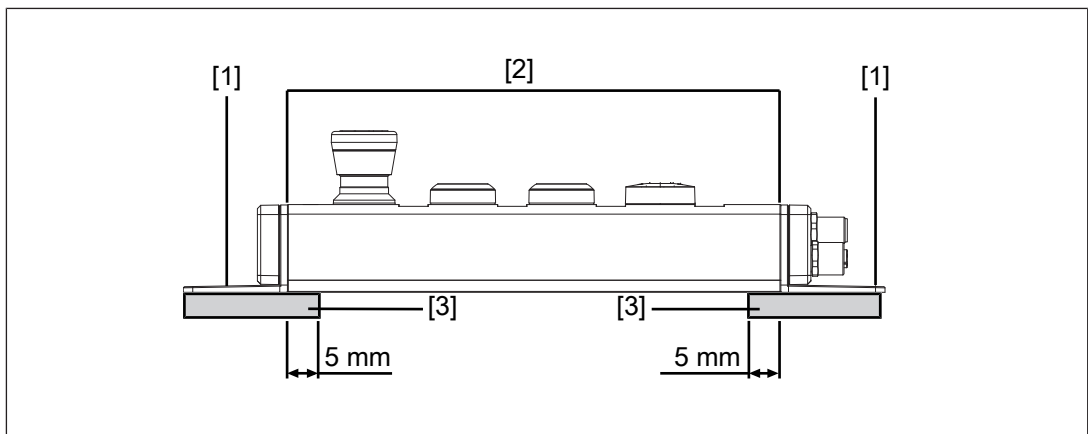

Legend

- [1] Mounting surface
- [2] Mounting bracket
- [3] Housing

- ▶ Use the following to fasten the PIT gb with PITreader:
 - M5 screws
 - M5 washers

Procedure:

1. Provide the mounting surface [1] with drill holes for fastening the PIT gb with PITreader (see [Dimensions](#) [ 29]).
2. Rotate the mounting bracket [2] into the correct position for installation.
3. Fasten the PIT gb with PITreader to the mounting surface [1] and tighten the screws (including washers) with 4 Nm.

6.3 Attach coloured cap to pushbutton

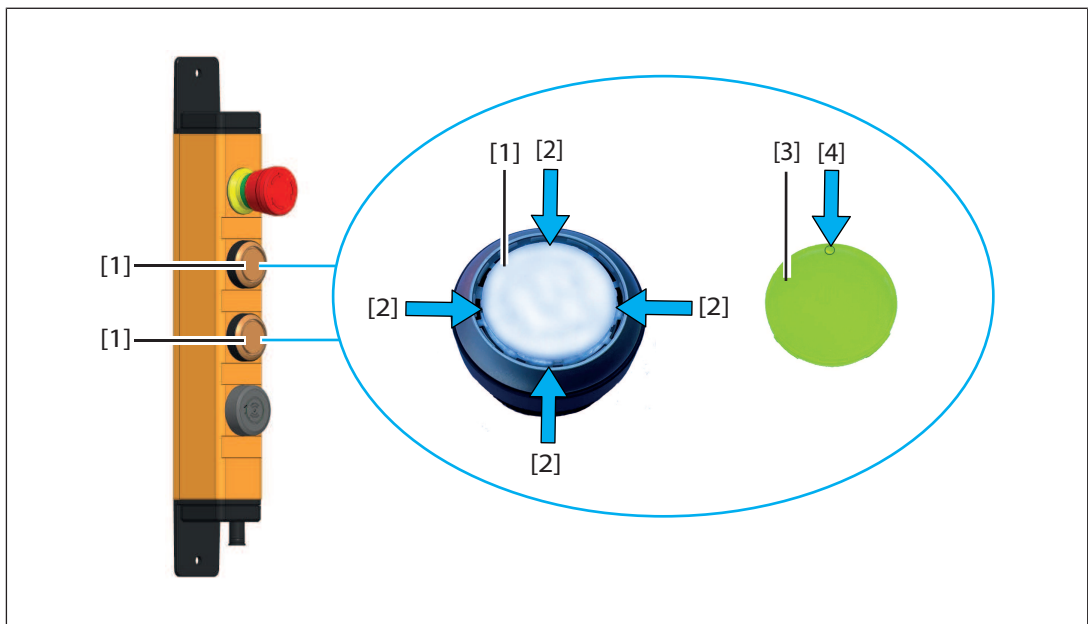

- ▶ Take the required coloured cap from the set provided [3].
- ▶ Place the coloured cap [3] on the required pushbutton [1] so that the alignment marking [4] matches up with one of the positions illustrated [2].

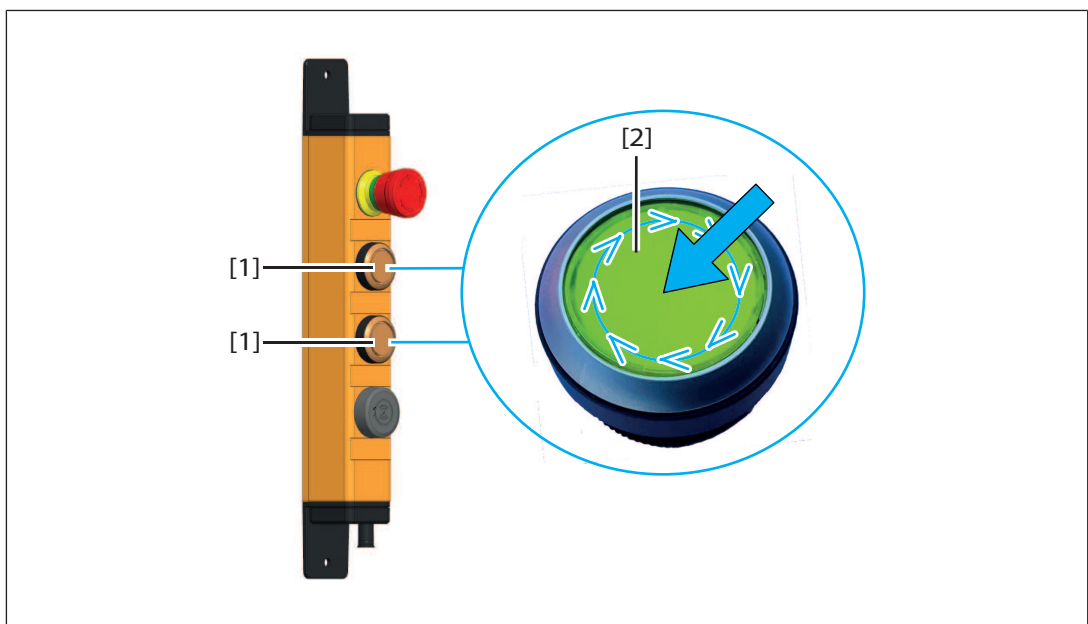

- ▶ Press the coloured cap [2] downwards, as far as it will go. The pushbutton [1] is then pressed.
- ▶ When the pushbutton is pressed [1]: Run your finger around the outer edge of the coloured cap [2] in a circular motion until it clicks into place.

6.4 Installation PITreader card holder

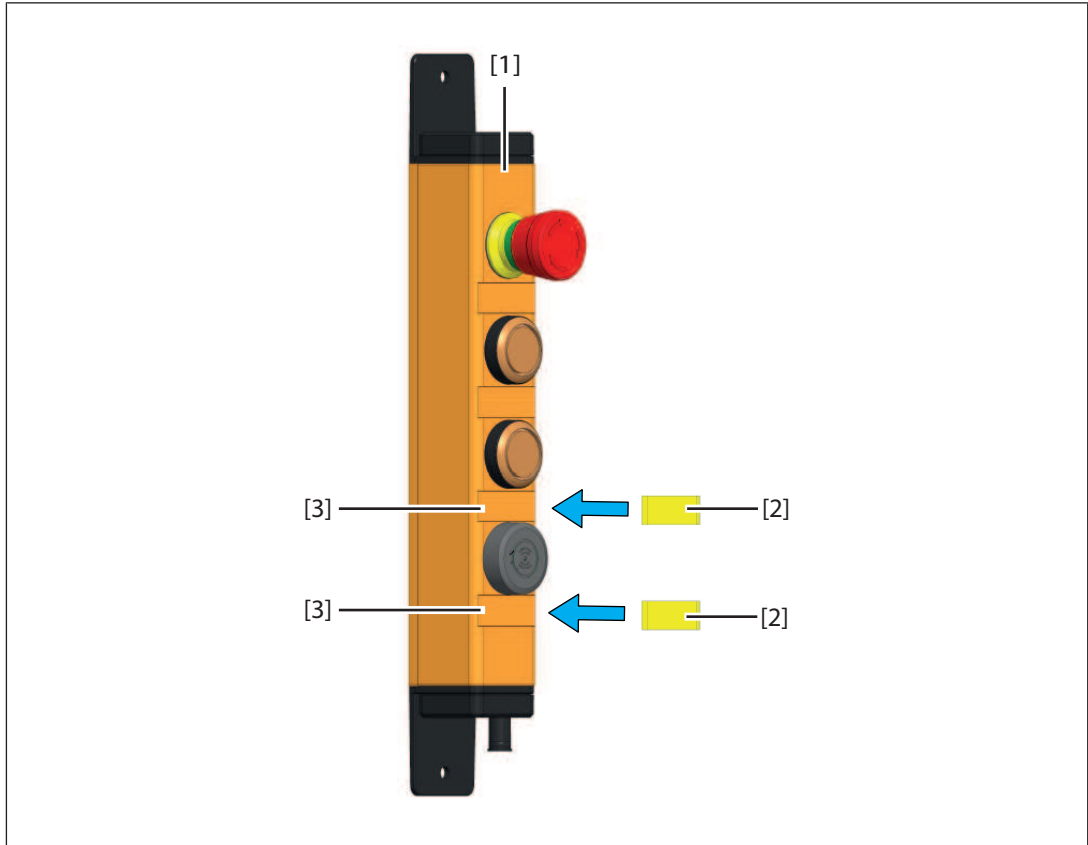

- ▶ Clean the two labelling surfaces [3] on the PIT gb [1]. The adhesive label positions must be smooth and free from dirt, dust and grease.
- ▶ On the first label blank [2], remove the protective film from the adhesive surface.
Do not touch the adhesive surface, to ensure that the adhesive function is not compromised.
- ▶ Press the label blank [2] firmly on to the labelling surface [3].
- ▶ Follow the same procedures for the second label blank [2].

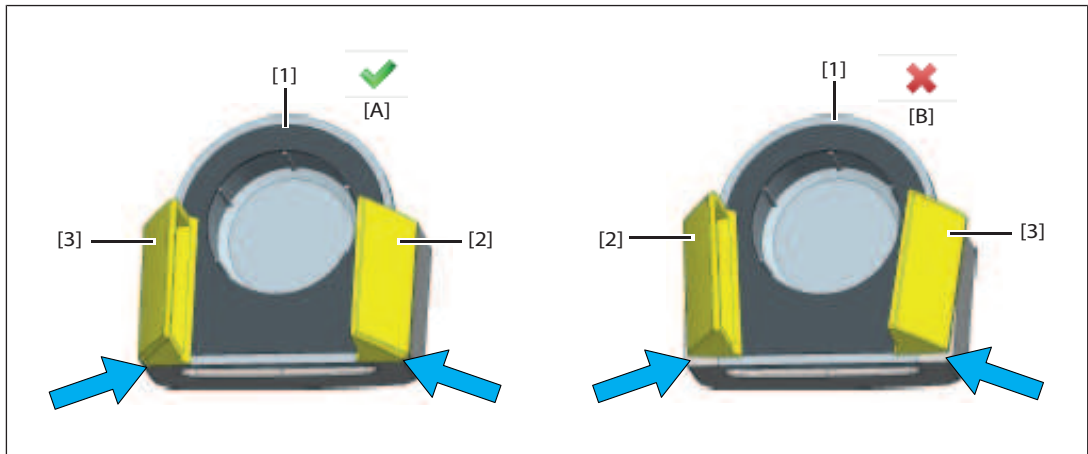

Note:

Please note that the two wings [2, 3] are different [A, B] (arrows).

Once installed [A], the respective underside of the wing must be flush with the underside of the PITreader card holder [1] (arrows).

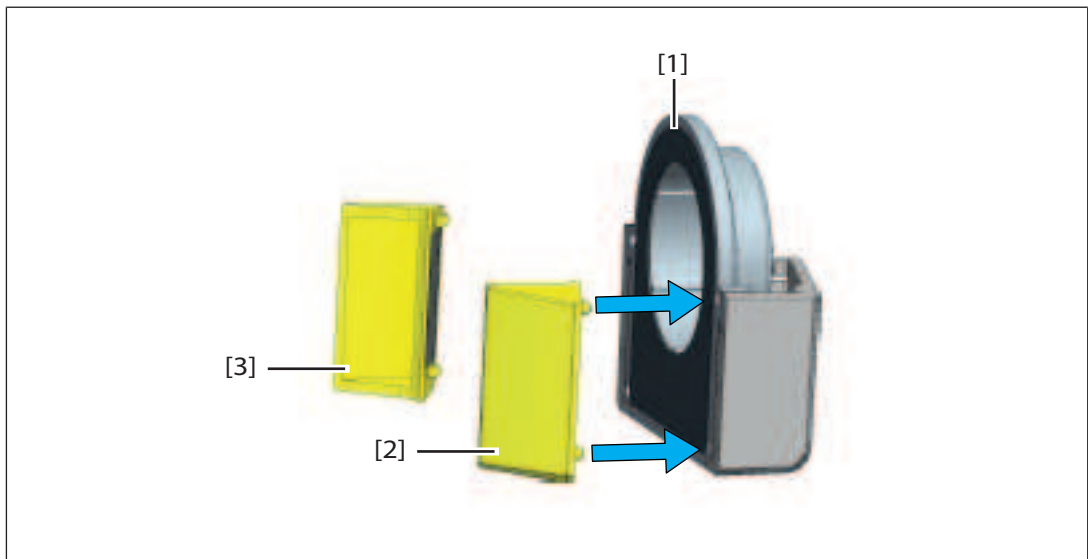

- ▶ Check which of the two wings needs to be attached on the left [3] or right [2] on the PITreader card holder [1]. To do this, take one wing [3] or [2] and insert it with both lugs (arrows) on one side of the PITreader card holder [1].
If both wings [2, 3] are flush with the underside of the PITreader card holder [1], the wings are installed correctly. If not, swap the two wings round [2, 3].
- ▶ Now, on the PITreader card holder [1], remove the protective film from the adhesive surface.
Do not touch the adhesive surface, to ensure that the adhesive function is not compromised.
- ▶ On the first wing, remove the protective film from the adhesive surface and press the wing firmly on to the PITreader card holder [1].
Do not touch the adhesive surface, to ensure that the adhesive function is not compromised.
- ▶ Follow the same procedures for the second wing.

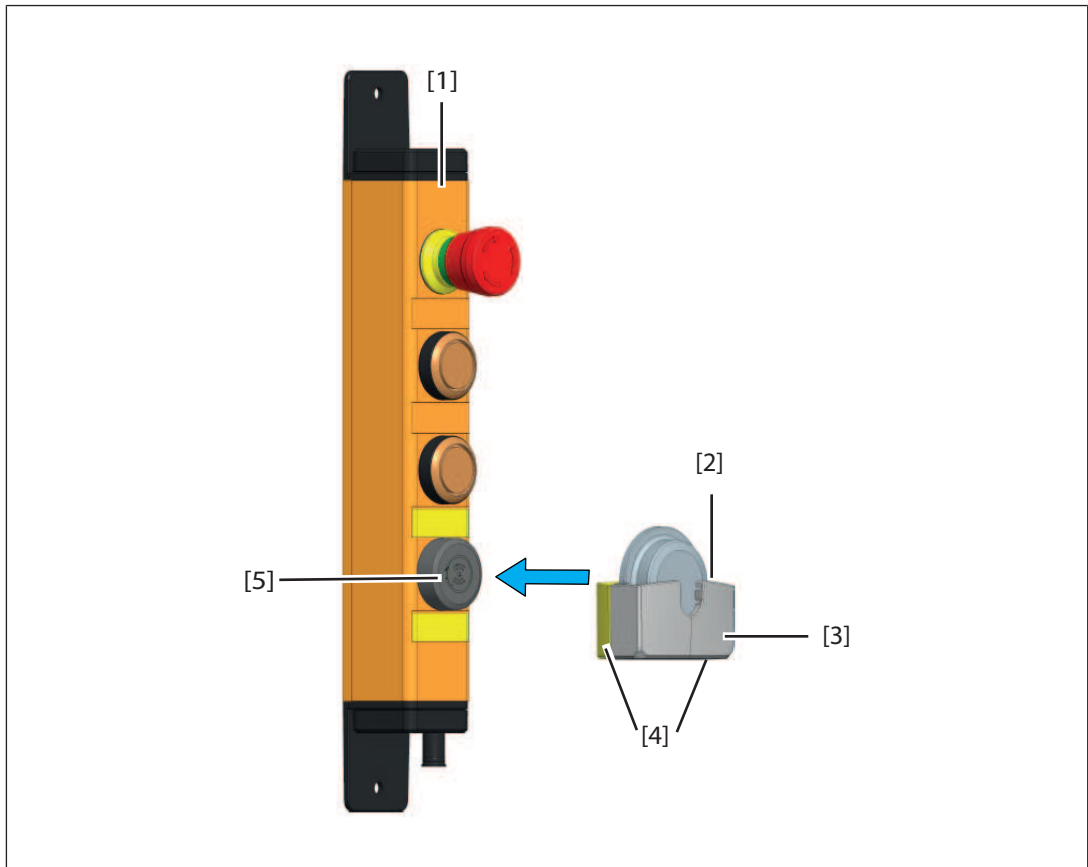



- ▶ Clean the PIT gb housing [1] around the read head [5]. The adhesive position must be smooth and free from dirt, dust and grease.
- ▶ Guide the PITreader card holder [3] so that it is a little above the read head [5]; the opening [2] of the PITreader card holder [3] must face upwards.
Do not touch the adhesive surface, to ensure that the adhesive function is not compromised.
- ▶ Align the PITreader card holder [3] horizontally so that the wings (4) can slide over the housing of the PIT gb [1].
- ▶ Guide the PITreader card holder [3] further over the read head [5] until it fits on the housing of the PIT gb [1].
- ▶ Press the PITreader card holder [3] firmly on to the housing of the PIT gb [1], around the read head [5].

6.5 Attach PITreader transponder sticker

- ▶ Attach transponder sticker, see operating manual for the PITreader.

7 Wiring

Note:

- ▶ Information given in the [Technical details](#) [ 30] must be followed.
- ▶ The power supply must meet the regulations for extra low voltages with protective electrical separation (SELV, PELV).
- ▶ The supply voltage must be fitted with a 4 A fuse, characteristic B/C.
- ▶ Ensure the wiring and EMC requirements of EN 60204-1 are met.
- ▶ Use a 12-pin cable with an A-coded M12 female connector to connect the PIT gb with PITreader to an evaluation device (see [Order reference: Accessories](#) [ 39]).
- ▶ To connect the PIT gb with PITreader to a controller, use a 4-pole cable with a D-coded M12 male connector (see [Order reference: Accessories](#) [ 39]).
- ▶ Route the cables so that they are protected.

7.1 Terminal assignment connectors



NOTICE

The colour marking for the connection lead only applies for the cable that Pilz supplies as an accessory.

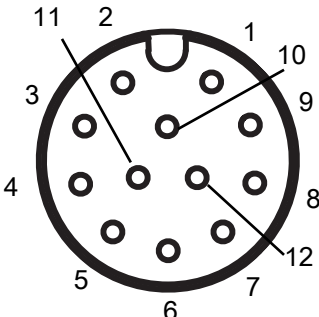
	PIN	Cable colour	Function
 <p>12-pin M12 male connector</p>	1	Brown	+24 V UB
	2	Blue	0 V UB
	3	White	E-STOP channel 1
	4	Green	Pushbutton S2
	5	Pink	E-STOP channel 2
	6	Yellow	LED H2 for pushbutton S2
	7	Black	E-STOP channel 1
	8	Grey	Pushbutton S3
	9	Red	E-STOP channel 2
	10	Purple	LED H3 for pushbutton S3
	11	Grey-pink	Signal output PITreader I0/O0
	12	Red-blue	E-STOP signal contact

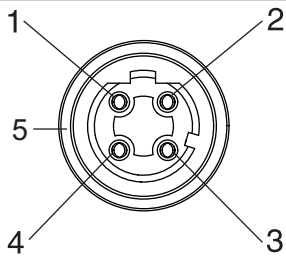
 <p data-bbox="357 524 730 591">4-pin M12 female connector, D-coded</p>	PIN	Cable colour	Function
	1	Brown	TD+, send data
	2	White	RD+, receive data
	3	Blue	TD-, send data
	4	Black	RD-, receive data
	5	-	Connection to the functional earth on the connector hous- ing

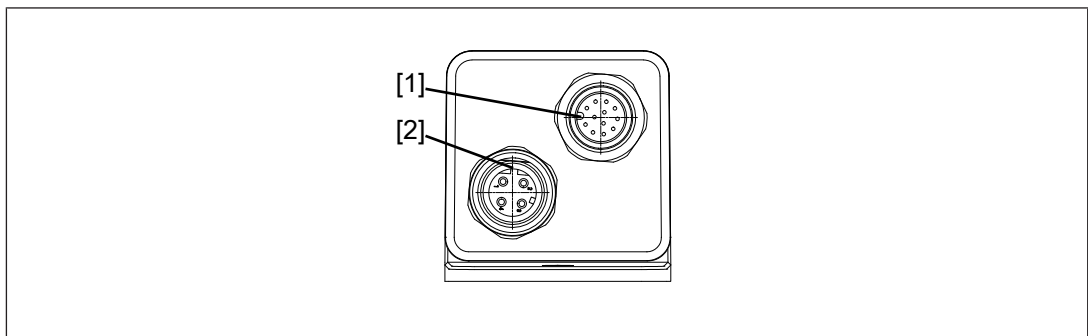

Fig.: View of the PIT gb with PITreader from the connector end:
Position of the coding elements on the connectors to protect the cables from twisting.

Legend

- [1] Coding element on the 12-pin connector
- [2] Coding element on the 4-pin connector

8 Commissioning

8.1 Connection to evaluation device

Suitable Pilz evaluation devices for the actuation of the LED and reading out all control elements include:

- ▶ PNOZmulti
- ▶ PSSuniversal PLC

Suitable Pilz evaluation devices for the evaluation of the E-STOP, for example, are:

- ▶ PNOZelog
- ▶ PNOZsigma
- ▶ PNOZ X

The correct connection to the respective evaluation device is described in the operating manual for the evaluation device. Make sure that the connection is made in accordance with the specifications in the operating manual for the selected evaluation device.

8.2 Configure PITreader

- ▶ Configure the authentication system PITreader, see operating manual for the PITreader.

8.3 Checking the product

Once the product has been installed and aligned, final inspections must be carried out before it can be put into service.



INFORMATION

This inspection may only be carried out by qualified personnel.

- ▶ Check the PIT gb with PITreader for damage.
- ▶ Always test the function with a connected evaluation device.
- ▶ Check the function of the E-STOP.
- ▶ Check the function of the other control elements.

9 Operation

9.1 Display and control elements

The use and display of pushbutton S2 and pushbutton S3 depends on the application in the connected controller.

9.2 PITreader

9.2.1 Position transponder on the PITreader

► Position transponder, see operating manual for the PITreader.

9.2.2 LED display PITreader

A description of the "LED display" can be found in the operating manual for the PITreader.

9.2.3 Firmware update PITreader

The firmware update for the PITreader authentication system is described in the operating manual for the PITreader (see [Additional documents that apply](#)  9).

9.2.4 Reset PITreader to default setting





Procedure:

1. Switch off the supply voltage to the PIT gb with PITreader.
2. Press and hold pushbutton S2.
3. Switch on the supply voltage to the PIT gb with PITreader.
4. When the yellow LED lights up, release pushbutton S2.
5. Press pushbutton S2 again with 10 seconds.

The LED lights up yellow and then green.

The PIT gb with PITreader has been reset successfully.

Status of LEDs on the PITreader when resetting to the factory default settings

Description	Colour	Status
Pushbutton S2 is pressed.	Yellow	
Pushbutton S2 is released.		
Pushbutton S2 is pressed again. The device is reset to the factory default settings.		
The product has successfully been reset to the factory default settings.	Green	

10 Troubleshooting

Fault	Cause	Remedy
LED off	0 V voltage supply not present and/or no signal at corresponding input	<ul style="list-style-type: none"> ▶ Check the wiring of the inputs and outputs ▶ Rectify the wiring error
No output signal with control element operation	24 V voltage supply not present	<ul style="list-style-type: none"> ▶ Check the wiring of the inputs and outputs. ▶ Rectify the wiring error.
Product's function compromised	Connection cable damaged	<ul style="list-style-type: none"> ▶ Check the connection cable. ▶ If necessary, change the connection cable.
Control element damaged	External force	<ul style="list-style-type: none"> ▶ Contact Pilz and arrange a replacement for the product.
LED on the PITreader flashes red	Fault on the PITreader (e.g. hardware error, configuration error, invalid or uncoded transponder key, transponder card or transponder sticker, ...)	<ul style="list-style-type: none"> ▶ Appropriate measures, see LED display PITreader.

11 Maintenance and testing

It is not necessary to perform maintenance work on the product in normal operation.

- ▶ Please return any faulty product to Pilz.

Cleaning

- ▶ Clean the product monthly.
- ▶ Use a soft cloth and mild detergent for cleaning.

Monthly check

- ▶ Perform a manual [function test](#)  25] of the PIT gb with PITreader every month.



INFORMATION

This inspection may only be carried out by qualified personnel.

Check after modifications

- ▶ Inspect the PIT gb with PITreader each time the plant/machine is modified.
Exchanging the PIT gb with PITreader is also to be classed as a modification.
- ▶ During the inspection you **must** comply with the requirements of the applicable national regulations.



INFORMATION

This inspection may only be carried out by qualified personnel.

12 Dimensions

<p>Front view, example of PIT gb with PITreader Key</p>	<p>Side view, example of PIT gb with PITreader Key</p>	<p>Side view, example of PIT gb with PITreader Card</p>
---	--	---

13 Technical details

General	G1000020	G1000021	G1000041	G1000042
Certifications	CE, EAC, FCC, IC, UKCA, UL/cUL	CE, EAC, FCC, IC, UKCA, UL/cUL	CE, EAC, FCC, IC, UKCA, UL/cUL	CE, EAC, FCC, IC, UKCA, UL/cUL
Self-monitored	No	No	No	No
Lamp				
Kind	LED	LED	LED	LED
Colour	White	White	White	White
Transponders	G1000020	G1000021	G1000041	G1000042
Transponder type	Transponder keys	Transponder keys	Transponder card, transponder key, transponder sticker	Transponder card, transponder key, transponder sticker
Electrical data	G1000020	G1000021	G1000041	G1000042
Supply voltage				
Voltage	24 V	24 V	24 V	24 V
Kind	DC	DC	DC	DC
Type of power supply	SELV/PELV	SELV/PELV	SELV/PELV	SELV/PELV
Voltage tolerance	-15 %/+20 %	-15 %/+20 %	-15 %/+20 %	-15 %/+20 %
Output of external power supply (DC)	3,5 W	3,5 W	3,5 W	3,5 W
Duty cycle	100 %	100 %	100 %	100 %
Min. contact current	1 mA	1 mA	1 mA	1 mA
Emergency stop	G1000020	G1000021	G1000041	G1000042
Quantity	1	1	1	1
Number of N/C contacts	2	2	2	2
Number of signal contacts	1	1	1	1
E-STOP release type	Turn release	Turn release	Turn release	Turn release
Utilisation category				
in accordance with the standard	EN 60947-5-1	EN 60947-5-1	EN 60947-5-1	EN 60947-5-1
DC13 at	24 V	24 V	24 V	24 V
Current	0,1 A	0,1 A	0,1 A	0,1 A
Contact material	Ag	Ag	Ag	Ag
Mechanical life	6050 cycles	6050 cycles	6050 cycles	6050 cycles
Pushbutton	G1000020	G1000021	G1000041	G1000042
Quantity	2	2	2	2
Number of N/O contacts	2	2	2	2

Pushbutton	G1000020	G1000021	G1000041	G1000042
Utilisation category				
in accordance with the standard	EN 60947-5-1	EN 60947-5-1	EN 60947-5-1	EN 60947-5-1
DC13 at	24 V	24 V	24 V	24 V
Max. current	0,1 A	0,1 A	0,1 A	0,1 A
Mechanical life	1,000,000 cycles	1,000,000 cycles	1,000,000 cycles	1,000,000 cycles
B10	1,300,000 cycles	1,300,000 cycles	1,300,000 cycles	1,300,000 cycles
Contact material	Ag	Ag	Ag	Ag
PITreader	G1000020	G1000021	G1000041	G1000042
Sensor's mode of operation	Transponders	Transponders	Transponders	Transponders
Transponder's energy supply	passive (battery free)	passive (battery free)	passive (battery free)	passive (battery free)
Frequency band	13,24 - 13,88 MHz	13,24 - 13,88 MHz	13,24 - 13,88 MHz	13,24 - 13,88 MHz
Max. transmitter output	170 mW	170 mW	120 mW	120 mW
Supply interruption before de-energisation	10 ms	10 ms	10 ms	10 ms
Galvanic isolation (semiconductor output)	No	No	No	No
Switching current per semiconductor output	100 mA	100 mA	100 mA	100 mA
Short circuit proof (semiconductor output)	Yes	Yes	Yes	Yes
Signal level at "1" (input)	15 - 30 V DC	15 - 30 V DC	15 - 30 V DC	15 - 30 V DC
Input current range	4 mA	4 mA	4 mA	4 mA
Galvanic isolation (input)	No	No	No	No
MTBF	36 Jahre	36 Jahre	36 Jahre	36 Jahre
Ethernet interface	G1000020	G1000021	G1000041	G1000042
Quantity	1	1	1	1
IP address, factory setting	192.168.0.12	192.168.0.12	192.168.0.12	192.168.0.12
Connection type	M12x1, 4-pin, D-code	M12x1, 4-pin, D-code	M12x1, 4-pin, D-code	M12x1, 4-pin, D-code
Transmission rate	10/100 Mbit/s	10/100 Mbit/s	10/100 Mbit/s	10/100 Mbit/s
Environmental data	G1000020	G1000021	G1000041	G1000042
Ambient temperature				
Temperature range	-20 - 55 °C	-20 - 55 °C	-20 - 55 °C	-20 - 55 °C

Environmental data	G1000020	G1000021	G1000041	G1000042
Storage temperature				
Temperature range	-25 - 70 °C	-25 - 70 °C	-25 - 70 °C	-25 - 70 °C
Climatic suitability				
in accordance with the standard	EN 60068-2-78	EN 60068-2-78	EN 60068-2-78	EN 60068-2-78
Humidity	93 % r. h. at 40 °C	93 % r. h. at 40 °C	93 % r. h. at 40 °C	93 % r. h. at 40 °C
EMC	EN 301489-1 V2.1.1	EN 301489-1 V2.1.1	EN 301489-1 V2.2.3	EN 301489-1 V2.2.3
Vibration				
in accordance with the standard	EN 60947-5-2	EN 60947-5-2	EN 60947-5-2	EN 60947-5-2
Frequency	10 - 55 Hz	10 - 55 Hz	10 - 55 Hz	10 - 55 Hz
Amplitude	1 mm	1 mm	1 mm	1 mm
Shock stress				
in accordance with the standard	EN 60947-5-2	EN 60947-5-2	EN 60947-5-2	EN 60947-5-2
Acceleration	30g	30g	30g	30g
Duration	11 ms	11 ms	11 ms	11 ms
Airgap creepage				
in accordance with the standard	EN 60947-1	EN 60947-1	EN 60947-1	EN 60947-1
Overvoltage category	III	III	III	III
Pollution degree	3	3	3	3
Protection type				
Housing	IP65	IP65	IP64	IP64
in accordance with UL	Type 1	Type 1	Type 1	Type 1
Mechanical data	G1000020	G1000021	G1000041	G1000042
Mounting position	Any	Any	Any	Any
Connection type	M12, 12-pin male connector	M12, 12-pin male connector	M12, 12-pin male connector	M12, 12-pin male connector
Material				
Housing	Zn	Zn	Zn	Zn
Connection type	M12	M12	M12	M12
Fixing screws torque settings	4 Nm	4 Nm	4 Nm	4 Nm
Dimensions				
Height	320 mm	320 mm	320 mm	320 mm
Width	40 mm	40 mm	40 mm	40 mm
Depth	40 mm	40 mm	40 mm	40 mm
Weight	920 g	920 g	920 g	920 g

Where standards are undated, the 2020-08 latest editions shall apply.

13.1 Safety characteristic data



NOTICE

You must comply with the safety characteristic data in order to achieve the required safety level for your plant/machine.

Operating mode	B10d in accordance with EN ISO 13849-1: 2015 and EN 62061
E-STOP with signal contact	130.000

14 Supplementary data

14.1 Radio approvals

14.1.1 PIT gb with PITreader Key

<p><u>USA/Canada</u></p> <p>FCC FCC ID: VT8-PITGB01 IC: 7482A-PITGB01</p> <p><u>FCC/IC-Requirements:</u> This product complies with Part 15 of the FCC Rules and with Industry Canada licence-exempt RSS standards. Operation is subject to the following two conditions: 1) this product may not cause harmful interference, and 2) this product must accept any interference received, including interference that may cause undesired operation.</p> <p>Changes or modifications made to this product not expressly approved by Pilz may void the FCC authorization to operate this equipment.</p> <p>NOTE: This equipment has been tested and found to comply with the limits for a Class A digital device, pursuant to Part 15 of the FCC Rules. These limits are designed to provide reasonable protection against harmful interference when the equipment is operated in a commercial environment. This equipment generates, uses, and can radiate radio frequency energy and, if not installed and used in accordance with the instruction manual, may cause harmful interference to radio communications. Operation of this equipment in a residential area is likely to cause harmful interference in which case the user will be required to correct the interference at his own expense.</p> <p>Le présent produit est conforme aux CNR d'Industrie Canada applicables aux appareils radio exempts de licence. L'exploitation est autorisée aux deux conditions suivantes: (1) le produit ne doit pas produire de brouillage, et (2) l'utilisateur de le produit doit accepter tout brouillage radioélectrique subi, même si le brouillage est susceptible d'en compromettre le fonctionnement.</p>
--

14.1.2 PIT gb with PITreader Card

<p><u>USA/Canada</u></p> <p>FCC FCC ID: VT8-PITGB11 IC: 7482A-PITGB11</p> <p><u>FCC/IC-Requirements:</u> This product complies with Part 15 of the FCC Rules and with Industry Canada licence-exempt RSS standards. Operation is subject to the following two conditions: 1) this product may not cause harmful interference, and 2) this product must accept any interference received, including interference that may cause undesired operation.</p> <p>Changes or modifications made to this product not expressly approved by Pilz may void the FCC authorization to operate this equipment.</p> <p>NOTE: This equipment has been tested and found to comply with the limits for a Class A digital device, pursuant to Part 15 of the FCC Rules. These limits are designed to provide reasonable protection against harmful interference when the equipment is operated in a commercial environment. This equipment generates, uses, and can radiate radio frequency energy and, if not installed and used in accordance with the instruction manual, may cause harmful interference to radio communications. Operation of this equipment in a residential area is likely to cause harmful interference in which case the user will be required to correct the interference at his own expense.</p> <p>Le présent produit est conforme aux CNR d'Industrie Canada applicables aux appareils radio exempts de licence. L'exploitation est autorisée aux deux conditions suivantes: (1) le produit ne doit pas produire de brouillage, et (2) l'utilisateur de le produit doit accepter tout brouillage radioélectrique subi, même si le brouillage est susceptible d'en compromettre le fonctionnement.</p>
--

14.2 Network data

Pro- to- col	Direc- tion [*]	Trans- port protocol	Port no.	Can be deactiv- ated	Description
HTTP	In	TCP	1 ... 65535 Default: 80	Yes	Web application: Browser is always forwarded to HTTPS
HTTPS	In	TCP	1 ... 65535 Default: 443	No	Web application: Transport protection by TLSv1.2. Access to the web application via user name and password. The server is authenticated via an X.509 certificate.
Modbus TCP	In	TCP	1 ... 65535 Default: 502	Yes Default: Inactive	Modbus/TCP Server
NTP	Out	UDP	1 ... 65535 Default: 123	Yes Default: Inactive	SNTP Client
OPC UA	In	TCP	4840	Yes Default: Inactive	PITreader OPC Server UA
mDNS	In	UDP	5353	Yes	Network discovery with Multicast DNS (224.0.0.251)
Multicast configur- ation	In	UDP	7075	Yes	Network configuration via Multicast protocol (239.255.0.12)

[*]

in: The communication partner starts communication with the product.

out: The product starts communication with the communication partner.

15 Order reference

15.1 Product

Product type	Features	Order no.
PIT gb RLLE y up ETH	PITgatebox with PITreader Key (pushbutton unit), housing with E-STOP (2 NC/1 NO), 2 illuminated pushbuttons (1 NO each) and PITreader Key, top connection, M12, 12-pin male connector and M12, 4-pin female connector, Ethernet interface, IP65, 5 coloured caps in GN, BU, RD, YE and transparent	G1000020
PIT gb RLLE y down ETH	PITgatebox with PITreader Key (pushbutton unit), housing with E-STOP (2 NC/1 NO), 2 illuminated pushbuttons (1 NO each) and PITreader Key, bottom connection, M12, 12-pin male connector and M12, 4-pin female connector, Ethernet interface, IP65, 5 coloured caps in GN, BU, RD, YE and transparent	G1000021
PIT gb QLLE y up ETH	PITgatebox with PITreader Card (pushbutton unit), housing with E-STOP (2 NC/1 NO), 2 illuminated pushbuttons (1 NO each) and PITreader Card, top connection, M12, 12-pin male connector and M12, 4-pin female connector, Ethernet interface, IP65, 5 coloured caps in GN, BU, RD, YE and transparent	G1000041
PIT gb QLLE y down ETH	PITgatebox with PITreader Card (pushbutton unit), housing with E-STOP (2 NC/1 NO), 2 illuminated pushbuttons (1 NO each) and PITreader Card, bottom connection, M12, 12-pin male connector and M12, 4-pin female connector, Ethernet interface, IP65, 5 coloured caps in GN, BU, RD, YE and transparent	G1000042

15.2 Transponder key

Product type	Features	Order no.
PITreader key ye g	Transponder key for authentication system PITreader, permissions freely configurable Colour: yellow Material: plastic	402260
PITreader key ye g bk	Generic transponder key for authentication system PITreader, permissions freely configurable Colour: black Material: plastic	402260BK
PITreader key ye g bl	Generic transponder key for authentication system PITreader, permissions freely configurable Colour: blue Material: plastic	402260BL
PITreader key ye g gn	Generic transponder key for authentication system PITreader, permissions freely configurable Colour: green Material: plastic	402260GN
PITreader key ye g rd	Generic transponder key for authentication system PITreader, permissions freely configurable Colour: red Material: plastic	402260RD

Product type	Features	Order no.
PITreader key ye g wt	Generic transponder key for authentication system PITreader, permissions freely configurable Colour: white Material: plastic	402260WT
PITreader key ye g ye	Generic transponder key for authentication system PITreader, permissions freely configurable Colour: light yellow Material: plastic	402260YE
PITreader key ye 1	Transponder key for authentication system PITreader, permission for operating mode 1 Colour: yellow Material: plastic	402261
PITreader key ye 2	Transponder key for authentication system PITreader, permission for operating mode 1 and 2 Colour: yellow Material: plastic	402262
PITreader key ye 3	Transponder key for authentication system PITreader, permission for operating mode 1, 2 and 3 Colour: yellow Material: plastic	402263
PITreader key ye 4	Transponder key for authentication system PITreader, permission for operating mode 1, 2, 3 and 4 Colour: yellow Material: plastic	402264
PITreader key ye 5	Transponder key for authentication system PITreader, permission for operating mode 1, 2, 3, 4 and 5 Colour: yellow Material: plastic	402265
PITreader key ye 5 service	Transponder key for authentication system PITreader, permission for operating mode 1, 2, 3, 4 and 5 (Service) Colour: yellow Material: plastic	402269

15.3 Transponder cards

Product type	Features	Order no.
PITreader card ye g	Transponder card for authentication system PITreader Card, permissions freely configurable Colour: yellow Material: plastic	402330
PITreader card ye 1	Transponder card for authentication system PITreader Card, permission for operating mode 1 Colour: yellow Material: plastic	402331
PITreader card ye 2	Transponder card for authentication system PITreader Card, permission for operating mode 1 and 2 Colour: yellow Material: plastic	402332

Product type	Features	Order no.
PITreader card ye 3	Transponder card for authentication system PITreader Card, permission for operating mode 1, 2 and 3 Colour: yellow Material: plastic	402333
PITreader card ye 4	Transponder card for authentication system PITreader Card, permission for operating mode 1, 2, 3 and 4 Colour: yellow Material: plastic	402334
PITreader card ye 5	Transponder card for authentication system PITreader Card, permission for operating mode 1, 2, 3, 4 and 5 Colour: yellow Material: plastic	402335
PITreader card ye 5 service	Transponder card for authentication system PITreader Card, permission for operating mode 1, 2, 3, 4 and 5 (Service) Colour: yellow Material: plastic	402339

15.4 Transponder sticker

Product type	Features	Order no.
PITreader sticker ye 9	Transponder sticker for authentication system PITreader Card, permissions freely configurable Colour: yellow Material: plastic	402340
PITreader sticker ye 1	Transponder sticker for authentication system PITreader Card, permission for operating mode 1 Colour: yellow Material: plastic	402341
PITreader sticker ye 2	Transponder sticker for authentication system PITreader Card, permission for operating mode 1 and 2 Colour: yellow Material: plastic	402342
PITreader sticker ye 3	Transponder sticker for authentication system PITreader Card, permission for operating mode 1, 2 and 3 Colour: yellow Material: plastic	402343
PITreader sticker ye 4	Transponder sticker for authentication system PITreader Card, permission for operating mode 1, 2, 3 and 4 Colour: yellow Material: plastic	402344
PITreader sticker ye 5	Transponder sticker for authentication system PITreader Card, permission for operating mode 1, 2, 3, 4 and 5 Colour: yellow Material: plastic	402345
PITreader sticker ye 5 service	Transponder sticker for authentication system PITreader Card, permission for operating mode 1, 2, 3, 4 and 5 (Service) Colour: yellow Material: plastic	402349

15.5 Accessories

Coloured caps

Product type	Features	Order no.
PIT gb color covers	Colour covers for the illuminated pushbuttons (set)	G1000009
PIT gb color cover wh s1	Colour covers for the illuminated pushbuttons, white, IEC symbol Start	G1000013
PIT gb color cover wh s2	Colour covers for the illuminated pushbuttons, white, IEC symbol ON	G1000014
PIT gb color cover wh s3	Colour covers for the illuminated pushbuttons, white, IEC symbol Unlocking	G1000015
PIT gb color cover wh s4	Colour covers for the illuminated pushbuttons, white, IEC symbol Locking	G1000016
PIT gb color cover bl s5	Colour covers for the illuminated pushbuttons, blue, IEC symbol Request	G1000017
PIT gb color cover bl s6	Colour covers for the illuminated pushbuttons, blue, IEC symbol Reset	G1000018
PIT gb color cover bl s4	Colour covers for the illuminated pushbuttons, blue, IEC symbol Locking	G1000019

PITgatebox card holder

Product type	Features	Order no.
PITgatebox card holder	Transponder mounting for the authentication system PITreader Card on the PITgatebox	402324

Cable

Product type	Features	Connector X1	Connector X2	Connector X3	Order no.
PSEN cable M12-12sf 2m	2 m	M12, 12-pin female connector, straight			570350
PSEN cable M12-12sf 3m	3 m	M12, 12-pin female connector, straight			570351
PSEN cable M12-12sf 5m	5 m	M12, 12-pin female connector, straight			570352
PSEN cable M12-12sf 10m	10 m	M12, 12-pin female connector, straight			570353
PSEN cable M12-12sf 20m	20 m	M12, 12-pin female connector, straight			570354
PSEN cable M12-12sf 30m	30 m	M12, 12-pin female connector, straight			570355

Product type	Features	Connector X1	Connector X2	Connector X3	Order no.
PSEN cable M12-12sf 50m	50 m	M12, 12-pin female connector, straight			570356
PSEN cable M12-12sf/ M12-12sm 1m	1 m	M12, 12-pin female connector, straight	M12, 12-pin male connector, straight		570357
PSEN cable M12-12sf/ M12-12sm 2m	2 m	M12, 12-pin female connector, straight	M12, 12-pin male connector, straight		570358
PSEN cable M12-12sf/ M12-12sm 3m	3 m	M12, 12-pin female connector, straight	M12, 12-pin male connector, straight		570359
PSEN cable M12-12sf/ M12-12sm 5m	5 m	M12, 12-pin female connector, straight	M12, 12-pin male connector, straight		570360
PSEN cable M12-12sf/ M12-12sm 10m	10 m	M12, 12-pin female connector, straight	M12, 12-pin male connector, straight		570361
PSEN cable M12-12sf/ M12-12sm 20m	20 m	M12, 12-pin female connector, straight	M12, 12-pin male connector, straight		570362
SafetyNET p cable	By the metre, 4-pin. CAT5e				380000

Connector

Product type	Features	Connector X1	Connector X2	Connector X3	Order no.
M12 con., straight, male, 4-pin, D	D-coded	M12, 4-pin male connector, straight			380316
SafetyNET p connector RJ45s		4-pin RJ45 male connector, straight, Cat 5a			380400

16 **EC declaration of conformity**

This product/these products meet(s) the requirements of the following directives of the European Parliament and of the Council.

- ▶ 2006/42/EC on machines
- ▶ 2014/53/EU on radio equipment

The complete EC Declaration of Conformity is available on the Internet at www.pilz.com/downloads.

Representative: Pilz GmbH & Co. KG, Felix-Wankel-Str. 2, 73760 Ostfildern, Germany

17 UKCA-Declaration of Conformity

This product(s) complies with following UK legislation:

- ▶ Supply of Machinery (Safety) Regulations 2008
- ▶ Radio Equipment Regulations 2017

The complete UKCA Declaration of Conformity is available on the Internet at www.pilz.com/downloads.

Representative: Pilz Automation Technology, Pilz House, Little Colliers Field,
Corby, Northamptonshire, NN18 8TJ United Kingdom, eMail: mail@pilz.co.uk

► Support

Technical support is available from Pilz round the clock.

Americas

Brazil

+55 11 97569-2804

Canada

+1 888 315 7459

Mexico

+52 55 5572 1300

USA (toll-free)

+1 877-PILZUSA (745-9872)

Asia

China

+86 400-088-3566

Japan

+81 45 471-2281

South Korea

+82 31 778 3300

Australia and Oceania

Australia

+61 3 95600621

New Zealand

+64 9 6345350

Europe

Austria

+43 1 7986263-444

Belgium, Luxembourg

+32 9 3217570

France

+33 3 88104003

Germany

+49 711 3409-444

Ireland

+353 21 4804983

Italy, Malta

+39 0362 1826711

Scandinavia

+45 74436332

Spain

+34 938497433

Switzerland

+41 62 88979-32

The Netherlands

+31 347 320477

Türkiye

+90 216 5775552

United Kingdom

+44 1536 462203

You can reach our international hotline on:

+49 711 3409-222

support@pilz.com

Pilz develops environmentally-friendly products using ecological materials and energy-saving technologies. Offices and production facilities are ecologically designed, environmentally-aware and energy-saving. So Pilz offers sustainability, plus the security of using energy-efficient products and environmentally-friendly solutions.



We are represented internationally. Please refer to our homepage www.pilz.com for further details or contact our headquarters.

Headquarters: Pilz GmbH & Co. KG, Felix-Wankel-Straße 2, 73760 Ostfildern, Germany
Telephone: +49 711 3409-0, E-Mail: info@pilz.com, Internet: www.pilz.com

PILZ
THE SPIRIT OF SAFETY

CECE[®], CHRE[®], CMSE[®], INDUSTRIAL P[®], Leansafe[®], Myzel[®], PAS4000[®], PASscal[®], PASconfig[®], Pilz[®], PIT[®], PMSprimo[®], PMSprotego[®], PMCiendo[®], PMD[®], PMI[®], PNOZ[®], Primo[®], PSEN[®], PSEN[®], PSS[®], PVS[®], SafetyBUS p[®], SafetyNET p[®], THE SPIRIT OF SAFETY[®] are registered and protected trademarks of Pilz GmbH & Co. KG in some countries. We would point out that product features may vary from the details stated in this document, depending on the status at the time of publication and the scope of the equipment. We accept no responsibility for the validity, accuracy and entirety of the text and graphics presented in this information. Please contact our Technical Support if you have any questions.

1005249-EN-02, 2024-07 Printed in Germany
© Pilz GmbH & Co. KG, 2019