

Technical description EBI10-system

Date: 31.07.2018
Device: EBI10 System, Parts EBI 10 (EBI100) and EBI 12 (16)
Author: Stephan Kirschner, R&D dept.

Overview:

This document describes the similarities and differences of CPU-PCB and RFID-PCB between Part EBI10 (EBI100) and Part EBI12 (EBI16)

Technical description EBI10-system

Similarities:

Part EBI10 (EBI100) and Part EBI12 CPU-PCB is using CC2420 for 2.4GHz communication.

HF circuit is not changed.

Antenna design for 2.4GHz is not changed.

Parts used for antenna circuit (capacitors and inductors) are not changed.

13.56MHz antenna is only used for receiving, no data signal is sent out.

Differences:

13.56MHz radio:

RFID board V2.2 was not changed. Old wired antenna was replaced with a new one which is now directly welded on the RFID board.

old antenna:

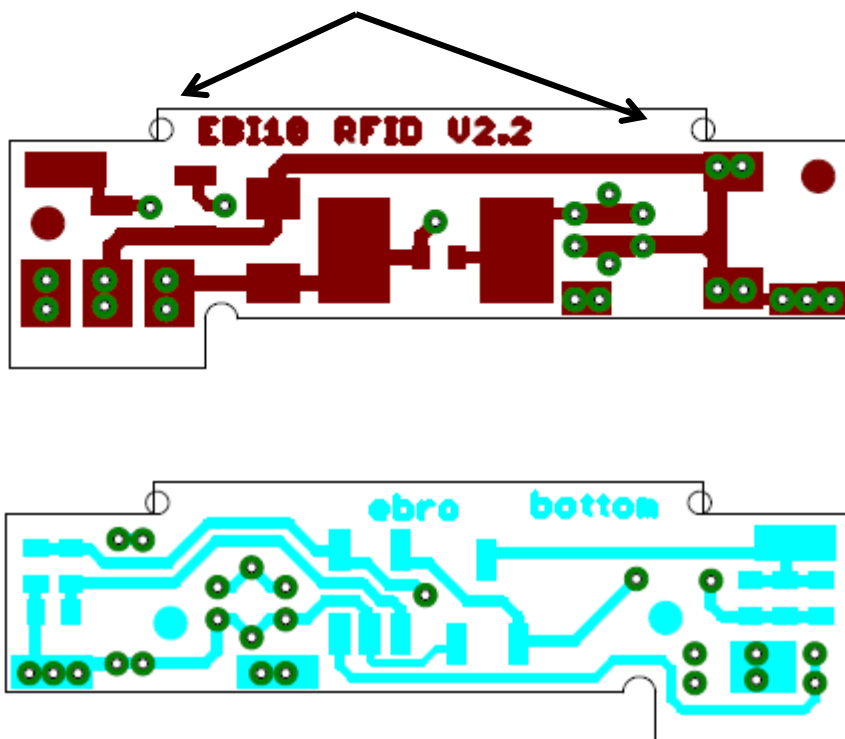

Technical description EBI10-system

new antenna:

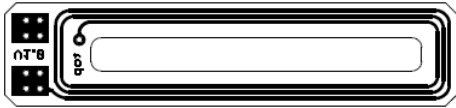

Top view

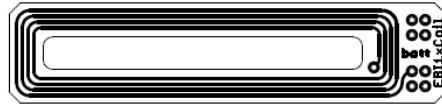

Bottom view



old wired RFID antenna



new antenna



old wired RFID antenna

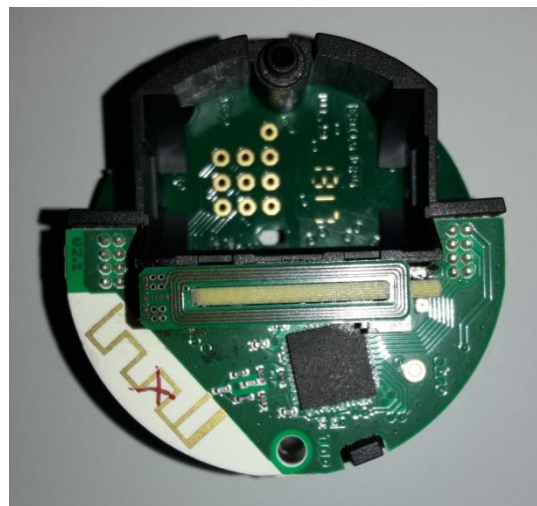

new antenna

Technical description EBI10-system

CPU-PCB:

A second analog Multiplexer was added to get more sensor channels.

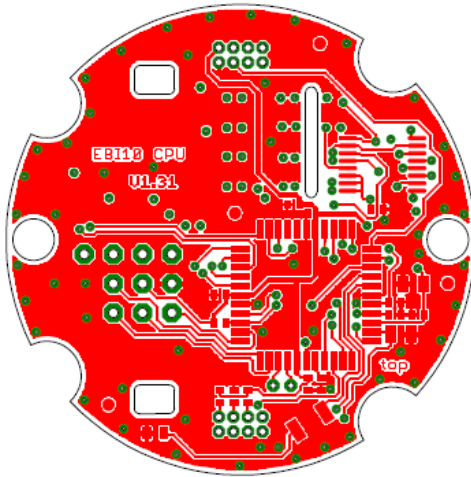

old CPU-PCB Top view

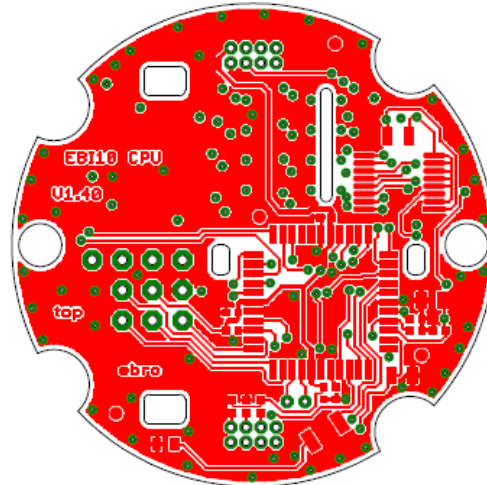

new CPU-PCB Top view

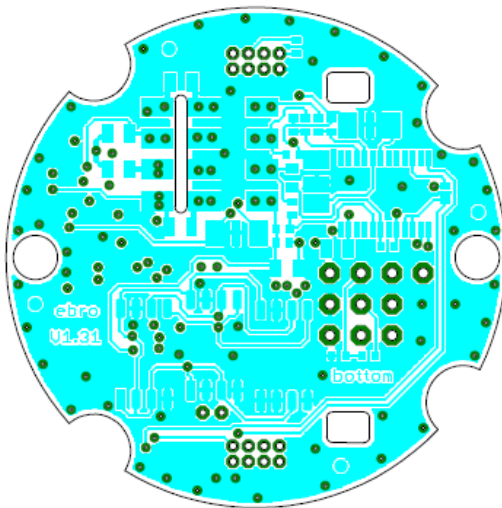

old CPU-PCB Bottom view

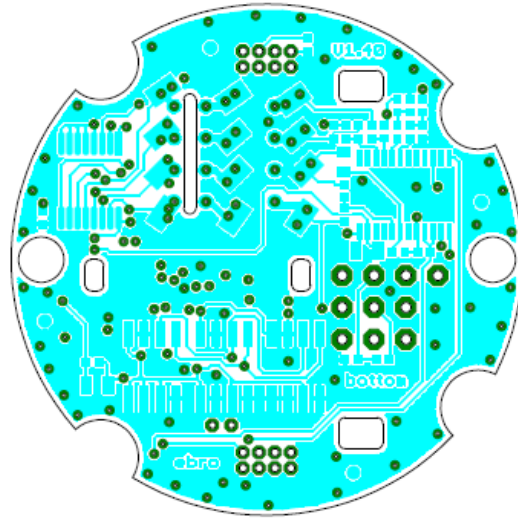

new CPU-PCB Bottom view

Housing:

Part EBI10 (EBI100) has a plain metal housing, Part EBI12 (EBI16) has a plain metal housing with recessed grip.