



**FCC CFR47 PART 15 SUBPART C
INDUSTRY CANADA RSS-247 ISSUE 2**

Bluetooth Low Energy

CERTIFICATION TEST REPORT

FOR

Modem

MODEL NUMBER : DR-X1MAX

FCC ID: VA5CMT248-X1MAX

IC : 7087A-CMT248X1M

REPORT NUMBER: 4788917538-E1V2

ISSUE DATE: APR 11, 2019

Prepared for

SEGI LIMITED

**Unit J2, 4/F, Block 1, Kinho Industrial Building,
14-24 Au Pui Wan Street, Shatin, New Territories
HONGKONG, China**

Prepared by

UL Korea, Ltd.

26th floor, 152, Teheran-ro, Gangnam-gu Seoul, 06236, Korea

Suwon Test Site: UL Korea, Ltd. Suwon Laboratory

**218 Maeyeong-ro, Yeongtong-gu,
Suwon-si, Gyeonggi-do, 16675, Korea**

TEL: (031) 337-9902

FAX: (031) 213-5433



ACCREDITED*

Testing
Laboratory

TL-637

Revision History

<u>Rev.</u>	<u>Issue Date</u>	<u>Revisions</u>	<u>Revised By</u>
V1	03/22/19	Initial issue	Hoonpyo Lee
V2	04/11/19	Updated to address about the TCB's question	Hoonpyo Lee

TABLE OF CONTENTS

1. ATTESTATION OF TEST RESULTS	5
2. TEST METHODOLOGY	6
3. FACILITIES AND ACCREDITATION	6
4. CALIBRATION AND UNCERTAINTY	6
4.1. MEASURING INSTRUMENT CALIBRATION.....	6
4.2. SAMPLE CALCULATION.....	6
4.3. MEASUREMENT UNCERTAINTY	7
5. EQUIPMENT UNDER TEST	8
5.1. DESCRIPTION OF EUT.....	8
5.2. MAXIMUM OUTPUT POWER.....	8
5.3. DESCRIPTION OF AVAILABLE ANTENNAS	8
5.4. WORST-CASE CONFIGURATION AND MODE	9
5.5. DESCRIPTION OF TEST SETUP	10
6. TEST AND MEASUREMENT EQUIPMENT	12
7. REFERENCE MEASUREMENT RESULTS.....	13
7.1. ON TIME AND DUTY CYCLE RESULTS.....	13
7.2. 99% BANDWIDTH	14
8. MEASUREMENT METHODS	16
9. SUMMARY TABLE	17
10. ANTENNA PORT TEST RESULTS.....	18
10.1. 6 dB BANDWIDTH.....	18
10.2. OUTPUT POWER.....	20
10.3. AVERAGE POWER.....	22
10.4. PSD	23
10.5. OUT-OF-BAND EMISSIONS	25
11. RADIATED TEST RESULTS.....	29
11.1. LIMITS AND PROCEDURE	29
11.2. TRANSMITTER ABOVE 1 GHz	31
11.2.1. 1Mbps MODE	31
11.3. WORST-CASE BELOW 1 GHz.....	41

12. AC POWER LINE CONDUCTED EMISSIONS43

13. SETUP PHOTOS.....44

1. ATTESTATION OF TEST RESULTS

COMPANY NAME: SAMSUNG ELECTRONICS CO., LTD.
EUT DESCRIPTION: Modem
MODEL NUMBER: DR-X1MAX
SERIAL NUMBER: Prototype_#6 (RADIATED);
Prototype_#8 (CONDUCTED)
DATE TESTED: FEB 25, 2019 - MAR 21, 2019

APPLICABLE STANDARDS	
STANDARD	TEST RESULTS
CFR 47 Part 15 Subpart C	Pass
INDUSTRY CANADA RSS-247 Issue 2	Pass
INDUSTRY CANADA RSS-GEN Issue 5	Pass

UL Korea, Ltd. tested the above equipment in accordance with the requirements set forth in the above standards. All indications of Pass/Fail in this report are opinions expressed by UL Korea, Ltd. based on interpretations and/or observations of test results. Measurement Uncertainties were not taken into account and are published for informational purposes only. The test results show that the equipment tested is capable of demonstrating compliance with the requirements as documented in this report.

Note: The results documented in this report apply only to the tested sample, under the conditions and modes of operation as described herein. This document JUN not be altered or revised in any way unless done so by UL Korea, Ltd. and all revisions are duly noted in the revisions section. Any alteration of this document not carried out by UL Korea, Ltd. will constitute fraud and shall nullify the document. This report must not be used by the client to claim product certification, approval, or endorsement by IAS, any agency of the Federal Government, or any agency of any government.

Approved & Released For
UL Korea, Ltd. By:



SungGil Park
Suwon Lab Engineer
UL Korea, Ltd.

Tested By:



Hoonpyo Lee
Suwon Lab Engineer
UL Korea, Ltd.

2. TEST METHODOLOGY

The tests documented in this report were performed in accordance with following methods.

1. FCC CFR 47 Part 2.
2. FCC CFR 47 Part 15.
3. IC RSS-GEN Issue 5
4. IC RSS-247 Issue 2
5. KDB 558074 D01 15.247 Meas Guidance v05r02.
6. ANSI C63.10-2013.

3. FACILITIES AND ACCREDITATION

The test sites and measurement facilities used to collect data are located at 218 Maeyeong-ro, Yeongtong-gu, Suwon-si, Gyeonggi-do, 16675, Korea. Line conducted emissions are measured only at the 218 address. The following table identifies which facilities were utilized for radiated emission measurements documented in this report. Specific facilities are also identified in the test results sections.

218 Maeyeong-ro	
<input checked="" type="checkbox"/>	Chamber 1
<input checked="" type="checkbox"/>	Chamber 2
<input type="checkbox"/>	Chamber 3

UL Korea, Ltd. is accredited by IAS, Laboratory Code TL-637. The full scope of accreditation can be viewed at <http://www.iasonline.org/PDF/TL/TL-637.pdf>.

4. CALIBRATION AND UNCERTAINTY

4.1. MEASURING INSTRUMENT CALIBRATION

The measuring equipment utilized to perform the tests documented in this report has been calibrated in accordance with the manufacturer's recommendations, and is traceable to recognized national standards.

4.2. SAMPLE CALCULATION

Where relevant, the following sample calculation is provided:

$$\begin{aligned} \text{Field Strength (dBuV/m)} &= \text{Measured Voltage (dBuV)} + \text{Antenna Factor (dB/m)} + \\ &\text{Cable Loss (dB)} - \text{Preamp Gain (dB)} \\ 36.5 \text{ dBuV} + 18.7 \text{ dB/m} + 0.6 \text{ dB} - 26.9 \text{ dB} &= 28.9 \text{ dBuV/m} \end{aligned}$$

4.3. MEASUREMENT UNCERTAINTY

Where relevant, the following measurement uncertainty levels have been estimated for tests performed on the apparatus:

PARAMETER	UNCERTAINTY
Conducted Disturbance, 0.15 to 30 MHz	2.32 dB
Radiated Disturbance, Below 1GHz	3.86 dB
Radiated Disturbance, Above 1 GHz	5.97 dB

Uncertainty figures are valid to a confidence level of 95%.

5. EQUIPMENT UNDER TEST

5.1. DESCRIPTION OF EUT

The EUT is a Modem.

This test report addresses the DTS (BLE) operational mode.

5.2. MAXIMUM OUTPUT POWER

The transmitter has a maximum total conducted output power as follows:

Frequency Range [MHz]	Mode	Power Mode	Output Power [dBm]	Output Power [mW]
2402 - 2480	1Mbps	Peak	5.831	3.83
		Average	5.572	3.61

5.3. DESCRIPTION OF AVAILABLE ANTENNAS

The radio utilizes an internal antenna, with a maximum gain of 1.99 dBi.

5.4. WORST-CASE CONFIGURATION AND MODE

Radiated emission below 1GHz were performed with the EUT set to transmit at the channel with highest output power as worst-case scenario.

Radiated emission above 1GHz was performed with the EUT set to transmit low/mid/high channels.

The fundamental of the EUT was investigated in three orthogonal orientations X, Y and Z it was determined that X orientation was worst-case orientation; therefore, all final radiated testing was performed with the EUT in X orientation.

5.5. DESCRIPTION OF TEST SETUP

SUPPORT EQUIPMENT

Support Equipment List				
Description	Manufacturer	Model	Serial Number	FCC ID
None	None	None	None	None

I/O CABLE

I/O Cable List						
Cable No	Port	# of identical ports	Connector Type	Cable Type	Cable Length (m)	Remarks
1	DC Power	1	4pin	Unshielded	1.1m	N/A
2	Serial	2	Soldering	Unshielded	0.2m	For connect JIG

TEST SETUP

The EUT is a stand-alone unit during the tests.
 The EUT operation was controlled by connecting with PC using JIG.
 After inputting the command, the JIG and PC was removed during the test.

SETUP DIAGRAM FOR TESTS (CONDUCTED TEST SETUP)

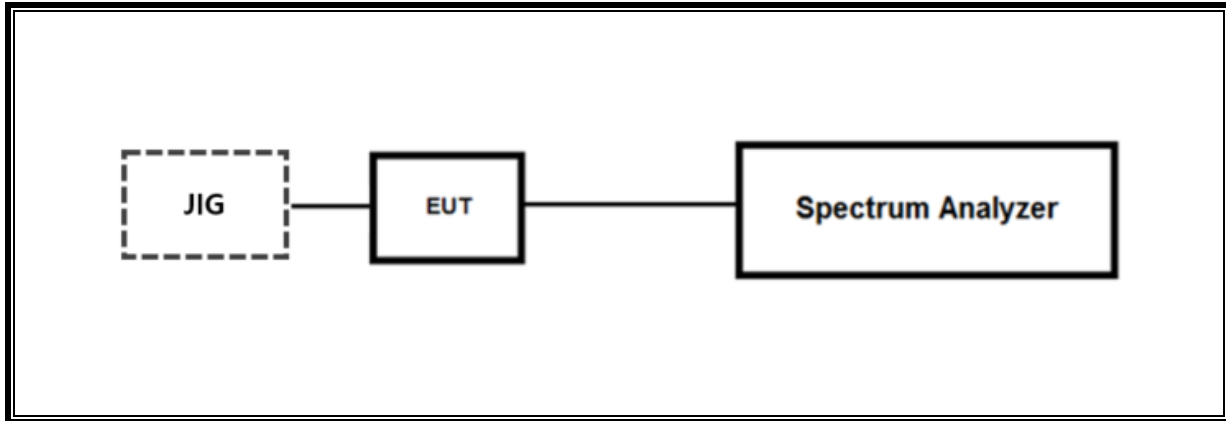

SETUP DIAGRAM FOR TESTS (RADIATED TEST SETUP)

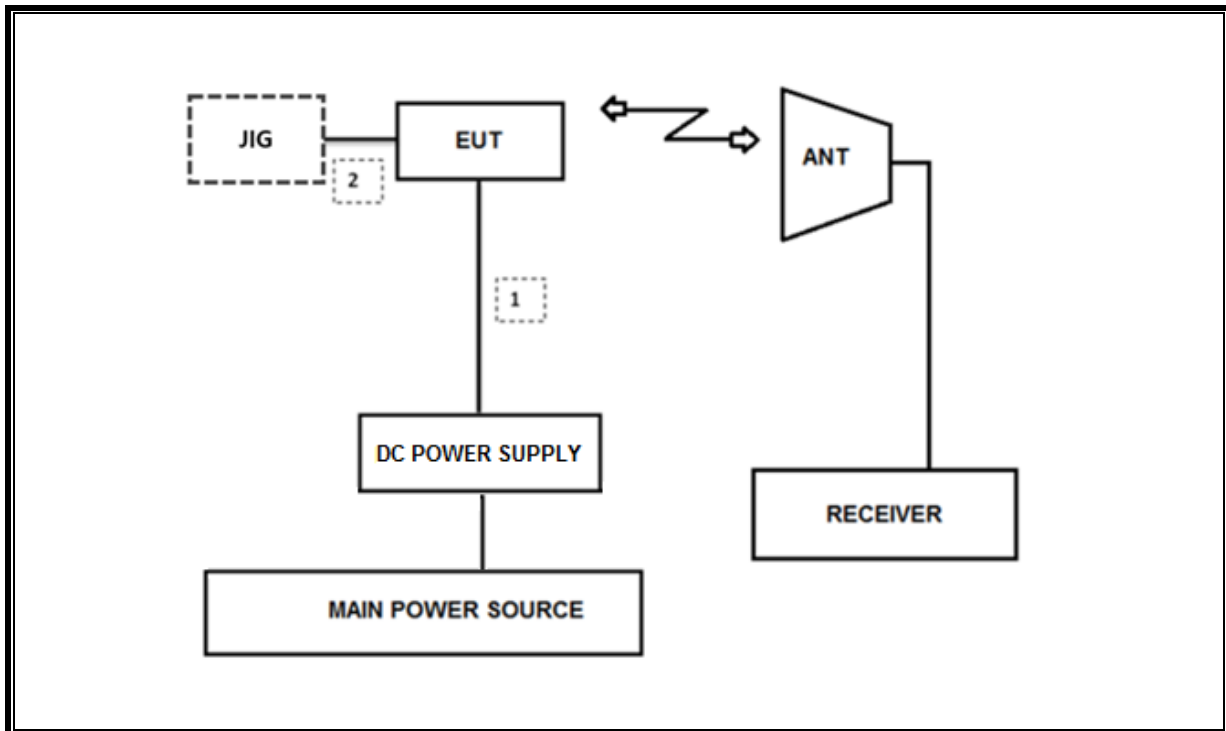

6. TEST AND MEASUREMENT EQUIPMENT

The following test and measurement equipment was utilized for the tests documented in this report:

Test Equipment List				
Description	Manufacturer	Model	S/N	Cal Due
Antenna, Bilog, 30MHz-1GHz	SCHWARZBECK	VULB9163	750	08-04-20
Antenna, Bilog, 30MHz-1GHz	SCHWARZBECK	VULB9163	749	08-04-20
Antenna, Bilog, 30MHz-1GHz	SCHWARZBECK	VULB9163	845	08-04-20
Antenna, Horn, 18 GHz	ETS	3115	00167211	08-04-20
Antenna, Horn, 18 GHz	ETS	3115	00161451	08-04-20
Antenna, Horn, 18 GHz	ETS	3117	00168724	08-04-20
Antenna, Horn, 18 GHz	ETS	3117	00168717	08-04-20
Antenna, Horn, 18 GHz	ETS	3117	00205959	08-04-20
Antenna, Horn, 40 GHz	ETS	3116C	00166155	12-04-19
Antenna, Horn, 40 GHz	ETS	3116C	00168645	08-09-19
Antenna, Horn, 40 GHz	ETS	3116C-PA	00168841	08-07-19
Preamplifier, 1000 MHz	Sonoma	310N	341282	08-07-19
Preamplifier, 1000 MHz	Sonoma	310N	351741	08-06-19
Preamplifier, 1000 MHz	Sonoma	310N	370599	08-07-19
Preamplifier, 18 GHz	Miteq	AFS42-00101800-25-S-42	1876511	08-07-19
Preamplifier, 18 GHz	Miteq	AFS42-00101800-25-S-42	1896138	08-07-19
Preamplifier, 18 GHz	Miteq	AFS42-00101800-25-S-42	2029169	08-07-19
Spectrum Analyzer, 44 GHz	Agilent / HP	N9030A	MY54170614	08-06-19
Spectrum Analyzer, 44 GHz	Agilent / HP	N9030A	MY54490312	08-06-19
Average Power Sensor	Agilent / HP	U2000	MY54270007	08-07-19
Attenuator	PASTERNAK	PE7087-10	A001	08-08-19
Attenuator	PASTERNAK	PE7087-10	A008	08-08-19
Attenuator	PASTERNAK	PE7087-10	2	08-07-19
EMI Test Receive, 40 GHz	R&S	ESU40	100439	08-06-19
EMI Test Receive, 40 GHz	R&S	ESU40	100457	08-06-19
EMI Test Receive, 44 GHz	R&S	ESW44	101590	08-06-19
EMI Test Receive, 3 GHz	R&S	ESR3	101832	08-06-19
Low Pass Filter 5GHz	Micro-Tronics	LPS17541	009	08-07-19
Low Pass Filter 5GHz	Micro-Tronics	LPS17541	015	08-07-19
Low Pass Filter 5GHz	Micro-Tronics	LPS17541	020	08-06-19
High Pass Filter 3GHz	Micro-Tronics	HPM17543	010	08-07-19
High Pass Filter 3GHz	Micro-Tronics	HPM17543	015	08-07-19
High Pass Filter 3GHz	Micro-Tronics	HPM17543	020	08-06-19
High Pass Filter 6GHz	Micro-Tronics	HPS17542	009	08-07-19
High Pass Filter 6GHz	Micro-Tronics	HPS17542	016	08-07-19
High Pass Filter 6GHz	Micro-Tronics	HPS17542	021	08-06-19
Antenna, Loop, 9kHz-30MHz	R&S	HFH2-Z2	100418	10-26-19
LISN	R&S	ENV-216	101837	08-09-19
UL Software				
Description	Manufacturer	Model	Version	
Radiated software	UL	UL EMC	Ver 9.5	
AC Line Conducted software	UL	UL EMC	Ver 9.5	

7. REFERENCE MEASUREMENT RESULTS

7.1. ON TIME AND DUTY CYCLE RESULTS

LIMITS

None: for reporting purposes only.

Mode	ON Time B [msec]	Period [msec]	Duty Cycle x [linear]	Duty Cycle [%]	Duty Cycle Correction Factor [dB]	1/T Minimum VBW [kHz]
2400MHz Bands						
BLE 1M	0.386	0.624	0.619	61.9%	2.08	2.589



7.2. 99% BANDWIDTH

LIMITS

None; for reporting purposes only.

TEST PROCEDURE

The transmitter output is connected to the spectrum analyzer. The RBW is set to 1% to 3% of the 99 % bandwidth and to 1% of the span. The VBW is set to ≥ 3 times the RBW. The spectrum analyzer internal 99% bandwidth function is utilized.

RESULTS

- 1Mbps

Channel	Frequency [MHz]	99% Bandwidth [MHz]
Low	2402	1.078
Mid	2440	1.081
High	2480	1.083
Worst		1.083

99% BANDWIDTH PLOTS

- 1Mbps

<p>Low CH</p>	<p>KeySight Spectrum Analyzer - Occupied BW Center Freq: 2.402000000 GHz Trig: Free Run #Gain: Low #Res BW 30 kHz VBW 300 kHz Span 3 MHz #Sweep 100 ms</p> <table border="1"> <tr> <td>Occupied Bandwidth</td> <td>Total Power</td> <td>3.68 dBm</td> </tr> <tr> <td>1.0779 MHz</td> <td></td> <td></td> </tr> <tr> <td>Transmit Freq Error</td> <td>OBW Power</td> <td>99.00 %</td> </tr> <tr> <td>-7.927 kHz</td> <td>x dB</td> <td>-6.00 dB</td> </tr> <tr> <td>x dB Bandwidth</td> <td></td> <td></td> </tr> <tr> <td>653.4 kHz</td> <td></td> <td></td> </tr> </table>	Occupied Bandwidth	Total Power	3.68 dBm	1.0779 MHz			Transmit Freq Error	OBW Power	99.00 %	-7.927 kHz	x dB	-6.00 dB	x dB Bandwidth			653.4 kHz		
Occupied Bandwidth	Total Power	3.68 dBm																	
1.0779 MHz																			
Transmit Freq Error	OBW Power	99.00 %																	
-7.927 kHz	x dB	-6.00 dB																	
x dB Bandwidth																			
653.4 kHz																			
<p>Middle CH</p>	<p>KeySight Spectrum Analyzer - Occupied BW Center Freq: 2.440000000 GHz Trig: Free Run #Gain: Low #Res BW 30 kHz VBW 300 kHz Span 3 MHz #Sweep 100 ms</p> <table border="1"> <tr> <td>Occupied Bandwidth</td> <td>Total Power</td> <td>3.41 dBm</td> </tr> <tr> <td>1.0813 MHz</td> <td></td> <td></td> </tr> <tr> <td>Transmit Freq Error</td> <td>OBW Power</td> <td>99.00 %</td> </tr> <tr> <td>-8.129 kHz</td> <td>x dB</td> <td>-6.00 dB</td> </tr> <tr> <td>x dB Bandwidth</td> <td></td> <td></td> </tr> <tr> <td>672.0 kHz</td> <td></td> <td></td> </tr> </table>	Occupied Bandwidth	Total Power	3.41 dBm	1.0813 MHz			Transmit Freq Error	OBW Power	99.00 %	-8.129 kHz	x dB	-6.00 dB	x dB Bandwidth			672.0 kHz		
Occupied Bandwidth	Total Power	3.41 dBm																	
1.0813 MHz																			
Transmit Freq Error	OBW Power	99.00 %																	
-8.129 kHz	x dB	-6.00 dB																	
x dB Bandwidth																			
672.0 kHz																			
<p>High CH</p>	<p>KeySight Spectrum Analyzer - Occupied BW Center Freq: 2.480000000 GHz Trig: Free Run #Gain: Low #Res BW 30 kHz VBW 300 kHz Span 3 MHz #Sweep 100 ms</p> <table border="1"> <tr> <td>Occupied Bandwidth</td> <td>Total Power</td> <td>2.89 dBm</td> </tr> <tr> <td>1.0825 MHz</td> <td></td> <td></td> </tr> <tr> <td>Transmit Freq Error</td> <td>OBW Power</td> <td>99.00 %</td> </tr> <tr> <td>-13.371 kHz</td> <td>x dB</td> <td>-6.00 dB</td> </tr> <tr> <td>x dB Bandwidth</td> <td></td> <td></td> </tr> <tr> <td>653.3 kHz</td> <td></td> <td></td> </tr> </table>	Occupied Bandwidth	Total Power	2.89 dBm	1.0825 MHz			Transmit Freq Error	OBW Power	99.00 %	-13.371 kHz	x dB	-6.00 dB	x dB Bandwidth			653.3 kHz		
Occupied Bandwidth	Total Power	2.89 dBm																	
1.0825 MHz																			
Transmit Freq Error	OBW Power	99.00 %																	
-13.371 kHz	x dB	-6.00 dB																	
x dB Bandwidth																			
653.3 kHz																			

8. MEASUREMENT METHODS

6 dB BW : KDB 558074 D01 v05r02, Section 8.2.

OUTPUT POWER : KDB 558074 D01 v05r02, Section 8.3.1.1

POWER SPECTRAL DENSITY : KDB 558074 D01 v05r02, Section 8.4.

Out-of-band Emissions (Conducted) : KDB 558074 D01 v05r02, Section 8.5.

Out-of-band Emissions in Non-restricted Bands: KDB 558074 D01 v05r02, Section 8.5.

Out-of-band Emissions in Restricted Bands : KDB 558074 D01 v05r02, Section 8.6.

AC Power Line Conducted Emission : ANSI C63.10-2013, Section 6.2

9. SUMMARY TABLE

FCC Part Section	IC Section	Test Description	Test Limit	Test Condition	Test Result
15.247 (a)(2)	RSS-247 5.2(a)	Occupied Band width (6dB)	>500KHz	Conducted	Pass
2.1051, 15.247 (d)	RSS-247 5.5	Band Edge / Conducted Spurious Emission	-20dBc		Pass
15.247 (b)(3)	RSS-247 5.4(d)	TX conducted output power	<30dBm		Pass
15.247 (e)	RSS-247 5.2(b)	PSD	<8dBm		Pass
15.207 (a)	RSS-GEN Clause 8.8	AC Power Line conducted emissions	Section 10	Power Line conducted	N/A
15.205, 15.209	RSS-GEN Clause 7 & 8.9	Radiated Spurious Emission	< 54dBuV/m(Av)	Radiated	Pass

10. ANTENNA PORT TEST RESULTS

10.1. 6 dB BANDWIDTH

LIMITS

FCC §15.247 (a) (2) / IC RSS-247 §5.2 (a)

The minimum 6 dB bandwidth shall be at least 500 kHz.

TEST PROCEDURE

Reference to section 11.8 in ANSI C63.10(2013): The transmitter output is connected to a spectrum analyzer with the RBW set to 100kHz, the VBW $\geq 3 \times$ RBW, peak detector and max hold.

RESULTS

- 1Mbps

Channel	Frequency [MHz]	6 dB Bandwidth [kHz]	Minimum Limit [kHz]
Low	2402	750.47	500.0
Mid	2440	756.10	500.0
High	2480	754.96	500.0
Worst		750.47	500.0

6 dB BANDWIDTH PLOTS

- 1Mbps

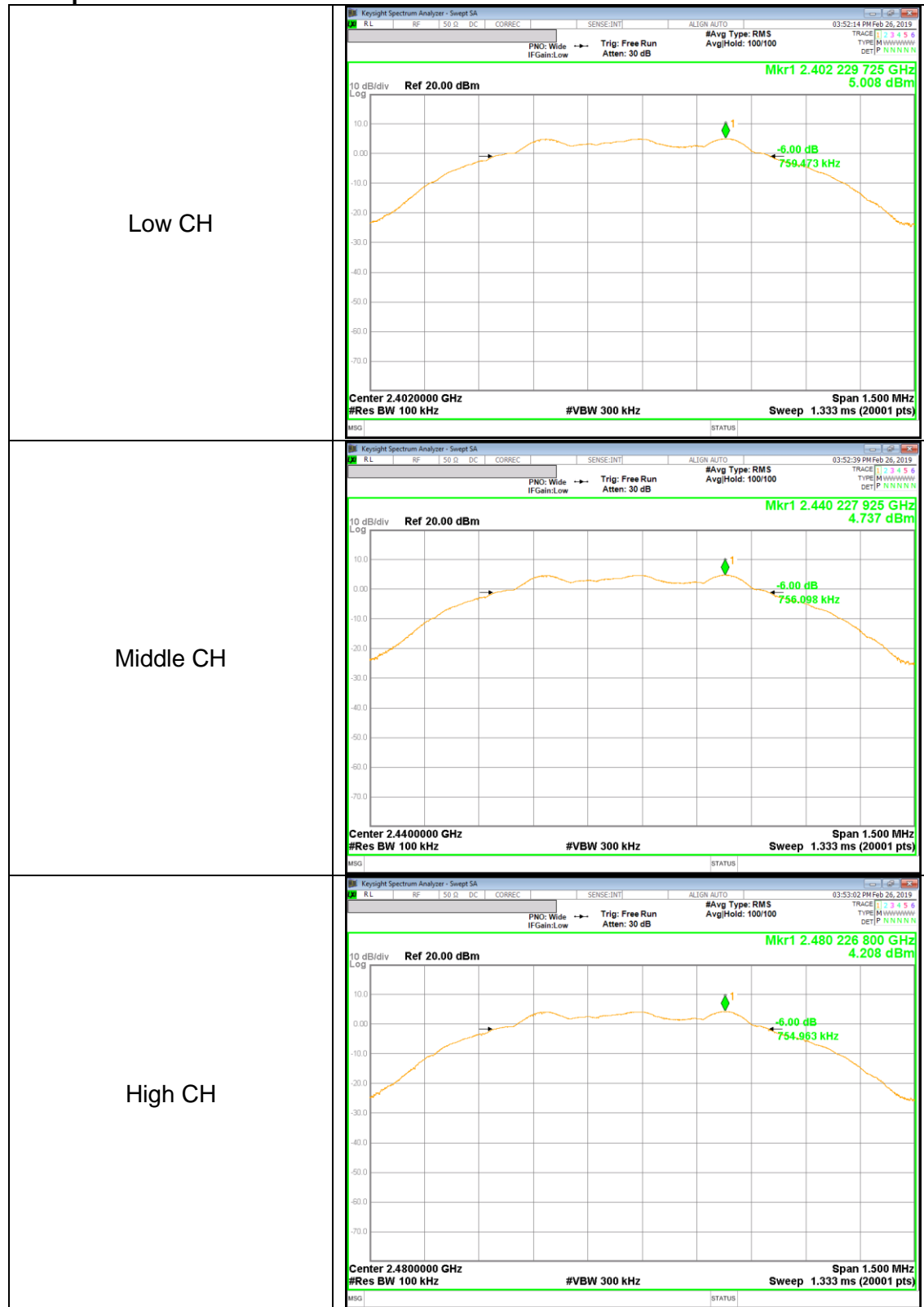

10.2. OUTPUT POWER

LIMITS

FCC §15.247 (b) / IC RSS-247 §5.4 (d)

The maximum antenna gain is less than or equal to 6 dBi, therefore the limit is 30 dBm.

TEST PROCEDURE

Peak power is measured using ANSI C63.10(2013) under section 11.9.1.1 utilizing spectrum analyzer.

RESULTS

- 1Mbps

Channel	Frequency [MHz]	Peak Power Reading [dBm]	Limit [dBm]	Margin [dB]
Low	2402	5.831	30.000	-24.169
Mid	2440	5.568	30.000	-24.432
High	2480	5.042	30.000	-24.958
Worst		5.831	30.000	-24.169

OUTPUT POWER PLOTS

- 1Mbps

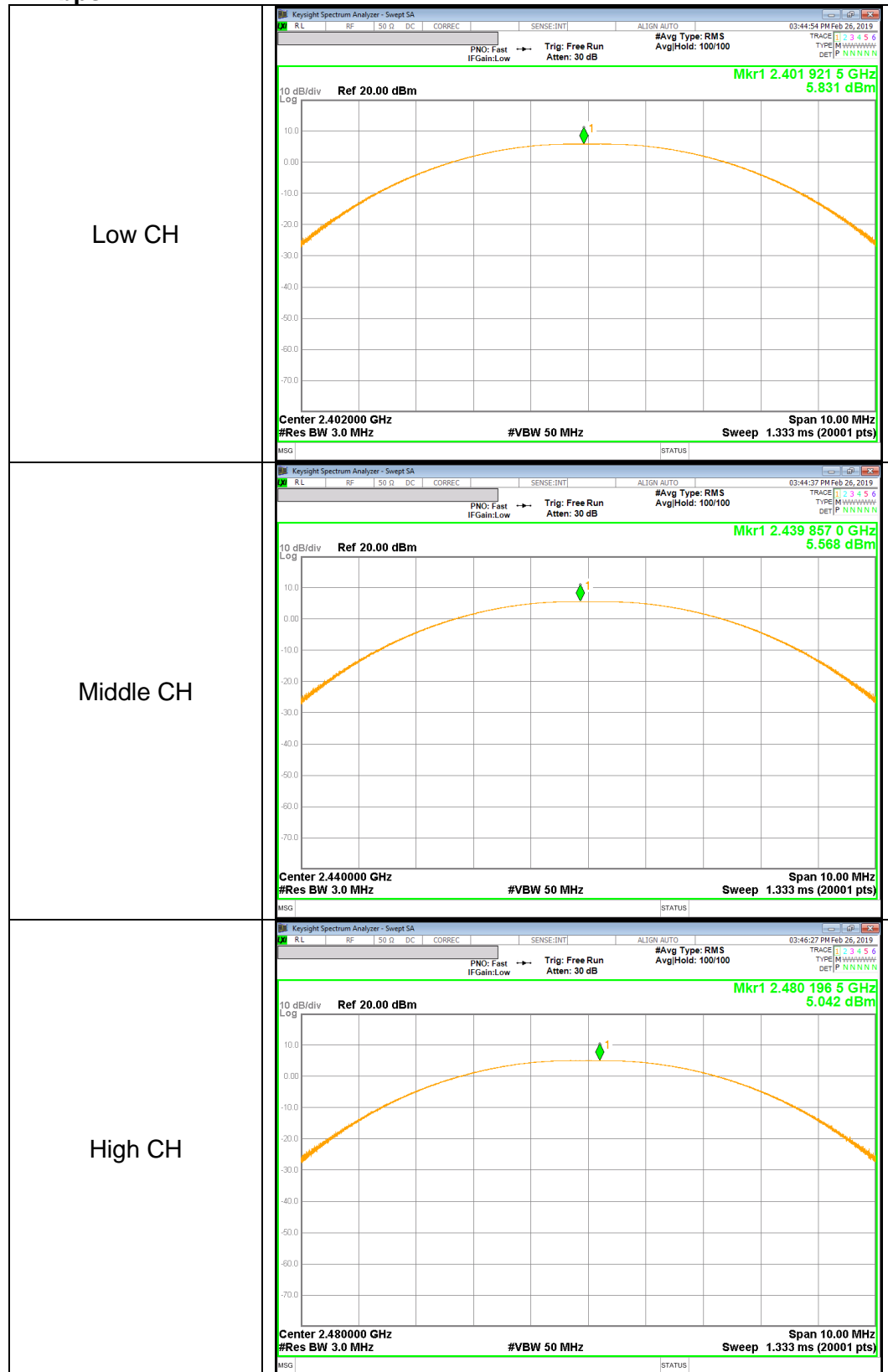

10.3. AVERAGE POWER

LIMITS

None; for reporting purposes only.

TEST PROCEDURE

The transmitter output is connected to a power meter.

RESULTS

The cable assembly insertion loss was entered as an offset in the power meter to allow for direct reading of power. The duty factor already has been added.

- 1Mbps

Channel	Frequency [MHz]	AV power [dBm]	AV power [mW]
Low	2402	5.572	3.607
Middle	2440	5.304	3.391
High	2480	4.785	3.009

10.4. PSD

LIMITS

FCC §15.247 / IC RSS-247 §5.2 (b)

The power spectral density conducted from the transmitter to the antenna shall not be greater than 8 dBm in any 3 kHz band during any time interval of continuous transmission.

TEST PROCEDURE

Power Spectral Density was performed utilizing the ANSI C63.10 section 11.10.2 (Method PKPSD).

RESULTS

- 1Mbps

Channel	Frequency [MHz]	PSD [dBm/3kHz]	Limit [dBm/3kHz]	Margin [dB]
Low	2402	-9.98	8.00	-17.98
Mid	2440	-10.27	8.00	-18.27
High	2480	-10.78	8.00	-18.78

POWER SPECTRAL DENSITY PLOTS

- 1Mbps

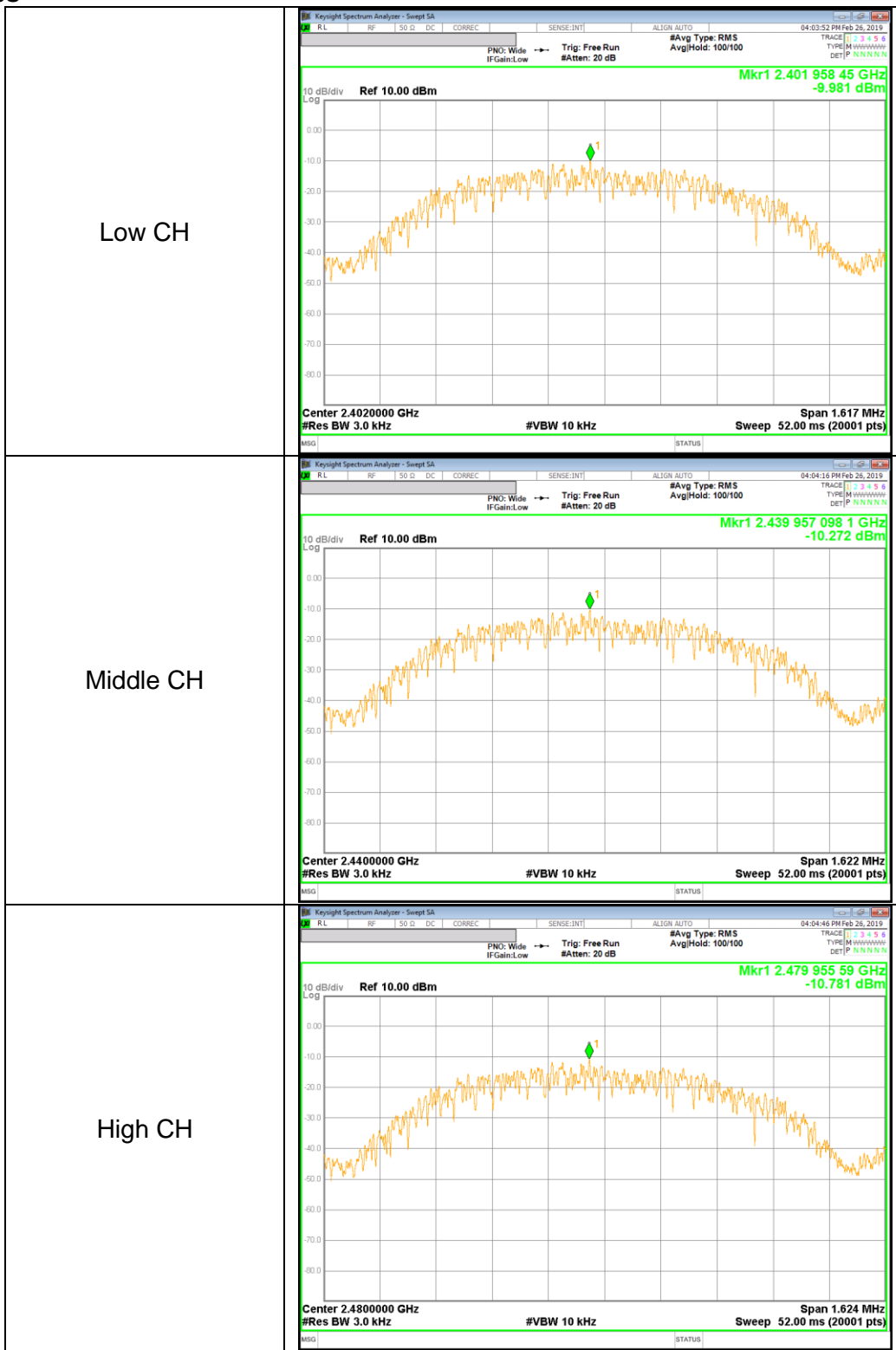

10.5. OUT-OF-BAND EMISSIONS

LIMITS

FCC §15.247 (d) / IC RSS-247 §5.5

In any 100 kHz bandwidth outside the frequency band in which the spread spectrum or digitally modulated intentional radiator is operating, the radio frequency power that is produced by the intentional radiator shall be at least 20 dB below that in the 100 kHz bandwidth within the band that contains the highest level of the desired power, based on either an RF conducted or a radiated measurement, provided the transmitter demonstrates compliance with the peak conducted power limits. If the transmitter complies with the conducted power limits based on the use of RMS averaging over a time interval, as permitted under paragraph (b)(3) of this section, the attenuation required under this paragraph shall be 30 dB instead of 20 dB. Attenuation below the general limits specified in §15.209(a) is not required.

TEST PROCEDURE

The transmitter output is connected to a spectrum analyzer with RBW = 100 kHz, VBW = 300 kHz, peak detector, and max hold. Measurements utilizing these settings are made of the in-band reference level, bandedge (where measurements to the general radiated limits will not be made) and out-of-band emissions.

RESULTS

BANDEDGE & SPURIOUS EMISSIONS, LOW CHANNEL (1Mbps)

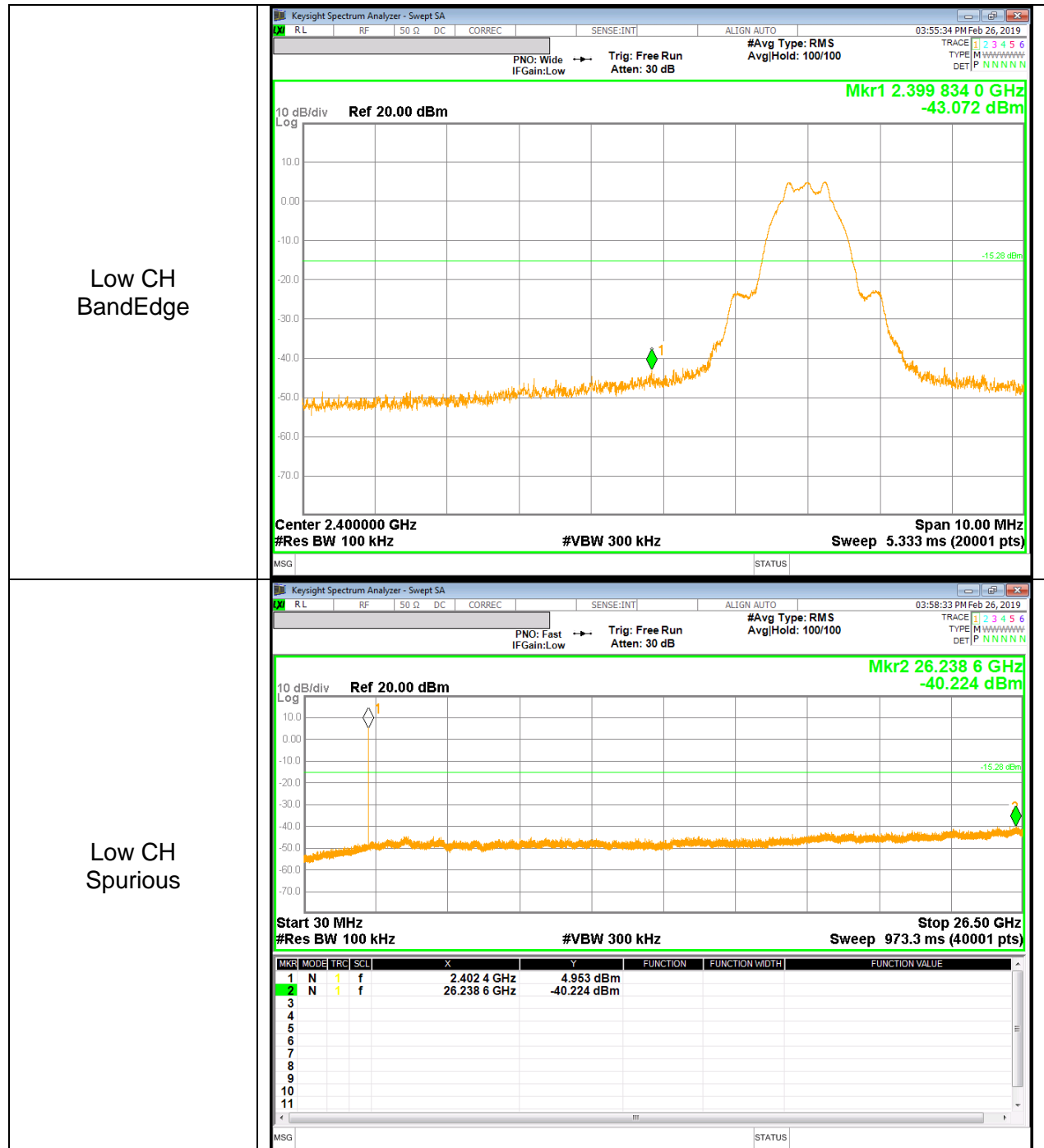

SPURIOUS EMISSIONS, MID CHANNEL (1Mbps)

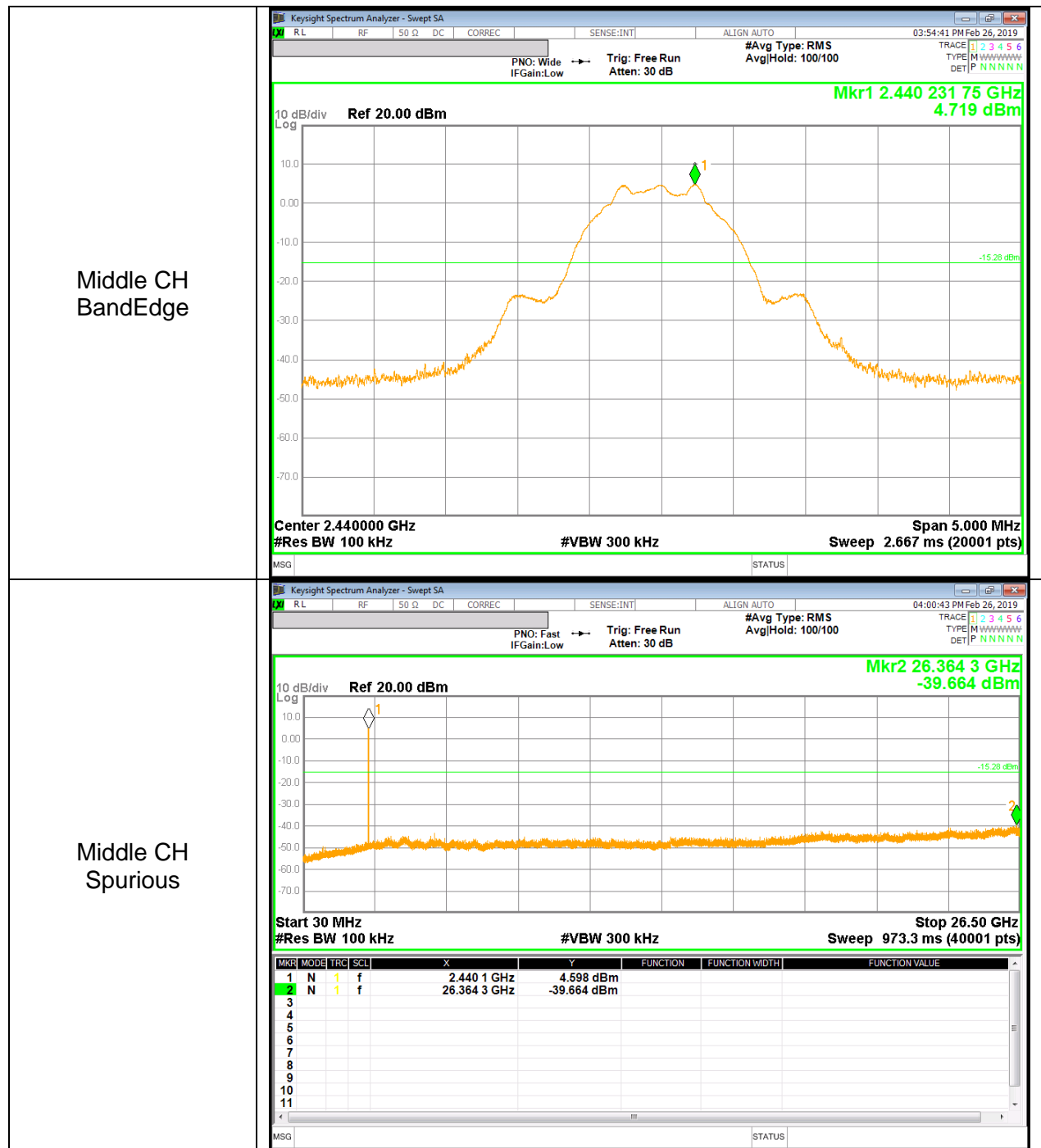

SPURIOUS EMISSIONS, HIGH CHANNEL (1Mbps)

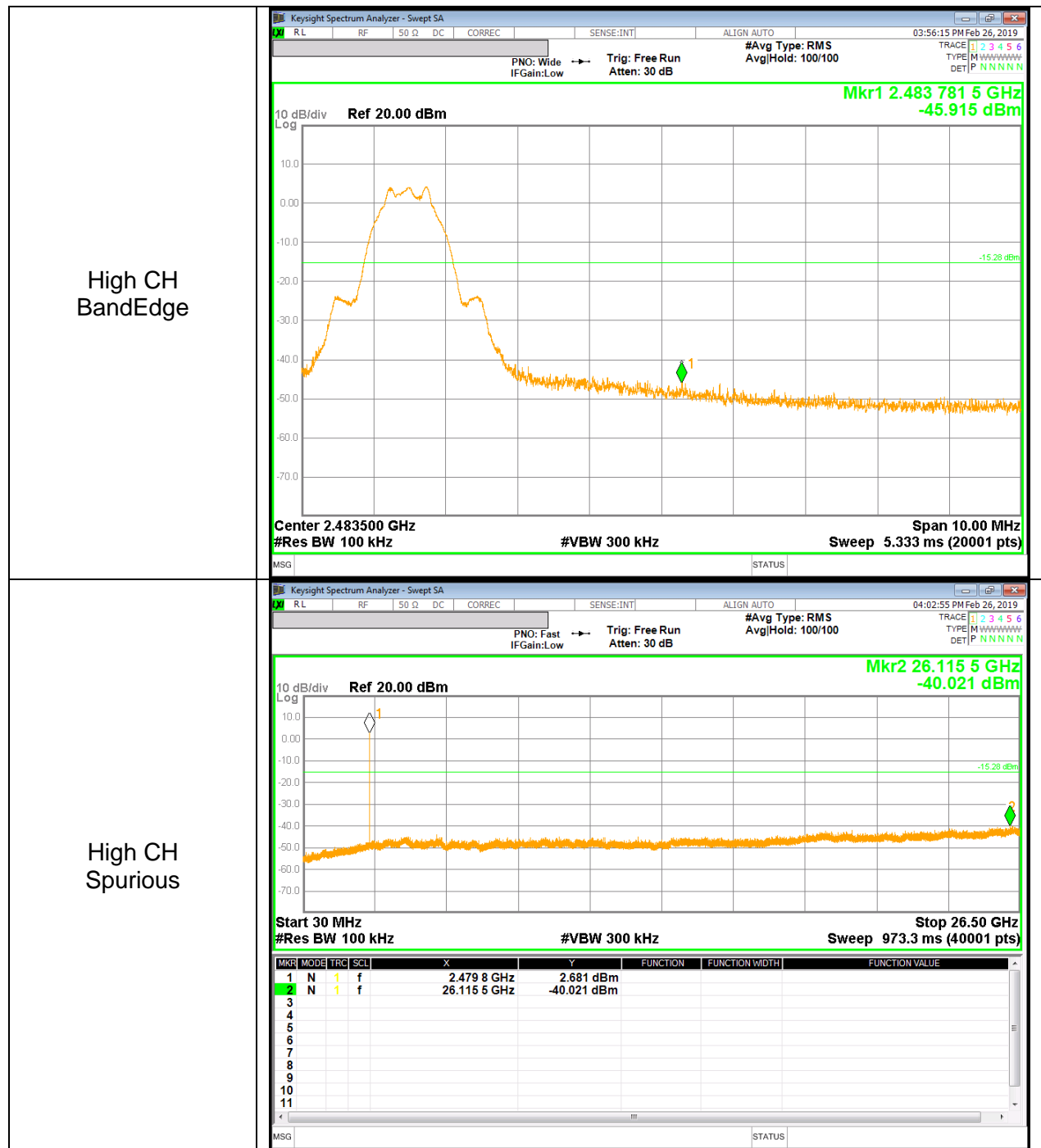

11. RADIATED TEST RESULTS

11.1. LIMITS AND PROCEDURE

LIMITS

FCC §15.205 and §15.209
IC RSS-GEN Clause 8.9 (Transmitter)
IC RSS-GEN Clause 7 (Receiver)
IC RSS-GEN Clause 8.10

Limits for radiated disturbance of an intentional radiator		
Frequency range (MHz)	Limits ($\mu\text{V}/\text{m}$)	Measurement Distance (m)
0.009 – 0.490	2400 / F (kHz)	300
0.490 – 1.705	24000 / F (kHz)	30
1.705 – 30.0	30	30
30 – 88	100**	3
88 - 216	150**	3
216 – 960	200**	3
Above 960	500	3

** Except as provided in paragraph (g), fundamental emissions from intentional radiators operating under this section shall not be located in the frequency bands 54-72 MHz, 76-88 MHz, 174-216 MHz or 470-806 MHz. However, operation within these frequency bands is permitted under other sections of this part, e.g. §§ 15.231 and 15.241.

TEST PROCEDURE

The EUT is placed on a non-conducting table 80 cm above the ground plane for below 1GHz and 150 cm for above 1GHz. The antenna to EUT distance is 3 meters. The EUT is configured in accordance with ANSI C63.10. The EUT is set to transmit in a continuous mode.

For measurements below 1 GHz the resolution bandwidth is set to 100 kHz for peak detection measurements or 120 kHz for quasi-peak detection measurements. Peak detection is used unless otherwise noted as quasi-peak.

For measurements above 1 GHz the resolution bandwidth is set to 1 MHz, then the video bandwidth is set to 3 MHz for peak measurements and add duty cycle factor for average measurements. (Restricted bandedge, Final detection of spurious harmonic emissions) Duty cycle factor = $10 \log(1/x)$. For this sample: DCF = $10 \log(1/0.619) = 2.08$ dB (Spectrum Analyzer round it up to 2.08dB).

Pre-scans to detect harmonic and spurious emissions, the resolution bandwidth is set to 1 MHz; the video bandwidth is set to 30 KHz for peak measurements.

The spectrum from 1 GHz to 26 GHz is investigated with the transmitter set to the lowest, middle, and highest channels in the 2.4 GHz band.
(From 30MHz to 1GHz, test was performed with the EUT set to transmit at the channel with highest output power)

The frequency range of interest is monitored at a fixed antenna height and EUT azimuth. The EUT is rotated through 360 degrees to maximize emissions received. The antenna is scanned from 1 to 4 meters above the ground plane to further maximize the emission. Measurements are made with the antenna polarized in both the vertical and the horizontal positions.

Note : Emission was pre-scanned from 9KHz to 30MHz; No emissions were detected which was at least 20dB below the specification limit (consider distance correction factor).
Per FCC part 15.31(o), test results were not reported.

Although these tests were performed other than open field test site, adequate comparison measurements were confirmed against 30 m open are test site.
Therefore sufficient tests were made to demonstrate that the alternative site produces results that correlate with the one of tests made in an open field based on KDB 414788.

11.2. TRANSMITTER ABOVE 1 GHz

11.2.1. 1Mbps MODE

RESTRICTED BANDEDGE (LOW CHANNEL)

HORIZONTAL PEAK AND AVERAGE DATA

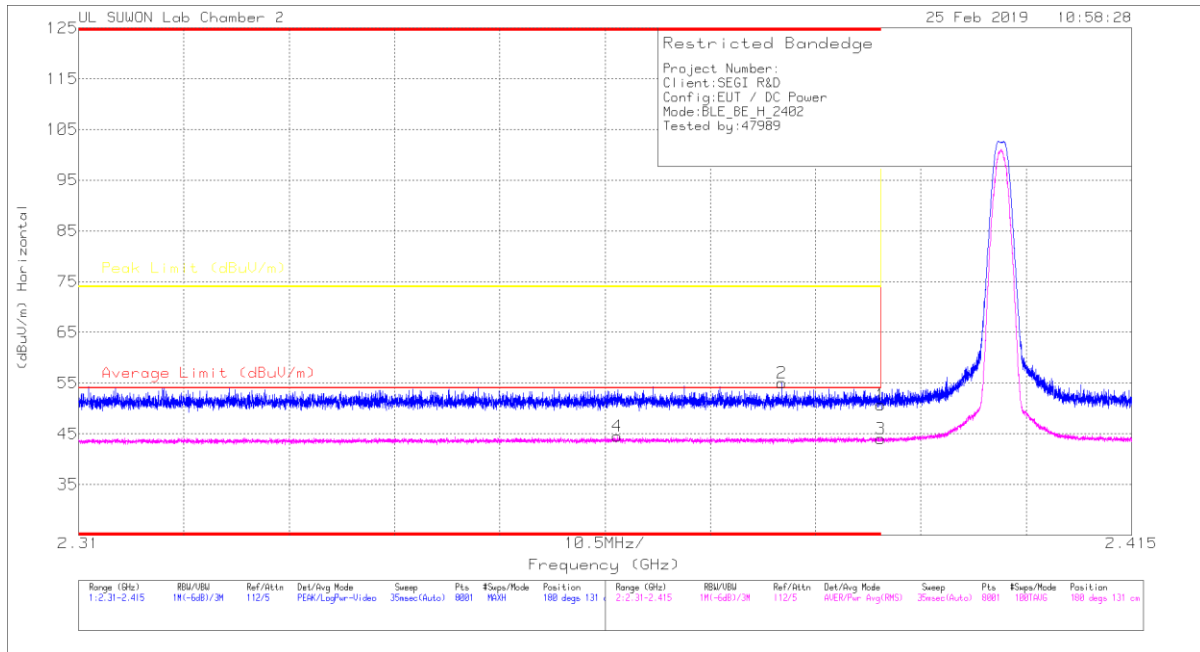

Trace Markers

Marker	Frequency (GHz)	Meter Reading (dBuV)	Det	3117_00168724	10dB(dB)	DC Corr (dB)	Corrected Reading (dBuV/m)	Average Limit (dBuV/m)	Margin (dB)	Peak Limit (dBuV/m)	PK Margin (dB)	Azimuth (Degs)	Height (cm)	Polarity
1	* 2.39	39.85	Pk	31.6	-20.8	0	50.65	-	-	74	-23.35	180	131	H
2	* 2.38	44.27	Pk	31.6	-20.8	0	55.07	-	-	74	-18.93	180	131	H
3	* 2.39	31.19	RMS	31.6	-20.8	2.08	44.07	54	-9.93	-	-	180	131	H
4	* 2.364	31.58	RMS	31.6	-20.8	2.08	44.46	54	-9.54	-	-	180	131	H

* - indicates frequency in CFR47 Pt 15 / IC RSS-Restricted Band

Pk - Peak detector

RMS - RMS detection

VERTICAL PEAK AND AVERAGE PLOT

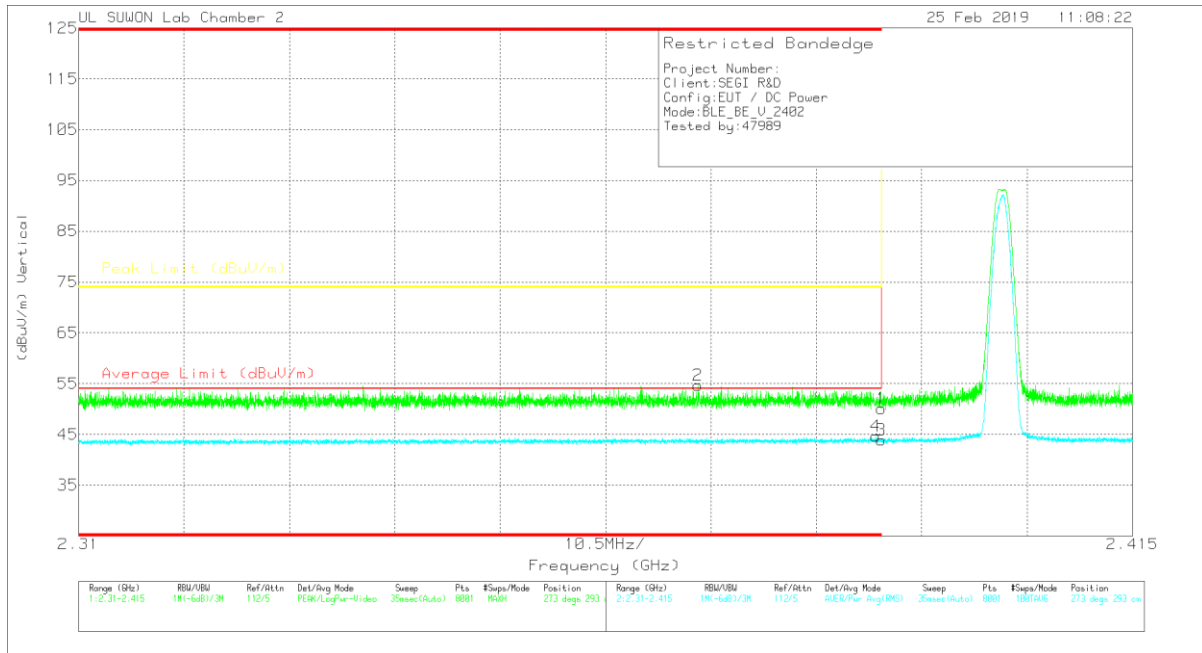

Trace Markers

Marker	Frequency (GHz)	Meter Reading (dBuV)	Det	3117_00168724	10dB(dB)	DC Corr (dB)	Corrected Reading (dBuV/m)	Average Limit (dBuV/m)	Margin (dB)	Peak Limit (dBuV/m)	PK Margin (dB)	Altitude (Degs)	Height (cm)	Polarity
1	* 2.39	39.25	Pk	31.6	-20.8	0	50.05	-	-	74	-23.95	273	293	V
2	* 2.372	43.81	Pk	31.6	-20.8	0	54.61	-	-	74	-19.39	273	293	V
3	* 2.39	31.02	RMS	31.6	-20.8	2.08	43.9	54	-10.1	-	-	273	293	V
4	* 2.389	31.75	RMS	31.6	-20.8	2.08	44.63	54	-9.37	-	-	273	293	V

* - indicates frequency in CFR47 Pt 15 / IC RSS-Restricted Band

Pk - Peak detector

RMS - RMS detection

AUTHORIZED BANDEDGE (HIGH CHANNEL)

HORIZONTAL PEAK AND AVERAGE DATA

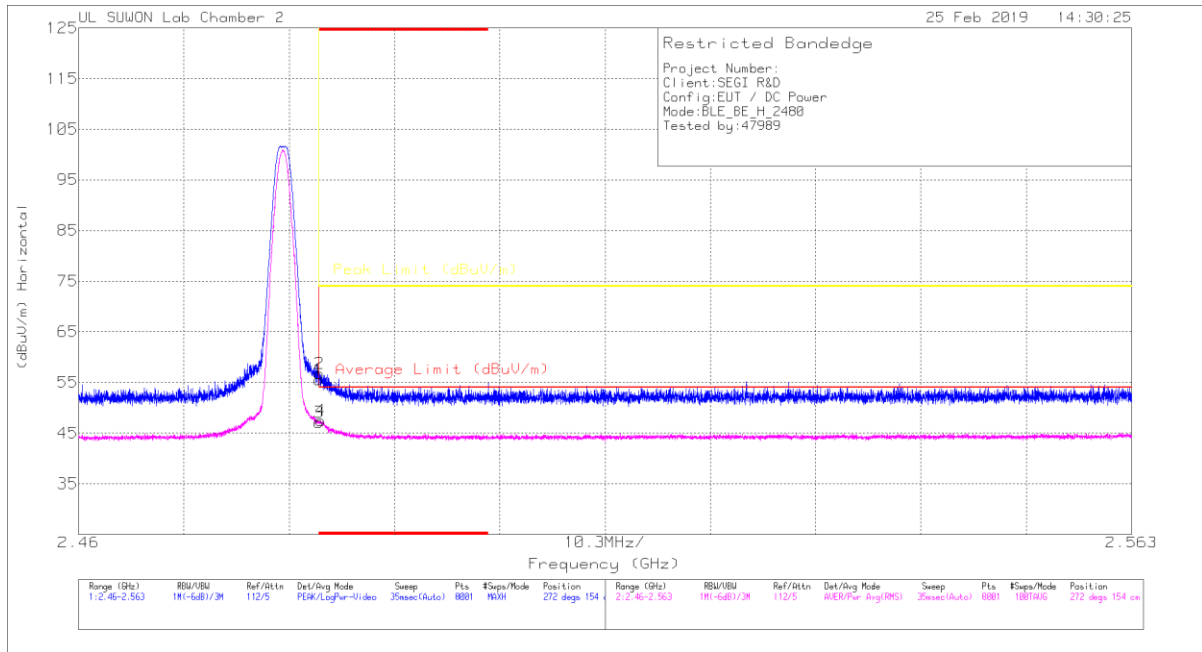

Trace Markers

Marker	Frequency (GHz)	Meter Reading (dBuV)	Det	3117_00168724	10dB(dB)	DC Corr (dB)	Corrected Reading (dBuV/m)	Average Limit (dBuV/m)	Margin (dB)	Peak Limit (dBuV/m)	PK Margin (dB)	Altitude (Degs)	Height (cm)	Polarity
1	* 2.484	44.17	Pk	31.9	-20.6	0	55.47	-	-	74	-18.53	272	154	H
2	* 2.484	45.48	Pk	31.9	-20.6	0	56.78	-	-	74	-17.22	272	154	H
3	* 2.484	33.77	RMS	31.9	-20.6	2.08	47.15	54	-6.85	-	-	272	154	H
4	* 2.484	34.13	RMS	31.9	-20.6	2.08	47.51	54	-6.49	-	-	272	154	H

* - indicates frequency in CFR47 Pt 15 / IC RSS-Restricted Band

Pk - Peak detector

RMS - RMS detection

VERTICAL PEAK AND AVERAGE PLOT

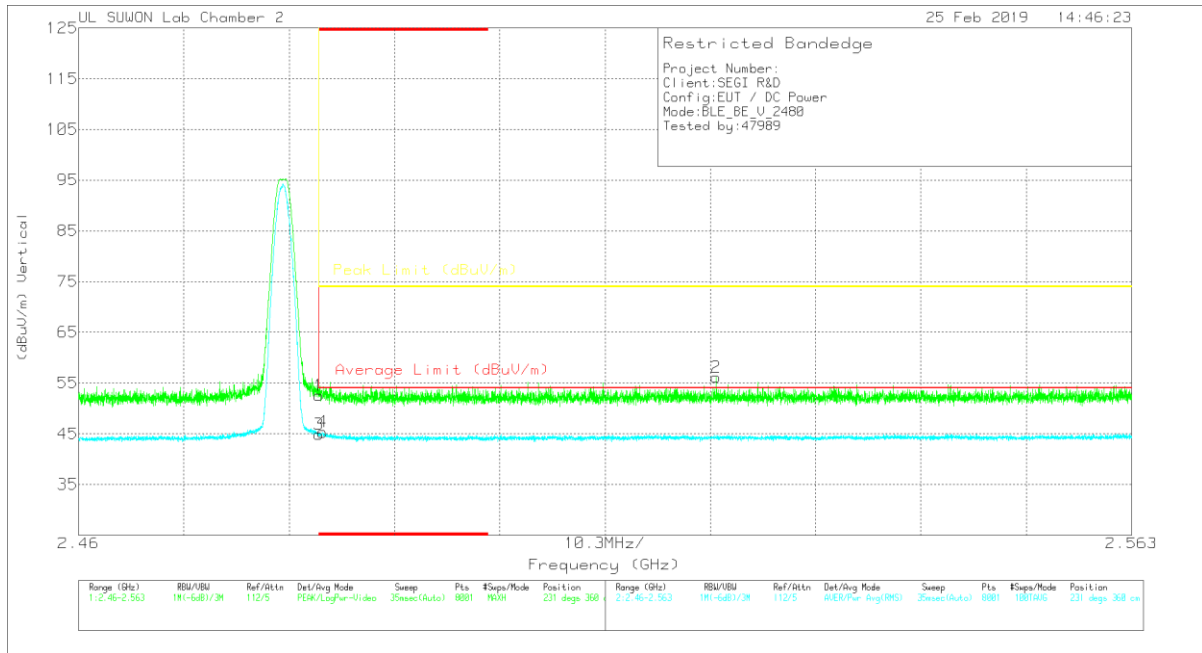

Trace Markers

Marker	Frequency (GHz)	Meter Reading (dBuV)	Det	3117_00168724	10dB(dB)	DC Corr (dB)	Corrected Reading (dBuV/m)	Average Limit (dBuV/m)	Margin (dB)	Peak Limit (dBuV/m)	PK Margin (dB)	Azimuth (Degs)	Height (cm)	Polarity
1	* 2.484	41.26	Pk	31.9	-20.6	0	52.56	-	-	74	-21.44	231	360	V
2	2.522	44.74	Pk	31.9	-20.5	0	56.14	-	-	74	-17.86	231	360	V
3	* 2.484	31.53	RMS	31.9	-20.6	2.08	44.91	54	-9.09	-	-	231	360	V
4	* 2.484	31.94	RMS	31.9	-20.6	2.08	45.32	54	-8.68	-	-	231	360	V

* - indicates frequency in CFR47 Pt 15 / IC RSS-Restricted Band

Pk - Peak detector

RMS - RMS detection

HARMONICS AND SPURIOUS EMISSIONS

LOW CHANNEL HORIZONTAL

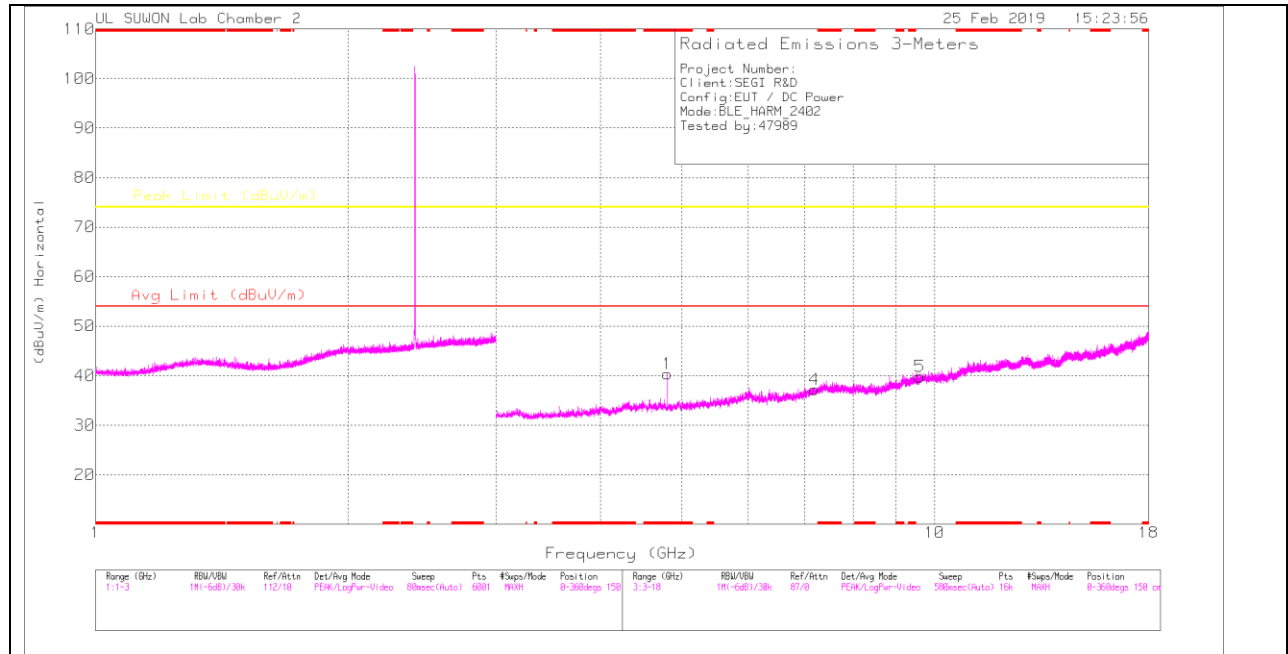

LOW CHANNEL VERTICAL

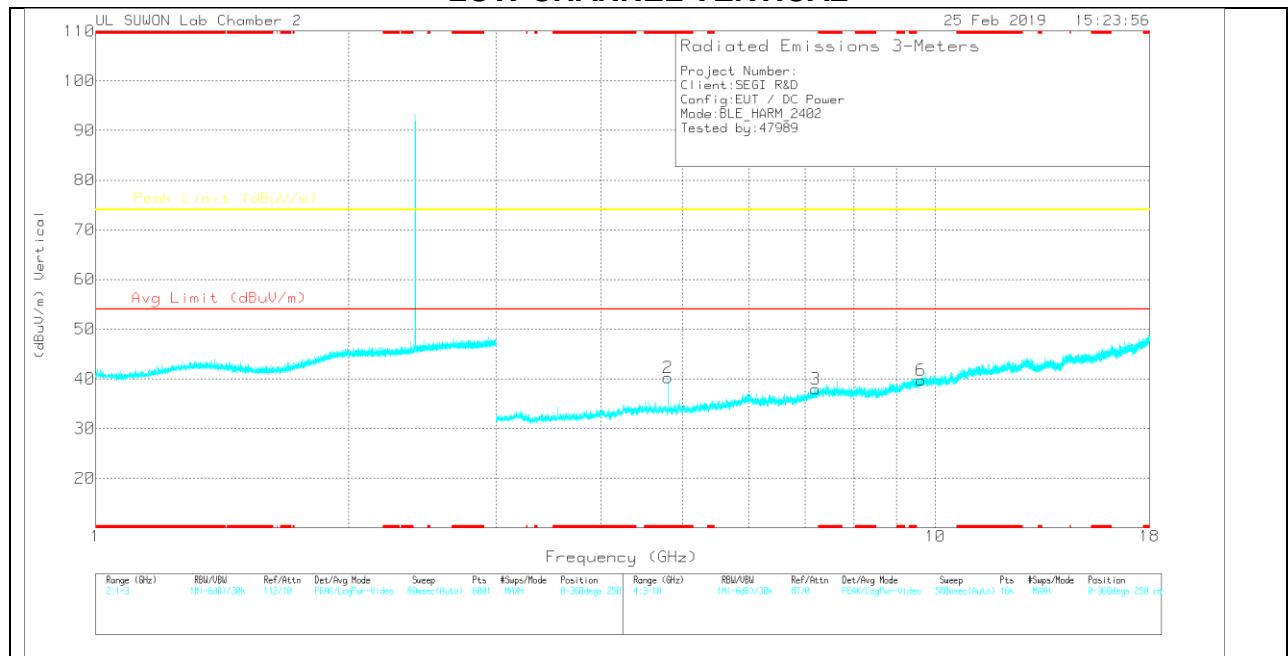

Note: Emission was scanned up to 26GHz; No emissions were detected above the noise floor which was at least 20dB below the specification limit.

LOW CHANNEL DATA

Trace Markers

Marker	Frequency (GHz)	Meter Reading (dBuV)	Det	3117_00168724	3GHz_HP[dB]	DC Corr (dB)	Corrected Reading (dBuV/m)	Avg Limit (dBuV/m)	Margin (dB)	Peak Limit (dBuV/m)	Margin (dB)	Azimuth (Degs)	Height (cm)	Polarity
1	* 4.803	34.32	PK	34	-28	0	40.32	-	-	74	-33.68	0-360	150	H
4	7.198	26.46	PK	36.1	-25.3	0	37.26	-	-	74	-36.74	0-360	150	H
5	9.608	24.7	PK	37	-21.9	0	39.8	-	-	74	-34.2	0-360	150	H
2	* 4.803	34.24	PK	34	-28	0	40.24	-	-	74	-33.76	0-360	250	V
3	7.204	27.12	PK	36.1	-25.3	0	37.92	-	-	74	-36.08	0-360	250	V
6	9.616	24.52	PK	37	-21.8	0	39.72	-	-	74	-34.28	0-360	250	V

* - indicates frequency in CFR47 Pt 15 / IC RSS-Restricted Band
 PK – Peak detector

Radiated Emissions

Frequency (GHz)	Meter Reading (dBuV)	Det	3117_00168724	3GHz_HP[dB]	DC Corr (dB)	Corrected Reading (dBuV/m)	Avg Limit (dBuV/m)	Margin (dB)	Peak Limit (dBuV/m)	Margin (dB)	Azimuth (Degs)	Height (cm)	Polarity
* 4.804	41.35	PK2	34	-28.1	0	47.25	-	-	74	-26.75	341	100	H
* 4.804	32.42	MAv1	34	-28.1	2.08	40.4	54	-13.6	-	-	341	100	H
* 4.805	41.23	PK2	34	-28.1	0	47.13	-	-	74	-26.87	254	214	V
* 4.804	32.24	MAv1	34	-28.1	2.08	40.22	54	-13.78	-	-	254	214	V

* - indicates frequency in CFR47 Pt 15 / IC RSS-Restricted Band
 PK2 - KDB558074 Method: Maximum Peak
 MAv1 - KDB558074 Option 1 Maximum RMS Average

MID CHANNEL HORIZONTAL

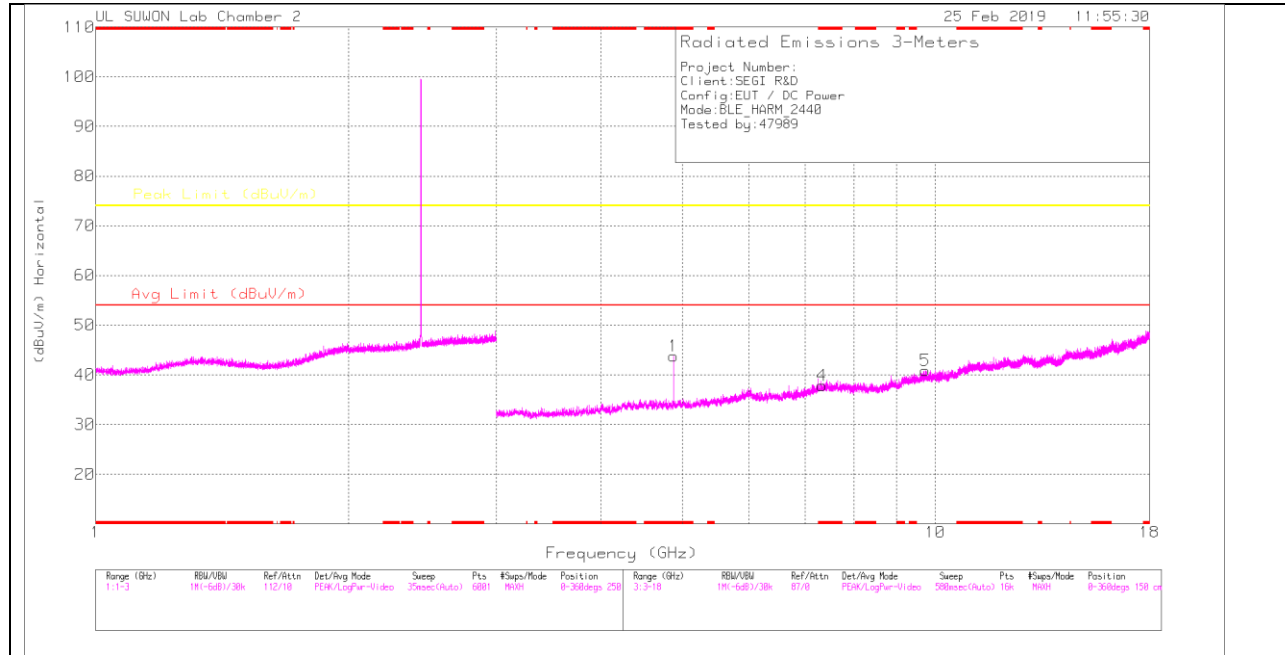

MID CHANNEL VERTICAL

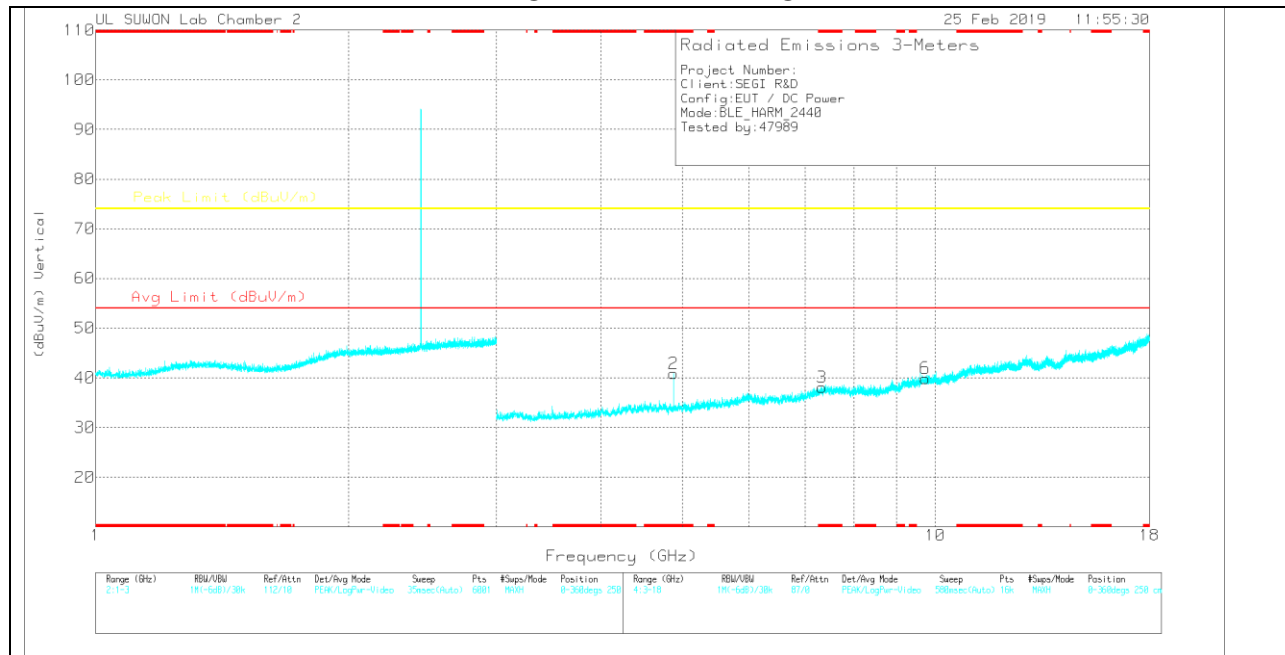

Note: Emission was scanned up to 26GHz; No emissions were detected above the noise floor which was at least 20dB below the specification limit.

MID CHANNEL DATA

Trace Markers

Marker	Frequency (GHz)	Meter Reading (dBuV)	Det	3117_00168724	3GHz_HP[dB]	DC Corr (dB)	Corrected Reading (dBuV/m)	Avg Limit (dBuV/m)	Margin (dB)	Peak Limit (dBuV/m)	Margin (dB)	Azimuth (Degs)	Height (cm)	Polarity
1	* 4.88	37.68	PK	34	-27.9	0	43.78	-	-	74	-30.22	0-360	150	H
4	* 7.326	26.58	PK	36.2	-24.9	0	37.88	-	-	74	-36.12	0-360	250	H
5	9.731	24.92	PK	37.2	-21.3	0	40.82	-	-	74	-33.18	0-360	250	H
2	* 4.88	34.8	PK	34	-27.9	0	40.9	-	-	74	-33.1	0-360	250	V
3	* 7.33	26.63	PK	36.2	-24.8	0	38.03	-	-	74	-35.97	0-360	250	V
6	9.731	24.02	PK	37.2	-21.3	0	39.92	-	-	74	-34.08	0-360	250	V

* - indicates frequency in CFR47 Pt 15 / IC RSS-Restricted Band

PK – Peak detector

Radiated Emissions

Frequency (GHz)	Meter Reading (dBuV)	Det	3117_00168724	3GHz_HP[dB]	DC Corr (dB)	Corrected Reading (dBuV/m)	Avg Limit (dBuV/m)	Margin (dB)	Peak Limit (dBuV/m)	Margin (dB)	Azimuth (Degs)	Height (cm)	Polarity
* 4.88	43.86	PK2	34	-27.9	0	49.96	-	-	74	-24.04	271	104	H
* 4.88	35.76	MAv1	34	-27.9	2.08	43.94	54	-10.06	-	-	271	104	H
* 4.88	42.44	PK2	34	-27.9	0	48.54	-	-	74	-25.46	261	256	V
* 4.88	34.23	MAv1	34	-27.9	2.08	42.41	54	-11.59	-	-	261	256	V

* - indicates frequency in CFR47 Pt 15 / IC RSS-Restricted Band

PK2 - KDB558074 Method: Maximum Peak

MAv1 - KDB558074 Option 1 Maximum RMS Average

HIGH CHANNEL HORIZONTAL

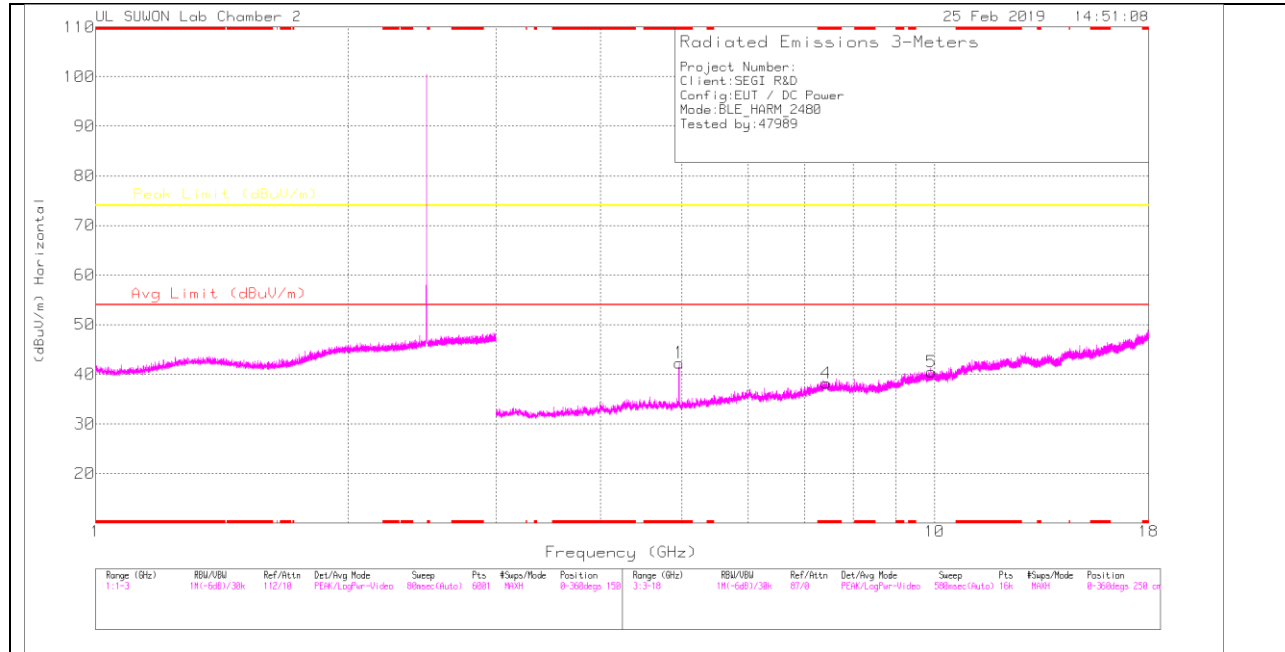

HIGH CHANNEL VERTICAL

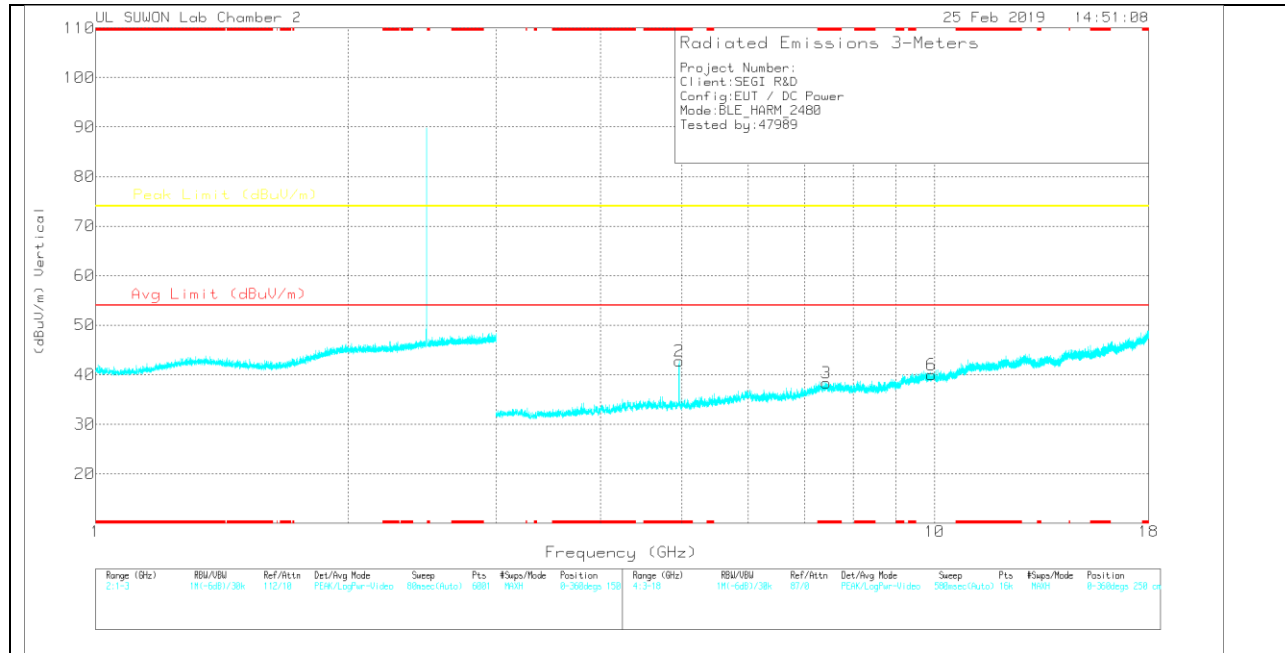

Note: Emission was scanned up to 26GHz; No emissions were detected above the noise floor which was at least 20dB below the specification limit.

HIGH CHANNEL DATA

Trace Markers

Marker	Frequency (GHz)	Meter Reading (dBuV)	Det	3117_00168724	3GHz_HP[dB]	DC Corr (dB)	Corrected Reading (dBuV/m)	Avg Limit (dBuV/m)	Margin (dB)	Peak Limit (dBuV/m)	Margin (dB)	Azimuth (Degs)	Height (cm)	Polarity
1	* 4.96	35.32	PK	34.1	-27.1	0	42.32	-	-	74	-31.68	0-360	250	H
4	* 7.436	26.03	PK	36.2	-24	0	38.23	-	-	74	-35.77	0-360	250	H
5	9.922	23.94	PK	37.4	-20.9	0	40.44	-	-	74	-33.56	0-360	250	H
2	* 4.96	35.76	PK	34.1	-27.1	0	42.76	-	-	74	-31.24	0-360	250	V
3	* 7.436	26.09	PK	36.2	-24	0	38.29	-	-	74	-35.71	0-360	150	V
6	9.916	23.64	PK	37.4	-21.1	0	39.94	-	-	74	-34.06	0-360	150	V

* - indicates frequency in CFR47 Pt 15 / IC RSS-Restricted Band
 PK – Peak detector

Radiated Emissions

Frequency (GHz)	Meter Reading (dBuV)	Det	3117_00168724	3GHz_HP[dB]	DC Corr (dB)	Corrected Reading (dBuV/m)	Avg Limit (dBuV/m)	Margin (dB)	Peak Limit (dBuV/m)	Margin (dB)	Azimuth (Degs)	Height (cm)	Polarity
* 4.961	41.24	PK2	34.1	-27.1	0	48.24	-	-	74	-25.76	205	148	H
* 4.96	32.48	MAv1	34.1	-27.1	2.08	41.56	54	-12.44	-	-	205	148	H
* 4.959	42.35	PK2	34.1	-27.1	0	49.35	-	-	74	-24.65	240	241	V
* 4.96	33.93	MAv1	34.1	-27.1	2.08	43.01	54	-10.99	-	-	240	241	V

* - indicates frequency in CFR47 Pt 15 / IC RSS-Restricted Band
 PK2 - KDB558074 Method: Maximum Peak
 MAv1 - KDB558074 Option 1 Maximum RMS Average

11.3. WORST-CASE BELOW 1 GHz

SPURIOUS EMISSIONS 30 TO 1000 MHz

HORIZONTAL PLOT

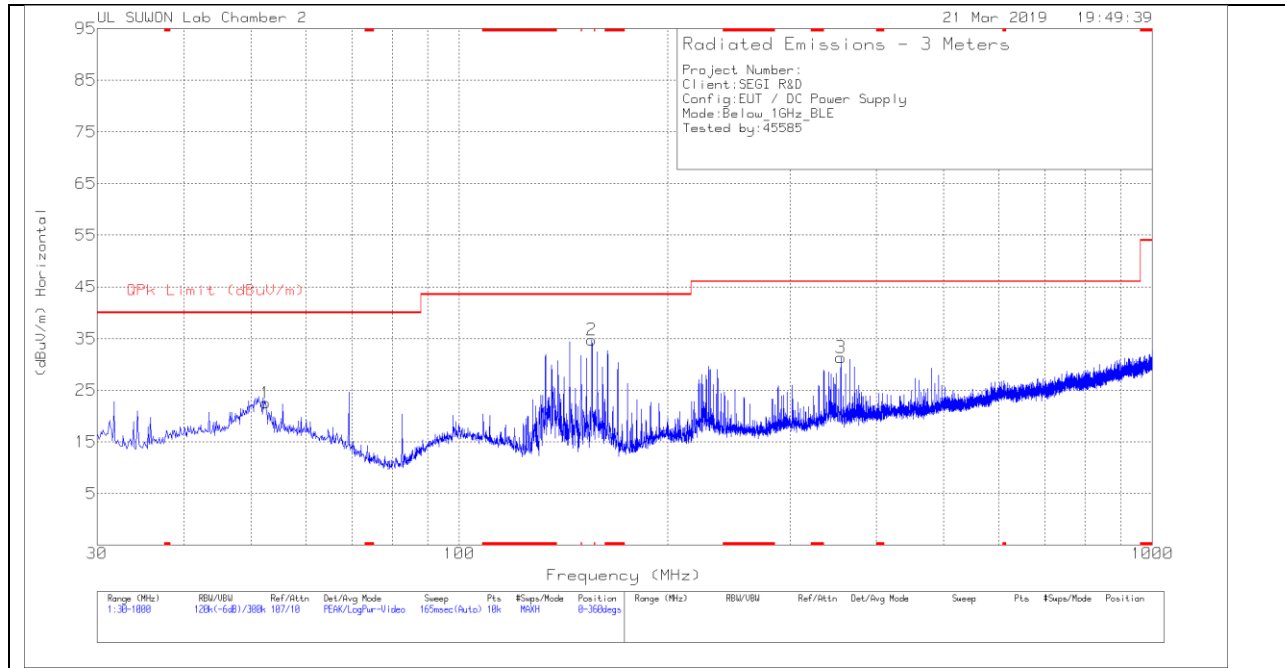

VERTICAL PLOT

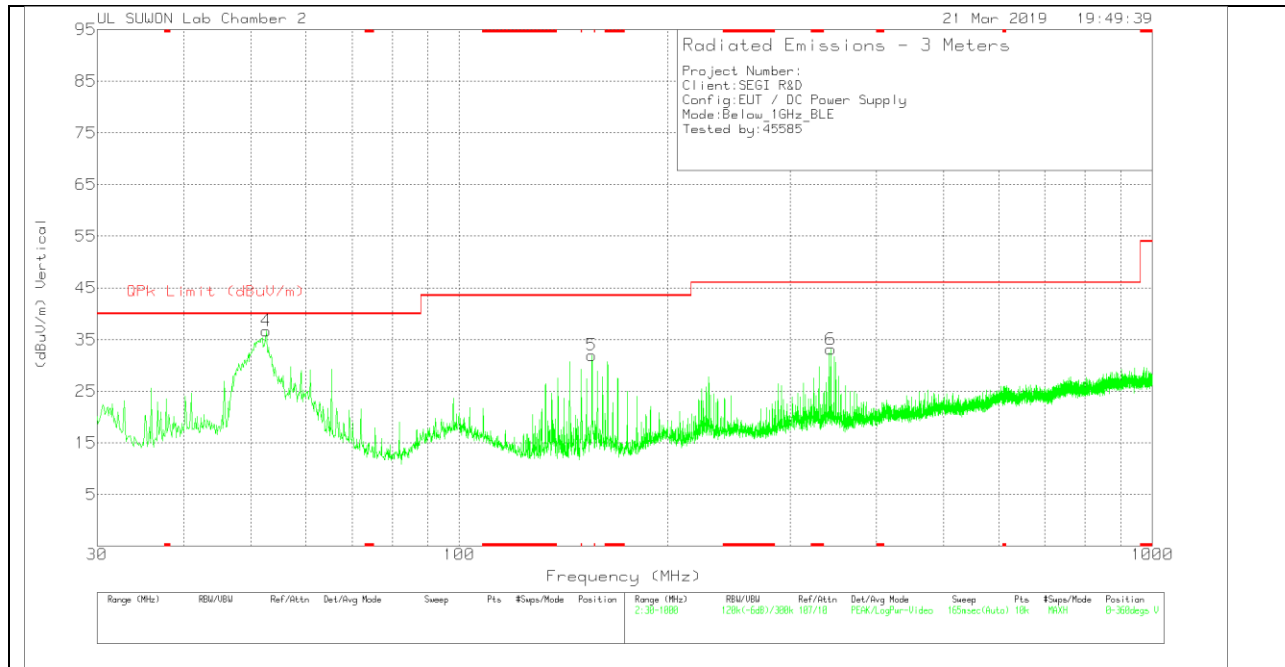

BELOW 1 GHz TABLE

Trace Markers

Marker	Frequency (MHz)	Meter Reading (dBuV)	Det	VULB9163_749	Below_1G[dB]	DC Corr (dB)	Corrected Reading (dBuV/m)	QPk Limit (dBuV/m)	Margin (dB)	Azimuth (Degs)	Height (cm)	Polarity
1	52.504	34.74	Pk	19.6	-31.8	0	22.54	40	-17.46	0-360	300	H
2	155.324	51.56	Pk	14.3	-31.1	0	34.76	43.52	-8.76	0-360	300	H
3	355.241	41.04	Pk	20.6	-30.3	0	31.34	46.02	-14.68	0-360	200	H
4	52.601	48.9	Pk	19.6	-31.8	0	36.7	40	-3.3	0-360	100	V
5	155.324	48.78	Pk	14.3	-31.1	0	31.98	43.52	-11.54	0-360	100	V
6	343.601	42.81	Pk	20.8	-30.5	0	33.11	46.02	-12.91	0-360	100	V

Pk - Peak detector

12. AC POWER LINE CONDUCTED EMISSIONS

LIMITS

FCC §15.207 (a)

Frequency of Emission (MHz)	Conducted Limit (dBuV)	
	Quasi-peak	Average
0.15-0.5	66 to 56	56 to 46
0.5-5	56	46
5-30	60	50

*Decreases with the logarithm of the frequency.

TEST PROCEDURE

The EUT is placed on a non-conducting table 40 cm from the vertical ground plane and 80 cm above the horizontal ground plane. The EUT is configured in accordance with ANSI C63.10.

The receiver is set to a resolution bandwidth of 9 kHz. Peak detection is used unless otherwise noted as quasi-peak or average.

Line conducted data is recorded for both NEUTRAL and HOT lines.

RESULTS (Not applicable)

This EUT is only supplied with DC power.