

9-4. Not-interrupt time setting: press "SET/FL" key to select "4", LCD display off r 00-00, when the letter flicker, input the time. Not-interrupt function is open, LCD display the time and count down until 00-00, after the Not-interrupt is cancel, hang on or press "SPK" can exit. In the Not-interrupt time, incoming ID not ring .

9-5. Special function select setting: press "SET/FL" key to select "5", LCD will display 1-F, 2-P-T, 3-DEF, then press "UP" "DOWNN" key or directly input number key into setting. select "1" into **FLASH time setting**, **press "UP" "DOWN" key select flash time, the flash time is 90,95,100,120,180,300,600,1000ms**; 2 don't need setting, default is tone state; select "3" into Non-theft setting, press "UP" "DOWN" to select on/off, "defend on" is open, "defend off" is off.

9-6. Special number setting: press "SET/FL" key to select "6", LCD will display 1-LOC 2-OL, Select "1" into area code set, input the number for 1-8. Secondly don't need setting.

9-7. LCD brightness adjust: press "SET/FL" key select "7", LCD display LCD con 3, then press "UP" "DOWN" to adjust the brightness. (1~5)

9-8.IP function setting: No need to set this function.

10. Put up function operation:

10-1. Incoming number inquire: use "UP" "DOWN" key to browse, and it will display the date and time of all incoming number.

10-2. Incoming number dial-back: when browse the number you want dial, use "BACK" key dial-back; if need add "0" dial-back, you can press "BACK" for 3 seconds.

10-3. Outgoing call inquire: press "OUT" key once, then press "UP" or "DOWN" to browse the outgoing call number.

10-4. Pre-dial: In on-hook state, directly input the telephone number, if input error, you can use "DEL" key delete and change it, finished input, press "SPK" key dial out the number.

10-5. Delete key: In on hook state, browse all the incoming and out number, use "DEL" key delete the number you want delete. Press "DEL" for 3 second, all number will delete; and you can use "DEL" key exit the setting too.

10-6. One-touch memory function: in the hand on state, input telephone number or press "UP" "DOWN" key browse the number, then press "M1" "M2" or "M3" key for second to save. LCD display "SAVE", means it saved. When we need the number, press "M1" "M2" or "M3" to pick up, the number will dial out

10-7. Two-touch function: in the hang on state, input telephone number or press "UP" "DOWN" key to browse the number, then press "MEMO" key for second, LCD display "SAVE-", then input the memory location (0-9). when we need the number, press "MEMO" key, LCD display Load, then input the number of memory location, the number will dial out.

10-8. Music hold: in the pick on state, press "HOLD" key into music hold, then put the handset back:

Pick up the handset, the music stop, automatically into handset talking.

Press "SPK" keys, the hold music stop, automatically into speaker mode.

10-9. Pause:

Press REDIAL in the process of dialing, an interval of 3.6 seconds will happen between the numbers before and after the pause. For example, if you press consecutively 123 REDIAL 456, then a pause of 3.6 seconds will occur between 123 and 456.

10. Appearance of BT-3000:

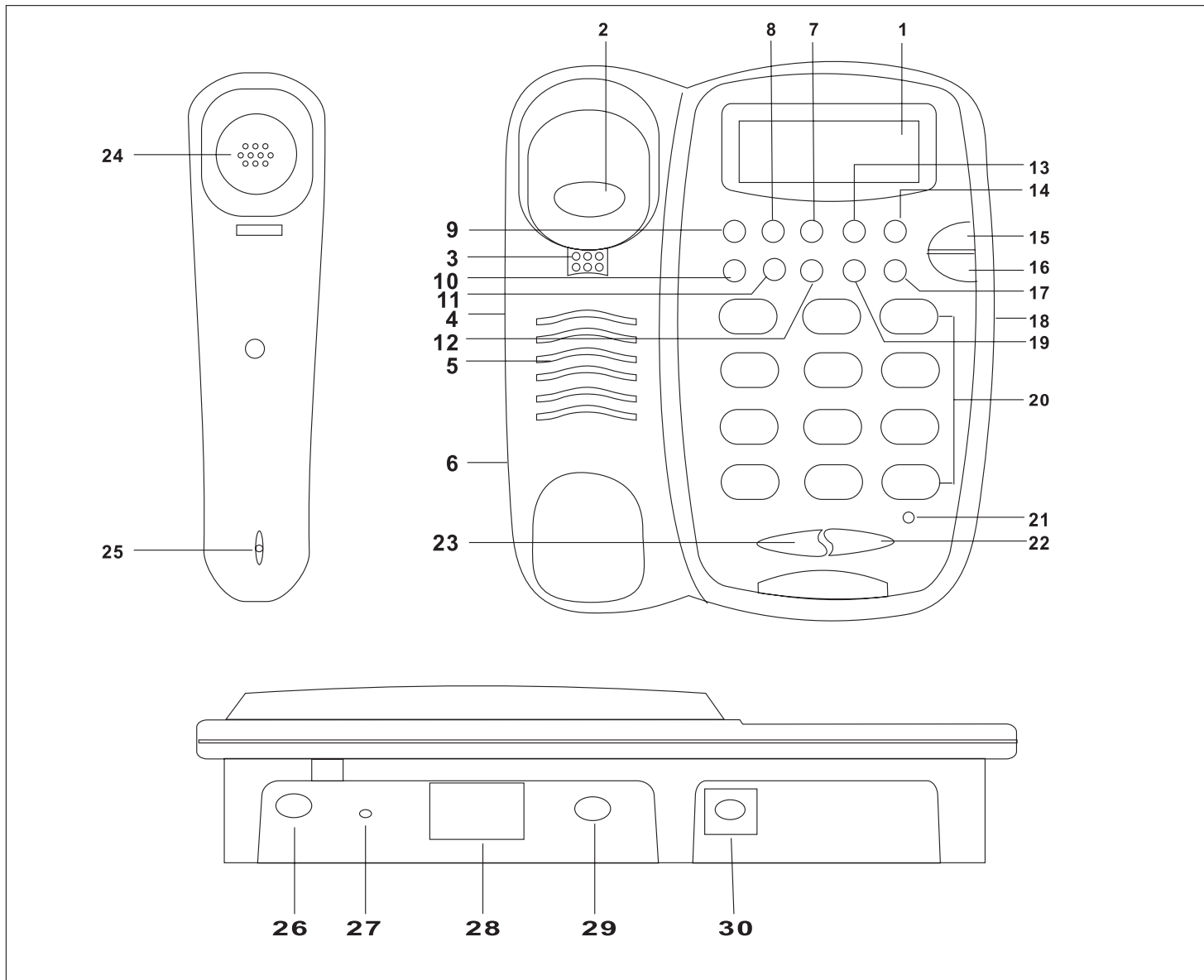

NO	Name	NO	Name	NO	Name	NO	Name
1	LED	9	UP	17	<i>PAIR</i>	25	Handset MIC
2	Off-Hook	10	<i>SET/FLASH</i>	18	DC-OUT 6V	26	ANTENNA
3	WALL Button	11	HOLD	19	MEMO	27	RESET
4	VC for Receiver/Speaker	12	OUT	20	Dial NO.	28	LINE JACK
5	SPEAKER	13	BACK	21	<i>LED(BT-3000)</i>	29	AUDIO JACK
6	Handset JACK	14	M3	22	<i>SPK</i>	30	Adaptor JACK
7	DELETE	15	M2	23	REDIAL		
8	DOWN	16	M1	24	RECEIVER		



12. Detail operation of bluetooth headset (bt-5) with Mobile:

Introduction

The Bluetooth wireless technology makes it possible to connect any compatible and stationary communications device without using cable. The technology is based on a radio link that offers fast and reliable transmission of voice and data information. It does not require a line-of-sight connection in order to establish communication. Bluetooth wireless technology uses a globally available frequency range intended to ensure worldwide communication compatibility.

Overview:

The headset contains the following parts

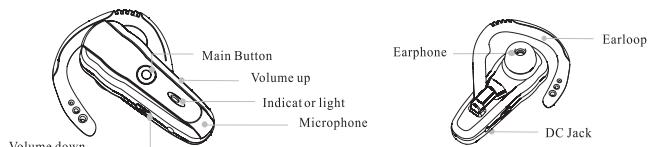

Preparing the Headset

To be able to use the Headset together with a mobile phone, you need to have a phone with Bluetooth system, or a phone with a Bluetooth adapter connected to it.

Charging

The Headset comes with a built-in rechargeable battery. The battery is not fully charged when you buy the Headset. We recommend that you charge the Headset to full power before use.

Charging the battery



Charging Method (Travel charger)

1. Insert the AC pin of the charger into power socket.
2. Insert the DC plug of the charger into earphone.
3. The Red LED turns on now, it will be off after it is full-charged (up to 2.5 hours).
4. After full-charged, it can last 4.0 hours in talking. The awaiting time can exceed 100 hours.

Low capacity

When the capacity of the battery is not enough, it will give caution, Red LED flashing.

ON&OFF of the earphone

1. ON: When the power is not on, press the main button for 6 seconds, it will ring two times, then the blue LED flashes 5 times.
2. Await: To save power, it will change mode from connection to awaiting, the blue LED flashes every 3 minutes.
3. OFF: At awaiting mode, press the main button for 3 seconds, it rings 2 times, blue LED OFF, Red LED flashes 5 times.

Matching of the earphone and mobile

Add the earphone to your mobile's menu, your mobile will be distinguished rapidly by the earphone when you use it next time.

1. In OFF status, press the main button for 9 seconds till the blue and red LED flashes.
2. Please read the instruction of your mobile to start the function of the Bluetooth and search the new device. Please be sure that the distance between your mobile and earphone is not far more than 5 meters.
3. Please choose "bt-5" appeared in the menu of your mobile, and key in "1234".
4. The earphone is connected, blue LED flashes 4 times in every 3 seconds.

Attentions:

1. You should match your mobile with the earphone at first time you use it.
2. After you matched with other mobiles, you should match again with the original one.
3. If it can't be matched, the earphone will be OFF. You should restart the steps of "Matching of the earphone and mobile" until it is matched successfully.
4. If the earphone has been connected with the mobile before, open earphone, namely auto link mobile.

Adjusting volume

1. Press the "volume down" in talking can lower the voice.
2. Press the "volume up" in talking can higher the voice.

Answer & Finish talking

1. Press the main button lightly to answer the phone.
2. If you answer it by mobile, the sound will remain in the phone, press the main button again, the sound will be in the earphone.
3. You can finish talking by pressing the main button.

Refusing coming calls

Press the button about 3 seconds until short tones is heard and then release the button.

Make a call

After matched your mobile with the earphone, you can make call with mobile and talk with earphone.

Voice dialing

1. Your mobile should have the function of voice dialing then the product can support this function.
2. Please start the voice dialing function as your mobile instruction showed.
3. When no call is in progress, press the main button, speak out the order stored in your mobile after the sound of "Be".

Redialing

Press the lower button about 3 seconds, when short tones is heard, release the button, the phone will display the redial number.

Right or left ear

If you want to wear the Headset on your left ear, you have to change the orientation of the ear hook. To adjust the ear hook for left-ear use.

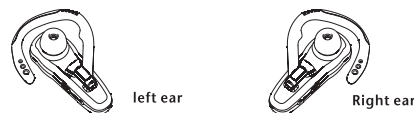

Putting on the Headset

Put on the Headset with the ear hook behind your ear. Make sure the microphone is towards your mouth.



Specification:

NO.	Item	Specification
1	Power	Polymer Li-ion battery 3.7V 120mAh
2	Operating Current	35mA
3	Carrier Frequency	2400MHz to 2483.5MHz
4	Modulation Method	GFSK
5	Maximum Data Rate	Asynchronous 723.2Kbps/57.6Kbps Synchronous 433.9Kbps/433.9Kbps
6	Transmission Power	+4dBm ~ -6dBm
7	Hopping	-80 ~ -20dBm
8	Operating Temperature	-10 ~ 50 °C
9	Storage Temperature	-20 ~ 75 °C
10	T.X. Distance	10m (spacial)
11	Awaiting time exceeds 100 hours, it remains 4.0h in talking.	



13. Enjoy Hand-free music with the external audio source:

13-1. Plug the Audio Line-in cable between the audio device and BT-3000:

13-1-1. Plug the black plug of audio line-in cable to BT-3000.

13-1-2. Plug the green terminal into audio device like Mp3 Player,

13-1-3. Switching the second channel from bt-5 via press its main button.

13-1-4. Enjoy hand-free music with bt-5.

13-2. Plug the Audio Line-in cable between the notebook or PC and BT-3000):

13-2-1. Plug the black plug of audio line-in cable to BT-3000.

13-2-2. Plug the green and pink terminal into the earphone and MIC in of Notebook/PC.

13-2-3. Switching the second channel from bt-5 via press its main button.

13-2-4. Enjoy MSN, Skype, AOL...two ways voice with bluetooth headset (bt-5).

14. Q & A:

14-1. May I pair other bluetooth headset?

A: Yes, please check its PIN of headset, BT-3000 supports 0000,1234,6666, 8888. Please plug your bluetooth headset device into pairing mode to pair with BT-3000. (Due to different method to produce headset. we do not guarantee its voice quality and it could not properly run with BT-3000).

14-2. If I still have problem for pairing link with bluetooth telephone, how do I do?

A: Try to push the reset button, please refer its location at P9, No.27. Re-Pair again. If still problem please call local distributor.

14-3. How many bluetooth device do I store in BT-3000?

A: The BT-3000 could store the latest 7 headsets which have been paired already.

14-4. When the noise occurs on bluetooth headset (bt-5)?

A: Low power battery, over limited distance, over two metal or cement walls for isolating, too close the interference source.

15. Service Center in USA:

Company: Visiondecor Company

TEL: +1-626-820-1250 #201 (Contact Person: Henry Lee)

FAX: +1-626.820.1252

Email1: service@bpvoice.com (Contact Person: Bob Chen)

Email2: henryl@visiondecor.com (Contact Person: Henry Lee)

167 Mason way, Suite A1, City of Industry, CA 91746, USA.

16. Warning:

Warning: Changes or modifications to this unit not expressly approved by the party responsible for compliance could void the user authority to operate the equipment.

"This device complies with Part 15 of the FCC Rules. Operation is subject to the following two conditions: (1) this device may not cause harmful interference, and (2) this device must accept any interference received, including interference that may cause undesired operation."

17. Note:

NOTE: This equipment has been tested and found to comply with the limits for a Class B digital device, pursuant to Part 15 of the FCC Rules. These limits are designed to provide reasonable protection against harmful interference in a residential installation. This equipment generates, uses and can radiate radio frequency energy and, if not installed and used in accordance with the instructions, may cause harmful interference to radio communications.

However, there is no guarantee that interference will not occur in a particular installation. If this equipment does cause harmful interference to radio or television reception, which can be determined by turning the equipment off and on, the user is encouraged to try to correct the interference by one or more of the following measures:

- Reorient or relocate the receiving antenna.
- Increase the separation between the equipment and receiver.
- Connect the equipment into an outlet on a circuit different from that to which the receiver is needed.
- Consult the dealer or an experienced radio/TV technician for help.