



## SAR EVALUATION REPORT

**Applicant Name:**  
 Kyocera Communication, Inc  
 8611 Balboa Ave  
 San Diego, CA 92123  
 USA

**Date of Testing:**  
 12/10/12 - 02/22/13  
**Test Site/Location:**  
 PCTEST Lab, Columbia, MD, USA  
**Document Serial No.:**  
 0Y1212071742-R4.V65

**FCC ID:** V65C6721A1

**APPLICANT:** KYOCERA COMMUNICATION, INC

**DUT Type:** Portable Handset  
**Application Type:** Certification  
**FCC Rule Part(s):** CFR §2.1093  
**Model(s):** C6721

Equipment Class	Band & Mode	Tx Frequency	Measured Conducted Power [dBm]	SAR		
				1 gm Head (W/kg)	1 gm Body-Worn (W/kg)	1 gm Hotspot (W/kg)
PCE	Cell. CDMA/EVDO	824.70 - 848.31 MHz	24.70	0.80	0.97	1.02
PCE	AWS CDMA/EVDO	1711.25 - 1753.75 MHz	23.88	0.77	0.52	0.52
PCE	PCS CDMA/EVDO	1851.25 - 1908.75 MHz	23.89	0.95	0.75	0.76
PCE	LTE Band 12	699.7 - 715.3 MHz	23.30	0.40	0.36	0.39
PCE	LTE Band 17	706.5 - 713.5 MHz	23.39	0.45	0.40	0.42
PCE	LTE Band 5 (Cell)	824.7 - 848.3 MHz	23.47	0.49	0.37	0.39
PCE	LTE Band 4 (AWS)	1710.7 - 1754.3 MHz	22.76	1.27	0.64	0.69
PCE	LTE Band 2 (PCS)	1850.7 - 1909.3 MHz	23.49	1.19	0.84	0.87
DTS	2.4 GHz WLAN	2412 - 2462 MHz	16.44	0.31	< 0.1	< 0.1
DSS/DTS	Bluetooth	2402 - 2480 MHz	2.08		N/A	
<b>Simultaneous SAR per KDB 690783 D01v01r02:</b>				1.49	1.42	1.42

Note: Powers in the above table represent output powers for the SAR test configurations and may not represent the highest output powers for all configurations for each mode.



This wireless portable device has been shown to be capable of compliance for localized specific absorption rate (SAR) for uncontrolled environment/general population exposure limits specified in ANSI/IEEE C95.1-1992 and has been tested in accordance with the measurement procedures specified in Section 1.7 of this report; for North American frequency bands only.

**\*This revised Test Report (S/ N: 0Y1212071742-R4.V65) supersedes and replaces the previously issued test report on the same subject EUT for the same type of testing as indicated. Please discard and destroy the previously issued test report (S/N:0Y1212071748.V65) and dispose of it accordingly.**

I attest to the accuracy of data. All measurements reported herein were performed by me or were made under my supervision and are correct to the best of my knowledge and belief. I assume full responsibility for the completeness of these measurements and vouch for the qualifications of all persons taking them. Test results reported herein relate only to the item(s) tested.



  
 Randy Ortanez  
 President



FCC ID: V65C6721A1	 SAR EVALUATION REPORT		Reviewed by: Quality Manager
Document S/N: 0Y1212071742-R4.V65	Test Dates: 12/10/12 - 02/22/13	DUT Type: Portable Handset	Page 1 of 82

# T A B L E O F C O N T E N T S

1	DEVICE UNDER TEST .....	3
2	LTE INFORMATION .....	7
3	INTRODUCTION .....	8
4	DOSIMETRIC ASSESSMENT .....	9
5	DEFINITION OF REFERENCE POINTS .....	10
6	TEST CONFIGURATION POSITIONS FOR HANDSETS .....	11
7	RF EXPOSURE LIMITS .....	14
8	FCC MEASUREMENT PROCEDURES .....	15
9	RF CONDUCTED POWERS .....	19
10	SYSTEM VERIFICATION .....	51
11	SAR DATA SUMMARY .....	53
12	FCC MULTI-TX AND ANTENNA SAR CONSIDERATIONS .....	65
13	SAR MEASUREMENT VARIABILITY .....	77
14	EQUIPMENT LIST .....	78
15	MEASUREMENT UNCERTAINTIES .....	79
16	CONCLUSION .....	80
17	REFERENCES .....	81
APPENDIX A: SAR TEST PLOTS		
APPENDIX B: SAR DIPOLE VERIFICATION PLOTS		
APPENDIX C: PROBE AND DIPOLE CALIBRATION CERTIFICATES		
APPENDIX D: SAR TISSUE SPECIFICATIONS		
APPENDIX E: SAR SYSTEM VALIDATION		
APPENDIX F: SAR TEST SETUP PHOTOGRAPHS		

FCC ID: V65C6721A1		SAR EVALUATION REPORT		Reviewed by: Quality Manager
Document S/N: 0Y1212071742-R4.V65	Test Dates: 12/10/12 - 02/22/13	DUT Type: Portable Handset		Page 2 of 82

# 1 DEVICE UNDER TEST

## 1.1 Device Overview

Band & Mode	Operating Modes	Tx Frequency
Cell. CDMA/EVDO	Voice/Data	824.70 - 848.31 MHz
AWS CDMA/EVDO	Voice/Data	1711.25 - 1753.75 MHz
PCS CDMA/EVDO	Voice/Data	1851.25 - 1908.75 MHz
LTE Band 12	Data	699.7 - 715.3 MHz
LTE Band 17	Data	706.5 - 713.5 MHz
LTE Band 5 (Cell)	Data	824.7 - 848.3 MHz
LTE Band 4 (AWS)	Data	1710.7 - 1754.3 MHz
LTE Band 2 (PCS)	Data	1850.7 - 1909.3 MHz
2.4 GHz WLAN	Data	2412 - 2462 MHz
Bluetooth	Data	2402 - 2480 MHz

## 1.2 Nominal and Maximum Output Power Specifications



This device operates using the following maximum and nominal output power specifications. SAR values were scaled to the maximum allowed power to determine compliance per KDB Publication 447498 D01v05.

Mode / Band		Modulated Average (dBm)	Modulated Average (dBm)	Modulated Average (dBm)
		Max	SVLTE Condition	SVLTE Condition
Cell. CDMA/EVDO	Maximum	<b>25.2</b>	<b>15.7</b>	<b>N/A</b>
	Nominal	<b>24.5</b>	<b>15.0</b>	<b>N/A</b>
PCS CDMA/EVDO	Maximum	<b>24.2</b>	<b>20.7</b>	<b>10.7</b>
	Nominal	<b>23.5</b>	<b>20.0</b>	<b>10.0</b>
AWS CDMA/EVDO	Maximum	<b>24.2</b>	<b>20.7</b>	<b>10.7</b>
	Nominal	<b>23.5</b>	<b>20.0</b>	<b>10.0</b>

Mode / Band		Modulated Average (dBm)	Modulated Average (dBm)	Modulated Average (dBm)
		Max	Reduced	Reduced
LTE Band 12	Maximum	<b>23.7</b>	<b>19.7</b>	<b>18.7</b>
	Nominal	<b>23.0</b>	<b>19.0</b>	<b>18.0</b>
LTE Band 17	Maximum	<b>23.7</b>	<b>20.2</b>	<b>19.2</b>
	Nominal	<b>23.0</b>	<b>19.5</b>	<b>18.5</b>
LTE Band 5 (Cell)	Maximum	<b>23.7</b>	<b>20.2</b>	<b>18.7</b>
	Nominal	<b>23.0</b>	<b>19.5</b>	<b>18.0</b>
LTE Band 4 (AWS)	Maximum	<b>23.2</b>	<b>19.7</b>	<b>15.7</b>
	Nominal	<b>22.5</b>	<b>19.0</b>	<b>15.0</b>
LTE Band 2 (PCS)	Maximum	<b>23.7</b>	<b>19.7</b>	<b>15.7</b>
	Nominal	<b>23.0</b>	<b>19.0</b>	<b>15.0</b>

Please refer to Section 10.1 for a detailed explanation of the SVLTE Power Reduction.

Mode / Band		Modulated Average (dBm)
IEEE 802.11b (2.4 GHz)	Maximum	<b>16.7</b>
	Nominal	<b>16.0</b>
IEEE 802.11g (2.4 GHz)	Maximum	<b>14.2</b>
	Nominal	<b>13.5</b>
IEEE 802.11n (2.4 GHz)	Maximum	<b>14.2</b>
	Nominal	<b>13.5</b>
Bluetooth	Maximum	<b>2.7</b>
	Nominal	<b>2.0</b>

FCC ID: V65C6721A1	 <b>PCTEST</b> ENGINEERING LABORATORY, INC.	<b>SAR EVALUATION REPORT</b>	 <b>KYOCERA</b>	Reviewed by: Quality Manager
Document S/N: 0Y1212071742-R4.V65	Test Dates: 12/10/12 - 02/22/13	DUT Type: Portable Handset	Page 3 of 82	

### 1.3 DUT Antenna Locations

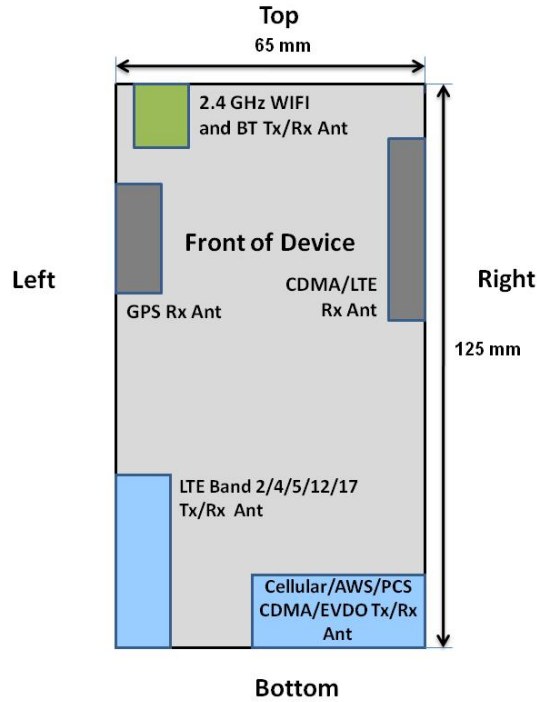



Note: Specific antenna dimensions and separation distances are shown in the antenna distance document.

**Figure 1-1**  
**DUT Antenna Locations**

**Table 1-1**  
**Mobile Hotspot Sides for SAR Testing**

Mobile Hotspot Sides for SAR Testing						
Mode	Back	Front	Top	Bottom	Right	Left
Cell. EVDO	Yes	Yes	No	Yes	Yes	No
AWS EVDO	Yes	Yes	No	Yes	Yes	No
PCS EVDO	Yes	Yes	No	Yes	Yes	No
LTE Band 12	Yes	Yes	No	Yes	No	Yes
LTE Band 17	Yes	Yes	No	Yes	No	Yes
LTE Band 5 (Cell)	Yes	Yes	No	Yes	No	Yes
LTE Band 4 (AWS)	Yes	Yes	No	Yes	No	Yes
LTE Band 2 (PCS)	Yes	Yes	No	Yes	No	Yes
2.4 GHz WLAN	Yes	Yes	Yes	No	No	Yes

Note: Particular DUT edges were not required to be evaluated for Wireless Router SAR if the edges were greater than 2.5 cm from the transmitting antenna according to FCC KDB Publication 941225 D06v01 guidance, page 2. The antenna document shows the distances between the transmit antennas and the edges of the device.

FCC ID: V65C6721A1	 <b>PCTEST</b> ENGINEERING LABORATORY, INC.	<b>SAR EVALUATION REPORT</b>	 <b>KYOCERA</b>	Reviewed by: Quality Manager
Document S/N: 0Y1212071742-R4.V65	Test Dates: 12/10/12 - 02/22/13	DUT Type: Portable Handset	Page 4 of 82	

## 1.4 Simultaneous Transmission Capabilities

According to FCC KDB Publication 447498 D05v01, transmitters are considered to be transmitting simultaneously when there is overlapping transmission, with the exception of transmissions during network hand-offs with maximum hand-off duration less than 30 seconds. Possible transmission paths for the DUT are shown in Figure 1-2 and are color-coded to indicate communication modes which share the same path. Modes which share the same transmission path cannot transmit simultaneously with one another.



Figure 1-2  
Simultaneous Transmission Paths

This device contains multiple transmitters that may operate simultaneously, and therefore requires a simultaneous transmission analysis according to FCC KDB Publication 447498 D01v05 3) procedures.

Table 1-2  
Simultaneous Transmission Scenarios

No.	Capable Transmit Configurations	Head	Body-Worn Accessory	Hotspot	Note
		IEEE 1528, Supplement C	Supplement C	FCC KDB 941225 D06 Edges/Sides	
1	CDMA Voice + Wifi 2.4 GHz	Yes	Yes	N/A	
2	EVDO Data + Wifi 2.4 GHz	Yes *	Yes *	Yes	2G Hotspot, VOIP
3	LTE + Wifi 2.4 GHz	Yes *	Yes *	Yes	4G Hotspot
4	CDMA Voice + LTE Data	Yes	Yes	N/A	SVLTE
5	CDMA Voice + LTE Data + Wifi 2.4 GHz	Yes	Yes	Yes	SVLTE Hotspot
6	CDMA Voice + 2.4 GHz Bluetooth	N/A	Yes	N/A	
7	LTE + 2.4 GHz Bluetooth	N/A	Yes	N/A	
8	CDMA Voice + LTE Data + 2.4 GHz Bluetooth	N/A	Yes	N/A	SVLTE
9	EVDO Data + LTE	N/A	N/A	N/A	Not supported by S/W
10	CDMA Voice + EVDO Data	N/A	N/A	N/A	Not supported by H/W

(\*) = for VOIP 3<sup>rd</sup> party applications possibly installed and used by the end-user

## 1.5 SAR Test Exclusions Applied

### (A) WIFI/BT

Per FCC KDB 447498 D01 v05, the SAR exclusion threshold for distances <50mm is defined by the following equation:

$$\frac{\text{Max Power of Channel (mW)}}{\text{Test Separation Dist (mm)}} * \sqrt{\text{Frequency(GHz)}} \leq 3.0$$

Based on the maximum conducted power of Bluetooth (rounded to the nearest mW) and the antenna to user separation distance, Bluetooth SAR was not required;  $[(2/10) * \sqrt{2.441}] = 0.3 < 3.0$ .

FCC ID: V65C6721A1	PCTEST ENGINEERING LABORATORY, INC.	SAR EVALUATION REPORT	KYOCERA	Reviewed by: Quality Manager
Document S/N: 0Y1212071742-R4.V65	Test Dates: 12/10/12 - 02/22/13	DUT Type: Portable Handset		Page 5 of 82

**(B) Licensed Transmitter(s)**

LTE SAR for the higher modulations and lower bandwidths were not tested since the maximum average output power of all required channels and configurations was not more than 0.5 dB higher than the highest bandwidth; and the reported LTE SAR for the highest bandwidth was less than 1.45 W/kg for all configurations according to FCC KDB 941225 D05v02.

**1.6 Power Reduction for SAR**

This device uses power reduction mechanisms for LTE during SVLTE operation (1x-RTT CDMA voice + LTE data) for SAR compliance. See Section 10 for more details..

**1.7 Guidance Applied**



- FCC OET Bulletin 65 Supplement C [June 2001]
- IEEE 1528-2003
- FCC KDB Publication 941225 D01-D06 (2G/3G/4G and Hotspot)
- FCC KDB Publication 248227 D01v01r02 (SAR Considerations for 802.11 Devices)
- FCC KDB Publication 447498 D01v05 (General SAR Guidance)
- FCC KDB Publication 865664 D01-D02 (SAR Measurements up to 6 GHz)

**1.8 Device Serial Numbers**

Several samples were used with identical hardware to support SAR testing.

	Head Serial Number	Body-Worn Serial Number	Hotspot Serial Number
Cell. CDMA/EVDO	SAR CDMA - BC0	SAR CDMA - BC0	SAR CDMA - BC0
AWS CDMA/EVDO	SAR CDMA - BC15	SAR CDMA - BC15	SAR CDMA - BC15
PCS CDMA/EVDO	SAR CDMA - BC1	SAR CDMA - BC1	SAR CDMA - BC1
LTE Band 12	LTE SAR/HAC, SAR LTE - Band 5/12/17	LTE SAR/HAC, SAR LTE - Band 5/12/17	LTE SAR/HAC, SAR LTE - Band 5/12/17
LTE Band 17	LTE SAR/HAC, SAR LTE - Band 5/12/17	LTE SAR/HAC, SAR LTE - Band 5/12/17	LTE SAR/HAC, SAR LTE - Band 5/12/17
LTE Band 5 (Cell)	LTE SAR/HAC, SAR LTE - Band 5/12/17	LTE SAR/HAC, SAR LTE - Band 5/12/17	LTE SAR/HAC, SAR LTE - Band 5/12/17
LTE Band 4 (AWS)	SAR LTE - Band4	SAR LTE - Band 4	SAR LTE - Band 4
LTE Band 2 (PCS)	SAR LTE - Band2	SAR LTE - Band2	SAR LTE - Band2
2.4 GHz WLAN	WIFI/BT RADIATION	WIFI/BT RADIATION	WIFI/BT RADIATION



Note: Per KDB 941225 D05v02 Section 4.4 B), SAR testing was additionally performed at the reduced CDMA and LTE power levels with respect to the simultaneous transmission scenarios. Each sample was tuned to fixed reduced power levels to represent the SVLTE condition in a standalone environment.

FCC ID: V65C6721A1	 <b>PCTEST</b> ENGINEERING LABORATORY, INC.	<b>SAR EVALUATION REPORT</b>	 <b>KYOCERA</b>	Reviewed by: Quality Manager
Document S/N: 0Y1212071742-R4.V65	Test Dates: 12/10/12 - 02/22/13	DUT Type: Portable Handset	Page 6 of 82	

## 2

## LTE INFORMATION

LTE Information			
<b>FCC ID</b>	<b>V65C6721A1</b>		
Form Factor	Portable Handset		
Frequency Range of each LTE transmission band	LTE Band 12 (699.7 - 715.3 MHz)		
	LTE Band 5 (Cell) (824.7 - 848.3 MHz)		
	LTE Band 4 (AWS) (1710.7 - 1754.3 MHz)		
	LTE Band 2 (PCS) (1850.7 - 1909.3 MHz)		
	LTE Band 17 (706.5 - 713.5 MHz)		
Channel Bandwidths	LTE Band 12: 1.4 MHz, 3 MHz, 5 MHz, 10 MHz		
	LTE Band 5 (Cell): 1.4 MHz, 3 MHz, 5 MHz, 10 MHz		
	LTE Band 4 (AWS): 1.4 MHz, 3 MHz, 5 MHz, 10 MHz		
	LTE Band 2 (PCS): 1.4 MHz, 3 MHz, 5 MHz, 10 MHz		
	LTE Band 17: 5 MHz, 10 MHz		
Channel Numbers and Frequencies (MHz)	Low	Mid	High
LTE Band 12: 1.4 MHz	699.7 (23017)	707.5 (23095)	715.3 (23173)
LTE Band 12: 3 MHz	700.5 (23025)	707.5 (23095)	714.5 (23165)
LTE Band 12: 5 MHz	701.5 (23035)	707.5 (23095)	713.5 (23155)
LTE Band 12: 10 MHz	704 (23060)	707.5 (23095)	711 (23130)
LTE Band 17: 5 MHz	706.5 (23755)	710 (23790)	713.5 (23825)
LTE Band 17: 10 MHz	709 (23780)	710 (23790)	711 (23800)
LTE Band 5 (Cell): 1.4 MHz	824.7 (20407)	836.5 (20525)	848.3 (20643)
LTE Band 5 (Cell): 3 MHz	825.5 (20415)	836.5 (20525)	847.5 (20635)
LTE Band 5 (Cell): 5 MHz	826.5 (20425)	836.5 (20525)	846.5 (20625)
LTE Band 5 (Cell): 10 MHz	829 (20450)	836.5 (20525)	844 (20600)
LTE Band 4 (AWS): 1.4 MHz	1710.7 (19957)	1732.5 (20175)	1754.3 (20393)
LTE Band 4 (AWS): 3 MHz	1711.5 (19965)	1732.5 (20175)	1753.5 (20385)
LTE Band 4 (AWS): 5 MHz	1712.5 (19975)	1732.5 (20175)	1752.5 (20375)
LTE Band 4 (AWS): 10 MHz	1715 (20000)	1732.5 (20175)	1750 (20350)
LTE Band 2 (PCS): 1.4 MHz	1850.7 (18607)	1880 (18900)	1909.3 (19193)
LTE Band 2 (PCS): 3 MHz	1851.5 (18615)	1880 (18900)	1908.5 (19185)
LTE Band 2 (PCS): 5 MHz	1852.5 (18625)	1880 (18900)	1907.5 (19175)
LTE Band 2 (PCS): 10 MHz	1855 (18650)	1880 (18900)	1905 (19150)
UE Category	3		
Modulations Supported in UL	QPSK, 16QAM		
LTE Transmitter and Antenna Implementation	1 Antenna for LTE Tx/Rx and one for LTE Rx		
Description of LTE Tx and Ant. Implementation	CDMA/LTE operate on separate transmission paths		
Hotspot with LTE+WIFI	YES		
Hotspot with LTE+WIFI active with 1XVoice sessions?	YES		
LTE MPR Permanently implemented per 3GPP TS 36.101 section 6.2.3~6.2.5? (manufacturer attestation to be provided)	YES		
A-MPR (Additional MPR) disabled for SAR Testing?	YES		
Conducted powers included for 1RB (low, mid, and high offset), 50% RB (low, mid, and high offset), 100% RB	YES		

FCC ID: V65C6721A1	 <b>PCTEST</b> ENGINEERING LABORATORY, INC.	<b>SAR EVALUATION REPORT</b>	 <b>KYOCERA</b>	Reviewed by: Quality Manager
Document S/N: 0Y1212071742-R4.V65	Test Dates: 12/10/12 - 02/22/13	DUT Type: Portable Handset	Page 7 of 82	

### 3 INTRODUCTION

The FCC and Industry Canada have adopted the guidelines for evaluating the environmental effects of radio frequency (RF) radiation in ET Docket 93-62 on Aug. 6, 1996 and Health Canada Safety Code 6 to protect the public and workers from the potential hazards of RF emissions due to FCC-regulated portable devices. [1]

The safety limits used for the environmental evaluation measurements are based on the criteria published by the American National Standards Institute (ANSI) for localized specific absorption rate (SAR) in IEEE/ANSI C95.1-1992 Standard for Safety Levels with Respect to Human Exposure to Radio Frequency Electromagnetic Fields, 3 kHz to 300 GHz [3] and Health Canada RF Exposure Guidelines Safety Code 6 [24]. The measurement procedure described in IEEE/ANSI C95.3-2002 Recommended Practice for the Measurement of Potentially Hazardous Electromagnetic Fields - RF and Microwave [4] is used for guidance in measuring the Specific Absorption Rate (SAR) due to the RF radiation exposure from the Equipment Under Test (EUT). These criteria for SAR evaluation are similar to those recommended by the International Committee for Non-Ionizing Radiation Protection (ICNIRP) in Biological Effects and Exposure Criteria for Radiofrequency Electromagnetic Fields," Report No. Vol 74. SAR is a measure of the rate of energy absorption due to exposure to an RF transmitting source. SAR values have been related to threshold levels for potential biological hazards.

#### 3.1 SAR Definition

Specific Absorption Rate is defined as the time derivative (rate) of the incremental energy (dU) absorbed by (dissipated in) an incremental mass (dm) contained in a volume element (dV) of a given density ( $\rho$ ). It is also defined as the rate of RF energy absorption per unit mass at a point in an absorbing body (see Equation 3-1).

Equation 3-1  
SAR Mathematical Equation

$$SAR = \frac{d}{dt} \left( \frac{dU}{dm} \right) = \frac{d}{dt} \left( \frac{dU}{\rho dv} \right)$$



SAR is expressed in units of Watts per Kilogram (W/kg).

$$SAR = \frac{\sigma \cdot E^2}{\rho}$$

where:

- $\sigma$  = conductivity of the tissue-simulating material (S/m)
- $\rho$  = mass density of the tissue-simulating material (kg/m<sup>3</sup>)
- E = Total RMS electric field strength (V/m)

NOTE: The primary factors that control rate of energy absorption were found to be the wavelength of the incident field in relation to the dimensions and geometry of the irradiated organism, the orientation of the organism in relation to the polarity of field vectors, the presence of reflecting surfaces, and whether conductive contact is made by the organism with a ground plane.[6]

FCC ID: V65C6721A1	 <b>PCTEST</b> ENGINEERING LABORATORY, INC.	SAR EVALUATION REPORT	 <b>KYOCERA</b>	Reviewed by: Quality Manager
Document S/N: 0Y1212071742-R4.V65	Test Dates: 12/10/12 - 02/22/13	DUT Type: Portable Handset	Page 8 of 82	



## 4 DOSIMETRIC ASSESSMENT

### 4.1 Measurement Procedure

The evaluation was performed using the following procedure:

1. The SAR distribution at the exposed side of the head or body was measured at a distance no greater than 5.0 mm from the inner surface of the shell. The area covered the entire dimension of the device-head and body interface and the horizontal grid resolution was determined per FCC KDB Publication 865664 D01v01 (See Table 4-1).
2. The point SAR measurement was taken at the maximum SAR region determined from Step 1 to enable the monitoring of SAR fluctuations/drifts during the 1g/10g cube evaluation. SAR at this fixed point was measured and used as a reference value.
3. Based on the area scan data, the peak of the region with maximum SAR was determined by spline interpolation. Around this point, a volume was assessed according to the measurement resolution and volume size requirements of FCC KDB Publication 865664 D01v01 (See Table 4-1). On the basis of this data set, the spatial peak SAR value was evaluated with the following procedure (see references or the DASYS manual online for more details):
  - a. The data was extrapolated to the surface of the outer-shell of the phantom. The combined distance extrapolated was the combined distance from the center of the dipoles 2.7mm away from the tip of the probe housing plus the 1.2 mm distance between the surface and the lowest measuring point. The extrapolation was based on a least-squares algorithm. A polynomial of the fourth order was calculated through the points in the z-axis (normal to the phantom shell).
  - b. After the maximum interpolated values were calculated between the points in the cube, the SAR was averaged over the spatial volume (1g or 10g) using a 3D-Spline interpolation algorithm. The 3D-spline is composed of three one-dimensional splines with the “Not a knot” condition (in x, y, and z directions). The volume was then integrated with the trapezoidal algorithm. One thousand points (10 x 10 x 10) were obtained through interpolation, in order to calculate the averaged SAR.
  - c. All neighboring volumes were evaluated until no neighboring volume with a higher average value was found.
4. The SAR reference value, at the same location as step 2, was re-measured after the zoom scan was complete to calculate the SAR drift. If the drift deviated by more than 5%, the SAR test and drift measurements were repeated.

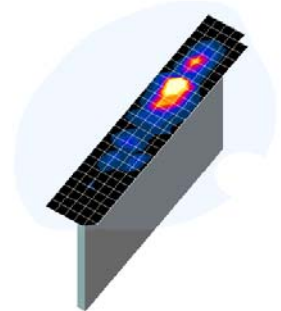

**Figure 4-1**  
**Sample SAR Area Scan**

**Table 4-1**  
**Area and Zoom Scan Resolutions per FCC KDB Publication 865664 D01v01**

Frequency	Maximum Area Scan Resolution (mm) ( $\Delta x_{\text{area}}, \Delta y_{\text{area}}$ )	Maximum Zoom Scan Resolution (mm) ( $\Delta x_{\text{zoom}}, \Delta y_{\text{zoom}}$ )	Maximum Zoom Scan Spatial Resolution (mm)			Minimum Zoom Scan Volume (mm) (x, y, z)
			Uniform Grid	Graded Grid		
			$\Delta z_{\text{zoom}}(n)$	$\Delta z_{\text{zoom}}(1)^*$	$\Delta z_{\text{zoom}}(n>1)^*$	
≤ 2 GHz	≤ 15	≤ 8	≤ 5	≤ 4	≤ 1.5* $\Delta z_{\text{zoom}}(n-1)$	≥ 30
2-3 GHz	≤ 12	≤ 5	≤ 5	≤ 4	≤ 1.5* $\Delta z_{\text{zoom}}(n-1)$	≥ 30
3-4 GHz	≤ 12	≤ 5	≤ 4	≤ 3	≤ 1.5* $\Delta z_{\text{zoom}}(n-1)$	≥ 28
4-5 GHz	≤ 10	≤ 4	≤ 3	≤ 2.5	≤ 1.5* $\Delta z_{\text{zoom}}(n-1)$	≥ 25
5-6 GHz	≤ 10	≤ 4	≤ 2	≤ 2	≤ 1.5* $\Delta z_{\text{zoom}}(n-1)$	≥ 22

FCC ID: V65C6721A1	<b>PCTEST</b> <small>ENGINEERING LABORATORY, INC.</small>	<b>SAR EVALUATION REPORT</b>	<b>KYOCERA</b>	Reviewed by: Quality Manager
Document S/N: 0Y1212071742-R4.V65	Test Dates: 12/10/12 - 02/22/13	DUT Type: Portable Handset		Page 9 of 82

# 5 DEFINITION OF REFERENCE POINTS

## 5.1 EAR REFERENCE POINT

Figure 5-2 shows the front, back and side views of the SAM Twin Phantom. The point “M” is the reference point for the center of the mouth, “LE” is the left ear reference point (ERP), and “RE” is the right ERP. The ERP is 15mm posterior to the entrance to the ear canal (EEC) along the B-M line (Back-Mouth), as shown in Figure 5-1. The plane passing through the two ear canals and M is defined as the Reference Plane. The line N-F (Neck-Front) is perpendicular to the reference plane and passing through the RE (or LE) is called the Reference Pivoting Line (see Figure 5-1). Line B-M is perpendicular to the N-F line. Both N-F and B-M lines are marked on the external phantom shell to facilitate handset positioning [5].

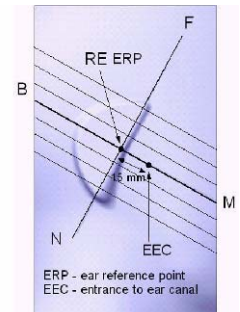

**Figure 5-1**  
Close-Up Side view of ERP

## 5.2 HANDSET REFERENCE POINTS



Two imaginary lines on the handset were established: the vertical centerline and the horizontal line. The test device was placed in a normal operating position with the “test device reference point” located along the “vertical centerline” on the front of the device aligned to the “ear reference point” (See Figure 5-3). The transducer is technology specific and the center of the transducer (as identified in the Technical Descriptions) was used as the “test device reference point”, for Head SAR testing. The test device was positioned so that the “vertical centerline” was bisecting the front surface of the handset at its top and bottom edges, positioning the “ear reference point” on the outer surface of the both the left and right head phantoms on the ear reference point.

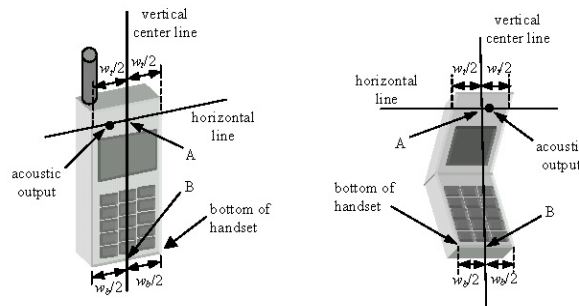

**Figure 5-2**  
Front, back and side view of SAM Twin Phantom



**Figure 5-3**  
Handset Vertical Center & Horizontal Line Reference Points

FCC ID: V65C6721A1	 PCTEST ENGINEERING LABORATORY, INC.	SAR EVALUATION REPORT	 KYOCERA	Reviewed by: Quality Manager
Document S/N: 0Y1212071742-R4.V65	Test Dates: 12/10/12 - 02/22/13	DUT Type: Portable Handset		Page 10 of 82

## 6 TEST CONFIGURATION POSITIONS FOR HANDSETS

### 6.1 Device Holder

The device holder is made out of low-loss POM material having the following dielectric parameters: relative permittivity  $\epsilon = 3$  and loss tangent  $\delta = 0.02$ .

### 6.2 Positioning for Cheek

1. The test device was positioned with the device close to the surface of the phantom such that point A is on the (virtual) extension of the line passing through points RE and LE on the phantom (see Figure 6-1), such that the plane defined by the vertical center line and the horizontal line of the phone is approximately parallel to the sagittal plane of the phantom.

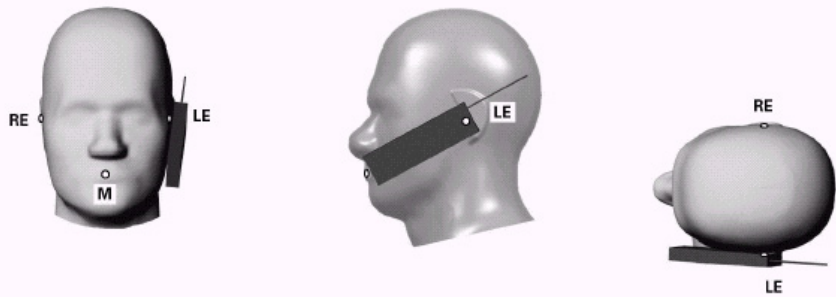



Figure 6-1 Front, Side and Top View of Cheek Position

2. The handset was translated towards the phantom along the line passing through RE & LE until the handset touches the ear.
3. While maintaining the handset in this plane, the handset was rotated around the LE-RE line until the vertical centerline was in the plane normal to MB-NF including the line MB (reference plane).
4. The phone was then rotated around the vertical centerline until the phone (horizontal line) was symmetrical with respect to the line NF.
5. While maintaining the vertical centerline in the reference plane, keeping point A on the line passing through RE and LE, and maintaining the device contact with the ear, the device was rotated about the NF line until any point on the handset made contact with a phantom point below the ear (cheek) (See Figure 6-2).

### 6.3 Positioning for Ear / 15° Tilt

With the test device aligned in the “Cheek Position”:

1. While maintaining the orientation of the phone, the phone was retracted parallel to the reference plane far enough to enable a rotation of the phone by 15 degrees.
2. The phone was then rotated around the horizontal line by 15 degrees.
3. While maintaining the orientation of the phone, the phone was moved parallel to the reference plane until any part of the handset touched the head. (In this position, point A was located on the line RE-LE). The tilted position is obtained when the contact is on the pinna. If the contact was at any location other than the pinna, the angle of the phone would then be reduced. The tilted position was obtained when any part of the phone was in contact of the ear as well as a second part of the phone was in contact with the head (see Figure 6-2).

FCC ID: V65C6721A1	 PCTEST ENGINEERING LABORATORY, INC.	SAR EVALUATION REPORT	 KYOCERA	Reviewed by: Quality Manager
Document S/N: 0Y1212071742-R4.V65	Test Dates: 12/10/12 - 02/22/13	DUT Type: Portable Handset		Page 11 of 82

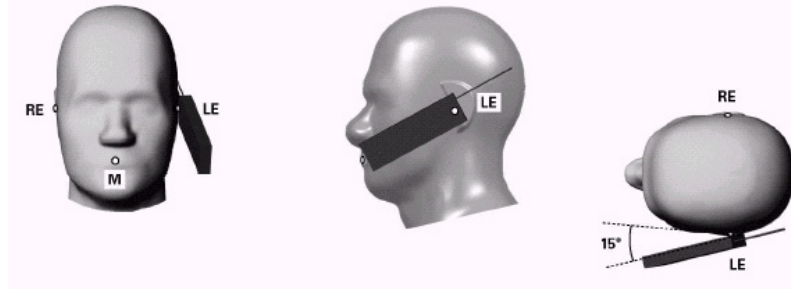

**Figure 6-2 Front, Side and Top View of Ear/15° Tilt Position**

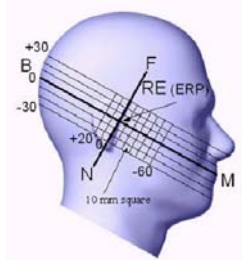

**Figure 6-3 Side view w/ relevant markings**

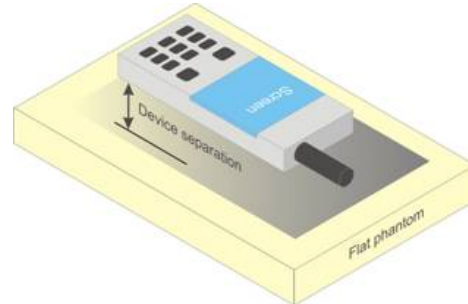

**Figure 6-4 Sample Body-Worn Diagram**

## 6.4 SAR Evaluations near the Mouth/Jaw Regions of the SAM Phantom



Antennas located near the bottom of a phone may require SAR measurements around the mouth and jaw regions of the SAM head phantom. This typically applies to clam-shell style phones that are generally longer in the unfolded normal use positions or to certain older style long rectangular phones.

Under these circumstances, the following procedures apply, adopted from the FCC guidance on SAR handsets document FCC KDB Publication 648474 D04\_v01. The SAR required in these regions of SAM should be measured using a flat phantom. The phone should be positioned with a separation distance of 4 mm between the ear reference point (ERP) and the outer surface of the flat phantom shell. While maintaining this distance at the ERP location, the low (bottom) edge of the phone should be lowered from the phantom to establish the same separation distance between the peak SAR location identified by the truncated partial SAR distribution measured with the SAM phantom. The distance from the peak SAR location to the phone is determined by the straight line passing perpendicularly through the phantom surface. When it is not feasible to maintain 4 mm separation at the ERP while also establishing the required separation at the peak SAR location, the top edge of the phone will be allowed to touch the phantom with a separation < 4 mm at the ERP. The phone should not be tilted to the left or right while placed in this inclined position to the flat phantom.

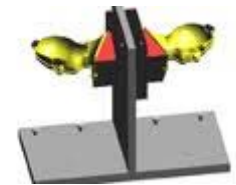
The latest IEEE 1528 committee developments propose the usage of a tilted phantom when the antenna of the phone is mounted at the bottom or in all cases the peak absorption is in the chin region. Both SAM heads of the TwinSAM-Chin20 are rotated 20 degrees around the NF line. Each head can be removed individually from the table for emptying and cleaning.



**Figure 6-5 Twin SAM Chin20**

FCC ID: V65C6721A1	 PCTEST ENGINEERING LABORATORY, INC.	SAR EVALUATION REPORT	 KYOCERA	Reviewed by: Quality Manager
Document S/N: 0Y1212071742-R4.V65	Test Dates: 12/10/12 - 02/22/13	DUT Type: Portable Handset		Page 12 of 82

## 6.5 Body-Worn Accessory Configurations

Body-worn operating configurations are tested with the belt-clips and holsters attached to the device and positioned against a flat phantom in a normal use configuration (see Figure 6-4). Per FCC KDB Publication 648474 D04\_v01, Body-worn accessory exposure is typically related to voice mode operations when handsets are carried in body-worn accessories. The body-worn accessory procedures in FCC KDB Publication 447498 D01\_v05 should be used to test for body-worn accessory SAR compliance, without a headset connected to it. This enables the test results for such configuration to be compatible with that required for hotspot mode when the body-worn accessory test separation distance is greater than or equal to that required for hotspot mode, when applicable. When the reported SAR for a body-worn accessory, measured without a headset connected to the handset, is  $> 1.2$  W/kg, the highest reported SAR configuration for that wireless mode and frequency band should be repeated for that body-worn accessory with a headset attached to the handset.



Accessories for Body-worn operation configurations are divided into two categories: those that do not contain metallic components and those that do contain metallic components. When multiple accessories that do not contain metallic components are supplied with the device, the device is tested with only the accessory that dictates the closest spacing to the body. Then multiple accessories that contain metallic components are tested with the device with each accessory. If multiple accessories share an identical metallic component (i.e. the same metallic belt-clip used with different holsters with no other metallic components) only the accessory that dictates the closest spacing to the body is tested.

Body-worn accessories may not always be supplied or available as options for some devices intended to be authorized for body-worn use. In this case, a test configuration with a separation distance between the back of the device and the flat phantom is used. Test position spacing was documented. Transmitters that are designed to operate in front of a person's face, as in push-to-talk configurations, are tested for SAR compliance with the front of the device positioned to face the flat phantom in head fluid. For devices that are carried next to the body such as a shoulder, waist or chest-worn transmitters, SAR compliance is tested with the accessories, including headsets and microphones, attached to the device and positioned against a flat phantom in a normal use configuration.

## 6.6 Wireless Router Configurations

Some battery-operated handsets have the capability to transmit and receive user data through simultaneous transmission of WIFI simultaneously with a separate licensed transmitter. The FCC has provided guidance in FCC KDB Publication 941225 D06 v01 where SAR test considerations for handsets ( $L \times W \geq 9$  cm  $\times$  5 cm) are based on a composite test separation distance of 10 mm from the front, back and edges of the device containing transmitting antennas within 2.5 cm of their edges, determined from general mixed use conditions for this type of devices. Since the hotspot SAR results may overlap with the body-worn accessory SAR requirements, the more conservative configurations can be considered, thus excluding some body-worn accessory SAR tests.

When the user enables the personal wireless router functions for the handset, actual operations include simultaneous transmission of both the WIFI transmitter and another licensed transmitter. Both transmitters often do not transmit at the same transmitting frequency and thus cannot be evaluated for SAR under actual use conditions due to the limitations of the SAR assessment probes. Therefore, SAR must be evaluated for each frequency transmission and mode separately and spatially summed with the WIFI transmitter according to FCC KDB Publication 447498 D01v05 publication procedures. The "Portable Hotspot" feature on the handset was NOT activated during SAR assessments, to ensure the SAR measurements were evaluated for a single transmission frequency RF signal at a time.

FCC ID: V65C6721A1	 <b>PCTEST</b> ENGINEERING LABORATORY, INC.	<b>SAR EVALUATION REPORT</b>	 <b>KYOCERA</b>	Reviewed by: Quality Manager
Document S/N: 0Y1212071742-R4.V65	Test Dates: 12/10/12 - 02/22/13	DUT Type: Portable Handset		Page 13 of 82

# 7 RF EXPOSURE LIMITS

## 7.1 Uncontrolled Environment

UNCONTROLLED ENVIRONMENTS are defined as locations where there is the exposure of individuals who have no knowledge or control of their exposure. The general population/uncontrolled exposure limits are applicable to situations in which the general public may be exposed or in which persons who are exposed as a consequence of their employment may not be made fully aware of the potential for exposure or cannot exercise control over their exposure. Members of the general public would come under this category when exposure is not employment-related; for example, in the case of a wireless transmitter that exposes persons in its vicinity.



## 7.2 Controlled Environment

CONTROLLED ENVIRONMENTS are defined as locations where there is exposure that may be incurred by persons who are aware of the potential for exposure, (i.e. as a result of employment or occupation). In general, occupational/controlled exposure limits are applicable to situations in which persons are exposed as a consequence of their employment, who have been made fully aware of the potential for exposure and can exercise control over their exposure. This exposure category is also applicable when the exposure is of a transient nature due to incidental passage through a location where the exposure levels may be higher than the general population/uncontrolled limits, but the exposed person is fully aware of the potential for exposure and can exercise control over his or her exposure by leaving the area or by some other appropriate means.

**Table 7-1**  
**SAR Human Exposure Specified in ANSI/IEEE C95.1-1992 and Health Canada Safety Code 6**

HUMAN EXPOSURE LIMITS		
	UNCONTROLLED ENVIRONMENT <i>General Population</i> (W/kg) or (mW/g)	CONTROLLED ENVIRONMENT <i>Occupational</i> (W/kg) or (mW/g)
SPATIAL PEAK SAR Brain	1.6	8.0
SPATIAL AVERAGE SAR Whole Body	0.08	0.4
SPATIAL PEAK SAR Hands, Feet, Ankles, Wrists	4.0	20

1. The Spatial Peak value of the SAR averaged over any 1 gram of tissue (defined as a tissue volume in the shape of a cube) and over the appropriate averaging time.
2. The Spatial Average value of the SAR averaged over the whole body.
3. The Spatial Peak value of the SAR averaged over any 10 grams of tissue (defined as a tissue volume in the shape of a cube) and over the appropriate averaging time.

FCC ID: V65C6721A1	 <b>PCTEST</b> ENGINEERING LABORATORY, INC.	<b>SAR EVALUATION REPORT</b>	 <b>KYOCERA</b>	Reviewed by: Quality Manager
Document S/N: 0Y1212071742-R4.V65	Test Dates: 12/10/12 - 02/22/13	DUT Type: Portable Handset	Page 14 of 82	



## 8 FCC MEASUREMENT PROCEDURES

Power measurements were performed using a base station simulator under digital average power.

### 8.1 Measured and Reported SAR

Per FCC KDB Publication 447498 D01v05, When SAR is not measured at the maximum power level allowed for production units, the results must be scaled to the maximum tune-up tolerance limit according to the power applied to the individual channels tested to determine compliance. For simultaneous transmission, the measured aggregate SAR must be scaled according to the sum of the differences between the maximum tune-up tolerance and actual power used to test each transmitter. When SAR is measured at or scaled to the maximum tune-up tolerance limit, the results are referred to as *reported* SAR. The highest *reported* SAR results are identified on the grant of equipment authorization according to procedures in KDB 690783 D01v01r02.

### 8.2 Procedures Used to Establish RF Signal for SAR

The following procedures are according to FCC KDB Publication 941225 D01 "SAR Measurement Procedures for 3G Devices" v02, October 2007.

The device was placed into a simulated call using a base station simulator in a RF shielded chamber. Establishing connections in this manner ensure a consistent means for testing SAR and are recommended for evaluating SAR [4]. Devices under test were evaluated prior to testing, with a fully charged battery and were configured to operate at maximum output power. In order to verify that the device was tested throughout the SAR test at maximum output power, the SAR measurement system measures a "point SAR" at an arbitrary reference point at the start and end of the 1 gram SAR evaluation, to assess for any power drifts during the evaluation. If the power drift deviated by more than 5%, the SAR test and drift measurements were repeated.



### 8.3 SAR Measurement Conditions for CDMA2000

The following procedures were performed according to FCC KDB Publication 941225 D01 "SAR Measurement Procedures for 3G Devices" v02, October 2007.

#### 8.3.1 Output Power Verification

See 3GPP2 C.S0011/TIA-98-E as recommended by "SAR Measurement Procedures for 3G Devices" v02, October 2007. Maximum output power is verified on the High, Middle and Low channels according to procedures in section 4.4.5.2 of 3GPP2 C.S0011/TIA-98-E. SO55 tests were measured with power control bits in the "All Up" condition.

1. If the mobile station (MS) supports Reverse TCH RC 1 and Forward TCH RC 1, set up a call using Fundamental Channel Test Mode 1 (RC=1/1) with 9600 bps data rate only.
2. Under RC1, C.S0011 Table 4.4.5.2-1, Table 8-1 parameters were applied.
3. If the MS supports the RC 3 Reverse FCH, RC3 Reverse SCH<sub>0</sub> and demodulation of RC 3,4, or 5, set up a call using Supplemental Channel Test Mode 3 (RC 3/3) with 9600 bps Fundamental Channel and 9600 bps SCH<sub>0</sub> data rate.
4. Under RC3, C.S0011 Table 4.4.5.2-2, Table 8-2 was applied.

FCC ID: V65C6721A1	 <b>PCTEST</b> ENGINEERING LABORATORY, INC.	SAR EVALUATION REPORT	 <b>KYOCERA</b>	Reviewed by: Quality Manager
Document S/N: 0Y1212071742-R4.V65	Test Dates: 12/10/12 - 02/22/13	DUT Type: Portable Handset		Page 15 of 82

**Table 8-1  
Parameters for Max. Power for RC1**

Parameter	Units	Value
$I_{or}$	dBm/1.23 MHz	-104
$\frac{Pilot E_c}{I_{or}}$	dB	-7
$\frac{Traffic E_c}{I_{or}}$	dB	-7.4

**Table 8-2  
Parameters for Max. Power for RC3**

Parameter	Units	Value
$I_{or}$	dBm/1.23 MHz	-86
$\frac{Pilot E_c}{I_{or}}$	dB	-7
$\frac{Traffic E_c}{I_{or}}$	dB	-7.4

5. FCHs were configured at full rate for maximum SAR with “All Up” power control bits.

### 8.3.2 Head SAR Measurements

SAR for head exposure configurations is measured in RC3 with the DUT configured to transmit at full rate using Loopback Service Option SO55. SAR for RC1 is not required when the maximum average output of each channel is less than ¼ dB higher than that measured in RC3. Otherwise, SAR is measured on the maximum output channel in RC1 using the exposure configuration that results in the highest SAR for that channel in RC3.

Head SAR was additionally evaluated using EVDO Rev. A to support compliance for VoIP operations. See Section 8.3.4 for EVDO Rev. A configuration parameters.

### 8.3.3 Body SAR Measurements

SAR for body exposure configurations is measured in RC3 with the DUT configured to transmit at full rate on FCH with all other code channels disabled using TDSO / SO32. SAR for multiple code channels (FCH + SCH<sub>n</sub>) is not required when the maximum average output of each RF channel is less than ¼ dB higher than that measured with FCH only. Otherwise, SAR is measured on the maximum output channel (FCH + SCH<sub>n</sub>) with FCH at full rate and SCH<sub>0</sub> enabled at 9600 bps using the exposure configuration that results in the highest SAR for that channel with FCH only. When multiple code channels are enabled, the DUT output may shift by more than 0.5 dB and lead to higher SAR drifts and SCH dropouts. Body SAR was measured using TDSO / SO32 with power control bits in the “All Up”



Body SAR in RC1 is not required when the maximum average output of each channel is less than ¼ dB higher than that measured in RC3. Otherwise, SAR is measured on the maximum output channel in RC1; with Loopback Service Option SO55, at full rate, using the body exposure configuration that results in the highest SAR for that channel in RC3.

### 8.3.4 Handsets with EVDO

For handsets with Ev-Do capabilities, when the maximum average output of each channel in Rev. 0 is less than ¼ dB higher than that measured in RC3 (1x RTT), body SAR for EV-DO is not required. Otherwise, SAR for Rev. 0 is measured on the maximum output channel at 153.6 kbps using the body exposure configuration that results in the highest SAR for that channel in RC3. SAR for Rev. A is not required when the maximum average output of each channel is less than that measured in Rev. 0 or less than ¼ dB higher than that measured in RC3. Otherwise, SAR is measured on the maximum output channel for Rev. A using a Reverse Data Channel payload size of 4096 bits and a Termination Target of 16 slots defined for Subtype 2 Physical Layer configurations. A Forward Traffic Channel data rate corresponding to the 2-slot version of 307.2 kbps with the ACK Channel transmitting in all slots would be configured in the downlink for both Rev. 0 and Rev. A.

### 8.3.5 Body SAR Measurements for EVDO Hotspot

Hotspot Body SAR is measured using Subtype 0/1 Physical Layer configurations for Rev. 0 per KDB Publication 941225 D01 procedures for “1x Ev-Do data Devices”. SAR for Subtype 2

FCC ID: V65C6721A1	 <b>PCTEST</b> ENGINEERING LABORATORY, INC.	<b>SAR EVALUATION REPORT</b>	 <b>KYOCERA</b>	Reviewed by: Quality Manager
Document S/N: 0Y1212071742-R4.V65	Test Dates: 12/10/12 - 02/22/13	DUT Type: Portable Handset	Page 16 of 82	



Physical layer configurations is not required for Rev. A when the maximum average output of each RF channels is less than that measured in Subtype 0/1 Physical layer configurations. Otherwise, SAR is measured on the maximum output channel for Rev. A using the exposure configuration that results in the highest SAR for the RF channels in Rev. 0. The AT is tested with a Reverse Data Channel rate of 153.6 kbps in Subtype 0/1 Physical Layer configurations; and a Reverse Data Channel payload size of 4096 bits and Termination Target of 16 slots in Subtype 2 Physical Layer configurations.

SAR is not required for 1x RTT for Ev-Do devices that also support 1x RTT voice and/or data operations, when the maximum average output of each channel is less than 1/4 dB higher than that measured in Subtype 0/1 Physical Layer configurations for Rev. 0. Otherwise, CDMA “Body-SAR Measurement” procedures for “CDMA 2000 1x Handsets” were applied.

## 8.4 SAR Measurement Conditions for LTE

LTE modes were tested according to FCC KDB 941225 D05v02 publication. Please see notes after the tabulated SAR data for required test configurations. Establishing connections with base station simulators ensure a consistent means for testing SAR and are recommended for evaluating SAR [4]. The R&S CMW500 was used for LTE output power measurements and SAR testing. Closed loop power control was used so the UE transmits with maximum output power during SAR testing.

### 8.4.1 Spectrum Plots for RB Configurations

A properly configured base station simulator was used for SAR tests and power measurements. Therefore, spectrum plots for RB configurations were not required to be included in this report.

### 8.4.2 MPR

MPR is permanently implemented for this device by the manufacturer. The specific manufacturer target MPR is indicated alongside the SAR results. MPR is enabled for this device, according to 3GPP TS36.101 Section 6.2.3 – 6.2.5 under Table 6.2.3-1.



### 8.4.3 A-MPR

A-MPR (Additional MPR) has been disabled for all SAR tests by setting NS=01 on the base station simulator.

### 8.4.4 Required RB Size and RB Offsets for SAR Testing

According to FCC KDB 941225 D05v02r01:

- a. Per Section 5.2.1, SAR is required for QPSK 1 RB Allocation for the largest bandwidth
  - i. The required channel and offset combination with the highest maximum output power is required for SAR.
  - ii. When the reported SAR is  $\leq 0.8$  W/kg, testing of the remaining RB offset configurations and required test channels is not required. Otherwise, SAR is required for the remaining required test channels using the RB offset configuration with highest output power for that channel.
  - iii. When the reported SAR for a required test channel is  $> 1.45$  W/kg, SAR is required for all RB offset configurations for that channel.
- b. Per Section 5.2.2, SAR is required for 50% RB allocation using the largest bandwidth following the same procedures outlined in Section 5.2.1.
- c. Per Section 5.2.3, QPSK SAR is not required for the 100% allocation when the highest maximum output power for the 100% allocation is less than the highest maximum output power of the 1 RB and 50% RB allocations and the reported SAR for the 1 RB and 50% RB allocations is  $< 0.8$  W/kg.

FCC ID: V65C6721A1	 <b>PCTEST</b> ENGINEERING LABORATORY, INC.	SAR EVALUATION REPORT	 <b>KYOCERA</b>	Reviewed by: Quality Manager
Document S/N: 0Y1212071742-R4.V65	Test Dates: 12/10/12 - 02/22/13	DUT Type: Portable Handset	Page 17 of 82	

- d. Per Section 5.2.4 and 5.3, SAR tests for higher order modulations and lower bandwidths configurations are not required when the conducted power of the required test configurations determined by Sections 5.2.1 through 5.2.3 is less than or equal to ½ dB higher than the equivalent configuration using QPSK modulation and when the QPSK SAR for those configurations is <1.45 W/kg.

## 8.5 SAR Testing with 802.11 Transmitters

Normal network operating configurations are not suitable for measuring the SAR of 802.11 b/g/n transmitters. Unpredictable fluctuations in network traffic and antenna diversity conditions can introduce undesirable variations in SAR results. The SAR for these devices should be measured using chipset based test mode software to ensure the results are consistent and reliable. See KDB Publication 248227 D01v01r02 for more details.



### 8.5.1 General Device Setup

Chipset based test mode software is hardware dependent and generally varies among manufacturers. The device operating parameters established in test mode for SAR measurements must be identical to those programmed in production units, including output power levels, amplifier gain settings and other RF performance tuning parameters. The test frequencies should correspond to actual channel frequencies defined for domestic use. SAR for devices with switched diversity should be measured with only one antenna transmitting at a time during each SAR measurement, according to a fixed modulation and data rate. The same data pattern should be used for all measurements.

### 8.5.2 Frequency Channel Configurations [27]

For 2.4 GHz, the highest average RF output power channel between the low, mid and high channel at the lowest data rate was selected for SAR evaluation in 802.11b mode. 802.11g/n modes and higher data rates for 802.11b were additionally evaluated for SAR if the output power of the respective mode was 0.25 dB or higher than the powers of the SAR configurations tested in the 802.11b mode.

If the maximum extrapolated peak SAR of the zoom scan for the highest output channel was less than 1.6 W/kg or if the 1g averaged SAR was less than 0.8 W/kg, SAR testing was not required for the other test channels in the band.

FCC ID: V65C6721A1	 <b>PCTEST</b> ENGINEERING LABORATORY, INC.	<b>SAR EVALUATION REPORT</b>	 <b>KYOCERA</b>	Reviewed by: Quality Manager
Document S/N: 0Y1212071742-R4.V65	Test Dates: 12/10/12 - 02/22/13	DUT Type: Portable Handset	Page 18 of 82	

# 9 RF CONDUCTED POWERS

## 9.1 CDMA Conducted Powers

Band	Channel	Frequency	SO55 [dBm]	SO55 [dBm]	TDSO SO32 [dBm]	TDSO SO32 [dBm]	1x EvDO Rev. 0 [dBm]	1x EvDO Rev. A [dBm]
	F-RC	MHz	RC1	RC3	FCH+SCH	FCH	(RTAP)	(RETAP)
Cellular	1013	824.7	24.55	24.52	24.60	24.54	24.68	24.65
	384	836.52	24.60	24.60	24.60	24.57	24.68	24.67
	777	848.31	24.46	24.47	24.48	24.48	24.70	24.68
AWS	25	1711.25	23.70	23.75	23.77	23.77	23.86	23.82
	450	1732.5	23.75	23.70	23.76	23.76	23.88	23.84
	875	1753.75	23.91	23.82	23.97	23.92	23.99	23.94
PCS	25	1851.25	23.58	23.70	23.65	23.68	23.73	23.71
	600	1880	23.60	23.89	23.61	23.63	23.82	23.78
	1175	1908.75	23.52	23.79	23.53	23.67	23.91	23.88

Note: RC1 is only applicable for IS-95 compatibility.

Per KDB Publication 941225 D01v02:

1. Head SAR was tested with SO55 RC3. SO55 RC1 was not required since the average output power was not more than 0.25 dB than the SO55 RC3 powers.
2. Body-Worn SAR was tested with 1x RTT with TDSO / SO32 FCH Only. Ev-Do and TDSO / SO32 FCH+SCH SAR tests were not required since the average output power was not more than 0.25 dB higher than the TDSO / SO32 FCH only powers.
3. Hotspot SAR is measured using Subtype 0/1 Physical Layer configurations for Rev. 0. If the average output power of Subtype 2 for Rev. A is less than the Rev. 0 power levels, then Rev. A SAR is not required. Otherwise, SAR is measured on the maximum output channel for Rev. A using the exposure configuration that results in the highest SAR for that RF channel in Rev. 0. SAR is not required for 1x RTT for Ev-Do hotspot devices when the maximum average output of each channel is less than 1/4 dB higher than that measured in Subtype 0/1 Physical Layer configurations for Rev. 0
4. CDMA 1x-RTT SAR was additionally required to be evaluated for Hotspot exposure conditions to support simultaneous transmission capabilities.
5. Head SAR was additionally evaluated with EVDO Rev. A to determine compliance for held-to-ear VoIP operations.

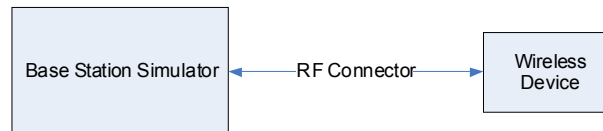

**Figure 9-1**  
Power Measurement Setup

FCC ID: V65C6721A1	PCTEST ENGINEERING LABORATORY, INC.	SAR EVALUATION REPORT	KYOCERA	Reviewed by: Quality Manager
Document S/N: 0Y1212071742-R4.V65	Test Dates: 12/10/12 - 02/22/13	DUT Type: Portable Handset		Page 19 of 82

## 9.2 LTE Conducted Powers

### 9.2.1 LTE Band 12

**Table 9-1**  
**LTE Band 12 Conducted Powers - 10 MHz Bandwidth**

Frequency [MHz]	Channel	Bandwidth [MHz]	Modulation	RB Size	RB Offset	Conducted Power [dBm]	Target MPR [dB]	MPR Allowed per 3GPP [dB]
707.5	23095	10	QPSK	1	0	23.30	0	0
707.5	23095	10	QPSK	1	25	23.18	0	0
707.5	23095	10	QPSK	1	49	23.08	0	0
707.5	23095	10	QPSK	25	0	22.00	1	0-1
707.5	23095	10	QPSK	25	12	22.09	1	0-1
707.5	23095	10	QPSK	25	25	21.99	1	0-1
707.5	23095	10	QPSK	50	0	21.97	1	0-1
707.5	23095	10	16QAM	1	0	22.13	1	0-1
707.5	23095	10	16QAM	1	25	22.27	1	0-1
707.5	23095	10	16QAM	1	49	22.19	1	0-1
707.5	23095	10	16QAM	25	0	20.95	2	0-2
707.5	23095	10	16QAM	25	12	21.01	2	0-2
707.5	23095	10	16QAM	25	25	20.95	2	0-2
707.5	23095	10	16QAM	50	0	20.88	2	0-2

Note: LTE Band 12 at 10 MHz Bandwidth does not support three non-overlapping channels. Per KDB 941225 D05v02, when a device supports overlapping channel assignment in a channel bandwidth configuration, the mid channel of the group of overlapping channels should be selected for testing

**Table 9-2**  
**LTE Band 12 Conducted Powers - 5 MHz Bandwidth**

Frequency [MHz]	Channel	Bandwidth [MHz]	Modulation	RB Size	RB Offset	Conducted Power [dBm]	Target MPR [dB]	MPR Allowed per 3GPP [dB]
701.5	23035	5	QPSK	1	0	22.74	0	0
701.5	23035	5	QPSK	1	12	22.79	0	0
701.5	23035	5	QPSK	1	24	23.15	0	0
701.5	23035	5	QPSK	12	0	21.63	1	0-1
701.5	23035	5	QPSK	12	6	21.66	1	0-1
701.5	23035	5	QPSK	12	13	21.76	1	0-1
701.5	23035	5	QPSK	25	0	21.54	1	0-1
701.5	23035	5	16-QAM	1	0	21.93	1	0-1
701.5	23035	5	16-QAM	1	12	21.84	1	0-1
701.5	23035	5	16-QAM	1	24	22.13	1	0-1
701.5	23035	5	16-QAM	12	0	20.64	2	0-2
701.5	23035	5	16-QAM	12	6	20.64	2	0-2
701.5	23035	5	16-QAM	12	13	20.98	2	0-2
701.5	23035	5	16-QAM	25	0	20.65	2	0-2
707.5	23095	5	QPSK	1	0	22.90	0	0
707.5	23095	5	QPSK	1	12	23.02	0	0
707.5	23095	5	QPSK	1	24	22.86	0	0
707.5	23095	5	QPSK	12	0	22.02	1	0-1
707.5	23095	5	QPSK	12	6	21.87	1	0-1
707.5	23095	5	QPSK	12	13	21.88	1	0-1
707.5	23095	5	QPSK	25	0	21.83	1	0-1
707.5	23095	5	16-QAM	1	0	21.97	1	0-1
707.5	23095	5	16-QAM	1	12	22.12	1	0-1
707.5	23095	5	16-QAM	1	24	22.02	1	0-1
707.5	23095	5	16-QAM	12	0	21.02	2	0-2
707.5	23095	5	16-QAM	12	6	21.01	2	0-2
707.5	23095	5	16-QAM	12	13	20.89	2	0-2
707.5	23095	5	16-QAM	25	0	20.88	2	0-2
713.5	23155	5	QPSK	1	0	22.79	0	0
713.5	23155	5	QPSK	1	12	23.02	0	0
713.5	23155	5	QPSK	1	24	22.98	0	0
713.5	23155	5	QPSK	12	0	21.75	1	0-1
713.5	23155	5	QPSK	12	6	21.73	1	0-1
713.5	23155	5	QPSK	12	13	21.89	1	0-1
713.5	23155	5	QPSK	25	0	21.65	1	0-1
713.5	23155	5	16-QAM	1	0	21.91	1	0-1
713.5	23155	5	16-QAM	1	12	22.02	1	0-1
713.5	23155	5	16-QAM	1	24	22.03	1	0-1
713.5	23155	5	16-QAM	12	0	20.88	2	0-2
713.5	23155	5	16-QAM	12	6	20.87	2	0-2
713.5	23155	5	16-QAM	12	13	20.90	2	0-2
713.5	23155	5	16-QAM	25	0	20.71	2	0-2

**Table 9-3  
LTE Band 12 Conducted Powers - 3 MHz Bandwidth**

Frequency [MHz]	Channel	Bandwidth [MHz]	Modulation	RB Size	RB Offset	Conducted Power [dBm]	Target MPR [dB]	MPR Allowed per 3GPP [dB]
700.5	23025	3	QPSK	1	0	22.76	0	0
700.5	23025	3	QPSK	1	7	22.72	0	0
700.5	23025	3	QPSK	1	14	23.08	0	0
700.5	23025	3	QPSK	8	0	21.71	1	0-1
700.5	23025	3	QPSK	8	4	21.70	1	0-1
700.5	23025	3	QPSK	8	7	21.77	1	0-1
700.5	23025	3	QPSK	15	0	21.61	1	0-1
700.5	23025	3	16-QAM	1	0	21.82	1	0-1
700.5	23025	3	16-QAM	1	7	21.53	1	0-1
700.5	23025	3	16-QAM	1	14	21.95	1	0-1
700.5	23025	3	16-QAM	8	0	20.63	2	0-2
700.5	23025	3	16-QAM	8	4	20.60	2	0-2
700.5	23025	3	16-QAM	8	7	20.83	2	0-2
700.5	23025	3	16-QAM	15	0	20.76	2	0-2
707.5	23095	3	QPSK	1	0	23.21	0	0
707.5	23095	3	QPSK	1	7	22.94	0	0
707.5	23095	3	QPSK	1	14	23.01	0	0
707.5	23095	3	QPSK	8	0	21.96	1	0-1
707.5	23095	3	QPSK	8	4	21.86	1	0-1
707.5	23095	3	QPSK	8	7	21.86	1	0-1
707.5	23095	3	QPSK	15	0	21.85	1	0-1
707.5	23095	3	16-QAM	1	0	22.25	1	0-1
707.5	23095	3	16-QAM	1	7	21.61	1	0-1
707.5	23095	3	16-QAM	1	14	22.16	1	0-1
707.5	23095	3	16-QAM	8	0	20.94	2	0-2
707.5	23095	3	16-QAM	8	4	20.92	2	0-2
707.5	23095	3	16-QAM	8	7	20.87	2	0-2
707.5	23095	3	16-QAM	15	0	20.93	2	0-2
714.5	23165	3	QPSK	1	0	22.82	0	0
714.5	23165	3	QPSK	1	7	22.87	0	0
714.5	23165	3	QPSK	1	14	22.99	0	0
714.5	23165	3	QPSK	8	0	21.73	1	0-1
714.5	23165	3	QPSK	8	4	21.79	1	0-1
714.5	23165	3	QPSK	8	7	21.86	1	0-1
714.5	23165	3	QPSK	15	0	21.65	1	0-1
714.5	23165	3	16-QAM	1	0	21.80	1	0-1
714.5	23165	3	16-QAM	1	7	21.78	1	0-1
714.5	23165	3	16-QAM	1	14	22.08	1	0-1
714.5	23165	3	16-QAM	8	0	20.80	2	0-2
714.5	23165	3	16-QAM	8	4	20.77	2	0-2
714.5	23165	3	16-QAM	8	7	20.66	2	0-2
714.5	23165	3	16-QAM	15	0	20.82	2	0-2

**Table 9-4  
LTE Band 12 Conducted Powers -1.4 MHz Bandwidth**

Frequency [MHz]	Channel	Bandwidth [MHz]	Modulation	RB Size	RB Offset	Conducted Power [dBm]	Target MPR [dB]	MPR Allowed per 3GPP [dB]
699.7	23017	1.4	QPSK	1	0	22.83	0	0
699.7	23017	1.4	QPSK	1	2	22.86	0	0
699.7	23017	1.4	QPSK	1	5	22.88	0	0
699.7	23017	1.4	QPSK	3	0	22.92	0	0
699.7	23017	1.4	QPSK	3	2	22.93	0	0
699.7	23017	1.4	QPSK	3	3	22.91	0	0
699.7	23017	1.4	QPSK	6	0	21.95	1	0-1
699.7	23017	1.4	16-QAM	1	0	21.63	1	0-1
699.7	23017	1.4	16-QAM	1	2	21.64	1	0-1
699.7	23017	1.4	16-QAM	1	5	21.77	1	0-1
699.7	23017	1.4	16-QAM	3	0	21.97	1	0-1
699.7	23017	1.4	16-QAM	3	2	21.94	1	0-1
699.7	23017	1.4	16-QAM	3	3	21.98	1	0-1
699.7	23017	1.4	16-QAM	6	0	20.91	2	0-2
707.5	23095	1.4	QPSK	1	0	23.09	0	0
707.5	23095	1.4	QPSK	1	2	23.08	0	0
707.5	23095	1.4	QPSK	1	5	23.03	0	0
707.5	23095	1.4	QPSK	3	0	22.98	0	0
707.5	23095	1.4	QPSK	3	2	23.08	0	0
707.5	23095	1.4	QPSK	3	3	22.98	0	0
707.5	23095	1.4	QPSK	6	0	21.99	1	0-1
707.5	23095	1.4	16-QAM	1	0	22.19	1	0-1
707.5	23095	1.4	16-QAM	1	2	22.10	1	0-1
707.5	23095	1.4	16-QAM	1	5	22.11	1	0-1
707.5	23095	1.4	16-QAM	3	0	21.98	1	0-1
707.5	23095	1.4	16-QAM	3	2	21.99	1	0-1
707.5	23095	1.4	16-QAM	3	3	22.00	1	0-1
707.5	23095	1.4	16-QAM	6	0	20.93	2	0-2
715.3	23173	1.4	QPSK	1	0	23.22	0	0
715.3	23173	1.4	QPSK	1	2	23.09	0	0
715.3	23173	1.4	QPSK	1	5	23.12	0	0
715.3	23173	1.4	QPSK	3	0	22.89	0	0
715.3	23173	1.4	QPSK	3	2	23.24	0	0
715.3	23173	1.4	QPSK	3	3	23.22	0	0
715.3	23173	1.4	QPSK	6	0	21.97	1	0-1
715.3	23173	1.4	16-QAM	1	0	22.06	1	0-1
715.3	23173	1.4	16-QAM	1	2	22.03	1	0-1
715.3	23173	1.4	16-QAM	1	5	22.07	1	0-1
715.3	23173	1.4	16-QAM	3	0	21.79	1	0-1
715.3	23173	1.4	16-QAM	3	2	21.89	1	0-1
715.3	23173	1.4	16-QAM	3	3	21.86	1	0-1
715.3	23173	1.4	16-QAM	6	0	20.96	2	0-2

## 9.2.2

## LTE Band 17

Table 9-5

LTE Band 17 Conducted Powers - 10 MHz Bandwidth

Frequency [MHz]	Channel	Bandwidth [MHz]	Modulation	RB Size	RB Offset	Conducted Power [dBm]	Target MPR [dB]	MPR Allowed per 3GPP [dB]
710.0	23790	10	QPSK	1	0	23.39	0	0
710.0	23790	10	QPSK	1	25	23.12	0	0
710.0	23790	10	QPSK	1	49	23.30	0	0
710.0	23790	10	QPSK	25	0	22.24	1	0-1
710.0	23790	10	QPSK	25	12	22.13	1	0-1
710.0	23790	10	QPSK	25	25	22.21	1	0-1
710.0	23790	10	QPSK	50	0	22.00	1	0-1
710.0	23790	10	16QAM	1	0	22.45	1	0-1
710.0	23790	10	16QAM	1	25	22.20	1	0-1
710.0	23790	10	16QAM	1	49	22.44	1	0-1
710.0	23790	10	16QAM	25	0	21.22	2	0-2
710.0	23790	10	16QAM	25	12	21.12	2	0-2
710.0	23790	10	16QAM	25	25	21.06	2	0-2
710.0	23790	10	16QAM	50	0	21.08	2	0-2

Note: LTE Band 17 at 10 MHz Bandwidth does not support three non-overlapping channels. Per KDB 941225 D05v02, when a device supports overlapping channel assignment in a channel bandwidth configuration, the mid channel of the group of overlapping channels should be selected for testing

Table 9-6

LTE Band 17 Conducted Powers - 5 MHz Bandwidth

Frequency [MHz]	Channel	Bandwidth [MHz]	Modulation	RB Size	RB Offset	Conducted Power [dBm]	Target MPR [dB]	MPR Allowed per 3GPP [dB]
710.0	23790	5	QPSK	1	0	23.44	0	0
710.0	23790	5	QPSK	1	12	23.23	0	0
710.0	23790	5	QPSK	1	24	23.16	0	0
710.0	23790	5	QPSK	12	0	22.24	1	0-1
710.0	23790	5	QPSK	12	6	22.27	1	0-1
710.0	23790	5	QPSK	12	13	22.34	1	0-1
710.0	23790	5	QPSK	25	0	22.15	1	0-1
710.0	23790	5	16-QAM	1	0	22.46	1	0-1
710.0	23790	5	16-QAM	1	12	22.34	1	0-1
710.0	23790	5	16-QAM	1	24	22.32	1	0-1
710.0	23790	5	16-QAM	12	0	21.36	2	0-2
710.0	23790	5	16-QAM	12	6	21.26	2	0-2
710.0	23790	5	16-QAM	12	13	21.40	2	0-2
710.0	23790	5	16-QAM	25	0	21.14	2	0-2

Note: LTE Band 17 at 5 MHz Bandwidth does not support three non-overlapping channels. Per KDB 941225 D05v02, when a device supports overlapping channel assignment in a channel bandwidth configuration, the mid channel of the group of overlapping channels should be selected for testing

## 9.2.3



## LTE Band 5 (Cell)

Table 9-7

LTE Band 5 (Cell) Conducted Powers - 10 MHz Bandwidth

Frequency [MHz]	Channel	Bandwidth [MHz]	Modulation	RB Size	RB Offset	Conducted Power [dBm]	Target MPR [dB]	MPR Allowed per 3GPP [dB]
836.5	20525	10	QPSK	1	0	23.32	0	0
836.5	20525	10	QPSK	1	25	23.38	0	0
836.5	20525	10	QPSK	1	49	23.47	0	0
836.5	20525	10	QPSK	25	0	22.32	1	0-1
836.5	20525	10	QPSK	25	12	22.44	1	0-1
836.5	20525	10	QPSK	25	25	22.39	1	0-1
836.5	20525	10	QPSK	50	0	22.35	1	0-1
836.5	20525	10	16QAM	1	0	22.32	1	0-1
836.5	20525	10	16QAM	1	25	22.49	1	0-1
836.5	20525	10	16QAM	1	49	22.08	1	0-1
836.5	20525	10	16QAM	25	0	21.30	2	0-2
836.5	20525	10	16QAM	25	12	21.31	2	0-2
836.5	20525	10	16QAM	25	25	21.48	2	0-2
836.5	20525	10	16QAM	50	0	21.30	2	0-2

Note: LTE Band 5 at 10 MHz Bandwidth does not support three non-overlapping channels. Per KDB 941225 D05v02, when a device supports overlapping channel assignment in a channel bandwidth configuration, the mid channel of the group of overlapping channels should be selected for testing

FCC ID: V65C6721A1	 PCTEST ENGINEERING LABORATORY, INC.	SAR EVALUATION REPORT	 KYOCERA	Reviewed by: Quality Manager
Document S/N: 0Y1212071742-R4.V65	Test Dates: 12/10/12 - 02/22/13	DUT Type: Portable Handset	Page 22 of 82	

**Table 9-8**  
**LTE Band 5 (Cell) Conducted Powers - 5 MHz Bandwidth**

Frequency [MHz]	Channel	Bandwidth [MHz]	Modulation	RB Size	RB Offset	Conducted Power [dBm]	Target MPR [dB]	MPR Allowed per 3GPP [dB]
826.5	20425	5	QPSK	1	0	22.33	0	0
826.5	20425	5	QPSK	1	12	23.16	0	0
826.5	20425	5	QPSK	1	24	23.25	0	0
826.5	20425	5	QPSK	12	0	22.24	1	0-1
826.5	20425	5	QPSK	12	6	22.08	1	0-1
826.5	20425	5	QPSK	12	13	22.17	1	0-1
826.5	20425	5	QPSK	25	0	22.06	1	0-1
826.5	20425	5	16-QAM	1	0	22.29	1	0-1
826.5	20425	5	16-QAM	1	12	22.31	1	0-1
826.5	20425	5	16-QAM	1	24	22.45	1	0-1
826.5	20425	5	16-QAM	12	0	21.30	2	0-2
826.5	20425	5	16-QAM	12	6	21.24	2	0-2
826.5	20425	5	16-QAM	12	13	21.27	2	0-2
826.5	20425	5	16-QAM	25	0	21.05	2	0-2
836.5	20525	5	QPSK	1	0	23.27	0	0
836.5	20525	5	QPSK	1	12	23.45	0	0
836.5	20525	5	QPSK	1	24	23.33	0	0
836.5	20525	5	QPSK	12	0	22.35	1	0-1
836.5	20525	5	QPSK	12	6	22.28	1	0-1
836.5	20525	5	QPSK	12	13	22.24	1	0-1
836.5	20525	5	QPSK	25	0	22.23	1	0-1
836.5	20525	5	16-QAM	1	0	22.08	1	0-1
836.5	20525	5	16-QAM	1	12	22.15	1	0-1
836.5	20525	5	16-QAM	1	24	22.45	1	0-1
836.5	20525	5	16-QAM	12	0	21.32	2	0-2
836.5	20525	5	16-QAM	12	6	21.46	2	0-2
836.5	20525	5	16-QAM	12	13	21.42	2	0-2
836.5	20525	5	16-QAM	25	0	21.30	2	0-2
846.5	20625	5	QPSK	1	0	23.10	0	0
846.5	20625	5	QPSK	1	12	22.90	0	0
846.5	20625	5	QPSK	1	24	22.95	0	0
846.5	20625	5	QPSK	12	0	22.35	1	0-1
846.5	20625	5	QPSK	12	6	21.91	1	0-1
846.5	20625	5	QPSK	12	13	22.04	1	0-1
846.5	20625	5	QPSK	25	0	22.15	1	0-1
846.5	20625	5	16-QAM	1	0	22.29	1	0-1
846.5	20625	5	16-QAM	1	12	22.06	1	0-1
846.5	20625	5	16-QAM	1	24	22.27	1	0-1
846.5	20625	5	16-QAM	12	0	21.30	2	0-2
846.5	20625	5	16-QAM	12	6	21.44	2	0-2
846.5	20625	5	16-QAM	12	13	21.21	2	0-2
846.5	20625	5	16-QAM	25	0	21.13	2	0-2

**Table 9-9**  
**LTE Band 5 (Cell) Conducted Powers - 3 MHz Bandwidth**

Frequency [MHz]	Channel	Bandwidth [MHz]	Modulation	RB Size	RB Offset	Conducted Power [dBm]	Target MPR [dB]	MPR Allowed per 3GPP [dB]
825.5	20415	3	QPSK	1	0	23.45	0	0
825.5	20415	3	QPSK	1	7	23.19	0	0
825.5	20415	3	QPSK	1	14	23.35	0	0
825.5	20415	3	QPSK	8	0	22.21	1	0-1
825.5	20415	3	QPSK	8	4	22.17	1	0-1
825.5	20415	3	QPSK	8	7	22.15	1	0-1
825.5	20415	3	QPSK	15	0	22.30	1	0-1
825.5	20415	3	16-QAM	1	0	22.29	1	0-1
825.5	20415	3	16-QAM	1	7	22.34	1	0-1
825.5	20415	3	16-QAM	1	14	21.94	1	0-1
825.5	20415	3	16-QAM	8	0	21.13	2	0-2
825.5	20415	3	16-QAM	8	4	21.09	2	0-2
825.5	20415	3	16-QAM	8	7	21.11	2	0-2
825.5	20415	3	16-QAM	15	0	21.28	2	0-2
836.5	20525	3	QPSK	1	0	23.28	0	0
836.5	20525	3	QPSK	1	7	23.23	0	0
836.5	20525	3	QPSK	1	14	23.33	0	0
836.5	20525	3	QPSK	8	0	22.27	1	0-1
836.5	20525	3	QPSK	8	4	22.17	1	0-1
836.5	20525	3	QPSK	8	7	22.16	1	0-1
836.5	20525	3	QPSK	15	0	22.23	1	0-1
836.5	20525	3	16-QAM	1	0	22.11	1	0-1
836.5	20525	3	16-QAM	1	7	22.25	1	0-1
836.5	20525	3	16-QAM	1	14	22.42	1	0-1
836.5	20525	3	16-QAM	8	0	21.12	2	0-2
836.5	20525	3	16-QAM	8	4	21.06	2	0-2
836.5	20525	3	16-QAM	8	7	21.15	2	0-2
836.5	20525	3	16-QAM	15	0	21.32	2	0-2
847.5	20635	3	QPSK	1	0	23.00	0	0
847.5	20635	3	QPSK	1	7	23.14	0	0
847.5	20635	3	QPSK	1	14	23.15	0	0
847.5	20635	3	QPSK	8	0	22.11	1	0-1
847.5	20635	3	QPSK	8	4	22.11	1	0-1
847.5	20635	3	QPSK	8	7	22.02	1	0-1
847.5	20635	3	QPSK	15	0	21.98	1	0-1
847.5	20635	3	16-QAM	1	0	22.22	1	0-1
847.5	20635	3	16-QAM	1	7	22.36	1	0-1
847.5	20635	3	16-QAM	1	14	22.00	1	0-1
847.5	20635	3	16-QAM	8	0	21.29	2	0-2
847.5	20635	3	16-QAM	8	4	21.11	2	0-2
847.5	20635	3	16-QAM	8	7	20.92	2	0-2
847.5	20635	3	16-QAM	15	0	21.09	2	0-2

**Table 9-10  
LTE Band 5 (Cell) Conducted Powers -1.4 MHz Bandwidth**

Frequency [MHz]	Channel	Bandwidth [MHz]	Modulation	RB Size	RB Offset	Conducted Power [dBm]	Target MPR [dB]	MPR Allowed per 3GPP [dB]
824.7	20407	1.4	QPSK	1	0	23.31	0	0
824.7	20407	1.4	QPSK	1	2	23.29	0	0
824.7	20407	1.4	QPSK	1	5	23.24	0	0
824.7	20407	1.4	QPSK	3	0	23.27	0	0
824.7	20407	1.4	QPSK	3	2	23.31	0	0
824.7	20407	1.4	QPSK	3	3	23.26	0	0
824.7	20407	1.4	QPSK	6	0	22.30	1	0-1
824.7	20407	1.4	16-QAM	1	0	22.11	1	0-1
824.7	20407	1.4	16-QAM	1	2	22.15	1	0-1
824.7	20407	1.4	16-QAM	1	5	22.11	1	0-1
824.7	20407	1.4	16-QAM	3	0	22.46	1	0-1
824.7	20407	1.4	16-QAM	3	2	22.41	1	0-1
824.7	20407	1.4	16-QAM	3	3	22.38	1	0-1
824.7	20407	1.4	16-QAM	6	0	21.22	2	0-2
836.5	20525	1.4	QPSK	1	0	23.32	0	0
836.5	20525	1.4	QPSK	1	2	23.37	0	0
836.5	20525	1.4	QPSK	1	5	23.34	0	0
836.5	20525	1.4	QPSK	3	0	23.34	0	0
836.5	20525	1.4	QPSK	3	2	23.33	0	0
836.5	20525	1.4	QPSK	3	3	23.44	0	0
836.5	20525	1.4	QPSK	6	0	22.44	1	0-1
836.5	20525	1.4	16-QAM	1	0	22.44	1	0-1
836.5	20525	1.4	16-QAM	1	2	22.41	1	0-1
836.5	20525	1.4	16-QAM	1	5	22.43	1	0-1
836.5	20525	1.4	16-QAM	3	0	22.24	1	0-1
836.5	20525	1.4	16-QAM	3	2	22.30	1	0-1
836.5	20525	1.4	16-QAM	3	3	22.26	1	0-1
836.5	20525	1.4	16-QAM	6	0	21.39	2	0-2
848.3	20643	1.4	QPSK	1	0	23.27	0	0
848.3	20643	1.4	QPSK	1	2	23.18	0	0
848.3	20643	1.4	QPSK	1	5	23.24	0	0
848.3	20643	1.4	QPSK	3	0	23.22	0	0
848.3	20643	1.4	QPSK	3	2	23.07	0	0
848.3	20643	1.4	QPSK	3	3	23.24	0	0
848.3	20643	1.4	QPSK	6	0	22.25	1	0-1
848.3	20643	1.4	16-QAM	1	0	22.43	1	0-1
848.3	20643	1.4	16-QAM	1	2	22.38	1	0-1
848.3	20643	1.4	16-QAM	1	5	22.34	1	0-1
848.3	20643	1.4	16-QAM	3	0	22.13	1	0-1
848.3	20643	1.4	16-QAM	3	2	22.09	1	0-1
848.3	20643	1.4	16-QAM	3	3	22.08	1	0-1
848.3	20643	1.4	16-QAM	6	0	21.22	2	0-2

**9.2.4 LTE Band 4 (AWS)**

**Table 9-11  
LTE Band 4 (AWS) Conducted Powers - 10 MHz Bandwidth**

Frequency [MHz]	Channel	Bandwidth [MHz]	Modulation	RB Size	RB Offset	Conducted Power [dBm]	Target MPR [dB]	MPR Allowed per 3GPP [dB]
1715	20000	10	QPSK	1	0	22.76	0	0
1715	20000	10	QPSK	1	25	22.70	0	0
1715	20000	10	QPSK	1	49	22.65	0	0
1715	20000	10	QPSK	25	0	21.60	1	0-1
1715	20000	10	QPSK	25	12	21.75	1	0-1
1715	20000	10	QPSK	25	25	21.64	1	0-1
1715	20000	10	QPSK	50	0	21.51	1	0-1
1715	20000	10	16QAM	1	0	21.83	1	0-1
1715	20000	10	16QAM	1	25	21.92	1	0-1
1715	20000	10	16QAM	1	49	21.46	1	0-1
1715	20000	10	16QAM	25	0	20.68	2	0-2
1715	20000	10	16QAM	25	12	20.76	2	0-2
1715	20000	10	16QAM	25	25	20.73	2	0-2
1715	20000	10	16QAM	50	0	20.65	2	0-2
1732.5	20175	10	QPSK	1	0	22.63	0	0
1732.5	20175	10	QPSK	1	25	22.65	0	0
1732.5	20175	10	QPSK	1	49	22.38	0	0
1732.5	20175	10	QPSK	25	0	21.64	1	0-1
1732.5	20175	10	QPSK	25	12	21.49	1	0-1
1732.5	20175	10	QPSK	25	25	21.22	1	0-1
1732.5	20175	10	QPSK	50	0	21.38	1	0-1
1732.5	20175	10	16QAM	1	0	21.65	1	0-1
1732.5	20175	10	16QAM	1	25	21.71	1	0-1
1732.5	20175	10	16QAM	1	49	21.47	1	0-1
1732.5	20175	10	16QAM	25	0	20.69	2	0-2
1732.5	20175	10	16QAM	25	12	20.53	2	0-2
1732.5	20175	10	16QAM	25	25	20.39	2	0-2
1732.5	20175	10	16QAM	50	0	20.36	2	0-2
1750	20350	10	QPSK	1	0	22.63	0	0
1750	20350	10	QPSK	1	25	22.47	0	0
1750	20350	10	QPSK	1	49	22.31	0	0
1750	20350	10	QPSK	25	0	21.60	1	0-1
1750	20350	10	QPSK	25	12	21.26	1	0-1
1750	20350	10	QPSK	25	25	21.26	1	0-1
1750	20350	10	QPSK	50	0	21.41	1	0-1
1750	20350	10	16QAM	1	0	21.74	1	0-1
1750	20350	10	16QAM	1	25	21.47	1	0-1
1750	20350	10	16QAM	1	49	21.10	1	0-1
1750	20350	10	16QAM	25	0	20.58	2	0-2
1750	20350	10	16QAM	25	12	20.52	2	0-2
1750	20350	10	16QAM	25	25	20.44	2	0-2
1750	20350	10	16QAM	50	0	20.35	2	0-2



**Table 9-12**  
**LTE Band 4 (AWS) Conducted Powers - 5 MHz Bandwidth**

Frequency [MHz]	Channel	Bandwidth [MHz]	Modulation	RB Size	RB Offset	Conducted Power [dBm]	Target MPR [dB]	MPR Allowed per 3GPP [dB]
1712.5	19975	5	QPSK	1	0	22.82	0	0
1712.5	19975	5	QPSK	1	12	22.73	0	0
1712.5	19975	5	QPSK	1	24	22.73	0	0
1712.5	19975	5	QPSK	12	0	21.69	1	0-1
1712.5	19975	5	QPSK	12	6	21.73	1	0-1
1712.5	19975	5	QPSK	12	13	21.68	1	0-1
1712.5	19975	5	QPSK	25	0	21.64	1	0-1
1712.5	19975	5	16-QAM	1	0	21.99	1	0-1
1712.5	19975	5	16-QAM	1	12	21.92	1	0-1
1712.5	19975	5	16-QAM	1	24	21.80	1	0-1
1712.5	19975	5	16-QAM	12	0	20.84	2	0-2
1712.5	19975	5	16-QAM	12	6	20.78	2	0-2
1712.5	19975	5	16-QAM	12	13	20.83	2	0-2
1712.5	19975	5	16-QAM	25	0	20.70	2	0-2
1732.5	20175	5	QPSK	1	0	22.84	0	0
1732.5	20175	5	QPSK	1	12	22.66	0	0
1732.5	20175	5	QPSK	1	24	22.63	0	0
1732.5	20175	5	QPSK	12	0	21.71	1	0-1
1732.5	20175	5	QPSK	12	6	21.61	1	0-1
1732.5	20175	5	QPSK	12	13	21.73	1	0-1
1732.5	20175	5	QPSK	25	0	21.57	1	0-1
1732.5	20175	5	16-QAM	1	0	21.91	1	0-1
1732.5	20175	5	16-QAM	1	12	21.25	1	0-1
1732.5	20175	5	16-QAM	1	24	21.84	1	0-1
1732.5	20175	5	16-QAM	12	0	20.74	2	0-2
1732.5	20175	5	16-QAM	12	6	20.66	2	0-2
1732.5	20175	5	16-QAM	12	13	20.85	2	0-2
1732.5	20175	5	16-QAM	25	0	20.63	2	0-2
1752.5	20375	5	QPSK	1	0	22.50	0	0
1752.5	20375	5	QPSK	1	12	22.35	0	0
1752.5	20375	5	QPSK	1	24	22.37	0	0
1752.5	20375	5	QPSK	12	0	21.35	1	0-1
1752.5	20375	5	QPSK	12	6	21.34	1	0-1
1752.5	20375	5	QPSK	12	13	21.39	1	0-1
1752.5	20375	5	QPSK	25	0	21.27	1	0-1
1752.5	20375	5	16-QAM	1	0	21.73	1	0-1
1752.5	20375	5	16-QAM	1	12	21.33	1	0-1
1752.5	20375	5	16-QAM	1	24	21.48	1	0-1
1752.5	20375	5	16-QAM	12	0	20.55	2	0-2
1752.5	20375	5	16-QAM	12	6	20.50	2	0-2
1752.5	20375	5	16-QAM	12	13	20.42	2	0-2
1752.5	20375	5	16-QAM	25	0	20.37	2	0-2

**Table 9-13**  
**LTE Band 4 (AWS) Conducted Powers - 3 MHz Bandwidth**

Frequency [MHz]	Channel	Bandwidth [MHz]	Modulation	RB Size	RB Offset	Conducted Power [dBm]	Target MPR [dB]	MPR Allowed per 3GPP [dB]
1711.5	19665	3	QPSK	1	0	22.93	0	0
1711.5	19665	3	QPSK	1	7	22.85	0	0
1711.5	19665	3	QPSK	1	14	22.86	0	0
1711.5	19665	3	QPSK	8	0	21.98	1	0-1
1711.5	19665	3	QPSK	8	4	21.78	1	0-1
1711.5	19665	3	QPSK	8	7	21.82	1	0-1
1711.5	19665	3	QPSK	15	0	21.81	1	0-1
1711.5	19665	3	16-QAM	1	0	22.00	1	0-1
1711.5	19665	3	16-QAM	1	7	21.99	1	0-1
1711.5	19665	3	16-QAM	1	14	21.97	1	0-1
1711.5	19665	3	16-QAM	8	0	20.90	2	0-2
1711.5	19665	3	16-QAM	8	4	20.72	2	0-2
1711.5	19665	3	16-QAM	8	7	20.84	2	0-2
1711.5	19665	3	16-QAM	15	0	20.72	2	0-2
1732.5	20175	3	QPSK	1	0	22.97	0	0
1732.5	20175	3	QPSK	1	7	22.76	0	0
1732.5	20175	3	QPSK	1	14	22.96	0	0
1732.5	20175	3	QPSK	8	0	21.89	1	0-1
1732.5	20175	3	QPSK	8	4	21.91	1	0-1
1732.5	20175	3	QPSK	8	7	21.88	1	0-1
1732.5	20175	3	QPSK	15	0	21.80	1	0-1
1732.5	20175	3	16-QAM	1	0	22.00	1	0-1
1732.5	20175	3	16-QAM	1	7	21.84	1	0-1
1732.5	20175	3	16-QAM	1	14	21.90	1	0-1
1732.5	20175	3	16-QAM	8	0	20.86	2	0-2
1732.5	20175	3	16-QAM	8	4	20.67	2	0-2
1732.5	20175	3	16-QAM	8	7	20.63	2	0-2
1732.5	20175	3	16-QAM	15	0	20.82	2	0-2
1753.5	20385	3	QPSK	1	0	22.58	0	0
1753.5	20385	3	QPSK	1	7	22.60	0	0
1753.5	20385	3	QPSK	1	14	22.53	0	0
1753.5	20385	3	QPSK	8	0	21.54	1	0-1
1753.5	20385	3	QPSK	8	4	21.55	1	0-1
1753.5	20385	3	QPSK	8	7	21.52	1	0-1
1753.5	20385	3	QPSK	15	0	21.49	1	0-1
1753.5	20385	3	16-QAM	1	0	21.46	1	0-1
1753.5	20385	3	16-QAM	1	7	21.32	1	0-1
1753.5	20385	3	16-QAM	1	14	21.25	1	0-1
1753.5	20385	3	16-QAM	8	0	20.54	2	0-2
1753.5	20385	3	16-QAM	8	4	20.47	2	0-2
1753.5	20385	3	16-QAM	8	7	20.54	2	0-2
1753.5	20385	3	16-QAM	15	0	20.69	2	0-2

**Table 9-14**  
**LTE Band 4 (AWS) Conducted Powers -1.4 MHz Bandwidth**

Frequency [MHz]	Channel	Bandwidth [MHz]	Modulation	RB Size	RB Offset	Conducted Power [dBm]	Target MPR [dB]	MPR Allowed per 3GPP [dB]
1710.7	19957	1.4	QPSK	1	0	22.88	0	0
1710.7	19957	1.4	QPSK	1	2	22.87	0	0
1710.7	19957	1.4	QPSK	1	5	22.83	0	0
1710.7	19957	1.4	QPSK	3	0	22.87	0	0
1710.7	19957	1.4	QPSK	3	2	22.79	0	0
1710.7	19957	1.4	QPSK	3	3	22.78	0	0
1710.7	19957	1.4	QPSK	6	0	21.82	1	0-1
1710.7	19957	1.4	16-QAM	1	0	21.89	1	0-1
1710.7	19957	1.4	16-QAM	1	2	21.93	1	0-1
1710.7	19957	1.4	16-QAM	1	5	21.96	1	0-1
1710.7	19957	1.4	16-QAM	3	0	21.87	1	0-1
1710.7	19957	1.4	16-QAM	3	2	21.88	1	0-1
1710.7	19957	1.4	16-QAM	3	3	21.91	1	0-1
1710.7	19957	1.4	16-QAM	6	0	20.89	2	0-2
1732.5	20175	1.4	QPSK	1	0	22.76	0	0
1732.5	20175	1.4	QPSK	1	2	22.79	0	0
1732.5	20175	1.4	QPSK	1	5	22.92	0	0
1732.5	20175	1.4	QPSK	3	0	22.66	0	0
1732.5	20175	1.4	QPSK	3	2	22.82	0	0
1732.5	20175	1.4	QPSK	3	3	22.75	0	0
1732.5	20175	1.4	QPSK	6	0	21.81	1	0-1
1732.5	20175	1.4	16-QAM	1	0	21.77	1	0-1
1732.5	20175	1.4	16-QAM	1	2	21.86	1	0-1
1732.5	20175	1.4	16-QAM	1	5	21.93	1	0-1
1732.5	20175	1.4	16-QAM	3	0	21.85	1	0-1
1732.5	20175	1.4	16-QAM	3	2	21.89	1	0-1
1732.5	20175	1.4	16-QAM	3	3	21.98	1	0-1
1732.5	20175	1.4	16-QAM	6	0	20.83	2	0-2
1754.3	20393	1.4	QPSK	1	0	22.53	0	0
1754.3	20393	1.4	QPSK	1	2	22.51	0	0
1754.3	20393	1.4	QPSK	1	5	22.50	0	0
1754.3	20393	1.4	QPSK	3	0	22.52	0	0
1754.3	20393	1.4	QPSK	3	2	22.54	0	0
1754.3	20393	1.4	QPSK	3	3	22.42	0	0
1754.3	20393	1.4	QPSK	6	0	21.58	1	0-1
1754.3	20393	1.4	16-QAM	1	0	21.63	1	0-1
1754.3	20393	1.4	16-QAM	1	2	21.74	1	0-1
1754.3	20393	1.4	16-QAM	1	5	21.69	1	0-1
1754.3	20393	1.4	16-QAM	3	0	21.73	1	0-1
1754.3	20393	1.4	16-QAM	3	2	21.64	1	0-1
1754.3	20393	1.4	16-QAM	3	3	21.71	1	0-1
1754.3	20393	1.4	16-QAM	6	0	20.65	2	0-2

**9.2.5 LTE Band 2 (PCS)**

**Table 9-15**  
**LTE Band 2 (PCS) Conducted Powers - 10 MHz Bandwidth**

Frequency [MHz]	Channel	Bandwidth [MHz]	Modulation	RB Size	RB Offset	Conducted Power [dBm]	Target MPR [dB]	MPR Allowed per 3GPP [dB]
1855	18650	10	QPSK	1	0	23.05	0	0
1855	18650	10	QPSK	1	25	23.17	0	0
1855	18650	10	QPSK	1	49	23.14	0	0
1855	18650	10	QPSK	25	0	22.17	1	0-1
1855	18650	10	QPSK	25	12	22.11	1	0-1
1855	18650	10	QPSK	25	25	22.10	1	0-1
1855	18650	10	QPSK	50	0	22.03	1	0-1
1855	18650	10	16QAM	1	0	21.90	1	0-1
1855	18650	10	16QAM	1	25	22.00	1	0-1
1855	18650	10	16QAM	1	49	21.98	1	0-1
1855	18650	10	16QAM	25	0	21.32	2	0-2
1855	18650	10	16QAM	25	12	21.21	2	0-2
1855	18650	10	16QAM	25	25	21.14	2	0-2
1855	18650	10	16QAM	50	0	21.23	2	0-2
1880.0	18900	10	QPSK	1	0	23.49	0	0
1880.0	18900	10	QPSK	1	25	23.27	0	0
1880.0	18900	10	QPSK	1	49	23.11	0	0
1880.0	18900	10	QPSK	25	0	22.28	1	0-1
1880.0	18900	10	QPSK	25	12	22.36	1	0-1
1880.0	18900	10	QPSK	25	25	22.35	1	0-1
1880.0	18900	10	QPSK	50	0	22.22	1	0-1
1880.0	18900	10	16QAM	1	0	22.36	1	0-1
1880.0	18900	10	16QAM	1	25	22.21	1	0-1
1880.0	18900	10	16QAM	1	49	21.96	1	0-1
1880.0	18900	10	16QAM	25	0	21.19	2	0-2
1880.0	18900	10	16QAM	25	12	21.19	2	0-2
1880.0	18900	10	16QAM	25	25	21.25	2	0-2
1880.0	18900	10	16QAM	50	0	21.20	2	0-2
1905	19150	10	QPSK	1	0	23.45	0	0
1905	19150	10	QPSK	1	25	23.06	0	0
1905	19150	10	QPSK	1	49	23.08	0	0
1905	19150	10	QPSK	25	0	22.30	1	0-1
1905	19150	10	QPSK	25	12	21.94	1	0-1
1905	19150	10	QPSK	25	25	21.80	1	0-1
1905	19150	10	QPSK	50	0	21.96	1	0-1
1905	19150	10	16QAM	1	0	22.22	1	0-1
1905	19150	10	16QAM	1	25	22.42	1	0-1
1905	19150	10	16QAM	1	49	21.77	1	0-1
1905	19150	10	16QAM	25	0	21.36	2	0-2
1905	19150	10	16QAM	25	12	21.18	2	0-2
1905	19150	10	16QAM	25	25	20.78	2	0-2
1905	19150	10	16QAM	50	0	21.00	2	0-2

**Table 9-16**  
**LTE Band 2 (PCS) Conducted Powers - 5 MHz Bandwidth**

Frequency [MHz]	Channel	Bandwidth [MHz]	Modulation	RB Size	RB Offset	Conducted Power [dBm]	Target MPR [dB]	MPR Allowed per 3GPP [dB]
1852.5	18625	5	QPSK	1	0	22.80	0	0
1852.5	18625	5	QPSK	1	12	22.85	0	0
1852.5	18625	5	QPSK	1	24	22.98	0	0
1852.5	18625	5	QPSK	12	0	21.75	1	0-1
1852.5	18625	5	QPSK	12	6	21.79	1	0-1
1852.5	18625	5	QPSK	12	13	21.80	1	0-1
1852.5	18625	5	QPSK	25	0	21.78	1	0-1
1852.5	18625	5	16-QAM	1	0	22.27	1	0-1
1852.5	18625	5	16-QAM	1	12	22.44	1	0-1
1852.5	18625	5	16-QAM	1	24	22.36	1	0-1
1852.5	18625	5	16-QAM	12	0	20.97	2	0-2
1852.5	18625	5	16-QAM	12	6	21.04	2	0-2
1852.5	18625	5	16-QAM	12	13	20.98	2	0-2
1852.5	18625	5	16-QAM	25	0	20.91	2	0-2
1880.0	18900	5	QPSK	1	0	22.52	0	0
1880.0	18900	5	QPSK	1	12	22.85	0	0
1880.0	18900	5	QPSK	1	24	22.72	0	0
1880.0	18900	5	QPSK	12	0	21.70	1	0-1
1880.0	18900	5	QPSK	12	6	21.87	1	0-1
1880.0	18900	5	QPSK	12	13	21.85	1	0-1
1880.0	18900	5	QPSK	25	0	21.67	1	0-1
1880.0	18900	5	16-QAM	1	0	22.04	1	0-1
1880.0	18900	5	16-QAM	1	12	22.38	1	0-1
1880.0	18900	5	16-QAM	1	24	22.34	1	0-1
1880.0	18900	5	16-QAM	12	0	20.87	2	0-2
1880.0	18900	5	16-QAM	12	6	21.03	2	0-2
1880.0	18900	5	16-QAM	12	13	21.05	2	0-2
1880.0	18900	5	16-QAM	25	0	20.80	2	0-2
1907.5	19175	5	QPSK	1	0	22.83	0	0
1907.5	19175	5	QPSK	1	12	22.95	0	0
1907.5	19175	5	QPSK	1	24	22.88	0	0
1907.5	19175	5	QPSK	12	0	21.57	1	0-1
1907.5	19175	5	QPSK	12	6	21.51	1	0-1
1907.5	19175	5	QPSK	12	13	21.68	1	0-1
1907.5	19175	5	QPSK	25	0	21.78	1	0-1
1907.5	19175	5	16-QAM	1	0	22.11	1	0-1
1907.5	19175	5	16-QAM	1	12	22.07	1	0-1
1907.5	19175	5	16-QAM	1	24	21.93	1	0-1
1907.5	19175	5	16-QAM	12	0	20.77	2	0-2
1907.5	19175	5	16-QAM	12	6	20.72	2	0-2
1907.5	19175	5	16-QAM	12	13	20.50	2	0-2
1907.5	19175	5	16-QAM	25	0	20.52	2	0-2

**Table 9-17**  
**LTE Band 2 (PCS) Conducted Powers - 3 MHz Bandwidth**

Frequency [MHz]	Channel	Bandwidth [MHz]	Modulation	RB Size	RB Offset	Conducted Power [dBm]	Target MPR [dB]	MPR Allowed per 3GPP [dB]
1851.5	18615	3	QPSK	1	0	23.04	0	0
1851.5	18615	3	QPSK	1	7	23.00	0	0
1851.5	18615	3	QPSK	1	14	23.07	0	0
1851.5	18615	3	QPSK	8	0	21.90	1	0-1
1851.5	18615	3	QPSK	8	4	21.87	1	0-1
1851.5	18615	3	QPSK	8	7	21.94	1	0-1
1851.5	18615	3	QPSK	15	0	21.81	1	0-1
1851.5	18615	3	16-QAM	1	0	22.25	1	0-1
1851.5	18615	3	16-QAM	1	7	21.93	1	0-1
1851.5	18615	3	16-QAM	1	14	22.16	1	0-1
1851.5	18615	3	16-QAM	8	0	21.04	2	0-2
1851.5	18615	3	16-QAM	8	4	20.91	2	0-2
1851.5	18615	3	16-QAM	8	7	21.05	2	0-2
1851.5	18615	3	16-QAM	15	0	21.04	2	0-2
1880.0	18900	3	QPSK	1	0	23.22	0	0
1880.0	18900	3	QPSK	1	7	22.98	0	0
1880.0	18900	3	QPSK	1	14	23.21	0	0
1880.0	18900	3	QPSK	8	0	21.95	1	0-1
1880.0	18900	3	QPSK	8	4	21.91	1	0-1
1880.0	18900	3	QPSK	8	7	22.09	1	0-1
1880.0	18900	3	QPSK	15	0	21.99	1	0-1
1880.0	18900	3	16-QAM	1	0	22.22	1	0-1
1880.0	18900	3	16-QAM	1	7	22.04	1	0-1
1880.0	18900	3	16-QAM	1	14	22.39	1	0-1
1880.0	18900	3	16-QAM	8	0	20.89	2	0-2
1880.0	18900	3	16-QAM	8	4	21.16	2	0-2
1880.0	18900	3	16-QAM	8	7	21.08	2	0-2
1880.0	18900	3	16-QAM	15	0	21.03	2	0-2
1908.5	19185	3	QPSK	1	0	22.75	0	0
1908.5	19185	3	QPSK	1	7	22.82	0	0
1908.5	19185	3	QPSK	1	14	22.66	0	0
1908.5	19185	3	QPSK	8	0	21.50	1	0-1
1908.5	19185	3	QPSK	8	4	21.52	1	0-1
1908.5	19185	3	QPSK	8	7	21.64	1	0-1
1908.5	19185	3	QPSK	15	0	21.63	1	0-1
1908.5	19185	3	16-QAM	1	0	22.42	1	0-1
1908.5	19185	3	16-QAM	1	7	21.84	1	0-1
1908.5	19185	3	16-QAM	1	14	22.03	1	0-1
1908.5	19185	3	16-QAM	8	0	20.56	2	0-2
1908.5	19185	3	16-QAM	8	4	20.57	2	0-2
1908.5	19185	3	16-QAM	8	7	20.51	2	0-2
1908.5	19185	3	16-QAM	15	0	20.53	2	0-2

**Table 9-18**  
**LTE Band 2 (PCS) Conducted Powers -1.4 MHz Bandwidth**

Frequency [MHz]	Channel	Bandwidth [MHz]	Modulation	RB Size	RB Offset	Conducted Power [dBm]	Target MPR [dB]	MPR Allowed per 3GPP [dB]
1850.7	18607	1.4	QPSK	1	0	22.85	0	0
1850.7	18607	1.4	QPSK	1	2	22.96	0	0
1850.7	18607	1.4	QPSK	1	5	22.84	0	0
1850.7	18607	1.4	QPSK	3	0	22.75	0	0
1850.7	18607	1.4	QPSK	3	2	22.77	0	0
1850.7	18607	1.4	QPSK	3	3	22.81	0	0
1850.7	18607	1.4	QPSK	6	0	21.79	1	0-1
1850.7	18607	1.4	16-QAM	1	0	22.31	1	0-1
1850.7	18607	1.4	16-QAM	1	2	22.40	1	0-1
1850.7	18607	1.4	16-QAM	1	5	22.35	1	0-1
1850.7	18607	1.4	16-QAM	3	0	22.09	1	0-1
1850.7	18607	1.4	16-QAM	3	2	22.01	1	0-1
1850.7	18607	1.4	16-QAM	3	3	22.10	1	0-1
1850.7	18607	1.4	16-QAM	6	0	20.92	2	0-2
1880.0	18900	1.4	QPSK	1	0	22.96	0	0
1880.0	18900	1.4	QPSK	1	2	22.95	0	0
1880.0	18900	1.4	QPSK	1	5	23.02	0	0
1880.0	18900	1.4	QPSK	3	0	22.96	0	0
1880.0	18900	1.4	QPSK	3	2	23.01	0	0
1880.0	18900	1.4	QPSK	3	3	23.00	0	0
1880.0	18900	1.4	QPSK	6	0	22.07	1	0-1
1880.0	18900	1.4	16-QAM	1	0	22.07	1	0-1
1880.0	18900	1.4	16-QAM	1	2	22.43	1	0-1
1880.0	18900	1.4	16-QAM	1	5	22.18	1	0-1
1880.0	18900	1.4	16-QAM	3	0	22.03	1	0-1
1880.0	18900	1.4	16-QAM	3	2	22.05	1	0-1
1880.0	18900	1.4	16-QAM	3	3	22.16	1	0-1
1880.0	18900	1.4	16-QAM	6	0	21.03	2	0-2
1909.3	19193	1.4	QPSK	1	0	22.54	0	0
1909.3	19193	1.4	QPSK	1	2	22.64	0	0
1909.3	19193	1.4	QPSK	1	5	22.53	0	0
1909.3	19193	1.4	QPSK	3	0	22.63	0	0
1909.3	19193	1.4	QPSK	3	2	22.56	0	0
1909.3	19193	1.4	QPSK	3	3	22.51	0	0
1909.3	19193	1.4	QPSK	6	0	21.60	1	0-1
1909.3	19193	1.4	16-QAM	1	0	21.85	1	0-1
1909.3	19193	1.4	16-QAM	1	2	21.85	1	0-1
1909.3	19193	1.4	16-QAM	1	5	22.20	1	0-1
1909.3	19193	1.4	16-QAM	3	0	21.76	1	0-1
1909.3	19193	1.4	16-QAM	3	2	21.91	1	0-1
1909.3	19193	1.4	16-QAM	3	3	21.68	1	0-1
1909.3	19193	1.4	16-QAM	6	0	20.54	2	0-2

### 9.3 WLAN Conducted Powers

**Table 9-19**  
**IEEE 802.11b Average RF Power**

Mode	Freq [MHz]	Channel	802.11b (2.4 GHz) Conducted Power [dBm]			
			Data Rate [Mbps]			
			1	2	5.5	11
802.11b	2412	1*	13.59	13.19	13.69	16.11
802.11b	2437	6*	16.44	16.46	16.08	16.06
802.11b	2462	11*	16.41	15.47	16.00	15.55

**Table 9-20**  
**IEEE 802.11g Average RF Power**

Mode	Freq [MHz]	Channel	802.11g (2.4 GHz) Conducted Power [dBm]							
			Data Rate [Mbps]							
			6	9	12	18	24	36	48	54
802.11g	2412	1	11.16	11.26	11.79	11.82	11.78	11.84	11.81	11.83
802.11g	2437	6	13.15	13.71	13.21	13.78	13.23	12.81	13.26	13.24
802.11g	2462	11	13.16	13.38	13.39	13.98	13.96	13.49	13.53	13.54

**Table 9-21  
IEEE 802.11n Average RF Power**



Mode	Freq [MHz]	Channel	802.11n (2.4 GHz) Conducted Power [dBm]							
			Data Rate [Mbps]							
			6.5	13	20	26	39	52	58	65
802.11n	2412	1	11.33	11.85	12.37	12.38	11.95	11.94	11.44	12.48
802.11n	2437	6	12.74	13.31	13.88	13.39	13.41	12.88	13.36	13.90
802.11n	2462	11	12.97	13.88	13.59	13.16	13.55	13.68	13.16	13.13

Justification for reduced test configurations for WIFI channels per KDB Publication 248227 D01v01r02 and October 2012 FCC/TCB Meeting Notes:

- For 2.4 GHz, highest average RF output power channel for the lowest data rate for IEEE 802.11b were selected for SAR evaluation. Other IEEE 802.11 modes (including 802.11g/n) were not investigated since the average output powers over all channels and data rates were not more than 0.25 dB higher than the tested channel in the lowest data rate of IEEE 802.11b mode.
- Since the maximum extrapolated peak SAR of the zoom scan for the maximum output channel is <1.6 W/kg and the reported 1g averaged SAR is <0.8 W/kg, SAR testing on other channels is not required.
- The bolded data rate and channel above were tested for SAR.



**Figure 9-2  
Power Measurement Setup**

FCC ID: V65C6721A1		SAR EVALUATION REPORT		Reviewed by: Quality Manager
Document S/N: 0Y1212071742-R4.V65	Test Dates: 12/10/12 - 02/22/13	DUT Type: Portable Handset		Page 29 of 82

# 10 LTE POWER REDUCTION

## 10.1 Introduction to LTE Power Reduction

This device is capable of Simultaneous Voice and LTE (SVLTE) calls, with the voice call supported by a CDMA 1x-RTT transmitter and the data connection supported by a separate LTE transmitter. A LTE power reduction scheme is applied during a LTE connection operating simultaneously with 1x-RTT voice calls. The maximum transmit power of LTE is limited depending on the CDMA 1x voice transmit power level. When CDMA 1x Voice is operating at a certain range of high power levels, the maximum LTE transmit power is limited. When CDMA 1x Voice transmit power is below a certain threshold transmit power level, LTE can transmit at the maximum power. Target levels of power reduction and CDMA voice threshold levels are provided in Table 10-1.

**Table 10-1  
SVLTE Power Reduction Scheme**

CDMA BC15 and LTE Band 12		CDMA BC1 and LTE Band 12		CDMA BC15 and LTE Band 17		CDMA BC1 and LTE Band 17		CDMA BC15 and LTE Band 5		CDMA BC1 and LTE Band 5	
1xPower [dBm]	LTE Limit [dBm]	1xPower [dBm]	LTE Limit [dBm]	1xPower [dBm]	LTE Limit [dBm]	1xPower [dBm]	LTE Limit [dBm]	1xPower [dBm]	LTE Limit [dBm]	1xPower [dBm]	LTE Limit [dBm]
≥20	18	≥20	19	≥20	18.5	≥20	19.5	≥20	18	≥20	19.5
<20	23	<20	23	<20	23	<20	23	<20	23	<20	23

CDMA BC0 and LTE Band 4		CDMA BC15 and LTE Band 4		CDMA BC1 and LTE Band 4		CDMA BC0 and LTE Band 2		CDMA BC15 and LTE Band 2		CDMA BC1 and LTE Band 2	
1xPower [dBm]	LTE Limit [dBm]	1xPower [dBm]	LTE Limit [dBm]	1xPower [dBm]	LTE Limit [dBm]	1xPower [dBm]	LTE Limit [dBm]	1xPower [dBm]	LTE Limit [dBm]	1xPower [dBm]	LTE Limit [dBm]
≥15	19	≥10	15	≥10	15	≥15	19	≥10	15	≥10	15
<15	22.5	<10	22.5	<10	22.5	<15	23	<10	23	<10	23

Note: There is no SVLTE power reduction operating in CDMA BC0 with LTE Bands 12, 17 and 5.

## 10.2 Output Power Verification

Per KDB Publication 941225 D05v02 Section 4.4, output powers were measured in SVLTE mode to determine that the power reduction mechanism was operating reliably and consistently. The power reduction was investigated by simultaneously connecting the device to both LTE and CDMA base station simulators. LTE output powers were measured through conducted RF connections by first connecting the device in a LTE data call and subsequently a CDMA 1x-RTT call. CDMA powers were controlled by configuring the CDMA base station simulator to active bits. The LTE output power was monitored while changing the cell output power level.

The power reduction targets and threshold level described in Table 10-1 were confirmed. Please see results in Table 10-2.

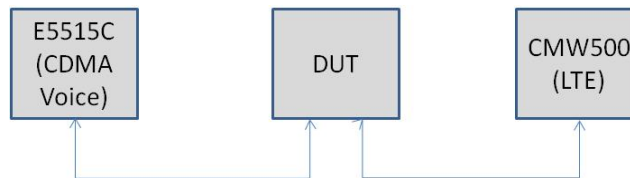

**Figure 10-1  
SVLTE Conducted Test Setup Diagram**

FCC ID: V65C6721A1	PCTEST ENGINEERING LABORATORY, INC.	SAR EVALUATION REPORT	KYOCERA	Reviewed by: Quality Manager
Document S/N: 0Y1212071742-R4.V65	Test Dates: 12/10/12 - 02/22/13	DUT Type: Portable Handset		Page 30 of 82

**Table 10-2  
SVLTE Power Reduction Verification Results**

BC15 1x-RTT CDMA Voice Channel		LTE Band 12 Conducted Power (dBm)													
		10 MHz BW, Mid ch.													
		QPSK 1 RB 0 RB Offset	QPSK 1 RB 25 RB Offset	QPSK 1 RB 49 RB Offset	QPSK 25 RB 0 RB Offset	QPSK 25 RB 12 RB Offset	QPSK 25 RB 25 RB Offset	QPSK 50 RB 0 RB Offset	16QAM 1 RB 0 RB Offset	16QAM 1 RB 25 RB Offset	16QAM 1 RB 49 RB Offset	16QAM 25 RB 0 RB Offset	16QAM 25 RB 12 RB Offset	16QAM 25 RB 25 RB Offset	16QAM 50 RB 0 RB Offset
450 (Mid)	23.5	17.81	18.08	18.03	17.90	17.97	17.96	18.00	17.84	18.12	18.08	17.85	17.98	17.92	17.96
	20.5	17.82	18.11	18.10	17.94	18.07	18.02	18.05	17.88	18.18	18.11	17.87	18.03	17.94	17.97
	19.5	23.33	23.54	23.42	22.30	22.49	22.36	22.30	22.31	22.70	22.51	21.37	21.46	21.38	21.38
	11	23.29	23.58	23.47	22.34	22.46	22.37	22.32	22.38	22.69	22.56	21.34	21.47	21.35	21.30
BC1 1x-RTT CDMA Voice Channel		LTE Band 12 Conducted Power (dBm)													
		10 MHz BW, Mid ch.													
		QPSK 1 RB 0 RB Offset	QPSK 1 RB 25 RB Offset	QPSK 1 RB 49 RB Offset	QPSK 25 RB 0 RB Offset	QPSK 25 RB 12 RB Offset	QPSK 25 RB 25 RB Offset	QPSK 50 RB 0 RB Offset	16QAM 1 RB 0 RB Offset	16QAM 1 RB 25 RB Offset	16QAM 1 RB 49 RB Offset	16QAM 25 RB 0 RB Offset	16QAM 25 RB 12 RB Offset	16QAM 25 RB 25 RB Offset	16QAM 50 RB 0 RB Offset
600 (Mid)	23.5	19.30	19.54	19.40	19.33	19.41	19.36	19.36	19.65	19.55	19.42	19.35	19.39	19.35	19.32
	20.5	19.61	19.69	19.67	19.38	19.56	19.44	19.41	19.70	19.65	19.53	19.43	19.45	19.39	19.35
	18	23.28	23.47	23.42	22.26	22.44	22.34	22.37	22.32	22.66	22.72	21.30	21.41	21.39	21.37
	11	23.35	23.60	23.47	22.32	22.48	22.36	22.38	22.39	22.70	22.56	21.33	21.43	21.39	21.27
BC15 1x-RTT CDMA Voice Channel		LTE Band 17 Conducted Power (dBm)													
		10 MHz BW, Mid ch.													
		QPSK 1 RB 0 RB Offset	QPSK 1 RB 25 RB Offset	QPSK 1 RB 49 RB Offset	QPSK 25 RB 0 RB Offset	QPSK 25 RB 12 RB Offset	QPSK 25 RB 25 RB Offset	QPSK 50 RB 0 RB Offset	16QAM 1 RB 0 RB Offset	16QAM 1 RB 25 RB Offset	16QAM 1 RB 49 RB Offset	16QAM 25 RB 0 RB Offset	16QAM 25 RB 12 RB Offset	16QAM 25 RB 25 RB Offset	16QAM 50 RB 0 RB Offset
450 (Mid)	23.5	18.99	18.98	18.88	18.99	18.93	18.88	18.91	18.89	18.80	18.94	18.88	18.81	18.92	18.88
	20.5	18.99	18.85	18.98	18.94	18.86	18.93	18.97	18.64	18.81	18.91	18.86	18.85	18.90	18.97
	19.5	23.54	23.44	23.61	22.42	22.27	22.22	22.48	22.57	22.53	22.61	21.23	21.20	21.24	21.21
	11	23.41	23.43	23.49	22.24	22.21	22.31	22.54	22.30	22.18	22.40	21.27	21.05	21.25	21.28
BC1 1x-RTT CDMA Voice Channel		LTE Band 17 Conducted Power (dBm)													
		10 MHz BW, Mid ch.													
		QPSK 1 RB 0 RB Offset	QPSK 1 RB 25 RB Offset	QPSK 1 RB 49 RB Offset	QPSK 25 RB 0 RB Offset	QPSK 25 RB 12 RB Offset	QPSK 25 RB 25 RB Offset	QPSK 50 RB 0 RB Offset	16QAM 1 RB 0 RB Offset	16QAM 1 RB 25 RB Offset	16QAM 1 RB 49 RB Offset	16QAM 25 RB 0 RB Offset	16QAM 25 RB 12 RB Offset	16QAM 25 RB 25 RB Offset	16QAM 50 RB 0 RB Offset
600 (Mid)	23.5	19.55	19.64	19.74	19.35	19.35	19.41	19.44	19.57	19.55	19.72	19.42	19.37	19.43	19.43
	20.5	19.61	19.60	19.70	19.39	19.48	19.45	19.42	19.55	19.56	19.73	19.51	19.41	19.51	19.52
	18	23.62	23.48	23.68	22.31	22.28	22.31	22.39	22.62	22.58	22.66	21.38	20.35	21.38	21.32
	11	23.55	23.48	23.64	22.35	22.33	22.28	22.31	22.63	22.59	22.68	21.36	21.33	21.39	21.30
BC15 1x-RTT CDMA Voice Channel		LTE Band 5 Conducted Power (dBm)													
		10 MHz BW, Mid ch.													
		QPSK 1 RB 0 RB Offset	QPSK 1 RB 25 RB Offset	QPSK 1 RB 49 RB Offset	QPSK 25 RB 0 RB Offset	QPSK 25 RB 12 RB Offset	QPSK 25 RB 25 RB Offset	QPSK 50 RB 0 RB Offset	16QAM 1 RB 0 RB Offset	16QAM 1 RB 25 RB Offset	16QAM 1 RB 49 RB Offset	16QAM 25 RB 0 RB Offset	16QAM 25 RB 12 RB Offset	16QAM 25 RB 25 RB Offset	16QAM 50 RB 0 RB Offset
450 (Mid)	23.5	17.97	18.18	18.04	18.01	18.10	17.93	17.96	18.43	18.17	18.08	18.01	18.10	18.02	17.94
	20.5	17.90	18.17	18.05	18.05	18.03	17.98	17.90	18.15	18.16	18.04	17.99	18.09	18.02	17.95
	19.5	23.55	23.62	23.57	22.50	22.53	22.49	22.40	22.59	22.70	22.69	21.53	21.64	21.55	21.21
	11	23.34	23.66	23.52	22.53	22.60	22.50	22.36	22.60	22.51	22.59	21.53	21.67	21.57	21.45
BC1 1x-RTT CDMA Voice Channel		LTE Band 5 Conducted Power (dBm)													
		10 MHz BW, Mid ch.													
		QPSK 1 RB 0 RB Offset	QPSK 1 RB 25 RB Offset	QPSK 1 RB 49 RB Offset	QPSK 25 RB 0 RB Offset	QPSK 25 RB 12 RB Offset	QPSK 25 RB 25 RB Offset	QPSK 50 RB 0 RB Offset	16QAM 1 RB 0 RB Offset	16QAM 1 RB 25 RB Offset	16QAM 1 RB 49 RB Offset	16QAM 25 RB 0 RB Offset	16QAM 25 RB 12 RB Offset	16QAM 25 RB 25 RB Offset	16QAM 50 RB 0 RB Offset
600 (Mid)	23.5	19.54	19.65	19.52	19.47	19.44	19.60	19.48	19.72	19.65	19.52	19.46	19.55	19.43	19.37
	20.5	19.53	19.57	19.56	19.43	19.51	19.42	19.45	19.49	19.70	19.59	19.41	19.58	19.50	19.40
	18	23.52	23.66	23.50	22.53	22.51	22.42	22.38	22.58	22.65	22.62	21.47	21.55	21.49	21.44
	11	23.56	23.66	23.50	22.45	22.49	22.47	22.41	22.67	22.66	22.68	21.59	21.57	21.47	21.39
BC0 1x-RTT CDMA Voice Channel		LTE Band 4 Conducted Power (dBm)													
		10 MHz BW, Mid ch.													
		QPSK 1 RB 0 RB Offset	QPSK 1 RB 25 RB Offset	QPSK 1 RB 49 RB Offset	QPSK 25 RB 0 RB Offset	QPSK 25 RB 12 RB Offset	QPSK 25 RB 25 RB Offset	QPSK 50 RB 0 RB Offset	16QAM 1 RB 0 RB Offset	16QAM 1 RB 25 RB Offset	16QAM 1 RB 49 RB Offset	16QAM 25 RB 0 RB Offset	16QAM 25 RB 12 RB Offset	16QAM 25 RB 25 RB Offset	16QAM 50 RB 0 RB Offset
384 (Mid)	24.5	19.08	19.13	19.11	18.98	18.98	19.21	19.01	18.96	19.07	19.01	19.01	19.01	19.18	18.87
	15.5	18.88	19.19	19.13	19.06	19.01	19.05	18.98	18.65	18.73	19.19	19.00	18.99	19.14	18.93
	13	22.81	22.89	22.79	21.76	21.68	21.74	21.54	21.95	22.00	20.91	20.71	20.72	20.79	20.58
	11	22.82	22.83	22.81	21.69	21.73	21.76	21.57	21.94	22.04	21.89	20.72	20.73	20.80	20.55
BC15 1x-RTT CDMA Voice Channel		LTE Band 4 Conducted Power (dBm)													
		10 MHz BW, Mid ch.													
		QPSK 1 RB 0 RB Offset	QPSK 1 RB 25 RB Offset	QPSK 1 RB 49 RB Offset	QPSK 25 RB 0 RB Offset	QPSK 25 RB 12 RB Offset	QPSK 25 RB 25 RB Offset	QPSK 50 RB 0 RB Offset	16QAM 1 RB 0 RB Offset	16QAM 1 RB 25 RB Offset	16QAM 1 RB 49 RB Offset	16QAM 25 RB 0 RB Offset	16QAM 25 RB 12 RB Offset	16QAM 25 RB 25 RB Offset	16QAM 50 RB 0 RB Offset
450 (Mid)	23.5	15.07	14.99	14.76	14.94	14.92	14.88	14.95	15.27	15.14	14.93	14.97	14.96	14.93	14.99
	10.5	15.09	15.01	14.81	15.15	15.13	15.09	15.17	15.51	15.37	15.13	15.16	15.15	15.12	15.19
	9	22.97	22.89	22.84	21.82	21.73	21.76	21.60	22.00	22.03	21.92	20.75	20.78	20.81	20.60
	8	22.89	22.88	22.87	21.75	21.71	21.74	21.62	21.98	22.00	21.89	20.71	20.75	20.76	20.61
BC1 1x-RTT CDMA Voice Channel		LTE Band 4 Conducted Power (dBm)													
		10 MHz BW, Mid ch.													
		QPSK 1 RB 0 RB Offset	QPSK 1 RB 25 RB Offset	QPSK 1 RB 49 RB Offset	QPSK 25 RB 0 RB Offset	QPSK 25 RB 12 RB Offset	QPSK 25 RB 25 RB Offset	QPSK 50 RB 0 RB Offset	16QAM 1 RB 0 RB Offset	16QAM 1 RB 25 RB Offset	16QAM 1 RB 49 RB Offset	16QAM 25 RB 0 RB Offset	16QAM 25 RB 12 RB Offset	16QAM 25 RB 25 RB Offset	16QAM 50 RB 0 RB Offset
600 (Mid)	23.5	15.27	15.29	15.05	15.28	15.25	15.21	15.28	15.41	15.33	15.28	15.11	15.20	15.19	15.10
	10.5	15.23	15.27	15.15	15.08	15.40	15.38	14.88	15.17	15.08	15.33	14.92	14.90	14.91	14.97
	9	22.82	22.87	22.83	21.72	21.64	21.77	21.58	21.95	22.02	21.94	20.73	20.68	20.71	20.57
	8	22.86	22.87	22.74	21.59	21.60	21.73	21.58	21.83	21.95	21.84	20.72	20.67	20.73	20.62

BC0 1x-RTT CDMA Voice Channel	BC0 1x-RTT CDMA Voice Tx(dBm)	LTE Band 2 Conducted Power (dBm)													
		10 MHz BW, Mid ch.													
		QPSK 1 RB 0 RB Offset	QPSK 1 RB 25 RB Offset	QPSK 1 RB 49 RB Offset	QPSK 25 RB 0 RB Offset	QPSK 25 RB 12 RB Offset	QPSK 25 RB 25 RB Offset	QPSK 50 RB 0 RB Offset	16QAM 1 RB 0 RB Offset	16QAM 1 RB 25 RB Offset	16QAM 1 RB 49 RB Offset	16QAM 25 RB 0 RB Offset	16QAM 25 RB 12 RB Offset	16QAM 25 RB 25 RB Offset	16QAM 50 RB 0 RB Offset
384 (Mid)	24.5	19.11	19.15	19.16	18.89	19.07	19.10	18.98	19.07	19.17	19.21	18.97	19.12	19.19	18.95
	15.5	19.00	19.18	19.22	18.90	18.97	19.07	18.96	19.02	19.15	19.18	18.90	19.04	19.08	18.87
	13	23.68	23.58	23.65	22.65	22.62	22.66	22.67	22.44	22.55	22.47	21.67	21.52	21.57	21.64
	8	23.70	23.62	23.68	22.64	22.70	22.65	22.64	22.45	22.55	22.63	21.69	21.50	21.59	21.58
BC15 1x-RTT CDMA Voice Channel	BC15 1x-RTT CDMA Voice Tx(dBm)	LTE Band 2 Conducted Power (dBm)													
		10 MHz BW, Mid ch.													
		QPSK 1 RB 0 RB Offset	QPSK 1 RB 25 RB Offset	QPSK 1 RB 49 RB Offset	QPSK 25 RB 0 RB Offset	QPSK 25 RB 12 RB Offset	QPSK 25 RB 25 RB Offset	QPSK 50 RB 0 RB Offset	16QAM 1 RB 0 RB Offset	16QAM 1 RB 25 RB Offset	16QAM 1 RB 49 RB Offset	16QAM 25 RB 0 RB Offset	16QAM 25 RB 12 RB Offset	16QAM 25 RB 25 RB Offset	16QAM 50 RB 0 RB Offset
450 (Mid)	23.5	15.57	15.52	15.41	15.30	15.39	15.47	15.40	14.93	14.90	14.85	14.87	14.98	15.11	15.02
	10.5	15.68	15.67	15.58	15.32	15.42	15.47	15.35	15.39	15.34	15.19	15.11	15.09	15.22	15.07
	9	23.63	23.64	23.66	22.42	22.63	22.68	22.48	22.64	22.70	22.67	21.47	21.44	21.40	21.48
	8	23.61	23.61	23.62	22.45	22.59	22.65	22.54	22.69	22.65	22.68	21.50	21.65	21.69	21.49
BC1 1x-RTT CDMA Voice Channel	BC1 1x-RTT CDMA Voice Tx(dBm)	LTE Band 2 Conducted Power (dBm)													
		10 MHz BW, Mid ch.													
		QPSK 1 RB 0 RB Offset	QPSK 1 RB 25 RB Offset	QPSK 1 RB 49 RB Offset	QPSK 25 RB 0 RB Offset	QPSK 25 RB 12 RB Offset	QPSK 25 RB 25 RB Offset	QPSK 50 RB 0 RB Offset	16QAM 1 RB 0 RB Offset	16QAM 1 RB 25 RB Offset	16QAM 1 RB 49 RB Offset	16QAM 25 RB 0 RB Offset	16QAM 25 RB 12 RB Offset	16QAM 25 RB 25 RB Offset	16QAM 50 RB 0 RB Offset
600 (Mid)	23.5	15.10	15.17	15.14	14.95	15.10	15.17	15.15	14.83	15.32	14.50	14.99	15.03	14.84	14.81
	10.5	15.13	15.20	15.19	15.01	15.17	15.33	15.16	15.09	15.26	14.81	14.93	15.18	14.71	14.65
	9	23.57	23.68	23.70	22.38	22.50	22.63	22.38	22.67	22.67	22.69	21.45	21.60	21.69	21.44
	8	23.62	23.61	23.66	22.35	22.53	22.62	22.44	22.65	22.67	22.70	21.48	21.63	21.69	21.34

Note: The low and high channels as well as the lower bandwidths were confirmed to operate according to the SVLTE power reduction scheme.

### 10.3 SVLTE SAR Testing Procedures

Per KDB 941225 D05v02 Section 4.4 B), SAR testing was additionally performed at the reduced CDMA and LTE power levels with respect to the simultaneous transmission scenarios. Samples were tuned to fixed reduced power levels to represent the SVLTE condition in a standalone environment. While the power reduction mechanism is activated at the specified CDMA Voice power level (see Table 10-1) simultaneous SAR summations of maximum power LTE were evaluated at this reduced fixed CDMA voice power level. SAR was additionally evaluated at reduced power LTE levels to perform simultaneous SAR analysis when CDMA voice is at maximum power.



#### 10.3.1 Reduced LTE Band 12 Conducted Powers

**Table 10-3**  
Reduced LTE Band 12 Conducted Powers Target 19 dBm – 10 MHz Bandwidth

Frequency [MHz]	Channel	Bandwidth [MHz]	Modulation	RB Size	RB Offset	Conducted Power [dBm]	Target MPR [dB]	MPR Allowed per 3GPP [dB]
707.5	23095	10	QPSK	1	0	19.28	0	0
707.5	23095	10	QPSK	1	25	<b>19.55</b>	0	0
707.5	23095	10	QPSK	1	49	19.44	0	0
707.5	23095	10	QPSK	25	0	19.33	0	0-1
707.5	23095	10	QPSK	25	12	<b>19.44</b>	0	0-1
707.5	23095	10	QPSK	25	25	19.38	0	0-1
707.5	23095	10	QPSK	50	0	19.37	0	0-1
707.5	23095	10	16QAM	1	0	19.68	0	0-1
707.5	23095	10	16QAM	1	25	19.55	0	0-1
707.5	23095	10	16QAM	1	49	19.41	0	0-1
707.5	23095	10	16QAM	25	0	19.33	0	0-2
707.5	23095	10	16QAM	25	12	19.38	0	0-2
707.5	23095	10	16QAM	25	25	19.35	0	0-2
707.5	23095	10	16QAM	50	0	19.31	0	0-2

LTE Notes:

1. Please refer to Section 8.4.4 for LTE testing requirements per FCC KDB 941225 D05.
2. The bolded powers were tested for SAR.
3. LTE Band 12 at 10 MHz Bandwidth does not support three non-overlapping channels. Per KDB 941225 D05v02, when a device supports overlapping channel assignment in a channel bandwidth configuration, the mid channel of the group of overlapping channels should be selected for testing

FCC ID: V65C6721A1		SAR EVALUATION REPORT		Reviewed by: Quality Manager
Document S/N: OY1212071742-R4.V65	Test Dates: 12/10/12 - 02/22/13	DUT Type: Portable Handset	Page 32 of 82	



**Table 10-4**  
**Reduced LTE Band 12 Conducted Powers Target 19 dBm – 5 MHz Bandwidth**

Frequency [MHz]	Channel	Bandwidth [MHz]	Modulation	RB Size	RB Offset	Conducted Power [dBm]	Target MPR [dB]	MPR Allowed per 3GPP [dB]
701.5	23035	5	QPSK	1	0	19.62	0	0
701.5	23035	5	QPSK	1	12	19.54	0	0
701.5	23035	5	QPSK	1	24	19.51	0	0
701.5	23035	5	QPSK	12	0	19.42	0	0-1
701.5	23035	5	QPSK	12	6	19.38	0	0-1
701.5	23035	5	QPSK	12	13	19.28	0	0-1
701.5	23035	5	QPSK	25	0	19.37	0	0-1
701.5	23035	5	16-QAM	1	0	19.46	0	0-1
701.5	23035	5	16-QAM	1	12	19.62	0	0-1
701.5	23035	5	16-QAM	1	24	19.38	0	0-1
701.5	23035	5	16-QAM	12	0	19.43	0	0-2
701.5	23035	5	16-QAM	12	6	19.52	0	0-2
701.5	23035	5	16-QAM	12	13	19.33	0	0-2
701.5	23035	5	16-QAM	25	0	19.24	0	0-2
707.5	23095	5	QPSK	1	0	19.56	0	0
707.5	23095	5	QPSK	1	12	19.48	0	0
707.5	23095	5	QPSK	1	24	19.40	0	0
707.5	23095	5	QPSK	12	0	19.43	0	0-1
707.5	23095	5	QPSK	12	6	19.38	0	0-1
707.5	23095	5	QPSK	12	13	19.35	0	0-1
707.5	23095	5	QPSK	25	0	19.46	0	0-1
707.5	23095	5	16-QAM	1	0	19.58	0	0-1
707.5	23095	5	16-QAM	1	12	19.54	0	0-1
707.5	23095	5	16-QAM	1	24	19.37	0	0-1
707.5	23095	5	16-QAM	12	0	19.50	0	0-2
707.5	23095	5	16-QAM	12	6	19.52	0	0-2
707.5	23095	5	16-QAM	12	13	19.42	0	0-2
707.5	23095	5	16-QAM	25	0	19.34	0	0-2
713.5	23155	5	QPSK	1	0	19.60	0	0
713.5	23155	5	QPSK	1	12	19.24	0	0
713.5	23155	5	QPSK	1	24	19.21	0	0
713.5	23155	5	QPSK	12	0	19.37	0	0-1
713.5	23155	5	QPSK	12	6	19.17	0	0-1
713.5	23155	5	QPSK	12	13	19.10	0	0-1
713.5	23155	5	QPSK	25	0	19.12	0	0-1
713.5	23155	5	16-QAM	1	0	19.58	0	0-1
713.5	23155	5	16-QAM	1	12	19.50	0	0-1
713.5	23155	5	16-QAM	1	24	19.47	0	0-1
713.5	23155	5	16-QAM	12	0	19.32	0	0-2
713.5	23155	5	16-QAM	12	6	19.15	0	0-2
713.5	23155	5	16-QAM	12	13	19.05	0	0-2
713.5	23155	5	16-QAM	25	0	19.11	0	0-2

**Table 10-5**  
**Reduced LTE Band 12 Conducted Powers Target 19 dBm – 3 MHz Bandwidth**

Frequency [MHz]	Channel	Bandwidth [MHz]	Modulation	RB Size	RB Offset	Conducted Power [dBm]	Target MPR [dB]	MPR Allowed per 3GPP [dB]
700.5	23025	3	QPSK	1	0	19.44	0	0
700.5	23025	3	QPSK	1	7	19.47	0	0
700.5	23025	3	QPSK	1	14	19.65	0	0
700.5	23025	3	QPSK	8	0	19.55	0	0-1
700.5	23025	3	QPSK	8	4	19.48	0	0-1
700.5	23025	3	QPSK	8	7	19.64	0	0-1
700.5	23025	3	QPSK	15	0	19.56	0	0-1
700.5	23025	3	16-QAM	1	0	19.55	0	0-1
700.5	23025	3	16-QAM	1	7	19.56	0	0-1
700.5	23025	3	16-QAM	1	14	19.64	0	0-1
700.5	23025	3	16-QAM	8	0	19.48	0	0-2
700.5	23025	3	16-QAM	8	4	19.47	0	0-2
700.5	23025	3	16-QAM	8	7	19.64	0	0-2
700.5	23025	3	16-QAM	15	0	19.53	0	0-2
707.5	23095	3	QPSK	1	0	19.59	0	0
707.5	23095	3	QPSK	1	7	19.54	0	0
707.5	23095	3	QPSK	1	14	19.60	0	0
707.5	23095	3	QPSK	8	0	19.53	0	0-1
707.5	23095	3	QPSK	8	4	19.52	0	0-1
707.5	23095	3	QPSK	8	7	19.57	0	0-1
707.5	23095	3	QPSK	15	0	19.46	0	0-1
707.5	23095	3	16-QAM	1	0	19.66	0	0-1
707.5	23095	3	16-QAM	1	7	19.64	0	0-1
707.5	23095	3	16-QAM	1	14	19.61	0	0-1
707.5	23095	3	16-QAM	8	0	19.52	0	0-2
707.5	23095	3	16-QAM	8	4	19.46	0	0-2
707.5	23095	3	16-QAM	8	7	19.52	0	0-2
707.5	23095	3	16-QAM	15	0	19.47	0	0-2
714.5	23165	3	QPSK	1	0	19.15	0	0
714.5	23165	3	QPSK	1	7	19.04	0	0
714.5	23165	3	QPSK	1	14	19.08	0	0
714.5	23165	3	QPSK	8	0	19.04	0	0-1
714.5	23165	3	QPSK	8	4	19.03	0	0-1
714.5	23165	3	QPSK	8	7	19.00	0	0-1
714.5	23165	3	QPSK	15	0	19.01	0	0-1
714.5	23165	3	16-QAM	1	0	19.10	0	0-1
714.5	23165	3	16-QAM	1	7	19.11	0	0-1
714.5	23165	3	16-QAM	1	14	19.05	0	0-1
714.5	23165	3	16-QAM	8	0	19.00	0	0-2
714.5	23165	3	16-QAM	8	4	19.01	0	0-2
714.5	23165	3	16-QAM	8	7	19.02	0	0-2
714.5	23165	3	16-QAM	15	0	19.04	0	0-2

**Table 10-6**  
**Reduced LTE Band 12 Conducted Powers Target 19 dBm – 1.4 MHz Bandwidth**



Frequency [MHz]	Channel	Bandwidth [MHz]	Modulation	RB Size	RB Offset	Conducted Power [dBm]	Target MPR [dB]	MPR Allowed per 3GPP [dB]
699.7	23017	1.4	QPSK	1	0	19.54	0	0
699.7	23017	1.4	QPSK	1	2	19.53	0	0
699.7	23017	1.4	QPSK	1	5	19.56	0	0
699.7	23017	1.4	QPSK	3	0	19.60	0	0
699.7	23017	1.4	QPSK	3	2	19.52	0	0
699.7	23017	1.4	QPSK	3	3	19.57	0	0
699.7	23017	1.4	QPSK	6	0	19.53	0	0
699.7	23017	1.4	16-QAM	1	0	19.55	0	0-1
699.7	23017	1.4	16-QAM	1	2	19.56	0	0-1
699.7	23017	1.4	16-QAM	1	5	19.61	0	0-1
699.7	23017	1.4	16-QAM	3	0	19.58	0	0-1
699.7	23017	1.4	16-QAM	3	2	19.49	0	0-1
699.7	23017	1.4	16-QAM	3	3	19.55	0	0-1
699.7	23017	1.4	16-QAM	6	0	19.46	0	0-2
707.5	23095	1.4	QPSK	1	0	19.66	0	0
707.5	23095	1.4	QPSK	1	2	19.68	0	0
707.5	23095	1.4	QPSK	1	5	19.62	0	0
707.5	23095	1.4	QPSK	3	0	19.64	0	0
707.5	23095	1.4	QPSK	3	2	19.56	0	0
707.5	23095	1.4	QPSK	3	3	19.60	0	0
707.5	23095	1.4	QPSK	6	0	19.54	0	0-1
707.5	23095	1.4	16-QAM	1	0	19.67	0	0-1
707.5	23095	1.4	16-QAM	1	2	19.69	0	0-1
707.5	23095	1.4	16-QAM	1	5	19.64	0	0-1
707.5	23095	1.4	16-QAM	3	0	19.63	0	0-1
707.5	23095	1.4	16-QAM	3	2	19.58	0	0-1
707.5	23095	1.4	16-QAM	3	3	19.56	0	0-1
707.5	23095	1.4	16-QAM	6	0	19.51	0	0-2
715.3	23173	1.4	QPSK	1	0	19.01	0	0
715.3	23173	1.4	QPSK	1	2	19.00	0	0
715.3	23173	1.4	QPSK	1	5	19.08	0	0
715.3	23173	1.4	QPSK	3	0	19.04	0	0
715.3	23173	1.4	QPSK	3	2	19.01	0	0
715.3	23173	1.4	QPSK	3	3	19.06	0	0
715.3	23173	1.4	QPSK	6	0	19.00	0	0-1
715.3	23173	1.4	16-QAM	1	0	19.04	0	0-1
715.3	23173	1.4	16-QAM	1	2	19.06	0	0-1
715.3	23173	1.4	16-QAM	1	5	19.11	0	0-1
715.3	23173	1.4	16-QAM	3	0	19.03	0	0-1
715.3	23173	1.4	16-QAM	3	2	19.01	0	0-1
715.3	23173	1.4	16-QAM	3	3	19.04	0	0-1
715.3	23173	1.4	16-QAM	6	0	19.00	0	0-2

**Table 10-7**  
**Reduced LTE Band 12 Conducted Powers Target 18 dBm – 10 MHz Bandwidth**

Frequency [MHz]	Channel	Bandwidth [MHz]	Modulation	RB Size	RB Offset	Conducted Power [dBm]	Target MPR [dB]	MPR Allowed per 3GPP [dB]
707.5	23095	10	QPSK	1	0	17.64	0	0
707.5	23095	10	QPSK	1	25	<b>17.95</b>	0	0
707.5	23095	10	QPSK	1	49	17.95	0	0
707.5	23095	10	QPSK	25	0	17.74	0	0-1
707.5	23095	10	QPSK	25	12	<b>17.90</b>	0	0-1
707.5	23095	10	QPSK	25	25	17.82	0	0-1
707.5	23095	10	QPSK	50	0	17.85	0	0-1
707.5	23095	10	16QAM	1	0	17.74	0	0-1
707.5	23095	10	16QAM	1	25	18.05	0	0-1
707.5	23095	10	16QAM	1	49	18.00	0	0-1
707.5	23095	10	16QAM	25	0	17.77	0	0-2
707.5	23095	10	16QAM	25	12	17.89	0	0-2
707.5	23095	10	16QAM	25	25	17.84	0	0-2
707.5	23095	10	16QAM	50	0	17.81	0	0-2

LTE Notes:

1. Please refer to Section 8.4.4 for LTE testing requirements per FCC KDB 941225 D05.
2. The bolded powers were tested for SAR.
3. LTE Band 12 at 10 MHz bandwidth does not support three non-overlapping channels. Per KDB 941225 D05v02, when a device supports overlapping channel assignment in a channel bandwidth configuration, the mid channel of the group of overlapping channels should be selected for testing

FCC ID: V65C6721A1		SAR EVALUATION REPORT		Reviewed by: Quality Manager
Document S/N: 0Y1212071742-R4.V65	Test Dates: 12/10/12 - 02/22/13	DUT Type: Portable Handset		Page 34 of 82



**Table 10-8**  
**Reduced LTE Band 12 Conducted Powers Target 18 dBm – 5 MHz Bandwidth**

Frequency [MHz]	Channel	Bandwidth [MHz]	Modulation	RB Size	RB Offset	Conducted Power [dBm]	Target MPR [dB]	MPR Allowed per 3GPP [dB]
701.5	23035	5	QPSK	1	0	18.16	0	0
701.5	23035	5	QPSK	1	12	18.14	0	0
701.5	23035	5	QPSK	1	24	17.95	0	0
701.5	23035	5	QPSK	12	0	18.08	0	0-1
701.5	23035	5	QPSK	12	6	18.12	0	0-1
701.5	23035	5	QPSK	12	13	17.85	0	0-1
701.5	23035	5	QPSK	25	0	17.93	0	0-1
701.5	23035	5	16-QAM	1	0	18.13	0	0-1
701.5	23035	5	16-QAM	1	12	18.17	0	0-1
701.5	23035	5	16-QAM	1	24	17.98	0	0-1
701.5	23035	5	16-QAM	12	0	18.18	0	0-2
701.5	23035	5	16-QAM	12	6	18.09	0	0-2
701.5	23035	5	16-QAM	12	13	17.96	0	0-2
701.5	23035	5	16-QAM	25	0	17.92	0	0-2
707.5	23095	5	QPSK	1	0	18.05	0	0
707.5	23095	5	QPSK	1	12	18.06	0	0
707.5	23095	5	QPSK	1	24	17.97	0	0
707.5	23095	5	QPSK	12	0	18.12	0	0-1
707.5	23095	5	QPSK	12	6	18.07	0	0-1
707.5	23095	5	QPSK	12	13	18.04	0	0-1
707.5	23095	5	QPSK	25	0	18.06	0	0-1
707.5	23095	5	16-QAM	1	0	18.12	0	0-1
707.5	23095	5	16-QAM	1	12	18.19	0	0-1
707.5	23095	5	16-QAM	1	24	18.11	0	0-1
707.5	23095	5	16-QAM	12	0	18.10	0	0-2
707.5	23095	5	16-QAM	12	6	18.04	0	0-2
707.5	23095	5	16-QAM	12	13	18.07	0	0-2
707.5	23095	5	16-QAM	25	0	17.99	0	0-2
713.5	23155	5	QPSK	1	0	18.13	0	0
713.5	23155	5	QPSK	1	12	17.82	0	0
713.5	23155	5	QPSK	1	24	17.81	0	0
713.5	23155	5	QPSK	12	0	17.98	0	0-1
713.5	23155	5	QPSK	12	6	17.74	0	0-1
713.5	23155	5	QPSK	12	13	17.68	0	0-1
713.5	23155	5	QPSK	25	0	17.79	0	0-1
713.5	23155	5	16-QAM	1	0	18.10	0	0-1
713.5	23155	5	16-QAM	1	12	17.70	0	0-1
713.5	23155	5	16-QAM	1	24	17.64	0	0-1
713.5	23155	5	16-QAM	12	0	17.98	0	0-2
713.5	23155	5	16-QAM	12	6	17.78	0	0-2
713.5	23155	5	16-QAM	12	13	17.64	0	0-2
713.5	23155	5	16-QAM	25	0	17.71	0	0-2

**Table 10-9**  
**Reduced LTE Band 12 Conducted Powers Target 18 dBm – 3 MHz Bandwidth**

Frequency [MHz]	Channel	Bandwidth [MHz]	Modulation	RB Size	RB Offset	Conducted Power [dBm]	Target MPR [dB]	MPR Allowed per 3GPP [dB]
700.5	23025	3	QPSK	1	0	18.05	0	0
700.5	23025	3	QPSK	1	7	18.03	0	0
700.5	23025	3	QPSK	1	14	18.11	0	0
700.5	23025	3	QPSK	8	0	18.09	0	0-1
700.5	23025	3	QPSK	8	4	18.06	0	0-1
700.5	23025	3	QPSK	8	7	18.21	0	0-1
700.5	23025	3	QPSK	15	0	18.04	0	0-1
700.5	23025	3	16-QAM	1	0	18.12	0	0-1
700.5	23025	3	16-QAM	1	7	18.04	0	0-1
700.5	23025	3	16-QAM	1	14	18.13	0	0-1
700.5	23025	3	16-QAM	8	0	18.05	0	0-2
700.5	23025	3	16-QAM	8	4	17.97	0	0-2
700.5	23025	3	16-QAM	8	7	18.14	0	0-2
700.5	23025	3	16-QAM	15	0	18.04	0	0-2
707.5	23095	3	QPSK	1	0	18.13	0	0
707.5	23095	3	QPSK	1	7	18.11	0	0
707.5	23095	3	QPSK	1	14	18.12	0	0
707.5	23095	3	QPSK	8	0	18.08	0	0-1
707.5	23095	3	QPSK	8	4	18.08	0	0-1
707.5	23095	3	QPSK	8	7	18.05	0	0-1
707.5	23095	3	QPSK	15	0	18.00	0	0-1
707.5	23095	3	16-QAM	1	0	18.15	0	0-1
707.5	23095	3	16-QAM	1	7	18.11	0	0-1
707.5	23095	3	16-QAM	1	14	18.13	0	0-1
707.5	23095	3	16-QAM	8	0	18.03	0	0-2
707.5	23095	3	16-QAM	8	4	17.95	0	0-2
707.5	23095	3	16-QAM	8	7	17.98	0	0-2
707.5	23095	3	16-QAM	15	0	17.97	0	0-2
714.5	23165	3	QPSK	1	0	17.66	0	0
714.5	23165	3	QPSK	1	7	17.61	0	0
714.5	23165	3	QPSK	1	14	17.63	0	0
714.5	23165	3	QPSK	8	0	17.50	0	0-1
714.5	23165	3	QPSK	8	4	17.59	0	0-1
714.5	23165	3	QPSK	8	7	17.53	0	0-1
714.5	23165	3	QPSK	15	0	17.54	0	0-1
714.5	23165	3	16-QAM	1	0	17.65	0	0-1
714.5	23165	3	16-QAM	1	7	17.60	0	0-1
714.5	23165	3	16-QAM	1	14	17.63	0	0-1
714.5	23165	3	16-QAM	8	0	17.50	0	0-2
714.5	23165	3	16-QAM	8	4	17.51	0	0-2
714.5	23165	3	16-QAM	8	7	17.52	0	0-2
714.5	23165	3	16-QAM	15	0	17.56	0	0-2

**Table 10-10**

FCC ID: V65C6721A1		SAR EVALUATION REPORT		Reviewed by: Quality Manager
Document S/N: OY1212071742-R4.V65	Test Dates: 12/10/12 - 02/22/13	DUT Type: Portable Handset		Page 35 of 82

### Reduced LTE Band 12 Conducted Powers Target 18 dBm – 1.4 MHz Bandwidth

Frequency [MHz]	Channel	Bandwidth [MHz]	Modulation	RB Size	RB Offset	Conducted Power [dBm]	Target MPR [dB]	MPR Allowed per 3GPP [dB]
699.7	23017	1.4	QPSK	1	0	18.08	0	0
699.7	23017	1.4	QPSK	1	2	18.10	0	0
699.7	23017	1.4	QPSK	1	5	18.13	0	0
699.7	23017	1.4	QPSK	3	0	18.14	0	0
699.7	23017	1.4	QPSK	3	2	18.08	0	0
699.7	23017	1.4	QPSK	3	3	18.17	0	0
699.7	23017	1.4	QPSK	6	0	18.08	0	0-1
699.7	23017	1.4	16-QAM	1	0	18.06	0	0-1
699.7	23017	1.4	16-QAM	1	2	18.11	0	0-1
699.7	23017	1.4	16-QAM	1	5	18.12	0	0-1
699.7	23017	1.4	16-QAM	3	0	18.10	0	0-1
699.7	23017	1.4	16-QAM	3	2	18.08	0	0-1
699.7	23017	1.4	16-QAM	3	3	18.12	0	0-1
699.7	23017	1.4	16-QAM	6	0	18.03	0	0-2
707.5	23095	1.4	QPSK	1	0	18.15	0	0
707.5	23095	1.4	QPSK	1	2	18.19	0	0
707.5	23095	1.4	QPSK	1	5	18.16	0	0
707.5	23095	1.4	QPSK	3	0	18.16	0	0
707.5	23095	1.4	QPSK	3	2	18.13	0	0
707.5	23095	1.4	QPSK	3	3	18.12	0	0
707.5	23095	1.4	QPSK	6	0	18.10	0	0-1
707.5	23095	1.4	16-QAM	1	0	18.16	0	0-1
707.5	23095	1.4	16-QAM	1	2	18.23	0	0-1
707.5	23095	1.4	16-QAM	1	5	18.18	0	0-1
707.5	23095	1.4	16-QAM	3	0	18.17	0	0-1
707.5	23095	1.4	16-QAM	3	2	18.07	0	0-1
707.5	23095	1.4	16-QAM	3	3	18.11	0	0-1
707.5	23095	1.4	16-QAM	6	0	18.05	0	0-2
715.3	23173	1.4	QPSK	1	0	17.65	0	0
715.3	23173	1.4	QPSK	1	2	17.58	0	0
715.3	23173	1.4	QPSK	1	5	17.65	0	0
715.3	23173	1.4	QPSK	3	0	17.59	0	0
715.3	23173	1.4	QPSK	3	2	17.54	0	0
715.3	23173	1.4	QPSK	3	3	17.58	0	0
715.3	23173	1.4	QPSK	6	0	17.56	0	0-1
715.3	23173	1.4	16-QAM	1	0	17.58	0	0-1
715.3	23173	1.4	16-QAM	1	2	17.59	0	0-1
715.3	23173	1.4	16-QAM	1	5	17.62	0	0-1
715.3	23173	1.4	16-QAM	3	0	17.55	0	0-1
715.3	23173	1.4	16-QAM	3	2	17.59	0	0-1
715.3	23173	1.4	16-QAM	3	3	17.57	0	0-1
715.3	23173	1.4	16-QAM	6	0	17.50	0	0-2

### 10.3.2 Reduced LTE Band 17 Conducted Powers

Table 10-11  
Reduced LTE Band 17 Conducted Powers Target 19.5 dBm – 10 MHz Bandwidth

Frequency [MHz]	Channel	Bandwidth [MHz]	Modulation	RB Size	RB Offset	Conducted Power [dBm]	Target MPR [dB]	MPR Allowed per 3GPP [dB]
710.0	23790	10	QPSK	1	0	19.72	0	0
710.0	23790	10	QPSK	1	25	19.50	0	0
710.0	23790	10	QPSK	1	49	19.65	0	0
710.0	23790	10	QPSK	25	0	19.23	0	0-1
710.0	23790	10	QPSK	25	12	19.28	0	0-1
710.0	23790	10	QPSK	25	25	19.36	0	0-1
710.0	23790	10	QPSK	50	0	19.34	0	0-1
710.0	23790	10	16QAM	1	0	19.37	0	0-1
710.0	23790	10	16QAM	1	25	19.40	0	0-1
710.0	23790	10	16QAM	1	49	19.58	0	0-1
710.0	23790	10	16QAM	25	0	19.32	0	0-2
710.0	23790	10	16QAM	25	12	19.28	0	0-2
710.0	23790	10	16QAM	25	25	19.34	0	0-2
710.0	23790	10	16QAM	50	0	19.32	0	0-2

LTE Notes:



1. Please refer to Section 8.4.4 for LTE testing requirements per FCC KDB 941225 D05.
2. The bolded powers were tested for SAR.
3. LTE Band 17 at 10 MHz Bandwidth does not support three non-overlapping channels. Per KDB 941225 D05v02, when a device supports overlapping channel assignment in a channel bandwidth configuration, the mid channel of the group of overlapping channels should be selected for testing

Table 10-12  
Reduced LTE Band 17 Conducted Powers Target 19.5 dBm – 5 MHz Bandwidth

Frequency [MHz]	Channel	Bandwidth [MHz]	Modulation	RB Size	RB Offset	Conducted Power [dBm]	Target MPR [dB]	MPR Allowed per 3GPP [dB]
710.0	23790	5	QPSK	1	0	19.64	0	0
710.0	23790	5	QPSK	1	12	19.50	0	0
710.0	23790	5	QPSK	1	24	19.63	0	0
710.0	23790	5	QPSK	12	0	19.59	0	0-1
710.0	23790	5	QPSK	12	6	19.51	0	0-1
710.0	23790	5	QPSK	12	13	19.58	0	0-1
710.0	23790	5	QPSK	25	0	19.62	0	0-1
710.0	23790	5	16-QAM	1	0	19.29	0	0-1
710.0	23790	5	16-QAM	1	12	19.46	0	0-1
710.0	23790	5	16-QAM	1	24	19.56	0	0-1
710.0	23790	5	16-QAM	12	0	19.51	0	0-2
710.0	23790	5	16-QAM	12	6	19.50	0	0-2
710.0	23790	5	16-QAM	12	13	19.55	0	0-2
710.0	23790	5	16-QAM	25	0	19.62	0	0-2

Note: LTE Band 17 at 5 MHz Bandwidth does not support three non-overlapping channels. Per KDB 941225 D05v02, when a device supports overlapping channel assignment in a channel bandwidth configuration, the mid channel of the group of overlapping channels should be selected for testing

Table 10-13

FCC ID: V65C6721A1	 PCTEST ENGINEERING LABORATORY, INC.	SAR EVALUATION REPORT	 KYOCERA	Reviewed by: Quality Manager
Document S/N: OY1212071742-R4.V65	Test Dates: 12/10/12 - 02/22/13	DUT Type: Portable Handset	Page 36 of 82	

### Reduced LTE Band 17 Conducted Powers Target 18.5 dBm – 10 MHz Bandwidth

Frequency [MHz]	Channel	Bandwidth [MHz]	Modulation	RB Size	RB Offset	Conducted Power [dBm]	Target MPR [dB]	MPR Allowed per 3GPP [dB]
710.0	23790	10	QPSK	1	0	18.84	0	0
710.0	23790	10	QPSK	1	25	18.89	0	0
710.0	23790	10	QPSK	1	49	<b>18.98</b>	0	0
710.0	23790	10	QPSK	25	0	18.75	0	0-1
710.0	23790	10	QPSK	25	12	18.75	0	0-1
710.0	23790	10	QPSK	25	25	<b>18.87</b>	0	0-1
710.0	23790	10	QPSK	50	0	18.81	0	0-1
710.0	23790	10	16QAM	1	0	18.97	0	0-1
710.0	23790	10	16QAM	1	25	18.98	0	0-1
710.0	23790	10	16QAM	1	49	18.93	0	0-1
710.0	23790	10	16QAM	25	0	18.74	0	0-2
710.0	23790	10	16QAM	25	12	18.76	0	0-2
710.0	23790	10	16QAM	25	25	18.73	0	0-2
710.0	23790	10	16QAM	50	0	18.80	0	0-2

LTE Notes:

1. Please refer to Section 8.4.4 for LTE testing requirements per FCC KDB 941225 D05.
2. The bolded powers were tested for SAR.
3. LTE Band 17 at 10 MHz Bandwidth does not support three non-overlapping channels. Per KDB 941225 D05v02, when a device supports overlapping channel assignment in a channel bandwidth configuration, the mid channel of the group of overlapping channels should be selected for testing

**Table 10-14**  
Reduced LTE Band 17 Conducted Powers Target 18.5 dBm – 5 MHz Bandwidth

Frequency [MHz]	Channel	Bandwidth [MHz]	Modulation	RB Size	RB Offset	Conducted Power [dBm]	Target MPR [dB]	MPR Allowed per 3GPP [dB]
710.0	23790	5	QPSK	1	0	18.83	0	0
710.0	23790	5	QPSK	1	12	18.82	0	0
710.0	23790	5	QPSK	1	24	18.72	0	0
710.0	23790	5	QPSK	12	0	18.83	0	0-1
710.0	23790	5	QPSK	12	6	18.77	0	0-1
710.0	23790	5	QPSK	12	13	18.72	0	0-1
710.0	23790	5	QPSK	25	0	18.75	0	0-1
710.0	23790	5	16-QAM	1	0	18.73	0	0-1
710.0	23790	5	16-QAM	1	12	18.64	0	0-1
710.0	23790	5	16-QAM	1	24	18.78	0	0-1
710.0	23790	5	16-QAM	12	0	18.72	0	0-1
710.0	23790	5	16-QAM	12	6	18.65	0	0-2
710.0	23790	5	16-QAM	12	13	18.76	0	0-2
710.0	23790	5	16-QAM	25	0	18.72	0	0-2

LTE Band 17 at 5 MHz Bandwidth does not support three non-overlapping channels. Per KDB 941225 D05v02, when a device supports overlapping channel assignment in a channel bandwidth configuration, the mid channel of the group of overlapping channels should be selected for testing



### 10.3.3 Reduced LTE Band 5 Conducted Powers

**Table 10-15**  
Reduced LTE Band 5 Conducted Powers Target 19.5 dBm – 10 MHz Bandwidth

Frequency [MHz]	Channel	Bandwidth [MHz]	Modulation	RB Size	RB Offset	Conducted Power [dBm]	Target MPR [dB]	MPR Allowed per 3GPP [dB]
836.5	20525	10	QPSK	1	0	19.50	0	0
836.5	20525	10	QPSK	1	25	<b>19.64</b>	0	0
836.5	20525	10	QPSK	1	49	19.56	0	0
836.5	20525	10	QPSK	25	0	<b>19.40</b>	0	0-1
836.5	20525	10	QPSK	25	12	19.37	0	0-1
836.5	20525	10	QPSK	25	25	19.33	0	0-1
836.5	20525	10	QPSK	50	0	19.32	0	0-1
836.5	20525	10	16QAM	1	0	19.39	0	0-1
836.5	20525	10	16QAM	1	25	19.62	0	0-1
836.5	20525	10	16QAM	1	49	19.50	0	0-1
836.5	20525	10	16QAM	25	0	19.34	0	0-2
836.5	20525	10	16QAM	25	12	19.44	0	0-2
836.5	20525	10	16QAM	25	25	19.27	0	0-2
836.5	20525	10	16QAM	50	0	19.28	0	0-2

LTE Notes:

4. Please refer to Section 8.4.4 for LTE testing requirements per FCC KDB 941225 D05.
5. The bolded powers were tested for SAR.
6. LTE Band 5 at 10 MHz Bandwidth does not support three non-overlapping channels. Per KDB 941225 D05v02, when a device supports overlapping channel assignment in a channel bandwidth configuration, the mid channel of the group of overlapping channels should be selected for testing

FCC ID: V65C6721A1	 PCTEST ENGINEERING LABORATORY, INC.	SAR EVALUATION REPORT	 KYOCERA	Reviewed by: Quality Manager
Document S/N: 0Y1212071742-R4.V65	Test Dates: 12/10/12 - 02/22/13	DUT Type: Portable Handset	Page 37 of 82	



**Table 10-16**  
**Reduced LTE Band 5 Conducted Powers Target 19.5 dBm – 5 MHz Bandwidth**

Frequency [MHz]	Channel	Bandwidth [MHz]	Modulation	RB Size	RB Offset	Conducted Power [dBm]	Target MPR [dB]	MPR Allowed per 3GPP [dB]
825.5	20425	5	QPSK	1	0	19.56	0	0
825.5	20425	5	QPSK	1	12	19.72	0	0
825.5	20425	5	QPSK	1	24	19.64	0	0
825.5	20425	5	QPSK	12	0	19.46	0	-1
825.5	20425	5	QPSK	12	6	19.43	0	-1
825.5	20425	5	QPSK	12	13	19.41	0	-1
825.5	20425	5	QPSK	25	0	19.38	0	-1
825.5	20425	5	16-QAM	1	0	19.47	0	-1
825.5	20425	5	16-QAM	1	12	19.68	0	-1
825.5	20425	5	16-QAM	1	24	19.54	0	-1
825.5	20425	5	16-QAM	12	0	19.42	0	-1
825.5	20425	5	16-QAM	12	6	19.50	0	-1
825.5	20425	5	16-QAM	12	13	19.33	0	-1
825.5	20425	5	16-QAM	25	0	19.34	0	-1
836.5	20525	5	QPSK	1	0	19.53	0	0
836.5	20525	5	QPSK	1	12	19.66	0	0
836.5	20525	5	QPSK	1	24	19.51	0	0
836.5	20525	5	QPSK	12	0	19.48	0	-1
836.5	20525	5	QPSK	12	6	19.45	0	-1
836.5	20525	5	QPSK	12	13	19.59	0	-1
836.5	20525	5	QPSK	25	0	19.47	0	-1
836.5	20525	5	16-QAM	1	0	19.73	0	-1
836.5	20525	5	16-QAM	1	12	19.64	0	-1
836.5	20525	5	16-QAM	1	24	19.51	0	-1
836.5	20525	5	16-QAM	12	0	19.47	0	-1
836.5	20525	5	16-QAM	12	6	19.54	0	-1
836.5	20525	5	16-QAM	12	13	19.42	0	-1
836.5	20525	5	16-QAM	25	0	19.38	0	-1
846.5	20625	5	QPSK	1	0	19.50	0	0
846.5	20625	5	QPSK	1	12	19.64	0	0
846.5	20625	5	QPSK	1	24	19.56	0	0
846.5	20625	5	QPSK	12	0	19.42	0	-1
846.5	20625	5	QPSK	12	6	19.39	0	-1
846.5	20625	5	QPSK	12	13	19.35	0	-1
846.5	20625	5	QPSK	25	0	19.32	0	-1
846.5	20625	5	16-QAM	1	0	19.41	0	-1
846.5	20625	5	16-QAM	1	12	19.62	0	-1
846.5	20625	5	16-QAM	1	24	19.52	0	-1
846.5	20625	5	16-QAM	12	0	19.34	0	-1
846.5	20625	5	16-QAM	12	6	19.46	0	-1
846.5	20625	5	16-QAM	12	13	19.27	0	-1
846.5	20625	5	16-QAM	25	0	19.30	0	-1

**Table 10-17**  
**Reduced LTE Band 5 Conducted Powers Target 19.5 dBm – 3 MHz Bandwidth**

Frequency [MHz]	Channel	Bandwidth [MHz]	Modulation	RB Size	RB Offset	Conducted Power [dBm]	Target MPR [dB]	MPR Allowed per 3GPP [dB]
825.5	20415	3	QPSK	1	0	19.57	0	0
825.5	20415	3	QPSK	1	7	19.67	0	0
825.5	20415	3	QPSK	1	14	19.65	0	0
825.5	20415	3	QPSK	8	0	19.49	0	-1
825.5	20415	3	QPSK	8	4	19.35	0	-1
825.5	20415	3	QPSK	8	7	19.35	0	-1
825.5	20415	3	QPSK	15	0	19.39	0	-1
825.5	20415	3	16-QAM	1	0	19.50	0	-1
825.5	20415	3	16-QAM	1	7	19.60	0	-1
825.5	20415	3	16-QAM	1	14	19.57	0	-1
825.5	20415	3	16-QAM	8	0	19.43	0	-1
825.5	20415	3	16-QAM	8	4	19.44	0	-1
825.5	20415	3	16-QAM	8	7	19.25	0	-1
825.5	20415	3	16-QAM	15	0	19.37	0	-1
836.5	20525	3	QPSK	1	0	19.52	0	0
836.5	20525	3	QPSK	1	7	19.58	0	0
836.5	20525	3	QPSK	1	14	19.55	0	0
836.5	20525	3	QPSK	8	0	19.44	0	-1
836.5	20525	3	QPSK	8	4	19.50	0	-1
836.5	20525	3	QPSK	8	7	19.43	0	-1
836.5	20525	3	QPSK	15	0	19.44	0	-1
836.5	20525	3	16-QAM	1	0	19.51	0	-1
836.5	20525	3	16-QAM	1	7	19.69	0	-1
836.5	20525	3	16-QAM	1	14	19.60	0	-1
836.5	20525	3	16-QAM	8	0	19.40	0	-1
836.5	20525	3	16-QAM	8	4	19.59	0	-1
836.5	20525	3	16-QAM	8	7	19.49	0	-1
836.5	20525	3	16-QAM	15	0	19.41	0	-1
847.5	20635	3	QPSK	1	0	19.42	0	0
847.5	20635	3	QPSK	1	7	19.65	0	0
847.5	20635	3	QPSK	1	14	19.59	0	0
847.5	20635	3	QPSK	8	0	19.36	0	-1
847.5	20635	3	QPSK	8	4	19.40	0	-1
847.5	20635	3	QPSK	8	7	19.29	0	-1
847.5	20635	3	QPSK	15	0	19.24	0	-1
847.5	20635	3	16-QAM	1	0	19.43	0	-1
847.5	20635	3	16-QAM	1	7	19.65	0	-1
847.5	20635	3	16-QAM	1	14	19.44	0	-1
847.5	20635	3	16-QAM	8	0	19.28	0	-1
847.5	20635	3	16-QAM	8	4	19.49	0	-1
847.5	20635	3	16-QAM	8	7	19.19	0	-1
847.5	20635	3	16-QAM	15	0	19.33	0	-1

**Table 10-18**

FCC ID: V65C6721A1		<b>SAR EVALUATION REPORT</b>		Reviewed by: Quality Manager
Document S/N: OY1212071742-R4.V65	Test Dates: 12/10/12 - 02/22/13	DUT Type: Portable Handset		Page 38 of 82

### Reduced LTE Band 5 Conducted Powers Target 19.5 dBm – 1.4 MHz Bandwidth



Frequency [MHz]	Channel	Bandwidth [MHz]	Modulation	RB Size	RB Offset	Conducted Power [dBm]	Target MPR [dB]	MPR Allowed per 3GPP [dB]
824.7	20407	1.4	QPSK	1	0	19.54	0	0
824.7	20407	1.4	QPSK	1	2	19.71	0	0
824.7	20407	1.4	QPSK	1	5	19.62	0	0
824.7	20407	1.4	QPSK	3	0	19.45	0	0
824.7	20407	1.4	QPSK	3	2	19.41	0	0
824.7	20407	1.4	QPSK	3	3	19.40	0	0
824.7	20407	1.4	QPSK	6	0	19.36	0	0-1
824.7	20407	1.4	16-QAM	1	0	19.46	0	0-1
824.7	20407	1.4	16-QAM	1	2	19.66	0	0-1
824.7	20407	1.4	16-QAM	1	5	19.53	0	0-1
824.7	20407	1.4	16-QAM	3	0	19.40	0	0-1
824.7	20407	1.4	16-QAM	3	2	19.49	0	0-1
824.7	20407	1.4	16-QAM	3	3	19.31	0	0-1
824.7	20407	1.4	16-QAM	6	0	19.33	0	0-2
836.5	20525	1.4	QPSK	1	0	19.51	0	0
836.5	20525	1.4	QPSK	1	2	19.65	0	0
836.5	20525	1.4	QPSK	1	5	19.49	0	0
836.5	20525	1.4	QPSK	3	0	19.47	0	0
836.5	20525	1.4	QPSK	3	2	19.43	0	0
836.5	20525	1.4	QPSK	3	3	19.58	0	0
836.5	20525	1.4	QPSK	6	0	19.45	0	0-1
836.5	20525	1.4	16-QAM	1	0	19.72	0	0-1
836.5	20525	1.4	16-QAM	1	2	19.62	0	0-1
836.5	20525	1.4	16-QAM	1	5	19.50	0	0-1
836.5	20525	1.4	16-QAM	3	0	19.45	0	0-1
836.5	20525	1.4	16-QAM	3	2	19.53	0	0-1
836.5	20525	1.4	16-QAM	3	3	19.40	0	0-1
836.5	20525	1.4	16-QAM	6	0	19.37	0	0-2
848.3	20643	1.4	QPSK	1	0	19.48	0	0
848.3	20643	1.4	QPSK	1	2	19.63	0	0
848.3	20643	1.4	QPSK	1	5	19.54	0	0
848.3	20643	1.4	QPSK	3	0	19.41	0	0
848.3	20643	1.4	QPSK	3	2	19.37	0	0
848.3	20643	1.4	QPSK	3	3	19.34	0	0
848.3	20643	1.4	QPSK	6	0	19.30	0	0-1
848.3	20643	1.4	16-QAM	1	0	19.40	0	0-1
848.3	20643	1.4	16-QAM	1	2	19.60	0	0-1
848.3	20643	1.4	16-QAM	1	5	19.51	0	0-1
848.3	20643	1.4	16-QAM	3	0	19.32	0	0-1
848.3	20643	1.4	16-QAM	3	2	19.45	0	0-1
848.3	20643	1.4	16-QAM	3	3	19.25	0	0-1
848.3	20643	1.4	16-QAM	6	0	19.29	0	0-2

**Table 10-19**  
**Reduced LTE Band 5 Conducted Powers Target 18 dBm – 10 MHz Bandwidth**

Frequency [MHz]	Channel	Bandwidth [MHz]	Modulation	RB Size	RB Offset	Conducted Power [dBm]	Target MPR [dB]	MPR Allowed per 3GPP [dB]
836.5	20525	10	QPSK	1	0	17.78	0	0
836.5	20525	10	QPSK	1	25	<b>17.98</b>	0	0
836.5	20525	10	QPSK	1	49	17.86	0	0
836.5	20525	10	QPSK	25	0	17.80	0	0-1
836.5	20525	10	QPSK	25	12	<b>17.92</b>	0	0-1
836.5	20525	10	QPSK	25	25	17.82	0	0-1
836.5	20525	10	QPSK	50	0	17.77	0	0-1
836.5	20525	10	16QAM	1	0	17.93	0	0-1
836.5	20525	10	16QAM	1	25	18.04	0	0-1
836.5	20525	10	16QAM	1	49	18.02	0	0-1
836.5	20525	10	16QAM	25	0	17.82	0	0-2
836.5	20525	10	16QAM	25	12	17.89	0	0-2
836.5	20525	10	16QAM	25	25	17.85	0	0-2
836.5	20525	10	16QAM	50	0	17.78	0	0-2

**LTE Notes:**

1. Please refer to Section 8.4.4 for LTE testing requirements per FCC KDB 941225 D05.
2. The bolded powers were tested for SAR.
3. LTE Band 5 at 10 MHz Bandwidth does not support three non-overlapping channels. Per KDB 941225 D05v02, when a device supports overlapping channel assignment in a channel bandwidth configuration, the mid channel of the group of overlapping channels should be selected for testing

FCC ID: V65C6721A1	 <b>PCTEST</b> ENGINEERING LABORATORY, INC.	<b>SAR EVALUATION REPORT</b>	 <b>KYOCERA</b>	Reviewed by: Quality Manager
Document S/N: 0Y1212071742-R4.V65	Test Dates: 12/10/12 - 02/22/13	DUT Type: Portable Handset		Page 39 of 82



**Table 10-20**  
**Reduced LTE Band 5 Conducted Powers Target 18 dBm – 5 MHz Bandwidth**

Frequency [MHz]	Channel	Bandwidth [MHz]	Modulation	RB Size	RB Offset	Conducted Power [dBm]	Target MPR [dB]	MPR Allowed per 3GPP [dB]
826.5	20425	5	QPSK	1	0	17.76	0	0
826.5	20425	5	QPSK	1	12	17.94	0	0
826.5	20425	5	QPSK	1	24	17.84	0	0
826.5	20425	5	QPSK	12	0	17.76	0	0-1
826.5	20425	5	QPSK	12	6	17.90	0	0-1
826.5	20425	5	QPSK	12	13	17.78	0	0-1
826.5	20425	5	QPSK	25	0	17.75	0	0-1
826.5	20425	5	16-QAM	1	0	17.89	0	0-1
826.5	20425	5	16-QAM	1	12	18.02	0	0-1
826.5	20425	5	16-QAM	1	24	17.98	0	0-1
826.5	20425	5	16-QAM	12	0	17.80	0	0-2
826.5	20425	5	16-QAM	12	6	17.85	0	0-2
826.5	20425	5	16-QAM	12	13	17.83	0	0-2
826.5	20425	5	16-QAM	25	0	17.74	0	0-2
836.5	20525	5	QPSK	1	0	17.98	0	0
836.5	20525	5	QPSK	1	12	18.17	0	0
836.5	20525	5	QPSK	1	24	18.05	0	0
836.5	20525	5	QPSK	12	0	18.00	0	0-1
836.5	20525	5	QPSK	12	6	18.11	0	0-1
836.5	20525	5	QPSK	12	13	17.92	0	0-1
836.5	20525	5	QPSK	25	0	17.95	0	0-1
836.5	20525	5	16-QAM	1	0	18.42	0	0-1
836.5	20525	5	16-QAM	1	12	18.18	0	0-1
836.5	20525	5	16-QAM	1	24	18.07	0	0-1
836.5	20525	5	16-QAM	12	0	18.02	0	0-2
836.5	20525	5	16-QAM	12	6	18.09	0	0-2
836.5	20525	5	16-QAM	12	13	18.03	0	0-2
836.5	20525	5	16-QAM	25	0	17.93	0	0-2
846.5	20625	5	QPSK	1	0	17.82	0	0
846.5	20625	5	QPSK	1	12	18.00	0	0
846.5	20625	5	QPSK	1	24	17.90	0	0
846.5	20625	5	QPSK	12	0	17.82	0	0-1
846.5	20625	5	QPSK	12	6	17.96	0	0-1
846.5	20625	5	QPSK	12	13	17.84	0	0-1
846.5	20625	5	QPSK	25	0	17.81	0	0-1
846.5	20625	5	16-QAM	1	0	17.95	0	0-1
846.5	20625	5	16-QAM	1	12	18.08	0	0-1
846.5	20625	5	16-QAM	1	24	18.04	0	0-1
846.5	20625	5	16-QAM	12	0	17.86	0	0-2
846.5	20625	5	16-QAM	12	6	17.91	0	0-2
846.5	20625	5	16-QAM	12	13	17.89	0	0-2
846.5	20625	5	16-QAM	25	0	17.80	0	0-2

**Table 10-21**  
**Reduced LTE Band 5 Conducted Powers Target 18 dBm – 3 MHz Bandwidth**

Frequency [MHz]	Channel	Bandwidth [MHz]	Modulation	RB Size	RB Offset	Conducted Power [dBm]	Target MPR [dB]	MPR Allowed per 3GPP [dB]
825.5	20415	3	QPSK	1	0	17.78	0	0
825.5	20415	3	QPSK	1	7	17.98	0	0
825.5	20415	3	QPSK	1	14	17.86	0	0
825.5	20415	3	QPSK	8	0	17.80	0	0-1
825.5	20415	3	QPSK	8	4	17.92	0	0-1
825.5	20415	3	QPSK	8	7	17.82	0	0-1
825.5	20415	3	QPSK	15	0	17.79	0	0-1
825.5	20415	3	16-QAM	1	0	17.91	0	0-1
825.5	20415	3	16-QAM	1	7	18.04	0	0-1
825.5	20415	3	16-QAM	1	14	18.02	0	0-1
825.5	20415	3	16-QAM	8	0	17.84	0	0-2
825.5	20415	3	16-QAM	8	4	17.87	0	0-2
825.5	20415	3	16-QAM	8	7	17.85	0	0-2
825.5	20415	3	16-QAM	15	0	17.78	0	0-2
836.5	20525	3	QPSK	1	0	17.89	0	0
836.5	20525	3	QPSK	1	7	18.18	0	0
836.5	20525	3	QPSK	1	14	18.04	0	0
836.5	20525	3	QPSK	8	0	18.06	0	0-1
836.5	20525	3	QPSK	8	4	18.02	0	0-1
836.5	20525	3	QPSK	8	7	17.97	0	0-1
836.5	20525	3	QPSK	15	0	17.89	0	0-1
836.5	20525	3	16-QAM	1	0	18.16	0	0-1
836.5	20525	3	16-QAM	1	7	18.15	0	0-1
836.5	20525	3	16-QAM	1	14	18.05	0	0-1
836.5	20525	3	16-QAM	8	0	17.98	0	0-2
836.5	20525	3	16-QAM	8	4	18.08	0	0-2
836.5	20525	3	16-QAM	8	7	18.01	0	0-2
836.5	20525	3	16-QAM	15	0	17.96	0	0-2
847.5	20635	3	QPSK	1	0	17.78	0	0
847.5	20635	3	QPSK	1	7	17.98	0	0
847.5	20635	3	QPSK	1	14	17.86	0	0
847.5	20635	3	QPSK	8	0	17.80	0	0-1
847.5	20635	3	QPSK	8	4	17.92	0	0-1
847.5	20635	3	QPSK	8	7	17.82	0	0-1
847.5	20635	3	QPSK	15	0	17.77	0	0-1
847.5	20635	3	16-QAM	1	0	17.93	0	0-1
847.5	20635	3	16-QAM	1	7	18.04	0	0-1
847.5	20635	3	16-QAM	1	14	18.02	0	0-1
847.5	20635	3	16-QAM	8	0	17.82	0	0-2
847.5	20635	3	16-QAM	8	4	17.89	0	0-2
847.5	20635	3	16-QAM	8	7	17.85	0	0-2
847.5	20635	3	16-QAM	15	0	17.78	0	0-2

**Table 10-22**

FCC ID: V65C6721A1		SAR EVALUATION REPORT		Reviewed by: Quality Manager
Document S/N: OY1212071742-R4.V65	Test Dates: 12/10/12 - 02/22/13	DUT Type: Portable Handset		Page 40 of 82



## Reduced LTE Band 5 Conducted Powers Target 18 dBm – 1.4 MHz Bandwidth

Frequency [MHz]	Channel	Bandwidth [MHz]	Modulation	RB Size	RB Offset	Conducted Power [dBm]	Target MPR [dB]	MPR Allowed per 3GPP [dB]
824.7	20407	1.4	QPSK	1	0	17.77	0	0
824.7	20407	1.4	QPSK	1	2	17.83	0	0
824.7	20407	1.4	QPSK	1	5	17.85	0	0
824.7	20407	1.4	QPSK	3	0	17.75	0	0
824.7	20407	1.4	QPSK	3	2	17.91	0	0
824.7	20407	1.4	QPSK	3	3	17.77	0	0
824.7	20407	1.4	QPSK	6	0	17.76	0	0-1
824.7	20407	1.4	16-QAM	1	0	17.88	0	0-1
824.7	20407	1.4	16-QAM	1	2	18.03	0	0-1
824.7	20407	1.4	16-QAM	1	5	17.97	0	0-1
824.7	20407	1.4	16-QAM	3	0	17.81	0	0-1
824.7	20407	1.4	16-QAM	3	2	17.84	0	0-1
824.7	20407	1.4	16-QAM	3	3	17.83	0	0-1
824.7	20407	1.4	16-QAM	6	0	17.73	0	0-2
836.5	20525	1.4	QPSK	1	0	17.99	0	0
836.5	20525	1.4	QPSK	1	2	18.06	0	0
836.5	20525	1.4	QPSK	1	5	17.96	0	0
836.5	20525	1.4	QPSK	3	0	17.88	0	0
836.5	20525	1.4	QPSK	3	2	17.87	0	0
836.5	20525	1.4	QPSK	3	3	17.91	0	0
836.5	20525	1.4	QPSK	6	0	17.93	0	0-1
836.5	20525	1.4	16-QAM	1	0	18.14	0	0-1
836.5	20525	1.4	16-QAM	1	2	18.19	0	0-1
836.5	20525	1.4	16-QAM	1	5	18.01	0	0-1
836.5	20525	1.4	16-QAM	3	0	17.93	0	0-1
836.5	20525	1.4	16-QAM	3	2	17.88	0	0-1
836.5	20525	1.4	16-QAM	3	3	17.84	0	0-1
836.5	20525	1.4	16-QAM	6	0	17.92	0	0-2
848.3	20643	1.4	QPSK	1	0	17.82	0	0
848.3	20643	1.4	QPSK	1	2	17.97	0	0
848.3	20643	1.4	QPSK	1	5	17.91	0	0
848.3	20643	1.4	QPSK	3	0	17.91	0	0
848.3	20643	1.4	QPSK	3	2	17.95	0	0
848.3	20643	1.4	QPSK	3	3	17.93	0	0
848.3	20643	1.4	QPSK	6	0	17.82	0	0-1
848.3	20643	1.4	16-QAM	1	0	17.95	0	0-1
848.3	20643	1.4	16-QAM	1	2	18.02	0	0-1
848.3	20643	1.4	16-QAM	1	5	18.00	0	0-1
848.3	20643	1.4	16-QAM	3	0	17.87	0	0-1
848.3	20643	1.4	16-QAM	3	2	17.77	0	0-1
848.3	20643	1.4	16-QAM	3	3	17.91	0	0-1
848.3	20643	1.4	16-QAM	6	0	17.79	0	0-2

## 10.3.4 Reduced LTE Band 4 Conducted Powers

Table 10-23



### Reduced LTE Band 4 Conducted Powers Target 19 dBm – 10 MHz Bandwidth

Frequency [MHz]	Channel	Bandwidth [MHz]	Modulation	RB Size	RB Offset	Conducted Power [dBm]	Target MPR [dB]	MPR Allowed per 3GPP [dB]
1715	20000	10	QPSK	1	0	18.74	0	0
1715	20000	10	QPSK	1	25	18.83	0	0
1715	20000	10	QPSK	1	49	18.68	0	0
1715	20000	10	QPSK	25	0	18.65	0	0-1
1715	20000	10	QPSK	25	12	18.70	0	0-1
1715	20000	10	QPSK	25	25	18.62	0	0-1
1715	20000	10	QPSK	50	0	18.58	0	0-1
1715	20000	10	16QAM	1	0	18.76	0	0-1
1715	20000	10	16QAM	1	25	18.83	0	0-1
1715	20000	10	16QAM	1	49	18.64	0	0-1
1715	20000	10	16QAM	25	0	18.59	0	0-2
1715	20000	10	16QAM	25	12	18.61	0	0-2
1715	20000	10	16QAM	25	25	18.62	0	0-2
1715	20000	10	16QAM	50	0	18.58	0	0-2
1732.5	20175	10	QPSK	1	0	18.77	0	0
1732.5	20175	10	QPSK	1	25	18.69	0	0
1732.5	20175	10	QPSK	1	49	18.56	0	0
1732.5	20175	10	QPSK	25	0	18.57	0	0-1
1732.5	20175	10	QPSK	25	12	18.63	0	0-1
1732.5	20175	10	QPSK	25	25	18.66	0	0-1
1732.5	20175	10	QPSK	50	0	18.52	0	0-1
1732.5	20175	10	16QAM	1	0	18.76	0	0-1
1732.5	20175	10	16QAM	1	25	18.78	0	0-1
1732.5	20175	10	16QAM	1	49	18.53	0	0-1
1732.5	20175	10	16QAM	25	0	18.62	0	0-2
1732.5	20175	10	16QAM	25	12	18.58	0	0-2
1732.5	20175	10	16QAM	25	25	18.67	0	0-2
1732.5	20175	10	16QAM	50	0	18.50	0	0-2
1750	20350	10	QPSK	1	0	18.87	0	0
1750	20350	10	QPSK	1	25	<b>18.88</b>	0	0
1750	20350	10	QPSK	1	49	18.77	0	0
1750	20350	10	QPSK	25	0	<b>18.82</b>	0	0-1
1750	20350	10	QPSK	25	12	18.67	0	0-1
1750	20350	10	QPSK	25	25	18.68	0	0-1
1750	20350	10	QPSK	50	0	18.65	0	0-1
1750	20350	10	16QAM	1	0	18.92	0	0-1
1750	20350	10	16QAM	1	25	18.89	0	0-1
1750	20350	10	16QAM	1	49	18.74	0	0-1
1750	20350	10	16QAM	25	0	18.80	0	0-2
1750	20350	10	16QAM	25	12	18.62	0	0-2
1750	20350	10	16QAM	25	25	18.64	0	0-2
1750	20350	10	16QAM	50	0	18.60	0	0-2

LTE Notes:

4. Please refer to Section 8.4.4 for LTE testing requirements per FCC KDB 941225 D05.
5. The bolded powers were tested for SAR.

Table 10-24

FCC ID: V65C6721A1		SAR EVALUATION REPORT		Reviewed by: Quality Manager
Document S/N: 0Y1212071742-R4.V65	Test Dates: 12/10/12 - 02/22/13	DUT Type: Portable Handset		Page 41 of 82

### Reduced LTE Band 4 Conducted Powers Target 19 dBm – 5 MHz Bandwidth

Frequency [MHz]	Channel	Bandwidth [MHz]	Modulation	RB Size	RB Offset	Conducted Power [dBm]	Target MPR [dB]	MPR Allowed per 3GPP [dB]
1712.5	19975	5	QPSK	1	0	18.78	0	0
1712.5	19975	5	QPSK	1	12	19.09	0	0
1712.5	19975	5	QPSK	1	24	19.03	0	0
1712.5	19975	5	QPSK	12	0	18.96	0	0-1
1712.5	19975	5	QPSK	12	6	18.91	0	0-1
1712.5	19975	5	QPSK	12	13	18.95	0	0-1
1712.5	19975	5	QPSK	25	0	18.88	0	0-1
1712.5	19975	5	16-QAM	1	0	18.55	0	0-1
1712.5	19975	5	16-QAM	1	12	18.63	0	0-1
1712.5	19975	5	16-QAM	1	24	19.09	0	0-1
1712.5	19975	5	16-QAM	12	0	18.90	0	0-2
1712.5	19975	5	16-QAM	12	6	18.89	0	0-2
1712.5	19975	5	16-QAM	12	13	19.04	0	0-2
1712.5	19975	5	16-QAM	25	0	18.83	0	0-2
1732.5	20175	5	QPSK	1	0	19.03	0	0
1732.5	20175	5	QPSK	1	12	19.08	0	0
1732.5	20175	5	QPSK	1	24	19.06	0	0
1732.5	20175	5	QPSK	12	0	18.93	0	0-1
1732.5	20175	5	QPSK	12	6	18.93	0	0-1
1732.5	20175	5	QPSK	12	13	19.16	0	0-1
1732.5	20175	5	QPSK	25	0	18.96	0	0-1
1732.5	20175	5	16-QAM	1	0	18.91	0	0-1
1732.5	20175	5	16-QAM	1	12	19.02	0	0-1
1732.5	20175	5	16-QAM	1	24	19.05	0	0-1
1732.5	20175	5	16-QAM	12	0	18.96	0	0-2
1732.5	20175	5	16-QAM	12	6	18.96	0	0-2
1732.5	20175	5	16-QAM	12	13	19.13	0	0-2
1732.5	20175	5	16-QAM	25	0	18.82	0	0-2
1752.5	20375	5	QPSK	1	0	19.00	0	0
1752.5	20375	5	QPSK	1	12	19.01	0	0
1752.5	20375	5	QPSK	1	24	18.91	0	0
1752.5	20375	5	QPSK	12	0	18.93	0	0-1
1752.5	20375	5	QPSK	12	6	18.81	0	0-1
1752.5	20375	5	QPSK	12	13	18.83	0	0-1
1752.5	20375	5	QPSK	25	0	18.78	0	0-1
1752.5	20375	5	16-QAM	1	0	19.01	0	0-1
1752.5	20375	5	16-QAM	1	12	18.99	0	0-1
1752.5	20375	5	16-QAM	1	24	18.87	0	0-1
1752.5	20375	5	16-QAM	12	0	18.93	0	0-2
1752.5	20375	5	16-QAM	12	6	18.76	0	0-2
1752.5	20375	5	16-QAM	12	13	18.87	0	0-2
1752.5	20375	5	16-QAM	25	0	18.73	0	0-2



Table 10-25

### Reduced LTE Band 4 Conducted Powers Target 19 dBm – 3 MHz Bandwidth

Frequency [MHz]	Channel	Bandwidth [MHz]	Modulation	RB Size	RB Offset	Conducted Power [dBm]	Target MPR [dB]	MPR Allowed per 3GPP [dB]
1711.5	19965	3	QPSK	1	0	18.81	0	0
1711.5	19965	3	QPSK	1	7	19.10	0	0
1711.5	19965	3	QPSK	1	14	19.01	0	0
1711.5	19965	3	QPSK	8	0	19.00	0	0-1
1711.5	19965	3	QPSK	8	4	18.95	0	0-1
1711.5	19965	3	QPSK	8	7	18.99	0	0-1
1711.5	19965	3	QPSK	15	0	18.57	0	0-1
1711.5	19965	3	16-QAM	1	0	18.65	0	0-1
1711.5	19965	3	16-QAM	1	7	19.11	0	0-1
1711.5	19965	3	16-QAM	1	14	18.95	0	0-1
1711.5	19965	3	16-QAM	8	0	18.90	0	0-2
1711.5	19965	3	16-QAM	8	4	19.01	0	0-2
1711.5	19965	3	16-QAM	8	7	18.86	0	0-2
1711.5	19965	3	16-QAM	15	0	18.83	0	0-2
1732.5	20175	3	QPSK	1	0	19.07	0	0
1732.5	20175	3	QPSK	1	7	19.12	0	0
1732.5	20175	3	QPSK	1	14	19.05	0	0
1732.5	20175	3	QPSK	8	0	18.95	0	0-1
1732.5	20175	3	QPSK	8	4	18.96	0	0-1
1732.5	20175	3	QPSK	8	7	19.18	0	0-1
1732.5	20175	3	QPSK	15	0	18.96	0	0-1
1732.5	20175	3	16-QAM	1	0	18.95	0	0-1
1732.5	20175	3	16-QAM	1	7	19.06	0	0-1
1732.5	20175	3	16-QAM	1	14	19.09	0	0-1
1732.5	20175	3	16-QAM	8	0	18.97	0	0-2
1732.5	20175	3	16-QAM	8	4	18.98	0	0-2
1732.5	20175	3	16-QAM	8	7	19.14	0	0-2
1732.5	20175	3	16-QAM	15	0	18.86	0	0-2
1753.5	20385	3	QPSK	1	0	19.03	0	0
1753.5	20385	3	QPSK	1	7	18.95	0	0
1753.5	20385	3	QPSK	1	14	18.93	0	0
1753.5	20385	3	QPSK	8	0	18.94	0	0-1
1753.5	20385	3	QPSK	8	4	18.83	0	0-1
1753.5	20385	3	QPSK	8	7	18.87	0	0-1
1753.5	20385	3	QPSK	15	0	18.81	0	0-1
1753.5	20385	3	16-QAM	1	0	18.99	0	0-1
1753.5	20385	3	16-QAM	1	7	19.00	0	0-1
1753.5	20385	3	16-QAM	1	14	18.89	0	0-1
1753.5	20385	3	16-QAM	8	0	18.97	0	0-2
1753.5	20385	3	16-QAM	8	4	18.80	0	0-2
1753.5	20385	3	16-QAM	8	7	18.91	0	0-2
1753.5	20385	3	16-QAM	15	0	18.75	0	0-2

Table 10-26

### Reduced LTE Band 4 Conducted Powers Target 19 dBm – 1.4 MHz Bandwidth

FCC ID: V65C6721A1	 PCTEST ENGINEERING LABORATORY, INC.	SAR EVALUATION REPORT	 KYOCERA	Reviewed by: Quality Manager
Document S/N: OY1212071742-R4.V65	Test Dates: 12/10/12 - 02/22/13	DUT Type: Portable Handset		Page 42 of 82

Frequency [MHz]	Channel	Bandwidth [MHz]	Modulation	RB Size	RB Offset	Conducted Power [dBm]	Target MPR [dB]	MPR Allowed per 3GPP [dB]
1710.7	19957	1.4	QPSK	1	0	18.80	0	0
1710.7	19957	1.4	QPSK	1	2	19.04	0	0
1710.7	19957	1.4	QPSK	1	5	18.95	0	0
1710.7	19957	1.4	QPSK	3	0	18.94	0	0
1710.7	19957	1.4	QPSK	3	2	18.93	0	0
1710.7	19957	1.4	QPSK	3	3	18.98	0	0
1710.7	19957	1.4	QPSK	6	0	18.85	0	0-1
1710.7	19957	1.4	16-QAM	1	0	18.80	0	0-1
1710.7	19957	1.4	16-QAM	1	2	19.10	0	0-1
1710.7	19957	1.4	16-QAM	1	5	18.95	0	0-1
1710.7	19957	1.4	16-QAM	3	0	18.85	0	0-1
1710.7	19957	1.4	16-QAM	3	2	18.96	0	0-1
1710.7	19957	1.4	16-QAM	3	3	18.84	0	0-1
1710.7	19957	1.4	16-QAM	6	0	18.81	0	0-2
1732.5	20175	1.4	QPSK	1	0	19.00	0	0
1732.5	20175	1.4	QPSK	1	2	19.05	0	0
1732.5	20175	1.4	QPSK	1	5	18.84	0	0
1732.5	20175	1.4	QPSK	3	0	18.89	0	0
1732.5	20175	1.4	QPSK	3	2	18.90	0	0
1732.5	20175	1.4	QPSK	3	3	19.07	0	0
1732.5	20175	1.4	QPSK	6	0	18.99	0	0-1
1732.5	20175	1.4	16-QAM	1	0	18.89	0	0-1
1732.5	20175	1.4	16-QAM	1	2	19.00	0	0-1
1732.5	20175	1.4	16-QAM	1	5	19.01	0	0-1
1732.5	20175	1.4	16-QAM	3	0	18.96	0	0-1
1732.5	20175	1.4	16-QAM	3	2	18.97	0	0-1
1732.5	20175	1.4	16-QAM	3	3	19.03	0	0-1
1732.5	20175	1.4	16-QAM	6	0	18.81	0	0-2
1754.3	20393	1.4	QPSK	1	0	18.97	0	0
1754.3	20393	1.4	QPSK	1	2	18.96	0	0
1754.3	20393	1.4	QPSK	1	5	18.72	0	0
1754.3	20393	1.4	QPSK	3	0	18.88	0	0
1754.3	20393	1.4	QPSK	3	2	18.82	0	0
1754.3	20393	1.4	QPSK	3	3	18.85	0	0
1754.3	20393	1.4	QPSK	6	0	18.76	0	0-1
1754.3	20393	1.4	16-QAM	1	0	18.90	0	0-1
1754.3	20393	1.4	16-QAM	1	2	18.84	0	0-1
1754.3	20393	1.4	16-QAM	1	5	18.88	0	0-1
1754.3	20393	1.4	16-QAM	3	0	18.95	0	0-1
1754.3	20393	1.4	16-QAM	3	2	18.73	0	0-1
1754.3	20393	1.4	16-QAM	3	3	18.85	0	0-1
1754.3	20393	1.4	16-QAM	6	0	18.71	0	0-2



**Table 10-27**  
**Reduced LTE Band 4 Conducted Powers Target 15 dBm – 10 MHz Bandwidth**

Frequency [MHz]	Channel	Bandwidth [MHz]	Modulation	RB Size	RB Offset	Conducted Power [dBm]	Target MPR [dB]	MPR Allowed per 3GPP [dB]
1715	20000	10	QPSK	1	0	14.98	0	0
1715	20000	10	QPSK	1	25	14.85	0	0
1715	20000	10	QPSK	1	49	14.84	0	0
1715	20000	10	QPSK	25	0	14.88	0	0-1
1715	20000	10	QPSK	25	12	14.95	0	0-1
1715	20000	10	QPSK	25	25	14.91	0	0-1
1715	20000	10	QPSK	50	0	14.95	0	0-1
1715	20000	10	16QAM	1	0	15.10	0	0-1
1715	20000	10	16QAM	1	25	15.09	0	0-1
1715	20000	10	16QAM	1	49	15.11	0	0-1
1715	20000	10	16QAM	25	0	14.85	0	0-2
1715	20000	10	16QAM	25	12	14.91	0	0-2
1715	20000	10	16QAM	25	25	14.90	0	0-2
1715	20000	10	16QAM	50	0	14.92	0	0-2
1732.5	20175	10	QPSK	1	0	<b>15.07</b>	0	0
1732.5	20175	10	QPSK	1	25	14.84	0	0
1732.5	20175	10	QPSK	1	49	14.58	0	0
1732.5	20175	10	QPSK	25	0	14.96	0	0-1
1732.5	20175	10	QPSK	25	12	14.88	0	0-1
1732.5	20175	10	QPSK	25	25	14.95	0	0-1
1732.5	20175	10	QPSK	50	0	14.91	0	0-1
1732.5	20175	10	16QAM	1	0	15.31	0	0-1
1732.5	20175	10	16QAM	1	25	15.21	0	0-1
1732.5	20175	10	16QAM	1	49	14.90	0	0-1
1732.5	20175	10	16QAM	25	0	14.97	0	0-2
1732.5	20175	10	16QAM	25	12	14.99	0	0-2
1732.5	20175	10	16QAM	25	25	14.94	0	0-2
1732.5	20175	10	16QAM	50	0	15.01	0	0-2
1750	20350	10	QPSK	1	0	14.85	0	0
1750	20350	10	QPSK	1	25	15.02	0	0
1750	20350	10	QPSK	1	49	14.54	0	0
1750	20350	10	QPSK	25	0	<b>15.14</b>	0	0-1
1750	20350	10	QPSK	25	12	15.03	0	0-1
1750	20350	10	QPSK	25	25	15.07	0	0-1
1750	20350	10	QPSK	50	0	15.01	0	0-1
1750	20350	10	16QAM	1	0	14.72	0	0-1
1750	20350	10	16QAM	1	25	14.66	0	0-1
1750	20350	10	16QAM	1	49	14.70	0	0-1
1750	20350	10	16QAM	25	0	14.55	0	0-2
1750	20350	10	16QAM	25	12	14.50	0	0-2
1750	20350	10	16QAM	25	25	14.53	0	0-2
1750	20350	10	16QAM	50	0	14.51	0	0-2

**LTE Notes:**

1. Please refer to Section 8.4.4 for LTE testing requirements per FCC KDB 941225 D05.
2. The bolded powers were tested for SAR.

**Table 10-28**

FCC ID: V65C6721A1		<b>SAR EVALUATION REPORT</b>		Reviewed by: Quality Manager
Document S/N: OY1212071742-R4.V65	Test Dates: 12/10/12 - 02/22/13	DUT Type: Portable Handset		Page 43 of 82

### Reduced LTE Band 4 Conducted Powers Target 15 dBm – 5 MHz Bandwidth

Frequency [MHz]	Channel	Bandwidth [MHz]	Modulation	RB Size	RB Offset	Conducted Power [dBm]	Target MPR [dB]	MPR Allowed per 3GPP [dB]
1712.5	19975	5	QPSK	1	0	14.96	0	0
1712.5	19975	5	QPSK	1	12	14.85	0	0
1712.5	19975	5	QPSK	1	24	14.89	0	0
1712.5	19975	5	QPSK	12	0	14.99	0	0-1
1712.5	19975	5	QPSK	12	6	14.96	0	0-1
1712.5	19975	5	QPSK	12	13	14.90	0	0-1
1712.5	19975	5	QPSK	25	0	14.86	0	0-1
1712.5	19975	5	16-QAM	1	0	15.01	0	0-1
1712.5	19975	5	16-QAM	1	12	15.02	0	0-1
1712.5	19975	5	16-QAM	1	24	14.92	0	0-1
1712.5	19975	5	16-QAM	12	0	14.96	0	0-2
1712.5	19975	5	16-QAM	12	6	14.82	0	0-2
1712.5	19975	5	16-QAM	12	13	14.91	0	0-2
1712.5	19975	5	16-QAM	25	0	14.89	0	0-2
1732.5	20175	5	QPSK	1	0	15.17	0	0
1732.5	20175	5	QPSK	1	12	15.21	0	0
1732.5	20175	5	QPSK	1	24	15.09	0	0
1732.5	20175	5	QPSK	12	0	15.02	0	0-1
1732.5	20175	5	QPSK	12	6	15.34	0	0-1
1732.5	20175	5	QPSK	12	13	15.32	0	0-1
1732.5	20175	5	QPSK	25	0	14.82	0	0-1
1732.5	20175	5	16-QAM	1	0	15.11	0	0-1
1732.5	20175	5	16-QAM	1	12	15.02	0	0-1
1732.5	20175	5	16-QAM	1	24	15.27	0	0-1
1732.5	20175	5	16-QAM	12	0	14.86	0	0-2
1732.5	20175	5	16-QAM	12	6	14.84	0	0-2
1732.5	20175	5	16-QAM	12	13	14.85	0	0-2
1732.5	20175	5	16-QAM	25	0	14.91	0	0-2
1752.5	20375	5	QPSK	1	0	15.21	0	0
1752.5	20375	5	QPSK	1	12	15.23	0	0
1752.5	20375	5	QPSK	1	24	14.99	0	0
1752.5	20375	5	QPSK	12	0	15.22	0	0-1
1752.5	20375	5	QPSK	12	6	15.19	0	0-1
1752.5	20375	5	QPSK	12	13	15.15	0	0-1
1752.5	20375	5	QPSK	25	0	15.22	0	0-1
1752.5	20375	5	16-QAM	1	0	15.35	0	0-1
1752.5	20375	5	16-QAM	1	12	15.27	0	0-1
1752.5	20375	5	16-QAM	1	24	15.22	0	0-1
1752.5	20375	5	16-QAM	12	0	15.05	0	0-2
1752.5	20375	5	16-QAM	12	6	15.14	0	0-2
1752.5	20375	5	16-QAM	12	13	15.13	0	0-2
1752.5	20375	5	16-QAM	25	0	15.04	0	0-2

Table 10-29

### Reduced LTE Band 4 Conducted Powers Target 15 dBm – 3 MHz Bandwidth

Frequency [MHz]	Channel	Bandwidth [MHz]	Modulation	RB Size	RB Offset	Conducted Power [dBm]	Target MPR [dB]	MPR Allowed per 3GPP [dB]
1711.5	19665	3	QPSK	1	0	14.98	0	0
1711.5	19665	3	QPSK	1	7	14.87	0	0
1711.5	19665	3	QPSK	1	14	14.90	0	0
1711.5	19665	3	QPSK	8	0	14.99	0	0-1
1711.5	19665	3	QPSK	8	4	14.92	0	0-1
1711.5	19665	3	QPSK	8	7	14.98	0	0-1
1711.5	19665	3	QPSK	15	0	14.83	0	0-1
1711.5	19665	3	16-QAM	1	0	14.83	0	0-1
1711.5	19665	3	16-QAM	1	7	14.94	0	0-1
1711.5	19665	3	16-QAM	1	14	14.96	0	0-1
1711.5	19665	3	16-QAM	8	0	14.98	0	0-2
1711.5	19665	3	16-QAM	8	4	14.84	0	0-2
1711.5	19665	3	16-QAM	8	7	14.83	0	0-2
1711.5	19665	3	16-QAM	15	0	14.82	0	0-2
1732.5	20175	3	QPSK	1	0	14.98	0	0
1732.5	20175	3	QPSK	1	7	14.90	0	0
1732.5	20175	3	QPSK	1	14	14.67	0	0
1732.5	20175	3	QPSK	8	0	14.85	0	0-1
1732.5	20175	3	QPSK	8	4	14.83	0	0-1
1732.5	20175	3	QPSK	8	7	14.79	0	0-1
1732.5	20175	3	QPSK	15	0	14.86	0	0-1
1732.5	20175	3	16-QAM	1	0	15.18	0	0-1
1732.5	20175	3	16-QAM	1	7	15.05	0	0-1
1732.5	20175	3	16-QAM	1	14	14.84	0	0-1
1732.5	20175	3	16-QAM	8	0	14.88	0	0-2
1732.5	20175	3	16-QAM	8	4	14.87	0	0-2
1732.5	20175	3	16-QAM	8	7	14.84	0	0-2
1732.5	20175	3	16-QAM	15	0	14.90	0	0-2
1753.5	20385	3	QPSK	1	0	15.00	0	0
1753.5	20385	3	QPSK	1	7	14.92	0	0
1753.5	20385	3	QPSK	1	14	14.72	0	0
1753.5	20385	3	QPSK	8	0	15.06	0	0-1
1753.5	20385	3	QPSK	8	4	15.04	0	0-1
1753.5	20385	3	QPSK	8	7	15.00	0	0-1
1753.5	20385	3	QPSK	15	0	15.08	0	0-1
1753.5	20385	3	16-QAM	1	0	15.02	0	0-1
1753.5	20385	3	16-QAM	1	7	15.08	0	0-1
1753.5	20385	3	16-QAM	1	14	15.04	0	0-1
1753.5	20385	3	16-QAM	8	0	15.07	0	0-2
1753.5	20385	3	16-QAM	8	4	15.06	0	0-2
1753.5	20385	3	16-QAM	8	7	15.03	0	0-2
1753.5	20385	3	16-QAM	15	0	15.10	0	0-2

Table 10-30

## Reduced LTE Band 4 Conducted Powers Target 15 dBm – 1.4 MHz Bandwidth

Frequency [MHz]	Channel	Bandwidth [MHz]	Modulation	RB Size	RB Offset	Conducted Power [dBm]	Target MPR [dB]	MPR Allowed per 3GPP [dB]
1710.7	19967	1.4	QPSK	1	0	14.94	0	0
1710.7	19967	1.4	QPSK	1	2	14.82	0	0
1710.7	19967	1.4	QPSK	1	5	14.85	0	0
1710.7	19967	1.4	QPSK	3	0	14.95	0	0
1710.7	19967	1.4	QPSK	3	2	14.86	0	0
1710.7	19967	1.4	QPSK	3	3	14.94	0	0
1710.7	19967	1.4	QPSK	6	0	14.80	0	0-1
1710.7	19967	1.4	16-QAM	1	0	14.81	0	0-1
1710.7	19967	1.4	16-QAM	1	2	14.91	0	0-1
1710.7	19967	1.4	16-QAM	1	5	14.92	0	0-1
1710.7	19967	1.4	16-QAM	3	0	14.93	0	0-1
1710.7	19967	1.4	16-QAM	3	2	14.81	0	0-1
1710.7	19967	1.4	16-QAM	3	3	14.80	0	0-1
1710.7	19967	1.4	16-QAM	6	0	14.98	0	0-2
1732.5	20175	1.4	QPSK	1	0	15.03	0	0
1732.5	20175	1.4	QPSK	1	2	15.07	0	0
1732.5	20175	1.4	QPSK	1	5	14.99	0	0
1732.5	20175	1.4	QPSK	3	0	14.92	0	0
1732.5	20175	1.4	QPSK	3	2	14.85	0	0
1732.5	20175	1.4	QPSK	3	3	14.78	0	0
1732.5	20175	1.4	QPSK	6	0	14.71	0	0-1
1732.5	20175	1.4	16-QAM	1	0	14.64	0	0-1
1732.5	20175	1.4	16-QAM	1	2	14.75	0	0-1
1732.5	20175	1.4	16-QAM	1	5	14.68	0	0-1
1732.5	20175	1.4	16-QAM	3	0	14.73	0	0-1
1732.5	20175	1.4	16-QAM	3	2	14.66	0	0-1
1732.5	20175	1.4	16-QAM	3	3	14.79	0	0-1
1732.5	20175	1.4	16-QAM	6	0	14.78	0	0-2
1754.3	20393	1.4	QPSK	1	0	15.09	0	0
1754.3	20393	1.4	QPSK	1	2	15.01	0	0
1754.3	20393	1.4	QPSK	1	5	14.93	0	0
1754.3	20393	1.4	QPSK	3	0	14.86	0	0
1754.3	20393	1.4	QPSK	3	2	14.97	0	0
1754.3	20393	1.4	QPSK	3	3	14.90	0	0
1754.3	20393	1.4	QPSK	6	0	14.83	0	0-1
1754.3	20393	1.4	16-QAM	1	0	14.86	0	0-1
1754.3	20393	1.4	16-QAM	1	2	14.79	0	0-1
1754.3	20393	1.4	16-QAM	1	5	14.72	0	0-1
1754.3	20393	1.4	16-QAM	3	0	14.85	0	0-1
1754.3	20393	1.4	16-QAM	3	2	14.78	0	0-1
1754.3	20393	1.4	16-QAM	3	3	15.01	0	0-1
1754.3	20393	1.4	16-QAM	6	0	14.94	0	0-2

## 10.3.5 Reduced LTE Band 2 Conducted Powers



Table 10-31

### Reduced LTE Band 2 Conducted Powers Target 19 dBm – 10 MHz Bandwidth

Frequency [MHz]	Channel	Bandwidth [MHz]	Modulation	RB Size	RB Offset	Conducted Power [dBm]	Target MPR [dB]	MPR Allowed per 3GPP [dB]
1855	18650	10	QPSK	1	0	18.98	0	0
1855	18650	10	QPSK	1	25	19.07	0	0
1855	18650	10	QPSK	1	49	19.05	0	0
1855	18650	10	QPSK	25	0	19.07	0	0-1
1855	18650	10	QPSK	25	12	18.99	0	0-1
1855	18650	10	QPSK	25	25	18.91	0	0-1
1855	18650	10	QPSK	50	0	18.92	0	0-1
1855	18650	10	16QAM	1	0	19.08	0	0-1
1855	18650	10	16QAM	1	25	19.13	0	0-1
1855	18650	10	16QAM	1	49	19.17	0	0-1
1855	18650	10	16QAM	25	0	19.09	0	0-2
1855	18650	10	16QAM	25	12	19.02	0	0-2
1855	18650	10	16QAM	25	25	18.91	0	0-2
1855	18650	10	16QAM	50	0	18.90	0	0-2
1880.0	18900	10	QPSK	1	0	19.09	0	0
1880.0	18900	10	QPSK	1	25	19.16	0	0
1880.0	18900	10	QPSK	1	49	<b>19.17</b>	0	0
1880.0	18900	10	QPSK	25	0	18.99	0	0-1
1880.0	18900	10	QPSK	25	12	19.08	0	0-1
1880.0	18900	10	QPSK	25	25	<b>19.18</b>	0	0-1
1880.0	18900	10	QPSK	50	0	18.96	0	0-1
1880.0	18900	10	16QAM	1	0	19.15	0	0-1
1880.0	18900	10	16QAM	1	25	19.22	0	0-1
1880.0	18900	10	16QAM	1	49	19.24	0	0-1
1880.0	18900	10	16QAM	25	0	18.90	0	0-2
1880.0	18900	10	16QAM	25	12	19.01	0	0-2
1880.0	18900	10	16QAM	25	25	19.08	0	0-2
1880.0	18900	10	16QAM	50	0	18.90	0	0-2
1905	19150	10	QPSK	1	0	18.86	0	0
1905	19150	10	QPSK	1	25	18.95	0	0
1905	19150	10	QPSK	1	49	18.63	0	0
1905	19150	10	QPSK	25	0	18.84	0	0-1
1905	19150	10	QPSK	25	12	18.80	0	0-1
1905	19150	10	QPSK	25	25	18.73	0	0-1
1905	19150	10	QPSK	50	0	18.80	0	0-1
1905	19150	10	16QAM	1	0	18.98	0	0-1
1905	19150	10	16QAM	1	25	19.01	0	0-1
1905	19150	10	16QAM	1	49	18.68	0	0-1
1905	19150	10	16QAM	25	0	18.84	0	0-2
1905	19150	10	16QAM	25	12	18.75	0	0-2
1905	19150	10	16QAM	25	25	18.71	0	0-2
1905	19150	10	16QAM	50	0	18.78	0	0-2

LTE Notes:

1. Please refer to Section 8.4.4 for LTE testing requirements per FCC KDB 941225 D05.
2. The bolded powers were tested for SAR.

FCC ID: V65C6721A1	 <b>PCTEST</b> ENGINEERING LABORATORY, INC.	<b>SAR EVALUATION REPORT</b>	 <b>KYOCERA</b>	Reviewed by: Quality Manager
Document S/N: OY1212071742-R4.V65	Test Dates: 12/10/12 - 02/22/13	DUT Type: Portable Handset		Page 45 of 82

**Table 10-32**  
**Reduced LTE Band 2 Conducted Powers Target 19 dBm – 5 MHz Bandwidth**

Frequency [MHz]	Channel	Bandwidth [MHz]	Modulation	RB Size	RB Offset	Conducted Power [dBm]	Target MPR [dB]	MPR Allowed per 3GPP [dB]
1852.5	18625	5	QPSK	1	0	19.05	0	0
1852.5	18625	5	QPSK	1	12	19.06	0	0
1852.5	18625	5	QPSK	1	24	19.13	0	0
1852.5	18625	5	QPSK	12	0	19.06	0	-0.1
1852.5	18625	5	QPSK	12	6	19.07	0	-0.1
1852.5	18625	5	QPSK	12	13	18.92	0	-0.1
1852.5	18625	5	QPSK	25	0	19.00	0	-0.1
1852.5	18625	5	16-QAM	1	0	19.09	0	-0.1
1852.5	18625	5	16-QAM	1	12	19.21	0	-0.1
1852.5	18625	5	16-QAM	1	24	19.18	0	-0.1
1852.5	18625	5	16-QAM	12	0	19.17	0	-0.2
1852.5	18625	5	16-QAM	12	6	19.03	0	-0.2
1852.5	18625	5	16-QAM	12	13	18.99	0	-0.2
1852.5	18625	5	16-QAM	25	0	18.91	0	-0.2
1880.0	18900	5	QPSK	1	0	19.25	0	0
1880.0	18900	5	QPSK	1	12	19.17	0	0
1880.0	18900	5	QPSK	1	24	19.25	0	0
1880.0	18900	5	QPSK	12	0	19.00	0	-0.1
1880.0	18900	5	QPSK	12	6	19.16	0	-0.1
1880.0	18900	5	QPSK	12	13	19.19	0	-0.1
1880.0	18900	5	QPSK	25	0	19.05	0	-0.1
1880.0	18900	5	16-QAM	1	0	19.11	0	-0.1
1880.0	18900	5	16-QAM	1	12	19.31	0	-0.1
1880.0	18900	5	16-QAM	1	24	19.25	0	-0.1
1880.0	18900	5	16-QAM	12	0	18.98	0	-0.2
1880.0	18900	5	16-QAM	12	6	19.02	0	-0.2
1880.0	18900	5	16-QAM	12	13	19.15	0	-0.2
1880.0	18900	5	16-QAM	25	0	18.92	0	-0.2
1907.5	19175	5	QPSK	1	0	18.94	0	0
1907.5	19175	5	QPSK	1	12	18.99	0	0
1907.5	19175	5	QPSK	1	24	18.72	0	0
1907.5	19175	5	QPSK	12	0	18.85	0	-0.1
1907.5	19175	5	QPSK	12	6	18.88	0	-0.1
1907.5	19175	5	QPSK	12	13	18.74	0	-0.1
1907.5	19175	5	QPSK	25	0	18.96	0	-0.1
1907.5	19175	5	16-QAM	1	0	18.99	0	-0.1
1907.5	19175	5	16-QAM	1	12	19.09	0	-0.1
1907.5	19175	5	16-QAM	1	24	18.69	0	-0.1
1907.5	19175	5	16-QAM	12	0	18.92	0	-0.2
1907.5	19175	5	16-QAM	12	6	18.76	0	-0.2
1907.5	19175	5	16-QAM	12	13	18.79	0	-0.2
1907.5	19175	5	16-QAM	25	0	19.02	0	-0.2

**Table 10-33**  
**Reduced LTE Band 2 Conducted Powers Target 19 dBm – 3 MHz Bandwidth**

Frequency [MHz]	Channel	Bandwidth [MHz]	Modulation	RB Size	RB Offset	Conducted Power [dBm]	Target MPR [dB]	MPR Allowed per 3GPP [dB]
1851.5	18615	3	QPSK	1	0	19.11	0	0
1851.5	18615	3	QPSK	1	7	19.13	0	0
1851.5	18615	3	QPSK	1	14	19.28	0	0
1851.5	18615	3	QPSK	8	0	19.11	0	-0.1
1851.5	18615	3	QPSK	8	4	19.21	0	-0.1
1851.5	18615	3	QPSK	8	7	19.07	0	-0.1
1851.5	18615	3	QPSK	15	0	19.05	0	-0.1
1851.5	18615	3	16-QAM	1	0	19.14	0	-0.1
1851.5	18615	3	16-QAM	1	7	19.22	0	-0.1
1851.5	18615	3	16-QAM	1	14	19.33	0	-0.1
1851.5	18615	3	16-QAM	8	0	19.32	0	-0.2
1851.5	18615	3	16-QAM	8	4	19.18	0	-0.2
1851.5	18615	3	16-QAM	8	7	19.04	0	-0.2
1851.5	18615	3	16-QAM	15	0	18.99	0	-0.2
1880.0	18900	3	QPSK	1	0	19.31	0	0
1880.0	18900	3	QPSK	1	7	19.22	0	0
1880.0	18900	3	QPSK	1	14	19.30	0	0
1880.0	18900	3	QPSK	8	0	19.05	0	-0.1
1880.0	18900	3	QPSK	8	4	19.25	0	-0.1
1880.0	18900	3	QPSK	8	7	19.23	0	-0.1
1880.0	18900	3	QPSK	15	0	19.13	0	-0.1
1880.0	18900	3	16-QAM	1	0	19.16	0	-0.1
1880.0	18900	3	16-QAM	1	7	19.33	0	-0.1
1880.0	18900	3	16-QAM	1	14	19.34	0	-0.1
1880.0	18900	3	16-QAM	8	0	19.06	0	-0.2
1880.0	18900	3	16-QAM	8	4	19.03	0	-0.2
1880.0	18900	3	16-QAM	8	7	19.21	0	-0.2
1880.0	18900	3	16-QAM	15	0	19.01	0	-0.2
1908.5	19185	3	QPSK	1	0	19.00	0	0
1908.5	19185	3	QPSK	1	7	19.04	0	0
1908.5	19185	3	QPSK	1	14	18.77	0	0
1908.5	19185	3	QPSK	8	0	18.99	0	-0.1
1908.5	19185	3	QPSK	8	4	18.93	0	-0.1
1908.5	19185	3	QPSK	8	7	18.75	0	-0.1
1908.5	19185	3	QPSK	15	0	19.02	0	-0.1
1908.5	19185	3	16-QAM	1	0	19.04	0	-0.1
1908.5	19185	3	16-QAM	1	7	19.10	0	-0.1
1908.5	19185	3	16-QAM	1	14	18.75	0	-0.1
1908.5	19185	3	16-QAM	8	0	18.96	0	-0.2
1908.5	19185	3	16-QAM	8	4	18.81	0	-0.2
1908.5	19185	3	16-QAM	8	7	18.84	0	-0.2
1908.5	19185	3	16-QAM	15	0	18.97	0	-0.2

**Table 10-34**  
**Reduced LTE Band 2 Conducted Powers Target 19 dBm – 1.4 MHz Bandwidth**



Frequency [MHz]	Channel	Bandwidth [MHz]	Modulation	RB Size	RB Offset	Conducted Power [dBm]	Target MPR [dB]	MPR Allowed per 3GPP [dB]
1850.7	18607	1.4	QPSK	1	0	19.07	0	0
1850.7	18607	1.4	QPSK	1	2	19.02	0	0
1850.7	18607	1.4	QPSK	1	5	19.24	0	0
1850.7	18607	1.4	QPSK	3	0	19.07	0	0
1850.7	18607	1.4	QPSK	3	2	19.17	0	0
1850.7	18607	1.4	QPSK	3	3	19.03	0	0
1850.7	18607	1.4	QPSK	6	0	18.94	0	0-1
1850.7	18607	1.4	16-QAM	1	0	19.03	0	0-1
1850.7	18607	1.4	16-QAM	1	2	19.11	0	0-1
1850.7	18607	1.4	16-QAM	1	5	19.29	0	0-1
1850.7	18607	1.4	16-QAM	3	0	19.28	0	0-1
1850.7	18607	1.4	16-QAM	3	2	19.14	0	0-1
1850.7	18607	1.4	16-QAM	3	3	18.93	0	0-1
1850.7	18607	1.4	16-QAM	6	0	18.88	0	0-2
1880.0	18900	1.4	QPSK	1	0	19.20	0	0
1880.0	18900	1.4	QPSK	1	2	19.18	0	0
1880.0	18900	1.4	QPSK	1	5	19.26	0	0
1880.0	18900	1.4	QPSK	3	0	19.01	0	0
1880.0	18900	1.4	QPSK	3	2	19.21	0	0
1880.0	18900	1.4	QPSK	3	3	19.19	0	0
1880.0	18900	1.4	QPSK	6	0	19.02	0	0-1
1880.0	18900	1.4	16-QAM	1	0	19.05	0	0-1
1880.0	18900	1.4	16-QAM	1	2	19.29	0	0-1
1880.0	18900	1.4	16-QAM	1	5	19.30	0	0-1
1880.0	18900	1.4	16-QAM	3	0	18.95	0	0-1
1880.0	18900	1.4	16-QAM	3	2	18.92	0	0-1
1880.0	18900	1.4	16-QAM	3	3	19.10	0	0-1
1880.0	18900	1.4	16-QAM	6	0	18.97	0	0-2
1909.3	19193	1.4	QPSK	1	0	18.96	0	0
1909.3	19193	1.4	QPSK	1	2	19.00	0	0
1909.3	19193	1.4	QPSK	1	5	18.73	0	0
1909.3	19193	1.4	QPSK	3	0	18.88	0	0
1909.3	19193	1.4	QPSK	3	2	18.82	0	0
1909.3	19193	1.4	QPSK	3	3	18.64	0	0
1909.3	19193	1.4	QPSK	6	0	18.91	0	0-1
1909.3	19193	1.4	16-QAM	1	0	18.93	0	0-1
1909.3	19193	1.4	16-QAM	1	2	18.99	0	0-1
1909.3	19193	1.4	16-QAM	1	5	18.71	0	0-1
1909.3	19193	1.4	16-QAM	3	0	18.92	0	0-1
1909.3	19193	1.4	16-QAM	3	2	18.77	0	0-1
1909.3	19193	1.4	16-QAM	3	3	18.73	0	0-1
1909.3	19193	1.4	16-QAM	6	0	18.86	0	0-2

**Table 10-35**  
**Reduced LTE Band 2 Conducted Powers Target 15 dBm – 10 MHz Bandwidth**

Frequency [MHz]	Channel	Bandwidth [MHz]	Modulation	RB Size	RB Offset	Conducted Power [dBm]	Target MPR [dB]	MPR Allowed per 3GPP [dB]
1855	18650	10	QPSK	1	0	15.35	0	0
1855	18650	10	QPSK	1	25	15.37	0	0
1855	18650	10	QPSK	1	49	15.41	0	0
1855	18650	10	QPSK	25	0	<b>15.50</b>	0	0-1
1855	18650	10	QPSK	25	12	15.46	0	0-1
1855	18650	10	QPSK	25	25	15.35	0	0-1
1855	18650	10	QPSK	50	0	15.40	0	0-1
1855	18650	10	16QAM	1	0	14.89	0	0-1
1855	18650	10	16QAM	1	25	14.94	0	0-1
1855	18650	10	16QAM	1	49	14.95	0	0-1
1855	18650	10	16QAM	25	0	14.87	0	0-2
1855	18650	10	16QAM	25	12	14.81	0	0-2
1855	18650	10	16QAM	25	25	14.72	0	0-2
1855	18650	10	16QAM	50	0	14.81	0	0-2
1880.0	18900	10	QPSK	1	0	15.10	0	0
1880.0	18900	10	QPSK	1	25	15.17	0	0
1880.0	18900	10	QPSK	1	49	15.14	0	0
1880.0	18900	10	QPSK	25	0	14.95	0	0-1
1880.0	18900	10	QPSK	25	12	15.10	0	0-1
1880.0	18900	10	QPSK	25	25	15.17	0	0-1
1880.0	18900	10	QPSK	50	0	15.15	0	0-1
1880.0	18900	10	16QAM	1	0	14.83	0	0-1
1880.0	18900	10	16QAM	1	25	15.32	0	0-1
1880.0	18900	10	16QAM	1	49	14.50	0	0-1
1880.0	18900	10	16QAM	25	0	14.99	0	0-2
1880.0	18900	10	16QAM	25	12	15.03	0	0-2
1880.0	18900	10	16QAM	25	25	14.84	0	0-2
1880.0	18900	10	16QAM	50	0	14.81	0	0-2
1905	19150	10	QPSK	1	0	14.83	0	0
1905	19150	10	QPSK	1	25	14.84	0	0
1905	19150	10	QPSK	1	49	14.54	0	0
1905	19150	10	QPSK	25	0	15.00	0	0-1
1905	19150	10	QPSK	25	12	14.85	0	0-1
1905	19150	10	QPSK	25	25	14.87	0	0-1
1905	19150	10	QPSK	50	0	14.95	0	0-1
1905	19150	10	16QAM	1	0	15.01	0	0-1
1905	19150	10	16QAM	1	25	15.04	0	0-1
1905	19150	10	16QAM	1	49	14.50	0	0-1
1905	19150	10	16QAM	25	0	14.91	0	0-2
1905	19150	10	16QAM	25	12	14.76	0	0-2
1905	19150	10	16QAM	25	25	14.50	0	0-2
1905	19150	10	16QAM	50	0	14.73	0	0-2

LTE Notes:

1. Please refer to Section 8.4.4 for LTE testing requirements per FCC KDB 941225 D05.
2. The bolded powers were tested for SAR.

FCC ID: V65C6721A1		SAR EVALUATION REPORT		Reviewed by: Quality Manager
Document S/N: OY1212071742-R4.V65	Test Dates: 12/10/12 - 02/22/13	DUT Type: Portable Handset		Page 47 of 82



**Table 10-36**  
**Reduced LTE Band 2 Conducted Powers Target 15 dBm – 5 MHz Bandwidth**

Frequency [MHz]	Channel	Bandwidth [MHz]	Modulation	RB Size	RB Offset	Conducted Power [dBm]	Target MPR [dB]	MPR Allowed per 3GPP [dB]
1852.5	18625	5	QPSK	1	0	15.46	0	0
1852.5	18625	5	QPSK	1	12	15.54	0	0
1852.5	18625	5	QPSK	1	24	15.54	0	0
1852.5	18625	5	QPSK	12	0	15.67	0	0-1
1852.5	18625	5	QPSK	12	6	15.59	0	0-1
1852.5	18625	5	QPSK	12	13	15.52	0	0-1
1852.5	18625	5	QPSK	25	0	15.53	0	0-1
1852.5	18625	5	16-QAM	1	0	15.15	0	0-1
1852.5	18625	5	16-QAM	1	12	15.07	0	0-1
1852.5	18625	5	16-QAM	1	24	15.21	0	0-1
1852.5	18625	5	16-QAM	12	0	15.00	0	0-2
1852.5	18625	5	16-QAM	12	6	15.07	0	0-2
1852.5	18625	5	16-QAM	12	13	14.85	0	0-2
1852.5	18625	5	16-QAM	25	0	15.08	0	0-2
1880.0	18900	5	QPSK	1	0	15.23	0	0
1880.0	18900	5	QPSK	1	12	15.43	0	0
1880.0	18900	5	QPSK	1	24	15.27	0	0
1880.0	18900	5	QPSK	12	0	15.21	0	0-1
1880.0	18900	5	QPSK	12	6	15.23	0	0-1
1880.0	18900	5	QPSK	12	13	15.43	0	0-1
1880.0	18900	5	QPSK	25	0	15.28	0	0-1
1880.0	18900	5	16-QAM	1	0	15.09	0	0-1
1880.0	18900	5	16-QAM	1	12	15.45	0	0-1
1880.0	18900	5	16-QAM	1	24	14.75	0	0-1
1880.0	18900	5	16-QAM	12	0	15.12	0	0-2
1880.0	18900	5	16-QAM	12	6	15.29	0	0-2
1880.0	18900	5	16-QAM	12	13	14.97	0	0-2
1880.0	18900	5	16-QAM	25	0	15.07	0	0-2
1907.5	19175	5	QPSK	1	0	14.96	0	0
1907.5	19175	5	QPSK	1	12	15.10	0	0
1907.5	19175	5	QPSK	1	24	14.67	0	0
1907.5	19175	5	QPSK	12	0	15.26	0	0-1
1907.5	19175	5	QPSK	12	6	14.98	0	0-1
1907.5	19175	5	QPSK	12	13	15.13	0	0-1
1907.5	19175	5	QPSK	25	0	15.08	0	0-1
1907.5	19175	5	16-QAM	1	0	15.27	0	0-1
1907.5	19175	5	16-QAM	1	12	15.17	0	0-1
1907.5	19175	5	16-QAM	1	24	14.75	0	0-1
1907.5	19175	5	16-QAM	12	0	15.04	0	0-2
1907.5	19175	5	16-QAM	12	6	15.02	0	0-2
1907.5	19175	5	16-QAM	12	13	14.63	0	0-2
1907.5	19175	5	16-QAM	25	0	14.98	0	0-2

**Table 10-37**  
**Reduced LTE Band 2 Conducted Powers Target 15 dBm – 3 MHz Bandwidth**

Frequency [MHz]	Channel	Bandwidth [MHz]	Modulation	RB Size	RB Offset	Conducted Power [dBm]	Target MPR [dB]	MPR Allowed per 3GPP [dB]
1851.5	18615	3	QPSK	1	0	15.50	0	0
1851.5	18615	3	QPSK	1	7	15.46	0	0
1851.5	18615	3	QPSK	1	14	15.47	0	0
1851.5	18615	3	QPSK	8	0	15.59	0	0-1
1851.5	18615	3	QPSK	8	4	15.62	0	0-1
1851.5	18615	3	QPSK	8	7	15.64	0	0-1
1851.5	18615	3	QPSK	15	0	15.46	0	0-1
1851.5	18615	3	16-QAM	1	0	15.17	0	0-1
1851.5	18615	3	16-QAM	1	7	15.09	0	0-1
1851.5	18615	3	16-QAM	1	14	15.23	0	0-1
1851.5	18615	3	16-QAM	8	0	15.02	0	0-2
1851.5	18615	3	16-QAM	8	4	15.09	0	0-2
1851.5	18615	3	16-QAM	8	7	14.87	0	0-2
1851.5	18615	3	16-QAM	15	0	15.09	0	0-2
1880.0	18900	3	QPSK	1	0	15.25	0	0
1880.0	18900	3	QPSK	1	7	15.45	0	0
1880.0	18900	3	QPSK	1	14	15.29	0	0
1880.0	18900	3	QPSK	8	0	15.23	0	0-1
1880.0	18900	3	QPSK	8	4	15.25	0	0-1
1880.0	18900	3	QPSK	8	7	15.45	0	0-1
1880.0	18900	3	QPSK	15	0	15.30	0	0-1
1880.0	18900	3	16-QAM	1	0	15.11	0	0-1
1880.0	18900	3	16-QAM	1	7	15.47	0	0-1
1880.0	18900	3	16-QAM	1	14	14.77	0	0-1
1880.0	18900	3	16-QAM	8	0	15.14	0	0-2
1880.0	18900	3	16-QAM	8	4	15.31	0	0-2
1880.0	18900	3	16-QAM	8	7	14.99	0	0-2
1880.0	18900	3	16-QAM	15	0	15.09	0	0-2
1908.5	19185	3	QPSK	1	0	14.98	0	0
1908.5	19185	3	QPSK	1	7	15.12	0	0
1908.5	19185	3	QPSK	1	14	14.68	0	0
1908.5	19185	3	QPSK	8	0	15.28	0	0-1
1908.5	19185	3	QPSK	8	4	15.00	0	0-1
1908.5	19185	3	QPSK	8	7	15.15	0	0-1
1908.5	19185	3	QPSK	15	0	15.10	0	0-1
1908.5	19185	3	16-QAM	1	0	15.29	0	0-1
1908.5	19185	3	16-QAM	1	7	15.19	0	0-1
1908.5	19185	3	16-QAM	1	14	14.77	0	0-1
1908.5	19185	3	16-QAM	8	0	15.06	0	0-2
1908.5	19185	3	16-QAM	8	4	15.04	0	0-2
1908.5	19185	3	16-QAM	8	7	14.64	0	0-2
1908.5	19185	3	16-QAM	15	0	15.00	0	0-2

**Table 10-38**  
**Reduced LTE Band 2 Conducted Powers Target 15 dBm – 1.4 MHz Bandwidth**



FCC ID: V65C6721A1		SAR EVALUATION REPORT		Reviewed by: Quality Manager
Document S/N: 0Y1212071742-R4.V65	Test Dates: 12/10/12 - 02/22/13	DUT Type: Portable Handset		Page 48 of 82

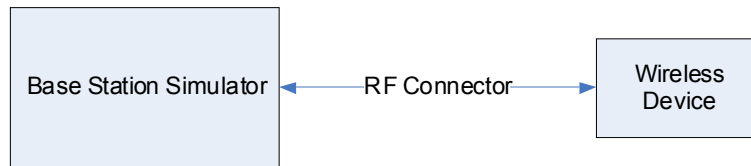

Frequency [MHz]	Channel	Bandwidth [MHz]	Modulation	RB Size	RB Offset	Conducted Power [dBm]	Target MPR [dB]	MPR Allowed per 3GPP [dB]
1850.7	18607	1.4	QPSK	1	0	15.45	0	0
1850.7	18607	1.4	QPSK	1	2	15.42	0	0
1850.7	18607	1.4	QPSK	1	5	15.38	0	0
1850.7	18607	1.4	QPSK	3	0	15.33	0	0
1850.7	18607	1.4	QPSK	3	2	15.56	0	0
1850.7	18607	1.4	QPSK	3	3	15.58	0	0
1850.7	18607	1.4	QPSK	6	0	15.40	0	-1
1850.7	18607	1.4	16-QAM	1	0	15.12	0	-1
1850.7	18607	1.4	16-QAM	1	2	15.14	0	-1
1850.7	18607	1.4	16-QAM	1	5	15.28	0	-1
1850.7	18607	1.4	16-QAM	3	0	14.97	0	-1
1850.7	18607	1.4	16-QAM	3	2	15.24	0	-1
1850.7	18607	1.4	16-QAM	3	3	14.92	0	-1
1850.7	18607	1.4	16-QAM	6	0	15.04	0	-2
1880.0	18900	1.4	QPSK	1	0	15.20	0	0
1880.0	18900	1.4	QPSK	1	2	15.42	0	0
1880.0	18900	1.4	QPSK	1	5	15.26	0	0
1880.0	18900	1.4	QPSK	3	0	15.18	0	0
1880.0	18900	1.4	QPSK	3	2	15.21	0	0
1880.0	18900	1.4	QPSK	3	3	15.34	0	0
1880.0	18900	1.4	QPSK	6	0	15.25	0	-1
1880.0	18900	1.4	16-QAM	1	0	15.08	0	-1
1880.0	18900	1.4	16-QAM	1	2	15.32	0	-1
1880.0	18900	1.4	16-QAM	1	5	14.82	0	-1
1880.0	18900	1.4	16-QAM	3	0	15.19	0	-1
1880.0	18900	1.4	16-QAM	3	2	15.36	0	-1
1880.0	18900	1.4	16-QAM	3	3	14.94	0	-1
1880.0	18900	1.4	16-QAM	6	0	15.04	0	-2
1909.3	19193	1.4	QPSK	1	0	14.95	0	0
1909.3	19193	1.4	QPSK	1	2	15.07	0	0
1909.3	19193	1.4	QPSK	1	5	14.65	0	0
1909.3	19193	1.4	QPSK	3	0	15.23	0	0
1909.3	19193	1.4	QPSK	3	2	14.92	0	0
1909.3	19193	1.4	QPSK	3	3	15.11	0	0
1909.3	19193	1.4	QPSK	6	0	15.06	0	-1
1909.3	19193	1.4	16-QAM	1	0	15.24	0	-1
1909.3	19193	1.4	16-QAM	1	2	15.13	0	-1
1909.3	19193	1.4	16-QAM	1	5	14.72	0	-1
1909.3	19193	1.4	16-QAM	3	0	15.01	0	-1
1909.3	19193	1.4	16-QAM	3	2	14.98	0	-1
1909.3	19193	1.4	16-QAM	3	3	14.62	0	-1
1909.3	19193	1.4	16-QAM	6	0	14.99	0	-2



**Figure 10-2**  
**Power Measurement Setup**

FCC ID: V65C6721A1		<b>SAR EVALUATION REPORT</b>		Reviewed by: Quality Manager
Document S/N: 0Y1212071742-R4.V65	Test Dates: 12/10/12 - 02/22/13	DUT Type: Portable Handset		Page 49 of 82

### 10.3.6 Threshold CDMA Conducted Powers

**Table 10-39  
CDMA RF Power Levels  
at 15 and 20 dBm**

Band	Channel	Frequency	SO55 [dBm]		TDSO SO32 [dBm]	
			RC1	RC3	FCH+SCH	FCH
Cellular	1013	824.7	15.41	15.42	15.39	15.36
	384	836.52	15.42	15.44	15.37	15.39
	777	848.31	15.38	15.40	15.38	15.36
AWS	25	1711.25	20.01	20.04	19.98	20.00
	450	1732.5	20.05	20.07	20.00	20.01
	875	1753.75	20.10	20.12	20.14	20.16
PCS	25	1851.25	20.37	20.36	20.39	20.23
	600	1880	20.34	20.35	20.35	20.37
	1175	1908.75	20.15	20.20	20.33	20.40

**Table 10-40  
CDMA RF Power Levels  
at 10 dBm**

Band	Channel	Frequency	SO55 [dBm]		TDSO SO32 [dBm]	
			RC1	RC3	FCH+SCH	FCH
AWS	25	1711.25	10.13	10.26	10.28	10.35
	450	1732.5	10.33	10.36	10.21	10.28
	875	1753.75	10.09	10.07	10.07	10.04
PCS	25	1851.25	10.27	10.48	10.49	10.48
	600	1880	10.06	10.18	10.15	10.22
	1175	1908.75	9.67	9.80	9.85	9.96

**Notes:**

1. RC1 is only applicable for IS-95 compatibility.
2. There is no power reduction applied to the CDMA Voice modes, however the device with output powers represented in the table above was tuned down (for SAR Test purposes only) to analyze simultaneous SAR scenarios in the SVLTE condition where LTE is operating at maximum output power in conjunction with a lower CDMA voice level (see Table 10-1).

Per KDB Publication 941225 D01v02:

1. Head SAR was tested with SO55 RC3. SO55 RC1 was not required since the average output power was not more than 0.25 dB than the SO55 RC3 powers.
2. Body-Worn SAR was tested with 1x RTT with TDSO / SO32 FCH Only. TDSO / SO32 FCH+SCH SAR tests were not required since the average output power was not more than 0.25 dB higher than the TDSO / SO32 FCH only powers.
3. CDMA 1x-RTT SAR was required to be evaluated for Hotspot exposure conditions to support simultaneous transmission capabilities.



**Figure 10-3  
Power Measurement Setup**

FCC ID: V65C6721A1	PCTEST ENGINEERING LABORATORY, INC.	SAR EVALUATION REPORT	KYOCERA	Reviewed by: Quality Manager
Document S/N: 0Y1212071742-R4.V65	Test Dates: 12/10/12 - 02/22/13	DUT Type: Portable Handset	Page 50 of 82	



# 11 SYSTEM VERIFICATION

## 11.1 Tissue Verification

**Table 11-1  
Measured Tissue Properties**

Calibrated for Tests Performed on:	Tissue Type	Tissue Temp During Calibration (C°)	Measured Frequency (MHz)	Measured Conductivity, $\sigma$ (S/m)	Measured Dielectric Constant, $\epsilon$	TARGET Conductivity, $\sigma$ (S/m)	TARGET Dielectric Constant, $\epsilon$	% dev $\sigma$	% dev $\epsilon$
12/20/2012	750H	22.2	695	0.852	42.49	0.89	42.19	-3.84%	0.70%
			710	0.880	42.37	0.89	42.11	-0.79%	0.61%
			725	0.888	42.40	0.89	42.03	0.00%	0.87%
			740	0.890	42.00	0.89	41.95	0.11%	0.11%
			755	0.904	41.82	0.89	41.88	1.46%	-0.13%
12/17/2012	835H	21.9	820	0.868	41.10	0.90	41.57	-3.34%	-1.13%
			835	0.882	40.73	0.90	41.50	-2.00%	-1.86%
			850	0.878	40.47	0.92	41.50	-4.15%	-2.48%
02/11/2013	835H	23.5	820	0.895	41.05	0.90	41.57	-0.33%	-1.25%
			835	0.912	40.94	0.90	41.50	1.33%	-1.34%
			850	0.928	40.67	0.92	41.50	1.31%	-2.00%
02/07/2013	1750H	19.9	1710	1.326	40.05	1.35	40.14	-1.63%	-0.21%
			1750	1.368	39.83	1.37	40.10	-0.15%	-0.67%
			1790	1.409	39.69	1.39	40.02	1.08%	-0.82%
02/22/2013	1750H	20.3	1710	1.353	39.06	1.35	40.14	0.37%	-2.69%
			1750	1.392	38.78	1.37	40.10	1.61%	-3.29%
			1790	1.429	38.55	1.39	40.02	2.51%	-3.68%
02/08/2013	1900H	22.7	1850	1.404	39.31	1.40	40.00	0.29%	-1.72%
			1880	1.424	39.21	1.40	40.00	1.71%	-1.98%
			1910	1.463	39.10	1.40	40.00	4.50%	-2.25%
02/20/2013	1900H	23.8	1850	1.395	40.63	1.40	40.00	-0.36%	1.57%
			1880	1.425	40.52	1.40	40.00	1.79%	1.30%
			1910	1.454	40.40	1.40	40.00	3.86%	1.00%
12/18/2012	2450H	22.9	2401	1.798	38.61	1.76	39.30	2.28%	-1.75%
			2450	1.847	38.27	1.80	39.20	2.61%	-2.37%
			2499	1.924	38.14	1.85	39.14	3.89%	-2.54%
12/14/2012	750B	20.6	695	0.918	57.42	0.96	55.75	-4.28%	3.00%
			710	0.920	57.07	0.96	55.69	-4.17%	2.48%
			725	0.932	56.85	0.96	55.63	-3.02%	2.19%
			740	0.961	57.00	0.96	55.57	-0.21%	2.57%
			755	0.956	56.83	0.96	55.51	-0.83%	2.37%
12/20/2012	750B	22.1	695	0.918	57.36	0.96	55.75	-4.28%	2.90%
			710	0.924	56.99	0.96	55.69	-3.75%	2.34%
			725	0.937	56.82	0.96	55.63	-2.50%	2.14%
			740	0.961	56.65	0.96	55.57	-0.21%	1.94%
			755	0.964	56.16	0.96	55.51	0.00%	1.17%
12/10/2012	835B	21.7	820	0.987	54.77	0.97	55.26	1.86%	-0.88%
			835	0.993	54.42	0.97	55.20	2.37%	-1.41%
			850	0.999	54.30	0.99	55.15	1.11%	-1.55%
02/19/2013	835B	23.2	820	0.981	53.09	0.97	55.26	1.24%	-3.92%
			835	1.004	53.09	0.97	55.20	3.51%	-3.83%
			850	1.023	52.70	0.99	55.15	3.54%	-4.45%
02/10/2013	1750B	24.0	1710	1.421	52.49	1.46	53.54	-2.67%	-1.96%
			1750	1.461	52.30	1.49	53.43	-1.95%	-2.11%
			1790	1.499	52.19	1.51	53.33	-0.73%	-2.14%
02/07/2013	1900B	21.8	1850	1.500	52.99	1.52	53.30	-1.32%	-0.58%
			1880	1.532	52.88	1.52	53.30	0.79%	-0.79%
			1910	1.572	52.80	1.52	53.30	3.42%	-0.94%
12/11/2012	2450B	23.0	2401	1.915	50.85	1.90	52.77	0.63%	-3.63%
			2450	1.980	50.66	1.95	52.70	1.54%	-3.87%
			2499	2.048	50.49	2.02	52.64	1.44%	-4.08%

The above measured tissue parameters were used in the DASY software. The DASY software was used to perform interpolation to determine the dielectric parameters at the SAR test device frequencies (per IEEE 1528 6.6.1.2). The tissue parameters listed in the SAR test plots may slightly differ from the table above due to significant digit rounding in the software.

FCC ID: V65C6721A1	 PCTEST ENGINEERING LABORATORY, INC.	SAR EVALUATION REPORT	 KYOCERA	Reviewed by: Quality Manager
Document S/N: 0Y1212071742-R4.V65	Test Dates: 12/10/12 - 02/22/13	DUT Type: Portable Handset		Page 51 of 82

## 11.2 Test System Verification

Prior to SAR assessment, the system is verified to  $\pm 10\%$  of the SAR measurement on the reference dipole at the time of calibration by the calibration facility. Full system validation status and result summary can be found in Appendix E.

**Table 11-2**  
**System Verification Results**

System Verification TARGET & MEASURED											
Tissue Frequency (MHz)	Tissue Type	Date:	Amb. Temp (°C)	Liquid Temp (°C)	Input Power (W)	Dipole SN	Probe SN	Measured SAR <sub>1g</sub> (W/kg)	1 W Target SAR <sub>1g</sub> (W/kg)	1 W Normalized SAR <sub>1g</sub> (W/kg)	Deviation (%)
750	HEAD	12/20/2012	23.3	22.2	0.100	1054	3288	0.806	8.520	8.060	-5.40%
835	HEAD	12/17/2012	21.3	20.6	0.100	4d132	3288	0.966	9.450	9.660	2.22%
835	HEAD	02/11/2013	24.4	23.4	0.100	4d119	3022	0.993	9.420	9.930	5.41%
1750	HEAD	02/07/2013	23.4	21.4	0.100	1051	3288	3.440	36.600	34.400	-6.01%
1750	HEAD	02/22/2013	24.1	21.9	0.100	1051	3213	3.730	36.600	37.300	1.91%
1900	HEAD	02/08/2013	24.3	21.9	0.100	5d149	3263	3.940	39.300	39.400	0.25%
1900	HEAD	02/08/2013	22.8	21.3	0.100	5d149	3213	4.150	39.300	41.500	5.60%
1900	HEAD	02/20/2013	23.9	23.5	0.100	5d149	3288	3.940	39.300	39.400	0.25%
2450	HEAD	12/18/2012	23.3	21.4	0.040	719	3258	2.270	52.700	56.750	7.69%
750	BODY	12/14/2012	22.4	22.2	0.057	1054	3263	0.469	8.840	8.228	-6.92%
750	BODY	12/20/2012	24.0	22.2	0.100	1054	3263	0.859	8.840	8.590	-2.83%
835	BODY	12/10/2012	21.9	20.2	0.090	4d132	3263	0.907	9.410	10.078	7.10%
835	BODY	02/19/2013	22.8	22.2	0.100	4d026	3287	1.020	9.580	10.200	6.47%
1750	BODY	02/10/2013	23.3	22.3	0.100	1051	3288	4.040	37.600	40.400	7.45%
1900	BODY	02/07/2013	23.4	22.1	0.100	5d149	3263	4.020	39.300	40.200	2.29%
2450	BODY	12/11/2012	24.4	23.3	0.040	719	3258	2.220	51.600	55.500	7.56%

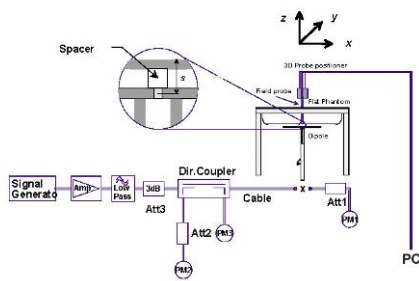

**Figure 11-1**  
**System Verification Setup Diagram**



**Figure 11-2**  
**System Verification Setup Photo**

FCC ID: V65C6721A1	PCTEST ENGINEERING LABORATORY, INC.	SAR EVALUATION REPORT	KYOCERA	Reviewed by: Quality Manager
Document S/N: 0Y1212071742-R4.V65	Test Dates: 12/10/12 - 02/22/13	DUT Type: Portable Handset	Page 52 of 82	

# 12 SAR DATA SUMMARY



## 12.1 Standalone Head SAR Data

**Table 12-1  
Cell. CDMA Head SAR Data**

MEASUREMENT RESULTS														
FREQUENCY		Mode/Band	Service	Maximum Allowed Power [dBm]	Conducted Power [dBm]	Power Drift [dB]	Side	Test Position	Device Serial Number	Duty Cycle	SAR (1g)	Scaling Factor	Scaled SAR (1g)	Plot #
MHz	Ch.										(W/kg)		(W/kg)	
836.52	384	Cell. CDMA	RC3 / SO55	25.2	24.60	0.01	Right	Cheek	SAR CDMA - BC0	1:1	0.694	1.148	0.797	A1
836.52	384	Cell. CDMA	RC3 / SO55	25.2	24.60	0.15	Right	Tilt	SAR CDMA - BC0	1:1	0.394	1.148	0.452	
836.52	384	Cell. CDMA	RC3 / SO55	25.2	24.60	0.00	Left	Cheek	SAR CDMA - BC0	1:1	0.557	1.148	0.639	
836.52	384	Cell. CDMA	RC3 / SO55	25.2	24.60	0.06	Left	Tilt	SAR CDMA - BC0	1:1	0.350	1.148	0.402	
836.52	384	Cell. CDMA	RC3 / SO55	15.7	15.44	0.03	Right	Cheek	SAR CDMA - BC0	1:1	0.083	1.062	0.088	
836.52	384	Cell. CDMA	RC3 / SO55	15.7	15.44	-0.02	Right	Tilt	SAR CDMA - BC0	1:1	0.049	1.062	0.052	
836.52	384	Cell. CDMA	RC3 / SO55	15.7	15.44	0.08	Left	Cheek	SAR CDMA - BC0	1:1	0.066	1.062	0.070	
836.52	384	Cell. CDMA	RC3 / SO55	15.7	15.44	0.01	Left	Tilt	SAR CDMA - BC0	1:1	0.047	1.062	0.049	
836.52	384	Cell. CDMA	EVDO Rev. A	25.2	24.67	-0.02	Right	Cheek	SAR CDMA - BC0	1:1	0.661	1.130	0.747	
836.52	384	Cell. CDMA	EVDO Rev. A	25.2	24.67	-0.01	Right	Tilt	SAR CDMA - BC0	1:1	0.383	1.130	0.433	
836.52	384	Cell. CDMA	EVDO Rev. A	25.2	24.67	-0.02	Left	Cheek	SAR CDMA - BC0	1:1	0.560	1.130	0.633	
836.52	384	Cell. CDMA	EVDO Rev. A	25.2	24.67	0.02	Left	Tilt	SAR CDMA - BC0	1:1	0.376	1.130	0.425	
ANSI / IEEE C95.1 1992 - SAFETY LIMIT Spatial Peak Uncontrolled Exposure/General Population							Head 1.6 W/kg (mW/g) averaged over 1 gram							

**Table 12-2  
AWS CDMA Head SAR Data**

MEASUREMENT RESULTS														
FREQUENCY		Mode/Band	Service	Maximum Allowed Power [dBm]	Conducted Power [dBm]	Power Drift [dB]	Side	Test Position	Device Serial Number	Duty Cycle	SAR (1g)	Scaling Factor	Scaled SAR (1g)	Plot #
MHz	Ch.										(W/kg)		(W/kg)	
1732.50	450	AWS CDMA	RC3 / SO55	24.2	23.70	0.00	Right	Cheek	SAR CDMA - BC15	1:1	0.685	1.122	0.769	A2
1732.50	450	AWS CDMA	RC3 / SO55	24.2	23.70	0.11	Right	Tilt	SAR CDMA - BC15	1:1	0.146	1.122	0.164	
1732.50	450	AWS CDMA	RC3 / SO55	24.2	23.70	0.02	Left	Cheek	SAR CDMA - BC15	1:1	0.433	1.122	0.486	
1732.50	450	AWS CDMA	RC3 / SO55	24.2	23.70	0.06	Left	Tilt	SAR CDMA - BC15	1:1	0.136	1.122	0.153	
1732.50	450	AWS CDMA	RC3 / SO55	20.7	20.07	-0.02	Right	Cheek	SAR CDMA - BC15	1:1	0.299	1.156	0.346	
1732.50	450	AWS CDMA	RC3 / SO55	20.7	20.07	0.09	Right	Tilt	SAR CDMA - BC15	1:1	0.068	1.156	0.078	
1732.50	450	AWS CDMA	RC3 / SO55	20.7	20.07	-0.09	Left	Cheek	SAR CDMA - BC15	1:1	0.177	1.156	0.205	
1732.50	450	AWS CDMA	RC3 / SO55	20.7	20.07	0.06	Left	Tilt	SAR CDMA - BC15	1:1	0.060	1.156	0.069	
1732.50	450	AWS CDMA	RC3 / SO55	10.7	10.36	-0.14	Right	Cheek	SAR CDMA - BC15	1:1	0.017	1.081	0.018	
1732.50	450	AWS CDMA	RC3 / SO55	10.7	10.36	0.12	Right	Tilt	SAR CDMA - BC15	1:1	0.003	1.081	0.004	
1732.50	450	AWS CDMA	RC3 / SO55	10.7	10.36	0.12	Left	Cheek	SAR CDMA - BC15	1:1	0.010	1.081	0.010	
1732.50	450	AWS CDMA	RC3 / SO55	10.7	10.36	0.19	Left	Tilt	SAR CDMA - BC15	1:1	0.003	1.081	0.003	
1732.50	450	AWS CDMA	EVDO Rev. A	24.2	23.84	0.01	Right	Cheek	SAR CDMA - BC15	1:1	0.664	1.086	0.721	
1732.50	450	AWS CDMA	EVDO Rev. A	24.2	23.84	0.05	Right	Tilt	SAR CDMA - BC15	1:1	0.157	1.086	0.171	
1732.50	450	AWS CDMA	EVDO Rev. A	24.2	23.84	0.03	Left	Cheek	SAR CDMA - BC15	1:1	0.419	1.086	0.455	
1732.50	450	AWS CDMA	EVDO Rev. A	24.2	23.84	0.08	Left	Tilt	SAR CDMA - BC15	1:1	0.137	1.086	0.149	
ANSI / IEEE C95.1 1992 - SAFETY LIMIT Spatial Peak Uncontrolled Exposure/General Population							Head 1.6 W/kg (mW/g) averaged over 1 gram							

FCC ID: V65C6721A1	 PCTEST ENGINEERING LABORATORY, INC.	SAR EVALUATION REPORT	 KYOCERA	Reviewed by: Quality Manager
Document S/N: OY1212071742-R4.V65	Test Dates: 12/10/12 - 02/22/13	DUT Type: Portable Handset	Page 53 of 82	



**Table 12-3  
PCS CDMA Head SAR Data**

MEASUREMENT RESULTS														
FREQUENCY		Mode/Band	Service	Maximum Allowed Power [dBm]	Conducted Power [dBm]	Power Drift [dB]	Side	Test Position	Device Serial Number	Duty Cycle	SAR (1g)	Scaling Factor	Scaled SAR (1g)	Plot #
MHz	Ch.										(W/kg)		(W/kg)	
1851.25	25	PCS CDMA	RC3 / SO55	24.2	23.70	-0.13	Right	Cheek	SAR CDMA - BC1	1:1	0.713	1.122	0.800	
1880.00	600	PCS CDMA	RC3 / SO55	24.2	23.89	-0.02	Right	Cheek	SAR CDMA - BC1	1:1	0.880	1.074	0.945	A3
1908.75	1175	PCS CDMA	RC3 / SO55	24.2	23.79	-0.06	Right	Cheek	SAR CDMA - BC1	1:1	0.567	1.099	0.623	
1880.00	600	PCS CDMA	RC3 / SO55	24.2	23.89	0.09	Right	Tilt	SAR CDMA - BC1	1:1	0.195	1.074	0.209	
1880.00	600	PCS CDMA	RC3 / SO55	24.2	23.89	-0.04	Left	Cheek	SAR CDMA - BC1	1:1	0.592	1.074	0.636	
1880.00	600	PCS CDMA	RC3 / SO55	24.2	23.89	0.03	Left	Tilt	SAR CDMA - BC1	1:1	0.253	1.074	0.272	
1880.00	600	PCS CDMA	RC3 / SO55	20.7	20.35	-0.03	Right	Cheek	SAR CDMA - BC1	1:1	0.461	1.084	0.500	
1880.00	600	PCS CDMA	RC3 / SO55	20.7	20.35	0.19	Right	Tilt	SAR CDMA - BC1	1:1	0.087	1.084	0.094	
1880.00	600	PCS CDMA	RC3 / SO55	20.7	20.35	0.07	Left	Cheek	SAR CDMA - BC1	1:1	0.283	1.084	0.307	
1880.00	600	PCS CDMA	RC3 / SO55	20.7	20.35	-0.03	Left	Tilt	SAR CDMA - BC1	1:1	0.102	1.084	0.111	
1851.25	25	PCS CDMA	RC3 / SO55	10.7	10.48	-0.14	Right	Cheek	SAR CDMA - BC1	1:1	0.036	1.052	0.038	
1851.25	25	PCS CDMA	RC3 / SO55	10.7	10.48	0.12	Right	Tilt	SAR CDMA - BC1	1:1	0.005	1.052	0.006	
1851.25	25	PCS CDMA	RC3 / SO55	10.7	10.48	0.07	Left	Cheek	SAR CDMA - BC1	1:1	0.021	1.052	0.022	
1851.25	25	PCS CDMA	RC3 / SO55	10.7	10.48	0.12	Left	Tilt	SAR CDMA - BC1	1:1	0.008	1.052	0.008	
1851.25	25	PCS CDMA	EVDO Rev. A	24.2	23.71	-0.14	Right	Cheek	SAR CDMA - BC1	1:1	0.594	1.119	0.665	
1880.00	600	PCS CDMA	EVDO Rev. A	24.2	23.78	-0.12	Right	Cheek	SAR CDMA - BC1	1:1	0.760	1.102	0.838	
1908.75	1175	PCS CDMA	EVDO Rev. A	24.2	23.88	-0.09	Right	Cheek	SAR CDMA - BC1	1:1	0.539	1.076	0.580	
1880.00	600	PCS CDMA	EVDO Rev. A	24.2	23.78	0.08	Right	Tilt	SAR CDMA - BC1	1:1	0.125	1.102	0.138	
1880.00	600	PCS CDMA	EVDO Rev. A	24.2	23.78	0.01	Left	Cheek	SAR CDMA - BC1	1:1	0.496	1.102	0.547	
1880.00	600	PCS CDMA	EVDO Rev. A	24.2	23.78	0.04	Left	Tilt	SAR CDMA - BC1	1:1	0.225	1.102	0.248	
ANSI / IEEE C95.1 1992 - SAFETY LIMIT Spatial Peak Uncontrolled Exposure/General Population									Head 1.6 W/kg (mW/g) averaged over 1 gram					

**Table 12-4  
LTE Band 12 Head SAR Data**

MEASUREMENT RESULTS																			
FREQUENCY		Mode	Bandwidth [MHz]	Maximum Allowed Power [dBm]	Conducted Power [dBm]	Power Drift [dB]	MPR [dB]	Side	Test Position	Modulation	RB Size	RB Offset	Device Serial Number	Duty Cycle	SAR (1g)	Scaling Factor	Scaled SAR (1g)	Plot #	
MHz	Ch.														(W/kg)		(W/kg)		
707.50	23095	Mid	LTE Band 12	10	23.7	23.30	0.01	0	Right	Cheek	QPSK	1	0	LTE SAR/HAC	1:1	0.198	1.096	0.217	
707.50	23095	Mid	LTE Band 12	10	22.7	22.09	0.06	1	Right	Cheek	QPSK	25	12	LTE SAR/HAC	1:1	0.188	1.151	0.214	
707.50	23095	Mid	LTE Band 12	10	23.7	23.30	0.03	0	Right	Tilt	QPSK	1	0	LTE SAR/HAC	1:1	0.123	1.096	0.135	
707.50	23095	Mid	LTE Band 12	10	22.7	22.09	0.03	1	Right	Tilt	QPSK	25	12	LTE SAR/HAC	1:1	0.109	1.151	0.125	
707.50	23095	Mid	LTE Band 12	10	23.7	23.30	0.04	0	Left	Cheek	QPSK	1	0	LTE SAR/HAC	1:1	0.364	1.096	0.399	A4
707.50	23095	Mid	LTE Band 12	10	22.7	22.09	0.05	1	Left	Cheek	QPSK	25	12	LTE SAR/HAC	1:1	0.317	1.151	0.365	
707.50	23095	Mid	LTE Band 12	10	23.7	23.30	0.12	0	Left	Tilt	QPSK	1	0	LTE SAR/HAC	1:1	0.152	1.096	0.167	
707.50	23095	Mid	LTE Band 12	10	22.7	22.09	0.02	1	Left	Tilt	QPSK	25	12	LTE SAR/HAC	1:1	0.127	1.151	0.146	
707.50	23095	Mid	LTE Band 12	10	19.7	19.55	0.00	0	Right	Cheek	QPSK	1	25	SAR LTE - Band 5/12/17	1:1	0.170	1.035	0.176	
707.50	23095	Mid	LTE Band 12	10	19.7	19.44	0.04	0	Right	Cheek	QPSK	25	12	SAR LTE - Band 5/12/17	1:1	0.119	1.062	0.126	
707.50	23095	Mid	LTE Band 12	10	19.7	19.55	0.08	0	Right	Tilt	QPSK	1	25	SAR LTE - Band 5/12/17	1:1	0.120	1.035	0.124	
707.50	23095	Mid	LTE Band 12	10	19.7	19.44	0.00	0	Right	Tilt	QPSK	25	12	SAR LTE - Band 5/12/17	1:1	0.089	1.062	0.094	
707.50	23095	Mid	LTE Band 12	10	19.7	19.55	-0.01	0	Left	Cheek	QPSK	1	25	SAR LTE - Band 5/12/17	1:1	0.226	1.035	0.234	
707.50	23095	Mid	LTE Band 12	10	19.7	19.44	-0.11	0	Left	Cheek	QPSK	25	12	SAR LTE - Band 5/12/17	1:1	0.167	1.062	0.177	
707.50	23095	Mid	LTE Band 12	10	19.7	19.55	0.08	0	Left	Tilt	QPSK	1	25	SAR LTE - Band 5/12/17	1:1	0.114	1.035	0.118	
707.50	23095	Mid	LTE Band 12	10	19.7	19.44	0.03	0	Left	Tilt	QPSK	25	12	SAR LTE - Band 5/12/17	1:1	0.084	1.062	0.089	
707.50	23095	Mid	LTE Band 12	10	18.7	17.95	0.09	0	Right	Cheek	QPSK	1	25	SAR LTE - Band 5/12/17	1:1	0.091	1.189	0.109	
707.50	23095	Mid	LTE Band 12	10	18.7	17.90	0.10	0	Right	Cheek	QPSK	25	12	SAR LTE - Band 5/12/17	1:1	0.065	1.202	0.078	
707.50	23095	Mid	LTE Band 12	10	18.7	17.95	0.09	0	Right	Tilt	QPSK	1	25	SAR LTE - Band 5/12/17	1:1	0.058	1.189	0.069	
707.50	23095	Mid	LTE Band 12	10	18.7	17.90	0.11	0	Right	Tilt	QPSK	25	12	SAR LTE - Band 5/12/17	1:1	0.042	1.202	0.050	
707.50	23095	Mid	LTE Band 12	10	18.7	17.95	-0.02	0	Left	Cheek	QPSK	1	25	SAR LTE - Band 5/12/17	1:1	0.149	1.189	0.177	
707.50	23095	Mid	LTE Band 12	10	18.7	17.90	0.00	0	Left	Cheek	QPSK	25	12	SAR LTE - Band 5/12/17	1:1	0.105	1.202	0.126	
707.50	23095	Mid	LTE Band 12	10	18.7	17.95	0.08	0	Left	Tilt	QPSK	1	25	SAR LTE - Band 5/12/17	1:1	0.068	1.189	0.081	
707.50	23095	Mid	LTE Band 12	10	18.7	17.90	0.03	0	Left	Tilt	QPSK	25	12	SAR LTE - Band 5/12/17	1:1	0.050	1.202	0.061	
ANSI / IEEE C95.1 1992 - SAFETY LIMIT Spatial Peak Uncontrolled Exposure/General Population									Head 1.6 W/kg (mW/g) averaged over 1 gram										

**Table 12-5  
LTE Band 17 Head SAR Data**



FCC ID: V65C6721A1		SAR EVALUATION REPORT		Reviewed by: Quality Manager
Document S/N: OY1212071742-R4.V65	Test Dates: 12/10/12 - 02/22/13	DUT Type: Portable Handset		Page 54 of 82

MEASUREMENT RESULTS																			
FREQUENCY		Mode	Bandwidth [MHz]	Maximum Allowed Power [dBm]	Conducted Power [dBm]	Power Drift [dB]	MPR [dB]	Side	Test Position	Modulation	RB Size	RB Offset	Device Serial Number	Duty Cycle	SAR (1g) (W/kg)	Scaling Factor	Scaled SAR (1g) (W/kg)	Plot #	
MHz	Ch.																		
710.00	23790	Mid	LTE Band 17	10	23.7	23.39	0.13	0	Right	Cheek	QPSK	1	0	LTE SAR/HAC	1:1	0.221	1.074	0.237	
710.00	23790	Mid	LTE Band 17	10	22.7	22.24	0.09	1	Right	Cheek	QPSK	25	0	LTE SAR/HAC	1:1	0.150	1.112	0.167	
710.00	23790	Mid	LTE Band 17	10	23.7	23.39	0.18	0	Right	Tilt	QPSK	1	0	LTE SAR/HAC	1:1	0.143	1.074	0.154	
710.00	23790	Mid	LTE Band 17	10	22.7	22.24	0.15	1	Right	Tilt	QPSK	25	0	LTE SAR/HAC	1:1	0.104	1.112	0.116	
710.00	23790	Mid	LTE Band 17	10	23.7	23.39	0.12	0	Left	Cheek	QPSK	1	0	LTE SAR/HAC	1:1	0.419	1.074	0.450	A5
710.00	23790	Mid	LTE Band 17	10	22.7	22.24	0.04	1	Left	Cheek	QPSK	25	0	LTE SAR/HAC	1:1	0.313	1.112	0.348	
710.00	23790	Mid	LTE Band 17	10	23.7	23.39	0.11	0	Left	Tilt	QPSK	1	0	LTE SAR/HAC	1:1	0.153	1.074	0.164	
710.00	23790	Mid	LTE Band 17	10	22.7	22.24	0.07	1	Left	Tilt	QPSK	25	0	LTE SAR/HAC	1:1	0.116	1.112	0.129	
710.00	23790	Mid	LTE Band 17	10	20.2	19.72	-0.03	0	Right	Cheek	QPSK	1	0	SAR LTE - Band 5/12/17	1:1	0.125	1.117	0.140	
710.00	23790	Mid	LTE Band 17	10	20.2	19.36	0.05	0	Right	Cheek	QPSK	25	25	SAR LTE - Band 5/12/17	1:1	0.116	1.213	0.141	
710.00	23790	Mid	LTE Band 17	10	20.2	19.72	-0.15	0	Right	Tilt	QPSK	1	0	SAR LTE - Band 5/12/17	1:1	0.092	1.117	0.103	
710.00	23790	Mid	LTE Band 17	10	20.2	19.36	-0.16	0	Right	Tilt	QPSK	25	25	SAR LTE - Band 5/12/17	1:1	0.089	1.213	0.107	
710.00	23790	Mid	LTE Band 17	10	20.2	19.72	0.03	0	Left	Cheek	QPSK	1	0	SAR LTE - Band 5/12/17	1:1	0.210	1.117	0.235	
710.00	23790	Mid	LTE Band 17	10	20.2	19.36	-0.08	0	Left	Cheek	QPSK	25	25	SAR LTE - Band 5/12/17	1:1	0.201	1.213	0.244	
710.00	23790	Mid	LTE Band 17	10	20.2	19.72	0.15	0	Left	Tilt	QPSK	1	0	SAR LTE - Band 5/12/17	1:1	0.093	1.117	0.104	
710.00	23790	Mid	LTE Band 17	10	20.2	19.36	0.11	0	Left	Tilt	QPSK	25	25	SAR LTE - Band 5/12/17	1:1	0.091	1.213	0.110	
710.00	23790	Mid	LTE Band 17	10	19.2	18.98	0.08	0	Right	Cheek	QPSK	1	49	SAR LTE - Band 5/12/17	1:1	0.072	1.052	0.076	
710.00	23790	Mid	LTE Band 17	10	19.2	18.87	0.20	0	Right	Cheek	QPSK	25	25	SAR LTE - Band 5/12/17	1:1	0.051	1.079	0.055	
710.00	23790	Mid	LTE Band 17	10	19.2	18.98	0.06	0	Right	Tilt	QPSK	1	49	SAR LTE - Band 5/12/17	1:1	0.053	1.052	0.056	
710.00	23790	Mid	LTE Band 17	10	19.2	18.87	0.20	0	Right	Tilt	QPSK	25	25	SAR LTE - Band 5/12/17	1:1	0.031	1.079	0.033	
710.00	23790	Mid	LTE Band 17	10	19.2	18.98	0.00	0	Left	Cheek	QPSK	1	49	SAR LTE - Band 5/12/17	1:1	0.117	1.052	0.123	
710.00	23790	Mid	LTE Band 17	10	19.2	18.87	0.12	0	Left	Cheek	QPSK	25	25	SAR LTE - Band 5/12/17	1:1	0.085	1.079	0.092	
710.00	23790	Mid	LTE Band 17	10	19.2	18.98	0.16	0	Left	Tilt	QPSK	1	49	SAR LTE - Band 5/12/17	1:1	0.051	1.052	0.053	
710.00	23790	Mid	LTE Band 17	10	19.2	18.87	0.13	0	Left	Tilt	QPSK	25	25	SAR LTE - Band 5/12/17	1:1	0.035	1.079	0.038	
ANSI / IEEE C95.1 1992 - SAFETY LIMIT Spatial Peak Uncontrolled Exposure/General Population										Head 1.6 W/kg (mW/g) averaged over 1 gram									

Table 12-6  
LTE Band 5 Head SAR Data

MEASUREMENT RESULTS																			
FREQUENCY		Mode	Bandwidth [MHz]	Maximum Allowed Power [dBm]	Conducted Power [dBm]	Power Drift [dB]	MPR [dB]	Side	Test Position	Modulation	RB Size	RB Offset	Device Serial Number	Duty Cycle	SAR (1g) (W/kg)	Scaling Factor	Scaled SAR (1g) (W/kg)	Plot #	
MHz	Ch.																		
836.50	20525	Mid	LTE Band 5 (Cell)	10	23.7	23.47	-0.05	0	Right	Cheek	QPSK	1	49	LTE SAR/HAC	1:1	0.262	1.054	0.276	
836.50	20525	Mid	LTE Band 5 (Cell)	10	22.7	22.44	0.10	1	Right	Cheek	QPSK	25	12	LTE SAR/HAC	1:1	0.220	1.062	0.234	
836.50	20525	Mid	LTE Band 5 (Cell)	10	23.7	23.47	-0.04	0	Right	Tilt	QPSK	1	49	LTE SAR/HAC	1:1	0.133	1.054	0.140	
836.50	20525	Mid	LTE Band 5 (Cell)	10	22.7	22.44	-0.04	1	Right	Tilt	QPSK	25	12	LTE SAR/HAC	1:1	0.108	1.062	0.115	
836.50	20525	Mid	LTE Band 5 (Cell)	10	23.7	23.47	-0.02	0	Left	Cheek	QPSK	1	49	LTE SAR/HAC	1:1	0.469	1.054	0.494	A6
836.50	20525	Mid	LTE Band 5 (Cell)	10	22.7	22.44	0.07	1	Left	Cheek	QPSK	25	12	LTE SAR/HAC	1:1	0.374	1.062	0.397	
836.50	20525	Mid	LTE Band 5 (Cell)	10	23.7	23.47	0.16	0	Left	Tilt	QPSK	1	49	LTE SAR/HAC	1:1	0.160	1.054	0.169	
836.50	20525	Mid	LTE Band 5 (Cell)	10	22.7	22.44	-0.03	1	Left	Tilt	QPSK	25	12	LTE SAR/HAC	1:1	0.113	1.062	0.120	
836.50	20525	Mid	LTE Band 5 (Cell)	10	20.2	19.64	-0.04	0	Right	Cheek	QPSK	1	25	SAR LTE - Band 5/12/17	1:1	0.120	1.138	0.137	
836.50	20525	Mid	LTE Band 5 (Cell)	10	20.2	19.40	-0.08	0	Right	Cheek	QPSK	25	0	SAR LTE - Band 5/12/17	1:1	0.093	1.202	0.112	
836.50	20525	Mid	LTE Band 5 (Cell)	10	20.2	19.64	-0.04	0	Right	Tilt	QPSK	1	25	SAR LTE - Band 5/12/17	1:1	0.061	1.138	0.069	
836.50	20525	Mid	LTE Band 5 (Cell)	10	20.2	19.40	-0.03	0	Right	Tilt	QPSK	25	0	SAR LTE - Band 5/12/17	1:1	0.046	1.202	0.055	
836.50	20525	Mid	LTE Band 5 (Cell)	10	20.2	19.64	-0.07	0	Left	Cheek	QPSK	1	25	SAR LTE - Band 5/12/17	1:1	0.210	1.138	0.239	
836.50	20525	Mid	LTE Band 5 (Cell)	10	20.2	19.40	0.04	0	Left	Cheek	QPSK	25	0	SAR LTE - Band 5/12/17	1:1	0.158	1.202	0.190	
836.50	20525	Mid	LTE Band 5 (Cell)	10	20.2	19.64	0.09	0	Left	Tilt	QPSK	1	25	SAR LTE - Band 5/12/17	1:1	0.069	1.138	0.078	
836.50	20525	Mid	LTE Band 5 (Cell)	10	20.2	19.40	0.01	0	Left	Tilt	QPSK	25	0	SAR LTE - Band 5/12/17	1:1	0.055	1.202	0.066	
836.50	20525	Mid	LTE Band 5 (Cell)	10	18.7	17.98	-0.09	0	Right	Cheek	QPSK	1	25	SAR LTE - Band 5/12/17	1:1	0.076	1.180	0.089	
836.50	20525	Mid	LTE Band 5 (Cell)	10	18.7	17.92	-0.06	0	Right	Cheek	QPSK	25	12	SAR LTE - Band 5/12/17	1:1	0.063	1.197	0.075	
836.50	20525	Mid	LTE Band 5 (Cell)	10	18.7	17.98	0.04	0	Right	Tilt	QPSK	1	25	SAR LTE - Band 5/12/17	1:1	0.040	1.180	0.047	
836.50	20525	Mid	LTE Band 5 (Cell)	10	18.7	17.92	0.17	0	Right	Tilt	QPSK	25	12	SAR LTE - Band 5/12/17	1:1	0.032	1.197	0.038	
836.50	20525	Mid	LTE Band 5 (Cell)	10	18.7	17.98	-0.02	0	Left	Cheek	QPSK	1	25	SAR LTE - Band 5/12/17	1:1	0.125	1.180	0.148	
836.50	20525	Mid	LTE Band 5 (Cell)	10	18.7	17.92	0.03	0	Left	Cheek	QPSK	25	12	SAR LTE - Band 5/12/17	1:1	0.106	1.197	0.127	
836.50	20525	Mid	LTE Band 5 (Cell)	10	18.7	17.98	-0.02	0	Left	Tilt	QPSK	1	25	SAR LTE - Band 5/12/17	1:1	0.045	1.180	0.053	
836.50	20525	Mid	LTE Band 5 (Cell)	10	18.7	17.92	0.09	0	Left	Tilt	QPSK	25	12	SAR LTE - Band 5/12/17	1:1	0.035	1.197	0.041	
ANSI / IEEE C95.1 1992 - SAFETY LIMIT Spatial Peak Uncontrolled Exposure/General Population										Head 1.6 W/kg (mW/g) averaged over 1 gram									

Table 12-7  
LTE Band 4 Head SAR Data

FCC ID: V65C6721A1	 PCTEST ENGINEERING LABORATORY, INC.	SAR EVALUATION REPORT	 KYOCERA	Reviewed by: Quality Manager
Document S/N: OY1212071742-R4.V65	Test Dates: 12/10/12 - 02/22/13	DUT Type: Portable Handset	Page 55 of 82	



MEASUREMENT RESULTS																			
FREQUENCY		Mode	Bandwidth [MHz]	Maximum Allowed Power [dBm]	Conducted Power [dBm]	Power Drift [dB]	MPR[dB]	Side	Test Position	Modulation	RB Size	RB Offset	Device Serial Number	Duty Cycle	SAR (1g)	Scaling Factor	Scaled SAR (1g)	Plot #	
MHz	Ch.														(W/kg)		(W/kg)		
1715.00	20000	Low	LTE Band 4 (AWS)	10	23.2	22.76	0.05	0	Right	Cheek	QPSK	1	0	SAR LTE - Band4	1:1	0.508	1.107	0.562	
1715.00	20000	Low	LTE Band 4 (AWS)	10	22.2	21.75	0.59	1	Right	Cheek	QPSK	25	12	SAR LTE - Band4	1:1	0.407	1.109	0.451	
1715.00	20000	Low	LTE Band 4 (AWS)	10	23.2	22.76	0.07	0	Right	Tilt	QPSK	1	0	SAR LTE - Band4	1:1	0.169	1.107	0.187	
1715.00	20000	Low	LTE Band 4 (AWS)	10	22.2	21.75	0.04	1	Right	Tilt	QPSK	25	12	SAR LTE - Band4	1:1	0.132	1.109	0.146	
1715.00	20000	Low	LTE Band 4 (AWS)	10	23.2	22.76	-0.07	0	Left	Cheek	QPSK	1	0	SAR LTE - Band4	1:1	0.925	1.107	1.024	
1732.50	20175	Mid	LTE Band 4 (AWS)	10	23.2	22.65	0.03	0	Left	Cheek	QPSK	1	25	SAR LTE - Band4	1:1	1.090	1.135	1.237	
1750.00	20350	High	LTE Band 4 (AWS)	10	23.2	22.63	0.02	0	Left	Cheek	QPSK	1	0	SAR LTE - Band4	1:1	1.110	1.140	1.265	A7
1715.00	20000	Low	LTE Band 4 (AWS)	10	22.2	21.75	0.05	1	Left	Cheek	QPSK	25	12	SAR LTE - Band4	1:1	0.712	1.109	0.790	
1715.00	20000	Low	LTE Band 4 (AWS)	10	22.2	21.51	-0.14	1	Left	Cheek	QPSK	50	0	SAR LTE - Band4	1:1	0.867	1.172	1.016	
1715.00	20000	Low	LTE Band 4 (AWS)	10	23.2	22.76	0.00	0	Left	Tilt	QPSK	1	0	SAR LTE - Band4	1:1	0.163	1.107	0.180	
1715.00	20000	Low	LTE Band 4 (AWS)	10	22.2	21.75	0.01	1	Left	Tilt	QPSK	25	12	SAR LTE - Band4	1:1	0.128	1.109	0.142	
1750.00	20350	High	LTE Band 4 (AWS)	10	19.7	18.88	0.07	0	Right	Cheek	QPSK	1	25	SAR LTE - Band 4	1:1	0.162	1.208	0.196	
1750.00	20350	High	LTE Band 4 (AWS)	10	19.7	18.82	-0.08	0	Right	Cheek	QPSK	25	0	SAR LTE - Band 4	1:1	0.128	1.225	0.157	
1750.00	20350	High	LTE Band 4 (AWS)	10	19.7	18.88	0.14	0	Right	Tilt	QPSK	1	25	SAR LTE - Band 4	1:1	0.061	1.208	0.073	
1750.00	20350	High	LTE Band 4 (AWS)	10	19.7	18.82	0.09	0	Right	Tilt	QPSK	25	0	SAR LTE - Band 4	1:1	0.047	1.225	0.058	
1750.00	20350	High	LTE Band 4 (AWS)	10	19.7	18.88	0.02	0	Left	Cheek	QPSK	1	25	SAR LTE - Band 4	1:1	0.400	1.208	0.483	
1750.00	20350	High	LTE Band 4 (AWS)	10	19.7	18.82	0.00	0	Left	Cheek	QPSK	25	0	SAR LTE - Band 4	1:1	0.319	1.225	0.391	
1750.00	20350	High	LTE Band 4 (AWS)	10	19.7	18.88	0.13	0	Left	Tilt	QPSK	1	25	SAR LTE - Band 4	1:1	0.055	1.208	0.066	
1750.00	20350	High	LTE Band 4 (AWS)	10	19.7	18.82	0.14	0	Left	Tilt	QPSK	25	0	SAR LTE - Band 4	1:1	0.044	1.225	0.054	
1732.50	20175	Mid	LTE Band 4 (AWS)	10	15.7	15.07	0.04	0	Right	Cheek	QPSK	1	0	SAR LTE - Band4	1:1	0.089	1.156	0.102	
1750.00	20350	High	LTE Band 4 (AWS)	10	15.7	15.14	0.01	0	Right	Cheek	QPSK	25	0	SAR LTE - Band4	1:1	0.069	1.138	0.079	
1732.50	20175	Mid	LTE Band 4 (AWS)	10	15.7	15.07	0.05	0	Right	Tilt	QPSK	1	0	SAR LTE - Band4	1:1	0.031	1.156	0.035	
1750.00	20350	High	LTE Band 4 (AWS)	10	15.7	15.14	-0.09	0	Right	Tilt	QPSK	25	0	SAR LTE - Band4	1:1	0.022	1.138	0.025	
1732.50	20175	Mid	LTE Band 4 (AWS)	10	15.7	15.07	0.13	0	Left	Cheek	QPSK	1	0	SAR LTE - Band4	1:1	0.224	1.156	0.259	
1750.00	20350	High	LTE Band 4 (AWS)	10	15.7	15.14	0.12	0	Left	Cheek	QPSK	25	0	SAR LTE - Band4	1:1	0.170	1.138	0.193	
1732.50	20175	Mid	LTE Band 4 (AWS)	10	15.7	15.07	0.20	0	Left	Tilt	QPSK	1	0	SAR LTE - Band4	1:1	0.025	1.156	0.029	
1750.00	20350	High	LTE Band 4 (AWS)	10	15.7	15.14	0.13	0	Left	Tilt	QPSK	25	0	SAR LTE - Band4	1:1	0.020	1.138	0.022	
1750.00	20350	High	LTE Band 4 (AWS)	10	23.2	22.63	-0.02	0	Left	Cheek	QPSK	1	0	SAR LTE - Band4	1:1	0.947	1.140	1.080	
ANSI / IEEE C95.1 1992 - SAFETY LIMIT Spatial Peak Uncontrolled Exposure/General Population										Head 1.6 W/kg (mW/g) averaged over 1 gram									

Blue entries represent Variability Data.

**Table 12-8  
LTE Band 2 Head SAR Data**

MEASUREMENT RESULTS																			
FREQUENCY		Mode	Bandwidth [MHz]	Maximum Allowed Power [dBm]	Conducted Power [dBm]	Power Drift [dB]	MPR[dB]	Side	Test Position	Modulation	RB Size	RB Offset	Device Serial Number	Duty Cycle	SAR (1g)	Scaling Factor	Scaled SAR (1g)	Plot #	
MHz	Ch.														(W/kg)		(W/kg)		
1880.00	18900	Mid	LTE Band 2 (PCS)	10	23.7	23.49	-0.18	0	Right	Cheek	QPSK	1	0	SAR LTE - Band2	1:1	0.629	1.050	0.660	
1880.00	18900	Mid	LTE Band 2 (PCS)	10	22.7	22.36	0.06	1	Right	Cheek	QPSK	25	12	SAR LTE - Band2	1:1	0.541	1.081	0.585	
1880.00	18900	Mid	LTE Band 2 (PCS)	10	23.7	23.49	-0.07	0	Right	Tilt	QPSK	1	0	SAR LTE - Band2	1:1	0.289	1.050	0.303	
1880.00	18900	Mid	LTE Band 2 (PCS)	10	22.7	22.36	0.01	1	Right	Tilt	QPSK	25	12	SAR LTE - Band2	1:1	0.197	1.081	0.213	
1855.00	18650	Low	LTE Band 2 (PCS)	10	23.7	23.17	0.01	0	Left	Cheek	QPSK	1	25	SAR LTE - Band2	1:1	0.847	1.130	0.957	
1880.00	18900	Mid	LTE Band 2 (PCS)	10	23.7	23.49	-0.07	0	Left	Cheek	QPSK	1	0	SAR LTE - Band2	1:1	1.060	1.050	1.113	
1905.00	19150	High	LTE Band 2 (PCS)	10	23.7	23.45	-0.02	0	Left	Cheek	QPSK	1	0	SAR LTE - Band2	1:1	1.120	1.059	1.186	A8
1880.00	18900	Mid	LTE Band 2 (PCS)	10	22.7	22.36	0.09	1	Left	Cheek	QPSK	25	12	SAR LTE - Band2	1:1	0.729	1.081	0.788	
1880.00	18900	Mid	LTE Band 2 (PCS)	10	22.7	22.22	-0.01	1	Left	Cheek	QPSK	50	0	SAR LTE - Band2	1:1	0.739	1.117	0.825	
1880.00	18900	Mid	LTE Band 2 (PCS)	10	23.7	23.49	-0.02	0	Left	Tilt	QPSK	1	0	SAR LTE - Band2	1:1	0.240	1.050	0.252	
1880.00	18900	Mid	LTE Band 2 (PCS)	10	22.7	22.36	0.01	1	Left	Tilt	QPSK	25	12	SAR LTE - Band2	1:1	0.168	1.081	0.182	
1880.00	18900	Mid	LTE Band 2 (PCS)	10	19.7	19.17	0.00	0	Right	Cheek	QPSK	1	49	SAR LTE - Band 2	1:1	0.326	1.130	0.368	
1880.00	18900	Mid	LTE Band 2 (PCS)	10	19.7	19.18	-0.01	0	Right	Cheek	QPSK	25	25	SAR LTE - Band 2	1:1	0.241	1.127	0.272	
1880.00	18900	Mid	LTE Band 2 (PCS)	10	19.7	19.17	0.20	0	Right	Tilt	QPSK	1	49	SAR LTE - Band 2	1:1	0.098	1.130	0.110	
1880.00	18900	Mid	LTE Band 2 (PCS)	10	19.7	19.18	0.17	0	Right	Tilt	QPSK	25	25	SAR LTE - Band 2	1:1	0.074	1.127	0.083	
1880.00	18900	Mid	LTE Band 2 (PCS)	10	19.7	19.17	-0.02	0	Left	Cheek	QPSK	1	49	SAR LTE - Band 2	1:1	0.477	1.130	0.539	
1880.00	18900	Mid	LTE Band 2 (PCS)	10	19.7	19.18	0.03	0	Left	Cheek	QPSK	25	25	SAR LTE - Band 2	1:1	0.351	1.127	0.396	
1880.00	18900	Mid	LTE Band 2 (PCS)	10	19.7	19.17	0.21	0	Left	Tilt	QPSK	1	49	SAR LTE - Band 2	1:1	0.105	1.130	0.119	
1880.00	18900	Mid	LTE Band 2 (PCS)	10	19.7	19.18	-0.10	0	Left	Tilt	QPSK	25	25	SAR LTE - Band 2	1:1	0.078	1.127	0.088	
1855.00	18650	Low	LTE Band 2 (PCS)	10	15.7	15.41	0.04	0	Right	Cheek	QPSK	1	49	SAR LTE - Band2	1:1	0.139	1.069	0.149	
1855.00	18650	Low	LTE Band 2 (PCS)	10	15.7	15.50	0.05	0	Right	Cheek	QPSK	25	0	SAR LTE - Band2	1:1	0.114	1.047	0.119	
1855.00	18650	Low	LTE Band 2 (PCS)	10	15.7	15.41	0.12	0	Right	Tilt	QPSK	1	49	SAR LTE - Band2	1:1	0.049	1.069	0.052	
1855.00	18650	Low	LTE Band 2 (PCS)	10	15.7	15.50	0.06	0	Right	Tilt	QPSK	25	0	SAR LTE - Band2	1:1	0.044	1.047	0.046	
1855.00	18650	Low	LTE Band 2 (PCS)	10	15.7	15.41	0.03	0	Left	Cheek	QPSK	1	49	SAR LTE - Band2	1:1	0.187	1.069	0.200	
1855.00	18650	Low	LTE Band 2 (PCS)	10	15.7	15.50	0.06	0	Left	Cheek	QPSK	25	0	SAR LTE - Band2	1:1	0.154	1.047	0.161	
1855.00	18650	Low	LTE Band 2 (PCS)	10	15.7	15.41	0.18	0	Left	Tilt	QPSK	1	49	SAR LTE - Band2	1:1	0.042	1.069	0.045	
1855.00	18650	Low	LTE Band 2 (PCS)	10	15.7	15.50	-0.07	0	Left	Tilt	QPSK	25	0	SAR LTE - Band2	1:1	0.038	1.047	0.039	
1905.00	19150	High	LTE Band 2 (PCS)	10	23.7	23.45	0.03	0	Left	Cheek	QPSK	1	0	SAR LTE - Band2	1:1	1.060	1.059	1.123	
ANSI / IEEE C95.1 1992 - SAFETY LIMIT Spatial Peak Uncontrolled Exposure/General Population										Head 1.6 W/kg (mW/g) averaged over 1 gram									

Blue entries represent Variability Data.





**Table 12-9  
2.4 GHz WLAN Head SAR Data**

MEASUREMENT RESULTS															
FREQUENCY		Mode	Service	Maximum Allowed Power [dBm]	Conducted Power [dBm]	Power Drift [dB]	Side	Test Position	Device Serial Number	Data Rate (Mbps)	Duty Cycle	SAR (1g)	Scaling Factor	Scaled SAR (1g)	Plot #
MHz	Ch.											(W/kg)		(W/kg)	
2437	6	IEEE 802.11b	DSSS	16.7	16.44	0.02	Right	Cheek	WIFI/BT RADIATION	1	1:1	0.295	1.062	0.313	A9
2437	6	IEEE 802.11b	DSSS	16.7	16.44	0.18	Right	Tilt	WIFI/BT RADIATION	1	1:1	0.227	1.062	0.241	
2437	6	IEEE 802.11b	DSSS	16.7	16.44	0.00	Left	Cheek	WIFI/BT RADIATION	1	1:1	0.144	1.062	0.153	
2437	6	IEEE 802.11b	DSSS	16.7	16.44	-0.05	Left	Tilt	WIFI/BT RADIATION	1	1:1	0.125	1.062	0.133	
ANSI / IEEE C95.1 1992 - SAFETY LIMIT Spatial Peak Uncontrolled Exposure/General Population							Head 1.6 W/kg (mW/g) averaged over 1 gram								

## 12.1 Standalone Body-Worn SAR Data

**Table 12-10  
CDMA Body-Worn SAR Data**

MEASUREMENT RESULTS														
FREQUENCY		Mode	Service	Maximum Allowed Power [dBm]	Conducted Power [dBm]	Power Drift [dB]	Spacing	Device Serial Number	Duty Cycle	Side	SAR (1g)	Scaling Factor	Scaled SAR (1g)	Plot #
MHz	Ch.										(W/kg)		(W/kg)	
824.70	1013	Cell. CDMA	TDSO / SO32	25.2	24.54	-0.07	10 mm	SAR CDMA - BC0	1:1	back	0.831	1.164	0.967	A10
836.52	384	Cell. CDMA	TDSO / SO32	25.2	24.57	-0.13	10 mm	SAR CDMA - BC0	1:1	back	0.823	1.156	0.951	
848.31	777	Cell. CDMA	TDSO / SO32	25.2	24.48	0.07	10 mm	SAR CDMA - BC0	1:1	back	0.596	1.180	0.703	
836.52	384	Cell. CDMA	TDSO / SO32	15.7	15.39	0.14	10 mm	SAR CDMA - BC0	1:1	back	0.091	1.074	0.098	
1732.50	450	AWS CDMA	TDSO / SO32	24.2	23.76	0.03	10 mm	SAR CDMA - BC15	1:1	back	0.469	1.107	0.519	A12
1732.50	450	AWS CDMA	TDSO / SO32	20.7	20.01	-0.10	10 mm	SAR CDMA - BC15	1:1	back	0.183	1.172	0.214	
1732.50	450	AWS CDMA	TDSO / SO32	10.7	10.28	0.18	10 mm	SAR CDMA - BC15	1:1	back	0.014	1.102	0.015	
1880.00	600	PCS CDMA	TDSO / SO32	24.2	23.63	0.02	10 mm	SAR CDMA - BC1	1:1	back	0.655	1.140	0.747	A13
1880.00	600	PCS CDMA	TDSO / SO32	20.7	20.37	-0.03	10 mm	SAR CDMA - BC1	1:1	back	0.314	1.079	0.339	
1851.25	25	PCS CDMA	TDSO / SO32	10.7	10.48	0.19	10 mm	SAR CDMA - BC1	1:1	back	0.024	1.052	0.025	
ANSI / IEEE C95.1 1992 - SAFETY LIMIT Spatial Peak Uncontrolled Exposure/General Population							Body 1.6 W/kg (mW/g) averaged over 1 gram							

FCC ID: V65C6721A1	 <b>PCTEST</b> ENGINEERING LABORATORY, INC.	<b>SAR EVALUATION REPORT</b>	 <b>KYOCERA</b>	Reviewed by: Quality Manager
Document S/N: 0Y1212071742-R4.V65	Test Dates: 12/10/12 - 02/22/13	DUT Type: Portable Handset		Page 57 of 82

**Table 12-11**  
**LTE Body-Worn SAR Data**

MEASUREMENT RESULTS																			
FREQUENCY		Mode	Bandwidth [MHz]	Maximum Allowed Power [dBm]	Conducted Power [dBm]	Power Drift [dB]	MPR [dB]	Device Serial Number	Modulation	RB Size	RB Offset	Spacing	Side	Duty Cycle	SAR (1g)	Scaling Factor	Scaled SAR (1g)	Plot #	
MHz	Ch.														(W/kg)		(W/kg)		
707.50	23095	Mid	LTE Band 12	10	23.7	23.30	0.01	0	LTE SAR/HAC	QPSK	1	0	10 mm	back	1.1	0.326	1.096	0.357	A15
707.50	23095	Mid	LTE Band 12	10	22.7	22.09	0.00	1	LTE SAR/HAC	QPSK	25	12	10 mm	back	1.1	0.278	1.151	0.320	
707.50	23095	Mid	LTE Band 12	10	19.7	19.55	0.03	0	SAR LTE - Band 5/12/17	QPSK	1	25	10 mm	back	1.1	0.152	1.035	0.157	
707.50	23095	Mid	LTE Band 12	10	19.7	19.44	0.04	0	SAR LTE - Band 5/12/17	QPSK	25	12	10 mm	back	1.1	0.109	1.062	0.116	
707.50	23095	Mid	LTE Band 12	10	18.7	17.95	0.03	0	SAR LTE - Band 5/12/17	QPSK	1	25	10 mm	back	1.1	0.098	1.189	0.116	
707.50	23095	Mid	LTE Band 12	10	18.7	17.90	0.11	0	SAR LTE - Band 5/12/17	QPSK	25	12	10 mm	back	1.1	0.075	1.202	0.091	
710.00	23790	Mid	LTE Band 17	10	23.7	23.39	0.00	0	LTE SAR/HAC	QPSK	1	0	10 mm	back	1.1	0.370	1.074	0.397	A17
710.00	23790	Mid	LTE Band 17	10	22.7	22.24	0.03	1	LTE SAR/HAC	QPSK	25	0	10 mm	back	1.1	0.261	1.112	0.290	
710.00	23790	Mid	LTE Band 17	10	20.2	19.72	0.02	0	SAR LTE - Band 5/12/17	QPSK	1	0	10 mm	back	1.1	0.127	1.117	0.142	
710.00	23790	Mid	LTE Band 17	10	20.2	19.36	0.01	0	SAR LTE - Band 5/12/17	QPSK	25	25	10 mm	back	1.1	0.128	1.213	0.155	
710.00	23790	Mid	LTE Band 17	10	19.2	18.98	-0.14	0	SAR LTE - Band 5/12/17	QPSK	1	49	10 mm	back	1.1	0.077	1.052	0.081	
710.00	23790	Mid	LTE Band 17	10	19.2	18.87	-0.02	0	SAR LTE - Band 5/12/17	QPSK	25	25	10 mm	back	1.1	0.056	1.079	0.060	
836.50	20525	Mid	LTE Band 5 (Cell)	10	23.7	23.47	-0.05	0	LTE SAR/HAC	QPSK	1	49	10 mm	back	1.1	0.347	1.054	0.366	A19
836.50	20525	Mid	LTE Band 5 (Cell)	10	22.7	22.44	0.03	1	LTE SAR/HAC	QPSK	25	12	10 mm	back	1.1	0.295	1.062	0.313	
836.50	20525	Mid	LTE Band 5 (Cell)	10	20.2	19.64	-0.05	0	SAR LTE - Band 5/12/17	QPSK	1	25	10 mm	back	1.1	0.186	1.138	0.212	
836.50	20525	Mid	LTE Band 5 (Cell)	10	20.2	19.40	0.06	0	SAR LTE - Band 5/12/17	QPSK	25	0	10 mm	back	1.1	0.150	1.202	0.180	
836.50	20525	Mid	LTE Band 5 (Cell)	10	18.7	17.98	0.00	0	SAR LTE - Band 5/12/17	QPSK	1	25	10 mm	back	1.1	0.098	1.180	0.116	
836.50	20525	Mid	LTE Band 5 (Cell)	10	18.7	17.92	0.07	0	SAR LTE - Band 5/12/17	QPSK	25	12	10 mm	back	1.1	0.075	1.197	0.090	
1715.00	20000	Low	LTE Band 4 (AWS)	10	23.2	22.76	0.03	0	SAR LTE - Band 4	QPSK	1	0	10 mm	back	1.1	0.582	1.107	0.644	A21
1715.00	20000	Low	LTE Band 4 (AWS)	10	22.2	21.75	0.11	1	SAR LTE - Band 4	QPSK	25	12	10 mm	back	1.1	0.463	1.109	0.513	
1750.00	20350	High	LTE Band 4 (AWS)	10	19.7	18.88	-0.04	0	SAR LTE - Band 4	QPSK	1	25	10 mm	back	1.1	0.283	1.208	0.342	
1750.00	20350	High	LTE Band 4 (AWS)	10	19.7	18.82	-0.05	0	SAR LTE - Band 4	QPSK	25	0	10 mm	back	1.1	0.223	1.225	0.273	
1732.50	20175	Mid	LTE Band 4 (AWS)	10	15.7	15.07	0.04	0	SAR LTE - Band 4	QPSK	1	0	10 mm	back	1.1	0.128	1.156	0.148	
1750.00	20350	High	LTE Band 4 (AWS)	10	15.7	15.14	0.04	0	SAR LTE - Band 4	QPSK	25	0	10 mm	back	1.1	0.100	1.138	0.114	
1855.00	18650	Low	LTE Band 2 (PCS)	10	23.7	23.17	0.00	0	SAR LTE - Band2	QPSK	1	25	10 mm	back	1.1	0.700	1.130	0.791	
1880.00	18900	Mid	LTE Band 2 (PCS)	10	23.7	23.49	-0.02	0	SAR LTE - Band2	QPSK	1	0	10 mm	back	1.1	0.802	1.050	0.842	A23
1905.00	19150	High	LTE Band 2 (PCS)	10	23.7	23.45	-0.03	0	SAR LTE - Band2	QPSK	1	0	10 mm	back	1.1	0.789	1.059	0.836	
1880.00	18900	Mid	LTE Band 2 (PCS)	10	22.7	22.36	0.07	1	SAR LTE - Band2	QPSK	25	12	10 mm	back	1.1	0.574	1.081	0.620	
1880.00	18900	Mid	LTE Band 2 (PCS)	10	22.7	22.22	-0.04	1	SAR LTE - Band2	QPSK	50	0	10 mm	back	1.1	0.564	1.117	0.630	
1880.00	18900	Mid	LTE Band 2 (PCS)	10	19.7	19.17	-0.01	0	SAR LTE - Band 2	QPSK	1	49	10 mm	back	1.1	0.338	1.130	0.382	
1880.00	18900	Mid	LTE Band 2 (PCS)	10	19.7	19.18	0.02	0	SAR LTE - Band 2	QPSK	25	25	10 mm	back	1.1	0.255	1.127	0.287	
1855.00	18650	Low	LTE Band 2 (PCS)	10	15.7	15.41	-0.05	0	SAR LTE - Band2	QPSK	1	49	10 mm	back	1.1	0.132	1.069	0.141	
1855.00	18650	Low	LTE Band 2 (PCS)	10	15.7	15.50	0.10	0	SAR LTE - Band2	QPSK	25	0	10 mm	back	1.1	0.102	1.047	0.107	
ANSI / IEEE C95.1 1992 - SAFETY LIMIT Spatial Peak Uncontrolled Exposure/General Population									Body 1.6 W/kg (mW/g) averaged over 1 gram										

**Table 12-12**  
**2.4 GHz WLAN Body-Worn SAR Data**



MEASUREMENT RESULTS															
FREQUENCY		Mode	Service	Maximum Allowed Power [dBm]	Conducted Power [dBm]	Power Drift [dB]	Spacing	Device Serial Number	Data Rate (Mbps)	Side	Duty Cycle	SAR (1g)	Scaling Factor	Scaled SAR (1g)	Plot #
MHz	Ch.											(W/kg)		(W/kg)	
2437	6	IEEE 802.11b	DSSS	16.7	16.44	-0.16	10 mm	WIFI/BT RADIATION	1	back	1:1	0.053	1.062	0.056	A25
ANSI / IEEE C95.1 1992 - SAFETY LIMIT Spatial Peak Uncontrolled Exposure/General Population									Body 1.6 W/kg (mW/g) averaged over 1 gram						

## 12.2 Standalone Wireless Router SAR Data

Table 12-13  
CDMA Hotspot SAR Data

MEASUREMENT RESULTS														
FREQUENCY		Mode	Service	Maximum Allowed Power [dBm]	Conducted Power [dBm]	Power Drift [dB]	Spacing	Device Serial Number	Duty Cycle	Side	SAR (1g) (W/kg)	Scaling Factor	Scaled SAR (1g) (W/kg)	Plot #
Mhz	Ch.													
824.70	1013	Cell. CDMA	TDSO / SO32	25.2	24.54	-0.07	10 mm	SAR CDMA - BC0	1:1	back	0.831	1.164	0.967	
836.52	384	Cell. CDMA	TDSO / SO32	25.2	24.57	-0.13	10 mm	SAR CDMA - BC0	1:1	back	0.823	1.156	0.951	
848.31	777	Cell. CDMA	TDSO / SO32	25.2	24.48	0.07	10 mm	SAR CDMA - BC0	1:1	back	0.596	1.180	0.703	
824.70	1013	Cell. CDMA	TDSO / SO32	25.2	24.54	-0.01	10 mm	SAR CDMA - BC0	1:1	front	0.697	1.164	0.811	
836.52	384	Cell. CDMA	TDSO / SO32	25.2	24.57	0.00	10 mm	SAR CDMA - BC0	1:1	front	0.713	1.156	0.824	
848.31	777	Cell. CDMA	TDSO / SO32	25.2	24.48	0.03	10 mm	SAR CDMA - BC0	1:1	front	0.593	1.180	0.700	
836.52	384	Cell. CDMA	TDSO / SO32	25.2	24.57	-0.07	10 mm	SAR CDMA - BC0	1:1	bottom	0.214	1.156	0.247	
836.52	384	Cell. CDMA	TDSO / SO32	25.2	24.57	-0.09	10 mm	SAR CDMA - BC0	1:1	right	0.519	1.156	0.600	
836.52	384	Cell. CDMA	TDSO / SO32	15.7	15.39	0.14	10 mm	SAR CDMA - BC0	1:1	back	0.091	1.074	0.098	
836.52	384	Cell. CDMA	TDSO / SO32	15.7	15.39	0.03	10 mm	SAR CDMA - BC0	1:1	front	0.079	1.074	0.085	
836.52	384	Cell. CDMA	TDSO / SO32	15.7	15.39	0.18	10 mm	SAR CDMA - BC0	1:1	bottom	0.027	1.074	0.029	
836.52	384	Cell. CDMA	TDSO / SO32	15.7	15.39	0.17	10 mm	SAR CDMA - BC0	1:1	right	0.067	1.074	0.072	
824.70	1013	Cell. CDMA	EVDO Rev. 0	25.2	24.68	0.01	10 mm	SAR CDMA - BC0	1:1	back	0.780	1.127	0.879	
836.52	384	Cell. CDMA	EVDO Rev. 0	25.2	24.68	0.03	10 mm	SAR CDMA - BC0	1:1	back	0.840	1.127	0.947	
848.31	777	Cell. CDMA	EVDO Rev. 0	25.2	24.70	0.02	10 mm	SAR CDMA - BC0	1:1	back	0.709	1.122	0.795	
824.70	1013	Cell. CDMA	EVDO Rev. 0	25.2	24.68	0.04	10 mm	SAR CDMA - BC0	1:1	front	0.705	1.127	0.795	
836.52	384	Cell. CDMA	EVDO Rev. 0	25.2	24.68	-0.11	10 mm	SAR CDMA - BC0	1:1	front	0.761	1.127	0.858	
848.31	777	Cell. CDMA	EVDO Rev. 0	25.2	24.70	0.01	10 mm	SAR CDMA - BC0	1:1	front	0.594	1.122	0.666	
836.52	384	Cell. CDMA	EVDO Rev. 0	25.2	24.68	0.00	10 mm	SAR CDMA - BC0	1:1	bottom	0.210	1.127	0.237	
836.52	384	Cell. CDMA	EVDO Rev. 0	25.2	24.68	0.07	10 mm	SAR CDMA - BC0	1:1	right	0.568	1.127	0.640	
836.52	384	Cell. CDMA	EVDO Rev. 0	25.2	24.68	0.04	10 mm	SAR CDMA - BC0	1:1	back	0.906	1.127	1.021	A11
1732.50	450	AWS CDMA	TDSO / SO32	24.2	23.76	0.03	10 mm	SAR CDMA - BC15	1:1	back	0.469	1.107	0.519	A12
1732.50	450	AWS CDMA	TDSO / SO32	24.2	23.76	-0.01	10 mm	SAR CDMA - BC15	1:1	front	0.441	1.107	0.488	
1732.50	450	AWS CDMA	TDSO / SO32	24.2	23.76	0.01	10 mm	SAR CDMA - BC15	1:1	bottom	0.302	1.107	0.334	
1732.50	450	AWS CDMA	TDSO / SO32	24.2	23.76	-0.03	10 mm	SAR CDMA - BC15	1:1	right	0.318	1.107	0.352	
1732.50	450	AWS CDMA	TDSO / SO32	20.7	20.01	-0.10	10 mm	SAR CDMA - BC15	1:1	back	0.183	1.172	0.214	
1732.50	450	AWS CDMA	TDSO / SO32	20.7	20.01	-0.09	10 mm	SAR CDMA - BC15	1:1	front	0.114	1.172	0.134	
1732.50	450	AWS CDMA	TDSO / SO32	20.7	20.01	0.08	10 mm	SAR CDMA - BC15	1:1	bottom	0.084	1.172	0.098	
1732.50	450	AWS CDMA	TDSO / SO32	20.7	20.01	-0.01	10 mm	SAR CDMA - BC15	1:1	right	0.066	1.172	0.077	
1732.50	450	AWS CDMA	TDSO / SO32	10.7	10.28	0.18	10 mm	SAR CDMA - BC15	1:1	back	0.014	1.102	0.015	
1732.50	450	AWS CDMA	TDSO / SO32	10.7	10.28	0.14	10 mm	SAR CDMA - BC15	1:1	front	0.010	1.102	0.011	
1732.50	450	AWS CDMA	TDSO / SO32	10.7	10.28	0.15	10 mm	SAR CDMA - BC15	1:1	bottom	0.010	1.102	0.011	
1732.50	450	AWS CDMA	TDSO / SO32	10.7	10.28	0.15	10 mm	SAR CDMA - BC15	1:1	right	0.004	1.102	0.004	
1732.50	450	AWS CDMA	EVDO Rev. 0	24.2	23.88	0.00	10 mm	SAR CDMA - BC15	1:1	back	0.459	1.076	0.494	
1732.50	450	AWS CDMA	EVDO Rev. 0	24.2	23.88	0.03	10 mm	SAR CDMA - BC15	1:1	front	0.424	1.076	0.456	
1732.50	450	AWS CDMA	EVDO Rev. 0	24.2	23.88	-0.15	10 mm	SAR CDMA - BC15	1:1	bottom	0.307	1.076	0.330	
1732.50	450	AWS CDMA	EVDO Rev. 0	24.2	23.88	0.01	10 mm	SAR CDMA - BC15	1:1	right	0.327	1.076	0.352	
1880.00	600	PCS CDMA	TDSO / SO32	24.2	23.63	0.02	10 mm	SAR CDMA - BC1	1:1	back	0.655	1.140	0.747	
1880.00	600	PCS CDMA	TDSO / SO32	24.2	23.63	-0.08	10 mm	SAR CDMA - BC1	1:1	front	0.870	1.140	0.764	A14
1880.00	600	PCS CDMA	TDSO / SO32	24.2	23.63	0.03	10 mm	SAR CDMA - BC1	1:1	bottom	0.337	1.140	0.384	
1880.00	600	PCS CDMA	TDSO / SO32	24.2	23.63	-0.01	10 mm	SAR CDMA - BC1	1:1	right	0.331	1.140	0.377	
1880.00	600	PCS CDMA	TDSO / SO32	20.7	20.37	-0.03	10 mm	SAR CDMA - BC1	1:1	back	0.314	1.079	0.339	
1880.00	600	PCS CDMA	TDSO / SO32	20.7	20.37	0.00	10 mm	SAR CDMA - BC1	1:1	front	0.296	1.079	0.319	
1880.00	600	PCS CDMA	TDSO / SO32	20.7	20.37	-0.04	10 mm	SAR CDMA - BC1	1:1	bottom	0.137	1.079	0.148	
1880.00	600	PCS CDMA	TDSO / SO32	20.7	20.37	0.05	10 mm	SAR CDMA - BC1	1:1	right	0.109	1.079	0.118	
1851.25	25	PCS CDMA	TDSO / SO32	10.7	10.48	0.19	10 mm	SAR CDMA - BC1	1:1	back	0.024	1.052	0.025	
1851.25	25	PCS CDMA	TDSO / SO32	10.7	10.48	0.18	10 mm	SAR CDMA - BC1	1:1	front	0.021	1.052	0.022	
1851.25	25	PCS CDMA	TDSO / SO32	10.7	10.48	-0.19	10 mm	SAR CDMA - BC1	1:1	bottom	0.008	1.052	0.009	
1851.25	25	PCS CDMA	TDSO / SO32	10.7	10.48	0.03	10 mm	SAR CDMA - BC1	1:1	right	0.007	1.052	0.007	
1880.00	600	PCS CDMA	EVDO Rev. 0	24.2	23.82	-0.03	10 mm	SAR CDMA - BC1	1:1	back	0.665	1.091	0.726	
1880.00	600	PCS CDMA	EVDO Rev. 0	24.2	23.82	-0.04	10 mm	SAR CDMA - BC1	1:1	front	0.640	1.091	0.698	
1880.00	600	PCS CDMA	EVDO Rev. 0	24.2	23.82	0.03	10 mm	SAR CDMA - BC1	1:1	bottom	0.367	1.091	0.400	
1880.00	600	PCS CDMA	EVDO Rev. 0	24.2	23.82	0.00	10 mm	SAR CDMA - BC1	1:1	right	0.315	1.091	0.344	
ANSI / IEEE C95.1 1992 - SAFETY LIMIT Spatial Peak								Body 1.6 W/kg (mW/g) averaged over 1 gram						
Uncontrolled Exposure/General Population														

Blue entries represent Variability Data.

FCC ID: V65C6721A1		SAR EVALUATION REPORT		Reviewed by: Quality Manager
Document S/N: OY1212071742-R4.V65	Test Dates: 12/10/12 - 02/22/13	DUT Type: Portable Handset		Page 59 of 82



**Table 12-14**  
**LTE Band 12 Hotspot SAR Data**

MEASUREMENT RESULTS																			
FREQUENCY		Mode	Bandwidth [MHz]	Maximum Allowed Power [dBm]	Conducted Power [dBm]	Power Drift [dB]	MPR [dB]	Device Serial Number	Modulation	RB Size	RB Offset	Spacing	Side	Duty Cycle	SAR (1g)	Scaling Factor	Scaled SAR (1g)	Plot #	
MHz	Ch.														(W/kg)		(W/kg)		
707.50	23095	Mid	LTE Band 12	10	23.7	23.30	0.01	0	LTE SAR/HAC	QPSK	1	0	10 mm	back	1:1	0.326	1.096	0.357	
707.50	23095	Mid	LTE Band 12	10	22.7	22.09	0.00	1	LTE SAR/HAC	QPSK	25	12	10 mm	back	1:1	0.278	1.151	0.320	
707.50	23095	Mid	LTE Band 12	10	23.7	23.30	0.03	0	LTE SAR/HAC	QPSK	1	0	10 mm	front	1:1	0.253	1.096	0.277	
707.50	23095	Mid	LTE Band 12	10	22.7	22.09	0.06	1	LTE SAR/HAC	QPSK	25	12	10 mm	front	1:1	0.218	1.151	0.251	
707.50	23095	Mid	LTE Band 12	10	23.7	23.30	0.01	0	LTE SAR/HAC	QPSK	1	0	10 mm	bottom	1:1	0.107	1.096	0.117	
707.50	23095	Mid	LTE Band 12	10	22.7	22.09	0.00	1	LTE SAR/HAC	QPSK	25	12	10 mm	bottom	1:1	0.110	1.151	0.127	
707.50	23095	Mid	LTE Band 12	10	23.7	23.30	-0.08	0	LTE SAR/HAC	QPSK	1	0	10 mm	left	1:1	0.357	1.096	0.391	A16
707.50	23095	Mid	LTE Band 12	10	22.7	22.09	-0.03	1	LTE SAR/HAC	QPSK	25	12	10 mm	left	1:1	0.287	1.151	0.330	
707.50	23095	Mid	LTE Band 12	10	19.7	19.55	0.03	0	SAR LTE - Band 5/12/17	QPSK	1	25	10 mm	back	1:1	0.152	1.035	0.157	
707.50	23095	Mid	LTE Band 12	10	19.7	19.44	0.04	0	SAR LTE - Band 5/12/17	QPSK	25	12	10 mm	back	1:1	0.109	1.062	0.116	
707.50	23095	Mid	LTE Band 12	10	19.7	19.55	0.02	0	SAR LTE - Band 5/12/17	QPSK	1	25	10 mm	front	1:1	0.144	1.035	0.149	
707.50	23095	Mid	LTE Band 12	10	19.7	19.44	0.03	0	SAR LTE - Band 5/12/17	QPSK	25	12	10 mm	front	1:1	0.107	1.062	0.114	
707.50	23095	Mid	LTE Band 12	10	19.7	19.55	0.13	0	SAR LTE - Band 5/12/17	QPSK	1	25	10 mm	bottom	1:1	0.044	1.035	0.045	
707.50	23095	Mid	LTE Band 12	10	19.7	19.44	0.03	0	SAR LTE - Band 5/12/17	QPSK	25	12	10 mm	bottom	1:1	0.029	1.062	0.030	
707.50	23095	Mid	LTE Band 12	10	19.7	19.55	0.11	0	SAR LTE - Band 5/12/17	QPSK	1	25	10 mm	left	1:1	0.128	1.035	0.132	
707.50	23095	Mid	LTE Band 12	10	19.7	19.44	0.03	0	SAR LTE - Band 5/12/17	QPSK	25	12	10 mm	left	1:1	0.094	1.062	0.100	
707.50	23095	Mid	LTE Band 12	10	18.7	17.95	0.03	0	SAR LTE - Band 5/12/17	QPSK	1	25	10 mm	back	1:1	0.098	1.189	0.116	
707.50	23095	Mid	LTE Band 12	10	18.7	17.90	0.11	0	SAR LTE - Band 5/12/17	QPSK	25	12	10 mm	back	1:1	0.075	1.202	0.091	
707.50	23095	Mid	LTE Band 12	10	18.7	17.95	0.09	0	SAR LTE - Band 5/12/17	QPSK	1	25	10 mm	front	1:1	0.092	1.189	0.109	
707.50	23095	Mid	LTE Band 12	10	18.7	17.90	0.07	0	SAR LTE - Band 5/12/17	QPSK	25	12	10 mm	front	1:1	0.085	1.202	0.102	
707.50	23095	Mid	LTE Band 12	10	18.7	17.95	0.03	0	SAR LTE - Band 5/12/17	QPSK	1	25	10 mm	bottom	1:1	0.034	1.189	0.040	
707.50	23095	Mid	LTE Band 12	10	18.7	17.90	0.06	0	SAR LTE - Band 5/12/17	QPSK	25	12	10 mm	bottom	1:1	0.023	1.202	0.027	
707.50	23095	Mid	LTE Band 12	10	18.7	17.95	0.02	0	SAR LTE - Band 5/12/17	QPSK	1	25	10 mm	left	1:1	0.105	1.189	0.125	
707.50	23095	Mid	LTE Band 12	10	18.7	17.90	0.03	0	SAR LTE - Band 5/12/17	QPSK	25	12	10 mm	left	1:1	0.079	1.202	0.094	
ANSI / IEEE C95.1 1992 - SAFETY LIMIT Spatial Peak Uncontrolled Exposure/General Population								Body 1.6 W/kg (mW/g) averaged over 1 gram											

**Table 12-15**  
**LTE Band 17 Hotspot SAR Data**

MEASUREMENT RESULTS																			
FREQUENCY		Mode	Bandwidth [MHz]	Maximum Allowed Power [dBm]	Conducted Power [dBm]	Power Drift [dB]	MPR [dB]	Device Serial Number	Modulation	RB Size	RB Offset	Spacing	Side	Duty Cycle	SAR (1g)	Scaling Factor	Scaled SAR (1g)	Plot #	
MHz	Ch.														(W/kg)		(W/kg)		
710.00	23790	Mid	LTE Band 17	10	23.7	23.39	0.00	0	LTE SAR/HAC	QPSK	1	0	10 mm	back	1:1	0.370	1.074	0.397	
710.00	23790	Mid	LTE Band 17	10	22.7	22.24	0.03	1	LTE SAR/HAC	QPSK	25	0	10 mm	back	1:1	0.261	1.112	0.290	
710.00	23790	Mid	LTE Band 17	10	23.7	23.39	0.02	0	LTE SAR/HAC	QPSK	1	0	10 mm	front	1:1	0.319	1.074	0.343	
710.00	23790	Mid	LTE Band 17	10	22.7	22.24	0.05	1	LTE SAR/HAC	QPSK	25	0	10 mm	front	1:1	0.217	1.112	0.241	
710.00	23790	Mid	LTE Band 17	10	23.7	23.39	-0.03	0	LTE SAR/HAC	QPSK	1	0	10 mm	bottom	1:1	0.102	1.074	0.110	
710.00	23790	Mid	LTE Band 17	10	22.7	22.24	0.07	1	LTE SAR/HAC	QPSK	25	0	10 mm	bottom	1:1	0.084	1.112	0.093	
710.00	23790	Mid	LTE Band 17	10	23.7	23.39	0.00	0	LTE SAR/HAC	QPSK	1	0	10 mm	left	1:1	0.388	1.074	0.417	A18
710.00	23790	Mid	LTE Band 17	10	22.7	22.24	0.00	1	LTE SAR/HAC	QPSK	25	0	10 mm	left	1:1	0.265	1.112	0.295	
710.00	23790	Mid	LTE Band 17	10	20.2	19.72	0.02	0	SAR LTE - Band 5/12/17	QPSK	1	0	10 mm	back	1:1	0.127	1.117	0.142	
710.00	23790	Mid	LTE Band 17	10	20.2	19.36	0.01	0	SAR LTE - Band 5/12/17	QPSK	25	25	10 mm	back	1:1	0.128	1.213	0.155	
710.00	23790	Mid	LTE Band 17	10	20.2	19.72	0.05	0	SAR LTE - Band 5/12/17	QPSK	1	0	10 mm	front	1:1	0.109	1.117	0.122	
710.00	23790	Mid	LTE Band 17	10	20.2	19.36	0.13	0	SAR LTE - Band 5/12/17	QPSK	25	25	10 mm	front	1:1	0.117	1.213	0.142	
710.00	23790	Mid	LTE Band 17	10	20.2	19.72	0.08	0	SAR LTE - Band 5/12/17	QPSK	1	0	10 mm	bottom	1:1	0.042	1.117	0.047	
710.00	23790	Mid	LTE Band 17	10	20.2	19.36	-0.04	0	SAR LTE - Band 5/12/17	QPSK	25	25	10 mm	bottom	1:1	0.035	1.213	0.042	
710.00	23790	Mid	LTE Band 17	10	20.2	19.72	0.01	0	SAR LTE - Band 5/12/17	QPSK	1	0	10 mm	left	1:1	0.109	1.117	0.122	
710.00	23790	Mid	LTE Band 17	10	20.2	19.36	-0.03	0	SAR LTE - Band 5/12/17	QPSK	25	25	10 mm	left	1:1	0.097	1.213	0.118	
710.00	23790	Mid	LTE Band 17	10	19.2	18.98	-0.14	0	SAR LTE - Band 5/12/17	QPSK	1	49	10 mm	back	1:1	0.077	1.052	0.081	
710.00	23790	Mid	LTE Band 17	10	19.2	18.87	-0.02	0	SAR LTE - Band 5/12/17	QPSK	25	25	10 mm	back	1:1	0.056	1.079	0.060	
710.00	23790	Mid	LTE Band 17	10	19.2	18.98	0.01	0	SAR LTE - Band 5/12/17	QPSK	1	49	10 mm	front	1:1	0.096	1.052	0.101	
710.00	23790	Mid	LTE Band 17	10	19.2	18.87	-0.02	0	SAR LTE - Band 5/12/17	QPSK	25	25	10 mm	front	1:1	0.048	1.079	0.052	
710.00	23790	Mid	LTE Band 17	10	19.2	18.98	0.01	0	SAR LTE - Band 5/12/17	QPSK	1	49	10 mm	bottom	1:1	0.028	1.052	0.029	
710.00	23790	Mid	LTE Band 17	10	19.2	18.87	-0.03	0	SAR LTE - Band 5/12/17	QPSK	25	25	10 mm	bottom	1:1	0.020	1.079	0.022	
710.00	23790	Mid	LTE Band 17	10	19.2	18.98	-0.04	0	SAR LTE - Band 5/12/17	QPSK	1	49	10 mm	left	1:1	0.067	1.052	0.070	
710.00	23790	Mid	LTE Band 17	10	19.2	18.87	-0.09	0	SAR LTE - Band 5/12/17	QPSK	25	25	10 mm	left	1:1	0.053	1.079	0.057	
ANSI / IEEE C95.1 1992 - SAFETY LIMIT Spatial Peak Uncontrolled Exposure/General Population								Body 1.6 W/kg (mW/g) averaged over 1 gram											

**Table 12-16**  
**LTE Band 5 Hotspot SAR Data**



FCC ID: V65C6721A1	 <b>PCTEST</b> ENGINEERING LABORATORY, INC.	<b>SAR EVALUATION REPORT</b>	 <b>KYOCERA</b>	Reviewed by: Quality Manager
Document S/N: OY1212071742-R4.V65	Test Dates: 12/10/12 - 02/22/13	DUT Type: Portable Handset		Page 60 of 82

MEASUREMENT RESULTS																			
FREQUENCY		Mode	Bandwidth [MHz]	Maximum Allowed Power [dBm]	Conducted Power [dBm]	Power Drift [dB]	MPR [dB]	Device Serial Number	Modulation	RB Size	RB Offset	Spacing	Side	Duty Cycle	SAR (1g)	Scaling Factor	Scaled SAR (1g)	Plot #	
MHz	Ch.														(W/kg)		(W/kg)		
836.50	20525	Mid	LTE Band 5 (Cell)	10	23.7	23.47	-0.05	0	LTE SAR/HAC	QPSK	1	49	10 mm	back	1:1	0.347	1.054	0.366	
836.50	20525	Mid	LTE Band 5 (Cell)	10	22.7	22.44	0.03	1	LTE SAR/HAC	QPSK	25	12	10 mm	back	1:1	0.295	1.062	0.313	
836.50	20525	Mid	LTE Band 5 (Cell)	10	23.7	23.47	-0.07	0	LTE SAR/HAC	QPSK	1	49	10 mm	front	1:1	0.278	1.054	0.293	
836.50	20525	Mid	LTE Band 5 (Cell)	10	22.7	22.44	-0.03	1	LTE SAR/HAC	QPSK	25	12	10 mm	front	1:1	0.228	1.062	0.242	
836.50	20525	Mid	LTE Band 5 (Cell)	10	23.7	23.47	0.08	0	LTE SAR/HAC	QPSK	1	49	10 mm	bottom	1:1	0.116	1.054	0.122	
836.50	20525	Mid	LTE Band 5 (Cell)	10	22.7	22.44	0.06	1	LTE SAR/HAC	QPSK	25	12	10 mm	bottom	1:1	0.095	1.062	0.101	
836.50	20525	Mid	LTE Band 5 (Cell)	10	23.7	23.47	0.02	0	LTE SAR/HAC	QPSK	1	49	10 mm	left	1:1	0.366	1.054	0.386	A20
836.50	20525	Mid	LTE Band 5 (Cell)	10	22.7	22.44	-0.01	1	LTE SAR/HAC	QPSK	25	12	10 mm	left	1:1	0.303	1.062	0.322	
836.50	20525	Mid	LTE Band 5 (Cell)	10	20.2	19.64	-0.05	0	SAR LTE - Band 5/12/17	QPSK	1	25	10 mm	back	1:1	0.186	1.138	0.212	
836.50	20525	Mid	LTE Band 5 (Cell)	10	20.2	19.40	0.06	0	SAR LTE - Band 5/12/17	QPSK	25	0	10 mm	back	1:1	0.150	1.202	0.180	
836.50	20525	Mid	LTE Band 5 (Cell)	10	20.2	19.64	0.10	0	SAR LTE - Band 5/12/17	QPSK	1	25	10 mm	front	1:1	0.142	1.138	0.162	
836.50	20525	Mid	LTE Band 5 (Cell)	10	20.2	19.40	0.02	0	SAR LTE - Band 5/12/17	QPSK	25	0	10 mm	front	1:1	0.114	1.202	0.137	
836.50	20525	Mid	LTE Band 5 (Cell)	10	20.2	19.64	0.03	0	SAR LTE - Band 5/12/17	QPSK	1	25	10 mm	bottom	1:1	0.061	1.138	0.069	
836.50	20525	Mid	LTE Band 5 (Cell)	10	20.2	19.40	-0.03	0	SAR LTE - Band 5/12/17	QPSK	25	0	10 mm	bottom	1:1	0.049	1.202	0.059	
836.50	20525	Mid	LTE Band 5 (Cell)	10	20.2	19.64	-0.02	0	SAR LTE - Band 5/12/17	QPSK	1	25	10 mm	left	1:1	0.183	1.138	0.208	
836.50	20525	Mid	LTE Band 5 (Cell)	10	20.2	19.40	-0.05	0	SAR LTE - Band 5/12/17	QPSK	25	0	10 mm	left	1:1	0.149	1.202	0.179	
836.50	20525	Mid	LTE Band 5 (Cell)	10	18.7	17.98	0.00	0	SAR LTE - Band 5/12/17	QPSK	1	25	10 mm	back	1:1	0.098	1.180	0.116	
836.50	20525	Mid	LTE Band 5 (Cell)	10	18.7	17.92	0.07	0	SAR LTE - Band 5/12/17	QPSK	25	12	10 mm	back	1:1	0.075	1.197	0.090	
836.50	20525	Mid	LTE Band 5 (Cell)	10	18.7	17.98	0.06	0	SAR LTE - Band 5/12/17	QPSK	1	25	10 mm	front	1:1	0.086	1.180	0.101	
836.50	20525	Mid	LTE Band 5 (Cell)	10	18.7	17.92	0.04	0	SAR LTE - Band 5/12/17	QPSK	25	12	10 mm	front	1:1	0.069	1.197	0.082	
836.50	20525	Mid	LTE Band 5 (Cell)	10	18.7	17.98	-0.16	0	SAR LTE - Band 5/12/17	QPSK	1	25	10 mm	bottom	1:1	0.035	1.180	0.041	
836.50	20525	Mid	LTE Band 5 (Cell)	10	18.7	17.92	0.07	0	SAR LTE - Band 5/12/17	QPSK	25	12	10 mm	bottom	1:1	0.029	1.197	0.035	
836.50	20525	Mid	LTE Band 5 (Cell)	10	18.7	17.98	-0.17	0	SAR LTE - Band 5/12/17	QPSK	1	25	10 mm	left	1:1	0.123	1.180	0.145	
836.50	20525	Mid	LTE Band 5 (Cell)	10	18.7	17.92	0.04	0	SAR LTE - Band 5/12/17	QPSK	25	12	10 mm	left	1:1	0.100	1.197	0.119	
ANSI / IEEE C95.1 1992 - SAFETY LIMIT Spatial Peak Uncontrolled Exposure/General Population								Body 1.6 W/kg (mW/g) averaged over 1 gram											

**Table 12-17**  
**LTE Band 4 Hotspot SAR Data**

MEASUREMENT RESULTS																			
FREQUENCY		Mode	Bandwidth [MHz]	Maximum Allowed Power [dBm]	Conducted Power [dBm]	Power Drift [dB]	MPR [dB]	Device Serial Number	Modulation	RB Size	RB Offset	Spacing	Side	Duty Cycle	SAR (1g)	Scaling Factor	Scaled SAR (1g)	Plot #	
MHz	Ch.														(W/kg)		(W/kg)		
1715.00	20000	Low	LTE Band 4 (AWS)	10	23.2	22.76	0.03	0	SAR LTE - Band 4	QPSK	1	0	10 mm	back	1:1	0.582	1.107	0.644	
1715.00	20000	Low	LTE Band 4 (AWS)	10	22.2	21.75	0.11	1	SAR LTE - Band 4	QPSK	25	12	10 mm	back	1:1	0.463	1.109	0.513	
1715.00	20000	Low	LTE Band 4 (AWS)	10	23.2	22.76	-0.04	0	SAR LTE - Band 4	QPSK	1	0	10 mm	front	1:1	0.625	1.107	0.692	A22
1715.00	20000	Low	LTE Band 4 (AWS)	10	22.2	21.75	0.00	1	SAR LTE - Band 4	QPSK	25	12	10 mm	front	1:1	0.494	1.109	0.548	
1715.00	20000	Low	LTE Band 4 (AWS)	10	23.2	22.76	-0.01	0	SAR LTE - Band 4	QPSK	1	0	10 mm	bottom	1:1	0.146	1.107	0.162	
1715.00	20000	Low	LTE Band 4 (AWS)	10	22.2	21.75	-0.04	1	SAR LTE - Band 4	QPSK	25	12	10 mm	bottom	1:1	0.114	1.109	0.126	
1715.00	20000	Low	LTE Band 4 (AWS)	10	23.2	22.76	0.21	0	SAR LTE - Band 4	QPSK	1	0	10 mm	left	1:1	0.191	1.107	0.211	
1715.00	20000	Low	LTE Band 4 (AWS)	10	22.2	21.75	-0.03	1	SAR LTE - Band 4	QPSK	25	12	10 mm	left	1:1	0.152	1.109	0.169	
1750.00	20350	High	LTE Band 4 (AWS)	10	19.7	18.88	-0.04	0	SAR LTE - Band 4	QPSK	1	25	10 mm	back	1:1	0.283	1.208	0.342	
1750.00	20350	High	LTE Band 4 (AWS)	10	19.7	18.82	-0.05	0	SAR LTE - Band 4	QPSK	25	0	10 mm	back	1:1	0.223	1.225	0.273	
1750.00	20350	High	LTE Band 4 (AWS)	10	19.7	18.88	-0.01	0	SAR LTE - Band 4	QPSK	1	25	10 mm	front	1:1	0.237	1.208	0.286	
1750.00	20350	High	LTE Band 4 (AWS)	10	19.7	18.82	-0.07	0	SAR LTE - Band 4	QPSK	25	0	10 mm	front	1:1	0.187	1.225	0.229	
1750.00	20350	High	LTE Band 4 (AWS)	10	19.7	18.88	-0.06	0	SAR LTE - Band 4	QPSK	1	25	10 mm	bottom	1:1	0.067	1.208	0.081	
1750.00	20350	High	LTE Band 4 (AWS)	10	19.7	18.82	-0.02	0	SAR LTE - Band 4	QPSK	25	0	10 mm	bottom	1:1	0.055	1.225	0.067	
1750.00	20350	High	LTE Band 4 (AWS)	10	19.7	18.88	-0.07	0	SAR LTE - Band 4	QPSK	1	25	10 mm	left	1:1	0.091	1.208	0.110	
1750.00	20350	High	LTE Band 4 (AWS)	10	19.7	18.82	0.05	0	SAR LTE - Band 4	QPSK	25	0	10 mm	left	1:1	0.071	1.225	0.087	
1732.50	20175	Mid	LTE Band 4 (AWS)	10	15.7	15.07	0.04	0	SAR LTE - Band 4	QPSK	1	0	10 mm	back	1:1	0.128	1.156	0.148	
1750.00	20350	High	LTE Band 4 (AWS)	10	15.7	15.14	0.04	0	SAR LTE - Band 4	QPSK	25	0	10 mm	back	1:1	0.100	1.138	0.114	
1732.50	20175	Mid	LTE Band 4 (AWS)	10	15.7	15.07	0.01	0	SAR LTE - Band 4	QPSK	1	0	10 mm	front	1:1	0.131	1.156	0.151	
1750.00	20350	High	LTE Band 4 (AWS)	10	15.7	15.14	0.06	0	SAR LTE - Band 4	QPSK	25	0	10 mm	front	1:1	0.103	1.138	0.117	
1732.50	20175	Mid	LTE Band 4 (AWS)	10	15.7	15.07	0.08	0	SAR LTE - Band 4	QPSK	1	0	10 mm	bottom	1:1	0.029	1.156	0.034	
1750.00	20350	High	LTE Band 4 (AWS)	10	15.7	15.14	0.16	0	SAR LTE - Band 4	QPSK	25	0	10 mm	bottom	1:1	0.022	1.138	0.025	
1732.50	20175	Mid	LTE Band 4 (AWS)	10	15.7	15.07	0.19	0	SAR LTE - Band 4	QPSK	1	0	10 mm	left	1:1	0.046	1.156	0.053	
1750.00	20350	High	LTE Band 4 (AWS)	10	15.7	15.14	0.16	0	SAR LTE - Band 4	QPSK	25	0	10 mm	left	1:1	0.029	1.138	0.032	
ANSI / IEEE C95.1 1992 - SAFETY LIMIT Spatial Peak Uncontrolled Exposure/General Population								Body 1.6 W/kg (mW/g) averaged over 1 gram											

**Table 12-18**  
**LTE Band 2 Hotspot SAR Data**

FCC ID: V65C6721A1	 <b>PCTEST</b> ENGINEERING LABORATORY, INC.	<b>SAR EVALUATION REPORT</b>	 <b>KYOCERA</b>	Reviewed by: Quality Manager
Document S/N: OY1212071742-R4.V65	Test Dates: 12/10/12 - 02/22/13	DUT Type: Portable Handset		Page 61 of 82

MEASUREMENT RESULTS																			
FREQUENCY		Mode	Bandwidth [MHz]	Maximum Allowed Power [dBm]	Conducted Power [dBm]	Power Drift [dB]	MPR [dB]	Device Serial Number	Modulation	RB Size	RB Offset	Spacing	Side	Duty Cycle	SAR (1g) (W/kg)	Scaling Factor	Scaled SAR (1g) (W/kg)	Plot #	
MHz	Ch.																		
1855.00	18650	Low	LTE Band 2 (PCS)	10	23.7	23.17	0.00	0	SAR LTE - Band2	QPSK	1	25	10 mm	back	1:1	0.700	1.130	0.791	
1880.00	18900	Mid	LTE Band 2 (PCS)	10	23.7	23.49	-0.02	0	SAR LTE - Band2	QPSK	1	0	10 mm	back	1:1	0.802	1.050	0.842	
1905.00	19150	High	LTE Band 2 (PCS)	10	23.7	23.45	-0.03	0	SAR LTE - Band2	QPSK	1	0	10 mm	back	1:1	0.789	1.059	0.836	
1880.00	18900	Mid	LTE Band 2 (PCS)	10	22.7	22.36	0.07	1	SAR LTE - Band2	QPSK	25	12	10 mm	back	1:1	0.574	1.081	0.620	
1880.00	18900	Mid	LTE Band 2 (PCS)	10	22.7	22.22	-0.04	1	SAR LTE - Band2	QPSK	50	0	10 mm	back	1:1	0.564	1.117	0.630	
1855.00	18650	Low	LTE Band 2 (PCS)	10	23.7	23.17	0.04	0	SAR LTE - Band2	QPSK	1	25	10 mm	front	1:1	0.741	1.130	0.837	
1880.00	18900	Mid	LTE Band 2 (PCS)	10	23.7	23.49	-0.10	0	SAR LTE - Band2	QPSK	1	0	10 mm	front	1:1	0.830	1.050	0.872	A24
1905.00	19150	High	LTE Band 2 (PCS)	10	23.7	23.45	-0.05	0	SAR LTE - Band2	QPSK	1	0	10 mm	front	1:1	0.770	1.059	0.815	
1880.00	18900	Mid	LTE Band 2 (PCS)	10	22.7	22.36	0.01	1	SAR LTE - Band2	QPSK	25	12	10 mm	front	1:1	0.606	1.081	0.655	
1880.00	18900	Mid	LTE Band 2 (PCS)	10	22.7	22.22	0.06	1	SAR LTE - Band2	QPSK	50	0	10 mm	front	1:1	0.573	1.117	0.640	
1880.00	18900	Mid	LTE Band 2 (PCS)	10	23.7	23.49	0.03	0	SAR LTE - Band2	QPSK	1	0	10 mm	bottom	1:1	0.224	1.050	0.235	
1880.00	18900	Mid	LTE Band 2 (PCS)	10	22.7	22.36	0.00	1	SAR LTE - Band2	QPSK	25	12	10 mm	bottom	1:1	0.172	1.081	0.186	
1880.00	18900	Mid	LTE Band 2 (PCS)	10	23.7	23.49	-0.06	0	SAR LTE - Band2	QPSK	1	0	10 mm	left	1:1	0.353	1.050	0.371	
1880.00	18900	Mid	LTE Band 2 (PCS)	10	22.7	22.36	-0.03	1	SAR LTE - Band2	QPSK	25	12	10 mm	left	1:1	0.274	1.081	0.296	
1880.00	18900	Mid	LTE Band 2 (PCS)	10	19.7	19.17	-0.01	0	SAR LTE - Band 2	QPSK	1	49	10 mm	back	1:1	0.338	1.130	0.382	
1880.00	18900	Mid	LTE Band 2 (PCS)	10	19.7	19.18	0.02	0	SAR LTE - Band 2	QPSK	25	25	10 mm	back	1:1	0.255	1.127	0.287	
1880.00	18900	Mid	LTE Band 2 (PCS)	10	19.7	19.17	0.12	0	SAR LTE - Band 2	QPSK	1	49	10 mm	front	1:1	0.309	1.130	0.349	
1880.00	18900	Mid	LTE Band 2 (PCS)	10	19.7	19.18	-0.03	0	SAR LTE - Band 2	QPSK	25	25	10 mm	front	1:1	0.240	1.127	0.270	
1880.00	18900	Mid	LTE Band 2 (PCS)	10	19.7	19.17	-0.06	0	SAR LTE - Band 2	QPSK	1	49	10 mm	bottom	1:1	0.085	1.130	0.096	
1880.00	18900	Mid	LTE Band 2 (PCS)	10	19.7	19.18	0.00	0	SAR LTE - Band 2	QPSK	25	25	10 mm	bottom	1:1	0.061	1.127	0.069	
1880.00	18900	Mid	LTE Band 2 (PCS)	10	19.7	19.17	0.06	0	SAR LTE - Band 2	QPSK	1	49	10 mm	left	1:1	0.160	1.130	0.181	
1880.00	18900	Mid	LTE Band 2 (PCS)	10	19.7	19.18	-0.13	0	SAR LTE - Band 2	QPSK	25	25	10 mm	left	1:1	0.114	1.127	0.128	
1855.00	18650	Low	LTE Band 2 (PCS)	10	15.7	15.41	-0.05	0	SAR LTE - Band2	QPSK	1	49	10 mm	back	1:1	0.132	1.069	0.141	
1855.00	18650	Low	LTE Band 2 (PCS)	10	15.7	15.50	0.10	0	SAR LTE - Band2	QPSK	25	0	10 mm	back	1:1	0.102	1.047	0.107	
1855.00	18650	Low	LTE Band 2 (PCS)	10	15.7	15.41	-0.19	0	SAR LTE - Band2	QPSK	1	49	10 mm	front	1:1	0.119	1.069	0.127	
1855.00	18650	Low	LTE Band 2 (PCS)	10	15.7	15.50	-0.04	0	SAR LTE - Band2	QPSK	25	0	10 mm	front	1:1	0.091	1.047	0.096	
1855.00	18650	Low	LTE Band 2 (PCS)	10	15.7	15.41	-0.16	0	SAR LTE - Band2	QPSK	1	49	10 mm	bottom	1:1	0.032	1.069	0.034	
1855.00	18650	Low	LTE Band 2 (PCS)	10	15.7	15.50	0.00	0	SAR LTE - Band2	QPSK	25	0	10 mm	bottom	1:1	0.025	1.047	0.026	
1855.00	18650	Low	LTE Band 2 (PCS)	10	15.7	15.41	0.12	0	SAR LTE - Band2	QPSK	1	49	10 mm	left	1:1	0.060	1.069	0.064	
1855.00	18650	Low	LTE Band 2 (PCS)	10	15.7	15.50	-0.07	0	SAR LTE - Band2	QPSK	25	0	10 mm	left	1:1	0.044	1.047	0.046	
ANSI / IEEE C95.1 1992 - SAFETY LIMIT Spatial Peak Uncontrolled Exposure/General Population										Body 1.6 W/kg (mW/g) averaged over 1 gram									

**Table 12-19  
2.4 GHz WLAN Hotspot SAR Data**

MEASUREMENT RESULTS																
FREQUENCY		Mode	Service	Maximum Allowed Power [dBm]	Conducted Power [dBm]	Power Drift [dB]	Spacing	Device Serial Number	Data Rate (Mbps)	Side	Duty Cycle	SAR (1g) (W/kg)	Scaling Factor	Scaled SAR (1g) (W/kg)	Plot #	
MHz	Ch.															
2437	6	IEEE 802.11b	DSSS	16.7	16.44	-0.16	10 mm	WIFI/BT RADIATION	1	back	1:1	0.053	1.062	0.056		
2437	6	IEEE 802.11b	DSSS	16.7	16.44	-0.02	10 mm	WIFI/BT RADIATION	1	front	1:1	0.079	1.062	0.084	A26	
2437	6	IEEE 802.11b	DSSS	16.7	16.44	-0.18	10 mm	WIFI/BT RADIATION	1	top	1:1	0.022	1.062	0.023		
2437	6	IEEE 802.11b	DSSS	16.7	16.44	0.10	10 mm	WIFI/BT RADIATION	1	left	1:1	0.063	1.062	0.067		
ANSI / IEEE C95.1 1992 - SAFETY LIMIT Spatial Peak Uncontrolled Exposure/General Population										Body 1.6 W/kg (mW/g) averaged over 1 gram						



## 12.3 SAR Test Notes

### General Notes:

1. The test data reported are the worst-case SAR values according to test procedures specified in IEEE 1528-2003, FCC/OET Bulletin 65, Supplement C [June 2001] and FCC KDB Publication 447498 D01v05.
2. Batteries are fully charged at the beginning of the SAR measurements. A standard battery was used for all SAR measurements.
3. Liquid tissue depth was at least 15.0 cm for all frequencies.
4. The manufacturer has confirmed that the device(s) tested have the same physical, mechanical and thermal characteristics and are within operational tolerances expected for production units
5. SAR results were scaled to the maximum allowed power to demonstrate compliance per FCC KDB Publication 447498 D01v05.
6. Device was tested using a fixed spacing for body-worn accessory testing. A separation distance of 10 mm was considered because the manufacturer has determined that there will be body-worn accessories available in the marketplace for users to support this separation distance.
7. Per FCC KDB Publication 648474 D04v01, SAR was evaluated without a headset connected to the device. Since the standalone reported SAR was  $\leq 1.2$  W/kg, no additional SAR evaluations using a headset cable were required.
8. Per FCC KDB 865664 D01 v01, variability SAR tests were performed when the measured SAR results for a frequency band were greater than 0.8 W/kg. Repeated SAR measurements are highlighted in the tables above for clarity. Please see Section 14 for variability analysis.
9. During SAR Testing for the Wireless Router conditions per FCC KDB Publication 941225 D06v01, the actual Portable Hotspot operation (with actual simultaneous transmission of a transmitter with WIFI) was not activated (See Section 6.6 for more details).

### CDMA Notes:

1. Head SAR for CDMA2000 mode was tested under RC3/SO55 per FCC KDB Publication 941225 D01v02.
2. Body-Worn SAR was tested with 1x RTT with TDSO / SO32 FCH Only. EVDO and TDSO / SO32 FCH+SCH SAR tests were not required since the average output power was not more than 0.25 dB higher than the TDSO / SO32 FCH only powers, per FCC KDB Publication 941225 D01v02.
3. CDMA Wireless Router SAR is measured using Subtype 0/1 Physical Layer configurations for Rev. 0 according to KDB 941225 D01 procedures for data devices. If the average output power of Subtype 2 for Rev. A is less than the Rev. 0 power levels, then EVDO Rev. A SAR is not required. Otherwise, SAR is measured on the maximum output channel for Rev. A using the exposure configuration that results in the highest SAR for that RF channel in Rev. 0. SAR is not required for 1x RTT for Ev-Do hotspot devices when the maximum average output of each channel is less than 1/4 dB higher than that measured in Subtype 0/1 Physical Layer configurations for Rev. 0.
4. Head SAR was additionally evaluated using EVDO Rev. A to determine compliance for VoIP operations.
5. Per FCC KDB Publication 447498 D01v05, if the reported (scaled) SAR measured at the middle channel or highest output power channel for each test configuration is  $\leq 0.8$  W/kg then testing at the other channels is not required for such test configuration(s). When the maximum output power variation across the required test channels is  $> \frac{1}{2}$  dB, instead of the middle channel, the highest output power channel must be used.
6. CDMA 1x-RTT Hotspot SAR was additionally evaluated for Hotspot exposure to support simultaneous capabilities.

FCC ID: V65C6721A1	 <b>PCTEST</b> ENGINEERING LABORATORY, INC.	<b>SAR EVALUATION REPORT</b>	 <b>KYOCERA</b>	Reviewed by: Quality Manager
Document S/N: 0Y1212071742-R4.V65	Test Dates: 12/10/12 - 02/22/13	DUT Type: Portable Handset	Page 63 of 82	





LTE Notes:

1. LTE Considerations: LTE test configurations are determined according to SAR Evaluation Considerations for LTE Devices in FCC KDB Publication 941225 D05v02r01. Implementation of the general test procedures can be found in Section 8.4.4.
2. MPR is permanently implemented for this device by the manufacturer. The specific manufacturer target MPR is indicated alongside the SAR results. MPR is enabled for this device, according to 3GPP TS36.101 Section 6.2.3 – 6.2.5 under Table 6.2.3-1.
3. A-MPR was disabled for all SAR tests by setting NS=01 on the base station simulator.

WLAN Notes:

1. Justification for reduced test configurations for WIFI channels per KDB Publication 248227 D01v01r02 and October 2012 FCC/TCB Meeting Notes for 2.4 GHz WIFI: Highest average RF output power channel for the lowest data rate was selected for SAR evaluation in 802.11b. Other IEEE 802.11 modes (including 802.11g/n) were not investigated since the average output powers over all channels and data rates were not more than 0.25 dB higher than the tested channel in the lowest data rate of IEEE 802.11b mode.
2. WIFI transmission was verified using an uncalibrated spectrum analyzer.
3. Since the maximum extrapolated peak SAR of the zoom scan for the maximum output channel is <1.6 W/kg and the reported 1g averaged SAR is <0.8 W/kg, SAR testing on other default channels was not required.

FCC ID: V65C6721A1	 <b>PCTEST</b> ENGINEERING LABORATORY, INC.	<b>SAR EVALUATION REPORT</b>	 <b>KYOCERA</b>	Reviewed by: Quality Manager
Document S/N: 0Y1212071742-R4.V65	Test Dates: 12/10/12 - 02/22/13	DUT Type: Portable Handset		Page 64 of 82



# 13 FCC MULTI-TX AND ANTENNA SAR CONSIDERATIONS

## 13.1 Introduction

The following procedures adopted from FCC KDB Publication 447498 D01v05 are applicable to handsets with built-in unlicensed transmitters such as 802.11b/g/n and Bluetooth devices which may simultaneously transmit with the licensed transmitter.

## 13.2 Simultaneous Transmission Procedures

This device contains transmitters that may operate simultaneously. Therefore simultaneous transmission analysis is required. Per FCC KDB 447498 D01v05 IV.C.1.iii, simultaneous transmission SAR test exclusion may be applied when the sum of the 1-g SAR for all the simultaneous transmitting antennas in a specific a physical test configuration is  $\leq 1.6$  W/kg. When standalone SAR is not required to be measured, per FCC KDB 447498 D01v05 4.3.2 2), the following equation must be used to estimate the standalone 1g SAR for simultaneous transmission assessment involving that transmitter.

$$\text{Estimated SAR} = \frac{\sqrt{f(\text{GHz})}}{7.5} * \frac{(\text{Max Power of channel, mW})}{\text{Min. Separation Distance, mm}}$$

**Table 13-1  
Estimated SAR**



Mode	Frequency	Maximum Allowed Power	Separation Distance (Body)	Estimated SAR (Body)
	[MHz]	[dBm]	[mm]	[W/kg]
Bluetooth	2441	2.70	10	<b>0.042</b>

Note: Held-to ear configurations are not applicable to Bluetooth operations and therefore were not considered for simultaneous transmission.

## 13.3 Head SAR Simultaneous Transmission Analysis

**Table 13-2  
Simultaneous Transmission Scenario with 2.4 GHz WLAN (Held to Ear)**

Simult Tx	Configuration	Cell. CDMA SAR (W/kg)	2.4 GHz WLAN SAR (W/kg)	$\Sigma$ SAR (W/kg)	Simult Tx	Configuration	Cell. EVDO SAR (W/kg)	2.4 GHz WLAN SAR (W/kg)	$\Sigma$ SAR (W/kg)
Head SAR	Right Cheek	0.797	0.313	<b>1.110</b>	Head SAR	Right Cheek	0.747	0.313	<b>1.060</b>
	Right Tilt	0.452	0.241	0.693		Right Tilt	0.433	0.241	0.674
	Left Cheek	0.639	0.153	0.792		Left Cheek	0.633	0.153	0.786
	Left Tilt	0.402	0.133	0.535		Left Tilt	0.425	0.133	0.558
Simult Tx	Configuration	AWS CDMA SAR (W/kg)	2.4 GHz WLAN SAR (W/kg)	$\Sigma$ SAR (W/kg)	Simult Tx	Configuration	AWS EVDO SAR (W/kg)	2.4 GHz WLAN SAR (W/kg)	$\Sigma$ SAR (W/kg)
Head SAR	Right Cheek	0.769	0.313	<b>1.082</b>	Head SAR	Right Cheek	0.721	0.313	<b>1.034</b>
	Right Tilt	0.164	0.241	0.405		Right Tilt	0.171	0.241	0.412
	Left Cheek	0.486	0.153	0.639		Left Cheek	0.455	0.153	0.608
	Left Tilt	0.153	0.133	0.286		Left Tilt	0.149	0.133	0.282

FCC ID: V65C6721A1	 <b>PCTEST</b> ENGINEERING LABORATORY, INC.	<b>SAR EVALUATION REPORT</b>	 <b>KYOCERA</b>	Reviewed by: Quality Manager
Document S/N: 0Y1212071742-R4.V65	Test Dates: 12/10/12 - 02/22/13	DUT Type: Portable Handset		Page 65 of 82



Simult Tx	Configuration	PCS CDMA SAR (W/kg)	2.4 GHz WLAN SAR (W/kg)	Σ SAR (W/kg)	Simult Tx	Configuration	PCS EVDO SAR (W/kg)	2.4 GHz WLAN SAR (W/kg)	Σ SAR (W/kg)
Head SAR	Right Cheek	0.945	0.313	<b>1.258</b>	Head SAR	Right Cheek	0.838	0.313	<b>1.151</b>
	Right Tilt	0.209	0.241	0.450		Right Tilt	0.138	0.241	0.379
	Left Cheek	0.636	0.153	0.789		Left Cheek	0.547	0.153	0.700
	Left Tilt	0.272	0.133	0.405		Left Tilt	0.248	0.133	0.381
Simult Tx	Configuration	LTE Band 12 SAR (W/kg)	2.4 GHz WLAN SAR (W/kg)	Σ SAR (W/kg)	Simult Tx	Configuration	LTE Band 17 SAR (W/kg)	2.4 GHz WLAN SAR (W/kg)	Σ SAR (W/kg)
Head SAR	Right Cheek	0.217	0.313	0.530	Head SAR	Right Cheek	0.237	0.313	0.550
	Right Tilt	0.135	0.241	0.376		Right Tilt	0.154	0.241	0.395
	Left Cheek	0.399	0.153	<b>0.552</b>		Left Cheek	0.450	0.153	<b>0.603</b>
	Left Tilt	0.167	0.133	0.300		Left Tilt	0.164	0.133	0.297
Simult Tx	Configuration	LTE Band 5 (Cell) SAR (W/kg)	2.4 GHz WLAN SAR (W/kg)	Σ SAR (W/kg)	Simult Tx	Configuration	LTE Band 4 (AWS) SAR (W/kg)	2.4 GHz WLAN SAR (W/kg)	Σ SAR (W/kg)
Head SAR	Right Cheek	0.276	0.313	0.589	Head SAR	Right Cheek	0.562	0.313	0.875
	Right Tilt	0.140	0.241	0.381		Right Tilt	0.187	0.241	0.428
	Left Cheek	0.494	0.153	<b>0.647</b>		Left Cheek	1.265	0.153	<b>1.418</b>
	Left Tilt	0.169	0.133	0.302		Left Tilt	0.180	0.133	0.313
Simult Tx	Configuration	LTE Band 2 (PCS) SAR (W/kg)	2.4 GHz WLAN SAR (W/kg)	Σ SAR (W/kg)					
Head SAR	Right Cheek	0.660	0.313	0.973					
	Right Tilt	0.303	0.241	0.544					
	Left Cheek	1.186	0.153	<b>1.339</b>					
	Left Tilt	0.252	0.133	0.385					

### 13.4 Body-Worn Simultaneous Transmission Analysis

**Table 13-3**  
Simultaneous Transmission Scenario with 2.4 GHz WLAN (Body-Worn at 10 mm)

Configuration	Mode	CDMA/LTE SAR (W/kg)	2.4 GHz WLAN SAR (W/kg)	Σ SAR (W/kg)
Back Side	Cell. CDMA	0.967	0.056	<b>1.023</b>
Back Side	AWS CDMA	0.519	0.056	0.575
Back Side	PCS CDMA	0.747	0.056	0.803
Back Side	LTE Band 12	0.357	0.056	0.413
Back Side	LTE Band 17	0.397	0.056	0.453
Back Side	LTE Band 5 (Cell)	0.366	0.056	0.422
Back Side	LTE Band 4 (AWS)	0.644	0.056	0.700
Back Side	LTE Band 2 (PCS)	0.842	0.056	0.898

Note: Per KDB 941225, when the maximum output power of each channel in EVDO is less than 0.25 dB higher than measured in TDSO, body SAR for EVDO is not required. Therefore, 1x-RTT CDMA body-worn SAR summations additionally show compliance for EVDO Rev. A VoIP body-worn simultaneous transmission scenarios.

FCC ID: V65C6721A1	 <b>PCTEST</b> ENGINEERING LABORATORY, INC.	<b>SAR EVALUATION REPORT</b>	 <b>KYOCERA</b>	Reviewed by: Quality Manager
Document S/N: OY1212071742-R4.V65	Test Dates: 12/10/12 - 02/22/13	DUT Type: Portable Handset	Page 66 of 82	

**Table 13-4**  
**Simultaneous Transmission Scenario with Bluetooth (Body-Worn at 10 mm)**

Configuration	Mode	CDMA/LTE SAR (W/kg)	Bluetooth SAR (W/kg)	Σ SAR (W/kg)
Back Side	Cell. CDMA	0.967	0.042	<b>1.009</b>
Back Side	AWS CDMA	0.519	0.042	0.561
Back Side	PCS CDMA	0.747	0.042	0.789
Back Side	LTE Band 12	0.357	0.042	0.399
Back Side	LTE Band 17	0.397	0.042	0.439
Back Side	LTE Band 5 (Cell)	0.366	0.042	0.408
Back Side	LTE Band 4 (AWS)	0.644	0.042	0.686
Back Side	LTE Band 2 (PCS)	0.842	0.042	0.884

Note:

1. Per KDB 941225, when the maximum output power of each channel in EVDO is less than 0.25 dB higher than measured in TDSO, body SAR for EVDO is not required. Therefore, 1x-RTT CDMA body-worn SAR summations additionally show compliance for EVDO Rev. A VoIP body-worn simultaneous transmission scenarios.
2. Bluetooth SAR was not required to be measured per FCC KDB 447498. Estimated SAR results were used in the above table to determine simultaneous transmission SAR test exclusion.

### 13.5 Hotspot SAR Simultaneous Transmission Analysis

**Table 13-5**  
**Simultaneous Transmission Scenario (Hotspot at 1.0 cm)**

Simult Tx	Configuration	Cell. EVDO SAR (W/kg)	2.4 GHz WLAN SAR (W/kg)	Σ SAR (W/kg)	Simult Tx	Configuration	AWS EVDO SAR (W/kg)	2.4 GHz WLAN SAR (W/kg)	Σ SAR (W/kg)
Body SAR	Back	1.021	0.056	<b>1.077</b>	Body SAR	Back	0.494	0.056	<b>0.550</b>
	Front	0.858	0.084	0.942		Front	0.456	0.084	0.540
	Top	-	0.023	0.023		Top	-	0.023	0.023
	Bottom	0.237	-	0.237		Bottom	0.330	-	0.330
	Right	0.640	-	0.640		Right	0.352	-	0.352
	Left	-	0.067	0.067		Left	-	0.067	0.067
Body SAR	Back	0.726	0.056	<b>0.782</b>	Body SAR	Back	0.357	0.056	0.413
	Front	0.698	0.084	<b>0.782</b>		Front	0.277	0.084	0.361
	Top	-	0.023	0.023		Top	-	0.023	0.023
	Bottom	0.400	-	0.400		Bottom	0.127	-	0.127
	Right	0.344	-	0.344		Right	-	-	0.000
	Left	-	0.067	0.067		Left	0.391	0.067	<b>0.458</b>
Body SAR	Back	0.397	0.056	0.453	Body SAR	Back	0.366	0.056	0.422
	Front	0.343	0.084	0.427		Front	0.293	0.084	0.377
	Top	-	0.023	0.023		Top	-	0.023	0.023
	Bottom	0.110	-	0.110		Bottom	0.122	-	0.122
	Right	-	-	0.000		Right	-	-	0.000
	Left	0.417	0.067	<b>0.484</b>		Left	0.386	0.067	<b>0.453</b>

Simult Tx	Configuration	LTE Band 4 (AWS) SAR (W/kg)	2.4 GHz WLAN SAR (W/kg)	Σ SAR (W/kg)	Simult Tx	Configuration	LTE Band 2 (PCS) SAR (W/kg)	2.4 GHz WLAN SAR (W/kg)	Σ SAR (W/kg)
Body SAR	Back	0.644	0.056	0.700	Body SAR	Back	0.842	0.056	0.898
	Front	0.692	0.084	<b>0.776</b>		Front	0.872	0.084	<b>0.956</b>
	Top	-	0.023	0.023		Top	-	0.023	0.023
	Bottom	0.162	-	0.162		Bottom	0.235	-	0.235
	Right	-	-	0.000		Right	-	-	0.000
	Left	0.211	0.067	0.278		Left	0.371	0.067	0.438



Per FCC KDB Publication 941225 D06v01, the devices edges with antennas more than 2.5 cm from edge are not required to be evaluated for SAR (“-”).

### 13.6 SVLTE Head SAR Simultaneous Transmission Analysis

**Table 13-6**  
**Simultaneous Transmission Scenario (SVLTE)**

Simult Tx		Configuration	Cell CDMA SAR (W/kg)	LTE Band 12 SAR (W/kg)	2.4 GHz WLAN SAR (W/kg)	Σ SAR (W/kg)		Simult Tx		Configuration	Cell CDMA SAR (W/kg)	LTE Band 17 SAR (W/kg)	2.4 GHz WLAN SAR (W/kg)	Σ SAR (W/kg)	
		Tx Ant	1	2	3	1+2	1+2+3			Tx Ant	1	2	3	1+2	1+2+3
Head SAR		Target Power [dBm]	24.5	23	16			Head SAR		Target Power [dBm]	24.5	23	16		
		Right Cheek	0.797	0.217	0.313	1.014	<b>1.327</b>			Right Cheek	0.797	0.237	0.313	1.034	<b>1.347</b>
		Right Tilt	0.452	0.135	0.241	0.587	0.828			Right Tilt	0.452	0.154	0.241	0.606	0.847
		Left Cheek	0.639	0.399	0.153	1.038	1.191			Left Cheek	0.639	0.450	0.153	1.089	1.242
		Left Tilt	0.402	0.167	0.133	0.569	0.702			Left Tilt	0.402	0.164	0.133	0.566	0.699
Simult Tx	CDMA Power Level [dBm]	Configuration	AWS CDMA SAR (W/kg)	LTE Band 12 SAR (W/kg)	2.4 GHz WLAN SAR (W/kg)	Σ SAR (W/kg)		Simult Tx	CDMA Power Level [dBm]	Configuration	AWS CDMA SAR (W/kg)	LTE Band 17 SAR (W/kg)	2.4 GHz WLAN SAR (W/kg)	Σ SAR (W/kg)	
		Tx Ant	1	2	3	1+2	1+2+3			Tx Ant	1	2	3	1+2	1+2+3
Head SAR	p≥20	Target Power [dBm]	23.5	18	16			Head SAR	p≥20	Target Power [dBm]	23.5	18.5	16		
		Right Cheek	0.769	0.109	0.313	0.878	<b>1.191</b>			Right Cheek	0.769	0.076	0.313	0.845	<b>1.158</b>
		Right Tilt	0.164	0.069	0.241	0.233	0.474			Right Tilt	0.164	0.056	0.241	0.220	0.461
		Left Cheek	0.486	0.177	0.153	0.663	0.816			Left Cheek	0.486	0.123	0.153	0.609	0.762
		Left Tilt	0.153	0.081	0.133	0.234	0.367			Left Tilt	0.153	0.053	0.133	0.206	0.339
	p<20	Target Power [dBm]	20	23	16			Head SAR	p<20	Target Power [dBm]	20	23	16		
		Right Cheek	0.346	0.217	0.313	0.563	0.876			Right Cheek	0.346	0.237	0.313	0.583	0.896
		Right Tilt	0.078	0.135	0.241	0.213	0.454			Right Tilt	0.078	0.154	0.241	0.232	0.473
		Left Cheek	0.205	0.399	0.153	0.604	0.757			Left Cheek	0.205	0.450	0.153	0.655	0.808
		Left Tilt	0.069	0.167	0.133	0.236	0.369			Left Tilt	0.069	0.164	0.133	0.233	0.366
Simult Tx	CDMA Power Level [dBm]	Configuration	PCS CDMA SAR (W/kg)	LTE Band 12 SAR (W/kg)	2.4 GHz WLAN SAR (W/kg)	Σ SAR (W/kg)		Simult Tx	CDMA Power Level [dBm]	Configuration	PCS CDMA SAR (W/kg)	LTE Band 17 SAR (W/kg)	2.4 GHz WLAN SAR (W/kg)	Σ SAR (W/kg)	
		Tx Ant	1	2	3	1+2	1+2+3			Tx Ant	1	2	3	1+2	1+2+3
Head SAR	p≥20	Target Power [dBm]	23.5	19	16			Head SAR	p≥20	Target Power [dBm]	23.5	19.5	16		
		Right Cheek	0.945	0.176	0.313	1.121	<b>1.434</b>			Right Cheek	0.945	0.141	0.313	1.086	<b>1.399</b>
		Right Tilt	0.209	0.124	0.241	0.333	0.574			Right Tilt	0.209	0.107	0.241	0.316	0.557
		Left Cheek	0.636	0.234	0.153	0.870	1.023			Left Cheek	0.636	0.244	0.153	0.880	1.033
		Left Tilt	0.272	0.118	0.133	0.390	0.523			Left Tilt	0.272	0.110	0.133	0.382	0.515
	p<20	Target Power [dBm]	20	23	16			Head SAR	p<20	Target Power [dBm]	20	23	16		
		Right Cheek	0.500	0.217	0.313	0.717	1.030			Right Cheek	0.500	0.237	0.313	0.737	1.050
		Right Tilt	0.094	0.135	0.241	0.229	0.470			Right Tilt	0.094	0.154	0.241	0.248	0.489
		Left Cheek	0.307	0.399	0.153	0.706	0.859			Left Cheek	0.307	0.450	0.153	0.757	0.910
		Left Tilt	0.111	0.167	0.133	0.278	0.411			Left Tilt	0.111	0.164	0.133	0.275	0.408

Simult Tx		Configuration	Cell CDMA SAR (W/kg)	LTE Band 5 SAR (W/kg)	2.4 GHz WLAN SAR (W/kg)	$\Sigma$ SAR (W/kg)		
		Tx Ant	1	2	3			
		Target Power [dBm]	24.5	23	16	1+2	1+2+3	
Head SAR		Right Cheek	0.797	0.276	0.313	1.073	1.386	
		Right Tilt	0.452	0.140	0.241	0.592	0.833	
		Left Cheek	0.639	0.494	0.153	1.133	1.286	
		Left Tilt	0.402	0.169	0.133	0.571	0.704	
Simult Tx	CDMA Power Level [dBm]	Configuration	AWS CDMA SAR (W/kg)	LTE Band 5 SAR (W/kg)	2.4 GHz WLAN SAR (W/kg)	$\Sigma$ SAR (W/kg)		
		Tx Ant	1	2	3			
		Target Power [dBm]	23.5	18	16	1+2	1+2+3	
Head SAR		p $\geq$ 20	Right Cheek	0.769	0.089	0.313	0.858	1.171
			Right Tilt	0.164	0.047	0.241	0.211	0.452
			Left Cheek	0.486	0.148	0.153	0.634	0.787
			Left Tilt	0.153	0.053	0.133	0.206	0.339
		p<20	Target Power [dBm]	20	23	16		
			Right Cheek	0.346	0.276	0.313	0.622	0.935
			Right Tilt	0.078	0.140	0.241	0.218	0.459
			Left Cheek	0.205	0.494	0.153	0.699	0.852
Left Tilt	0.069	0.169	0.133	0.238	0.371			
Simult Tx	CDMA Power Level [dBm]	Configuration	PCS CDMA SAR (W/kg)	LTE Band 5 SAR (W/kg)	2.4 GHz WLAN SAR (W/kg)	$\Sigma$ SAR (W/kg)		
		Tx Ant	1	2	3			
		Target Power [dBm]	23.5	19.5	16	1+2	1+2+3	
Head SAR		p $\geq$ 20	Right Cheek	0.945	0.137	0.313	1.082	1.395
			Right Tilt	0.209	0.069	0.241	0.278	0.519
			Left Cheek	0.636	0.239	0.153	0.875	1.028
			Left Tilt	0.272	0.078	0.133	0.350	0.483
		p<20	Target Power [dBm]	20	23	16		
			Right Cheek	0.500	0.276	0.313	0.776	1.089
			Right Tilt	0.094	0.140	0.241	0.234	0.475
			Left Cheek	0.307	0.494	0.153	0.801	0.954
Left Tilt	0.111	0.169	0.133	0.280	0.413			

FCC ID: V65C6721A1	 <b>PCTEST</b> ENGINEERING LABORATORY, INC.	<b>SAR EVALUATION REPORT</b>	 <b>KYOCERA</b>	Reviewed by: Quality Manager
Document S/N: 0Y1212071742-R4.V65	Test Dates: 12/10/12 - 02/22/13	DUT Type: Portable Handset		Page 69 of 82



Simult Tx	CDMA Power Level [dBm]	Configuration	Cell CDMA SAR (W/kg)	LTE Band 4 SAR (W/kg)	2.4 GHz WLAN SAR (W/kg)	Σ SAR (W/kg)		Simult Tx	CDMA Power Level [dBm]	Configuration	Cell CDMA SAR (W/kg)	LTE Band 2 SAR (W/kg)	2.4 GHz WLAN SAR (W/kg)	Σ SAR (W/kg)		
			1	2	3	1+2	1+2+3				1	2	3	1+2	1+2+3	
Head SAR	p≥15	Target Power [dBm]	24.5	19	16				Head SAR	p≥15	Target Power [dBm]	24.5	19	16		
		Right Cheek	0.797	0.196	0.313	0.993	1.306					0.797	0.368	0.313	1.165	1.478
		Right Tilt	0.452	0.073	0.241	0.525	0.786					0.452	0.110	0.241	0.562	0.803
		Left Cheek	0.639	0.483	0.153	1.122	1.275					0.639	0.539	0.153	1.178	1.331
		Left Tilt	0.402	0.066	0.133	0.468	0.601					0.402	0.119	0.133	0.521	0.654
	p<15	Target Power [dBm]	15	22.5	16				Head SAR	p<15	Target Power [dBm]	15	23	16		
		Right Cheek	0.088	0.562	0.313	0.650	0.983					0.088	0.660	0.313	0.748	1.061
		Right Tilt	0.052	0.187	0.241	0.239	0.480					0.052	0.303	0.241	0.355	0.596
		Left Cheek	0.070	1.265	0.153	1.335	1.488					0.070	1.186	0.153	1.256	1.409
		Left Tilt	0.049	0.180	0.133	0.229	0.362					0.049	0.252	0.133	0.301	0.434
Head SAR	p≥10	Target Power [dBm]	23.5	15	16	1+2	1+2+3		Head SAR	p≥10	Target Power [dBm]	23.5	15	16	1+2	1+2+3
		Right Cheek	0.769	0.102	0.313	0.871	1.184					0.769	0.149	0.313	0.918	1.231
		Right Tilt	0.164	0.035	0.241	0.199	0.440					0.164	0.052	0.241	0.216	0.457
		Left Cheek	0.486	0.259	0.153	0.745	0.898					0.486	0.200	0.153	0.686	0.839
		Left Tilt	0.153	0.029	0.133	0.182	0.315					0.153	0.045	0.133	0.198	0.331
	p<10	Target Power [dBm]	10	22.5	16				Head SAR	p<10	Target Power [dBm]	10	23	16		
		Right Cheek	0.018	0.562	0.313	0.580	0.893					0.018	0.660	0.313	0.678	0.991
		Right Tilt	0.004	0.187	0.241	0.191	0.432					0.004	0.303	0.241	0.307	0.548
		Left Cheek	0.010	1.265	0.153	1.275	1.428					0.010	1.186	0.153	1.196	1.349
		Left Tilt	0.003	0.180	0.133	0.183	0.316					0.003	0.252	0.133	0.255	0.388
Head SAR	p≥10	Target Power [dBm]	23.5	15	16	1+2	1+2+3		Head SAR	p≥10	Target Power [dBm]	23.5	15	16	1+2	1+2+3
		Right Cheek	0.945	0.102	0.313	1.047	1.360					0.945	0.149	0.313	1.094	1.407
		Right Tilt	0.209	0.035	0.241	0.244	0.485					0.209	0.052	0.241	0.261	0.502
		Left Cheek	0.636	0.259	0.153	0.895	1.048					0.636	0.200	0.153	0.836	0.989
		Left Tilt	0.272	0.029	0.133	0.301	0.434					0.272	0.045	0.133	0.317	0.450
	p<10	Target Power [dBm]	10	22.5	16				Head SAR	p<10	Target Power [dBm]	10	23	16		
		Right Cheek	0.038	0.562	0.313	0.600	0.913					0.038	0.660	0.313	0.698	1.011
		Right Tilt	0.006	0.187	0.241	0.193	0.434					0.006	0.303	0.241	0.309	0.550
		Left Cheek	0.022	1.265	0.153	1.287	1.440					0.022	1.186	0.153	1.208	1.361
		Left Tilt	0.008	0.180	0.133	0.188	0.321					0.008	0.252	0.133	0.260	0.393

### 13.7 SVLTE Body-Worn SAR Simultaneous Transmission Analysis

Simult Tx	CDMA Power Level [dBm]	Configuration	Mode	CDMA SAR (W/kg)	LTE Band 12 SAR (W/kg)	2.4 GHz WLAN SAR (W/kg)	Σ SAR (W/kg)	
				1	2	3	1+2	1+2+3
Body-Worn SAR	p≥20	Back	Target Power [dBm]	24.5	23	16		
			Cell CDMA	0.967	0.357	0.056	1.324	1.380
		Back	Target Power [dBm]	23.5	18	16		
			AWS CDMA	0.519	0.116	0.056	0.635	0.691
		Back	Target Power [dBm]	20	23	16		
			AWS CDMA	0.214	0.357	0.056	0.571	0.627
Back	Target Power [dBm]	23.5	19	16				
	PCS CDMA	0.747	0.157	0.056	0.904	0.960		
Body-Worn SAR	p<20	Back	Target Power [dBm]	20	23	16		
			PCS CDMA	0.339	0.357	0.056	0.696	0.752
		Back	Target Power [dBm]	24.5	23	16		
			Cell CDMA	0.967	0.397	0.056	1.364	1.420
		Back	Target Power [dBm]	23.5	18.5	16		
			AWS CDMA	0.519	0.081	0.056	0.600	0.656
Back	Target Power [dBm]	20	23	16				
	AWS CDMA	0.214	0.397	0.056	0.611	0.667		
Back	Target Power [dBm]	23.5	19.5	16				
	PCS CDMA	0.747	0.155	0.056	0.902	0.958		
Back	Target Power [dBm]	20	23	16				
	PCS CDMA	0.339	0.397	0.056	0.736	0.792		

Simult Tx	CDMA Power Level [dBm]	Configuration	Mode	CDMA SAR (W/kg)	LTE Band 5 SAR (W/kg)	2.4 GHz WLAN SAR (W/kg)	$\Sigma$ SAR (W/kg)	
				Tx Ant	1	2	3	1+2
Body-Worn SAR	p $\geq$ 20	Back	Target Power [dBm]	24.5	23	16	1.333	1.389
			Cell CDMA	0.967	0.366	0.056		
	p $<$ 20	Back	Target Power [dBm]	23.5	18	16	0.635	0.691
			AWS CDMA	0.519	0.116	0.056		
	p $\geq$ 20	Back	Target Power [dBm]	20	23	16	0.580	0.636
			AWS CDMA	0.214	0.366	0.056		
	p $<$ 20	Back	Target Power [dBm]	23.5	19.5	16	0.959	1.015
			PCS CDMA	0.747	0.212	0.056		
p $<$ 20	Back	Target Power [dBm]	20	23	16	0.705	0.761	
		PCS CDMA	0.339	0.366	0.056			
Simult Tx	CDMA Power Level [dBm]	Configuration	Mode	CDMA SAR (W/kg)	LTE Band 4 SAR (W/kg)	2.4 GHz WLAN SAR (W/kg)	$\Sigma$ SAR (W/kg)	
				Tx Ant	1	2	3	1+2
Body-Worn SAR	p $\geq$ 15	Back	Target Power [dBm]	24.5	19	16	1.309	1.365
			Cell CDMA	0.967	0.342	0.056		
	p $<$ 15	Back	Target Power [dBm]	15	22.5	16	0.742	0.798
			Cell CDMA	0.098	0.644	0.056		
	p $\geq$ 10	Back	Target Power [dBm]	23.5	15	16	0.667	0.723
			AWS CDMA	0.519	0.148	0.056		
	p $<$ 10	Back	Target Power [dBm]	10	22.5	16	0.659	0.715
			AWS CDMA	0.015	0.644	0.056		
	p $\geq$ 10	Back	Target Power [dBm]	23.5	15	16	0.895	0.951
			PCS CDMA	0.747	0.148	0.056		
	p $<$ 10	Back	Target Power [dBm]	10	22.5	16	0.669	0.725
			PCS CDMA	0.025	0.644	0.056		
Simult Tx	CDMA Power Level [dBm]	Configuration	Mode	CDMA SAR (W/kg)	LTE Band 2 SAR (W/kg)	2.4 GHz WLAN SAR (W/kg)	$\Sigma$ SAR (W/kg)	
				Tx Ant	1	2	3	1+2
Body-Worn SAR	p $\geq$ 15	Back	Target Power [dBm]	24.5	19	16	1.349	1.405
			Cell CDMA	0.967	0.382	0.056		
	p $<$ 15	Back	Target Power [dBm]	15	23	16	0.940	0.996
			Cell CDMA	0.098	0.842	0.056		
	p $\geq$ 10	Back	Target Power [dBm]	23.5	15	16	0.660	0.716
			AWS CDMA	0.519	0.141	0.056		
	p $<$ 10	Back	Target Power [dBm]	10	23	16	0.857	0.913
			AWS CDMA	0.015	0.842	0.056		
	p $\geq$ 10	Back	Target Power [dBm]	23.5	15	16	0.888	0.944
			PCS CDMA	0.747	0.141	0.056		
	p $<$ 10	Back	Target Power [dBm]	10	23	16	0.867	0.923
			PCS CDMA	0.025	0.842	0.056		



Simult Tx	CDMA Power Level [dBm]	Configuration	Mode	CDMA SAR (W/kg)	LTE Band 12 SAR (W/kg)	2.4 GHz Bluetooth SAR (W/kg)	Σ SAR (W/kg)
			Tx Ant	1	2	3	1+2+3
Body-Worn SAR		Back	Target Power [dBm]	24.5	23	2	1.366
			Cell CDMA	0.967	0.357	0.042	1.366
	p≥20	Back	Target Power [dBm]	23.5	18	2	0.677
			AWS CDMA	0.519	0.116	0.042	0.677
	p<20	Back	Target Power [dBm]	20	23	2	0.613
			AWS CDMA	0.214	0.357	0.042	0.613
	p≥20	Back	Target Power [dBm]	23.5	19	2	0.946
			PCS CDMA	0.747	0.157	0.042	0.946
p<20	Back	Target Power [dBm]	20	23	2	0.738	
		PCS CDMA	0.339	0.357	0.042	0.738	
Simult Tx	CDMA Power Level [dBm]	Configuration	Mode	CDMA SAR (W/kg)	LTE Band 17 SAR (W/kg)	2.4 GHz Bluetooth SAR (W/kg)	Σ SAR (W/kg)
Body-Worn SAR		Back	Tx Ant	1	2	3	1+2+3
			Target Power [dBm]	24.5	23	2	1.406
	p≥20	Back	Cell CDMA	0.967	0.397	0.042	1.406
			Target Power [dBm]	23.5	18.5	2	0.642
	p<20	Back	AWS CDMA	0.519	0.081	0.042	0.642
			Target Power [dBm]	20	23	2	0.653
	p≥20	Back	AWS CDMA	0.214	0.397	0.042	0.653
			Target Power [dBm]	23.5	19.5	2	0.944
p<20	Back	PCS CDMA	0.747	0.155	0.042	0.944	
		Target Power [dBm]	20	23	2	0.778	
p<20	Back	PCS CDMA	0.339	0.397	0.042	0.778	
		Target Power [dBm]	20	23	2	0.778	
Simult Tx	CDMA Power Level [dBm]	Configuration	Mode	CDMA SAR (W/kg)	LTE Band 5 SAR (W/kg)	2.4 GHz Bluetooth SAR (W/kg)	Σ SAR (W/kg)
Body-Worn SAR		Back	Tx Ant	1	2	3	1+2+3
			Target Power [dBm]	24.5	23	2	1.375
	p≥20	Back	Cell CDMA	0.967	0.366	0.042	1.375
			Target Power [dBm]	23.5	18	2	0.677
	p<20	Back	AWS CDMA	0.519	0.116	0.042	0.677
			Target Power [dBm]	20	23	2	0.622
	p≥20	Back	AWS CDMA	0.214	0.366	0.042	0.622
			Target Power [dBm]	23.5	19.5	2	1.001
p<20	Back	PCS CDMA	0.747	0.212	0.042	1.001	
		Target Power [dBm]	20	23	2	0.747	
p<20	Back	PCS CDMA	0.339	0.366	0.042	0.747	
		Target Power [dBm]	20	23	2	0.747	

FCC ID: V65C6721A1	 <b>PCTEST</b> ENGINEERING LABORATORY, INC.	<b>SAR EVALUATION REPORT</b>	 <b>KYOCERA</b>	Reviewed by: Quality Manager
Document S/N: 0Y1212071742-R4.V65	Test Dates: 12/10/12 - 02/22/13	DUT Type: Portable Handset	Page 72 of 82	



Simult Tx	CDMA Power Level [dBm]	Configuration	Mode	CDMA SAR (W/kg)	LTE Band 4 SAR (W/kg)	2.4 GHz Bluetooth SAR (W/kg)	Σ SAR (W/kg)
			Tx Ant	1	2	3	
Body-Worn SAR	p≥15		Target Power [dBm]	24.5	19	2	1+2+3
		Back	Cell CDMA	0.967	0.342	0.042	1.351
	p<15		Target Power [dBm]	15	22.5	2	
		Back	Cell CDMA	0.098	0.644	0.042	0.784
	p≥10		Target Power [dBm]	23.5	15	2	
		Back	AWS CDMA	0.519	0.148	0.042	0.709
	p<10		Target Power [dBm]	10	22.5	2	
		Back	AWS CDMA	0.015	0.644	0.042	0.701
	p≥10		Target Power [dBm]	23.5	15	2	
		Back	PCS CDMA	0.747	0.148	0.042	0.937
	p<10		Target Power [dBm]	10	22.5	2	
		Back	PCS CDMA	0.025	0.644	0.042	0.711
Simult Tx	CDMA Power Level [dBm]	Configuration	Mode	CDMA SAR (W/kg)	LTE Band 2 SAR (W/kg)	2.4 GHz Bluetooth SAR (W/kg)	Σ SAR (W/kg)
			Tx Ant	1	2	3	
Body-Worn SAR	p≥15		Target Power [dBm]	24.5	19	2	1+2+3
		Back	Cell CDMA	0.967	0.382	0.042	1.391
	p<15		Target Power [dBm]	15	23	2	
		Back	Cell CDMA	0.098	0.842	0.042	0.982
	p≥10		Target Power [dBm]	23.5	15	2	
		Back	AWS CDMA	0.519	0.141	0.042	0.702
	p<10		Target Power [dBm]	10	23	2	
		Back	AWS CDMA	0.015	0.842	0.042	0.899
	p≥10		Target Power [dBm]	23.5	15	2	
		Back	PCS CDMA	0.747	0.141	0.042	0.930
	p<10		Target Power [dBm]	10	23	2	
		Back	PCS CDMA	0.025	0.842	0.042	0.909



Bluetooth SAR was not required to be measured per FCC KDB 447498. Estimated SAR results were used in the above table to determine simultaneous transmission SAR test exclusion.

FCC ID: V65C6721A1	 <b>PCTEST</b> ENGINEERING LABORATORY, INC.	<b>SAR EVALUATION REPORT</b>	 <b>KYOCERA</b>	Reviewed by: Quality Manager
Document S/N: 0Y1212071742-R4.V65	Test Dates: 12/10/12 - 02/22/13	DUT Type: Portable Handset		Page 73 of 82

### 13.8 SVLTE Hotspot SAR Simultaneous Transmission Analysis

Simult Tx		Configuration	Cell CDMA SAR (W/kg)	LTE Band 12 SAR (W/kg)	2.4 GHz WLAN SAR (W/kg)	Σ SAR (W/kg)	Simult Tx		Configuration	Cell CDMA SAR (W/kg)	LTE Band 17 SAR (W/kg)	2.4 GHz WLAN SAR (W/kg)	Σ SAR (W/kg)		
		Tx Ant	1	2	3	1+2+3			Tx Ant	1	2	3	1+2+3		
Hotspot SAR		Target Power [dBm]	24.5	23	16	1.380	Hotspot SAR		Target Power [dBm]	24.5	23	16	1.420		
		Back	0.967	0.357	0.056	1.185			Back	0.967	0.397	0.056	1.251		
		Front	0.824	0.277	0.084	0.023			Front	0.824	0.343	0.084	0.023		
		Top	-	-	-	0.374			Top	-	-	-	0.357		
		Bottom	0.247	0.127	-	0.600			Bottom	0.247	0.110	-	0.600		
		Right	0.600	-	-	0.458			Right	0.600	-	-	0.484		
		Left	-	0.391	0.067				Left	-	0.417	0.067			
Simult Tx		Configuration	AWS CDMA SAR (W/kg)	LTE Band 12 SAR (W/kg)	2.4 GHz WLAN SAR (W/kg)	Σ SAR (W/kg)	Simult Tx		Configuration	AWS CDMA SAR (W/kg)	LTE Band 17 SAR (W/kg)	2.4 GHz WLAN SAR (W/kg)	Σ SAR (W/kg)		
		Tx Ant	1	2	3	1+2+3			Tx Ant	1	2	3	1+2+3		
Hotspot SAR		p≥20	Target Power [dBm]	23.5	18	16	0.691	Hotspot SAR		p≥20	Target Power [dBm]	23.5	18.5	16	
			Back	0.519	0.116	0.056	0.681				Back	0.519	0.081	0.056	0.656
			Front	0.488	0.109	0.084	0.023				Front	0.488	0.101	0.084	0.023
			Top	-	-	-	0.374				Top	-	-	-	0.363
			Bottom	0.334	0.040	-	0.352				Bottom	0.334	0.029	-	0.352
			Right	0.352	-	-	0.192				Right	0.352	-	-	0.137
			Left	-	0.125	0.067					Left	-	0.070	0.067	
		p<20	Target Power [dBm]	20	23	16	0.627	Hotspot SAR		p<20	Target Power [dBm]	20	23	16	
			Back	0.214	0.357	0.056	0.495				Back	0.214	0.397	0.056	0.561
			Front	0.134	0.277	0.084	0.023				Front	0.134	0.343	0.084	0.023
			Top	-	-	-	0.225				Top	-	-	-	0.208
			Bottom	0.098	0.127	-	0.077				Bottom	0.098	0.110	-	0.077
			Right	0.077	-	-	0.458				Right	0.077	-	-	0.484
			Left	-	0.391	0.067					Left	-	0.417	0.067	
Simult Tx		Configuration	PCS CDMA SAR (W/kg)	LTE Band 12 SAR (W/kg)	2.4 GHz WLAN SAR (W/kg)	Σ SAR (W/kg)	Simult Tx		Configuration	PCS CDMA SAR (W/kg)	LTE Band 17 SAR (W/kg)	2.4 GHz WLAN SAR (W/kg)	Σ SAR (W/kg)		
		Tx Ant	1	2	3	1+2+3			Tx Ant	1	2	3	1+2+3		
Hotspot SAR		p≥20	Target Power [dBm]	23.5	19	16	0.960	Hotspot SAR		p≥20	Target Power [dBm]	23.5	19.5	16	
			Back	0.747	0.157	0.056	0.997				Back	0.747	0.155	0.056	0.958
			Front	0.764	0.149	0.084	0.023				Front	0.764	0.142	0.084	0.023
			Top	-	-	-	0.429				Top	-	-	-	0.431
			Bottom	0.384	0.045	-	0.377				Bottom	0.384	0.047	-	0.377
			Right	0.377	-	-	0.199				Right	0.377	-	-	0.189
			Left	-	0.132	0.067					Left	-	0.122	0.067	
		p<20	Target Power [dBm]	20	23	16	0.752	Hotspot SAR		p<20	Target Power [dBm]	20	23	16	
			Back	0.339	0.357	0.056	0.680				Back	0.339	0.397	0.056	0.792
			Front	0.319	0.277	0.084	0.023				Front	0.319	0.343	0.084	0.023
			Top	-	-	-	0.275				Top	-	-	-	0.258
			Bottom	0.148	0.127	-	0.118				Bottom	0.148	0.110	-	0.118
			Right	0.118	-	-	0.458				Right	0.118	-	-	0.484
			Left	-	0.391	0.067					Left	-	0.417	0.067	

Simult Tx		Configuration	Cell CDMA SAR (W/kg)	LTE Band 5 SAR (W/kg)	2.4 GHz WLAN SAR (W/kg)	Σ SAR (W/kg)
		Tx Ant	1	2	3	1+2+3
		Target Power [dBm]	24.5	23	16	
Hotspot SAR		Back	0.967	0.366	0.056	1.389
		Front	0.824	0.293	0.084	1.201
		Top	-	-	0.023	0.023
		Bottom	0.247	0.122	-	0.369
		Right	0.600	-	-	0.600
		Left	-	0.386	0.067	0.453
Simult Tx	CDMA Power Level [dBm]	Configuration	AWS CDMA SAR (W/kg)	LTE Band 5 SAR (W/kg)	2.4 GHz WLAN SAR (W/kg)	Σ SAR (W/kg)
		Tx Ant	1	2	3	1+2+3
		Target Power [dBm]	23.5	18	16	
Hotspot SAR		Back	0.519	0.116	0.056	0.691
		Front	0.488	0.101	0.084	0.673
		Top	-	-	0.023	0.023
		Bottom	0.334	0.041	-	0.375
		Right	0.352	-	-	0.352
		Left	-	0.145	0.067	0.212
		Target Power [dBm]	20	23	16	
Hotspot SAR		Back	0.214	0.366	0.056	0.636
		Front	0.134	0.293	0.084	0.511
		Top	-	-	0.023	0.023
		Bottom	0.098	0.122	-	0.220
		Right	0.077	-	-	0.077
		Left	-	0.386	0.067	0.453
Simult Tx	CDMA Power Level [dBm]	Configuration	PCS CDMA SAR (W/kg)	LTE Band 5 SAR (W/kg)	2.4 GHz WLAN SAR (W/kg)	Σ SAR (W/kg)
		Tx Ant	1	2	3	1+2+3
		Target Power [dBm]	23.5	19.5	16	
Hotspot SAR		Back	0.747	0.212	0.056	1.015
		Front	0.764	0.162	0.084	1.010
		Top	-	-	0.023	0.023
		Bottom	0.384	0.069	-	0.453
		Right	0.377	-	-	0.377
		Left	-	0.208	0.067	0.275
		Target Power [dBm]	20	23	16	
Hotspot SAR		Back	0.339	0.366	0.056	0.761
		Front	0.319	0.293	0.084	0.696
		Top	-	-	0.023	0.023
		Bottom	0.148	0.122	-	0.270
		Right	0.118	-	-	0.118
		Left	-	0.386	0.067	0.453



FCC ID: V65C6721A1	 <b>PCTEST</b> ENGINEERING LABORATORY, INC.	<b>SAR EVALUATION REPORT</b>	 <b>KYOCERA</b>	Reviewed by: Quality Manager
Document S/N: 0Y1212071742-R4.V65	Test Dates: 12/10/12 - 02/22/13	DUT Type: Portable Handset	Page 75 of 82	

Simult Tx	CDMA Power Level [dBm]	Configuration	Cell CDMA SAR (W/kg)	LTE Band 4 SAR (W/kg)	2.4 GHz WLAN SAR (W/kg)	Σ SAR (W/kg)	Simult Tx	CDMA Power Level [dBm]	Configuration	Cell CDMA SAR (W/kg)	LTE Band 2 SAR (W/kg)	2.4 GHz WLAN SAR (W/kg)	Σ SAR (W/kg)
			1	2	3	1+2+3				1	2	3	1+2+3
Hotspot SAR	p≥15	Target Power [dBm]	24.5	19	16	1+2+3	Hotspot SAR	p≥15	Target Power [dBm]	24.5	19	16	1+2+3
		Back	0.967	0.342	0.056	1.365			Back	0.967	0.382	0.056	1.405
		Front	0.824	0.286	0.084	1.194			Front	0.824	0.349	0.084	1.257
		Top	-	-	0.023	0.023			Top	-	-	0.023	0.023
		Bottom	0.247	0.081	-	0.328			Bottom	0.247	0.096	-	0.343
		Right	0.600	-	-	0.600			Right	0.600	-	-	0.600
		Left	-	0.110	0.067	0.177			Left	-	0.181	0.067	0.248
	p<15	Target Power [dBm]	15	22.5	16	1+2+3	Hotspot SAR	p<15	Target Power [dBm]	15	23	16	1+2+3
		Back	0.098	0.644	0.056	0.798			Back	0.098	0.842	0.056	0.996
		Front	0.085	0.692	0.084	0.861			Front	0.085	0.872	0.084	1.041
		Top	-	-	0.023	0.023			Top	-	-	0.023	0.023
		Bottom	0.029	0.162	-	0.191			Bottom	0.029	0.235	-	0.264
		Right	0.072	-	-	0.072			Right	0.072	-	-	0.072
		Left	-	0.211	0.067	0.278			Left	-	0.371	0.067	0.438
Hotspot SAR	p≥10	Target Power [dBm]	23.5	15	16	1+2+3	Hotspot SAR	p≥10	Target Power [dBm]	23.5	15	16	1+2+3
		Back	0.519	0.148	0.056	0.723			Back	0.519	0.141	0.056	0.716
		Front	0.488	0.151	0.084	0.723			Front	0.488	0.127	0.084	0.699
		Top	-	-	0.023	0.023			Top	-	-	0.023	0.023
		Bottom	0.334	0.034	-	0.368			Bottom	0.334	0.034	-	0.368
		Right	0.352	-	-	0.352			Right	0.352	-	-	0.352
		Left	-	0.053	0.067	0.120			Left	-	0.064	0.067	0.131
	p<10	Target Power [dBm]	10	22.5	16	1+2+3	Hotspot SAR	p<10	Target Power [dBm]	10	23	16	1+2+3
		Back	0.015	0.644	0.056	0.715			Back	0.015	0.842	0.056	0.913
		Front	0.011	0.692	0.084	0.787			Front	0.011	0.872	0.084	0.967
		Top	-	-	0.023	0.023			Top	-	-	0.023	0.023
		Bottom	0.011	0.162	-	0.173			Bottom	0.011	0.235	-	0.246
		Right	0.004	-	-	0.004			Right	0.004	-	-	0.004
		Left	-	0.211	0.067	0.278			Left	-	0.371	0.067	0.438
Hotspot SAR	p≥10	Target Power [dBm]	23.5	15	16	1+2+3	Hotspot SAR	p≥10	Target Power [dBm]	23.5	15	16	1+2+3
		Back	0.747	0.148	0.056	0.951			Back	0.747	0.141	0.056	0.944
		Front	0.764	0.151	0.084	0.999			Front	0.764	0.127	0.084	0.975
		Top	-	-	0.023	0.023			Top	-	-	0.023	0.023
		Bottom	0.384	0.034	-	0.418			Bottom	0.384	0.034	-	0.418
		Right	0.377	-	-	0.377			Right	0.377	-	-	0.377
		Left	-	0.053	0.067	0.120			Left	-	0.064	0.067	0.131
	p<10	Target Power [dBm]	10	22.5	16	1+2+3	Hotspot SAR	p<10	Target Power [dBm]	10	23	16	1+2+3
		Back	0.025	0.644	0.056	0.725			Back	0.025	0.842	0.056	0.923
		Front	0.022	0.692	0.084	0.798			Front	0.022	0.872	0.084	0.978
		Top	-	-	0.023	0.023			Top	-	-	0.023	0.023
		Bottom	0.009	0.162	-	0.171			Bottom	0.009	0.235	-	0.244
		Right	0.007	-	-	0.007			Right	0.007	-	-	0.007
		Left	-	0.211	0.067	0.278			Left	-	0.371	0.067	0.438

Per FCC KDB Publication 941225 D06v01, the devices edges with antennas more than 2.5 cm from edge are not required to be evaluated for SAR (“-”).

### 13.9 Simultaneous Transmission Conclusion

The above numerical summed SAR results for all the worst-case simultaneous transmission conditions were below the SAR limit. Therefore, the above analysis is sufficient to determine that simultaneous transmission cases will not exceed the SAR limit and therefore no measured volumetric simultaneous SAR summation is required per FCC KDB Publication 447498 D01v05.

FCC ID: V65C6721A1	 PCTEST ENGINEERING LABORATORY, INC.	SAR EVALUATION REPORT	 KYOCERA	Reviewed by: Quality Manager
Document S/N: 0Y1212071742-R4.V65	Test Dates: 12/10/12 - 02/22/13	DUT Type: Portable Handset		Page 76 of 82

# 14 SAR MEASUREMENT VARIABILITY

## 14.1 Measurement Variability

Per FCC KDB Publication 865664 D01v01, SAR measurement variability was assessed for each frequency band, which was determined by the SAR probe calibration point and tissue-equivalent medium used for the device measurements. When both head and body tissue-equivalent media were required for SAR measurements in a frequency band, the variability measurement procedures were applied to the tissue medium with the highest measured SAR, using the highest measured SAR configuration for that tissue-equivalent medium. These additional measurements were repeated after the completion of all measurements requiring the same head or body tissue-equivalent medium in a frequency band. The test device was returned to ambient conditions (normal room temperature) with the battery fully charged before it was re-mounted on the device holder for the repeated measurement(s) to minimize any unexpected variations in the repeated results.

SAR Measurement Variability was assessed using the following procedures for each frequency band:

- 1) When the original highest measured SAR is  $\geq 0.80$  W/kg, the measurement was repeated once.
- 2) A second repeated measurement was performed only if the ratio of largest to smallest SAR for the original and first repeated measurements was  $> 1.20$  or when the original or repeated measurement was  $\geq 1.45$  W/kg (~ 10% from the 1-g SAR limit).
- 3) A third repeated measurement was performed only if the original, first or second repeated measurement was  $\geq 1.5$  W/kg and the ratio of largest to smallest SAR for the original, first and second repeated measurements is  $> 1.20$ .
- 4) Repeated measurements are not required when the original highest measured SAR is  $< 0.80$  W/kg

**Table 14-1  
Head SAR Measurement Variability Results**



HEAD VARIABILITY RESULTS														
Band	FREQUENCY		Mode/Band	Service	Side	Test Position	Data Rate (Mbps)	Measured SAR (1g)	1st Repeated SAR (1g)	Ratio	2nd Repeated SAR (1g)	Ratio	3rd Repeated SAR (1g)	Ratio
	MHz	Ch.						(W/kg)	(W/kg)		(W/kg)		(W/kg)	
1750	1750.00	20350	LTE Band 4 (AWS)	QPSK, 1 RB, 0 RB Offset	Left	Cheek	N/A	1.110	0.95	1.17	N/A	N/A	N/A	N/A
1900	1905.00	19150	LTE Band 2 (PCS)	QPSK, 1 RB, 0 RB Offset	Left	Cheek	N/A	1.120	1.06	1.06	N/A	N/A	N/A	N/A
ANSI / IEEE C95.1 1992 - SAFETY LIMIT Spatial Peak Uncontrolled Exposure/General Population						Head 1.6 W/kg (mW/g) averaged over 1 gram								

**Table 14-2  
Body SAR Measurement Variability Results**

BODY VARIABILITY RESULTS													
Band	FREQUENCY		Mode	Service	Side	Spacing	Measured SAR (1g)	1st Repeated SAR (1g)	Ratio	2nd Repeated SAR (1g)	Ratio	3rd Repeated SAR (1g)	Ratio
	MHz	Ch.					(W/kg)	(W/kg)		(W/kg)		(W/kg)	
835	836.52	384	Cell. CDMA	EVDO Rev. 0	back	10 mm	0.840	0.91	1.08	N/A	N/A	N/A	N/A
ANSI / IEEE C95.1 1992 - SAFETY LIMIT Spatial Peak Uncontrolled Exposure/General Population						Body 1.6 W/kg (mW/g) averaged over 1 gram							

## 14.2 Measurement Uncertainty

The measured SAR was  $< 1.5$  W/kg for all frequency bands. Therefore, per KDB Publication 865664 D01v01, the extended measurement uncertainty analysis per IEEE 1528-2003 was not required.



FCC ID: V65C6721A1	 PCTEST ENGINEERING LABORATORY, INC.	SAR EVALUATION REPORT	 KYOCERA	Reviewed by: Quality Manager
Document S/N: 0Y1212071742-R4.V65	Test Dates: 12/10/12 - 02/22/13	DUT Type: Portable Handset		Page 77 of 82

# 15 EQUIPMENT LIST

Manufacturer	Model	Description	Cal Date	Cal Interval	Cal Due	Serial Number
Agilent	85047A	S-Parameter Test Set	N/A	N/A	N/A	2904A00579
Agilent	85070E	Dielectric Probe Kit	2/14/2013	Annual	2/14/2014	MY44300633
Agilent	8594A	(9kHz-2.9GHz) Spectrum Analyzer	N/A	N/A	N/A	3051A00187
Agilent	8648D	(9kHz-4GHz) Signal Generator	10/10/2012	Annual	10/10/2013	3613A00315
Agilent	8648D	Signal Generator	4/3/2012	Annual	4/3/2013	3629U00687
Agilent	8753E	(30kHz-6GHz) Network Analyzer	4/4/2012	Annual	4/4/2013	JP38020182
Agilent	8753E	(30kHz-6GHz) Network Analyzer	4/3/2012	Annual	4/3/2013	US37390350
Agilent	E5515C	Wireless Communications Tester	4/4/2012	Annual	4/4/2013	US41140256
Agilent	E5515C	Wireless Communications Test Set	9/24/2012	Annual	9/24/2013	GB43163447
Agilent	E8257D	(250kHz-20GHz) Signal Generator	4/5/2012	Annual	4/5/2013	MY45470194
Amplifier Research	5S1G4	5W, 800MHz-4.2GHz		CBT	N/A	21910
Anritsu	MA24106A	USB Power Sensor	8/22/2012	Annual	8/22/2013	1231538
Anritsu	MA24106A	USB Power Sensor	8/22/2012	Annual	8/22/2013	1231535
Anritsu	MA2411B	Pulse Power Sensor	12/4/2012	Annual	12/4/2013	1207364
Anritsu	MA2411B	Pulse Power Sensor	12/5/2012	Annual	12/5/2013	1126066
Anritsu	MA2481D	Universal Sensor	12/17/2012	Annual	12/17/2013	1204419
Anritsu	MA2481D	Universal Sensor	12/17/2012	Annual	12/17/2013	1204343
Anritsu	ML2495A	Power Meter	10/11/2012	Annual	10/11/2013	1039008
Anritsu	ML2496A	Power Meter	11/28/2012	Annual	11/28/2013	1138001
Anritsu	MT8820C	Radio Communication Tester	11/6/2012	Annual	11/6/2013	6200901190
COMTECH	AR85729-5	Solid State Amplifier	CBT	N/A	CBT	M355A00-009
COMTECH	AR85729-5/5759B	Solid State Amplifier	CBT	N/A	CBT	M3W1A00-1002
Control Company	61220-416	Long-Stem Thermometer	7/1/2011	Biennial	7/1/2013	111642834
Intelligent Weigh	PD-3000	Electronic Balance	3/27/2012	Annual	3/27/2013	11081534
Intelligent Weighing	PD-3000	Electronic Balance	6/29/2012	Annual	6/29/2013	120405017
MCL	BW-N6W5+	6dB Attenuator	CBT	N/A	CBT	1139
MiniCircuits	SLP-2400+	Low Pass Filter	CBT	N/A	CBT	R8979500903
Mini-Circuits	BW-N20W5	Power Attenuator	CBT	N/A	CBT	1226
Mini-Circuits	BW-N20W5+	DC to 18 GHz Precision Fixed 20 dB Attenuator	CBT	N/A	CBT	N/A
Mini-Circuits	NLP-1200+	Low Pass Filter DC to 1000 MHz	CBT	N/A	CBT	N/A
Mini-Circuits	NLP-2950+	Low Pass Filter DC to 2700 MHz	CBT	N/A	CBT	N/A
Narda	4014C-6	4 - 8 GHz SMA 6 dB Directional Coupler	CBT	N/A	CBT	N/A
Narda	4772-3	Attenuator (3dB)	CBT	N/A	CBT	9406
Narda	BW-53W2	Attenuator (3dB)	CBT	N/A	CBT	120
Pasternack	PE2208-6	Bidirectional Coupler	CBT	N/A	CBT	N/A
Pasternack	PE2209-10	Bidirectional Coupler	CBT	N/A	CBT	N/A
Rohde & Schwarz	CMU200	Base Station Simulator	5/22/2012	Annual	5/22/2013	109892
Rohde & Schwarz	CMW500	LTE Radio Communication Tester	2/8/2013	Annual	2/8/2014	101699
Rohde & Schwarz	CMW500	LTE Radio Communication Tester	3/5/2012	Annual	3/5/2013	102060
Rohde & Schwarz	CMW500	LTE Radio Communication Tester	9/26/2012	Annual	9/26/2013	108798
Rohde & Schwarz	NRVD	Dual Channel Power Meter	10/12/2012	Biennial	10/12/2014	101695
Rohde & Schwarz	NRV-232	Peak Power Sensor	10/12/2012	Biennial	10/12/2014	836019/013
Rohde & Schwarz	SME06	Signal Generator	10/11/2012	Annual	10/11/2013	832026
Seekonk	NC-100	Torque Wrench (8" lb)	11/29/2011	Triennial	11/29/2014	21053
Seekonk	NC-100	Torque Wrench (8" lb)	3/5/2012	Triennial	3/5/2015	N/A
SPEAG	D1750V2	1750 MHz SAR Dipole	4/24/2012	Annual	4/24/2013	1051
SPEAG	D1900V2	1900 MHz SAR Dipole	2/22/2012	Annual	2/22/2013	5d149
SPEAG	D2450V2	2450 MHz SAR Dipole	8/23/2012	Annual	8/23/2013	719
SPEAG	D750V3	750 MHz Dipole	2/9/2012	Annual	2/9/2013	1054
SPEAG	D835V2	835 MHz SAR Dipole	8/23/2012	Annual	8/23/2013	4d026
SPEAG	D835V2	835 MHz SAR Dipole	4/20/2012	Annual	4/20/2013	4d119
SPEAG	D835V2	835 MHz SAR Dipole	2/3/2012	Annual	2/3/2013	4d132
SPEAG	DAE4	Dasy Data Acquisition Electronics	4/19/2012	Annual	4/19/2013	665
SPEAG	DAE4	Dasy Data Acquisition Electronics	1/18/2012	Annual	1/18/2013	1272
SPEAG	DAE4	Dasy Data Acquisition Electronics	9/19/2012	Annual	9/19/2013	1323
SPEAG	DAE4	Dasy Data Acquisition Electronics	11/13/2012	Annual	11/13/2013	1333
SPEAG	DAE4	Dasy Data Acquisition Electronics	8/24/2012	Annual	8/24/2013	1322
SPEAG	DAE4	Dasy Data Acquisition Electronics	5/7/2012	Annual	5/7/2013	1334
SPEAG	DAK-3.5	Dielectric Assessment Kit	6/19/2012	Annual	6/19/2013	1070
SPEAG	DAK-3.5	Dielectric Assessment Kit	12/11/2012	Annual	12/11/2013	1091
SPEAG	ES3DV2	SAR Probe	8/28/2012	Annual	8/28/2013	3022
SPEAG	ES3DV3	SAR Probe	4/24/2012	Annual	4/24/2013	3213
SPEAG	ES3DV3	SAR Probe	2/21/2012	Annual	2/21/2013	3258
SPEAG	ES3DV3	SAR Probe	5/18/2012	Annual	5/18/2013	3263
SPEAG	ES3DV3	SAR Probe	9/20/2012	Annual	9/20/2013	3288
SPEAG	ES3DV3	SAR Probe	11/15/2012	Annual	11/15/2013	3287
Tektronix	RSA-6114A	Real Time Spectrum Analyzer	4/5/2012	Annual	4/5/2013	8010177
VWR	23226-658	Long Stem Thermometer	3/30/2012	Biennial	3/30/2014	12219874
VWR	36934-158	Wall-Mounted Thermometer	9/30/2011	Biennial	9/30/2013	111859323
VWR	62344-925	Mini-Thermometer	10/24/2011	Biennial	10/24/2013	111886430

Note: CBT (Calibrated Before Testing). Prior to testing, the measurement paths containing a cable, amplifier, attenuator, coupler or filter were connected to a calibrated source (i.e. a signal generator) to determine the losses of the measurement path. The power meter offset was then adjusted to compensate for the measurement system losses. This level offset is stored within the power meter before measurements are made. This calibration verification procedure applies to the system verification and output power measurements. The calibrated reading is then taken directly from the power meter after compensation of the losses for all final power measurements.



- All equipment was used within its calibration date:
  - SAR DAE unit 1272 was used solely for testing before its calibration due date of 1/18/2013
  - SAR Probe unit 3258 was used solely for testing before its calibration due date of 2/21/2013
  - 750 MHz SAR Dipole unit 1054 was used solely for testing before its calibration due date of 2/09/2013
  - 835 MHz SAR Dipole unit 4d132 was used solely for testing before its calibration due date of 2/03/2013
  - 1900 MHz SAR Dipole unit 5d149 was used solely for testing before its calibration due date of 2/22/2013

FCC ID: V65C6721A1		SAR EVALUATION REPORT		Reviewed by: Quality Manager
Document S/N: OY1212071742-R4.V65	Test Dates: 12/10/12 - 02/22/13	DUT Type: Portable Handset		Page 78 of 82

# 16 MEASUREMENT UNCERTAINTIES

a	b	c	d	e= f(d,k)	f	g	h = c x f/e	i = c x g/e	k	
Uncertainty Component	IEEE 1528 Sec.	Tol. (± %)	Prob. Dist.	Div.	c <sub>i</sub> 1gm	c <sub>i</sub> 10 gms	1gm u <sub>i</sub> (± %)	10gms u <sub>i</sub> (± %)	v <sub>i</sub>	
<b>Measurement System</b>										
Probe Calibration	E.2.1	6.0	N	1	1.0	1.0	6.0	6.0	∞	
Axial Isotropy	E.2.2	0.25	N	1	0.7	0.7	0.2	0.2	∞	
Hemishperical Isotropy	E.2.2	1.3	N	1	1.0	1.0	1.3	1.3	∞	
Boundary Effect	E.2.3	0.4	N	1	1.0	1.0	0.4	0.4	∞	
Linearity	E.2.4	0.3	N	1	1.0	1.0	0.3	0.3	∞	
System Detection Limits	E.2.5	5.1	N	1	1.0	1.0	5.1	5.1	∞	
Readout Electronics	E.2.6	1.0	N	1	1.0	1.0	1.0	1.0	∞	
Response Time	E.2.7	0.8	R	1.73	1.0	1.0	0.5	0.5	∞	
Integration Time	E.2.8	2.6	R	1.73	1.0	1.0	1.5	1.5	∞	
RF Ambient Conditions	E.6.1	3.0	R	1.73	1.0	1.0	1.7	1.7	∞	
Probe Positioner Mechanical Tolerance	E.6.2	0.4	R	1.73	1.0	1.0	0.2	0.2	∞	
Probe Positioning w/ respect to Phantom	E.6.3	2.9	R	1.73	1.0	1.0	1.7	1.7	∞	
Extrapolation, Interpolation & Integration algorithms for Max. SAR Evaluation	E.5	1.0	R	1.73	1.0	1.0	0.6	0.6	∞	
<b>Test Sample Related</b>										
Test Sample Positioning	E.4.2	6.0	N	1	1.0	1.0	6.0	6.0	287	
Device Holder Uncertainty	E.4.1	3.32	R	1.73	1.0	1.0	1.9	1.9	∞	
Output Power Variation - SAR drift measurement	6.6.2	5.0	R	1.73	1.0	1.0	2.9	2.9	∞	
<b>Phantom &amp; Tissue Parameters</b>										
Phantom Uncertainty (Shape & Thickness tolerances)	E.3.1	4.0	R	1.73	1.0	1.0	2.3	2.3	∞	
Liquid Conductivity - deviation from target values	E.3.2	5.0	R	1.73	0.64	0.43	1.8	1.2	∞	
Liquid Conductivity - measurement uncertainty	E.3.3	3.8	N	1	0.64	0.43	2.4	1.6	6	
Liquid Permittivity - deviation from target values	E.3.2	5.0	R	1.73	0.60	0.49	1.7	1.4	∞	
Liquid Permittivity - measurement uncertainty	E.3.3	4.5	N	1	0.60	0.49	2.7	2.2	6	
<b>Combined Standard Uncertainty (k=1)</b>							RSS	12.1	11.7	299
<b>Expanded Uncertainty</b> (95% CONFIDENCE LEVEL)							k=2	24.2	23.5	

The above measurement uncertainties are according to IEEE Std. 1528-2003



FCC ID: V65C6721A1	 <b>PCTEST</b> ENGINEERING LABORATORY, INC.	<b>SAR EVALUATION REPORT</b>	 <b>KYOCERA</b>	Reviewed by: Quality Manager
Document S/N: 0Y1212071742-R4.V65	Test Dates: 12/10/12 - 02/22/13	DUT Type: Portable Handset		Page 79 of 82

## 17 CONCLUSION

### 17.1 Measurement Conclusion

The SAR evaluation indicates that the EUT complies with the RF radiation exposure limits of the FCC and Industry Canada, with respect to all parameters subject to this test. These measurements were taken to simulate the RF effects of RF exposure under worst-case conditions. Precise laboratory measures were taken to assure repeatability of the tests. The results and statements relate only to the item(s) tested.



Please note that the absorption and distribution of electromagnetic energy in the body are very complex phenomena that depend on the mass, shape, and size of the body, the orientation of the body with respect to the field vectors, and the electrical properties of both the body and the environment. Other variables that may play a substantial role in possible biological effects are those that characterize the environment (e.g. ambient temperature, air velocity, relative humidity, and body insulation) and those that characterize the individual (e.g. age, gender, activity level, debilitation, or disease). Because various factors may interact with one another to vary the specific biological outcome of an exposure to electromagnetic fields, any protection guide should consider maximal amplification of biological effects as a result of field-body interactions, environmental conditions, and physiological variables. [3]

FCC ID: V65C6721A1	 <b>PCTEST</b> ENGINEERING LABORATORY, INC.	SAR EVALUATION REPORT	 <b>KYOCERA</b>	Reviewed by: Quality Manager
Document S/N: 0Y1212071742-R4.V65	Test Dates: 12/10/12 - 02/22/13	DUT Type: Portable Handset		Page 80 of 82





## 18 REFERENCES

- [1] Federal Communications Commission, ET Docket 93-62, Guidelines for Evaluating the Environmental Effects of Radiofrequency Radiation, Aug. 1996.
- [2] ANSI/IEEE C95.1-2005, American National Standard safety levels with respect to human exposure to radio frequency electromagnetic fields, 3kHz to 300GHz, New York: IEEE, 2006.
- [3] ANSI/IEEE C95.1-1992, American National Standard safety levels with respect to human exposure to radio frequency electromagnetic fields, 3kHz to 300GHz, New York: IEEE, Sept. 1992.
- [4] ANSI/IEEE C95.3-2002, IEEE Recommended Practice for the Measurement of Potentially Hazardous Electromagnetic Fields - RF and Microwave, New York: IEEE, December 2002.
- [5] Federal Communications Commission, OET Bulletin 65 (Edition 97-01), Supplement C (Edition 01-01), Evaluating Compliance with FCC Guidelines for Human Exposure to Radiofrequency Electromagnetic Fields, June 2001.
- [6] IEEE Standards Coordinating Committee 34 – IEEE Std. 1528-2003, Recommended Practice for Determining the Peak Spatial-Average Specific Absorption Rate (SAR) in the Human Body Due to Wireless Communications Devices.
- [7] NCRP, National Council on Radiation Protection and Measurements, Biological Effects and Exposure Criteria for RadioFrequency Electromagnetic Fields, NCRP Report No. 86, 1986. Reprinted Feb. 1995.
- [8] T. Schmid, O. Egger, N. Kuster, Automated E-field scanning system for dosimetric assessments, IEEE Transaction on Microwave Theory and Techniques, vol. 44, Jan. 1996, pp. 105-113.
- [9] K. Pokovic, T. Schmid, N. Kuster, Robust setup for precise calibration of E-field probes in tissue simulating liquids at mobile communications frequencies, ICECOM97, Oct. 1997, pp. -124.
- [10] K. Pokovic, T. Schmid, and N. Kuster, E-field Probe with improved isotropy in brain simulating liquids, Proceedings of the ELMAR, Zadar, Croatia, June 23-25, 1996, pp. 172-175.
- [11] Schmid & Partner Engineering AG, Application Note: Data Storage and Evaluation, June 1998, p2.
- [12] V. Hombach, K. Meier, M. Burkhardt, E. Kuhn, N. Kuster, The Dependence of EM Energy Absorption upon Human Modeling at 900 MHz, IEEE Transaction on Microwave Theory and Techniques, vol. 44 no. 10, Oct. 1996, pp. 1865-1873.
- [13] N. Kuster and Q. Balzano, Energy absorption mechanism by biological bodies in the near field of dipole antennas above 300MHz, IEEE Transaction on Vehicular Technology, vol. 41, no. 1, Feb. 1992, pp. 17-23.
- [14] G. Hartsgrrove, A. Kraszewski, A. Surowiec, Simulated Biological Materials for Electromagnetic Radiation Absorption Studies, University of Ottawa, Bioelectromagnetics, Canada: 1987, pp. 29-36.
- [15] Q. Balzano, O. Garay, T. Manning Jr., Electromagnetic Energy Exposure of Simulated Users of Portable Cellular Telephones, IEEE Transactions on Vehicular Technology, vol. 44, no.3, Aug. 1995.
- [16] W. Gander, Computermathematik, Birkhaeuser, Basel, 1992.
- [17] W.H. Press, S.A. Teukolsky, W.T. Vetterling, and B.P. Flannery, Numerical Recipes in C, The Art of Scientific Computing, Second edition, Cambridge University Press, 1992.

FCC ID: V65C6721A1	 <b>PCTEST</b> ENGINEERING LABORATORY, INC.	<b>SAR EVALUATION REPORT</b>	 <b>KYOCERA</b>	Reviewed by: Quality Manager
Document S/N: 0Y1212071742-R4.V65	Test Dates: 12/10/12 - 02/22/13	DUT Type: Portable Handset		Page 81 of 82

- [18] Federal Communications Commission, OET Bulletin 65, Evaluating Compliance with FCC Guidelines for Human Exposure to Radiofrequency Electromagnetic Fields. Supplement C, Dec. 1997.
- [19] N. Kuster, R. Kastle, T. Schmid, Dosimetric evaluation of mobile communications equipment with known precision, IEEE Transaction on Communications, vol. E80-B, no. 5, May 1997, pp. 645-652.
- [20] CENELEC CLC/SC111B, European Prestandard (prENV 50166-2), Human Exposure to Electromagnetic Fields High-frequency: 10kHz-300GHz, Jan. 1995.
- [21] Prof. Dr. Niels Kuster, ETH, Eidgenössische Technische Hochschule Zürich, Dosimetric Evaluation of the Cellular Phone.
- [22] IEC 62209-1, Human exposure to radio frequency fields from hand-held and body-mounted wireless communication devices - Human models, instrumentation, and procedures - Part 1: Procedure to determine the specific absorption rate (SAR) for hand-held devices used in close proximity to the ear (frequency range of 300 MHz to 3 GHz), Feb. 2005.
- [23] Industry Canada RSS-102 Radio Frequency Exposure Compliance of Radiocommunication Apparatus (All Frequency Bands) Issue 4, March 2010.
- [24] Health Canada Safety Code 6 Limits of Human Exposure to Radio Frequency Electromagnetic Fields in the Frequency Range from 3 kHz – 300 GHz, 2009
- [25] FCC Public Notice DA-02-1438. Office of Engineering and Technology Announces a Transition Period for the Phantom Requirements of Supplement C to OET Bulletin 65, June 19, 2002
- [26] FCC SAR Test Procedures for 2G-3G Devices, Mobile Hotspot and UMPC Devices KDB Publications 941225, D01-D07
- [27] SAR Measurement procedures for IEEE 802.11a/b/g KDB Publication 248227 D01v01r02
- [28] FCC SAR Considerations for Handsets with Multiple Transmitters and Antennas, KDB Publications 648474 D02-D04
- [29] FCC SAR Evaluation Considerations for Laptop, Notebook, Netbook and Tablet Computers, FCC KDB Publication 616217 D04
- [30] FCC SAR Measurement and Reporting Requirements for 100MHz – 6 GHz, KDB Publications 865664 D01-D02
- [31] FCC General RF Exposure Guidance and SAR Procedures for Dongles, KDB Publication 447498, D01-D02
- [32] Anexo à Resolução No. 533, de 10 de Setembro de 2009.
- [33] IEC 62209-2, Human exposure to radio frequency fields from hand-held and body-mounted wireless communication devices - Human models, instrumentation, and procedures - Part 2: Procedure to determine the specific absorption rate (SAR) for wireless communication devices used in close proximity to the human body (frequency range of 30 MHz to 6 GHz), Mar. 2010.

FCC ID: V65C6721A1	 <b>SAR EVALUATION REPORT</b>			Reviewed by: Quality Manager
Document S/N: 0Y1212071742-R4.V65	Test Dates: 12/10/12 - 02/22/13	DUT Type: Portable Handset		Page 82 of 82

## APPENDIX A: SAR TEST DATA

# PCTEST ENGINEERING LABORATORY, INC.

**DUT: V65C6721A1; Type: Portable Handset; Serial: SAR CDMA - BC0**

Communication System: Cellular CDMA; Frequency: 836.52 MHz; Duty Cycle: 1:1

Medium: 835 Head Medium parameters used (interpolated):

$f = 836.52 \text{ MHz}$ ;  $\sigma = 0.914 \text{ S/m}$ ;  $\epsilon_r = 40.914$ ;  $\rho = 1000 \text{ kg/m}^3$

Phantom section: Right Section

Test Date: 02-11-2013; Ambient Temp: 24.4°C; Tissue Temp: 23.4°C

Probe: ES3DV2 - SN3022; ConvF(6.03, 6.03, 6.03); Calibrated: 8/28/2012;

Sensor-Surface: 4mm (Mechanical Surface Detection)

Electronics: DAE4 Sn1322; Calibrated: 8/24/2012

Phantom: SAM Main; Type: SAM 4.0; Serial: TP-1406

Measurement SW: DASY4, Version 4.7 (80); SEMCAD X Version 14.6.8 (7028)

**Mode: Cellular CDMA, Right Head, Cheek, Mid.ch**

**Area Scan (7x14x1):** Measurement grid: dx=15mm, dy=15mm

**Zoom Scan (5x5x7)/Cube 0:** Measurement grid: dx=8mm, dy=8mm, dz=5mm

Reference Value = 29.816 V/m; Power Drift = 0.01 dB

Peak SAR (extrapolated) = 0.907 W/kg

**SAR(1 g) = 0.694 W/kg; SAR(10 g) = 0.509 W/kg**

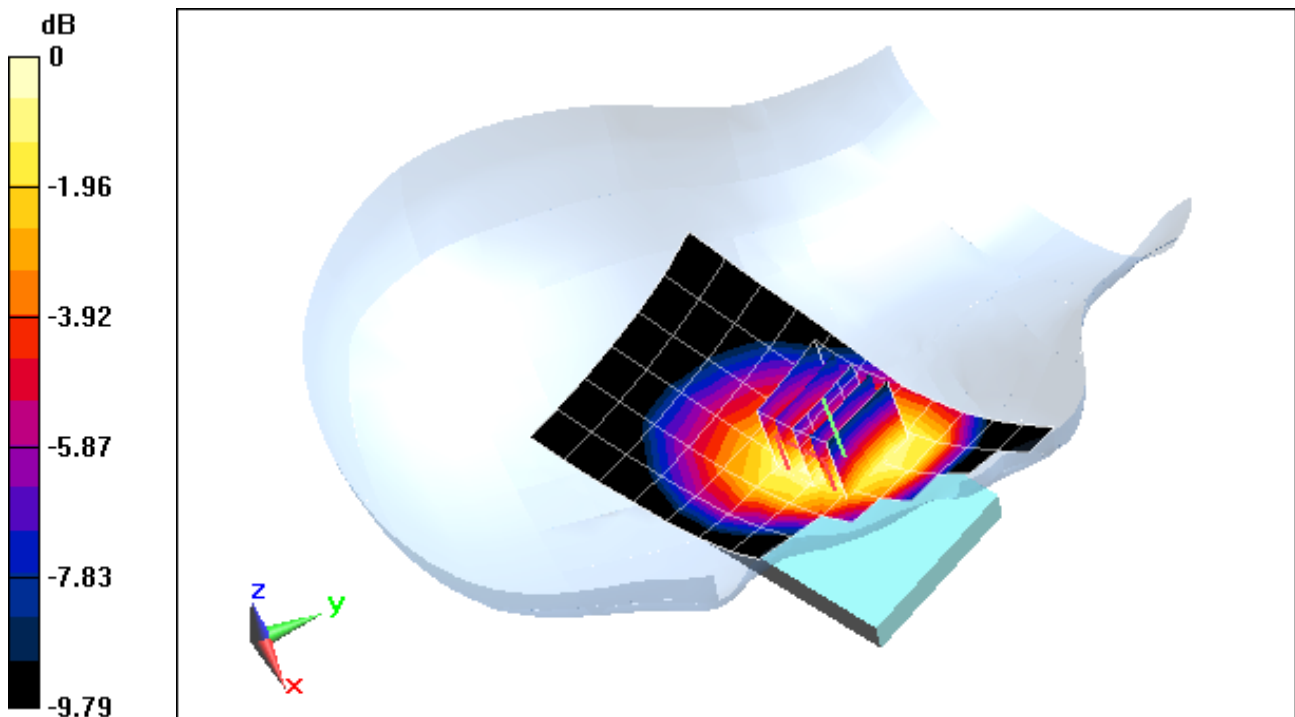

0 dB = 0.739 W/kg = -1.31 dBW/kg

# PCTEST ENGINEERING LABORATORY, INC.

**DUT: V65C6721A1; Type: Portable Handset; Serial: SAR CDMA - BC15**

Communication System: AWS CDMA; Frequency: 1732.5 MHz; Duty Cycle: 1:1

Medium: 1750 Head Medium parameters used (interpolated):

$f = 1732.5 \text{ MHz}$ ;  $\sigma = 1.35 \text{ S/m}$ ;  $\epsilon_r = 39.926$ ;  $\rho = 1000 \text{ kg/m}^3$

Phantom section: Right Section

Test Date: 02-07-2013; Ambient Temp: 23.4°C; Tissue Temp: 21.4°C

Probe: ES3DV3 - SN3288; ConvF(5.51, 5.51, 5.51); Calibrated: 9/20/2012;

Sensor-Surface: 4mm (Mechanical Surface Detection)

Electronics: DAE4 Sn1323; Calibrated: 9/19/2012

Phantom: SAM v5.0 front; Type: QD000P40CD; Serial: TP-1646

Measurement SW: DASY52, Version 52.8 (5); SEMCAD X Version 14.6.8 (7028)

**Mode: AWS CDMA, Right Head, Cheek, Mid.ch**

**Area Scan (8x14x1):** Measurement grid: dx=15mm, dy=15mm

**Zoom Scan (5x5x7)/Cube 0:** Measurement grid: dx=8mm, dy=8mm, dz=5mm

Reference Value = 24.786 V/m; Power Drift = 0.00 dB

Peak SAR (extrapolated) = 1.04 W/kg

**SAR(1 g) = 0.685 W/kg**

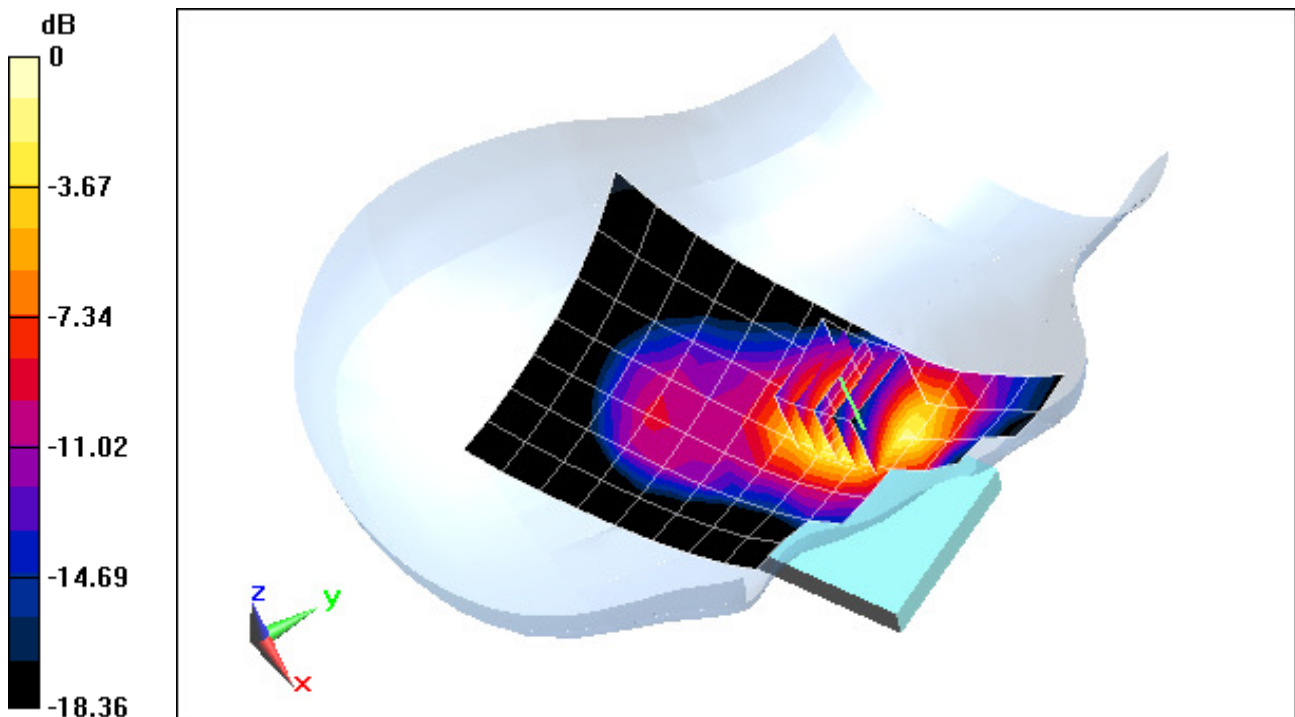

0 dB = 0.748 W/kg = -1.26 dBW/kg

# PCTEST ENGINEERING LABORATORY, INC.

**DUT: V65C6721A1; Type: Portable Handset; Serial: SAR CDMA - BC1**

Communication System: CDMA; Frequency: 1880 MHz; Duty Cycle: 1:1

Medium: 1900 Head Medium parameters used:

$$f = 1880 \text{ MHz}; \sigma = 1.424 \text{ S/m}; \epsilon_r = 39.21; \rho = 1000 \text{ kg/m}^3$$

Phantom section: Right Section

Test Date: 02-08-2013; Ambient Temp: 24.3°C; Tissue Temp: 21.9°C

Probe: ES3DV3 - SN3263; ConvF(5.09, 5.09, 5.09); Calibrated: 5/18/2012;

Sensor-Surface: 4mm (Mechanical Surface Detection)

Electronics: DAE4 Sn1334; Calibrated: 5/7/2012

Phantom: SAM V5.0 Right; Type: QD000P40CD; Serial: 1647

Measurement SW: DASY52, Version 52.8 (5); SEMCAD X Version 14.6.8 (7028)

**Mode: PCS CDMA, Right Head, Cheek, Mid.ch**

**Area Scan (8x14x1):** Measurement grid: dx=15mm, dy=15mm

**Zoom Scan (5x5x7)/Cube 0:** Measurement grid: dx=8mm, dy=8mm, dz=5mm

Reference Value = 26.462 V/m; Power Drift = -0.02 dB

Peak SAR (extrapolated) = 1.40 W/kg

**SAR(1 g) = 0.880 W/kg**

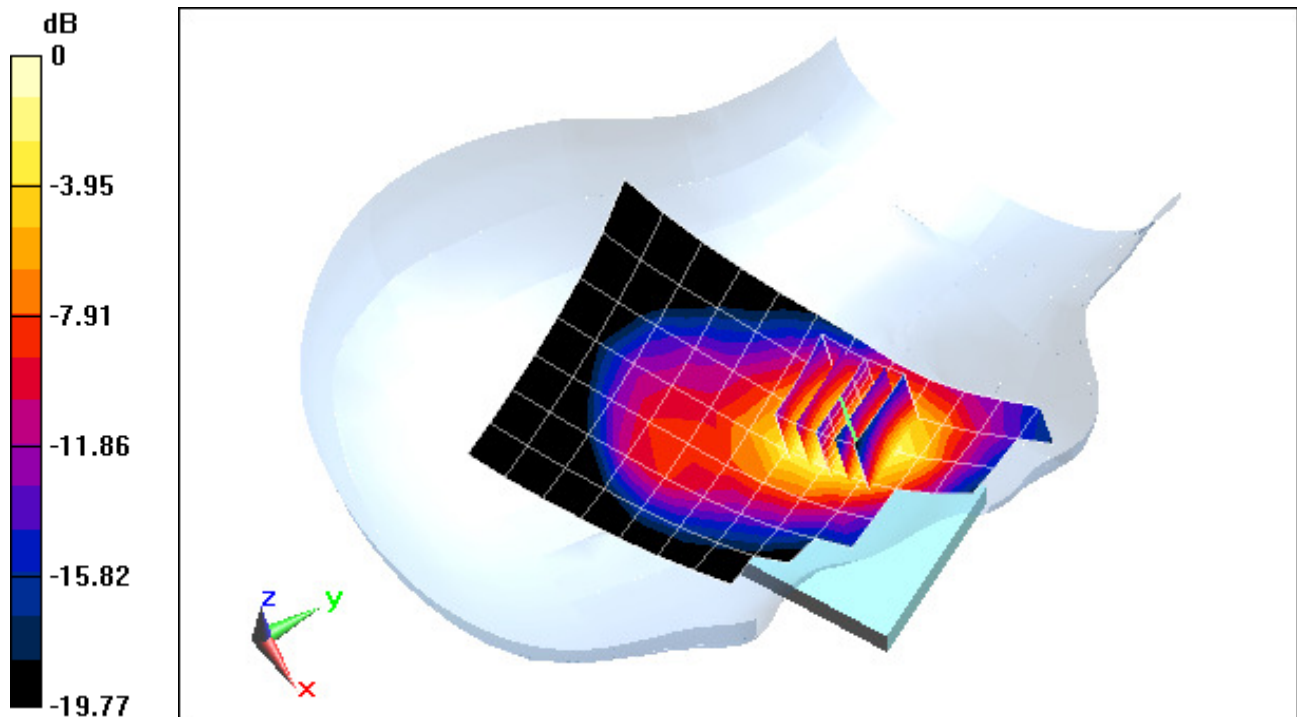

0 dB = 0.954 W/kg = -0.20 dBW/kg

# PCTEST ENGINEERING LABORATORY, INC.

**DUT: V65C6721A1; Type: Portable Handset; Serial: LTE SAR/HAC**

Communication System: LTE Band 12; Frequency: 707.5 MHz; Duty Cycle: 1:1

Medium: 750 Head Medium parameters used (interpolated):

$f = 707.5 \text{ MHz}$ ;  $\sigma = 0.875 \text{ S/m}$ ;  $\epsilon_r = 42.39$ ;  $\rho = 1000 \text{ kg/m}^3$

Phantom section: Left Section

Test Date: 12-20-2012; Ambient Temp: 23.3°C; Tissue Temp: 22.2°C

Probe: ES3DV3 - SN3288; ConvF(6.67, 6.67, 6.67); Calibrated: 9/20/2012;

Sensor-Surface: 4mm (Mechanical Surface Detection)

Electronics: DAE4 Sn1323; Calibrated: 9/19/2012

Phantom: SAM v5.0 Left; Type: QD000P40CD; Serial: TP: 1687

Measurement SW: DASY52, Version 52.8 (3); SEMCAD X Version 14.6.8 (7028)

**Mode: LTE Band 12, Left Head, Cheek, Mid.ch**  
**QPSK, 10 MHz Bandwidth, 1 RB, 0 RB Offset**

**Area Scan (8x12x1):** Measurement grid: dx=15mm, dy=15mm

**Zoom Scan (5x5x7)/Cube 0:** Measurement grid: dx=8mm, dy=8mm, dz=5mm

Reference Value = 22.138 V/m; Power Drift = 0.04 dB

Peak SAR (extrapolated) = 0.530 W/kg

**SAR(1 g) = 0.364 W/kg; SAR(10 g) = 0.249 W/kg**

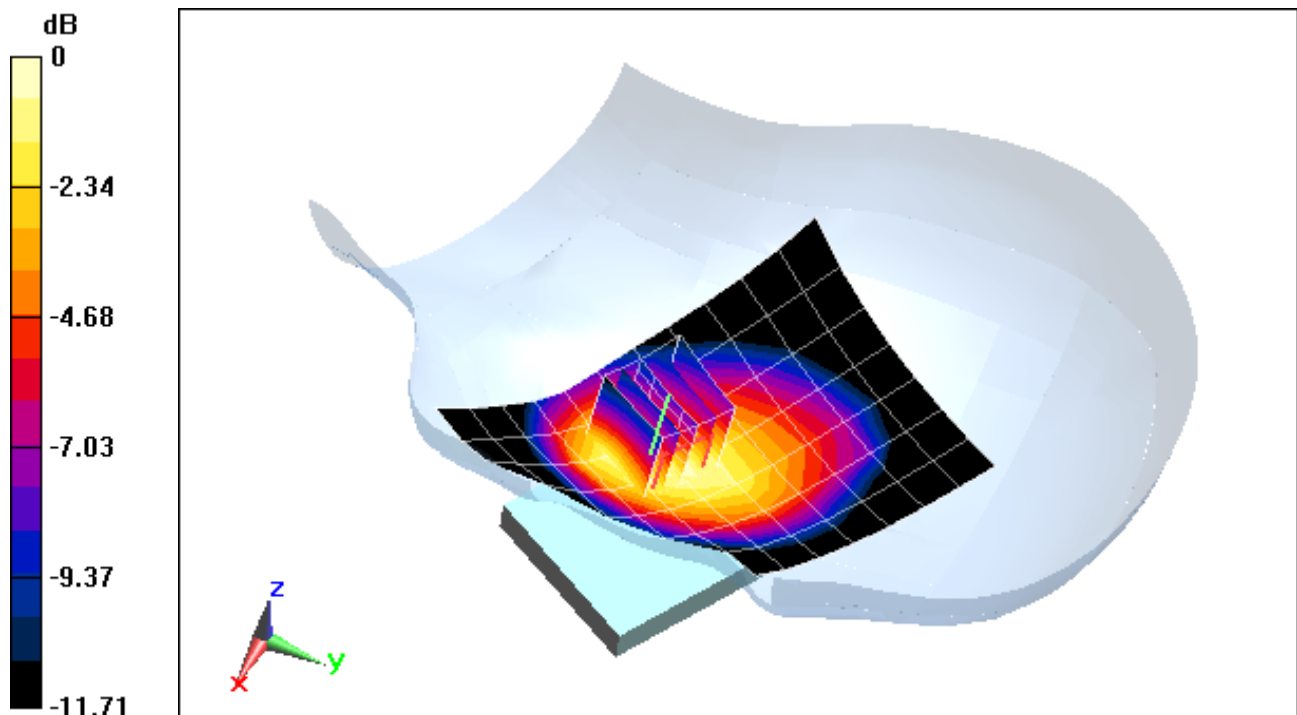

0 dB = 0.389 W/kg = -4.10 dBW/kg

# PCTEST ENGINEERING LABORATORY, INC.

**DUT: V65C6721A1; Type: Portable Handset; Serial: LTE SAR/HAC**

Communication System: LTE Band 17; Frequency: 710 MHz; Duty Cycle: 1:1

Medium: 750 Head Medium parameters used:

$f = 710 \text{ MHz}$ ;  $\sigma = 0.88 \text{ S/m}$ ;  $\epsilon_r = 42.37$ ;  $\rho = 1000 \text{ kg/m}^3$

Phantom section: Left Section

Test Date: 12-20-2012; Ambient Temp: 23.3°C; Tissue Temp: 22.2°C

Probe: ES3DV3 - SN3288; ConvF(6.67, 6.67, 6.67); Calibrated: 9/20/2012;

Sensor-Surface: 4mm (Mechanical Surface Detection)

Electronics: DAE4 Sn1323; Calibrated: 9/19/2012

Phantom: SAM v5.0 Left; Type: QD000P40CD; Serial: TP: 1687

Measurement SW: DASY52, Version 52.8 (3); SEMCAD X Version 14.6.8 (7028)

**Mode: LTE Band 17, Left Head, Cheek, Mid.ch,  
QPSK, 10 MHz Bandwidth, 1 RB, 0 RB Offset**

**Area Scan (8x12x1):** Measurement grid: dx=15mm, dy=15mm

**Zoom Scan (5x5x7)/Cube 0:** Measurement grid: dx=8mm, dy=8mm, dz=5mm

Reference Value = 23.505 V/m; Power Drift = 0.12 dB

Peak SAR (extrapolated) = 0.613 W/kg

**SAR(1 g) = 0.419 W/kg; SAR(10 g) = 0.283 W/kg**

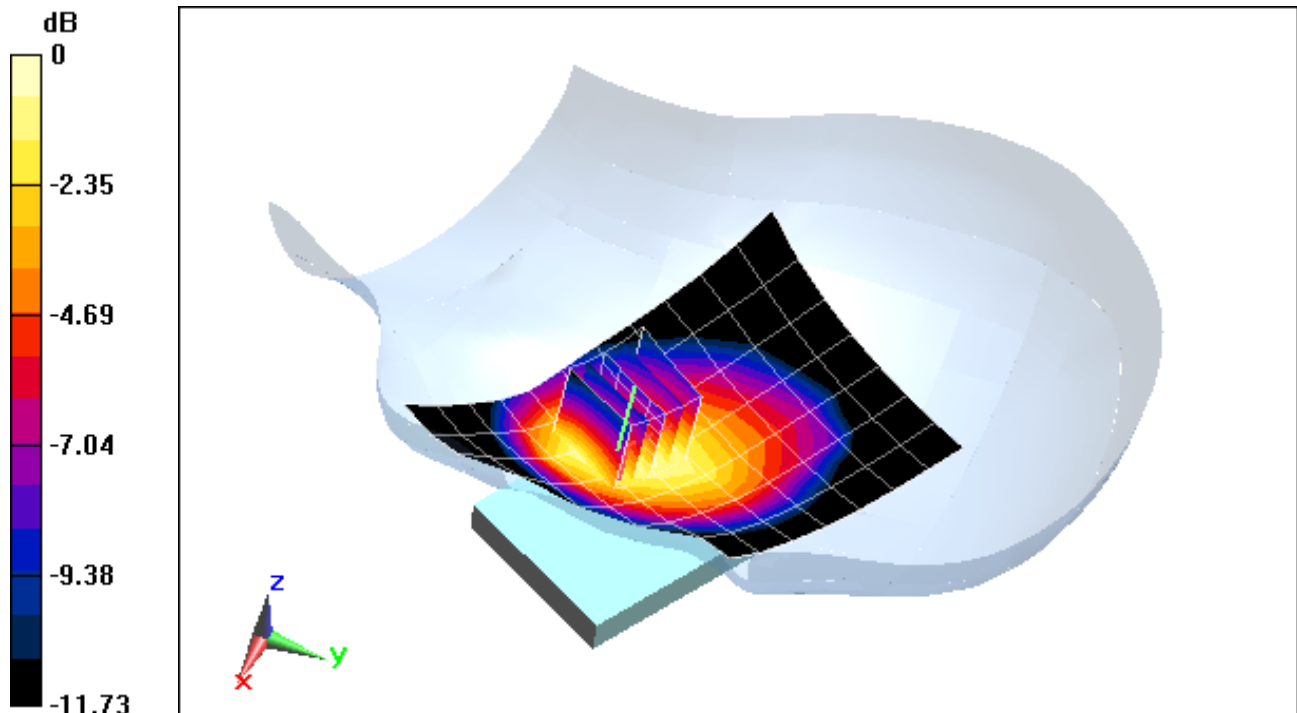

0 dB = 0.446 W/kg = -3.51 dBW/kg



# PCTEST ENGINEERING LABORATORY, INC.

**DUT: V65C6721A1; Type: Portable Handset; Serial: LTE SAR/HAC**

Communication System: LTE Band 5 (Cell.); Frequency: 836.5 MHz; Duty Cycle: 1:1

Medium: 835 Head Medium parameters used (interpolated):

$f = 836.5 \text{ MHz}$ ;  $\sigma = 0.882 \text{ S/m}$ ;  $\epsilon_r = 40.704$ ;  $\rho = 1000 \text{ kg/m}^3$

Phantom section: Left Section

Test Date: 12-17-2012; Ambient Temp: 21.3°C; Tissue Temp: 20.6°C

Probe: ES3DV3 - SN3288; ConvF(6.41, 6.41, 6.41); Calibrated: 9/20/2012;

Sensor-Surface: 4mm (Mechanical Surface Detection)

Electronics: DAE4 Sn1323; Calibrated: 9/19/2012

Phantom: SAM v5.0 front; Type: QD000P40CD; Serial: TP-1646

Measurement SW: DASY52, Version 52.8 (5); SEMCAD X Version 14.6.8 (7028)

**Mode: LTE Band 5 (Cell.), Left Head, Cheek, Mid.ch**  
**QPSK, 10 MHz Bandwidth, 1 RB, 49 RB Offset**

**Area Scan (8x12x1):** Measurement grid: dx=15mm, dy=15mm

**Zoom Scan (5x5x7)/Cube 0:** Measurement grid: dx=8mm, dy=8mm, dz=5mm

Reference Value = 25.139 V/m; Power Drift = -0.02 dB

Peak SAR (extrapolated) = 0.671 W/kg

**SAR(1 g) = 0.469 W/kg; SAR(10 g) = 0.314 W/kg**

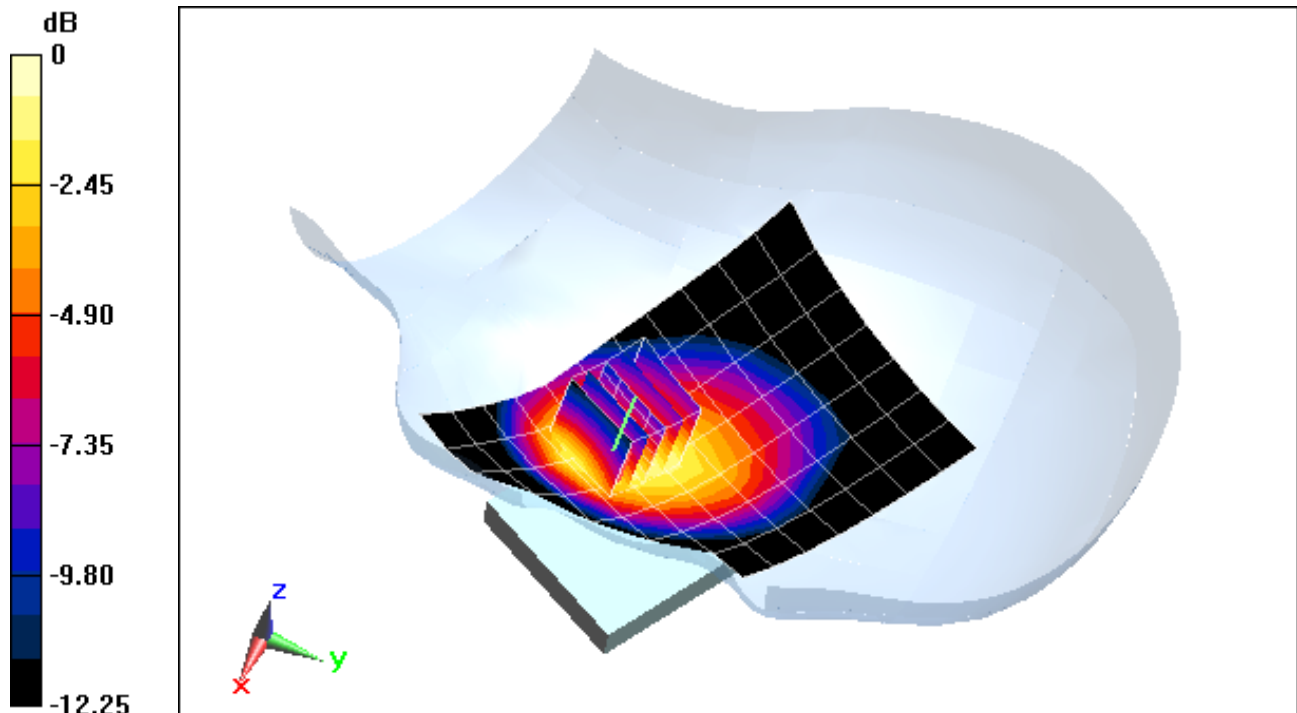

0 dB = 0.497 W/kg = -3.04 dBW/kg

# PCTEST ENGINEERING LABORATORY, INC.

**DUT: V65C6721A1; Type: Portable Handset; Serial: SAR LTE - Band4**

Communication System: LTE Band 4 (AWS); Frequency: 1750 MHz; Duty Cycle: 1:1

Medium: 1750 Head Medium parameters used:

$$f = 1750 \text{ MHz}; \sigma = 1.368 \text{ S/m}; \epsilon_r = 39.83; \rho = 1000 \text{ kg/m}^3$$

Phantom section: Left Section

Test Date: 02-07-2013; Ambient Temp: 23.4°C; Tissue Temp: 21.4°C

Probe: ES3DV3 - SN3288; ConvF(5.51, 5.51, 5.51); Calibrated: 9/20/2012;

Sensor-Surface: 4mm (Mechanical Surface Detection)

Electronics: DAE4 Sn1323; Calibrated: 9/19/2012

Phantom: SAM v5.0 front; Type: QD000P40CD; Serial: TP-1646

Measurement SW: DASY52, Version 52.8 (5); SEMCAD X Version 14.6.8 (7028)

**Mode: LTE Band 4 (AWS), Left Head, Cheek, High.ch**  
**QPSK, 10 MHz Bandwidth, 1 RB, 0 RB Offset**

**Area Scan (7x14x1):** Measurement grid: dx=15mm, dy=15mm

**Zoom Scan (5x5x7)/Cube 0:** Measurement grid: dx=8mm, dy=8mm, dz=5mm

Reference Value = 32.143 V/m; Power Drift = 0.02 dB

Peak SAR (extrapolated) = 1.74 W/kg

**SAR(1 g) = 1.11 W/kg; SAR(10 g) = 0.651 W/kg**

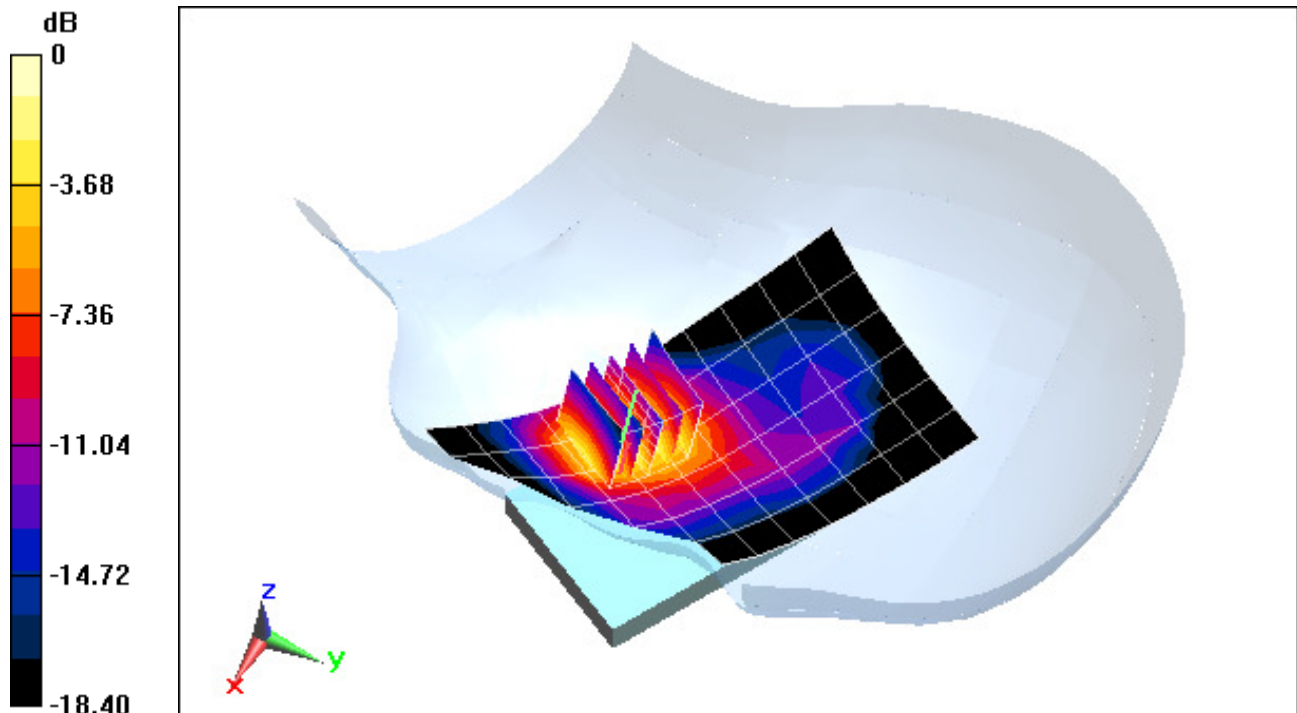

0 dB = 1.23 W/kg = 0.90 dBW/kg

# PCTEST ENGINEERING LABORATORY, INC.

**DUT: V65C6721A1; Type: Portable Handset; Serial: SAR LTE - Band2**

Communication System: LTE Band 2 (PCS); Frequency: 1905 MHz; Duty Cycle: 1:1

Medium: 1900 Head Medium parameters used (interpolated):

$f = 1905 \text{ MHz}$ ;  $\sigma = 1.456 \text{ S/m}$ ;  $\epsilon_r = 39.118$ ;  $\rho = 1000 \text{ kg/m}^3$

Phantom section: Left Section

Test Date: 02-08-2013; Ambient Temp: 22.8°C; Tissue Temp: 21.3°C

Probe: ES3DV3 - SN3213; ConvF(5.02, 5.02, 5.02); Calibrated: 4/24/2012;

Sensor-Surface: 4mm (Mechanical Surface Detection)

Electronics: DAE4 Sn665; Calibrated: 4/19/2012

Phantom: SAM Right; Type: QD000P40CD; Serial: 1686

Measurement SW: DASY52, Version 52.8 (5); SEMCAD X Version 14.6.8 (7028)

**Mode: LTE Band 2 (PCS), Left Head, Cheek, High.ch**

**QPSK, 10 MHz Bandwidth, 1 RB, 0 RB Offset**

**Area Scan (7x14x1):** Measurement grid: dx=15mm, dy=15mm

**Zoom Scan (5x5x7)/Cube 0:** Measurement grid: dx=8mm, dy=8mm, dz=5mm

Reference Value = 31.001 V/m; Power Drift = -0.02 dB

Peak SAR (extrapolated) = 1.75 W/kg

**SAR(1 g) = 1.12 W/kg; SAR(10 g) = 0.663 W/kg**

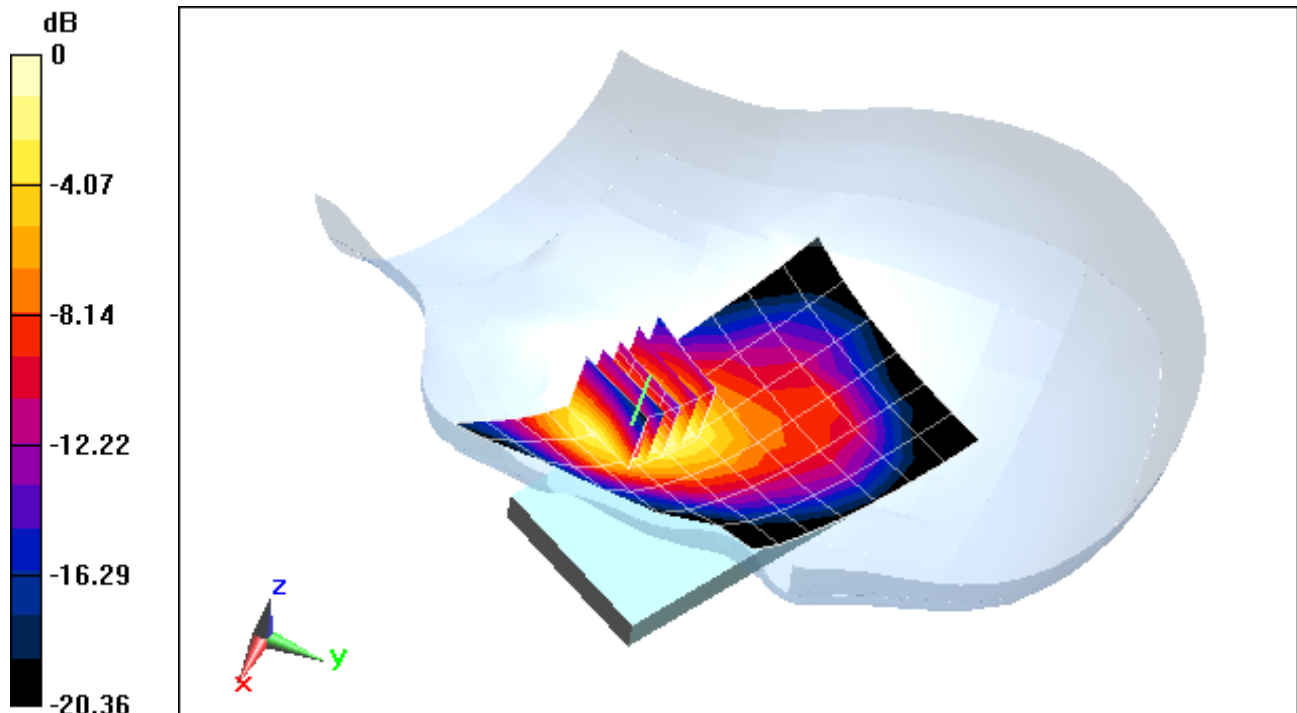

0 dB = 1.23 W/kg = 0.90 dBW/kg

# PCTEST ENGINEERING LABORATORY, INC.

**DUT: V65C6721A1; Type: Portable Handset; Serial: WIFI/BT RADIATION**

Communication System: IEEE 802.11b; Frequency: 2437 MHz; Duty Cycle: 1:1

Medium: 2450 Head Medium parameters used (interpolated):

$$f = 2437 \text{ MHz}; \sigma = 1.834 \text{ S/m}; \epsilon_r = 38.36; \rho = 1000 \text{ kg/m}^3$$

Phantom section: Right Section

Test Date: 12-18-2012; Ambient Temp: 23.3°C; Tissue Temp: 21.4°C

Probe: ES3DV3 - SN3258; ConvF(4.46, 4.46, 4.46); Calibrated: 2/21/2012;

Sensor-Surface: 3mm (Mechanical Surface Detection)

Electronics: DAE4 Sn1272; Calibrated: 1/18/2012

Phantom: SAM Main; Type: SAM 4.0; Serial: TP-1114

Measurement SW: DASY4, Version 4.7 (80); SEMCAD X Version 14.6.8 (7028)

**Mode: IEEE 802.11b, Right Head, Cheek, Ch 06, 1 Mbps**

**Area Scan (10x17x1):** Measurement grid: dx=12mm, dy=12mm

**Zoom Scan (7x7x7)/Cube 0:** Measurement grid: dx=5mm, dy=5mm, dz=5mm

Reference Value = 13.617 V/m; Power Drift = 0.02 dB

Peak SAR (extrapolated) = 0.617 W/kg

**SAR(1 g) = 0.295 W/kg; SAR(10 g) = 0.144 W/kg**

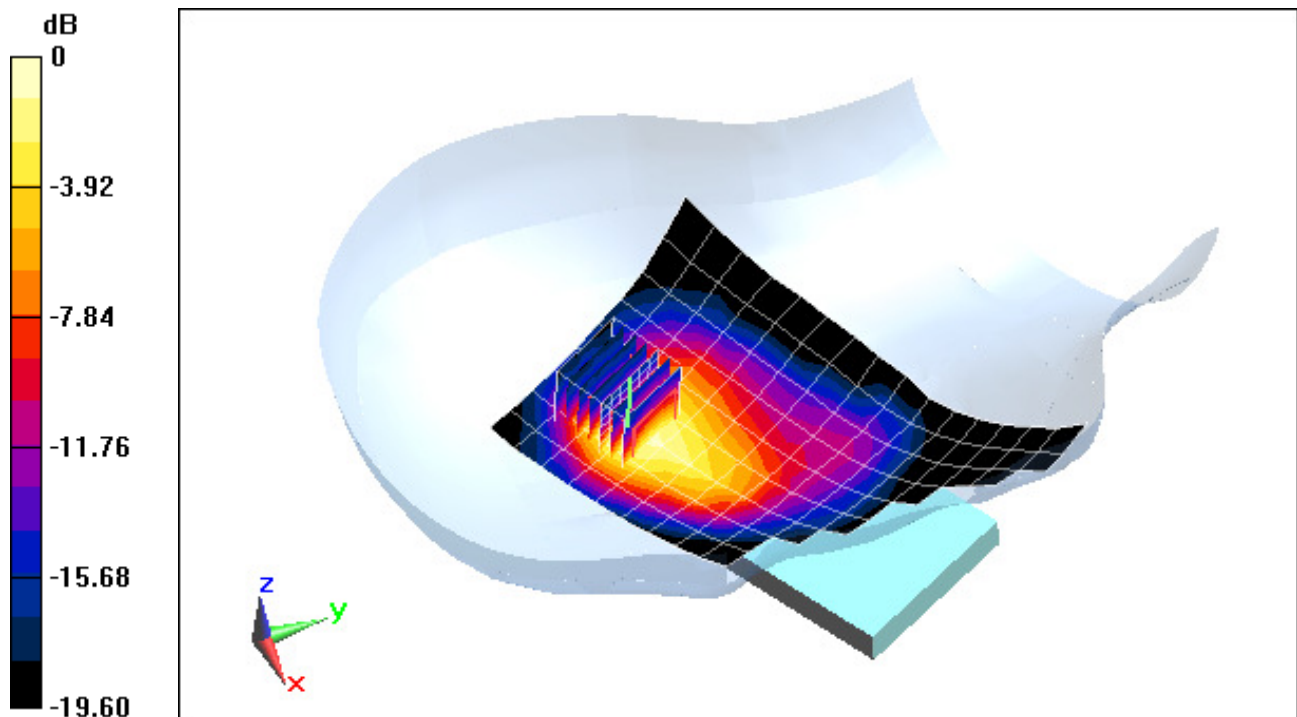

0 dB = 0.375 W/kg = -4.26 dBW/kg

# PCTEST ENGINEERING LABORATORY, INC.

**DUT: V65C6721A1; Type: Portable Handset; Serial: SAR CDMA - BC0**

Communication System: CDMA; Frequency: 824.7 MHz; Duty Cycle: 1:1

Medium: 835 Body Medium parameters used (interpolated):

$f = 824.7 \text{ MHz}$ ;  $\sigma = 0.989 \text{ S/m}$ ;  $\epsilon_r = 54.66$ ;  $\rho = 1000 \text{ kg/m}^3$

Phantom section: Flat Section; Space: 1.0 cm

Test Date: 12-10-2012; Ambient Temp: 21.9°C; Tissue Temp: 20.2°C

Probe: ES3DV3 - SN3263; ConvF(6.15, 6.15, 6.15); Calibrated: 5/18/2012;

Sensor-Surface: 4mm (Mechanical Surface Detection)

Electronics: DAE4 Sn1334; Calibrated: 5/7/2012

Phantom: SAM 5.0 front; Type: QD000P40CD; Serial: TP:-1648

Measurement SW: DASY52, Version 52.8 (3); SEMCAD X Version 14.6.8 (7028)

**Mode: Cell. CDMA, Body SAR, Back side, Low.ch**

**Area Scan (7x12x1):** Measurement grid: dx=15mm, dy=15mm

**Zoom Scan (5x5x7)/Cube 0:** Measurement grid: dx=8mm, dy=8mm, dz=5mm

Reference Value = 30.137 V/m; Power Drift = -0.07 dB

Peak SAR (extrapolated) = 1.04 W/kg

**SAR(1 g) = 0.831 W/kg**

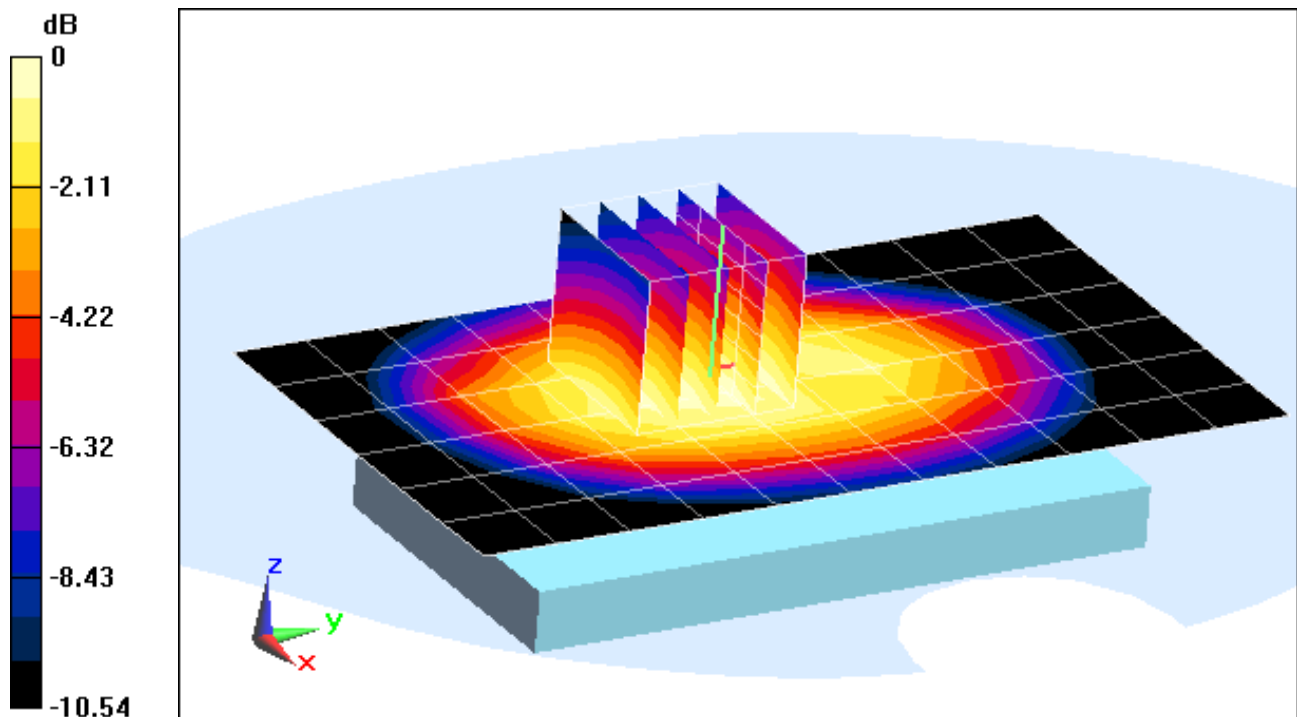

0 dB = 0.870 W/kg = -0.60 dBW/kg

# PCTEST ENGINEERING LABORATORY, INC.

**DUT: V65C6721A1 ; Type: Portable Handset; Serial: SAR CDMA - BC0**

Communication System: Cellular CDMA; Frequency: 836.52 MHz; Duty Cycle: 1:1

Medium: 835 Body Medium parameters used (interpolated):

$f = 836.52 \text{ MHz}$ ;  $\sigma = 1.006 \text{ S/m}$ ;  $\epsilon_r = 53.046$ ;  $\rho = 1000 \text{ kg/m}^3$

Phantom section: Flat Section; Space: 1.0 cm

Test Date: 02-19-2013; Ambient Temp: 22.8°C; Tissue Temp: 22.2°C

Probe: ES3DV3 - SN3287; ConvF(6.06, 6.06, 6.06); Calibrated: 11/15/2012;

Sensor-Surface: 4mm (Mechanical Surface Detection)

Electronics: DAE4 Sn1333; Calibrated: 11/13/2012

Phantom: SAM with CRP; Type: SAM 4.0; Serial: TP1375

Measurement SW: DASY4, Version 4.7 (80); SEMCAD X Version 14.6.8 (7028)

**Mode: Cellular EVDO, Body SAR, Back side, Mid.ch**

**Area Scan (7x12x1):** Measurement grid: dx=15mm, dy=15mm

**Zoom Scan (5x5x7)/Cube 0:** Measurement grid: dx=8mm, dy=8mm, dz=5mm

Reference Value = 32.205 V/m; Power Drift = 0.04 dB

Peak SAR (extrapolated) = 1.13 W/kg

**SAR(1 g) = 0.906 W/kg; SAR(10 g) = 0.676 W/kg**

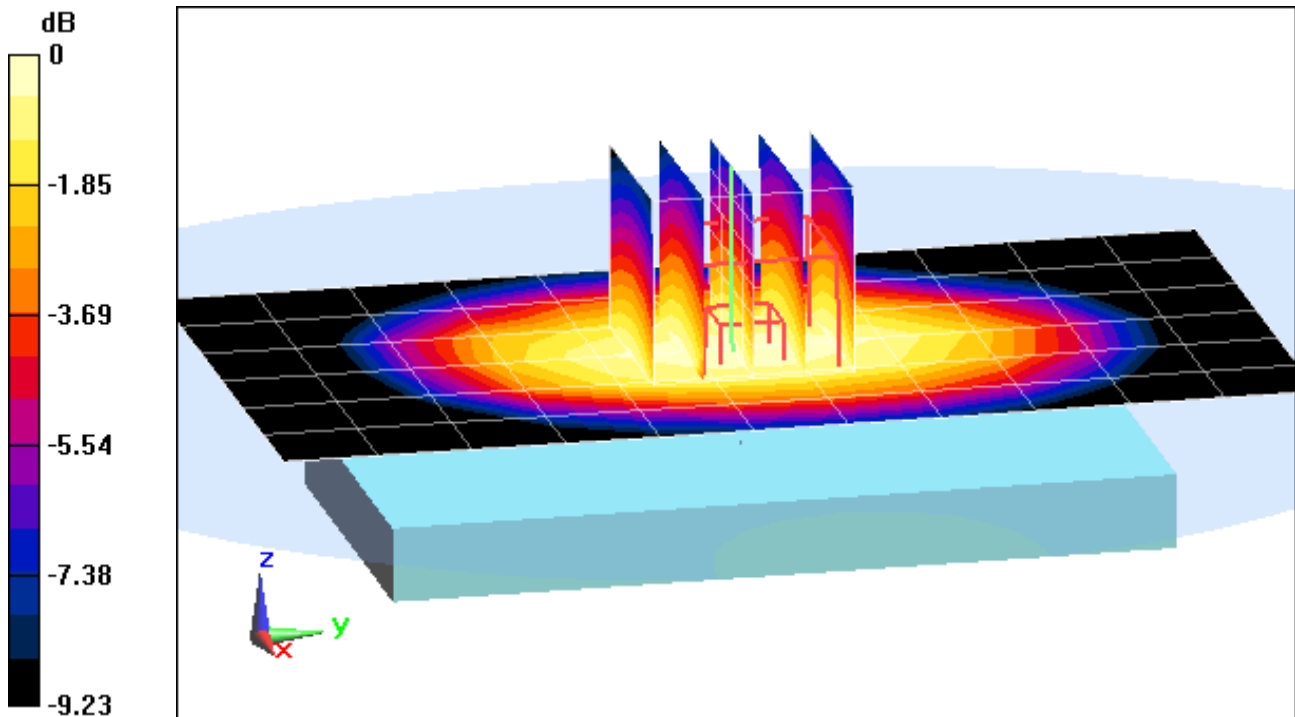

0 dB = 0.953 W/kg = -0.21 dBW/kg

# PCTEST ENGINEERING LABORATORY, INC.

**DUT: V65C6721A1; Type: Portable Handset; Serial: SAR CDMA - BC15**

Communication System: CDMA; Frequency: 1732.5 MHz; Duty Cycle: 1:1

Medium: 1750 Body Medium parameters used (interpolated):

$f = 1732.5 \text{ MHz}$ ;  $\sigma = 1.444 \text{ S/m}$ ;  $\epsilon_r = 52.383$ ;  $\rho = 1000 \text{ kg/m}^3$

Phantom section: Flat Section; Space: 1.0 cm

Test Date: 02-10-2013; Ambient Temp: 23.3°C; Tissue Temp: 22.3°C

Probe: ES3DV3 - SN3288; ConvF(5.18, 5.18, 5.18); Calibrated: 9/20/2012;

Sensor-Surface: 4mm (Mechanical Surface Detection)

Electronics: DAE4 Sn1323; Calibrated: 9/19/2012

Phantom: SAM v5.0 Left; Type: QD000P40CD; Serial: TP: 1687

Measurement SW: DASY52, Version 52.8 (5); SEMCAD X Version 14.6.8 (7028)

**Mode: AWS CDMA, Body SAR, Back side, Mid.ch**

**Area Scan (7x12x1):** Measurement grid: dx=15mm, dy=15mm

**Zoom Scan (5x5x7)/Cube 0:** Measurement grid: dx=8mm, dy=8mm, dz=5mm

Reference Value = 18.146 V/m; Power Drift = 0.03 dB

Peak SAR (extrapolated) = 0.754 W/kg

**SAR(1 g) = 0.469 W/kg**

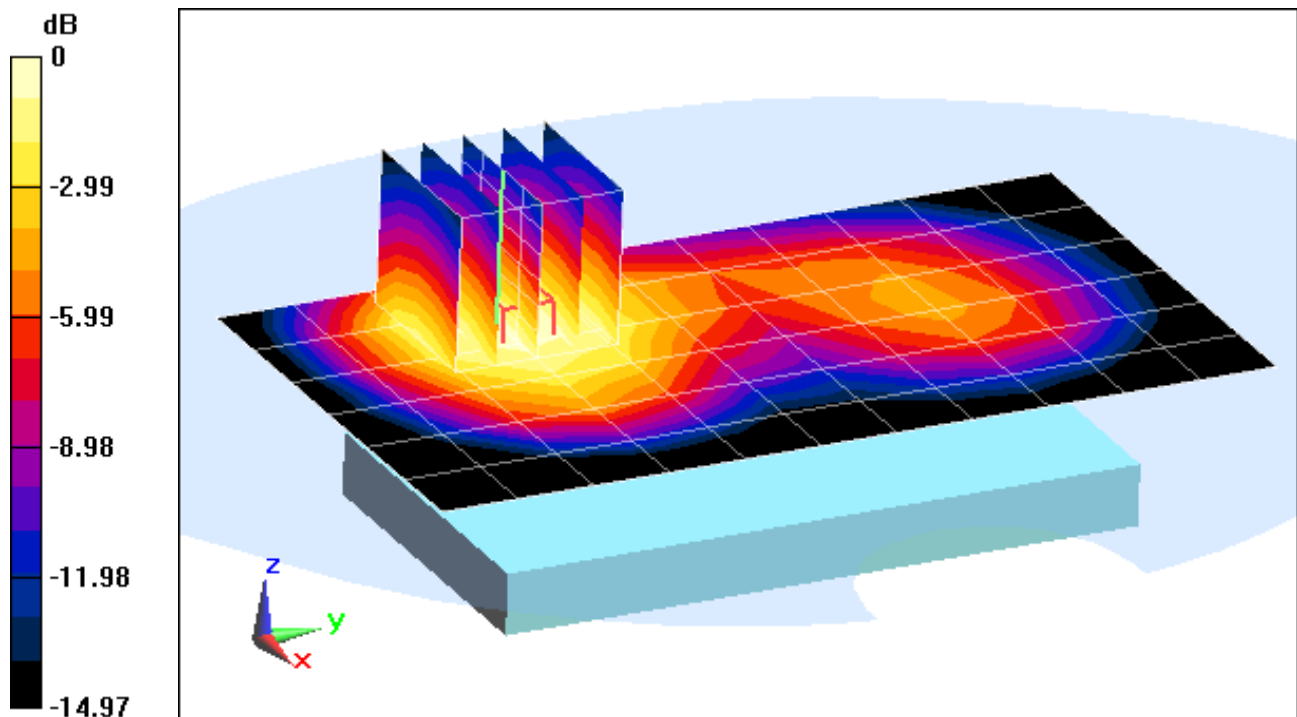

0 dB = 0.509 W/kg = -2.93 dBW/kg



# PCTEST ENGINEERING LABORATORY, INC.

**DUT: V65C6721A1; Type: Portable Handset; Serial: SAR CDMA - BC1**

Communication System: CDMA; Frequency: 1880 MHz; Duty Cycle: 1:1

Medium: 1900 Body Medium parameters used:

$f = 1880 \text{ MHz}$ ;  $\sigma = 1.532 \text{ S/m}$ ;  $\epsilon_r = 52.88$ ;  $\rho = 1000 \text{ kg/m}^3$

Phantom section: Flat Section; Space: 1.0 cm

Test Date: 02-07-2013; Ambient Temp: 23.4°C; Tissue Temp: 22.1°C

Probe: ES3DV3 - SN3263; ConvF(4.76, 4.76, 4.76); Calibrated: 5/18/2012;

Sensor-Surface: 4mm (Mechanical Surface Detection)

Electronics: DAE4 Sn1334; Calibrated: 5/7/2012

Phantom: SAM 5.0 front; Type: QD000P40CD; Serial: TP:-1648

Measurement SW: DASY52, Version 52.8 (5); SEMCAD X Version 14.6.8 (7028)

**Mode: PCS CDMA, Body SAR, Back side, Mid.ch**

**Area Scan (7x12x1):** Measurement grid: dx=15mm, dy=15mm

**Zoom Scan (5x5x7)/Cube 0:** Measurement grid: dx=8mm, dy=8mm, dz=5mm

Reference Value = 21.624 V/m; Power Drift = 0.02 dB

Peak SAR (extrapolated) = 1.05 W/kg

**SAR(1 g) = 0.655 W/kg**

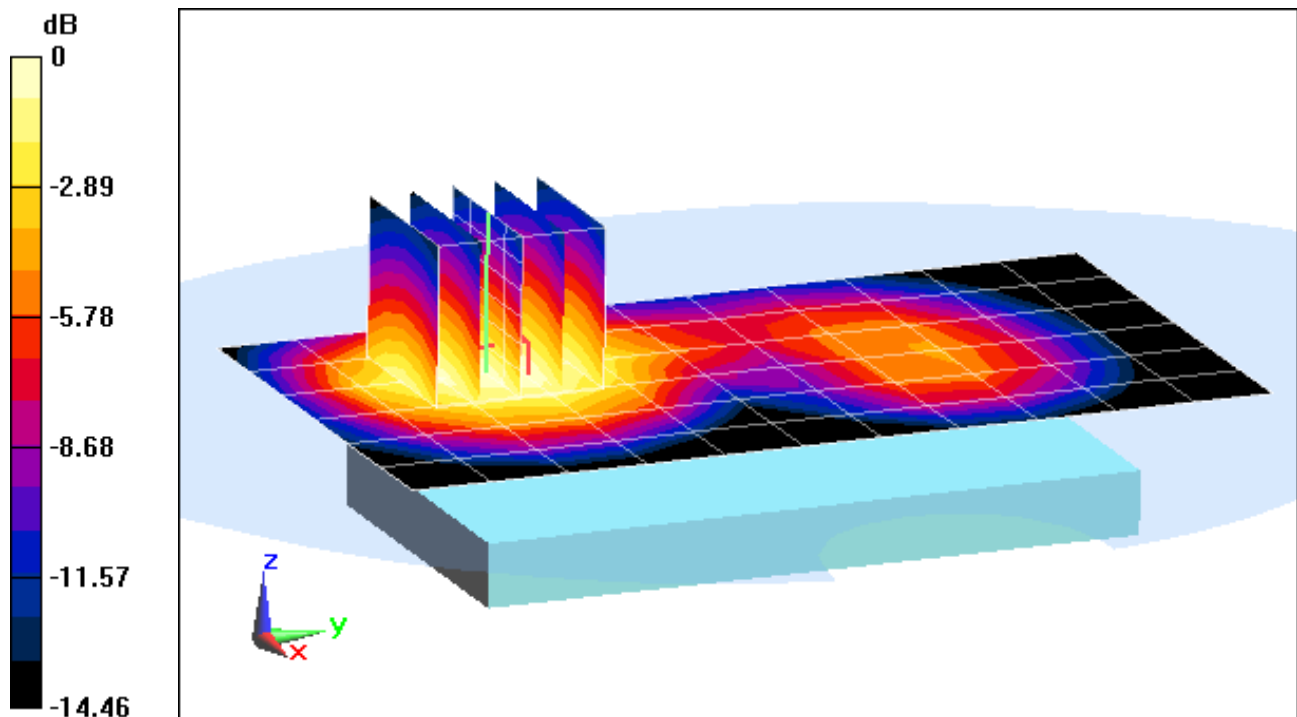

0 dB = 0.695 W/kg = -1.58 dBW/kg



# PCTEST ENGINEERING LABORATORY, INC.

**DUT: V65C6721A1; Type: Portable Handset; Serial: SAR CDMA - BC1**

Communication System: CDMA; Frequency: 1880 MHz; Duty Cycle: 1:1

Medium: 1900 Body Medium parameters used:

$f = 1880 \text{ MHz}$ ;  $\sigma = 1.532 \text{ S/m}$ ;  $\epsilon_r = 52.88$ ;  $\rho = 1000 \text{ kg/m}^3$

Phantom section: Flat Section; Space: 1.0 cm

Test Date: 02-07-2013; Ambient Temp: 23.4°C; Tissue Temp: 22.1°C

Probe: ES3DV3 - SN3263; ConvF(4.76, 4.76, 4.76); Calibrated: 5/18/2012;

Sensor-Surface: 4mm (Mechanical Surface Detection)

Electronics: DAE4 Sn1334; Calibrated: 5/7/2012

Phantom: SAM 5.0 front; Type: QD000P40CD; Serial: TP:-1648

Measurement SW: DASY52, Version 52.8 (5); SEMCAD X Version 14.6.8 (7028)

**Mode: PCS CDMA, Body SAR, Front side, Mid.ch**

**Area Scan (7x12x1):** Measurement grid: dx=15mm, dy=15mm

**Zoom Scan (5x5x7)/Cube 0:** Measurement grid: dx=8mm, dy=8mm, dz=5mm

Reference Value = 22.079 V/m; Power Drift = -0.08 dB

Peak SAR (extrapolated) = 1.05 W/kg

**SAR(1 g) = 0.670 W/kg**

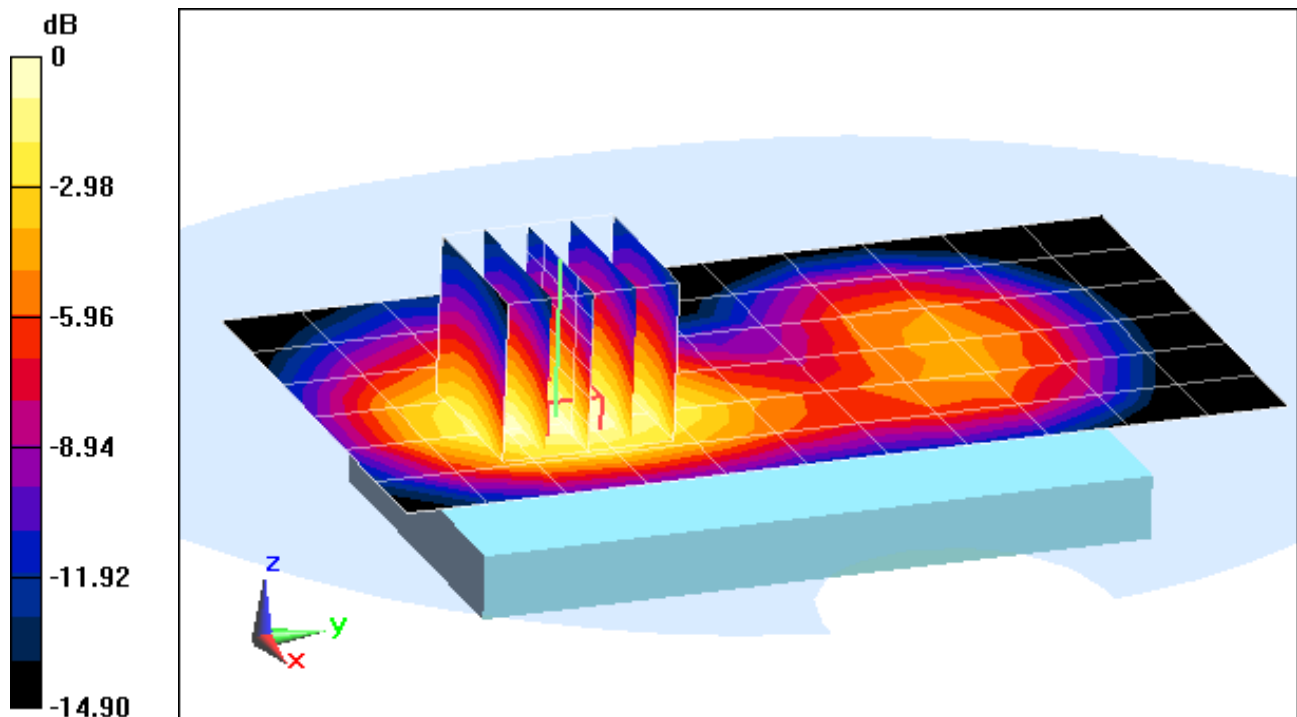

0 dB = 0.718 W/kg = -1.44 dBW/kg

# PCTEST ENGINEERING LABORATORY, INC.

**DUT: V65C6721A1; Type: Portable Handset; Serial: LTE SAR/HAC**

Communication System: LTE Band 12; Frequency: 707.5 MHz; Duty Cycle: 1:1

Medium: 750 Body Medium parameters used (interpolated):

$f = 707.5 \text{ MHz}$ ;  $\sigma = 0.92 \text{ S/m}$ ;  $\epsilon_r = 57.128$ ;  $\rho = 1000 \text{ kg/m}^3$

Phantom section: Flat Section; Space: 1.0 cm

Test Date: 12-14-2012; Ambient Temp: 22.4°C; Tissue Temp: 22.2°C

Probe: ES3DV3 - SN3263; ConvF(6.26, 6.26, 6.26); Calibrated: 5/18/2012;

Sensor-Surface: 4mm (Mechanical Surface Detection)

Electronics: DAE4 Sn1334; Calibrated: 5/7/2012

Phantom: SAM 5.0 front; Type: QD000P40CD; Serial: TP:-1648

Measurement SW: DASY52, Version 52.8 (3); SEMCAD X Version 14.6.8 (7028)

**Mode: LTE Band 12, Body SAR, Back side, Mid.ch**  
**QPSK, 10 MHz Bandwidth, 1 RB, 0 RB Offset**

**Area Scan (10x17x1):** Measurement grid: dx=10mm, dy=10mm

**Zoom Scan (5x5x7)/Cube 0:** Measurement grid: dx=8mm, dy=8mm, dz=5mm

Reference Value = 19.651 V/m; Power Drift = 0.01 dB

Peak SAR (extrapolated) = 0.529 W/kg

**SAR(1 g) = 0.326 W/kg**

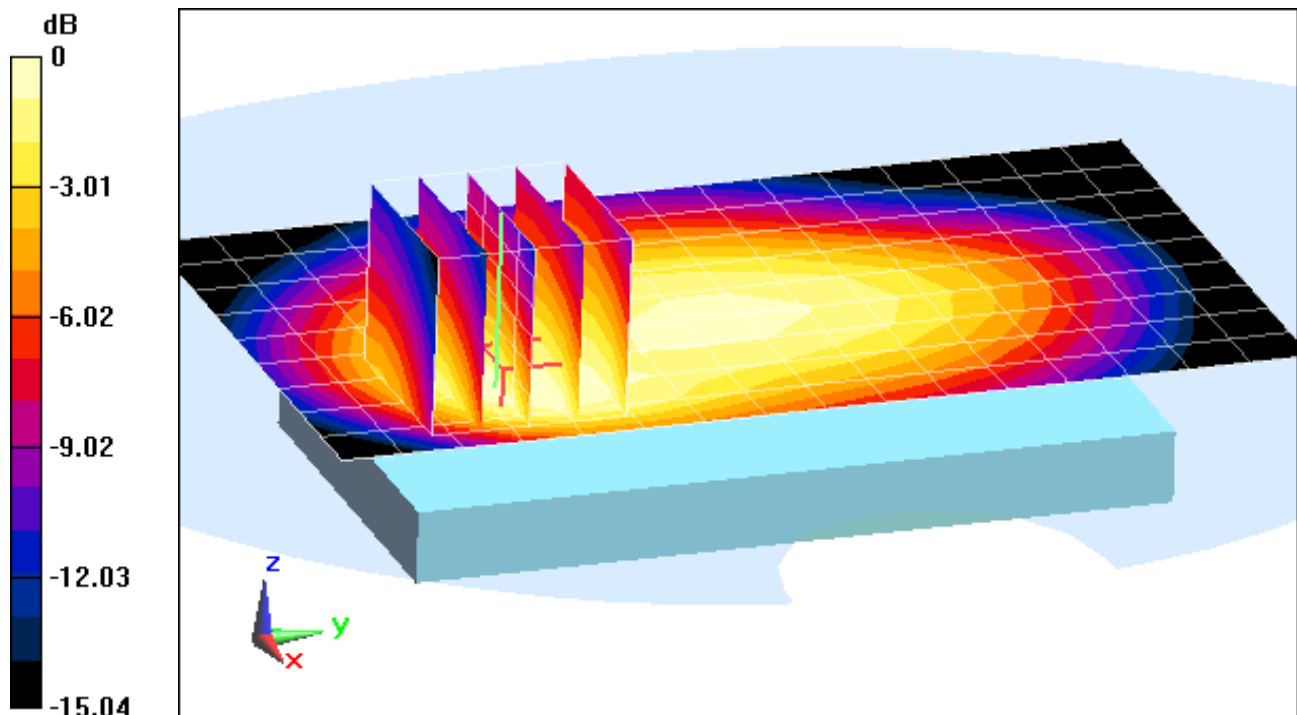

0 dB = 0.350 W/kg = -4.56 dBW/kg

# PCTEST ENGINEERING LABORATORY, INC.

**DUT: V65C6721A1; Type: Portable Handset; Serial: LTE SAR/HAC**

Communication System: LTE Band 12; Frequency: 707.5 MHz; Duty Cycle: 1:1

Medium: 750 Body Medium parameters used (interpolated):

$f = 707.5 \text{ MHz}$ ;  $\sigma = 0.92 \text{ S/m}$ ;  $\epsilon_r = 57.128$ ;  $\rho = 1000 \text{ kg/m}^3$

Phantom section: Flat Section; Space: 1.0 cm

Test Date: 12-14-2012; Ambient Temp: 22.4°C; Tissue Temp: 22.2°C

Probe: ES3DV3 - SN3263; ConvF(6.26, 6.26, 6.26); Calibrated: 5/18/2012;

Sensor-Surface: 4mm (Mechanical Surface Detection)

Electronics: DAE4 Sn1334; Calibrated: 5/7/2012

Phantom: SAM 5.0 front; Type: QD000P40CD; Serial: TP:-1648

Measurement SW: DASY52, Version 52.8 (3); SEMCAD X Version 14.6.8 (7028)

**Mode: LTE Band 12, Body SAR, Left Edge, Mid.ch**  
**10 MHz Bandwidth, QPSK, 1 RB, 0 RB Offset**

**Area Scan (6x16x1):** Measurement grid: dx=10mm, dy=10mm

**Zoom Scan (5x5x7)/Cube 0:** Measurement grid: dx=8mm, dy=8mm, dz=5mm

Reference Value = 20.382 V/m; Power Drift = -0.08 dB

Peak SAR (extrapolated) = 0.491 W/kg

**SAR(1 g) = 0.357 W/kg; SAR(10 g) = 0.250 W/kg**

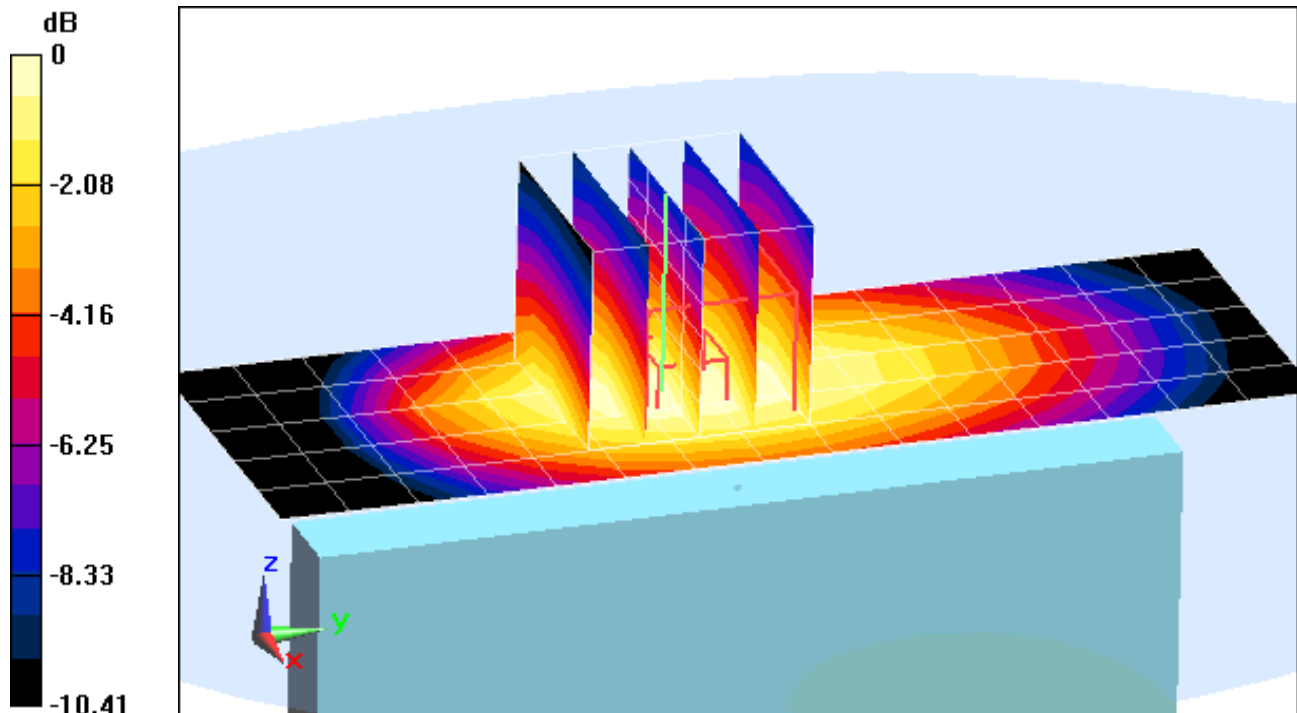

0 dB = 0.380 W/kg = -4.20 dBW/kg

# PCTEST ENGINEERING LABORATORY, INC.

**DUT: V65C6721A1; Type: Portable Handset; Serial: LTE SAR/HAC**

Communication System: LTE Band 17; Frequency: 710 MHz; Duty Cycle: 1:1

Medium: 750 Body Medium parameters used:

$f = 710 \text{ MHz}$ ;  $\sigma = 0.924 \text{ S/m}$ ;  $\epsilon_r = 56.99$ ;  $\rho = 1000 \text{ kg/m}^3$

Phantom section: Flat Section; Space: 1.0 cm

Test Date: 12-20-2012; Ambient Temp: 24.0°C; Tissue Temp: 22.2°C

Probe: ES3DV3 - SN3263; ConvF(6.26, 6.26, 6.26); Calibrated: 5/18/2012;

Sensor-Surface: 4mm (Mechanical Surface Detection)

Electronics: DAE4 Sn1334; Calibrated: 5/7/2012

Phantom: SAM 5.0 front; Type: QD000P40CD; Serial: TP:-1648

Measurement SW: DASY52, Version 52.8 (3); SEMCAD X Version 14.6.8 (7028)

**Mode: LTE Band 17, Body SAR, Back side, Mid.ch,  
QPSK, 10 MHz Bandwidth, 1 RB, 0 RB Offset**

**Area Scan (7x11x1):** Measurement grid: dx=15mm, dy=15mm

**Zoom Scan (6x5x7)/Cube 0:** Measurement grid: dx=8mm, dy=8mm, dz=5mm

Reference Value = 20.100 V/m; Power Drift = 0.00 dB

Peak SAR (extrapolated) = 0.584 W/kg

**SAR(1 g) = 0.370 W/kg; SAR(10 g) = 0.248 W/kg**

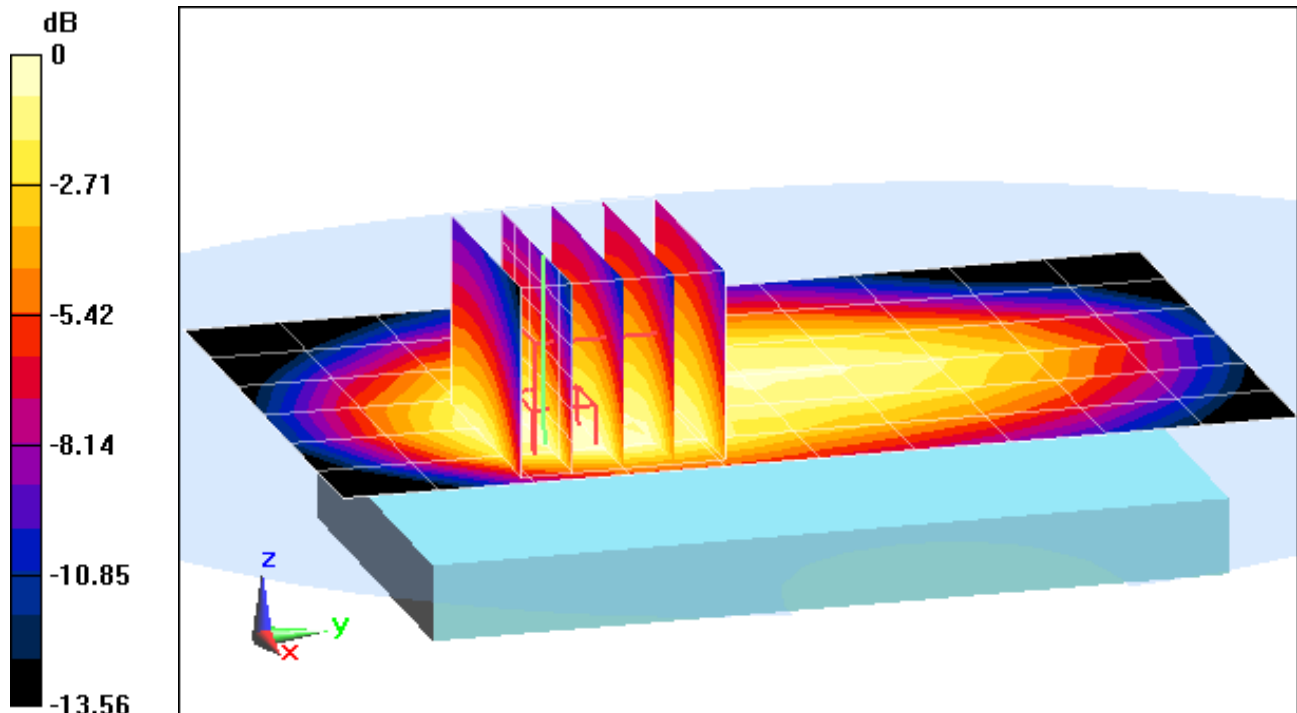

0 dB = 0.390 W/kg = -4.09 dBW/kg

# PCTEST ENGINEERING LABORATORY, INC.

**DUT: V65C6721A1; Type: Portable Handset; Serial: LTE SAR/HAC**

Communication System: LTE Band 17; Frequency: 710 MHz; Duty Cycle: 1:1

Medium: 750 Body Medium parameters used:

$f = 710 \text{ MHz}$ ;  $\sigma = 0.924 \text{ S/m}$ ;  $\epsilon_r = 56.99$ ;  $\rho = 1000 \text{ kg/m}^3$

Phantom section: Flat Section; Space: 1.0 cm

Test Date: 12-20-2012; Ambient Temp: 24.0°C; Tissue Temp: 22.2°C

Probe: ES3DV3 - SN3263; ConvF(6.26, 6.26, 6.26); Calibrated: 5/18/2012;

Sensor-Surface: 4mm (Mechanical Surface Detection)

Electronics: DAE4 Sn1334; Calibrated: 5/7/2012

Phantom: SAM 5.0 front; Type: QD000P40CD; Serial: TP:-1648

Measurement SW: DASY52, Version 52.8 (3); SEMCAD X Version 14.6.8 (7028)

**Mode: LTE Band 17, Body SAR, Left Edge, Mid.ch**  
**10 MHz Bandwidth, QPSK, 1 RB, 0 RB Offset**

**Area Scan (11x11x1):** Measurement grid: dx=5mm, dy=15mm

**Zoom Scan (5x5x7)/Cube 0:** Measurement grid: dx=8mm, dy=8mm, dz=5mm

Reference Value = 21.239 V/m; Power Drift = 0.00 dB

Peak SAR (extrapolated) = 0.529 W/kg

**SAR(1 g) = 0.388 W/kg; SAR(10 g) = 0.274 W/kg**

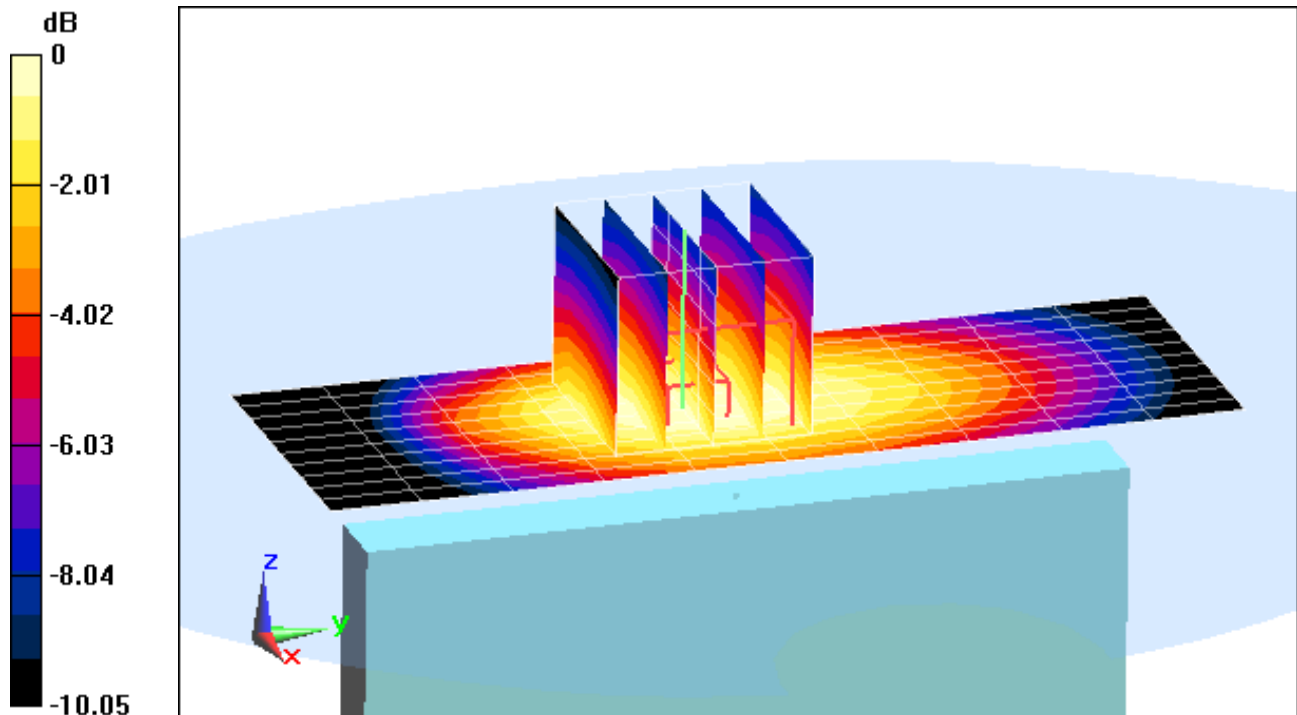

0 dB = 0.413 W/kg = -3.84 dBW/kg

# PCTEST ENGINEERING LABORATORY, INC.

**DUT: V65C6721A1; Type: Portable Handset; Serial: LTE SAR/HAC**

Communication System: LTE Band 5; Frequency: 836.5 MHz; Duty Cycle: 1:1

Medium: 835 Body Medium parameters used (interpolated):

$f = 836.5 \text{ MHz}$ ;  $\sigma = 0.994 \text{ S/m}$ ;  $\epsilon_r = 54.408$ ;  $\rho = 1000 \text{ kg/m}^3$

Phantom section: Flat Section; Space: 1.0 cm

Test Date: 12-10-2012; Ambient Temp: 21.9°C; Tissue Temp: 20.2°C

Probe: ES3DV3 - SN3263; ConvF(6.15, 6.15, 6.15); Calibrated: 5/18/2012;

Sensor-Surface: 4mm (Mechanical Surface Detection)

Electronics: DAE4 Sn1334; Calibrated: 5/7/2012

Phantom: SAM 5.0 front; Type: QD000P40CD; Serial: TP:-1648

Measurement SW: DASY52, Version 52.8 (3); SEMCAD X Version 14.6.8 (7028)

**Mode: LTE Band 5 (Cell.), Body SAR, Back side, Mid.ch**  
**10 MHz Bandwidth, QPSK, 1 RB, 49 RB Offset**

**Area Scan (7x11x1):** Measurement grid: dx=15mm, dy=15mm

**Zoom Scan (5x5x7)/Cube 0:** Measurement grid: dx=8mm, dy=8mm, dz=5mm

Reference Value = 19.983 V/m; Power Drift = -0.05 dB

Peak SAR (extrapolated) = 0.518 W/kg

**SAR(1 g) = 0.347 W/kg; SAR(10 g) = 0.233 W/kg**

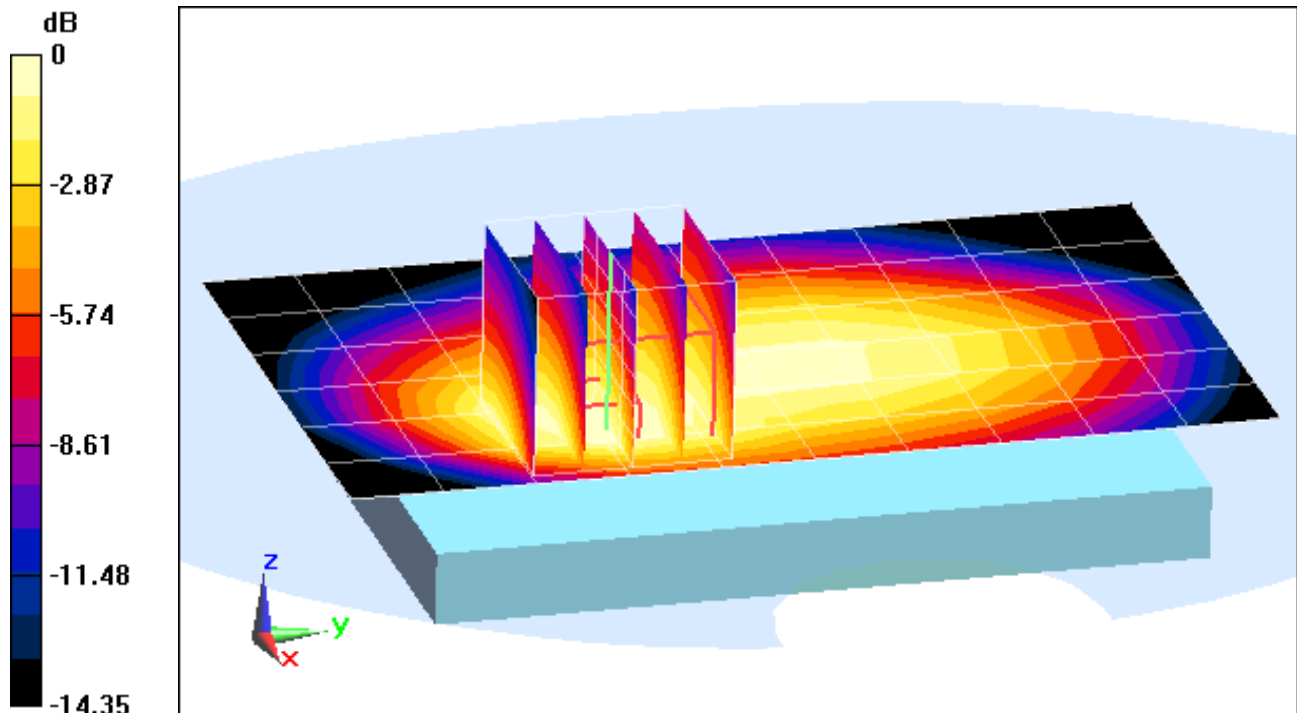

# PCTEST ENGINEERING LABORATORY, INC.

**DUT: V65C6721A1; Type: Portable Handset; Serial: LTE SAR/HAC**

Communication System: LTE Band 5; Frequency: 836.5 MHz; Duty Cycle: 1:1

Medium: 835 Body Medium parameters used (interpolated):

$f = 836.5 \text{ MHz}$ ;  $\sigma = 0.994 \text{ S/m}$ ;  $\epsilon_r = 54.408$ ;  $\rho = 1000 \text{ kg/m}^3$

Phantom section: Flat Section; Space: 1.0 cm

Test Date: 12-10-2012; Ambient Temp: 21.9°C; Tissue Temp: 20.2°C

Probe: ES3DV3 - SN3263; ConvF(6.15, 6.15, 6.15); Calibrated: 5/18/2012;

Sensor-Surface: 4mm (Mechanical Surface Detection)

Electronics: DAE4 Sn1334; Calibrated: 5/7/2012

Phantom: SAM 5.0 front; Type: QD000P40CD; Serial: TP:-1648

Measurement SW: DASY52, Version 52.8 (3); SEMCAD X Version 14.6.8 (7028)

**Mode: LTE Band 5 (Cell.), Body SAR, Left Edge, Mid.ch**  
**10 MHz Bandwidth, QPSK, 1 RB, 49 RB Offset**

**Area Scan (11x11x1):** Measurement grid: dx=5mm, dy=15mm

**Zoom Scan (5x5x7)/Cube 0:** Measurement grid: dx=8mm, dy=8mm, dz=5mm

Reference Value = 20.210 V/m; Power Drift = 0.02 dB

Peak SAR (extrapolated) = 0.501 W/kg

**SAR(1 g) = 0.366 W/kg; SAR(10 g) = 0.255 W/kg**

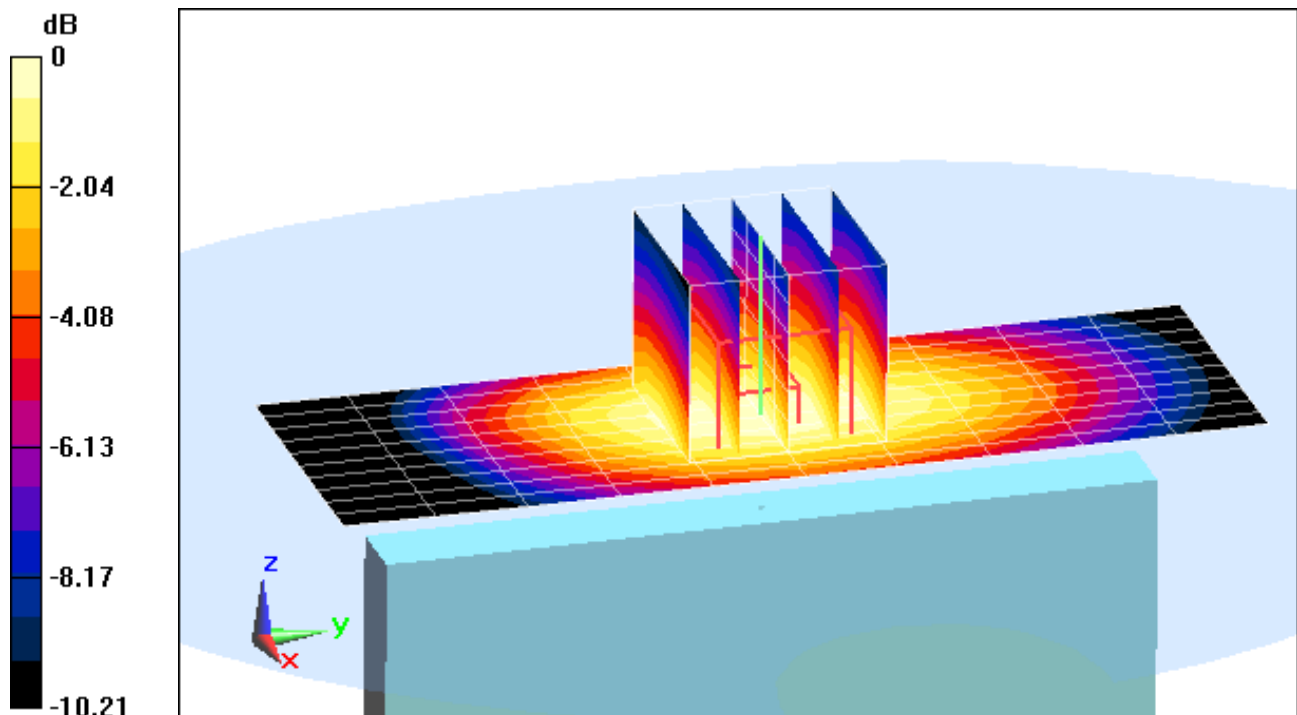

0 dB = 0.392 W/kg = -4.07 dBW/kg

# PCTEST ENGINEERING LABORATORY, INC.

**DUT: V65C6721A1; Type: Portable Handset; Serial: SAR LTE - Band 4**

Communication System: LTE Band 4 (AWS); Frequency: 1715 MHz; Duty Cycle: 1:1

Medium: 1750 Body Medium parameters used (interpolated):

$f = 1715 \text{ MHz}$ ;  $\sigma = 1.426 \text{ S/m}$ ;  $\epsilon_r = 52.466$ ;  $\rho = 1000 \text{ kg/m}^3$

Phantom section: Flat Section; Space: 1.0 cm

Test Date: 02-10-2013; Ambient Temp: 23.3°C; Tissue Temp: 22.3°C

Probe: ES3DV3 - SN3288; ConvF(5.18, 5.18, 5.18); Calibrated: 9/20/2012;

Sensor-Surface: 4mm (Mechanical Surface Detection)

Electronics: DAE4 Sn1323; Calibrated: 9/19/2012

Phantom: SAM v5.0 Left; Type: QD000P40CD; Serial: TP: 1687

Measurement SW: DASY52, Version 52.8 (5); SEMCAD X Version 14.6.8 (7028)

**Mode: LTE Band 4 (AWS), Body SAR, Back side, Low.ch**  
**10 MHz Bandwidth, QPSK, 1 RB, 0 RB Offset**

**Area Scan (7x11x1):** Measurement grid: dx=15mm, dy=15mm

**Zoom Scan (5x5x7)/Cube 0:** Measurement grid: dx=8mm, dy=8mm, dz=5mm

Reference Value = 21.470 V/m; Power Drift = 0.03 dB

Peak SAR (extrapolated) = 0.914 W/kg

**SAR(1 g) = 0.582 W/kg**

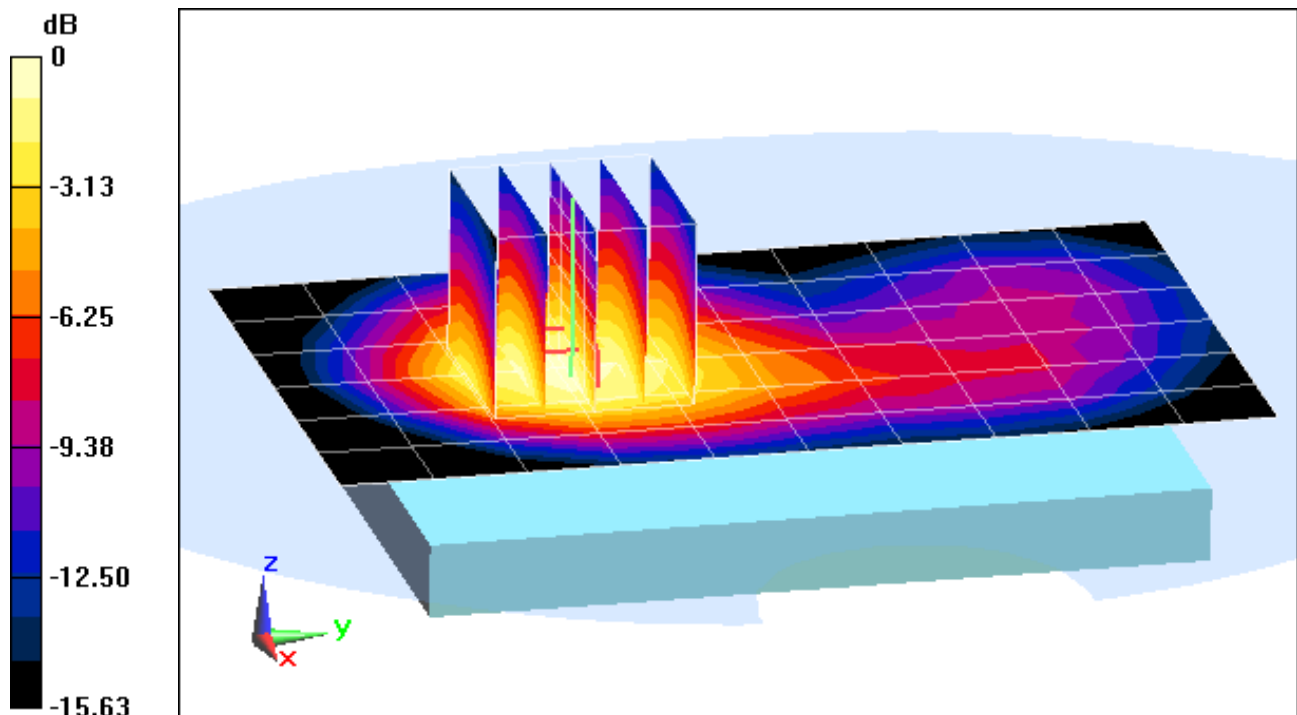

0 dB = 0.628 W/kg = -2.02 dBW/kg



# PCTEST ENGINEERING LABORATORY, INC.

**DUT: V65C6721A1; Type: Portable Handset; Serial: SAR LTE - Band 4**

Communication System: LTE Band 4 (AWS); Frequency: 1715 MHz; Duty Cycle: 1:1

Medium: 1750 Body Medium parameters used (interpolated):

$f = 1715 \text{ MHz}$ ;  $\sigma = 1.426 \text{ S/m}$ ;  $\epsilon_r = 52.466$ ;  $\rho = 1000 \text{ kg/m}^3$

Phantom section: Flat Section; Space: 1.0 cm

Test Date: 02-10-2013; Ambient Temp: 23.3°C; Tissue Temp: 22.3°C

Probe: ES3DV3 - SN3288; ConvF(5.18, 5.18, 5.18); Calibrated: 9/20/2012;

Sensor-Surface: 4mm (Mechanical Surface Detection)

Electronics: DAE4 Sn1323; Calibrated: 9/19/2012

Phantom: SAM v5.0 Left; Type: QD000P40CD; Serial: TP: 1687

Measurement SW: DASY52, Version 52.8 (5); SEMCAD X Version 14.6.8 (7028)

**Mode: LTE Band 4 (AWS), Body SAR, Front side, Low.ch**  
**10 MHz Bandwidth, QPSK, 1 RB, 0 RB Offset**

**Area Scan (7x11x1):** Measurement grid: dx=15mm, dy=15mm

**Zoom Scan (5x5x7)/Cube 0:** Measurement grid: dx=8mm, dy=8mm, dz=5mm

Reference Value = 22.497 V/m; Power Drift = -0.04 dB

Peak SAR (extrapolated) = 1.03 W/kg

**SAR(1 g) = 0.625 W/kg**

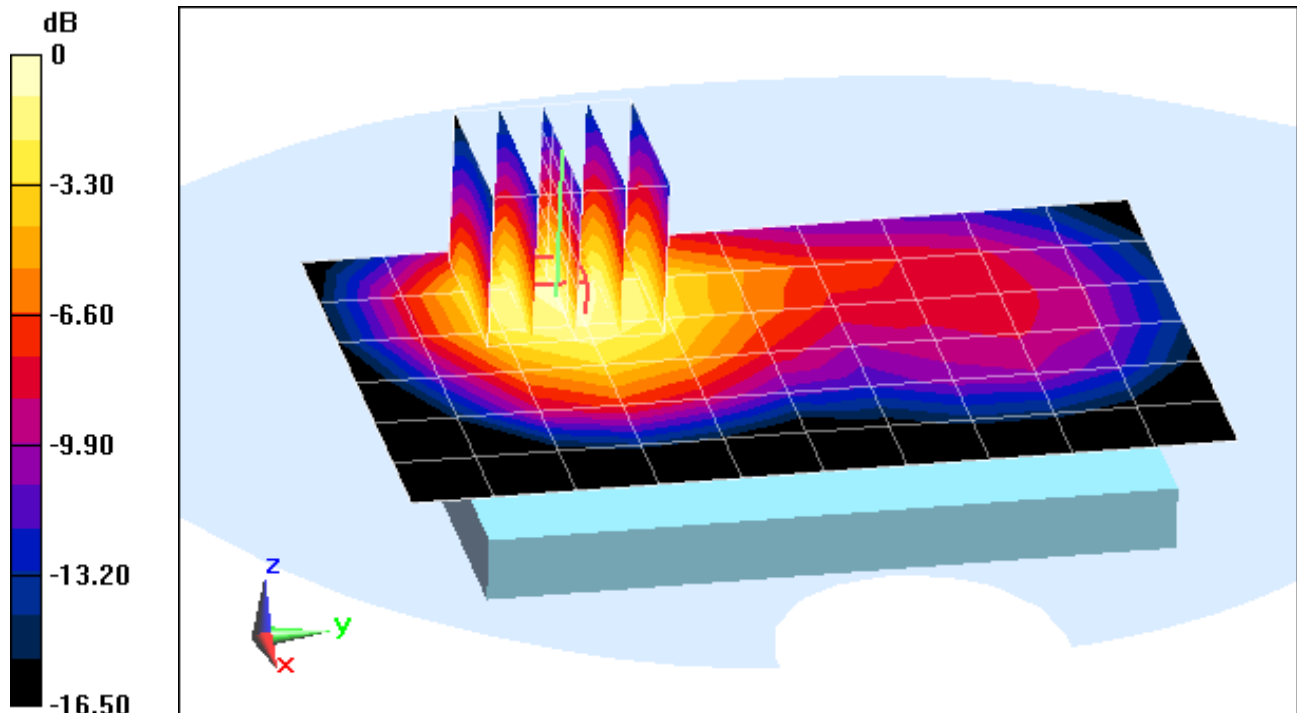

0 dB = 0.689 W/kg = -1.62 dBW/kg

# PCTEST ENGINEERING LABORATORY, INC.

**DUT: V65C6721A1; Type: Portable Handset; Serial: SAR LTE - Band 2**

Communication System: LTE Band 2; Frequency: 1880 MHz; Duty Cycle: 1:1

Medium: 1900 Body Medium parameters used:

$f = 1880 \text{ MHz}$ ;  $\sigma = 1.532 \text{ S/m}$ ;  $\epsilon_r = 52.88$ ;  $\rho = 1000 \text{ kg/m}^3$

Phantom section: Flat Section; Space: 1.0 cm

Test Date: 02-07-2013; Ambient Temp: 23.4°C; Tissue Temp: 22.1°C

Probe: ES3DV3 - SN3263; ConvF(4.76, 4.76, 4.76); Calibrated: 5/18/2012;

Sensor-Surface: 4mm (Mechanical Surface Detection)

Electronics: DAE4 Sn1334; Calibrated: 5/7/2012

Phantom: SAM 5.0 front; Type: QD000P40CD; Serial: TP:-1648

Measurement SW: DASY52, Version 52.8 (5); SEMCAD X Version 14.6.8 (7028)

**Mode: LTE Band 2 (PCS), Body SAR, Back side, Mid.ch**  
**10 MHz Bandwidth, QPSK, 1 RB, 0 RB Offset**

**Area Scan (7x11x1):** Measurement grid: dx=15mm, dy=15mm

**Zoom Scan (5x5x7)/Cube 0:** Measurement grid: dx=8mm, dy=8mm, dz=5mm

Reference Value = 23.333 V/m; Power Drift = -0.02 dB

Peak SAR (extrapolated) = 1.28 W/kg

**SAR(1 g) = 0.802 W/kg; SAR(10 g) = 0.498 W/kg**

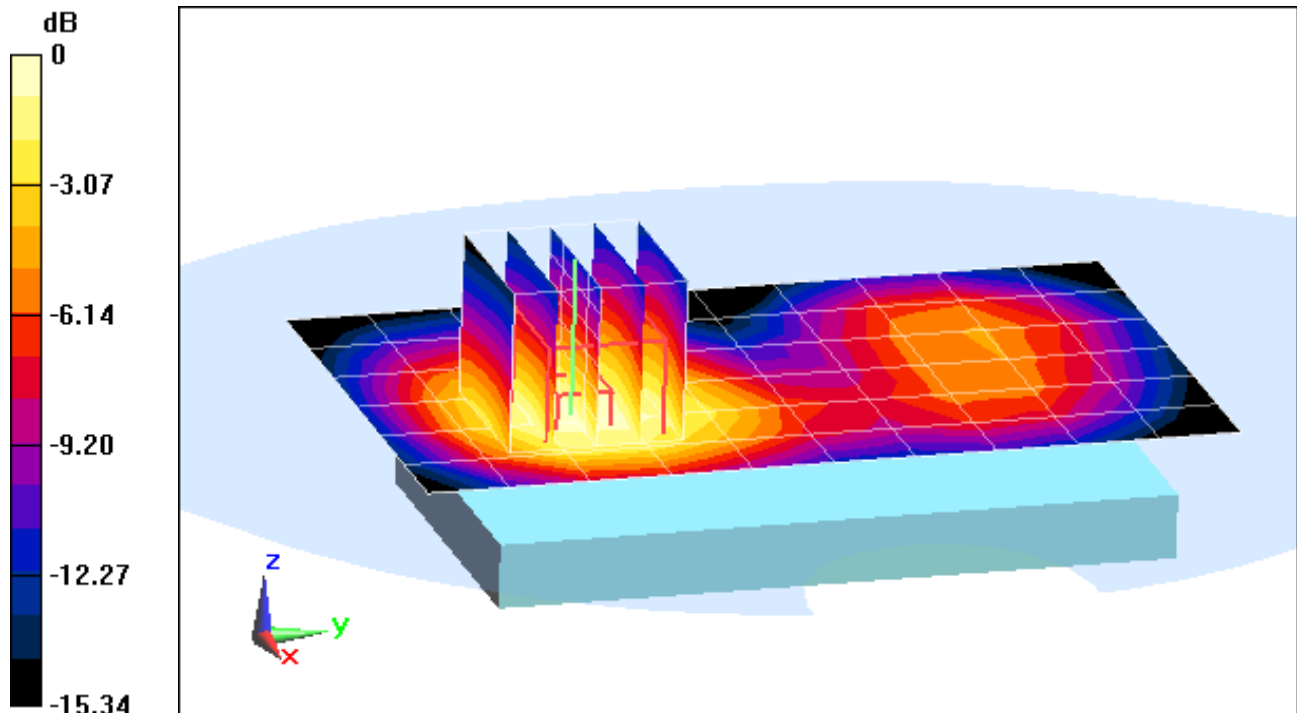

0 dB = 0.865 W/kg = -0.63 dBW/kg

# PCTEST ENGINEERING LABORATORY, INC.

**DUT: V65C6721A1; Type: Portable Handset; Serial: SAR LTE - Band 2**

Communication System: LTE Band 2 (PCS); Frequency: 1880 MHz; Duty Cycle: 1:1

Medium: 1900 Body Medium parameters used:

$f = 1880 \text{ MHz}$ ;  $\sigma = 1.532 \text{ S/m}$ ;  $\epsilon_r = 52.88$ ;  $\rho = 1000 \text{ kg/m}^3$

Phantom section: Flat Section; Space: 1.0 cm

Test Date: 02-07-2013; Ambient Temp: 23.4°C; Tissue Temp: 22.1°C

Probe: ES3DV3 - SN3263; ConvF(4.76, 4.76, 4.76); Calibrated: 5/18/2012;

Sensor-Surface: 4mm (Mechanical Surface Detection)

Electronics: DAE4 Sn1334; Calibrated: 5/7/2012

Phantom: SAM 5.0 front; Type: QD000P40CD; Serial: TP:-1648

Measurement SW: DASY52, Version 52.8 (5); SEMCAD X Version 14.6.8 (7028)

**Mode: LTE Band 2 (PCS), Body SAR, Front side, Mid.ch**  
**10 MHz Bandwidth, QPSK, 1 RB, 0 RB Offset**

**Area Scan (7x11x1):** Measurement grid: dx=15mm, dy=15mm

**Zoom Scan (5x5x7)/Cube 0:** Measurement grid: dx=8mm, dy=8mm, dz=5mm

Reference Value = 22.393 V/m; Power Drift = -0.10 dB

Peak SAR (extrapolated) = 1.22 W/kg

**SAR(1 g) = 0.830 W/kg; SAR(10 g) = 0.446 W/kg**

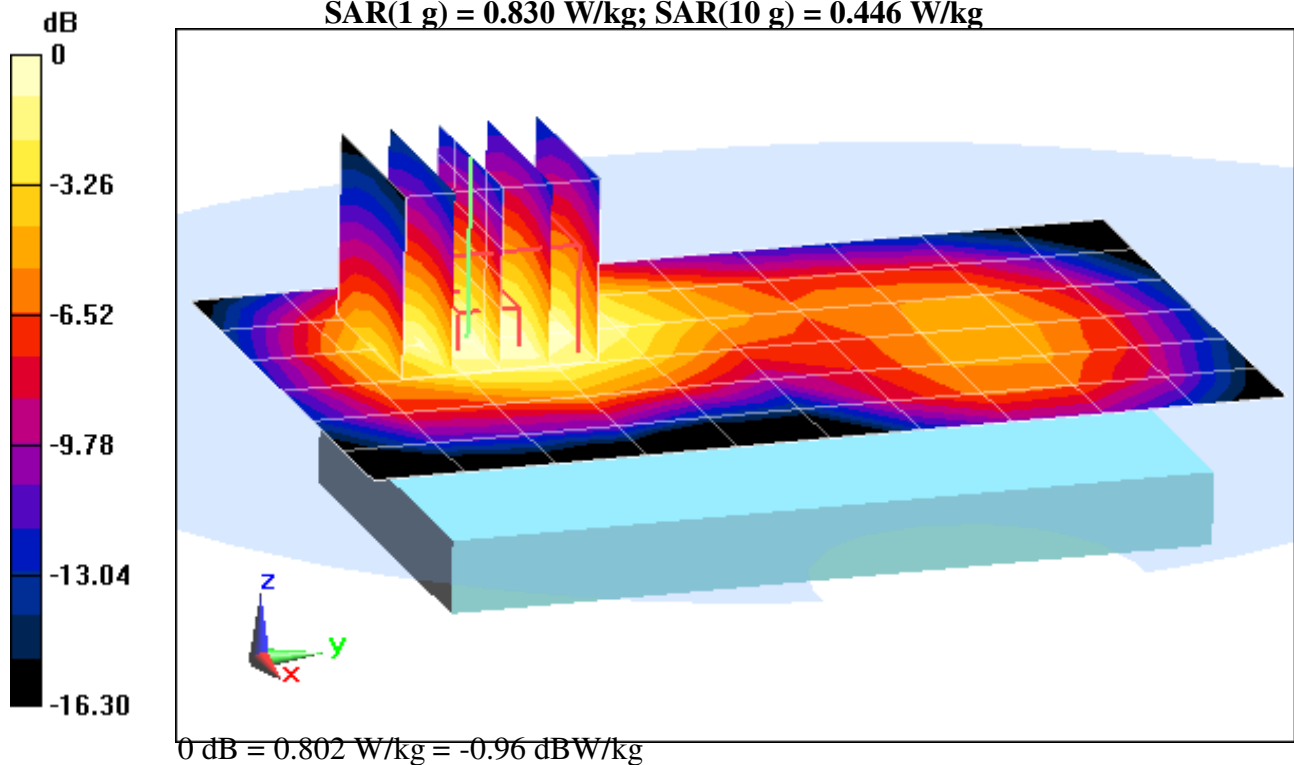

# PCTEST ENGINEERING LABORATORY, INC.

**DUT: V65C6721A1; Type: Portable Handset; Serial: WIFI/BT RADIATION**

Communication System: IEEE 802.11b; Frequency: 2437 MHz; Duty Cycle: 1:1

Medium: 2450 Body Medium parameters used (interpolated):

$$f = 2437 \text{ MHz}; \sigma = 1.963 \text{ S/m}; \epsilon_r = 50.71; \rho = 1000 \text{ kg/m}^3$$

Phantom section: Flat Section; Space: 1.0 cm

Test Date: 12-11-2012; Ambient Temp: 24.4°C; Tissue Temp: 23.3°C

Probe: ES3DV3 - SN3258; ConvF(4.28, 4.28, 4.28); Calibrated: 2/21/2012;

Sensor-Surface: 3mm (Mechanical Surface Detection)

Electronics: DAE4 Sn1272; Calibrated: 1/18/2012

Phantom: SAM Main; Type: SAM 4.0; Serial: TP-1114

Measurement SW: DASY4, Version 4.7 (80); SEMCAD X Version 14.6.8 (7028)

**Mode: IEEE 802.11b, Body SAR, Ch 06, 1 Mbps, Back Side**

**Area Scan (9x14x1):** Measurement grid: dx=12mm, dy=12mm

**Zoom Scan (7x7x7)/Cube 0:** Measurement grid: dx=5mm, dy=5mm, dz=5mm

Reference Value = 5.421 V/m; Power Drift = -0.16 dB

Peak SAR (extrapolated) = 0.141 W/kg

**SAR(1 g) = 0.053 W/kg; SAR(10 g) = 0.029 W/kg**

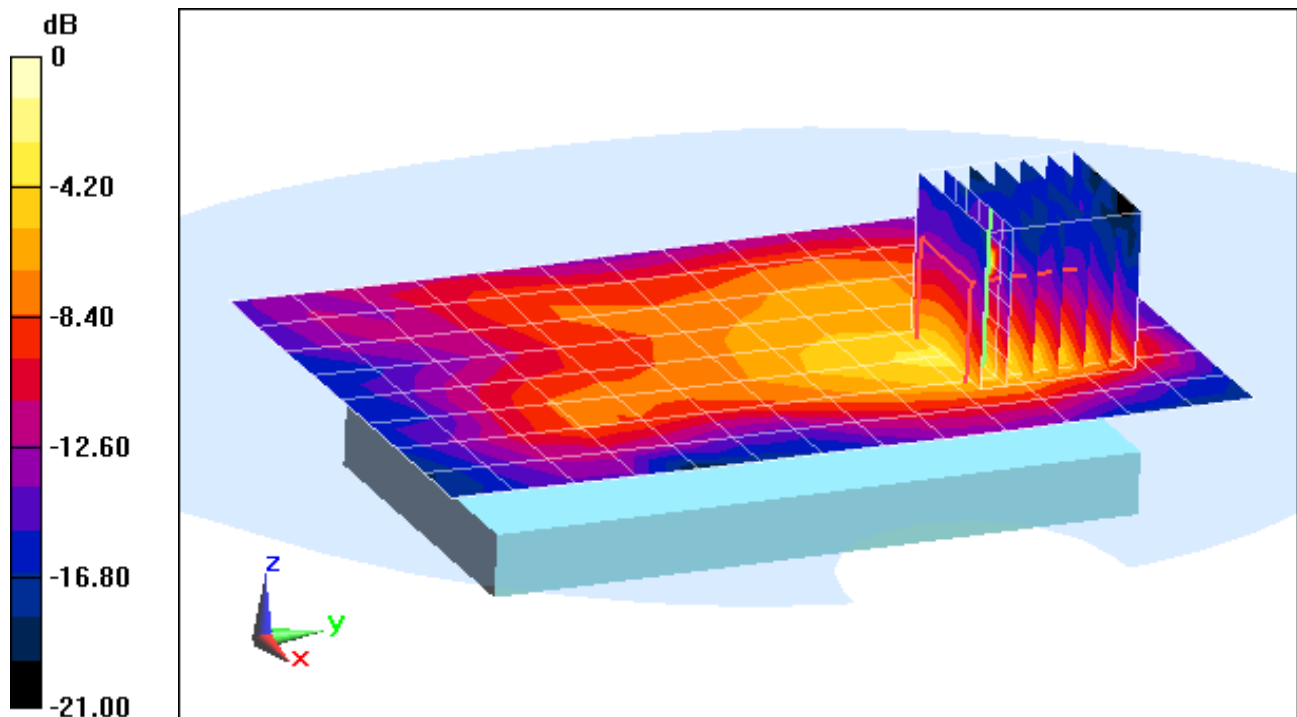

0 dB = 0.141 W/kg = -8.51 dBW/kg

# PCTEST ENGINEERING LABORATORY, INC.

**DUT: V65C6721A1; Type: Portable Handset; Serial: WIFI/BT RADIATION**

Communication System: IEEE 802.11b; Frequency: 2437 MHz; Duty Cycle: 1:1

Medium: 2450 Body Medium parameters used (interpolated):

$$f = 2437 \text{ MHz}; \sigma = 1.963 \text{ S/m}; \epsilon_r = 50.71; \rho = 1000 \text{ kg/m}^3$$

Phantom section: Flat Section; Space: 1.0 cm

Test Date: 12-11-2012; Ambient Temp: 24.4°C; Tissue Temp: 23.3°C

Probe: ES3DV3 - SN3258; ConvF(4.28, 4.28, 4.28); Calibrated: 2/21/2012;

Sensor-Surface: 3mm (Mechanical Surface Detection)

Electronics: DAE4 Sn1272; Calibrated: 1/18/2012

Phantom: SAM Main; Type: SAM 4.0; Serial: TP-1114

Measurement SW: DASY4, Version 4.7 (80); SEMCAD X Version 14.6.8 (7028)

**Mode: IEEE 802.11b, Body SAR, Ch 06, 1 Mbps, Front Side**

**Area Scan (9x14x1):** Measurement grid: dx=12mm, dy=12mm

**Zoom Scan (7x7x7)/Cube 0:** Measurement grid: dx=5mm, dy=5mm, dz=5mm

Reference Value = 6.598 V/m; Power Drift = -0.02 dB

Peak SAR (extrapolated) = 0.142 W/kg

**SAR(1 g) = 0.079 W/kg; SAR(10 g) = 0.047 W/kg**

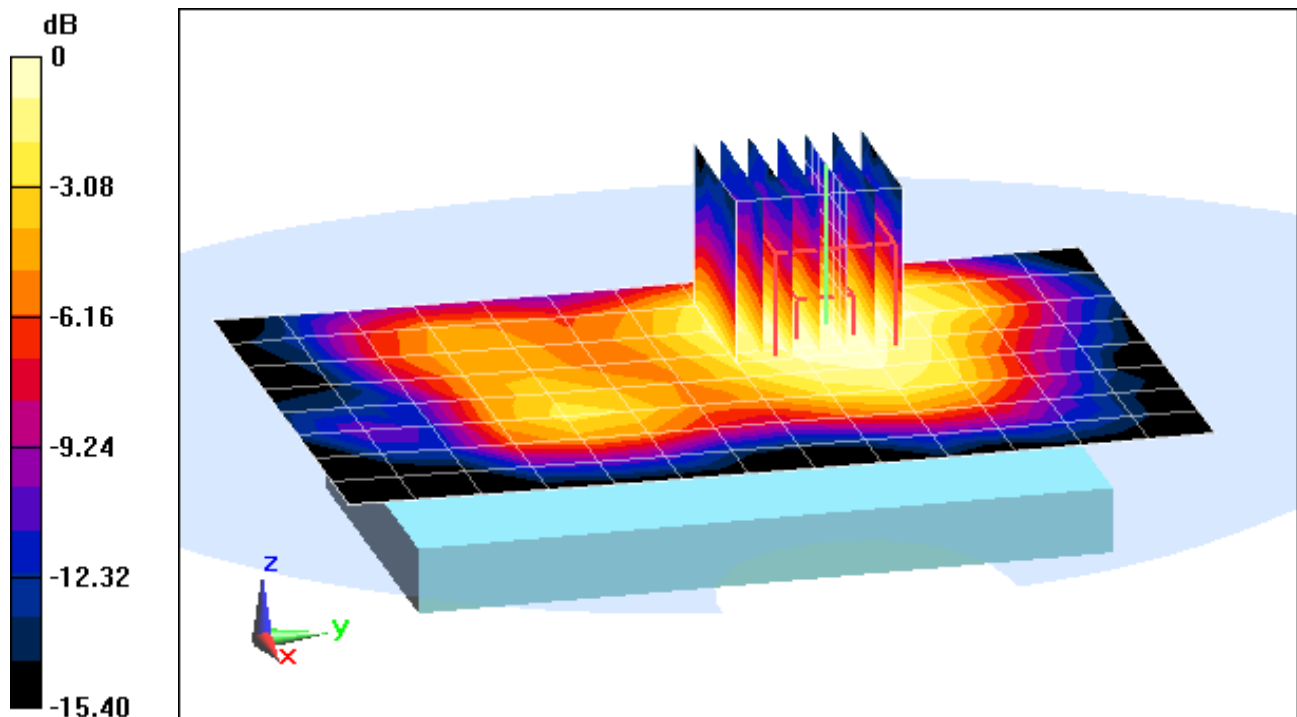

0 dB = 0.0952 W/kg = -10.21 dBW/kg

## APPENDIX B: SYSTEM VERIFICATION

# PCTEST ENGINEERING LABORATORY, INC.

**DUT: Dipole 750 MHz; Type: D750V3; Serial: 1054**

Communication System: CW; Frequency: 750 MHz; Duty Cycle: 1:1

Medium: 750 Head Medium parameters used (interpolated):

$f = 750 \text{ MHz}$ ;  $\sigma = 0.899 \text{ S/m}$ ;  $\epsilon_r = 41.88$ ;  $\rho = 1000 \text{ kg/m}^3$

Phantom section: Flat Section; Space: 1.5 cm

Test Date: 12-20-2012; Ambient Temp: 23.3°C; Tissue Temp: 22.2°C

Probe: ES3DV3 - SN3288; ConvF(6.67, 6.67, 6.67); Calibrated: 9/20/2012;

Sensor-Surface: 4mm (Mechanical Surface Detection)

Electronics: DAE4 Sn1323; Calibrated: 9/19/2012

Phantom: SAM v5.0 Left; Type: QD000P40CD; Serial: TP: 1687

Measurement SW: DASY52, Version 52.8 (3); SEMCAD X Version 14.6.8 (7028)

## 750 MHz System Verification

**Area Scan (7x15x1):** Measurement grid: dx=15mm, dy=15mm

**Zoom Scan (5x5x7)/Cube 0:** Measurement grid: dx=8mm, dy=8mm, dz=5mm

Input Power = 20 dBm (100 mW)

Peak SAR (extrapolated) = 1.21 W/kg

**SAR(1 g) = 0.806 W/kg; SAR(10 g) = 0.529 W/kg**

Deviation = -5.40%

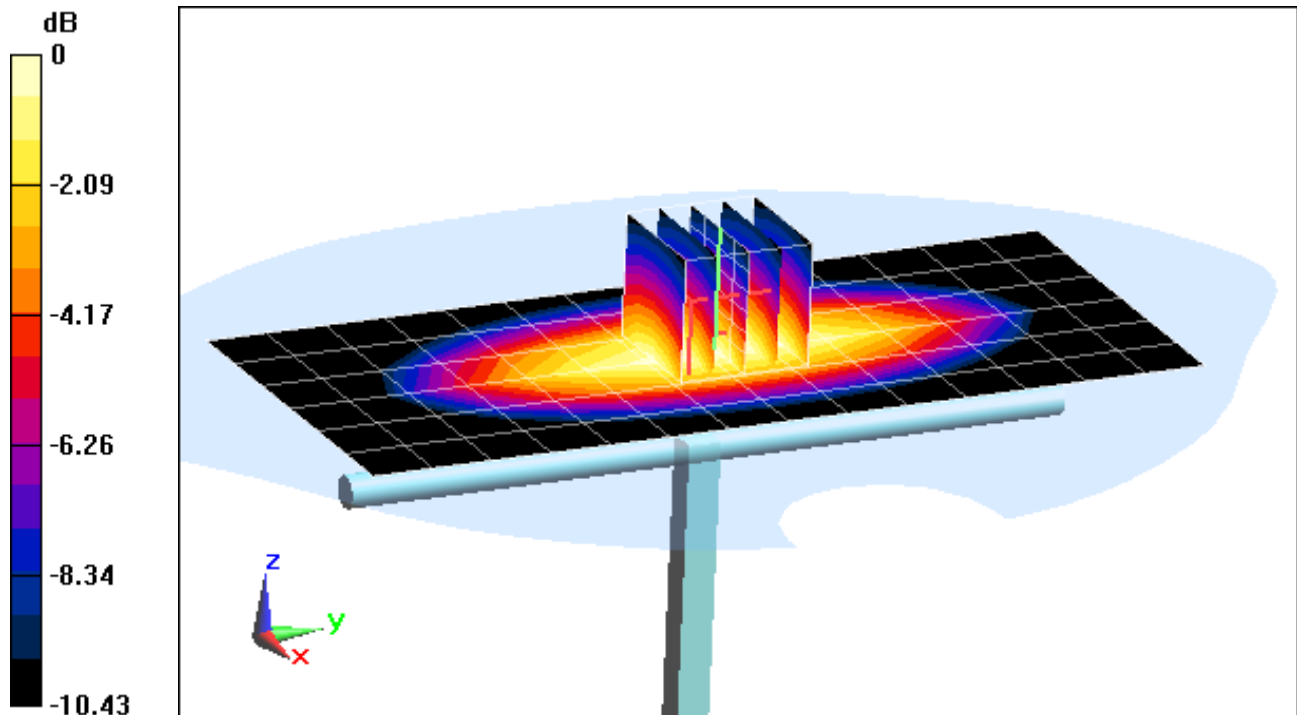

0 dB = 0.870 W/kg = -0.60 dBW/kg

# PCTEST ENGINEERING LABORATORY, INC.

**DUT: SAR Dipole 835 MHz; Type: D835V2; Serial: 4d132**

Communication System: CW; Frequency: 835 MHz; Duty Cycle: 1:1

Medium: 835 Head Medium parameters used:

$f = 835 \text{ MHz}$ ;  $\sigma = 0.882 \text{ S/m}$ ;  $\epsilon_r = 40.73$ ;  $\rho = 1000 \text{ kg/m}^3$

Phantom section: Flat Section; Space: 1.5 cm

Test Date: 12-17-2012; Ambient Temp: 21.3°C; Tissue Temp: 20.6°C

Probe: ES3DV3 - SN3288; ConvF(6.41, 6.41, 6.41); Calibrated: 9/20/2012;

Sensor-Surface: 4mm (Mechanical Surface Detection)

Electronics: DAE4 Sn1323; Calibrated: 9/19/2012

Phantom: SAM v5.0 front; Type: QD000P40CD; Serial: TP-1646

Measurement SW: DASY52, Version 52.8 (5); SEMCAD X Version 14.6.8 (7028)

## 835 MHz System Verification

**Area Scan (7x14x1):** Measurement grid: dx=15mm, dy=15mm

**Zoom Scan (5x5x7)/Cube 0:** Measurement grid: dx=8mm, dy=8mm, dz=5mm

Input Power = 20 dBm (100 mW)

Peak SAR (extrapolated) = 1.43 W/kg

**SAR(1 g) = 0.966 W/kg; SAR(10 g) = 0.632 W/kg**

Deviation = 2.22%

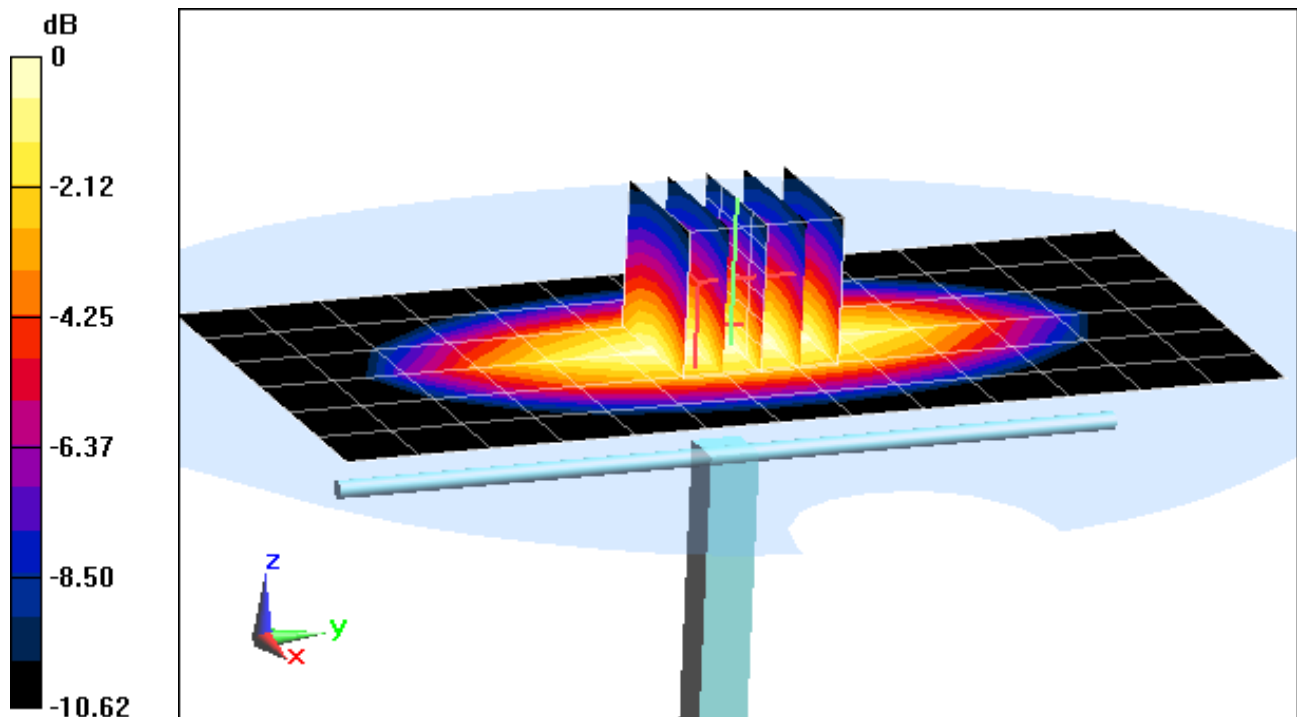

0 dB = 1.04 W/kg = 0.17 dBW/kg



# PCTEST ENGINEERING LABORATORY, INC.

**DUT: Dipole 835 MHz; Type: D835V2; Serial: 4d119**

Communication System: CW; Frequency: 835 MHz; Duty Cycle: 1:1

Medium: 835 Head Medium parameters used:

$f = 835 \text{ MHz}$ ;  $\sigma = 0.912 \text{ S/m}$ ;  $\epsilon_r = 40.942$ ;  $\rho = 1000 \text{ kg/m}^3$

Phantom section: Flat Section; Space: 1.5 cm

Test Date: 02-11-2013; Ambient Temp: 24.4°C; Tissue Temp: 23.4°C

Probe: ES3DV2 - SN3022; ConvF(6.03, 6.03, 6.03); Calibrated: 8/28/2012;

Sensor-Surface: 4mm (Mechanical Surface Detection)

Electronics: DAE4 Sn1322; Calibrated: 8/24/2012

Phantom: SAM Main; Type: SAM 4.0; Serial: TP-1406

Measurement SW: DASY4, Version 4.7 (80); SEMCAD X Version 14.6.8 (7028)

## 835MHz System Verification

**Area Scan (7x13x1):** Measurement grid: dx=15mm, dy=15mm

**Zoom Scan (5x5x7)/Cube 0:** Measurement grid: dx=8mm, dy=8mm, dz=5mm

Input Power = 20 dBm (100 mW)

Peak SAR (extrapolated) = 1.46 W/kg

**SAR(1 g) = 0.993 W/kg; SAR(10 g) = 0.651 W/kg**

Deviation = 5.41%

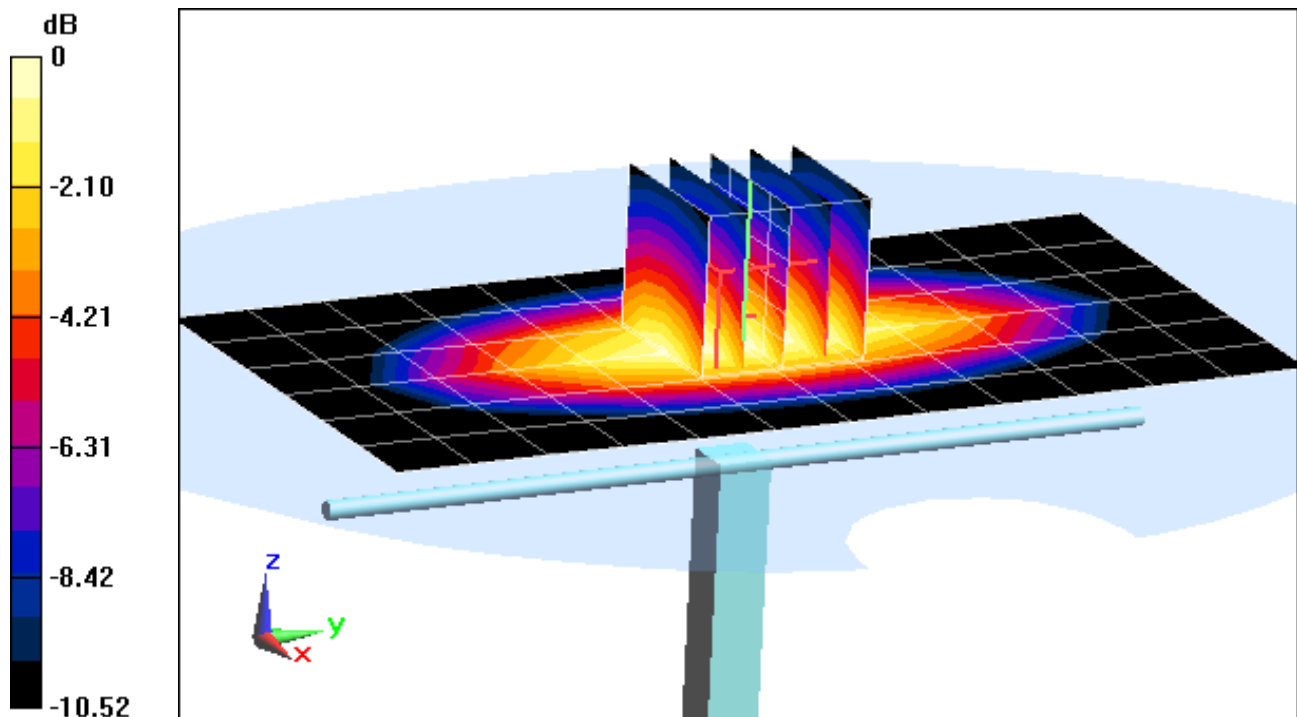

0 dB = 1.08 W/kg = 0.33 dBW/kg

# PCTEST ENGINEERING LABORATORY, INC.

**DUT: Dipole 1750 MHz; Type: D1750V2; Serial: 1051**

Communication System: CW; Frequency: 1750 MHz; Duty Cycle: 1:1

Medium: 1750 Head Medium parameters used:

$f = 1750 \text{ MHz}$ ;  $\sigma = 1.368 \text{ S/m}$ ;  $\epsilon_r = 39.83$ ;  $\rho = 1000 \text{ kg/m}^3$

Phantom section: Flat Section ; Space: 1.0 cm

Test Date: 02-07-2013; Ambient Temp: 23.4°C; Tissue Temp: 21.4°C

Probe: ES3DV3 - SN3288; ConvF(5.51, 5.51, 5.51); Calibrated: 9/20/2012;

Sensor-Surface: 4mm (Mechanical Surface Detection)

Electronics: DAE4 Sn1323; Calibrated: 9/19/2012

Phantom: SAM v5.0 front; Type: QD000P40CD; Serial: TP-1646

Measurement SW: DASY52, Version 52.8 (5); SEMCAD X Version 14.6.8 (7028)

## 1750 MHz System Verification

**Area Scan (7x9x1):** Measurement grid: dx=15mm, dy=15mm

**Zoom Scan (5x5x7)/Cube 0:** Measurement grid: dx=8mm, dy=8mm, dz=5mm

Input Power: 20.0 dBm (100 mW)

Peak SAR (extrapolated) = 6.24 W/kg

**SAR(1 g) = 3.44 W/kg; SAR(10 g) = 1.82 W/kg**

Deviation: -6.01%

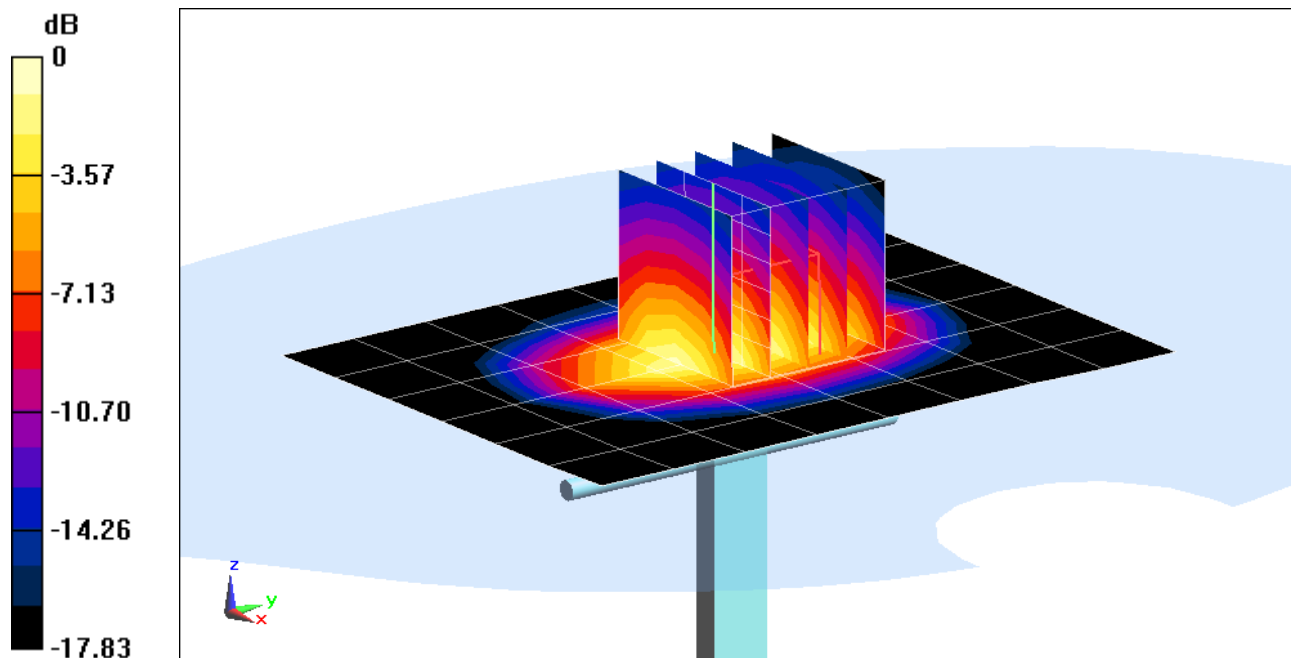

0 dB = 3.79 W/kg = 5.79 dBW/kg

# PCTEST ENGINEERING LABORATORY, INC.

**DUT: Dipole 1750 MHz; Type: D1750V2; Serial: 1051**

Communication System: CW; Frequency: 1750 MHz; Duty Cycle: 1:1

Medium: 1750 Head Medium parameters used:

$f = 1750 \text{ MHz}$ ;  $\sigma = 1.392 \text{ S/m}$ ;  $\epsilon_r = 38.779$ ;  $\rho = 1000 \text{ kg/m}^3$

Phantom section: Flat Section; Space: 1.0 cm

Test Date: 02-22-2013; Ambient Temp: 24.1°C; Tissue Temp: 21.9°C

Probe: ES3DV3 - SN3213; ConvF(5.22, 5.22, 5.22); Calibrated: 4/24/2012;

Sensor-Surface: 4mm (Mechanical Surface Detection)

Electronics: DAE4 Sn665; Calibrated: 4/19/2012

Phantom: SAM Right; Type: QD000P40CD; Serial: 1686

Measurement SW: DASY52, Version 52.8 (5); SEMCAD X Version 14.6.8 (7028)

## 1750 MHz System Verification

**Area Scan (7x9x1):** Measurement grid: dx=15mm, dy=15mm

**Zoom Scan (5x5x7)/Cube 0:** Measurement grid: dx=8mm, dy=8mm, dz=5mm

Input Power = 20 dBm (100 mW)

Peak SAR (extrapolated) = 6.80 W/kg

**SAR(1 g) = 3.73 W/kg; SAR(10 g) = 1.96 W/kg**

Deviation = 1.91%

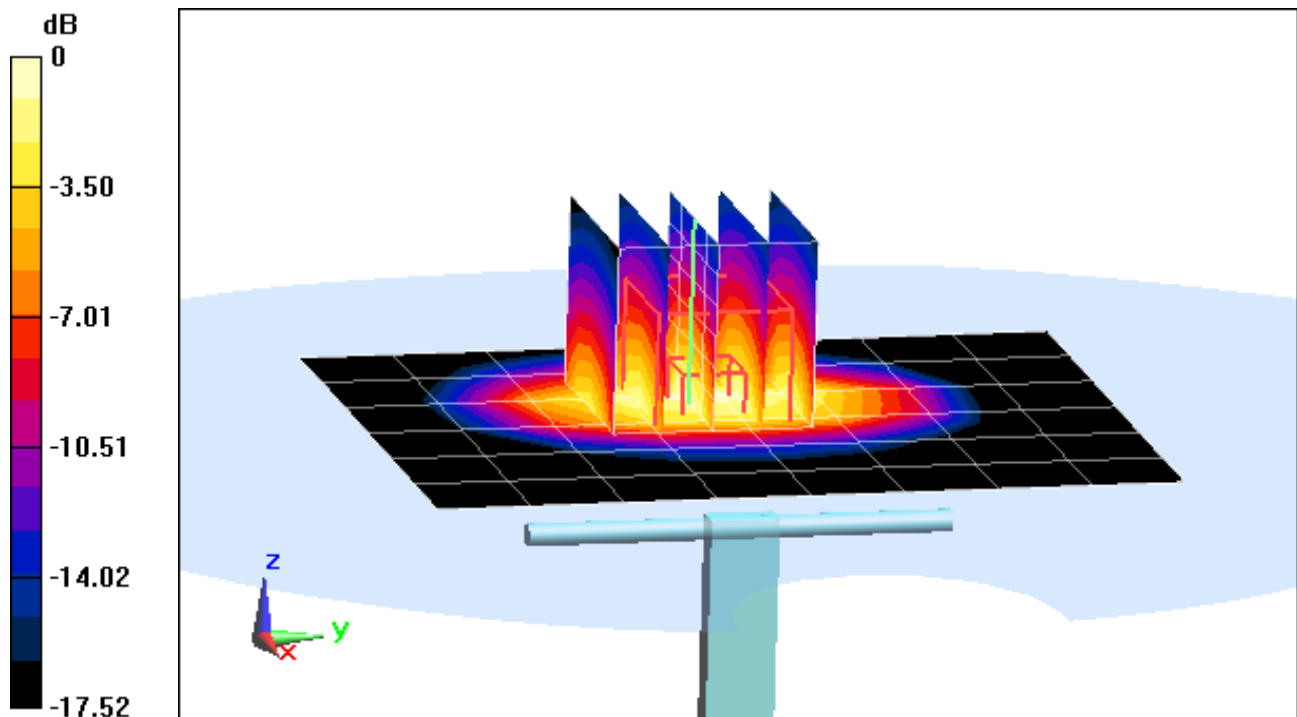

0 dB = 4.16 W/kg = 6.19 dBW/kg

# PCTEST ENGINEERING LABORATORY, INC.

**DUT: SAR Dipole 1900 MHz; Type: D1900V2; Serial: 5d149**

Communication System: CW; Frequency: 1900 MHz; Duty Cycle: 1:1

Medium: 1900 Head; Medium parameters used (interpolated):

$f = 1900 \text{ MHz}$ ;  $\sigma = 1.45 \text{ S/m}$ ;  $\epsilon_r = 39.137$ ;  $\rho = 1000 \text{ kg/m}^3$

Phantom section: Flat Section; Space: 1.0 cm

Test Date: 02-08-2013; Ambient Temp: 24.3°C; Tissue Temp: 21.9°C

Probe: ES3DV3 - SN3263; ConvF(5.09, 5.09, 5.09); Calibrated: 5/18/2012;

Sensor-Surface: 4mm (Mechanical Surface Detection)

Electronics: DAE4 Sn1334; Calibrated: 5/7/2012

Phantom: SAM V5.0 Right; Type: QD000P40CD; Serial: 1647

Measurement SW: DASY52, Version 52.8 (5);SEMCAD X Version 14.6.8 (7028)

## 1900 MHz System Verification

**Area Scan (7x10x1):** Measurement grid: dx=15mm, dy=15mm

**Zoom Scan (5x5x7)/Cube 0:** Measurement grid: dx=8mm, dy=8mm, dz=5mm

Input Power = 20.0 dBm (100 mW)

Peak SAR (extrapolated) = 7.48 W/kg

**SAR(1 g) = 3.94 W/kg; SAR(10 g) = 2.03 W/kg**

Deviation = 0.25%

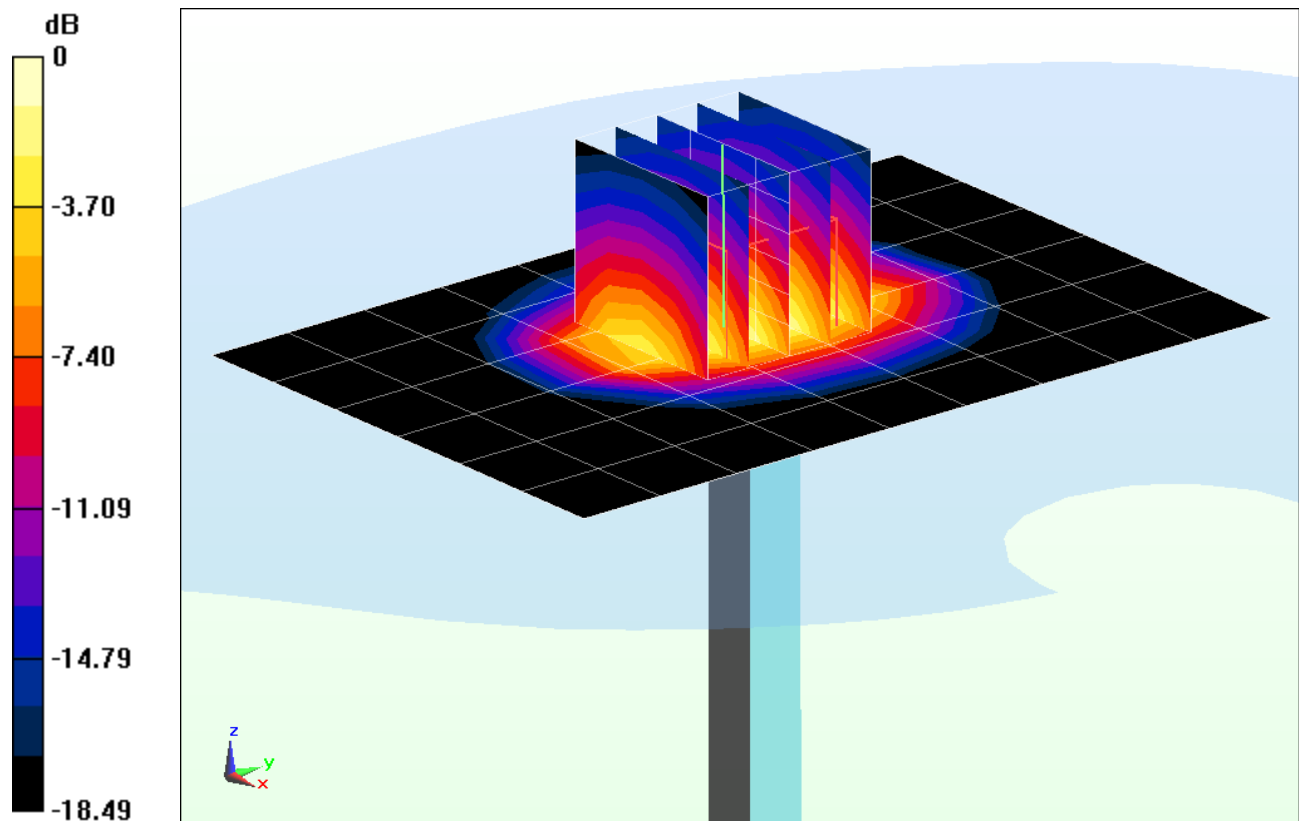

0 dB = 4.39 W/kg = 6.42 dBW/kg

# PCTEST ENGINEERING LABORATORY, INC.

**DUT: SAR Dipole 1900 MHz; Type: D1900V2; Serial: 5d149**

Communication System: CW; Frequency: 1900 MHz; Duty Cycle: 1:1

Medium: 1900 Head Medium parameters used (interpolated):

$f = 1900 \text{ MHz}$ ;  $\sigma = 1.45 \text{ S/m}$ ;  $\epsilon_r = 39.137$ ;  $\rho = 1000 \text{ kg/m}^3$

Phantom section: Flat Section; Space: 1.0 cm

Test Date: 02-08-2013; Ambient Temp: 22.8°C; Tissue Temp: 21.3°C

Probe: ES3DV3 - SN3213; ConvF(5.02, 5.02, 5.02); Calibrated: 4/24/2012;

Sensor-Surface: 4mm (Mechanical Surface Detection)

Electronics: DAE4 Sn665; Calibrated: 4/19/2012

Phantom: SAM Right; Type: QD000P40CD; Serial: 1686

Measurement SW: DASY52, Version 52.8 (5); SEMCAD X Version 14.6.8 (7028)

## 1900 MHz System Verification

**Area Scan (7x10x1):** Measurement grid: dx=15mm, dy=15mm

**Zoom Scan (5x5x7)/Cube 0:** Measurement grid: dx=8mm, dy=8mm, dz=5mm

Input Power = 20 dBm (100 mW)

Peak SAR (extrapolated) = 7.69 W/kg

**SAR(1 g) = 4.15 W/kg; SAR(10 g) = 2.14 W/kg**

Deviation = 5.60%

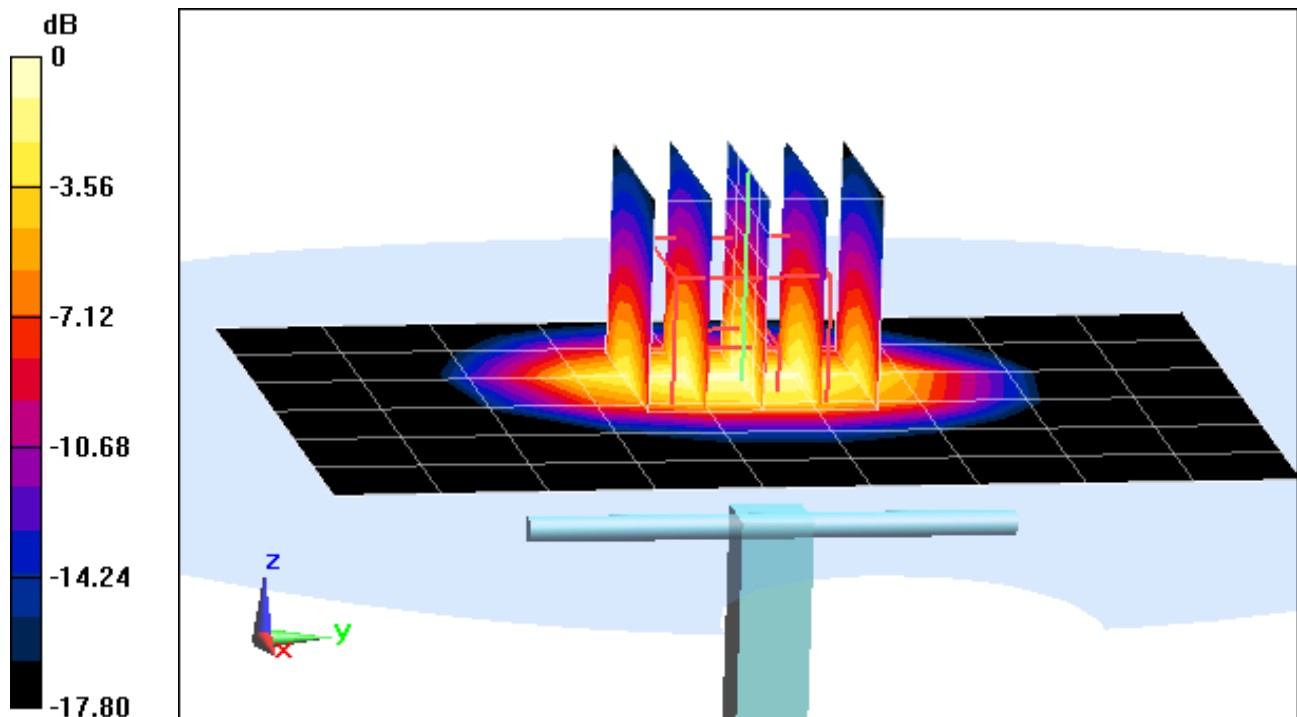

0 dB = 4.67 W/kg = 6.69 dBW/kg

# PCTEST ENGINEERING LABORATORY, INC.

**DUT: SAR Dipole 1900 MHz; Type: D1900V2; Serial: 5d149**

Communication System: CW; Frequency: 1900 MHz; Duty Cycle: 1:1

Medium: 1900 Head Medium parameters used (interpolated):

$f = 1900 \text{ MHz}$ ;  $\sigma = 1.444 \text{ S/m}$ ;  $\epsilon_r = 40.439$ ;  $\rho = 1000 \text{ kg/m}^3$

Phantom section: Flat Section; Space: 1.0 cm

Test Date: 02-20-2013; Ambient Temp: 23.9°C; Tissue Temp: 23.5°C

Probe: ES3DV3 - SN3288; ConvF(5.28, 5.28, 5.28); Calibrated: 9/20/2012;

Sensor-Surface: 4mm (Mechanical Surface Detection)

Electronics: DAE4 Sn1323; Calibrated: 9/19/2012

Phantom: SAM v5.0 Left; Type: QD000P40CD; Serial: TP: 1687

Measurement SW: DASY52, Version 52.8 (5); SEMCAD X Version 14.6.8 (7028)

## 1900 MHz System Verification

**Area Scan (7x10x1):** Measurement grid: dx=15mm, dy=15mm

**Zoom Scan (5x5x7)/Cube 0:** Measurement grid: dx=8mm, dy=8mm, dz=5mm

Input Power = 20 dBm (100 mW)

Peak SAR (extrapolated) = 7.29 W/kg

**SAR(1 g) = 3.94 W/kg; SAR(10 g) = 2.05 W/kg**

Deviation = 0.25%

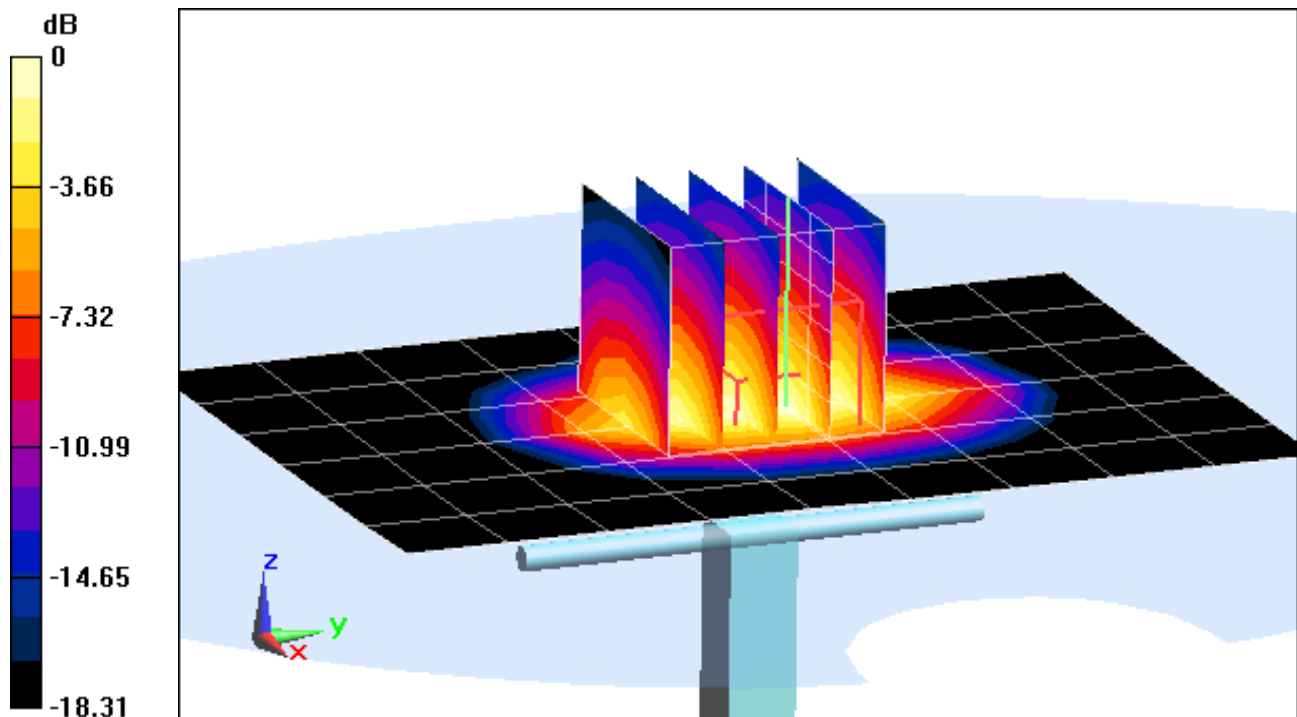

0 dB = 4.33 W/kg = 6.36 dBW/kg

# PCTEST ENGINEERING LABORATORY, INC.

**DUT: SAR Dipole 2450 MHz; Type: D2450V2; Serial: 719**

Communication System: CW; Frequency: 2450 MHz; Duty Cycle: 1:1

Medium: 2450 Head Medium parameters used:

$f = 2450 \text{ MHz}$ ;  $\sigma = 1.847 \text{ S/m}$ ;  $\epsilon_r = 38.27$ ;  $\rho = 1000 \text{ kg/m}^3$

Phantom section: Flat Section; Space: 1.0 cm

Test Date: 12-18-2012; Ambient Temp: 23.3°C; Tissue Temp: 21.4°C

Probe: ES3DV3 - SN3258; ConvF(4.46, 4.46, 4.46); Calibrated: 2/21/2012;

Sensor-Surface: 3mm (Mechanical Surface Detection)

Electronics: DAE4 Sn1272; Calibrated: 1/18/2012

Phantom: SAM Main; Type: SAM 4.0; Serial: TP-1114

Measurement SW: DASY4, Version 4.7 (80); SEMCAD X Version 14.6.8 (7028)

## 2450MHz System Verification

**Area Scan (6x9x1):** Measurement grid: dx=12mm, dy=12mm

**Zoom Scan (7x7x7)/Cube 0:** Measurement grid: dx=5mm, dy=5mm, dz=5mm

Input Power = 16 dBm (40 mW)

Peak SAR (extrapolated) = 4.71 W/kg

**SAR(1 g) = 2.27 W/kg; SAR(10 g) = 1.04 W/kg**

Deviation = 7.69%

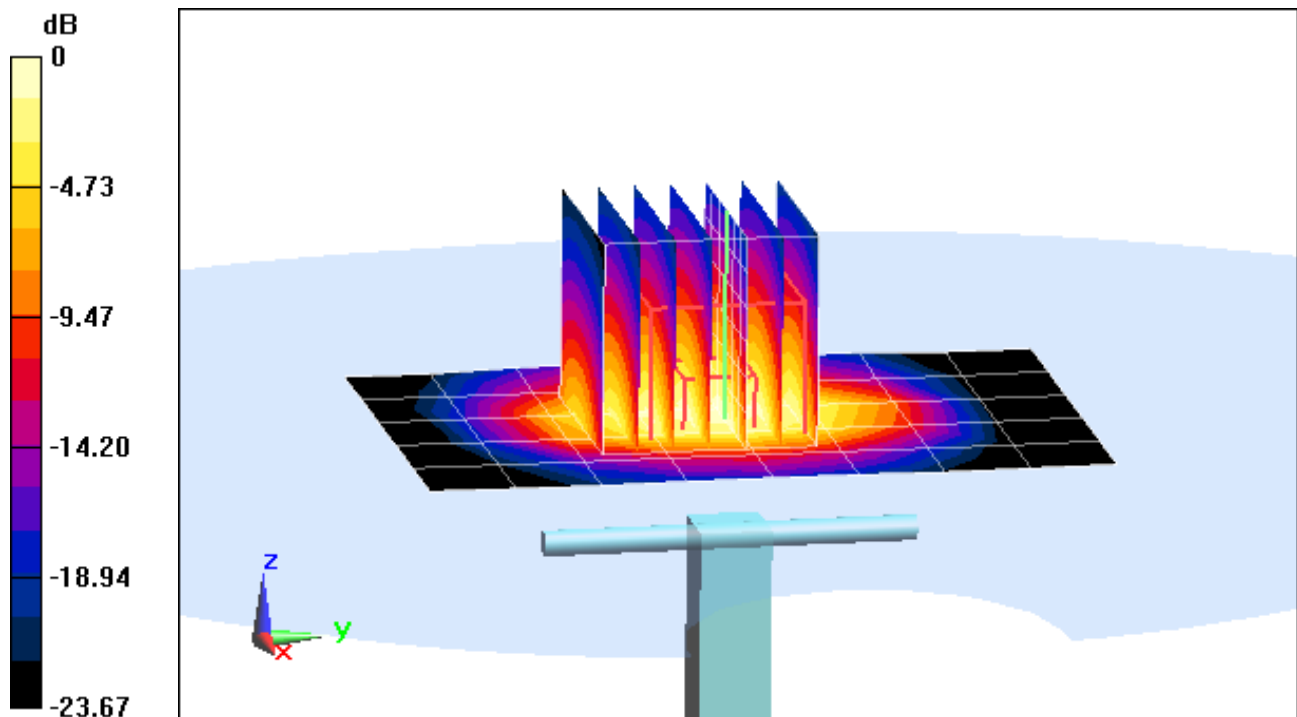

0 dB = 2.88 W/kg = 4.59 dBW/kg

# PCTEST ENGINEERING LABORATORY, INC.

**DUT: Dipole 750 MHz; Type: D750V3; Serial: 1054**

Communication System: CW; Frequency: 750 MHz; Duty Cycle: 1:1

Medium: 750 Body Medium parameters used (interpolated):

$f = 750 \text{ MHz}$ ;  $\sigma = 0.958 \text{ S/m}$ ;  $\epsilon_r = 56.887$ ;  $\rho = 1000 \text{ kg/m}^3$

Phantom section: Flat Section; Space: 1.5 cm

Test Date: 12-14-2012; Ambient Temp: 22.4°C; Tissue Temp: 22.2°C

Probe: ES3DV3 - SN3263; ConvF(6.26, 6.26, 6.26); Calibrated: 5/18/2012;

Sensor-Surface: 4mm (Mechanical Surface Detection)

Electronics: DAE4 Sn1334; Calibrated: 5/7/2012

Phantom: SAM 5.0 front; Type: QD000P40CD; Serial: TP:-1648

Measurement SW: DASY52, Version 52.8 (3); SEMCAD X Version 14.6.8 (7028)

## 750 MHz System Verification

**Area Scan (7x15x1):** Measurement grid: dx=15mm, dy=15mm

**Zoom Scan (5x5x7)/Cube 0:** Measurement grid: dx=8mm, dy=8mm, dz=5mm

Input Power = 17.56 dBm (57 mW)

Peak SAR (extrapolated) = 0.682 W/kg

**SAR(1 g) = 0.469 W/kg; SAR(10 g) = 0.312 W/kg**

Deviation = -6.92%

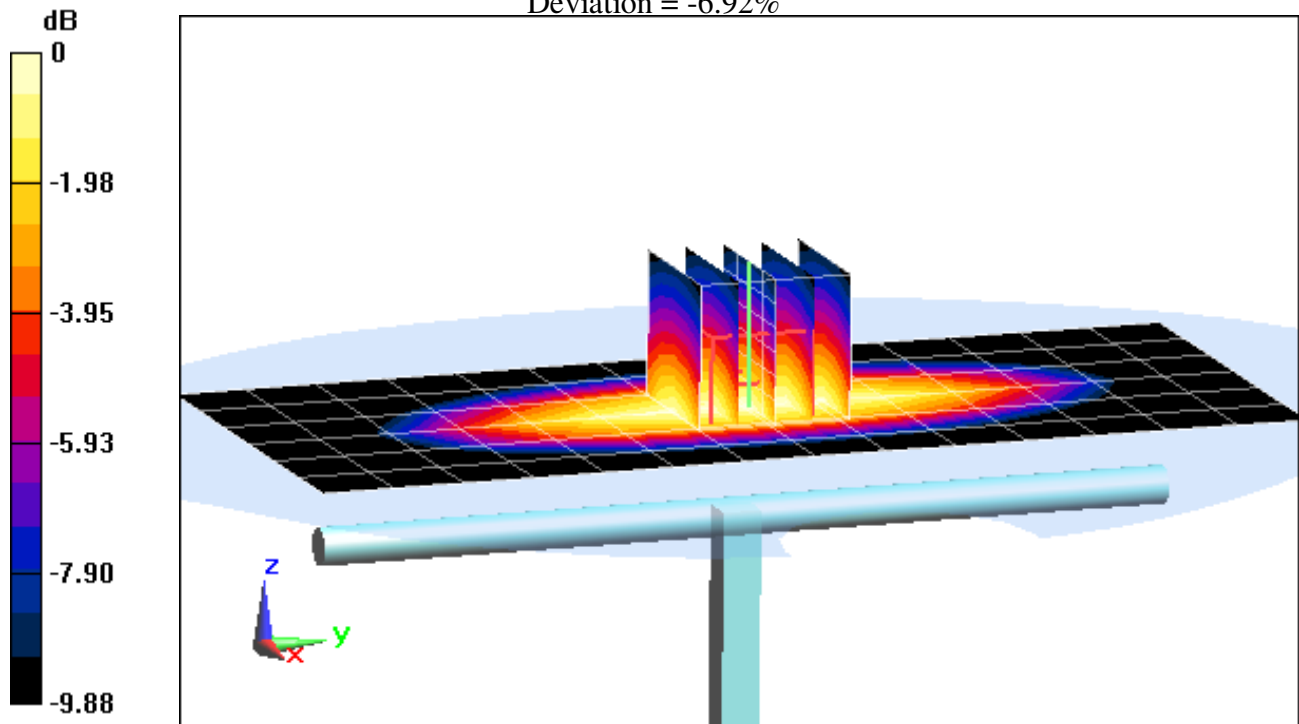

0 dB = 0.505 W/kg = -2.97 dBW/kg



# PCTEST ENGINEERING LABORATORY, INC.

**DUT: SAR Dipole 835 MHz; Type: D835V2; Serial: 4d132**

Communication System: CW; Frequency: 835 MHz; Duty Cycle: 1:1

Medium: 835 Body Medium parameters used:

$f = 835 \text{ MHz}$ ;  $\sigma = 0.993 \text{ S/m}$ ;  $\epsilon_r = 54.42$ ;  $\rho = 1000 \text{ kg/m}^3$

Phantom section: Flat Section; Space: 1.5 cm

Test Date: 12-10-2012; Ambient Temp: 21.9°C; Tissue Temp: 20.2°C

Probe: ES3DV3 - SN3263; ConvF(6.15, 6.15, 6.15); Calibrated: 5/18/2012;

Sensor-Surface: 4mm (Mechanical Surface Detection)

Electronics: DAE4 Sn1334; Calibrated: 5/7/2012

Phantom: SAM 5.0 front; Type: QD000P40CD; Serial: TP:-1648

Measurement SW: DASY52, Version 52.8 (3); SEMCAD X Version 14.6.8 (7028)

## 835 MHz System Verification

**Area Scan (7x14x1):** Measurement grid: dx=15mm, dy=15mm

**Zoom Scan (5x5x7)/Cube 0:** Measurement grid: dx=8mm, dy=8mm, dz=5mm

Input Power = 19.54 dBm (90 mW)

Peak SAR (extrapolated) = 1.31 W/kg

**SAR(1 g) = 0.907 W/kg; SAR(10 g) = 0.597 W/kg**

Deviation = 7.10%

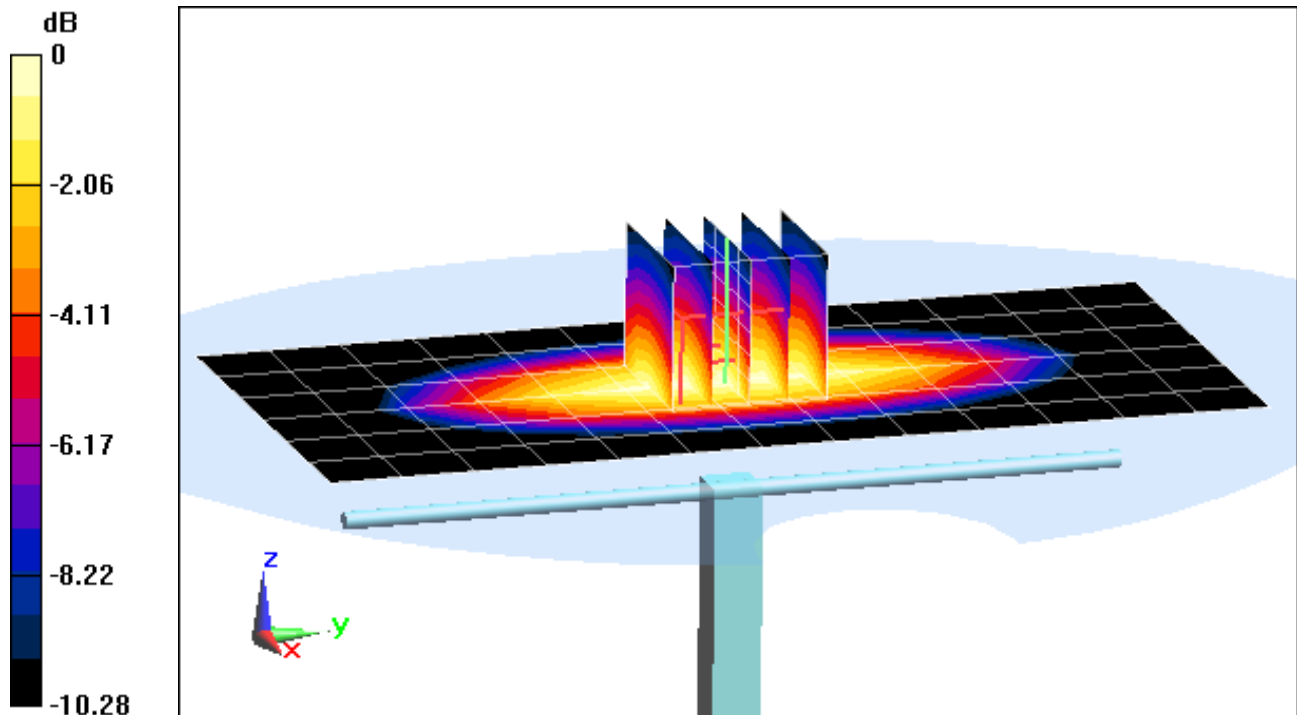

0 dB = 0.982 W/kg = -0.08 dBW/kg

# PCTEST ENGINEERING LABORATORY, INC.

**DUT: Dipole 835 MHz; Type: D835V2; Serial: 4d026**

Communication System: CW; Frequency: 835 MHz; Duty Cycle: 1:1

Medium: 835 Body Medium parameters used:

$f = 835 \text{ MHz}$ ;  $\sigma = 1.004 \text{ S/m}$ ;  $\epsilon_r = 53.085$ ;  $\rho = 1000 \text{ kg/m}^3$

Phantom section: Flat Section; Space: 1.5 cm

Test Date: 02-19-2013; Ambient Temp: 22.8°C; Tissue Temp: 22.2°C

Probe: ES3DV3 - SN3287; ConvF(6.06, 6.06, 6.06); Calibrated: 11/15/2012;

Sensor-Surface: 4mm (Mechanical Surface Detection)

Electronics: DAE4 Sn1333; Calibrated: 11/13/2012

Phantom: SAM with CRP; Type: SAM 4.0; Serial: TP1375

Measurement SW: DASY4, Version 4.7 (80); SEMCAD X Version 14.6.8 (7028)

## 835MHz System Verification

**Area Scan (7x13x1):** Measurement grid: dx=15mm, dy=15mm

**Zoom Scan (5x5x7)/Cube 0:** Measurement grid: dx=8mm, dy=8mm, dz=5mm

Input Power = 20 dBm (100 mW)

Peak SAR (extrapolated) = 1.48 W/kg

**SAR(1 g) = 1.02 W/kg; SAR(10 g) = 0.672 W/kg**

Deviation = 6.47%

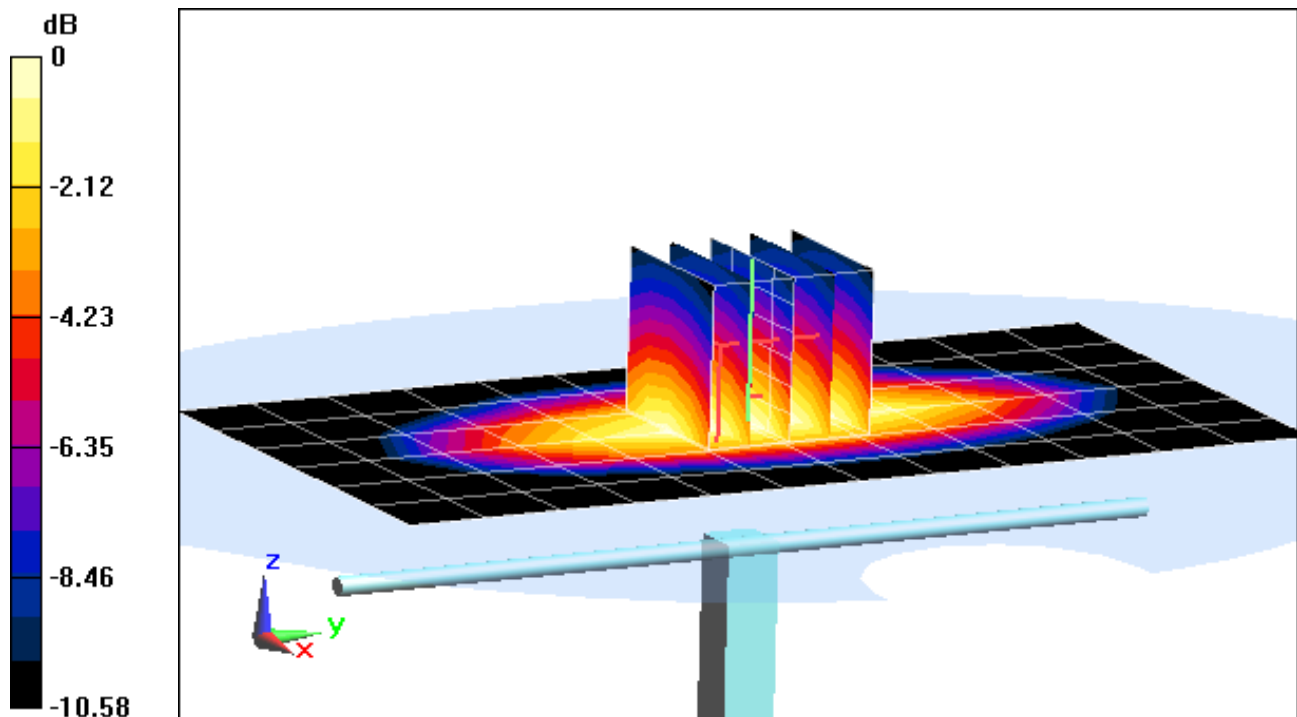

0 dB = 1.11 W/kg = 0.45 dBW/kg

# PCTEST ENGINEERING LABORATORY, INC.

**DUT: Dipole 1750 MHz; Type: D1750V2; Serial: 1051**

Communication System: CW; Frequency: 1750 MHz; Duty Cycle: 1:1

Medium: 1750 Body Medium parameters used:

$f = 1750 \text{ MHz}$ ;  $\sigma = 1.461 \text{ S/m}$ ;  $\epsilon_r = 52.3$ ;  $\rho = 1000 \text{ kg/m}^3$

Phantom section: Flat Section; Space: 1.0 cm

Test Date: 02-10-2013; Ambient Temp: 23.3°C; Tissue Temp: 22.3°C

Probe: ES3DV3 - SN3288; ConvF(5.18, 5.18, 5.18); Calibrated: 9/20/2012;

Sensor-Surface: 4mm (Mechanical Surface Detection)

Electronics: DAE4 Sn1323; Calibrated: 9/19/2012

Phantom: SAM v5.0 Left; Type: QD000P40CD; Serial: TP: 1687

Measurement SW: DASY52, Version 52.8 (5); SEMCAD X Version 14.6.8 (7028)

## 1750 MHz System Verification

**Area Scan (7x9x1):** Measurement grid: dx=15mm, dy=15mm

**Zoom Scan (5x5x7)/Cube 0:** Measurement grid: dx=8mm, dy=8mm, dz=5mm

Input Power = 20 dBm (100 mW)

Peak SAR (extrapolated) = 7.23 W/kg

**SAR(1 g) = 4.04 W/kg; SAR(10 g) = 2.13 W/kg**

Deviation = 7.45%

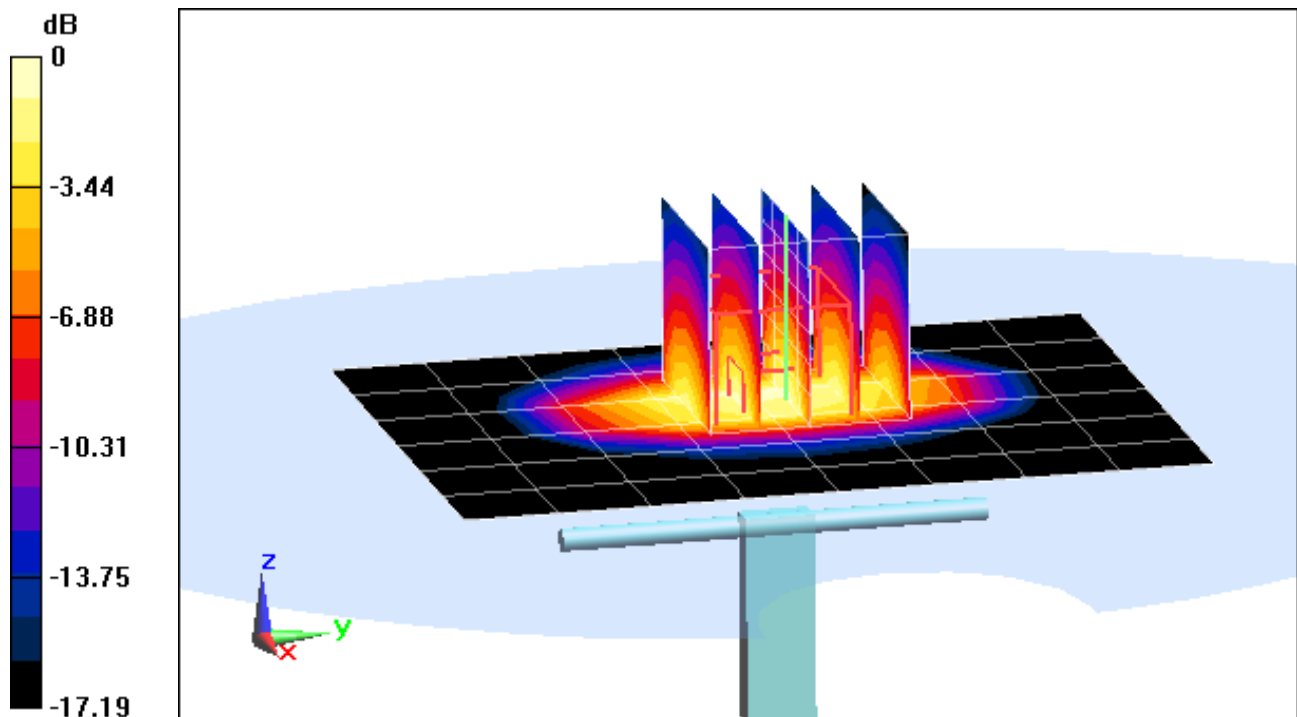

0 dB = 4.52 W/kg = 6.55 dBW/kg

# PCTEST ENGINEERING LABORATORY, INC.

**DUT: SAR Dipole 1900 MHz; Type: D1900V2; Serial: 5d149**

Communication System: CW; Frequency: 1900 MHz; Duty Cycle: 1:1

Medium: 1900 Body Medium parameters used (interpolated):

$f = 1900 \text{ MHz}$ ;  $\sigma = 1.559 \text{ S/m}$ ;  $\epsilon_r = 52.827$ ;  $\rho = 1000 \text{ kg/m}^3$

Phantom section: Flat Section; Space: 1.0 cm

Test Date: 02-07-2013; Ambient Temp: 23.4°C; Tissue Temp: 22.1°C

Probe: ES3DV3 - SN3263; ConvF(4.76, 4.76, 4.76); Calibrated: 5/18/2012;

Sensor-Surface: 4mm (Mechanical Surface Detection)

Electronics: DAE4 Sn1334; Calibrated: 5/7/2012

Phantom: SAM 5.0 front; Type: QD000P40CD; Serial: TP:-1648

Measurement SW: DASY52, Version 52.8 (5); SEMCAD X Version 14.6.8 (7028)

## 1900 MHz System Verification

**Area Scan (7x10x1):** Measurement grid: dx=15mm, dy=15mm

**Zoom Scan (5x5x7)/Cube 0:** Measurement grid: dx=8mm, dy=8mm, dz=5mm

Input Power = 20 dBm (100 mW)

Peak SAR (extrapolated) = 7.72 W/kg

**SAR(1 g) = 4.02 W/kg; SAR(10 g) = 2.23 W/kg**

Deviation = 2.29%

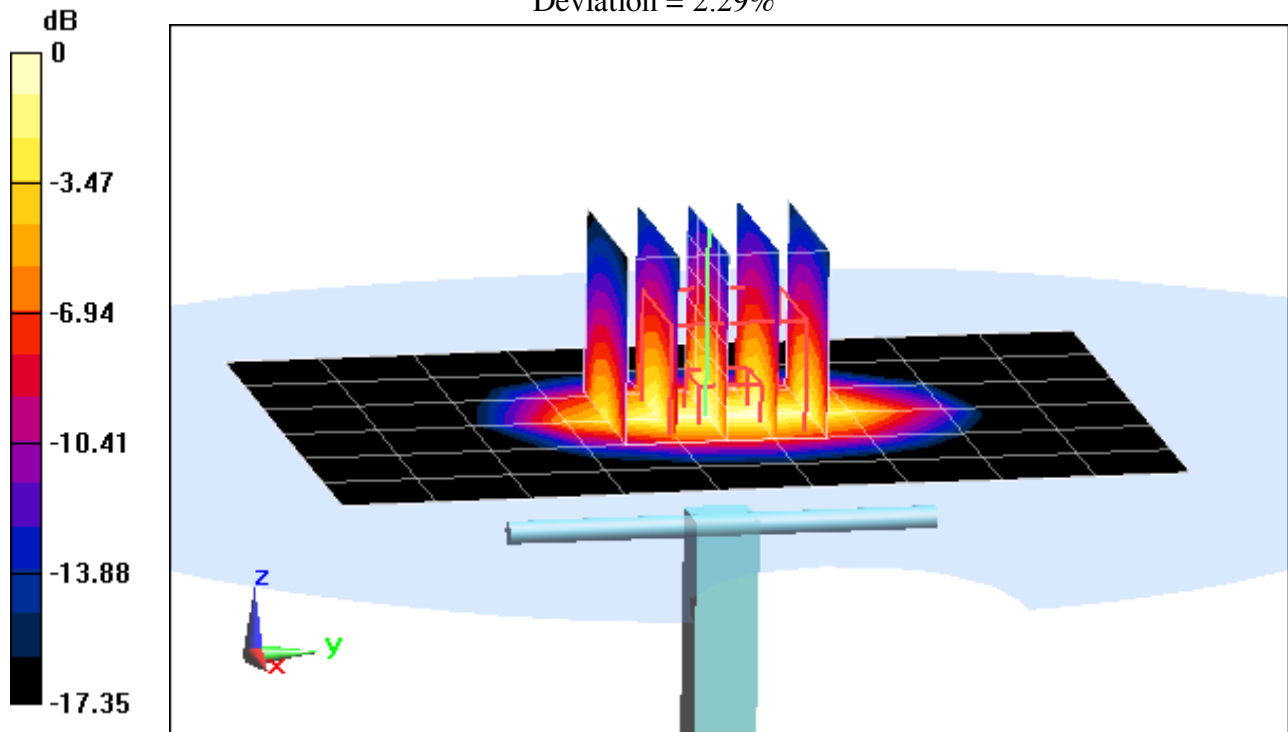

0 dB = 4.76 W/kg = 6.78 dBW/kg

# PCTEST ENGINEERING LABORATORY, INC.

**DUT: SAR Dipole 2450 MHz; Type: D2450V2; Serial: 719**

Communication System: CW; Frequency: 2450 MHz; Duty Cycle: 1:1

Medium: 2450 Body Medium parameters used:

$f = 2450 \text{ MHz}$ ;  $\sigma = 1.98 \text{ S/m}$ ;  $\epsilon_r = 50.66$ ;  $\rho = 1000 \text{ kg/m}^3$

Phantom section: Flat Section; Space: 1.0 cm

Test Date: 12-11-2012; Ambient Temp: 24.4°C; Tissue Temp: 23.3°C

Probe: ES3DV3 - SN3258; ConvF(4.28, 4.28, 4.28); Calibrated: 2/21/2012;

Sensor-Surface: 3mm (Mechanical Surface Detection)

Electronics: DAE4 Sn1272; Calibrated: 1/18/2012

Phantom: SAM Main; Type: SAM 4.0; Serial: TP-1114

Measurement SW: DASY4, Version 4.7 (80); SEMCAD X Version 14.6.8 (7028)

## 2450MHz System Verification

**Area Scan (6x8x1):** Measurement grid: dx=12mm, dy=12mm

**Zoom Scan (7x7x7)/Cube 0:** Measurement grid: dx=5mm, dy=5mm, dz=5mm

Input Power = 16 dBm (40 mW)

Peak SAR (extrapolated) = 4.82 W/kg

**SAR(1 g) = 2.22 W/kg; SAR(10 g) = 1.02 W/kg**

Deviation = 7.56%

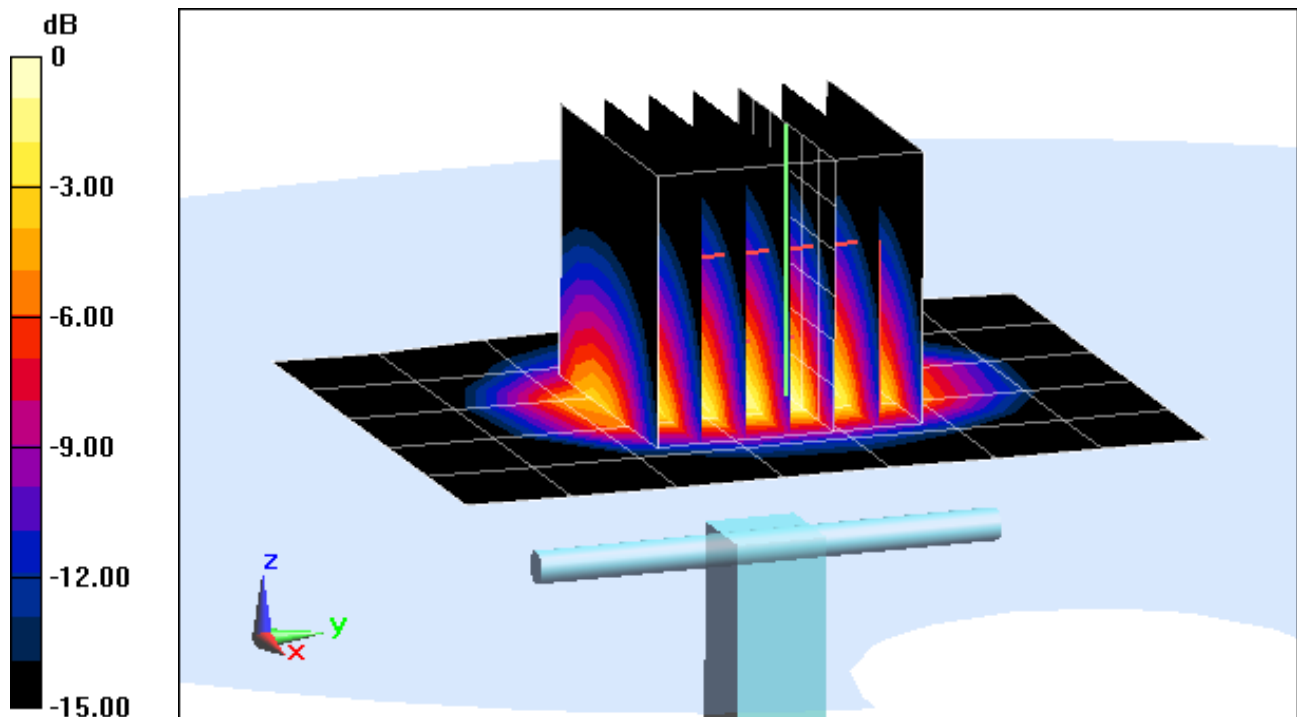

0 dB = 2.85 W/kg = 4.55 dBW/kg

## APPENDIX C: PROBE CALIBRATION



Accredited by the Swiss Accreditation Service (SAS)  
The Swiss Accreditation Service is one of the signatories to the EA  
Multilateral Agreement for the recognition of calibration certificates

Accreditation No.: **SCS 108**

Client **PC Test**

Certificate No: **D750V3-1054\_Feb12**

**CALIBRATION CERTIFICATE**

Object **D750V3 - SN: 1054**

Calibration procedure(s) **QA CAL-05.v8  
Calibration procedure for dipole validation kits above 700 MHz**

Calibration date: **February 09, 2012**

*✓  
KOK  
5/11/12*

This calibration certificate documents the traceability to national standards, which realize the physical units of measurements (SI).  
The measurements and the uncertainties with confidence probability are given on the following pages and are part of the certificate.

All calibrations have been conducted in the closed laboratory facility: environment temperature (22 ± 3)°C and humidity < 70%.

Calibration Equipment used (M&TE critical for calibration)

Primary Standards	ID #	Cal Date (Certificate No.)	Scheduled Calibration
Power meter EPM-442A	GB37480704	05-Oct-11 (No. 217-01451)	Oct-12
Power sensor HP 8481A	US37292783	05-Oct-11 (No. 217-01451)	Oct-12
Reference 20 dB Attenuator	SN: 5086 (20g)	29-Mar-11 (No. 217-01368)	Apr-12
Type-N mismatch combination	SN: 5047.2 / 06327	29-Mar-11 (No. 217-01371)	Apr-12
Reference Probe ES3DV3	SN: 3205	30-Dec-11 (No. ES3-3205_Dec11)	Dec-12
DAE4	SN: 601	04-Jul-11 (No. DAE4-601_Jul11)	Jul-12
Secondary Standards	ID #	Check Date (in house)	Scheduled Check
Power sensor HP 8481A	MY41092317	18-Oct-02 (in house check Oct-11)	In house check: Oct-13
RF generator R&S SMT-06	100005	04-Aug-99 (in house check Oct-11)	In house check: Oct-13
Network Analyzer HP 8753E	US37390585 S4206	18-Oct-01 (in house check Oct-11)	In house check: Oct-12

	Name	Function	Signature
Calibrated by:	Israe El-Naouq	Laboratory Technician	<i>Israe El-Naouq</i>
Approved by:	Katja Pokovic	Technical Manager	<i>Katja Pokovic</i>

Issued: February 9, 2012

This calibration certificate shall not be reproduced except in full without written approval of the laboratory.



Accredited by the Swiss Accreditation Service (SAS)

The Swiss Accreditation Service is one of the signatories to the EA  
Multilateral Agreement for the recognition of calibration certificates

Accreditation No.: **SCS 108**

### Glossary:

TSL	tissue simulating liquid
ConvF	sensitivity in TSL / NORM x,y,z
N/A	not applicable or not measured

### Calibration is Performed According to the Following Standards:

- IEEE Std 1528-2003, "IEEE Recommended Practice for Determining the Peak Spatial-Averaged Specific Absorption Rate (SAR) in the Human Head from Wireless Communications Devices: Measurement Techniques", December 2003
- IEC 62209-1, "Procedure to measure the Specific Absorption Rate (SAR) for hand-held devices used in close proximity to the ear (frequency range of 300 MHz to 3 GHz)", February 2005
- Federal Communications Commission Office of Engineering & Technology (FCC OET), "Evaluating Compliance with FCC Guidelines for Human Exposure to Radiofrequency Electromagnetic Fields; Additional Information for Evaluating Compliance of Mobile and Portable Devices with FCC Limits for Human Exposure to Radiofrequency Emissions", Supplement C (Edition 01-01) to Bulletin 65

### Additional Documentation:

- DASY4/5 System Handbook

### Methods Applied and Interpretation of Parameters:

- Measurement Conditions:** Further details are available from the Validation Report at the end of the certificate. All figures stated in the certificate are valid at the frequency indicated.
- Antenna Parameters with TSL:** The dipole is mounted with the spacer to position its feed point exactly below the center marking of the flat phantom section, with the arms oriented parallel to the body axis.
- Feed Point Impedance and Return Loss:** These parameters are measured with the dipole positioned under the liquid filled phantom. The impedance stated is transformed from the measurement at the SMA connector to the feed point. The Return Loss ensures low reflected power. No uncertainty required.
- Electrical Delay:** One-way delay between the SMA connector and the antenna feed point. No uncertainty required.
- SAR measured:** SAR measured at the stated antenna input power.
- SAR normalized:** SAR as measured, normalized to an input power of 1 W at the antenna connector.
- SAR for nominal TSL parameters:** The measured TSL parameters are used to calculate the nominal SAR result.



## Measurement Conditions

DASY system configuration, as far as not given on page 1.

DASY Version	DASY5	V52.8.0
Extrapolation	Advanced Extrapolation	
Phantom	Modular Flat Phantom	
Distance Dipole Center - TSL	15 mm	with Spacer
Zoom Scan Resolution	dx, dy, dz = 5 mm	
Frequency	750 MHz ± 1 MHz	

## Head TSL parameters

The following parameters and calculations were applied.

	Temperature	Permittivity	Conductivity
Nominal Head TSL parameters	22.0 °C	41.9	0.89 mho/m
Measured Head TSL parameters	(22.0 ± 0.2) °C	42.3 ± 6 %	0.92 mho/m ± 6 %
Head TSL temperature change during test	< 0.5 °C	----	----

## SAR result with Head TSL

SAR averaged over 1 cm <sup>3</sup> (1 g) of Head TSL	Condition	
SAR measured	250 mW input power	2.18 mW / g
SAR for nominal Head TSL parameters	normalized to 1W	<b>8.52 mW / g ± 17.0 % (k=2)</b>

SAR averaged over 10 cm <sup>3</sup> (10 g) of Head TSL	condition	
SAR measured	250 mW input power	1.42 mW / g
SAR for nominal Head TSL parameters	normalized to 1W	<b>5.57 mW / g ± 16.5 % (k=2)</b>

## Body TSL parameters

The following parameters and calculations were applied.

	Temperature	Permittivity	Conductivity
Nominal Body TSL parameters	22.0 °C	55.5	0.96 mho/m
Measured Body TSL parameters	(22.0 ± 0.2) °C	55.6 ± 6 %	0.96 mho/m ± 6 %
Body TSL temperature change during test	< 0.5 °C	----	----

## SAR result with Body TSL

SAR averaged over 1 cm <sup>3</sup> (1 g) of Body TSL	Condition	
SAR measured	250 mW input power	2.21 mW / g
SAR for nominal Body TSL parameters	normalized to 1W	<b>8.84 mW / g ± 17.0 % (k=2)</b>

SAR averaged over 10 cm <sup>3</sup> (10 g) of Body TSL	condition	
SAR measured	250 mW input power	1.46 mW / g
SAR for nominal Body TSL parameters	normalized to 1W	<b>5.84 mW / g ± 16.5 % (k=2)</b>

## Appendix

### Antenna Parameters with Head TSL

Impedance, transformed to feed point	54.0 $\Omega$ - 1.5 j $\Omega$
Return Loss	- 27.8 dB

### Antenna Parameters with Body TSL

Impedance, transformed to feed point	49.6 $\Omega$ - 3.4 j $\Omega$
Return Loss	- 29.2 dB

### General Antenna Parameters and Design

Electrical Delay (one direction)	1.041 ns
----------------------------------	----------

After long term use with 100W radiated power, only a slight warming of the dipole near the feedpoint can be measured.

The dipole is made of standard semirigid coaxial cable. The center conductor of the feeding line is directly connected to the second arm of the dipole. The antenna is therefore short-circuited for DC-signals. On some of the dipoles, small end caps are added to the dipole arms in order to improve matching when loaded according to the position as explained in the "Measurement Conditions" paragraph. The SAR data are not affected by this change. The overall dipole length is still according to the Standard.

No excessive force must be applied to the dipole arms, because they might bend or the soldered connections near the feedpoint may be damaged.

### Additional EUT Data

Manufactured by	SPEAG
Manufactured on	November 08, 2011

## DASY5 Validation Report for Head TSL

Date: 09.02.2012

Test Laboratory: SPEAG, Zurich, Switzerland

**DUT: Dipole 750 MHz; Type: D750V3; Serial: D750V3 - SN: 1054**

Communication System: CW; Frequency: 750 MHz

Medium parameters used:  $f = 750$  MHz;  $\sigma = 0.92$  mho/m;  $\epsilon_r = 42.3$ ;  $\rho = 1000$  kg/m<sup>3</sup>

Phantom section: Flat Section

Measurement Standard: DASY5 (IEEE/IEC/ANSI C63.19-2007)

DASY52 Configuration:

- Probe: ES3DV3 - SN3205; ConvF(6.33, 6.33, 6.33); Calibrated: 30.12.2011
- Sensor-Surface: 3mm (Mechanical Surface Detection)
- Electronics: DAE4 Sn601; Calibrated: 04.07.2011
- Phantom: Flat Phantom 4.9L; Type: QD000P49AA; Serial: 1001
- DASY52 52.8.0(692); SEMCAD X 14.6.4(4989)

**Dipole Calibration for Head Tissue/Pin=250mW, d=15mm/Zoom Scan (7x7x7)/Cube 0:**

Measurement grid: dx=5mm, dy=5mm, dz=5mm

Reference Value = 53.659 V/m; Power Drift = 0.02 dB

Peak SAR (extrapolated) = 3.2940

**SAR(1 g) = 2.18 mW/g; SAR(10 g) = 1.42 mW/g**

Maximum value of SAR (measured) = 2.552 mW/g

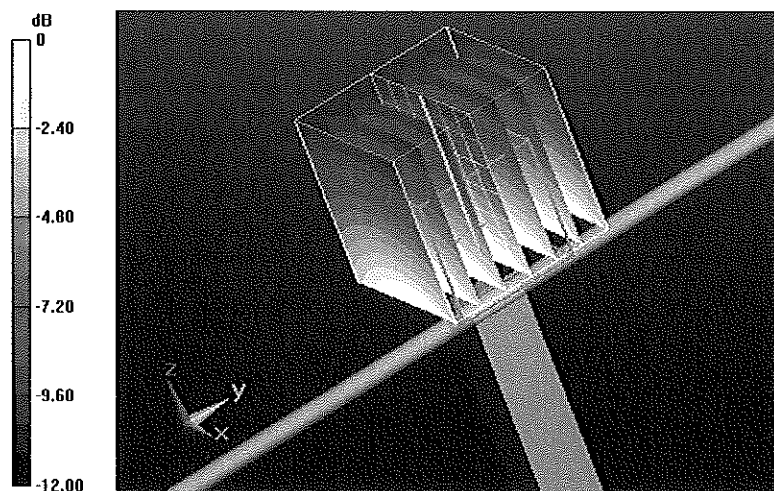

0 dB = 2.550mW/g = 8.13 dB mW/g

# Impedance Measurement Plot for Head TSL

9 Feb 2012 15:46:54  
[CH1] S11 1 U FS 1: 53.955  $\Omega$  -1.4746  $\Omega$  143.91 pF 750.000 000 MHz

\*  
De1  
Cor  
Avg  
0  
H1 d

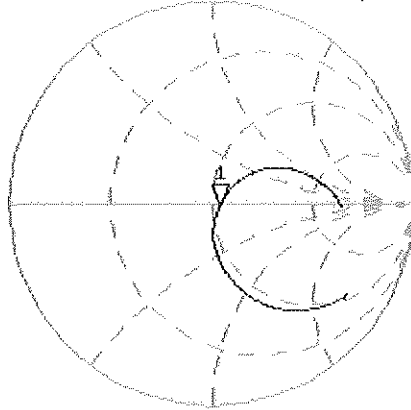

CH2 S11 LOG 5 dB/REF -20 dB 1:-27.835 dB 750.000 000 MHz

Cor  
Avg  
0  
H1 d

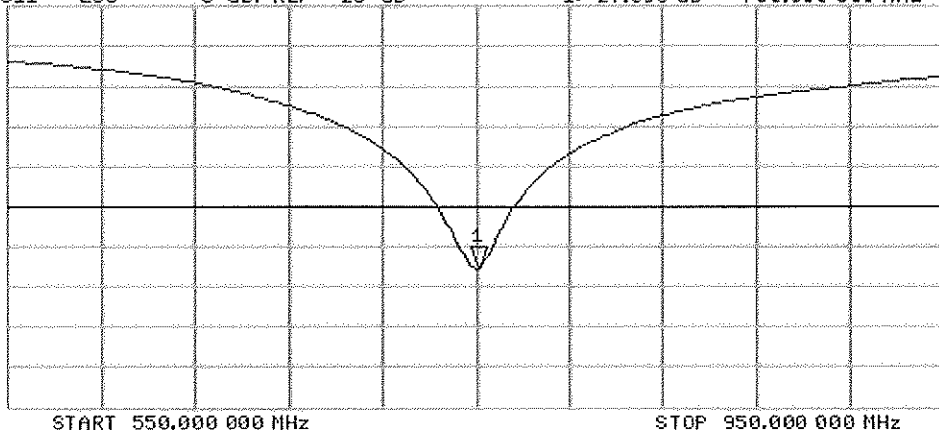

## DASY5 Validation Report for Body TSL

Date: 09.02.2012

Test Laboratory: SPEAG, Zurich, Switzerland

**DUT: Dipole 750 MHz; Type: D750V3; Serial: D750V3 - SN: 1054**

Communication System: CW; Frequency: 750 MHz

Medium parameters used:  $f = 750$  MHz;  $\sigma = 0.96$  mho/m;  $\epsilon_r = 55.6$ ;  $\rho = 1000$  kg/m<sup>3</sup>

Phantom section: Flat Section

Measurement Standard: DASY5 (IEEE/IEC/ANSI C63.19-2007)

DASY52 Configuration:

- Probe: ES3DV3 - SN3205; ConvF(6.12, 6.12, 6.12); Calibrated: 30.12.2011
- Sensor-Surface: 3mm (Mechanical Surface Detection)
- Electronics: DAE4 Sn601; Calibrated: 04.07.2011
- Phantom: Flat Phantom 4.9L; Type: QD000P49AA; Serial: 1001
- DASY52 52.8.0(692); SEMCAD X 14.6.4(4989)

### Dipole Calibration for Body Tissue/Pin=250mW, d=15mm/Zoom Scan (7x7x7)/Cube 0:

Measurement grid: dx=5mm, dy=5mm, dz=5mm

Reference Value = 53.016 V/m; Power Drift = 0.03 dB

Peak SAR (extrapolated) = 3.2860

**SAR(1 g) = 2.21 mW/g; SAR(10 g) = 1.46 mW/g**

Maximum value of SAR (measured) = 2.576 mW/g

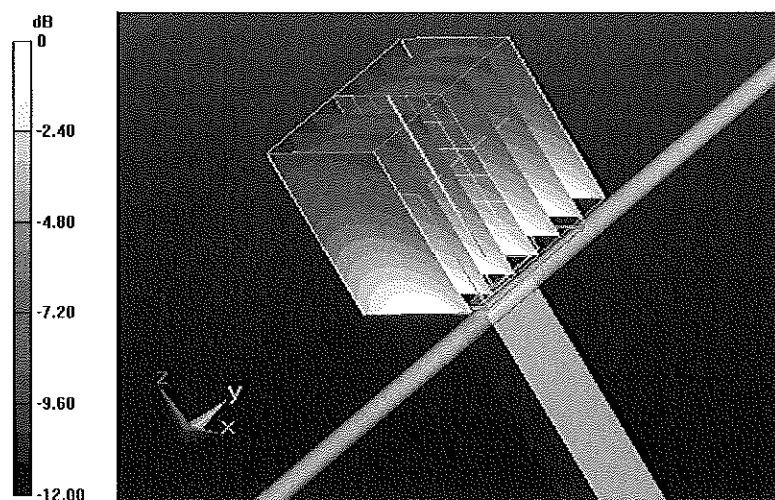

0 dB = 2.580mW/g = 8.23 dB mW/g

# Impedance Measurement Plot for Body TSL

9 Feb 2012 12:59:08  
[CH1] S11 1 U FS 1: 49.650  $\Omega$  -3.4414  $\Omega$  61.663 pF 750.000 000 MHz

\*  
De1  
Cor  
Avg  
16  
H1d

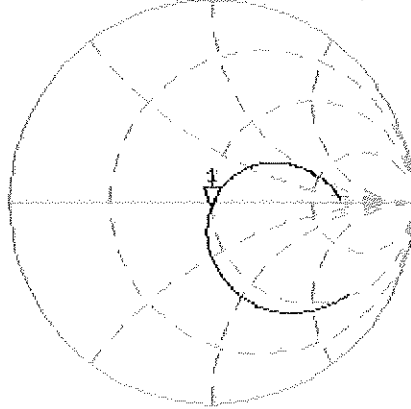

CH2 S11 LOG 5 dB/REF -20 dB 1:-29.187 dB 750.000 000 MHz

Cor  
Avg  
16  
H1d

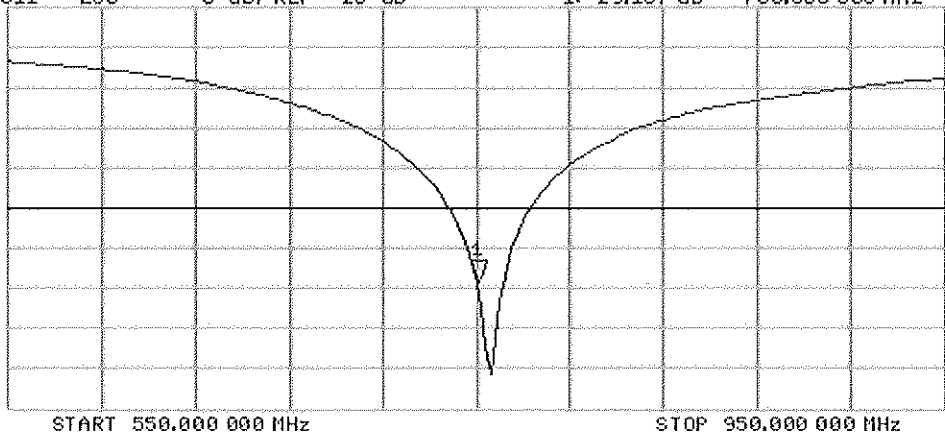

**Calibration Laboratory of  
Schmid & Partner  
Engineering AG**  
Zeughausstrasse 43, 8004 Zurich, Switzerland



**S** Schweizerischer Kalibrierdienst  
**C** Service suisse d'étalonnage  
**S** Servizio svizzero di taratura  
**S** Swiss Calibration Service

Accredited by the Swiss Accreditation Service (SAS)  
The Swiss Accreditation Service is one of the signatories to the EA  
Multilateral Agreement for the recognition of calibration certificates

Accreditation No.: **SCS 108**

Client **PC Test**

Certificate No: **D835V2-4d026\_Aug12**

## CALIBRATION CERTIFICATE

Object **D835V2 - SN: 4d026**

Calibration procedure(s) **QA CAL-05.v8  
Calibration procedure for dipole validation kits above 700 MHz**

Calibration date: **August 23, 2012**

*1/10K  
9/17/12*

This calibration certificate documents the traceability to national standards, which realize the physical units of measurements (SI).  
The measurements and the uncertainties with confidence probability are given on the following pages and are part of the certificate.

All calibrations have been conducted in the closed laboratory facility: environment temperature (22 ± 3)°C and humidity < 70%.

Calibration Equipment used (M&TE critical for calibration)

Primary Standards	ID #	Cal Date (Certificate No.)	Scheduled Calibration
Power meter EPM-442A	GB37480704	05-Oct-11 (No. 217-01451)	Oct-12
Power sensor HP 8481A	US37292783	05-Oct-11 (No. 217-01451)	Oct-12
Reference 20 dB Attenuator	SN: 5058 (20k)	27-Mar-12 (No. 217-01530)	Apr-13
Type-N mismatch combination	SN: 5047.2 / 06327	27-Mar-12 (No. 217-01533)	Apr-13
Reference Probe ES3DV3	SN: 3205	30-Dec-11 (No. ES3-3205_Dec11)	Dec-12
DAE4	SN: 601	27-Jun-12 (No. DAE4-601_Jun12)	Jun-13
Secondary Standards	ID #	Check Date (in house)	Scheduled Check
Power sensor HP 8481A	MY41092317	18-Oct-02 (in house check Oct-11)	In house check: Oct-13
RF generator R&S SMT-06	100005	04-Aug-99 (in house check Oct-11)	In house check: Oct-13
Network Analyzer HP 8753E	US37390585 S4206	18-Oct-01 (in house check Oct-11)	In house check: Oct-12

Calibrated by: **Israe El-Naouq**      Name: **Israe El-Naouq**      Function: **Laboratory Technician**

Approved by: **Katja Pokovic**      Name: **Katja Pokovic**      Function: **Technical Manager**

Signature  
*Israe El-Naouq*  
*Katja Pokovic*

Issued: August 23, 2012

This calibration certificate shall not be reproduced except in full without written approval of the laboratory.

**Calibration Laboratory of  
Schmid & Partner  
Engineering AG**  
Zeughausstrasse 43, 8004 Zurich, Switzerland



**S** Schweizerischer Kalibrierdienst  
**C** Service suisse d'étalonnage  
**S** Servizio svizzero di taratura  
**S** Swiss Calibration Service

Accredited by the Swiss Accreditation Service (SAS)  
The Swiss Accreditation Service is one of the signatories to the EA  
Multilateral Agreement for the recognition of calibration certificates

Accreditation No.: **SCS 108**

### Glossary:

TSL	tissue simulating liquid
ConvF	sensitivity in TSL / NORM x,y,z
N/A	not applicable or not measured

### Calibration is Performed According to the Following Standards:

- IEEE Std 1528-2003, "IEEE Recommended Practice for Determining the Peak Spatial-Averaged Specific Absorption Rate (SAR) in the Human Head from Wireless Communications Devices: Measurement Techniques", December 2003
- IEC 62209-1, "Procedure to measure the Specific Absorption Rate (SAR) for hand-held devices used in close proximity to the ear (frequency range of 300 MHz to 3 GHz)", February 2005
- Federal Communications Commission Office of Engineering & Technology (FCC OET), "Evaluating Compliance with FCC Guidelines for Human Exposure to Radiofrequency Electromagnetic Fields; Additional Information for Evaluating Compliance of Mobile and Portable Devices with FCC Limits for Human Exposure to Radiofrequency Emissions", Supplement C (Edition 01-01) to Bulletin 65

### Additional Documentation:

- DASY4/5 System Handbook

### Methods Applied and Interpretation of Parameters:

- Measurement Conditions:** Further details are available from the Validation Report at the end of the certificate. All figures stated in the certificate are valid at the frequency indicated.
- Antenna Parameters with TSL:** The dipole is mounted with the spacer to position its feed point exactly below the center marking of the flat phantom section, with the arms oriented parallel to the body axis.
- Feed Point Impedance and Return Loss:** These parameters are measured with the dipole positioned under the liquid filled phantom. The impedance stated is transformed from the measurement at the SMA connector to the feed point. The Return Loss ensures low reflected power. No uncertainty required.
- Electrical Delay:** One-way delay between the SMA connector and the antenna feed point. No uncertainty required.
- SAR measured:** SAR measured at the stated antenna input power.
- SAR normalized:** SAR as measured, normalized to an input power of 1 W at the antenna connector.
- SAR for nominal TSL parameters:** The measured TSL parameters are used to calculate the nominal SAR result.

The reported uncertainty of measurement is stated as the standard uncertainty of measurement multiplied by the coverage factor  $k=2$ , which for a normal distribution corresponds to a coverage probability of approximately 95%.



## Measurement Conditions

DASY system configuration, as far as not given on page 1.

DASY Version	DASY5	V52.8.2
Extrapolation	Advanced Extrapolation	
Phantom	Modular Flat Phantom	
Distance Dipole Center - TSL	15 mm	with Spacer
Zoom Scan Resolution	dx, dy, dz = 5 mm	
Frequency	835 MHz $\pm$ 1 MHz	

## Head TSL parameters

The following parameters and calculations were applied.

	Temperature	Permittivity	Conductivity
Nominal Head TSL parameters	22.0 °C	41.5	0.90 mho/m
Measured Head TSL parameters	(22.0 $\pm$ 0.2) °C	41.3 $\pm$ 6 %	0.90 mho/m $\pm$ 6 %
Head TSL temperature change during test	< 0.5 °C	---	---

## SAR result with Head TSL

SAR averaged over 1 cm <sup>3</sup> (1 g) of Head TSL	Condition	
SAR measured	250 mW input power	2.35 mW / g
SAR for nominal Head TSL parameters	normalized to 1W	<b>9.39 mW / g <math>\pm</math> 17.0 % (k=2)</b>

SAR averaged over 10 cm <sup>3</sup> (10 g) of Head TSL	condition	
SAR measured	250 mW input power	1.53 mW / g
SAR for nominal Head TSL parameters	normalized to 1W	<b>6.12 mW / g <math>\pm</math> 16.5 % (k=2)</b>

## Body TSL parameters

The following parameters and calculations were applied.

	Temperature	Permittivity	Conductivity
Nominal Body TSL parameters	22.0 °C	55.2	0.97 mho/m
Measured Body TSL parameters	(22.0 $\pm$ 0.2) °C	53.2 $\pm$ 6 %	1.00 mho/m $\pm$ 6 %
Body TSL temperature change during test	< 0.5 °C	---	---

## SAR result with Body TSL

SAR averaged over 1 cm <sup>3</sup> (1 g) of Body TSL	Condition	
SAR measured	250 mW input power	2.47 mW / g
SAR for nominal Body TSL parameters	normalized to 1W	<b>9.58 mW / g <math>\pm</math> 17.0 % (k=2)</b>

SAR averaged over 10 cm <sup>3</sup> (10 g) of Body TSL	condition	
SAR measured	250 mW input power	1.62 mW / g
SAR for nominal Body TSL parameters	normalized to 1W	<b>6.33 mW / g <math>\pm</math> 16.5 % (k=2)</b>

## Appendix

### Antenna Parameters with Head TSL

Impedance, transformed to feed point	53.7 $\Omega$ - 3.4 j $\Omega$
Return Loss	- 26.4 dB

### Antenna Parameters with Body TSL

Impedance, transformed to feed point	49.6 $\Omega$ - 4.8 j $\Omega$
Return Loss	- 26.4 dB

### General Antenna Parameters and Design

Electrical Delay (one direction)	1.389 ns
----------------------------------	----------

After long term use with 100W radiated power, only a slight warming of the dipole near the feedpoint can be measured.

The dipole is made of standard semirigid coaxial cable. The center conductor of the feeding line is directly connected to the second arm of the dipole. The antenna is therefore short-circuited for DC-signals. On some of the dipoles, small end caps are added to the dipole arms in order to improve matching when loaded according to the position as explained in the "Measurement Conditions" paragraph. The SAR data are not affected by this change. The overall dipole length is still according to the Standard.

No excessive force must be applied to the dipole arms, because they might bend or the soldered connections near the feedpoint may be damaged.

### Additional EUT Data

Manufactured by	SPEAG
Manufactured on	December 17, 2004

# DASY5 Validation Report for Head TSL

Date: 23.08.2012

Test Laboratory: SPEAG, Zurich, Switzerland

**DUT: Dipole 835 MHz; Type: D835V2; Serial: D835V2 - SN: 4d026**

Communication System: CW; Frequency: 835 MHz

Medium parameters used:  $f = 835$  MHz;  $\sigma = 0.9$  mho/m;  $\epsilon_r = 41.3$ ;  $\rho = 1000$  kg/m<sup>3</sup>

Phantom section: Flat Section

Measurement Standard: DASY5 (IEEE/IEC/ANSI C63.19-2007)

DASY52 Configuration:

- Probe: ES3DV3 - SN3205; ConvF(6.07, 6.07, 6.07); Calibrated: 30.12.2011;
- Sensor-Surface: 3mm (Mechanical Surface Detection)
- Electronics: DAE4 Sn601; Calibrated: 27.06.2012
- Phantom: Flat Phantom 4.9L; Type: QD000P49AA; Serial: 1001
- DASY52 52.8.2(969); SEMCAD X 14.6.6(6824)

## Dipole Calibration for Head Tissue/Pin=250 mW, d=15mm 2/Zoom Scan (7x7x7)/Cube 0:

Measurement grid: dx=5mm, dy=5mm, dz=5mm

Reference Value = 56.824 V/m; Power Drift = 0.01 dB

Peak SAR (extrapolated) = 3.482 mW/g

**SAR(1 g) = 2.35 mW/g; SAR(10 g) = 1.53 mW/g**

Maximum value of SAR (measured) = 2.72 W/kg

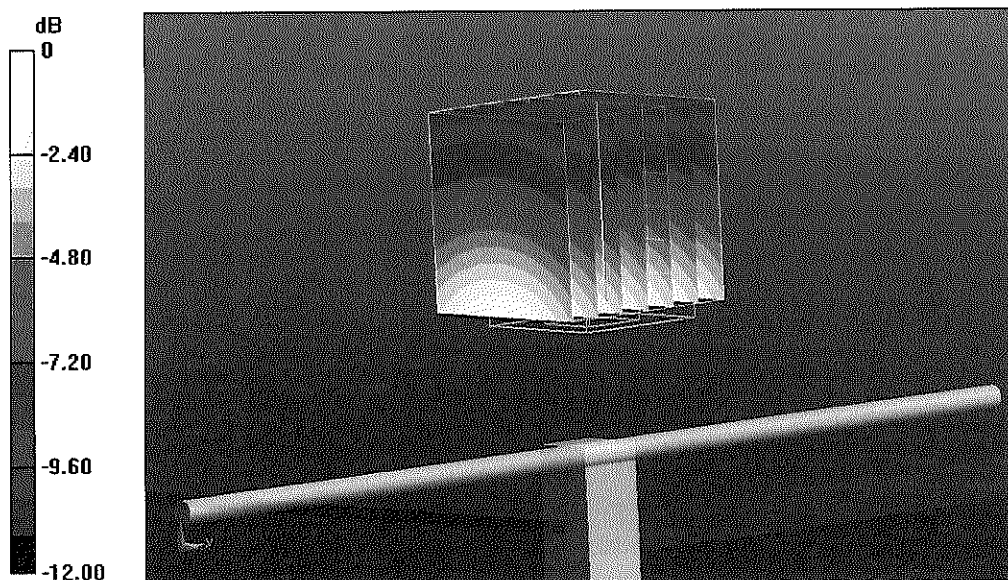

0 dB = 2.72 W/kg = 8.69 dB W/kg

# Impedance Measurement Plot for Head TSL

23 Aug 2012 12:19:04

[CH1] S11 1 U FS

1: 53.662  $\Delta$  -3.3516  $\Delta$  56.870 pF

835.000 000 MHz

\*

De1

Cor

Avg  
16

H1d

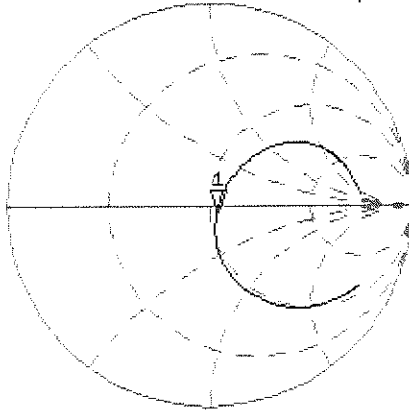

CH2 S11 LOG 5 dB/REF -20 dB 1:-25.390 dB 835.000 000 MHz

Cor

Avg  
16

H1d

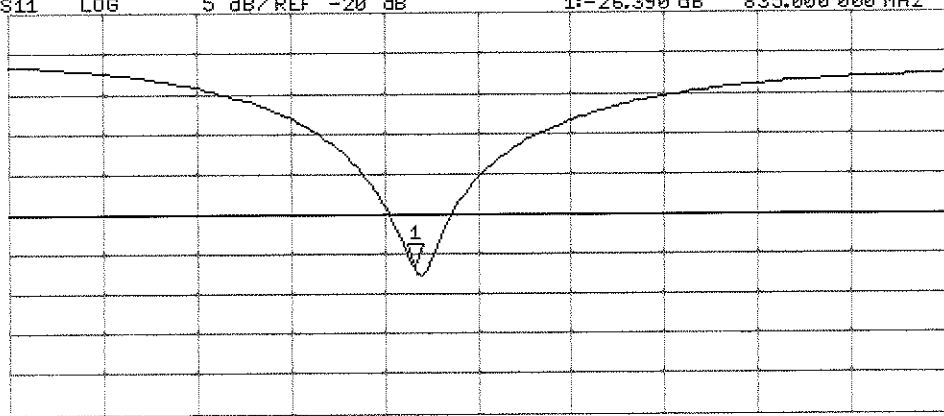

START 635.000 000 MHz

STOP 1 100.000 000 MHz

## DASY5 Validation Report for Body TSL

Date: 23.08.2012

Test Laboratory: SPEAG, Zurich, Switzerland

**DUT: Dipole 835 MHz; Type: D835V2; Serial: D835V2 - SN: 4d026**

Communication System: CW; Frequency: 835 MHz

Medium parameters used:  $f = 835$  MHz;  $\sigma = 1$  mho/m;  $\epsilon_r = 53.2$ ;  $\rho = 1000$  kg/m<sup>3</sup>

Phantom section: Flat Section

Measurement Standard: DASY5 (IEEE/IEC/ANSI C63.19-2007)

DASY52 Configuration:

- Probe: ES3DV3 - SN3205; ConvF(6.02, 6.02, 6.02); Calibrated: 30.12.2011;
- Sensor-Surface: 3mm (Mechanical Surface Detection)
- Electronics: DAE4 Sn601; Calibrated: 27.06.2012
- Phantom: Flat Phantom 4.9L; Type: QD000P49AA; Serial: 1001
- DASY52 52.8.2(969); SEMCAD X 14.6.6(6824)

### Dipole Calibration for Body Tissue/Pin=250 mW, d=15mm/Zoom Scan (7x7x7)/Cube 0:

Measurement grid: dx=5mm, dy=5mm, dz=5mm

Reference Value = 55.339 V/m; Power Drift = 0.04 dB

Peak SAR (extrapolated) = 3.592 mW/g

**SAR(1 g) = 2.47 mW/g; SAR(10 g) = 1.62 mW/g**

Maximum value of SAR (measured) = 2.87 W/kg

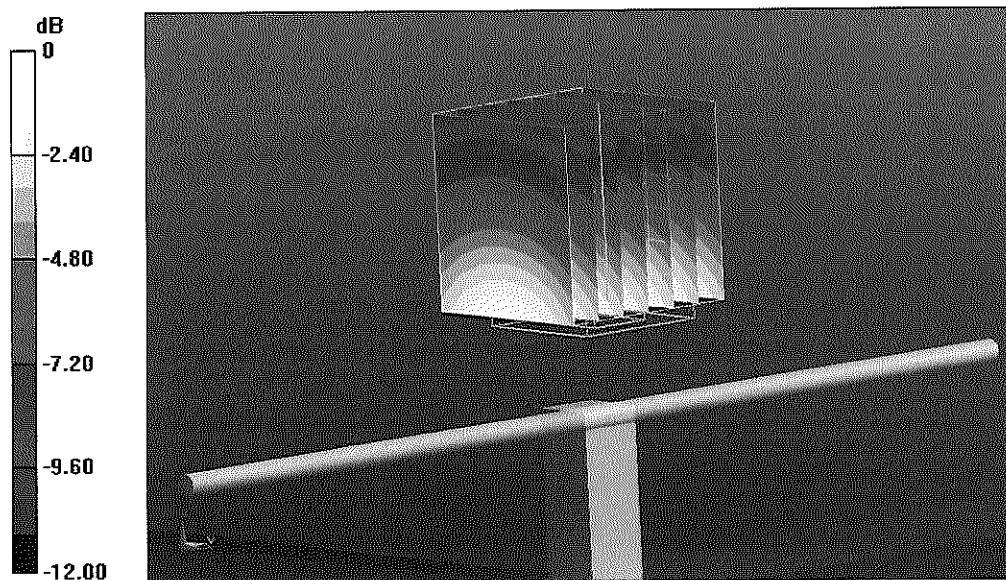

0 dB = 2.87 W/kg = 9.16 dB W/kg

# Impedance Measurement Plot for Body TSL

23 Aug 2012 10:54:42

[CH1] S11 1 U FS

1: 49.557  $\Delta$  -4.7500  $\Delta$  40.127 pF

835.000 000 MHz

\*  
Del  
Cor

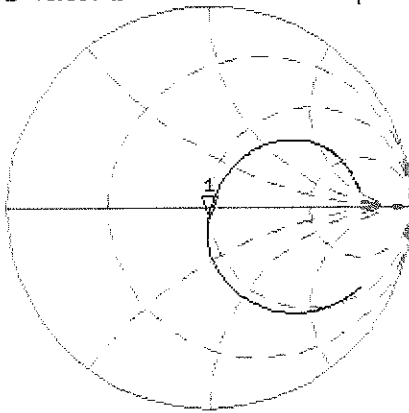

Avg  
16

H1 d

CH2 S11 LOG 5 dB/REF -20 dB 1: -26.405 dB 835.000 000 MHz

Cor

Avg  
16

H1 d

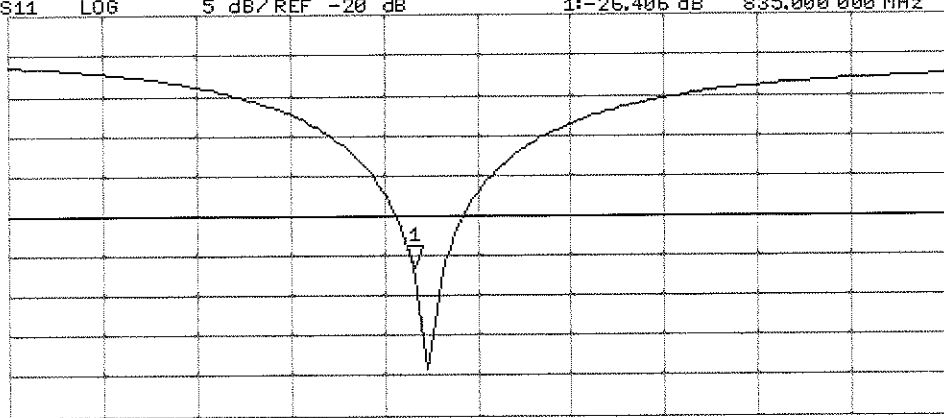

START 635.000 000 MHz

STOP 1 100.000 000 MHz



Accredited by the Swiss Accreditation Service (SAS)  
The Swiss Accreditation Service is one of the signatories to the EA  
Multilateral Agreement for the recognition of calibration certificates

Accreditation No.: **SCS 108**

Client **PC Test**

Certificate No: **D835V2-4d119\_Apr12**

**CALIBRATION CERTIFICATE**

Object **D835V2 - SN: 4d119**

Calibration procedure(s) **QA CAL-05.v8  
Calibration procedure for dipole validation kits above 700 MHz**

Calibration date: **April 20, 2012**

*✓ KOK  
5/4/12*

This calibration certificate documents the traceability to national standards, which realize the physical units of measurements (SI).  
The measurements and the uncertainties with confidence probability are given on the following pages and are part of the certificate.

All calibrations have been conducted in the closed laboratory facility: environment temperature (22 ± 3)°C and humidity < 70%.

Calibration Equipment used (M&TE critical for calibration)

Primary Standards	ID #	Cal Date (Certificate No.)	Scheduled Calibration
Power meter EPM-442A	GB37480704	05-Oct-11 (No. 217-01451)	Oct-12
Power sensor HP 8481A	US37292783	05-Oct-11 (No. 217-01451)	Oct-12
Reference 20 dB Attenuator	SN: 5058 (20k)	27-Mar-12 (No. 217-01530)	Apr-13
Type-N mismatch combination	SN: 5047.2 / 06327	27-Mar-12 (No. 217-01533)	Apr-13
Reference Probe ES3DV3	SN: 3205	30-Dec-11 (No. ES3-3205_Dec11)	Dec-12
DAE4	SN: 601	04-Jul-11 (No. DAE4-601_Jul11)	Jul-12
Secondary Standards	ID #	Check Date (in house)	Scheduled Check
Power sensor HP 8481A	MY41092317	18-Oct-02 (in house check Oct-11)	In house check: Oct-13
RF generator R&S SMT-06	100005	04-Aug-99 (in house check Oct-11)	In house check: Oct-13
Network Analyzer HP 8753E	US37390585 S4206	18-Oct-01 (in house check Oct-11)	In house check: Oct-12

Calibrated by:	<b>Israe El-Naouq</b>	<b>Laboratory Technician</b>	<i>Israe El-Naouq</i>
Approved by:	<b>Katja Pokovic</b>	<b>Technical Manager</b>	<i>Katja Pokovic</i>

Issued: April 20, 2012

This calibration certificate shall not be reproduced except in full without written approval of the laboratory.



Accredited by the Swiss Accreditation Service (SAS)  
The Swiss Accreditation Service is one of the signatories to the EA  
Multilateral Agreement for the recognition of calibration certificates

Accreditation No.: **SCS 108**

### Glossary:

TSL	tissue simulating liquid
ConvF	sensitivity in TSL / NORM x,y,z
N/A	not applicable or not measured

### Calibration is Performed According to the Following Standards:

- IEEE Std 1528-2003, "IEEE Recommended Practice for Determining the Peak Spatial-Averaged Specific Absorption Rate (SAR) in the Human Head from Wireless Communications Devices: Measurement Techniques", December 2003
- IEC 62209-1, "Procedure to measure the Specific Absorption Rate (SAR) for hand-held devices used in close proximity to the ear (frequency range of 300 MHz to 3 GHz)", February 2005
- Federal Communications Commission Office of Engineering & Technology (FCC OET), "Evaluating Compliance with FCC Guidelines for Human Exposure to Radiofrequency Electromagnetic Fields; Additional Information for Evaluating Compliance of Mobile and Portable Devices with FCC Limits for Human Exposure to Radiofrequency Emissions", Supplement C (Edition 01-01) to Bulletin 65

### Additional Documentation:

- DASY4/5 System Handbook

### Methods Applied and Interpretation of Parameters:

- Measurement Conditions:** Further details are available from the Validation Report at the end of the certificate. All figures stated in the certificate are valid at the frequency indicated.
- Antenna Parameters with TSL:** The dipole is mounted with the spacer to position its feed point exactly below the center marking of the flat phantom section, with the arms oriented parallel to the body axis.
- Feed Point Impedance and Return Loss:** These parameters are measured with the dipole positioned under the liquid filled phantom. The impedance stated is transformed from the measurement at the SMA connector to the feed point. The Return Loss ensures low reflected power. No uncertainty required.
- Electrical Delay:** One-way delay between the SMA connector and the antenna feed point. No uncertainty required.
- SAR measured:** SAR measured at the stated antenna input power.
- SAR normalized:** SAR as measured, normalized to an input power of 1 W at the antenna connector.
- SAR for nominal TSL parameters:** The measured TSL parameters are used to calculate the nominal SAR result.

The reported uncertainty of measurement is stated as the standard uncertainty of measurement multiplied by the coverage factor  $k=2$ , which for a normal distribution corresponds to a coverage probability of approximately 95%.



## Measurement Conditions

DASY system configuration, as far as not given on page 1.

DASY Version	DASY5	V52.8.1
Extrapolation	Advanced Extrapolation	
Phantom	Modular Flat Phantom	
Distance Dipole Center - TSL	15 mm	with Spacer
Zoom Scan Resolution	dx, dy, dz = 5 mm	
Frequency	835 MHz $\pm$ 1 MHz	

## Head TSL parameters

The following parameters and calculations were applied.

	Temperature	Permittivity	Conductivity
Nominal Head TSL parameters	22.0 °C	41.5	0.90 mho/m
Measured Head TSL parameters	(22.0 $\pm$ 0.2) °C	41.1 $\pm$ 6 %	0.90 mho/m $\pm$ 6 %
Head TSL temperature change during test	< 0.5 °C	----	----

## SAR result with Head TSL

SAR averaged over 1 cm <sup>3</sup> (1 g) of Head TSL	Condition	
SAR measured	250 mW input power	2.36 mW / g
SAR for nominal Head TSL parameters	normalized to 1W	<b>9.42 mW / g <math>\pm</math> 17.0 % (k=2)</b>

SAR averaged over 10 cm <sup>3</sup> (10 g) of Head TSL	condition	
SAR measured	250 mW input power	1.55 mW / g
SAR for nominal Head TSL parameters	normalized to 1W	<b>6.19 mW / g <math>\pm</math> 16.5 % (k=2)</b>

## Body TSL parameters

The following parameters and calculations were applied.

	Temperature	Permittivity	Conductivity
Nominal Body TSL parameters	22.0 °C	55.2	0.97 mho/m
Measured Body TSL parameters	(22.0 $\pm$ 0.2) °C	54.5 $\pm$ 6 %	1.01 mho/m $\pm$ 6 %
Body TSL temperature change during test	< 0.5 °C	----	----

## SAR result with Body TSL

SAR averaged over 1 cm <sup>3</sup> (1 g) of Body TSL	Condition	
SAR measured	250 mW input power	2.47 mW / g
SAR for nominal Body TSL parameters	normalized to 1W	<b>9.56 mW / g <math>\pm</math> 17.0 % (k=2)</b>

SAR averaged over 10 cm <sup>3</sup> (10 g) of Body TSL	condition	
SAR measured	250 mW input power	1.62 mW / g
SAR for nominal Body TSL parameters	normalized to 1W	<b>6.31 mW / g <math>\pm</math> 16.5 % (k=2)</b>

## Appendix

### Antenna Parameters with Head TSL

Impedance, transformed to feed point	51.3 $\Omega$ - 2.2 j $\Omega$
Return Loss	- 32.1 dB

### Antenna Parameters with Body TSL

Impedance, transformed to feed point	46.8 $\Omega$ - 4.3 j $\Omega$
Return Loss	- 25.2 dB

### General Antenna Parameters and Design

Electrical Delay (one direction)	1.386 ns
----------------------------------	----------

After long term use with 100W radiated power, only a slight warming of the dipole near the feedpoint can be measured.

The dipole is made of standard semirigid coaxial cable. The center conductor of the feeding line is directly connected to the second arm of the dipole. The antenna is therefore short-circuited for DC-signals. On some of the dipoles, small end caps are added to the dipole arms in order to improve matching when loaded according to the position as explained in the "Measurement Conditions" paragraph. The SAR data are not affected by this change. The overall dipole length is still according to the Standard.

No excessive force must be applied to the dipole arms, because they might bend or the soldered connections near the feedpoint may be damaged.

### Additional EUT Data

Manufactured by	SPEAG
Manufactured on	June 29, 2010

## DASY5 Validation Report for Head TSL

Date: 20.04.2012

Test Laboratory: SPEAG, Zurich, Switzerland

**DUT: Dipole 835 MHz; Type: D835V2; Serial: D835V2 - SN: 4d119**

Communication System: CW; Frequency: 835 MHz

Medium parameters used:  $f = 835$  MHz;  $\sigma = 0.9$  mho/m;  $\epsilon_r = 41.1$ ;  $\rho = 1000$  kg/m<sup>3</sup>

Phantom section: Flat Section

Measurement Standard: DASY5 (IEEE/IEC/ANSI C63.19-2007)

DASY52 Configuration:

- Probe: ES3DV3 - SN3205; ConvF(6.07, 6.07, 6.07); Calibrated: 30.12.2011;
- Sensor-Surface: 3mm (Mechanical Surface Detection)
- Electronics: DAE4 Sn601; Calibrated: 04.07.2011
- Phantom: Flat Phantom 4.9L; Type: QD000P49AA; Serial: 1001
- DASY52 52.8.1(838); SEMCAD X 14.6.5(6469)

### **Dipole Calibration for Head Tissue/Pin=250 mW, d=15mm/Zoom Scan (7x7x7)/Cube 0:**

Measurement grid: dx=5mm, dy=5mm, dz=5mm

Reference Value = 57.041 V/m; Power Drift = 0.04 dB

Peak SAR (extrapolated) = 3.480 mW/g

**SAR(1 g) = 2.36 mW/g; SAR(10 g) = 1.55 mW/g**

Maximum value of SAR (measured) = 2.75 mW/g

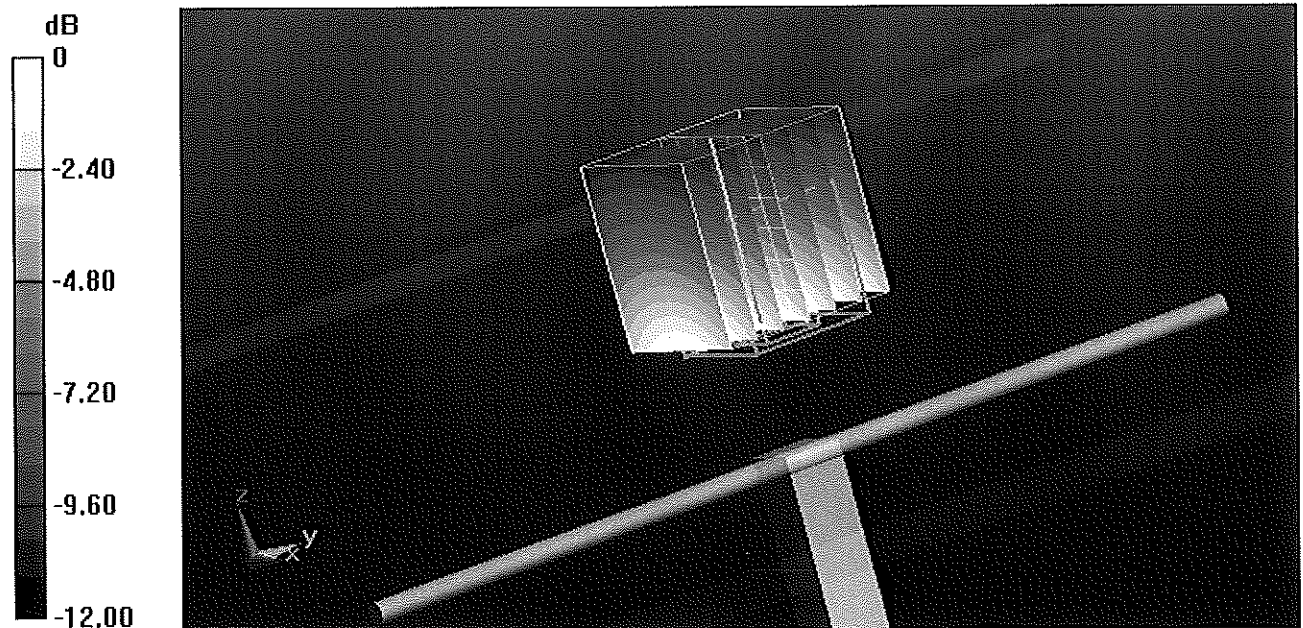

0 dB = 2.75 mW/g = 8.79 dB mW/g

# Impedance Measurement Plot for Head TSL

20 Apr 2012 09:34:14  
[CH1] S11 1 U FS 1: 51.279  $\Omega$  -2.1582  $\Omega$  88.316  $\mu\text{F}$  835.000 000 MHz

\*  
Del  
Cor  
Avg  
16  
H1 d

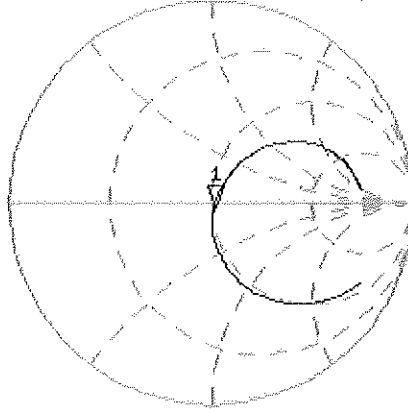

CH2 S11 LOG 5 dB/REF -20 dB 1: -32.106 dB 835.000 000 MHz

Cor  
Avg  
16  
H1 d

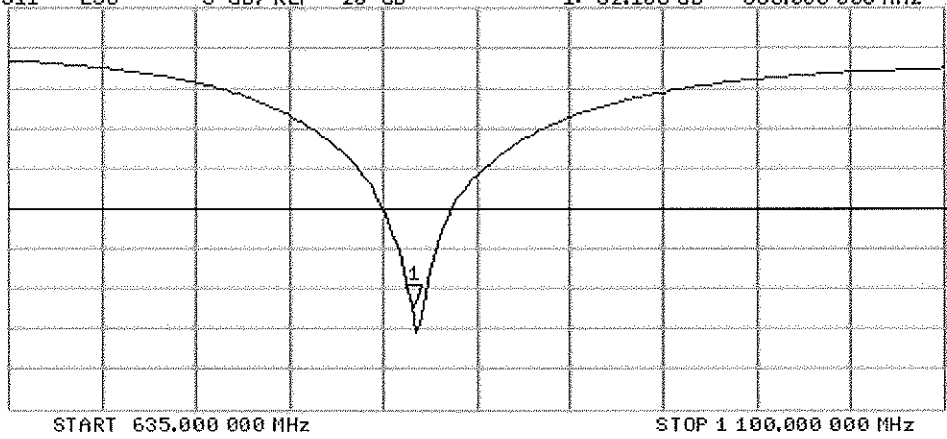

## DASY5 Validation Report for Body TSL

Date: 19.04.2012

Test Laboratory: SPEAG, Zurich, Switzerland

**DUT: Dipole 835 MHz; Type: D835V2; Serial: D835V2 - SN: 4d119**

Communication System: CW; Frequency: 835 MHz

Medium parameters used:  $f = 835$  MHz;  $\sigma = 1.01$  mho/m;  $\epsilon_r = 54.5$ ;  $\rho = 1000$  kg/m<sup>3</sup>

Phantom section: Flat Section

Measurement Standard: DASY5 (IEEE/IEC/ANSI C63.19-2007)

DASY52 Configuration:

- Probe: ES3DV3 - SN3205; ConvF(6.02, 6.02, 6.02); Calibrated: 30.12.2011;
- Sensor-Surface: 3mm (Mechanical Surface Detection)
- Electronics: DAE4 Sn601; Calibrated: 04.07.2011
- Phantom: Flat Phantom 4.9L; Type: QD000P49AA; Serial: 1001
- DASY52 52.8.1(838); SEMCAD X 14.6.5(6469)

**Dipole Calibration for Body Tissue/Pin=250 mW, d=15mm/Zoom Scan (7x7x7)/Cube 0:**

Measurement grid: dx=5mm, dy=5mm, dz=5mm

Reference Value = 55.253 V/m; Power Drift = 0.02 dB

Peak SAR (extrapolated) = 3.571 mW/g

**SAR(1 g) = 2.47 mW/g; SAR(10 g) = 1.62 mW/g**

Maximum value of SAR (measured) = 2.87 mW/g

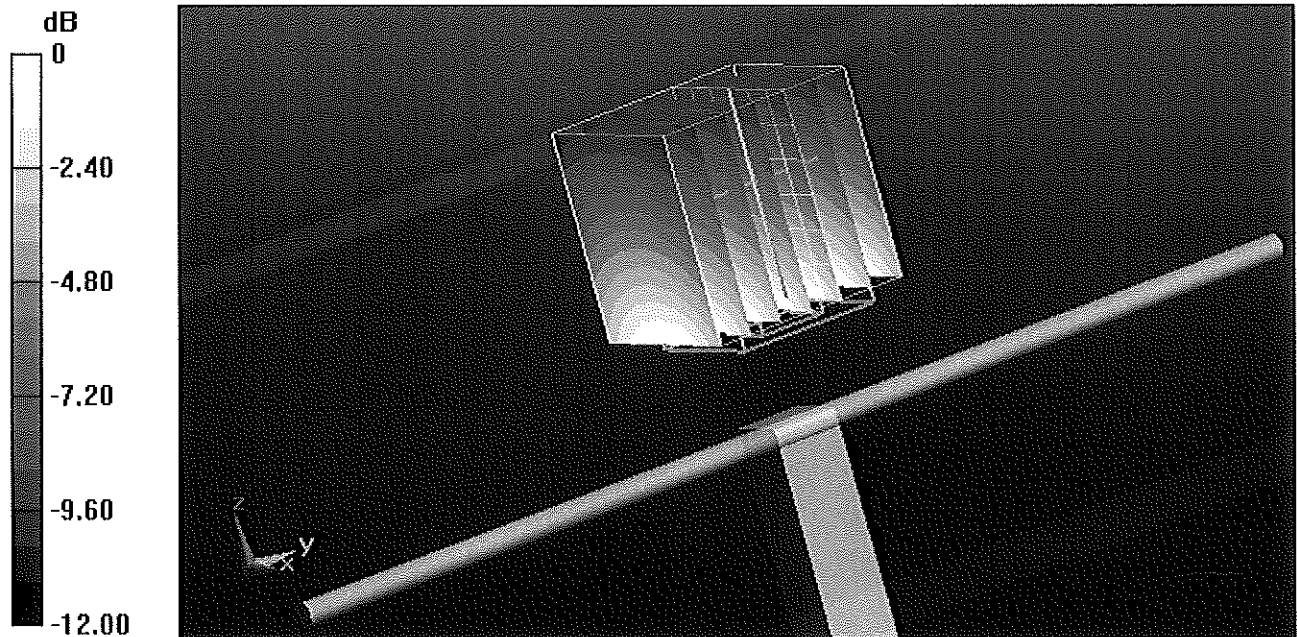

0 dB = 2.87 mW/g = 9.16 dB mW/g

# Impedance Measurement Plot for Body TSL

19 Apr 2012 10:20:53  
 [CH1] S11 1 U FS 1: 46.836  $\Omega$  -4.3203  $\Omega$  44.118  $\mu\text{F}$  835.000 000 MHz

\*  
 De1

Cor

Avg  
 16

H1 d

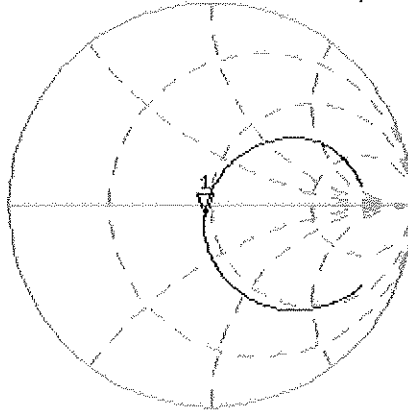

CH2 S11 LOG 5 dB/REF -20 dB 1:-25.155 dB 835.000 000 MHz

Cor

AVG  
 16

H1 d

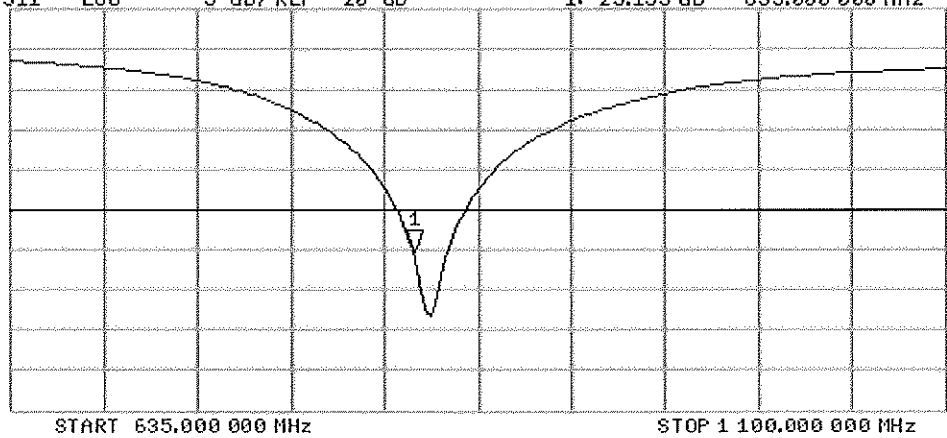



Accredited by the Swiss Accreditation Service (SAS)  
The Swiss Accreditation Service is one of the signatories to the EA  
Multilateral Agreement for the recognition of calibration certificates

Accreditation No.: **SCS 108**

Client **PC Test**

Certificate No: **D835V2-4d132\_Feb12**

**CALIBRATION CERTIFICATE**

Object **D835V2 - SN: 4d132**

Calibration procedure(s) **QA CAL-05.v8  
Calibration procedure for dipole validation kits above 700 MHz**

Calibration date: **February 03, 2012**

*✓ FOK  
5/14/12*

This calibration certificate documents the traceability to national standards, which realize the physical units of measurements (SI).  
The measurements and the uncertainties with confidence probability are given on the following pages and are part of the certificate.

All calibrations have been conducted in the closed laboratory facility: environment temperature (22 ± 3)°C and humidity < 70%.

Calibration Equipment used (M&TE critical for calibration)

Primary Standards	ID #	Cal Date (Certificate No.)	Scheduled Calibration
Power meter EPM-442A	GB37480704	05-Oct-11 (No. 217-01451)	Oct-12
Power sensor HP 8481A	US37292783	05-Oct-11 (No. 217-01451)	Oct-12
Reference 20 dB Attenuator	SN: 5086 (20g)	29-Mar-11 (No. 217-01368)	Apr-12
Type-N mismatch combination	SN: 5047.2 / 06327	29-Mar-11 (No. 217-01371)	Apr-12
Reference Probe ES3DV3	SN: 3205	30-Dec-11 (No. ES3-3205_Dec11)	Dec-12
DAE4	SN: 601	04-Jul-11 (No. DAE4-601_Jul11)	Jul-12
Secondary Standards	ID #	Check Date (in house)	Scheduled Check
Power sensor HP 8481A	MY41092317	18-Oct-02 (in house check Oct-11)	In house check: Oct-13
RF generator R&S SMT-06	100005	04-Aug-99 (in house check Oct-11)	In house check: Oct-13
Network Analyzer HP 8753E	US37390585 S4206	18-Oct-01 (in house check Oct-11)	In house check: Oct-12

Calibrated by:	Name <b>Israe El-Naouq</b>	Function <b>Laboratory Technician</b>	Signature <i>Israe El-Naouq</i>
Approved by:	<b>Katja Pokovic</b>	<b>Technical Manager</b>	<i>[Signature]</i>

Issued: February 3, 2012

This calibration certificate shall not be reproduced except in full without written approval of the laboratory.



Accredited by the Swiss Accreditation Service (SAS)  
The Swiss Accreditation Service is one of the signatories to the EA  
Multilateral Agreement for the recognition of calibration certificates

Accreditation No.: **SCS 108**

### Glossary:

TSL	tissue simulating liquid
ConvF	sensitivity in TSL / NORM x,y,z
N/A	not applicable or not measured

### Calibration is Performed According to the Following Standards:

- IEEE Std 1528-2003, "IEEE Recommended Practice for Determining the Peak Spatial-Averaged Specific Absorption Rate (SAR) in the Human Head from Wireless Communications Devices: Measurement Techniques", December 2003
- IEC 62209-1, "Procedure to measure the Specific Absorption Rate (SAR) for hand-held devices used in close proximity to the ear (frequency range of 300 MHz to 3 GHz)", February 2005
- Federal Communications Commission Office of Engineering & Technology (FCC OET), "Evaluating Compliance with FCC Guidelines for Human Exposure to Radiofrequency Electromagnetic Fields; Additional Information for Evaluating Compliance of Mobile and Portable Devices with FCC Limits for Human Exposure to Radiofrequency Emissions", Supplement C (Edition 01-01) to Bulletin 65

### Additional Documentation:

- DASY4/5 System Handbook

### Methods Applied and Interpretation of Parameters:

- Measurement Conditions:** Further details are available from the Validation Report at the end of the certificate. All figures stated in the certificate are valid at the frequency indicated.
- Antenna Parameters with TSL:** The dipole is mounted with the spacer to position its feed point exactly below the center marking of the flat phantom section, with the arms oriented parallel to the body axis.
- Feed Point Impedance and Return Loss:** These parameters are measured with the dipole positioned under the liquid filled phantom. The impedance stated is transformed from the measurement at the SMA connector to the feed point. The Return Loss ensures low reflected power. No uncertainty required.
- Electrical Delay:** One-way delay between the SMA connector and the antenna feed point. No uncertainty required.
- SAR measured:** SAR measured at the stated antenna input power.
- SAR normalized:** SAR as measured, normalized to an input power of 1 W at the antenna connector.
- SAR for nominal TSL parameters:** The measured TSL parameters are used to calculate the nominal SAR result.



## Measurement Conditions

DASY system configuration, as far as not given on page 1.

<b>DASY Version</b>	DASY5	V52.8.0
<b>Extrapolation</b>	Advanced Extrapolation	
<b>Phantom</b>	Modular Flat Phantom	
<b>Distance Dipole Center - TSL</b>	15 mm	with Spacer
<b>Zoom Scan Resolution</b>	dx, dy, dz = 5 mm	
<b>Frequency</b>	835 MHz ± 1 MHz	

## Head TSL parameters

The following parameters and calculations were applied.

	Temperature	Permittivity	Conductivity
<b>Nominal Head TSL parameters</b>	22.0 °C	41.5	0.90 mho/m
<b>Measured Head TSL parameters</b>	(22.0 ± 0.2) °C	41.8 ± 6 %	0.89 mho/m ± 6 %
<b>Head TSL temperature change during test</b>	< 0.5 °C	----	----

## SAR result with Head TSL

<b>SAR averaged over 1 cm<sup>3</sup> (1 g) of Head TSL</b>	Condition	
SAR measured	250 mW input power	2.34 mW / g
SAR for nominal Head TSL parameters	normalized to 1W	<b>9.45 mW / g ± 17.0 % (k=2)</b>

<b>SAR averaged over 10 cm<sup>3</sup> (10 g) of Head TSL</b>	condition	
SAR measured	250 mW input power	1.53 mW / g
SAR for nominal Head TSL parameters	normalized to 1W	<b>6.17 mW / g ± 16.5 % (k=2)</b>

## Body TSL parameters

The following parameters and calculations were applied.

	Temperature	Permittivity	Conductivity
<b>Nominal Body TSL parameters</b>	22.0 °C	55.2	0.97 mho/m
<b>Measured Body TSL parameters</b>	(22.0 ± 0.2) °C	53.3 ± 6 %	0.98 mho/m ± 6 %
<b>Body TSL temperature change during test</b>	< 0.5 °C	----	----

## SAR result with Body TSL

<b>SAR averaged over 1 cm<sup>3</sup> (1 g) of Body TSL</b>	Condition	
SAR measured	250 mW input power	2.39 mW / g
SAR for nominal Body TSL parameters	normalized to 1W	<b>9.41 mW / g ± 17.0 % (k=2)</b>

<b>SAR averaged over 10 cm<sup>3</sup> (10 g) of Body TSL</b>	condition	
SAR measured	250 mW input power	1.57 mW / g
SAR for nominal Body TSL parameters	normalized to 1W	<b>6.21 mW / g ± 16.5 % (k=2)</b>

## Appendix

### Antenna Parameters with Head TSL

Impedance, transformed to feed point	52.7 $\Omega$ - 2.3 j $\Omega$
Return Loss	- 29.2 dB

### Antenna Parameters with Body TSL

Impedance, transformed to feed point	48.9 $\Omega$ - 3.5 j $\Omega$
Return Loss	- 28.7 dB

### General Antenna Parameters and Design

Electrical Delay (one direction)	1.392 ns
----------------------------------	----------

After long term use with 100W radiated power, only a slight warming of the dipole near the feedpoint can be measured.

The dipole is made of standard semirigid coaxial cable. The center conductor of the feeding line is directly connected to the second arm of the dipole. The antenna is therefore short-circuited for DC-signals. On some of the dipoles, small end caps are added to the dipole arms in order to improve matching when loaded according to the position as explained in the "Measurement Conditions" paragraph. The SAR data are not affected by this change. The overall dipole length is still according to the Standard.

No excessive force must be applied to the dipole arms, because they might bend or the soldered connections near the feedpoint may be damaged.

### Additional EUT Data

Manufactured by	SPEAG
Manufactured on	July 22, 2011

## DASY5 Validation Report for Head TSL

Date: 03.02.2012

Test Laboratory: SPEAG, Zurich, Switzerland

**DUT: Dipole 835 MHz; Type: D835V2; Serial: D835V2 - SN: 4d132**

Communication System: CW; Frequency: 835 MHz

Medium parameters used:  $f = 835$  MHz;  $\sigma = 0.89$  mho/m;  $\epsilon_r = 41.8$ ;  $\rho = 1000$  kg/m<sup>3</sup>

Phantom section: Flat Section

Measurement Standard: DASY5 (IEEE/IEC/ANSI C63.19-2007)

DASY52 Configuration:

- Probe: ES3DV3 - SN3205; ConvF(6.07, 6.07, 6.07); Calibrated: 30.12.2011
- Sensor-Surface: 3mm (Mechanical Surface Detection)
- Electronics: DAE4 Sn601; Calibrated: 04.07.2011
- Phantom: Flat Phantom 4.9L; Type: QD000P49AA; Serial: 1001
- DASY52 52.8.0(692); SEMCAD X 14.6.4(4989)

### **Dipole Calibration for Head Tissue/Pin=250 mW, d=15mm/Zoom Scan (7x7x7)/Cube 0:**

Measurement grid: dx=5mm, dy=5mm, dz=5mm

Reference Value = 56.867 V/m; Power Drift = 0.05 dB

Peak SAR (extrapolated) = 3.4300

**SAR(1 g) = 2.34 mW/g; SAR(10 g) = 1.53 mW/g**

Maximum value of SAR (measured) = 2.701 mW/g

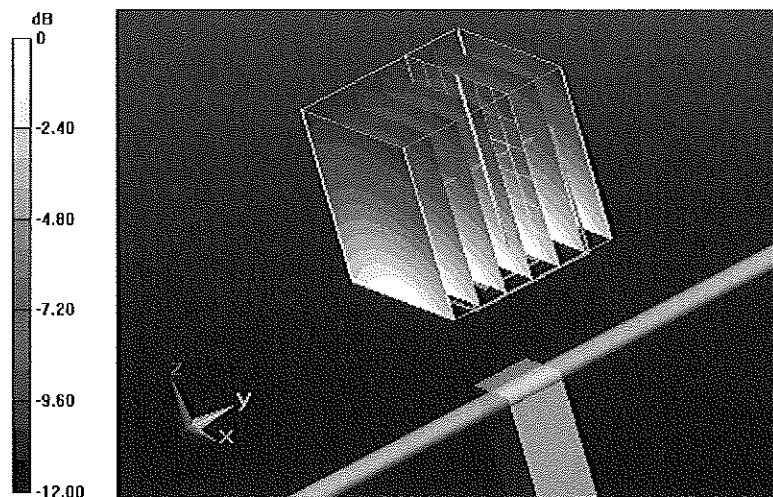

0 dB = 2.700mW/g = 8.63 dB mW/g

# Impedance Measurement Plot for Head TSL

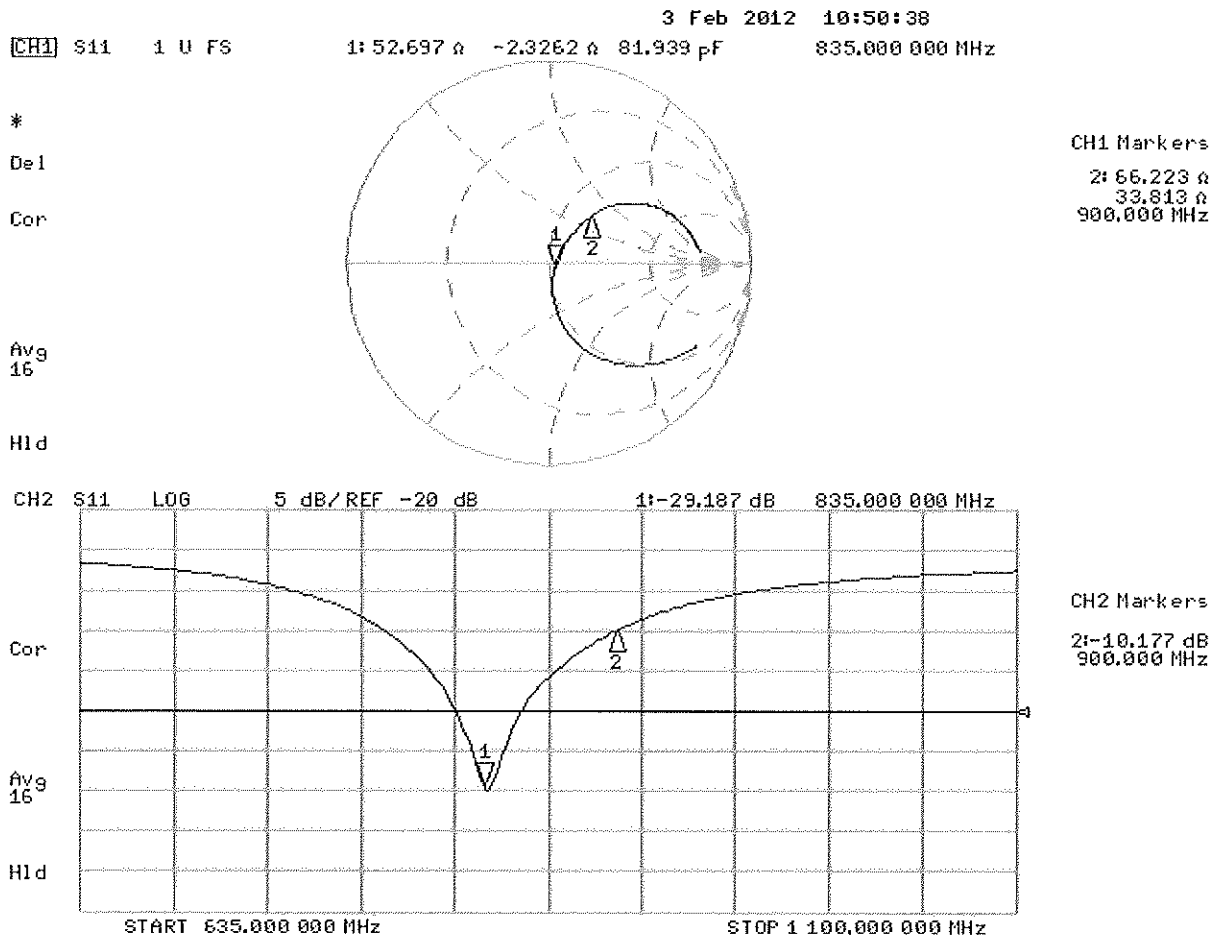

## DASY5 Validation Report for Body TSL

Date: 02.02.2012

Test Laboratory: SPEAG, Zurich, Switzerland

**DUT: Dipole 835 MHz; Type: D835V2; Serial: D835V2 - SN: 4d132**

Communication System: CW; Frequency: 835 MHz

Medium parameters used:  $f = 835$  MHz;  $\sigma = 0.98$  mho/m;  $\epsilon_r = 53.3$ ;  $\rho = 1000$  kg/m<sup>3</sup>

Phantom section: Flat Section

Measurement Standard: DASY5 (IEEE/IEC/ANSI C63.19-2007)

DASY52 Configuration:

- Probe: ES3DV3 - SN3205; ConvF(6.02, 6.02, 6.02); Calibrated: 30.12.2011
- Sensor-Surface: 3mm (Mechanical Surface Detection)
- Electronics: DAE4 Sn601; Calibrated: 04.07.2011
- Phantom: Flat Phantom 4.9L; Type: QD000P49AA; Serial: 1001
- DASY52 52.8.0(692); SEMCAD X 14.6.4(4989)

### Dipole Calibration for Body Tissue/Pin=250 mW, d=15mm/Zoom Scan (7x7x7)/Cube 0:

Measurement grid: dx=5mm, dy=5mm, dz=5mm

Reference Value = 55.137 V/m; Power Drift = 0.01 dB

Peak SAR (extrapolated) = 3.4770

**SAR(1 g) = 2.39 mW/g; SAR(10 g) = 1.57 mW/g**

Maximum value of SAR (measured) = 2.781 mW/g

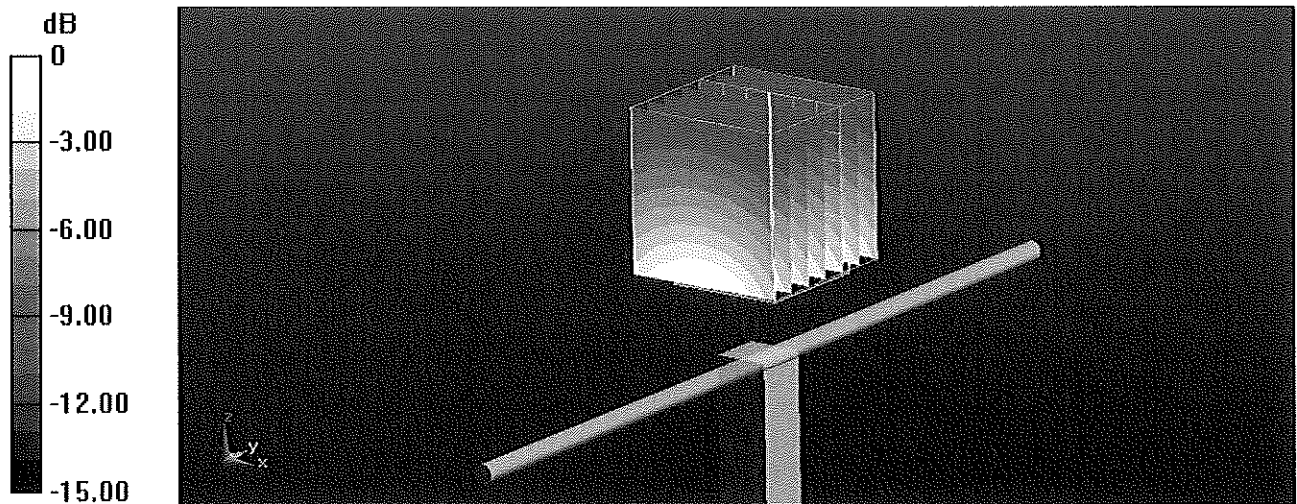

0 dB = 2.780mW/g = 8.88 dB mW/g

# Impedance Measurement Plot for Body TSL

2 Feb 2012 17:18:48

CH1 S11 1 U FS 1: 48.902  $\Omega$  -3.4570  $\Omega$  55.135 pF 835.000 000 MHz

\*  
De1  
Cor  
Avg  
16  
H1d

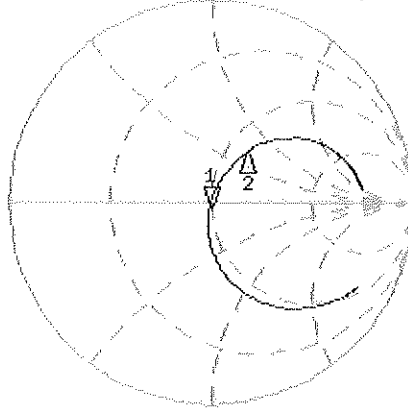

CH1 Markers  
2: 61.023  $\Omega$   
32.770  $\Omega$   
900.000 MHz

CH2 S11 LOG 5 dB/REF -20 dB 1:-28.730 dB 835.000 000 MHz

Cor  
Avg  
16  
H1d

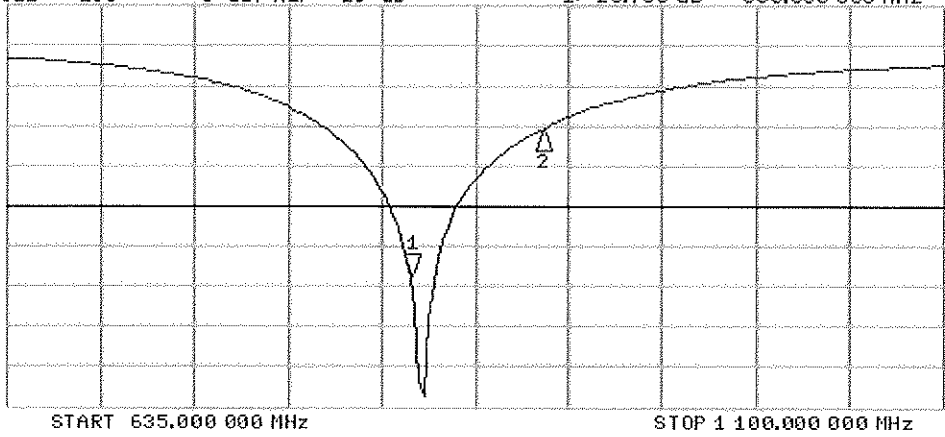

CH2 Markers  
2: -10.497 dB  
900.000 MHz



Accredited by the Swiss Accreditation Service (SAS)  
The Swiss Accreditation Service is one of the signatories to the EA  
Multilateral Agreement for the recognition of calibration certificates

Accreditation No.: **SCS 108**

Client **PC Test**

Certificate No: **D1750V2-1051\_Apr12**

**CALIBRATION CERTIFICATE**

Object **D1750V2 - SN: 1051**

Calibration procedure(s) **QA CAL-05.v8  
Calibration procedure for dipole validation kits above 700 MHz**

Calibration date: **April 24, 2012**

*VOK  
5/4/12*

This calibration certificate documents the traceability to national standards, which realize the physical units of measurements (SI).  
The measurements and the uncertainties with confidence probability are given on the following pages and are part of the certificate.

All calibrations have been conducted in the closed laboratory facility: environment temperature (22 ± 3)°C and humidity < 70%.

Calibration Equipment used (M&TE critical for calibration)

Primary Standards	ID #	Cal Date (Certificate No.)	Scheduled Calibration
Power meter EPM-442A	GB37480704	05-Oct-11 (No. 217-01451)	Oct-12
Power sensor HP 8481A	US37292783	05-Oct-11 (No. 217-01451)	Oct-12
Reference 20 dB Attenuator	SN: 5058 (20k)	27-Mar-12 (No. 217-01530)	Apr-13
Type-N mismatch combination	SN: 5047.2 / 06327	27-Mar-12 (No. 217-01533)	Apr-13
Reference Probe ES3DV3	SN: 3205	30-Dec-11 (No. ES3-3205_Dec11)	Dec-12
DAE4	SN: 601	04-Jul-11 (No. DAE4-601_Jul11)	Jul-12
Secondary Standards	ID #	Check Date (in house)	Scheduled Check
Power sensor HP 8481A	MY41092317	18-Oct-02 (in house check Oct-11)	In house check: Oct-13
RF generator R&S SMT-06	100005	04-Aug-99 (in house check Oct-11)	In house check: Oct-13
Network Analyzer HP 8753E	US37390585 S4206	18-Oct-01 (in house check Oct-11)	In house check: Oct-12

Calibrated by: **Dimce Iliev** Laboratory Technician *D. Iliev*

Approved by: **Katja Pokovic** Technical Manager *Katja Pokovic*

Issued: April 24, 2012

This calibration certificate shall not be reproduced except in full without written approval of the laboratory.



Accredited by the Swiss Accreditation Service (SAS)

The Swiss Accreditation Service is one of the signatories to the EA Multilateral Agreement for the recognition of calibration certificates

Accreditation No.: **SCS 108**

### Glossary:

TSL	tissue simulating liquid
ConvF	sensitivity in TSL / NORM x,y,z
N/A	not applicable or not measured

### Calibration is Performed According to the Following Standards:

- IEEE Std 1528-2003, "IEEE Recommended Practice for Determining the Peak Spatial-Averaged Specific Absorption Rate (SAR) in the Human Head from Wireless Communications Devices: Measurement Techniques", December 2003
- IEC 62209-1, "Procedure to measure the Specific Absorption Rate (SAR) for hand-held devices used in close proximity to the ear (frequency range of 300 MHz to 3 GHz)", February 2005
- Federal Communications Commission Office of Engineering & Technology (FCC OET), "Evaluating Compliance with FCC Guidelines for Human Exposure to Radiofrequency Electromagnetic Fields; Additional Information for Evaluating Compliance of Mobile and Portable Devices with FCC Limits for Human Exposure to Radiofrequency Emissions", Supplement C (Edition 01-01) to Bulletin 65

### Additional Documentation:

- DASY4/5 System Handbook

### Methods Applied and Interpretation of Parameters:

- Measurement Conditions:** Further details are available from the Validation Report at the end of the certificate. All figures stated in the certificate are valid at the frequency indicated.
- Antenna Parameters with TSL:** The dipole is mounted with the spacer to position its feed point exactly below the center marking of the flat phantom section, with the arms oriented parallel to the body axis.
- Feed Point Impedance and Return Loss:** These parameters are measured with the dipole positioned under the liquid filled phantom. The impedance stated is transformed from the measurement at the SMA connector to the feed point. The Return Loss ensures low reflected power. No uncertainty required.
- Electrical Delay:** One-way delay between the SMA connector and the antenna feed point. No uncertainty required.
- SAR measured:** SAR measured at the stated antenna input power.
- SAR normalized:** SAR as measured, normalized to an input power of 1 W at the antenna connector.
- SAR for nominal TSL parameters:** The measured TSL parameters are used to calculate the nominal SAR result.

The reported uncertainty of measurement is stated as the standard uncertainty of measurement multiplied by the coverage factor  $k=2$ , which for a normal distribution corresponds to a coverage probability of approximately 95%.



## Measurement Conditions

DASY system configuration, as far as not given on page 1.

DASY Version	DASY5	V52.8.1
Extrapolation	Advanced Extrapolation	
Phantom	Modular Flat Phantom	
Distance Dipole Center - TSL	10 mm	with Spacer
Zoom Scan Resolution	dx, dy, dz = 5 mm	
Frequency	1750 MHz ± 1 MHz	

## Head TSL parameters

The following parameters and calculations were applied.

	Temperature	Permittivity	Conductivity
Nominal Head TSL parameters	22.0 °C	40.1	1.37 mho/m
Measured Head TSL parameters	(22.0 ± 0.2) °C	40.6 ± 6 %	1.35 mho/m ± 6 %
Head TSL temperature change during test	< 0.5 °C	----	----

## SAR result with Head TSL

SAR averaged over 1 cm <sup>3</sup> (1 g) of Head TSL	Condition	
SAR measured	250 mW input power	9.03 mW / g
SAR for nominal Head TSL parameters	normalized to 1W	36.6 mW / g ± 17.0 % (k=2)

SAR averaged over 10 cm <sup>3</sup> (10 g) of Head TSL	condition	
SAR measured	250 mW input power	4.83 mW / g
SAR for nominal Head TSL parameters	normalized to 1W	19.5 mW / g ± 16.5 % (k=2)

## Body TSL parameters

The following parameters and calculations were applied.

	Temperature	Permittivity	Conductivity
Nominal Body TSL parameters	22.0 °C	53.4	1.49 mho/m
Measured Body TSL parameters	(22.0 ± 0.2) °C	52.9 ± 6 %	1.47 mho/m ± 6 %
Body TSL temperature change during test	< 0.5 °C	----	----

## SAR result with Body TSL

SAR averaged over 1 cm <sup>3</sup> (1 g) of Body TSL	Condition	
SAR measured	250 mW input power	9.33 mW / g
SAR for nominal Body TSL parameters	normalized to 1W	37.6 mW / g ± 17.0 % (k=2)

SAR averaged over 10 cm <sup>3</sup> (10 g) of Body TSL	condition	
SAR measured	250 mW input power	5.03 mW / g
SAR for nominal Body TSL parameters	normalized to 1W	20.2 mW / g ± 16.5 % (k=2)

## Appendix

### Antenna Parameters with Head TSL

Impedance, transformed to feed point	50.7 $\Omega$ - 0.2 j $\Omega$
Return Loss	- 42.8 dB

### Antenna Parameters with Body TSL

Impedance, transformed to feed point	46.0 $\Omega$ + 0.0 j $\Omega$
Return Loss	- 27.5 dB

### General Antenna Parameters and Design

Electrical Delay (one direction)	1.222 ns
----------------------------------	----------

After long term use with 100W radiated power, only a slight warming of the dipole near the feedpoint can be measured.

The dipole is made of standard semirigid coaxial cable. The center conductor of the feeding line is directly connected to the second arm of the dipole. The antenna is therefore short-circuited for DC-signals. On some of the dipoles, small end caps are added to the dipole arms in order to improve matching when loaded according to the position as explained in the "Measurement Conditions" paragraph. The SAR data are not affected by this change. The overall dipole length is still according to the Standard.

No excessive force must be applied to the dipole arms, because they might bend or the soldered connections near the feedpoint may be damaged.

### Additional EUT Data

Manufactured by	SPEAG
Manufactured on	February 19, 2010

## DASY5 Validation Report for Head TSL

Date: 24.04.2012

Test Laboratory: SPEAG, Zurich, Switzerland

**DUT: Dipole 1750 MHz; Type: D1750V2; Serial: D1750V2 - SN: 1051**

Communication System: CW; Frequency: 1750 MHz

Medium parameters used:  $f = 1750$  MHz;  $\sigma = 1.35$  mho/m;  $\epsilon_r = 40.6$ ;  $\rho = 1000$  kg/m<sup>3</sup>

Phantom section: Flat Section

Measurement Standard: DASY5 (IEEE/IEC/ANSI C63.19-2007)

DASY52 Configuration:

- Probe: ES3DV3 - SN3205; ConvF(5.22, 5.22, 5.22); Calibrated: 30.12.2011;
- Sensor-Surface: 3mm (Mechanical Surface Detection)
- Electronics: DAE4 Sn601; Calibrated: 04.07.2011
- Phantom: Flat Phantom 5.0 (front); Type: QD000P50AA; Serial: 1001
- DASY52 52.8.1(838); SEMCAD X 14.6.5(6469)

### Dipole Calibration for Head Tissue/Pin=250 mW, d=10mm/Zoom Scan (7x7x7)/Cube 0:

Measurement grid: dx=5mm, dy=5mm, dz=5mm

Reference Value = 93.857 V/m; Power Drift = 0.05 dB

Peak SAR (extrapolated) = 16.022 mW/g

**SAR(1 g) = 9.03 mW/g; SAR(10 g) = 4.83 mW/g**

Maximum value of SAR (measured) = 11.2 mW/g

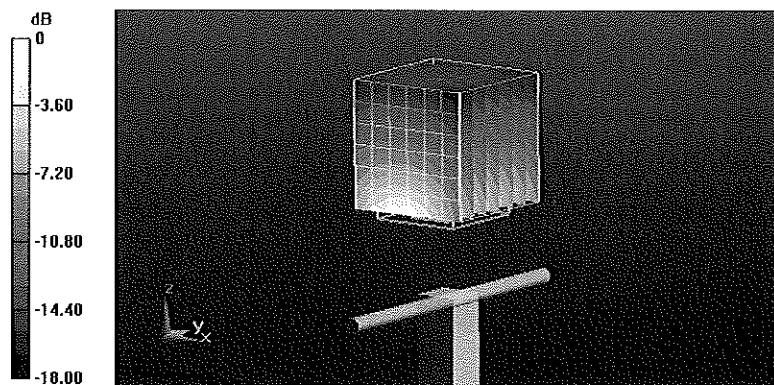

0 dB = 11.2 mW/g = 20.98 dB mW/g

# Impedance Measurement Plot for Head TSL

24 Apr 2012 09:49:22

[CHI] S11 1 U FS 1: 50.672  $\Omega$  -216.80 m $\Omega$  419.50 pF 1 750.000 000 MHz

\*

Del

Cor

Avg  
16

H1d

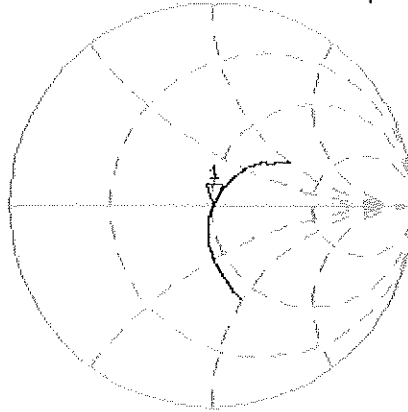

CH2 S11 LOG 5 dB/REF -20 dB 1:-42.822 dB 1 750.000 000 MHz

Cor

Avg  
16

H1d

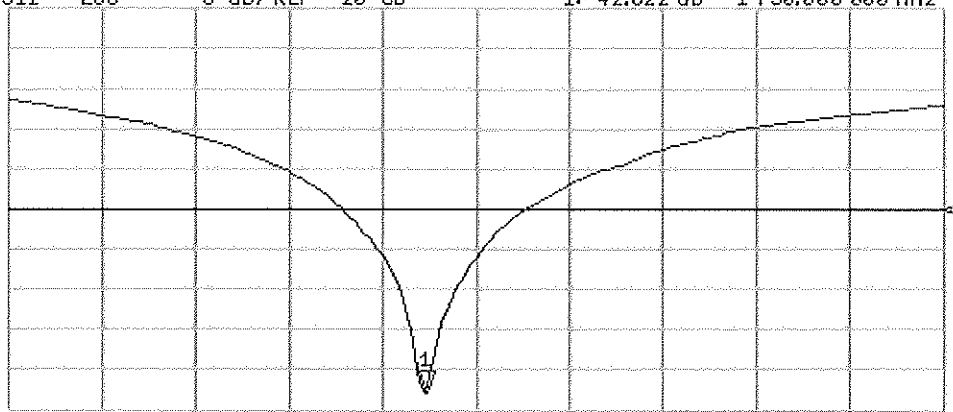

START 1 550.000 000 MHz

STOP 2 000.000 000 MHz

# DASY5 Validation Report for Body TSL

Date: 24.04.2012

Test Laboratory: SPEAG, Zurich, Switzerland

**DUT: Dipole 1750 MHz; Type: D1750V2; Serial: D1750V2 - SN: 1051**

Communication System: CW; Frequency: 1750 MHz

Medium parameters used:  $f = 1750$  MHz;  $\sigma = 1.47$  mho/m;  $\epsilon_r = 52.9$ ;  $\rho = 1000$  kg/m<sup>3</sup>

Phantom section: Flat Section

Measurement Standard: DASY5 (IEEE/IEC/ANSI C63.19-2007)

DASY52 Configuration:

- Probe: ES3DV3 - SN3205; ConvF(4.85, 4.85, 4.85); Calibrated: 30.12.2011;
- Sensor-Surface: 3mm (Mechanical Surface Detection)
- Electronics: DAE4 Sn601; Calibrated: 04.07.2011
- Phantom: Flat Phantom 5.0 (back); Type: QD000P50AA; Serial: 1002
- DASY52 52.8.1(838); SEMCAD X 14.6.5(6469)

## Dipole Calibration for Body Tissue/Pin=250 mW, d=10mm/Zoom Scan (7x7x7)/Cube 0:

Measurement grid: dx=5mm, dy=5mm, dz=5mm

Reference Value = 93.394 V/m; Power Drift = -0.01 dB

Peak SAR (extrapolated) = 15.953 mW/g

**SAR(1 g) = 9.33 mW/g; SAR(10 g) = 5.03 mW/g**

Maximum value of SAR (measured) = 11.7 mW/g

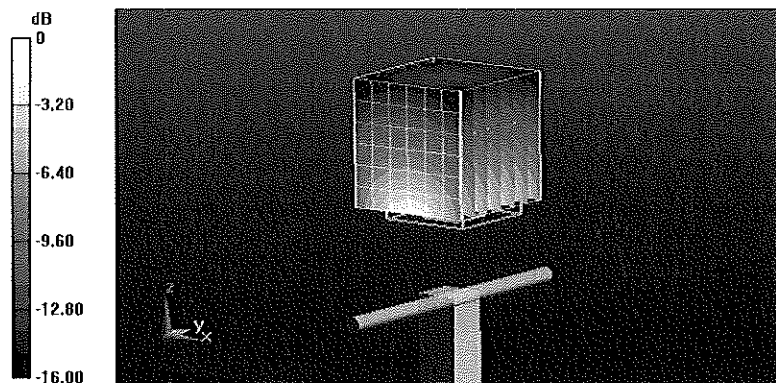

0 dB = 11.7 mW/g = 21.36 dB mW/g

# Impedance Measurement Plot for Body TSL

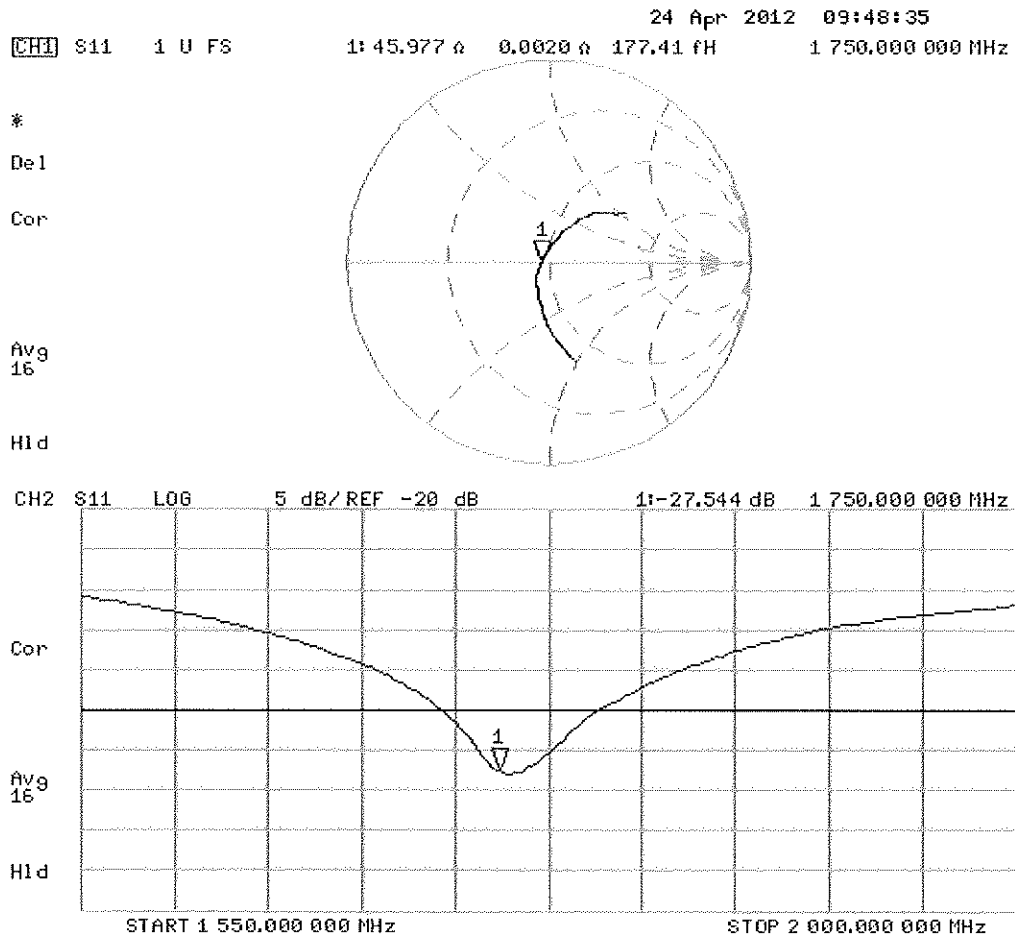



Accredited by the Swiss Accreditation Service (SAS)  
The Swiss Accreditation Service is one of the signatories to the EA  
Multilateral Agreement for the recognition of calibration certificates

Accreditation No.: **SCS 108**

Client **PC Test**

Certificate No: **D1900V2-5d149\_Feb12**

**CALIBRATION CERTIFICATE**

Object **D1900V2 - SN: 5d149**

Calibration procedure(s) **QA CAL-05.v8  
Calibration procedure for dipole validation kits above 700 MHz**

Calibration date: **February 22, 2012**

*✓ KOK  
4/11/12*

This calibration certificate documents the traceability to national standards, which realize the physical units of measurements (SI).  
The measurements and the uncertainties with confidence probability are given on the following pages and are part of the certificate.

All calibrations have been conducted in the closed laboratory facility: environment temperature (22 ± 3)°C and humidity < 70%.

Calibration Equipment used (M&TE critical for calibration)

Primary Standards	ID #	Cal Date (Certificate No.)	Scheduled Calibration
Power meter EPM-442A	GB37480704	05-Oct-11 (No. 217-01451)	Oct-12
Power sensor HP 8481A	US37292783	05-Oct-11 (No. 217-01451)	Oct-12
Reference 20 dB Attenuator	SN: 5086 (20g)	29-Mar-11 (No. 217-01368)	Apr-12
Type-N mismatch combination	SN: 5047.2 / 06327	29-Mar-11 (No. 217-01371)	Apr-12
Reference Probe ES3DV3	SN: 3205	30-Dec-11 (No. ES3-3205_Dec11)	Dec-12
DAE4	SN: 601	04-Jul-11 (No. DAE4-601_Jul11)	Jul-12
Secondary Standards	ID #	Check Date (in house)	Scheduled Check
Power sensor HP 8481A	MY41092317	18-Oct-02 (in house check Oct-11)	In house check: Oct-13
RF generator R&S SMT-06	100005	04-Aug-99 (in house check Oct-11)	In house check: Oct-13
Network Analyzer HP 8753E	US37390585 S4206	18-Oct-01 (in house check Oct-11)	In house check: Oct-12

Calibrated by: **Name** **Function** **Signature**  
**Israe El-Naouq** **Laboratory Technician** *Israe El-Naouq*

Approved by: **Name** **Function**  
**Katja Pokovic** **Technical Manager** *Katja Pokovic*

Issued: February 23, 2012

This calibration certificate shall not be reproduced except in full without written approval of the laboratory.



Accredited by the Swiss Accreditation Service (SAS)

The Swiss Accreditation Service is one of the signatories to the EA Multilateral Agreement for the recognition of calibration certificates

Accreditation No.: **SCS 108**

### Glossary:

TSL	tissue simulating liquid
ConvF	sensitivity in TSL / NORM x,y,z
N/A	not applicable or not measured

### Calibration is Performed According to the Following Standards:

- IEEE Std 1528-2003, "IEEE Recommended Practice for Determining the Peak Spatial-Averaged Specific Absorption Rate (SAR) in the Human Head from Wireless Communications Devices: Measurement Techniques", December 2003
- IEC 62209-1, "Procedure to measure the Specific Absorption Rate (SAR) for hand-held devices used in close proximity to the ear (frequency range of 300 MHz to 3 GHz)", February 2005
- Federal Communications Commission Office of Engineering & Technology (FCC OET), "Evaluating Compliance with FCC Guidelines for Human Exposure to Radiofrequency Electromagnetic Fields; Additional Information for Evaluating Compliance of Mobile and Portable Devices with FCC Limits for Human Exposure to Radiofrequency Emissions", Supplement C (Edition 01-01) to Bulletin 65

### Additional Documentation:

- DASY4/5 System Handbook

### Methods Applied and Interpretation of Parameters:

- Measurement Conditions:** Further details are available from the Validation Report at the end of the certificate. All figures stated in the certificate are valid at the frequency indicated.
- Antenna Parameters with TSL:** The dipole is mounted with the spacer to position its feed point exactly below the center marking of the flat phantom section, with the arms oriented parallel to the body axis.
- Feed Point Impedance and Return Loss:** These parameters are measured with the dipole positioned under the liquid filled phantom. The impedance stated is transformed from the measurement at the SMA connector to the feed point. The Return Loss ensures low reflected power. No uncertainty required.
- Electrical Delay:** One-way delay between the SMA connector and the antenna feed point. No uncertainty required.
- SAR measured:** SAR measured at the stated antenna input power.
- SAR normalized:** SAR as measured, normalized to an input power of 1 W at the antenna connector.
- SAR for nominal TSL parameters:** The measured TSL parameters are used to calculate the nominal SAR result.



## Measurement Conditions

DASY system configuration, as far as not given on page 1.

DASY Version	DASY5	V52.8.0
Extrapolation	Advanced Extrapolation	
Phantom	Modular Flat Phantom	
Distance Dipole Center - TSL	10 mm	with Spacer
Zoom Scan Resolution	dx, dy, dz = 5 mm	
Frequency	1900 MHz $\pm$ 1 MHz	

## Head TSL parameters

The following parameters and calculations were applied.

	Temperature	Permittivity	Conductivity
Nominal Head TSL parameters	22.0 °C	40.0	1.40 mho/m
Measured Head TSL parameters	(22.0 $\pm$ 0.2) °C	40.4 $\pm$ 6 %	1.40 mho/m $\pm$ 6 %
Head TSL temperature change during test	< 0.5 °C	----	----

## SAR result with Head TSL

SAR averaged over 1 cm <sup>3</sup> (1 g) of Head TSL	Condition	
SAR measured	250 mW input power	9.80 mW / g
SAR for nominal Head TSL parameters	normalized to 1W	<b>39.3 mW / g <math>\pm</math> 17.0 % (k=2)</b>

SAR averaged over 10 cm <sup>3</sup> (10 g) of Head TSL	condition	
SAR measured	250 mW input power	5.18 mW / g
SAR for nominal Head TSL parameters	normalized to 1W	<b>20.7 mW / g <math>\pm</math> 16.5 % (k=2)</b>

## Body TSL parameters

The following parameters and calculations were applied.

	Temperature	Permittivity	Conductivity
Nominal Body TSL parameters	22.0 °C	53.3	1.52 mho/m
Measured Body TSL parameters	(22.0 $\pm$ 0.2) °C	53.0 $\pm$ 6 %	1.56 mho/m $\pm$ 6 %
Body TSL temperature change during test	< 0.5 °C	----	----

## SAR result with Body TSL

SAR averaged over 1 cm <sup>3</sup> (1 g) of Body TSL	Condition	
SAR measured	250 mW input power	9.99 mW / g
SAR for nominal Body TSL parameters	normalized to 1W	<b>39.3 mW / g <math>\pm</math> 17.0 % (k=2)</b>

SAR averaged over 10 cm <sup>3</sup> (10 g) of Body TSL	condition	
SAR measured	250 mW input power	5.23 mW / g
SAR for nominal Body TSL parameters	normalized to 1W	<b>20.7 mW / g <math>\pm</math> 16.5 % (k=2)</b>

## Appendix

### Antenna Parameters with Head TSL

Impedance, transformed to feed point	52.4 $\Omega$ + 5.5 j $\Omega$
Return Loss	- 24.6 dB

### Antenna Parameters with Body TSL

Impedance, transformed to feed point	48.0 $\Omega$ + 6.7 j $\Omega$
Return Loss	- 23.0 dB

### General Antenna Parameters and Design

Electrical Delay (one direction)	1.199 ns
----------------------------------	----------

After long term use with 100W radiated power, only a slight warming of the dipole near the feedpoint can be measured.

The dipole is made of standard semirigid coaxial cable. The center conductor of the feeding line is directly connected to the second arm of the dipole. The antenna is therefore short-circuited for DC-signals. On some of the dipoles, small end caps are added to the dipole arms in order to improve matching when loaded according to the position as explained in the "Measurement Conditions" paragraph. The SAR data are not affected by this change. The overall dipole length is still according to the Standard.

No excessive force must be applied to the dipole arms, because they might bend or the soldered connections near the feedpoint may be damaged.

### Additional EUT Data

Manufactured by	SPEAG
Manufactured on	March 11, 2011

# DASY5 Validation Report for Head TSL

Date: 22.02.2012

Test Laboratory: SPEAG, Zurich, Switzerland

**DUT: Dipole 1900 MHz; Type: D1900V2; Serial: D1900V2 - SN: 5d149**

Communication System: CW; Frequency: 1900 MHz

Medium parameters used:  $f = 1900$  MHz;  $\sigma = 1.4$  mho/m;  $\epsilon_r = 40.4$ ;  $\rho = 1000$  kg/m<sup>3</sup>

Phantom section: Flat Section

Measurement Standard: DASY5 (IEEE/IEC/ANSI C63.19-2007)

DASY52 Configuration:

- Probe: ES3DV3 - SN3205; ConvF(5.01, 5.01, 5.01); Calibrated: 30.12.2011
- Sensor-Surface: 3mm (Mechanical Surface Detection)
- Electronics: DAE4 Sn601; Calibrated: 04.07.2011
- Phantom: Flat Phantom 5.0 (front); Type: QD000P50AA; Serial: 1001
- DASY52 52.8.0(692); SEMCAD X 14.6.4(4989)

## Dipole Calibration for Head Tissue/Pin=250 mW, d=10mm/Zoom Scan (7x7x7)/Cube 0:

Measurement grid: dx=5mm, dy=5mm, dz=5mm

Reference Value = 96.685 V/m; Power Drift = 0.04 dB

Peak SAR (extrapolated) = 17.4710

**SAR(1 g) = 9.8 mW/g; SAR(10 g) = 5.18 mW/g**

Maximum value of SAR (measured) = 12.114 mW/g

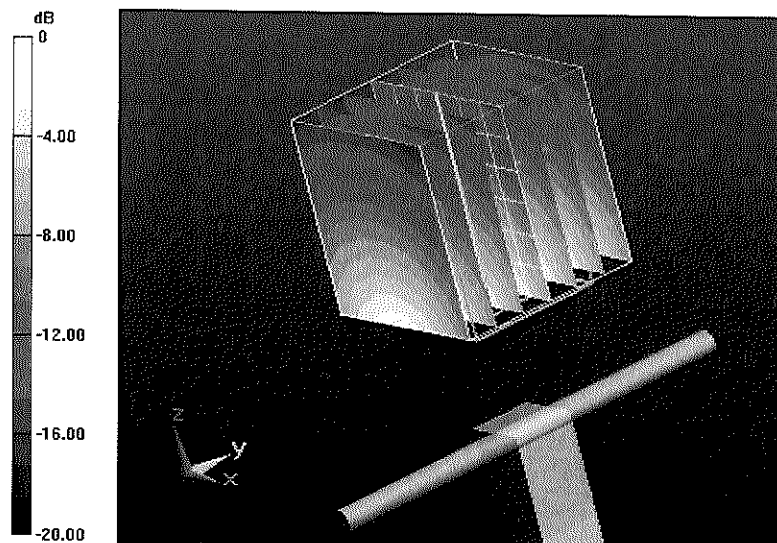

0 dB = 12.110mW/g = 21.66 dB mW/g

# Impedance Measurement Plot for Head TSL

22 Feb 2012 09:56:56

CH1 S11 1 U FS Z: 52.387  $\Omega$  5.5059  $\Omega$  461.20  $\mu$ H 1 900.000 000 MHz

\*  
De1  
Cor  
Avg  
16  
H1d

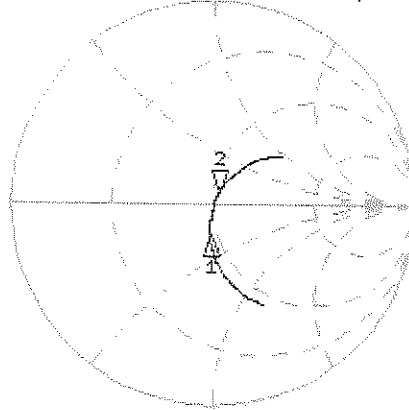

CH1 Markers  
1: 46.287  $\Omega$   
-15.180  $\Omega$   
1.80000 GHz

CH2 S11 LOG 5 dB/REF -20 dB 2: -24.647 dB 1 900.000 000 MHz

Cor  
Avg  
15  
H1d

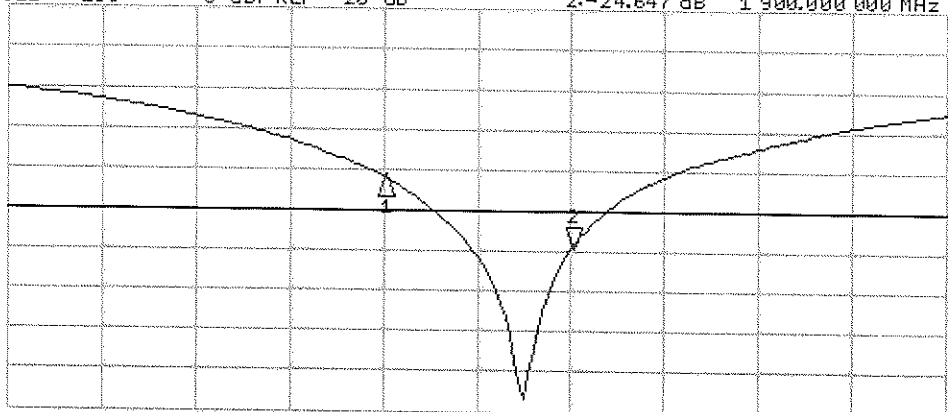

CH2 Markers  
1: -15.901 dB  
1.80000 GHz

# DASY5 Validation Report for Body TSL

Date: 06.02.2012

Test Laboratory: SPEAG, Zurich, Switzerland

**DUT: Dipole 1900 MHz; Type: D1900V2; Serial: D1900V2 - SN: 5d149**

Communication System: CW; Frequency: 1900 MHz

Medium parameters used:  $f = 1900$  MHz;  $\sigma = 1.56$  mho/m;  $\epsilon_r = 53$ ;  $\rho = 1000$  kg/m<sup>3</sup>

Phantom section: Flat Section

Measurement Standard: DASY5 (IEEE/IEC/ANSI C63.19-2007)

DASY52 Configuration:

- Probe: ES3DV3 - SN3205; ConvF(4.62, 4.62, 4.62); Calibrated: 30.12.2011
- Sensor-Surface: 3mm (Mechanical Surface Detection)
- Electronics: DAE4 Sn601; Calibrated: 04.07.2011
- Phantom: Flat Phantom 5.0 (back); Type: QD000P50AA; Serial: 1002
- DASY52 52.8.0(692); SEMCAD X 14.6.4(4989)

## Dipole Calibration for Body Tissue/Pin=250 mW, d=10mm/Zoom Scan (7x7x7)/Cube 0:

Measurement grid: dx=5mm, dy=5mm, dz=5mm

Reference Value = 94.047 V/m; Power Drift = 0.0017 dB

Peak SAR (extrapolated) = 18.1310

**SAR(1 g) = 9.99 mW/g; SAR(10 g) = 5.23 mW/g**

Maximum value of SAR (measured) = 12.672 mW/g

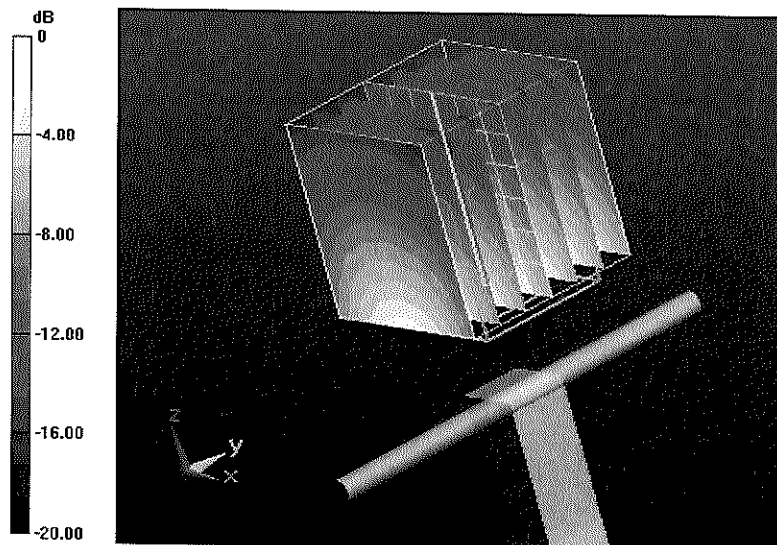

0 dB = 12.670mW/g = 22.06 dB mW/g

# Impedance Measurement Plot for Body TSL

6 Feb 2012 12:15:29

CH1 S11 1 U FS 4: 47.961  $\Omega$  6.6680  $\Omega$  558.55  $\mu$ H 1 900.000 000 MHz

\*  
De1  
Ca  
Avg  
15  
H1d

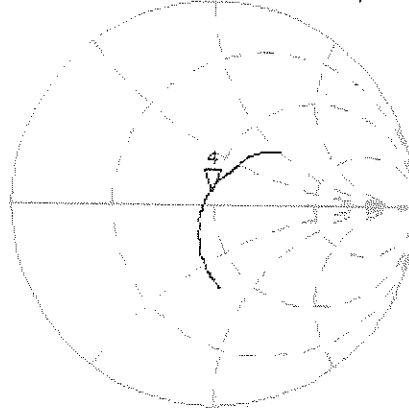

CH2 S11 LOG 5 dB/REF -20 dB 4:-22.971 dB 1 900.000 000 MHz

Ca  
Avg  
15  
H1d

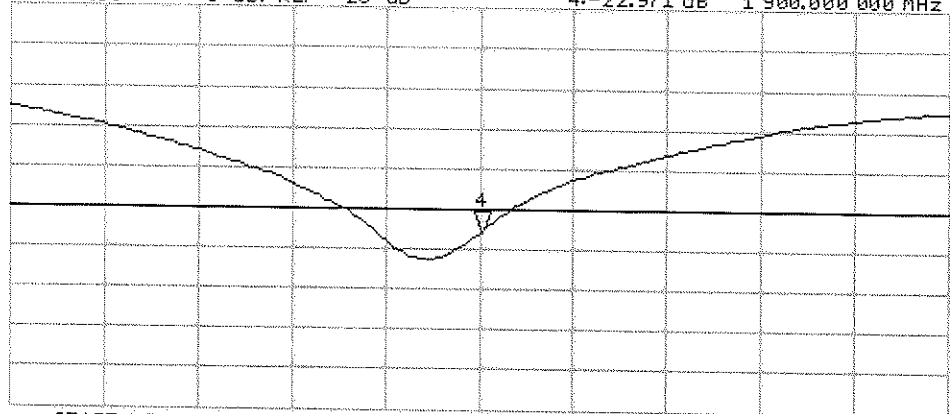

START 1 700.000 000 MHz

STOP 2 100.000 000 MHz