



FCC TEST REPORT

for

**Wireless Keyboard
MODEL: KB-887RF
Brand Name: NEWMEN**

**Test Report Number:
SZ100913B02-RP**

Issued for

**Shenzhen Fuyeda Industry Development Corp., Ltd
No.1, Newmen Road, Tongsheng Village, Dalang Street, BaoAn,
Shenzhen, China**

Issued by:

**COMPLIANCE CERTIFICATION SERVICES (SHENZHEN) INC.
No10-1, Mingkeda Logistics Park, No.18 Huanguan South RD. Guan lan Town,
Baoan District, Shenzhen China
TEL: 86-755-28055000
FAX: 86-755-28055221
Issued Date: September 18, 2010**



Note: *This report shall not be reproduced except in full, without the written approval of Compliance Certification Services Inc. This document may be altered or revised by Compliance Certification Services Inc. personnel only, and shall be noted in the revision section of the document. The client should not use it to claim product endorsement by TAF, A2LA, NVLAP, NIST or any government agencies. The test results in the report only apply to the tested sample.*



Revision History

Rev.	Issue No.	Revisions	Effect Page	Revised By
00	SZ100913B02-RP	Initial Issue	ALL	Vincent Yao



TABLE OF CONTENTS

1 TEST CERTIFICATION..... 4

2 EUT DESCRIPTION..... 5

3 TEST METHODOLOGY..... 6

3.1. DESCRIPTION OF TEST MODES 6

4 TEST METHODOLOGY..... 7

4.1. EUT EXERCISE..... 7

4.2. FCC PART 15.205 RESTRICTED BANDS OF OPERATIONS 7

5 INSTRUMENT CALIBRATION 8

6 SETUP OF EQUIPMENT UNDER TEST 8

6.1. DESCRIPTION OF SUPPORT UNITS..... 8

6.2. CONFIGURATION OF SYSTEM UNDER TEST 8

7 FACILITIES AND ACCREDITATIONS 9

7.1. FACILITIES..... 9

7.2. ACCREDITATIONS 9

7.3. MEASUREMENT UNCERTAINTY..... 9

8 FCC PART 15.249 REQUIREMENTS..... 10

8.1. BAND EDGES MEASUREMENT..... 10

8.2. POWER LINE CONDUCTED EMISSIONS MEASUREMENT 16

8.3. SPURIOUS EMISSIONS MEASUREMENT..... 19



1 TEST CERTIFICATION

Product:	Wireless Keyboard
Model:	KB-887RF
Brand:	NEWMEN
Tested:	September 13-18, 2010
Applicant:	Shenzhen Fuyeda Industry Development Corp., Ltd No.1, Newmen Road, Tongsheng Village, Dalang Street, BaoAn, Shenzhen, China
Manufacturer:	Shenzhen Fuyeda Industry Development Corp., Ltd No.1, Newmen Road, Tongsheng Village, Dalang Street, BaoAn, Shenzhen, China

APPLICABLE STANDARDS	
STANDARD	TEST RESULT
FCC 47 CFR Part 15 Subpart C	No non-compliance noted
DEVIATION FROM APPLICABLE STANDARD	
None	

We hereby certify that:

The above equipment was tested by Compliance Certification Services Inc. The test data, data evaluation, test procedures, and equipment configurations shown in this report were made in accordance with the procedures given in ANSI C63.4:2003 and the energy emitted by the sample EUT tested as described in this report is in compliance with the requirements of FCC Rules Part 15.207, 15.209, 15.249.

The test results of this report relate only to the tested sample EUT identified in this report.

Approved by:

Reviewed by:

Vincent Yao
Manager
Compliance Certification Service Inc.

Aven Zhou
Supervisor of Report Dept.
Compliance Certification Service Inc.



2 EUT DESCRIPTION

Product	Wireless Keyboard
Trade Name	NEWMEN
Model Number	KB-887RF
Model Discrepancy	N/A
Serial Number	SZ100913B02-RP
Power Supply	DC3V supplied by the battery (2*1.5V)
Frequency Range	2405-2476MHz
Transmit Power	Peak:82.24 dBuV/m (Max.) Average:82.17 dBuV/m (Max.)
Modulation Technique	GFSK
Number of Channels	64 Channels
Antenna Specification	Printed antenna with -0.97dBi gain (Max)

Note: 1. The sample selected for test was engineering sample that approximated to production product and was provided by manufacturer.

2. This submittal(s) (test report) is intended for FCC ID: V4P-KB887RF filing to comply with Section 15.207, 15.209 and 15.249 of the FCC Part 15, Subpart C Rules.



3 TEST METHODOLOGY

3.1. DESCRIPTION OF TEST MODES

The EUT had been tested under operating condition.

Test program used to control the EUT for staying in continuous transmitting and receiving mode is programmed.

The following test mode(s) were scanned during the preliminary test below 1G:

Test Item	Test mode	Worse mode
Conducted Emission	Not applicable since the EUT supplied by the battery.	
Radiated Emission	Mode 1: Normal Link	■

After verification, all tests were carried out with the worst case test modes as shown below except radiated spurious emission below 1GHz, which worst case was in normal link mode only.

Channel Low (2405MHz), Channel Mid (2439MHz) and Channel High (2476MHz) were chosen for the final testing.



4 TEST METHODOLOGY

The tests documented in this report were performed in accordance with ANSI C63.4:2003 and FCC CFR 15.209 and 15.249.

4.1. EUT EXERCISE

The EUT was operated in the engineering mode to fix the TX frequency that was for the purpose of the measurements.

According to its specifications, the EUT must comply with the requirements of the Section 15.109 under the FCC Rules Part 15 Subpart B and Section 15.209,15.249 under the FCC Rules Part 15 Subpart C.

4.2. FCC PART 15.205 RESTRICTED BANDS OF OPERATIONS

(a) Except as shown in paragraph (d) of this section, only spurious emissions are permitted in any of the frequency bands listed below:

MHz	MHz	MHz	GHz
0.090 - 0.110	16.42 - 16.423	399.9 - 410	4.5 - 5.15
¹ 0.495 - 0.505	16.69475 - 16.69525	608 - 614	5.35 - 5.46
2.1735 - 2.1905	16.80425 - 16.80475	960 - 1240	7.25 - 7.75
4.125 - 4.128	25.5 - 25.67	1300 - 1427	8.025 - 8.5
4.17725 - 4.17775	37.5 - 38.25	1435 - 1626.5	9.0 - 9.2
4.20725 - 4.20775	73 - 74.6	1645.5 - 1646.5	9.3 - 9.5
6.215 - 6.218	74.8 - 75.2	1660 - 1710	10.6 - 12.7
6.26775 - 6.26825	108 - 121.94	1718.8 - 1722.2	13.25 - 13.4
6.31175 - 6.31225	123 - 138	2200 - 2300	14.47 - 14.5
8.291 - 8.294	149.9 - 150.05	2310 - 2390	15.35 - 16.2
8.362 - 8.366	156.52475 -	2483.5 - 2500	17.7 - 21.4
8.37625 - 8.38675	156.52525	2655 - 2900	22.01 - 23.12
8.41425 - 8.41475	156.7 - 156.9	3260 - 3267	23.6 - 24.0
12.29 - 12.293	162.0125 - 167.17	3332 - 3339	31.2 - 31.8
12.51975 - 12.52025	167.72 - 173.2	3345.8 - 3358	36.43 - 36.5
12.57675 - 12.57725	240 - 285	3600 - 4400	(²)
13.36 - 13.41	322 - 335.4		

¹ Until February 1, 1999, this restricted band shall be 0.490-0.510 MHz.

² Above 38.6

(b) Except as provided in paragraphs (d) and (e), the field strength of emissions appearing within these frequency bands shall not exceed the limits shown in Section 15.209. At frequencies equal to or less than 1000 MHz, compliance with the limits in Section 15.209 shall be demonstrated using measurement instrumentation employing a CISPR quasi-peak detector. Above 1000 MHz, compliance with the emission limits in Section 15.209 shall be demonstrated based on the average value of the measured emissions. The provisions in Section 15.35 apply to these measurements.



5 INSTRUMENT CALIBRATION

The measuring equipment, which was utilized in performing the tests documented herein, has been calibrated in accordance with the manufacturer's recommendations for utilizing calibration equipment, which is traceable to recognized national standards.

6 SETUP OF EQUIPMENT UNDER TEST

6.1. DESCRIPTION OF SUPPORT UNITS

The EUT has been tested as an independent unit together with other necessary accessories or support units. The following support units or accessories were used to form a representative test configuration during the tests.

No.	Device Type	Brand	Model	Serial No.	FCC ID	Data Cable	Power Cord
1	Notebook	IBM	2672	992F2VG	DoC	N/A	Unshielded 1.80m
2	Dongle	NEWMEN	N/A	N/A	N/A	N/A	N/A

Note:

- 1) All the equipment/cables were placed in the worst-case configuration to maximize the emission during the test.
- 2) Grounding was established in accordance with the manufacturer's requirements and conditions for the intended use.

6.2. CONFIGURATION OF SYSTEM UNDER TEST

See test photographs attached in Appendix II for the actual connections between EUT and support equipment.



7 FACILITIES AND ACCREDITATIONS

7.1. FACILITIES

All measurement facilities used to collect the measurement data are located at
 No10-1, Mingkeda Logistics Park, No.18 Huanguan South RD. Guan lan Town, Baoan District, Shenzhen China

The sites are constructed in conformance with the requirements of ANSI C63.4:2003, ANSI C63.7 and CISPR Publication 22. All receiving equipment conforms to CISPR Publication 16-1, "Radio Interference Measuring Apparatus and Measurement Methods."

7.2. ACCREDITATIONS

Our laboratories are accredited and approved by the following accreditation body according to ISO/IEC 17025.

Taiwan	TAF
USA	A2LA

The measuring facility of laboratories has been authorized or registered by the following approval agencies.

USA	FCC
Japan	VCCI
Canada	INDUSTRY CANADA
Taiwan	BSMI
Norway	Nemko

Copies of granted accreditation certificates are available for downloading from our web site, <http://www.ccsrf.com>

7.3. MEASUREMENT UNCERTAINTY

Where relevant, the following measurement uncertainty levels have been estimated for tests performed on the EUT as specified in CISPR 16-4-2:

Measurement	Frequency	Uncertainty
Conducted emissions	9kHz~30MHz	+/- 3.18dB
Radiated emissions	30MHz ~ 200MHz	+/- 3.79dB
	200MHz ~1000MHz	+/- 3.62dB

This uncertainty represents an expanded uncertainty expressed at approximately the 95% confidence level using a coverage factor of k=2.

The measured result is above (below) the specification limit by a margin less than the measurement uncertainty; it is therefore not possible to state compliance based on the 95% level of confidence. However, the result indicates that compliance (non-compliance) is more probable than non-compliance) with the specification limit.



8 FCC PART 15.249 REQUIREMENTS

8.1. BAND EDGES MEASUREMENT

LIMIT

1. In the above emission table, the tighter limit applies at the band edges.

Frequency (Hz)	Field Strength ($\mu\text{V}/\text{m}$ at 3-meter)	Field Strength ($\text{dB}\mu\text{V}/\text{m}$ at 3-meter)
30-88	100	40
88-216	150	43.5
216-960	200	46
Above 960	500	54

- As shown in Section 15.35(b), for frequencies above 1000 MHz, the above field strength limits in paragraphs (a) and (b) of this section are based on average limits. However, the peak field strength of any emission shall not exceed the maximum permitted average limits specified above by more than 20 dB under any condition of modulation. For point-to-point operation under paragraph (b) of this section, the peak field strength shall not exceed 2500 millivolts/meter at 3 meters along the antenna azimuth.
- As shown in Section 15.249(d) Emissions radiated outside of the specified frequency bands, except for harmonics, shall be attenuated by at least 50 dB below the level of the fundamental or to the general radiated emission limits in Section 15.209, whichever is the lesser attenuation.

MEASUREMENT EQUIPMENT USED

Radiated Emission Test Site 966 (2)					
Name of Equipment	Manufacturer	Model Number	Serial Number	Last Calibration	Due Calibration
PSA Series Spectrum Analyzer	Agilent	E4446A	US44300399	03/21/2010	03/21/2011
Amplifier	MITEQ	AM-1604-3000	1411843	03/21/2010	03/21/2011
Turn Table	EMCO	2081-1.21	N/A	N.C.R	N.C.R
Controller	CT	N/A	N/A	N.C.R	N.C.R
High Noise Amplifier	Agilent	8449B	3008A01838	06/18/2010	06/18/2011
Site NSA	C&C	N/A	N/A	N.C.R	N.C.R
Bilog Antenna	SCHAFFNER	CBL6143	5082	06/18/2010	06/18/2011
Horn Antenna	SCHWARZBECK	BBHA9120D	D286	03/19/2010	03/19/2011
Signal Generator	Anritsu	MG3694A	#050125	03/21/2010	03/21/2011
Horn Antenna	TRC	HA0301	N/A	03/19/2010	03/19/2011
Loop Antenna	A.R.A	PLA-1030/B	1029	03/19/2010	03/19/2011
Power Sensor	Anritsu	MA2491A	030619	06/18/2010	06/18/2011
Power Meter	Anritsu	ML2487A	6K00001491	06/18/2010	06/18/2011
Temp. / Humidity Meter	VICTOR	VC230	N/A	03/30/2010	03/30/2011

Remark: Each piece of equipment is scheduled for calibration once a year.



Test Configuration

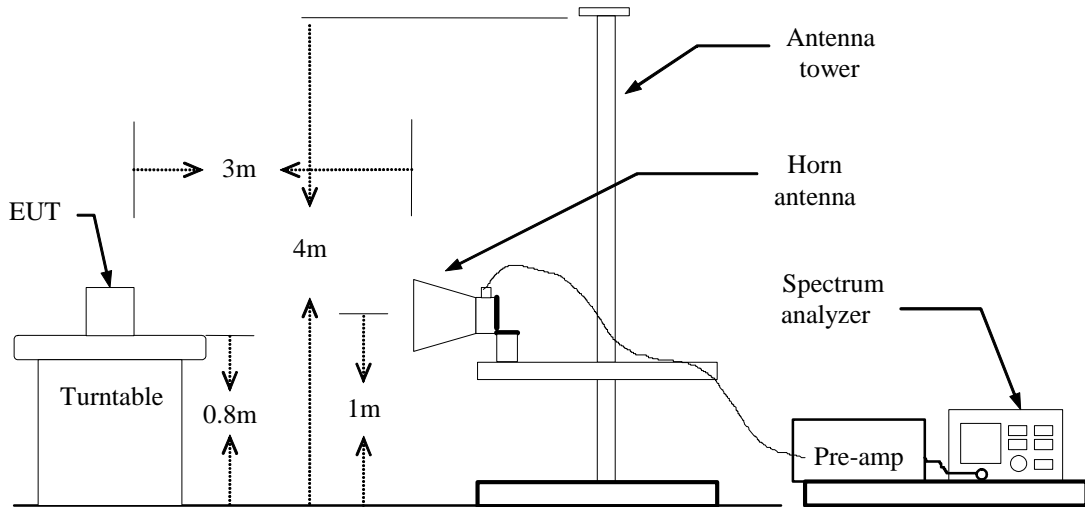

TEST PROCEDURE

1. The EUT is placed on a turntable, which is 0.8m above the ground plane.
2. The turntable shall be rotated for 360 degrees to determine the position of maximum emission level.
3. EUT is set 3m away from the receiving antenna, which is varied from 1m to 4m to find out the highest emission.
4. Set the spectrum analyzer in the following setting in order to capture the lower and upper band-edges of the emission:
 - (a) PEAK: RBW=VBW=1MHz / Sweep=AUTO
 - (b) AVERAGE: RBW=1MHz / VBW=10Hz / Sweep=AUTO
5. Repeat the procedures until all the PEAK and AVERAGE versus POLARIZATION are measured.

TEST RESULTS

Refer to attach spectrum analyzer data chart.



Test Data

Band Edges (CH-Low)

Detector mode: Peak

Polarity: Vertical

Agilent 14:07:09 Sep 17, 2010

R T

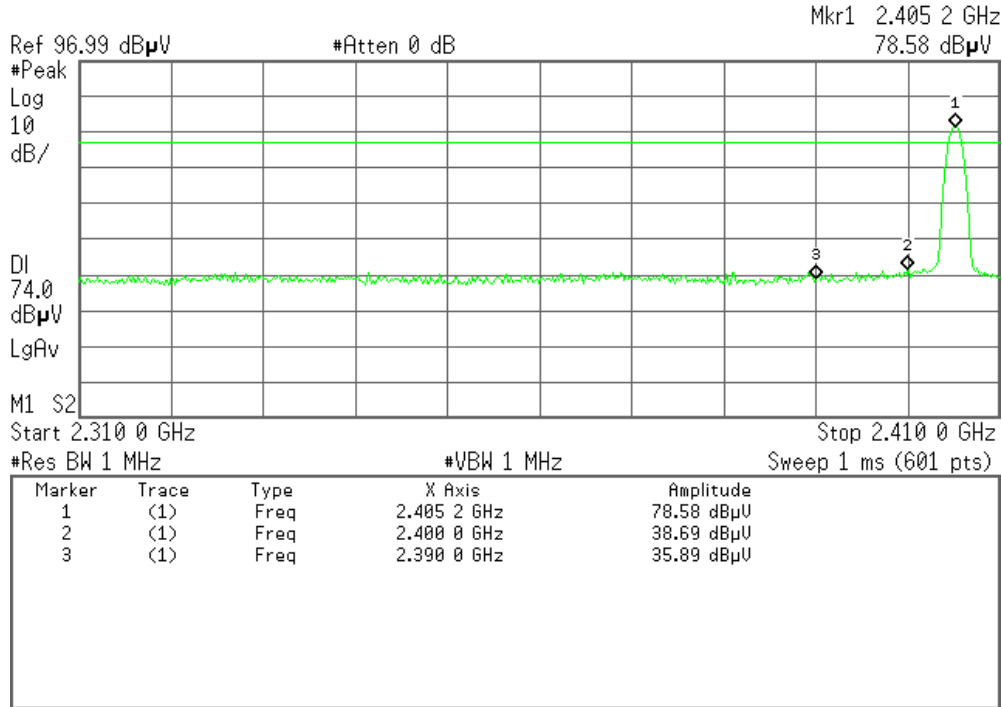

Detector mode: Average

Polarity: Vertical

Agilent 14:07:38 Sep 17, 2010

R T

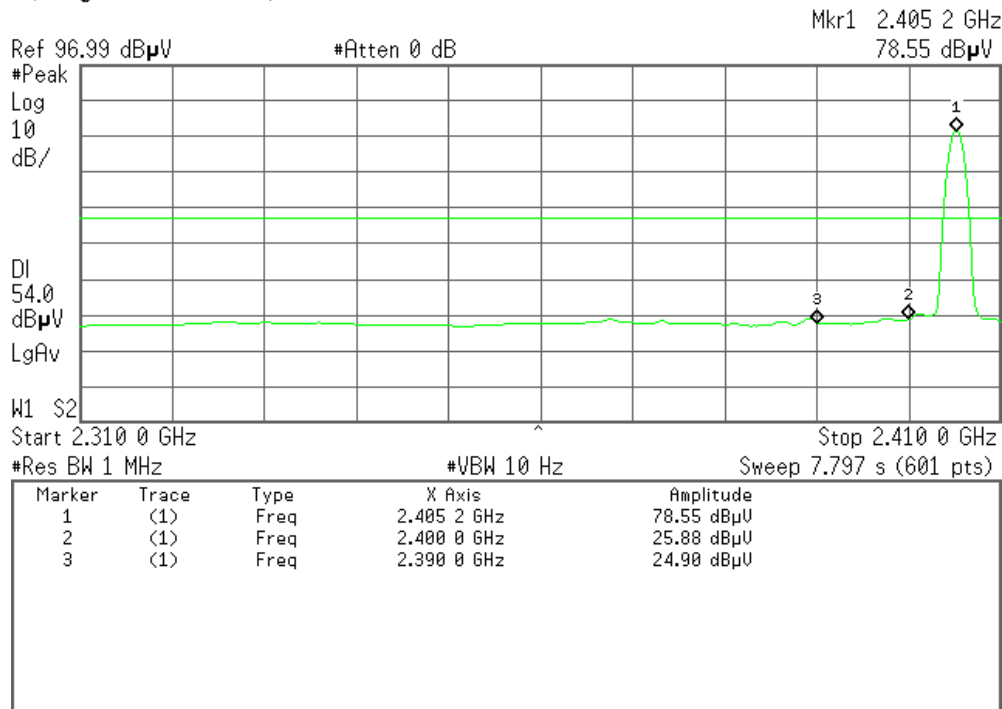



Detector mode: Peak

Polarity: Horizontal

Agilent 13:58:23 Sep 17, 2010

R T

Mkr1 2.405 2 GHz
77.09 dBμV

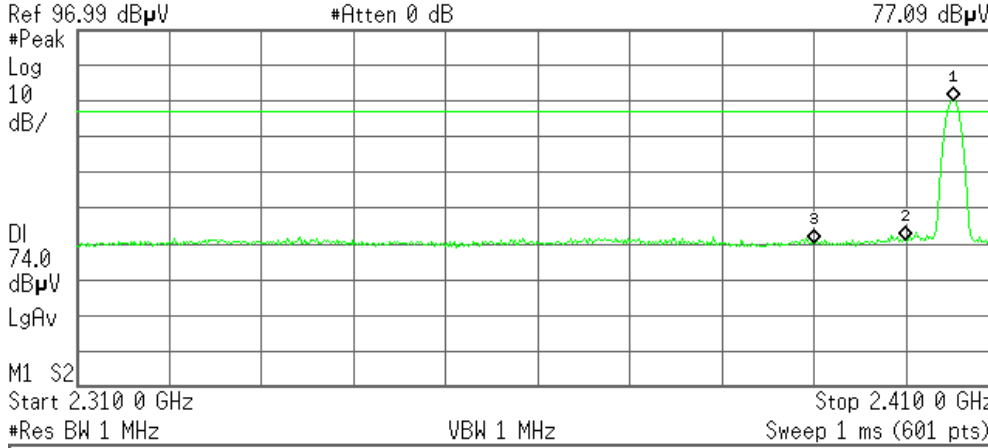

Marker	Trace	Type	X Axis	Amplitude
1	(1)	Freq	2.405 2 GHz	77.09 dBμV
2	(1)	Freq	2.400 0 GHz	38.07 dBμV
3	(1)	Freq	2.390 0 GHz	37.16 dBμV

Detector mode: Average

Polarity: Horizontal

Agilent 13:59:01 Sep 17, 2010

R T

Mkr1 2.405 2 GHz
77.023 dBμV

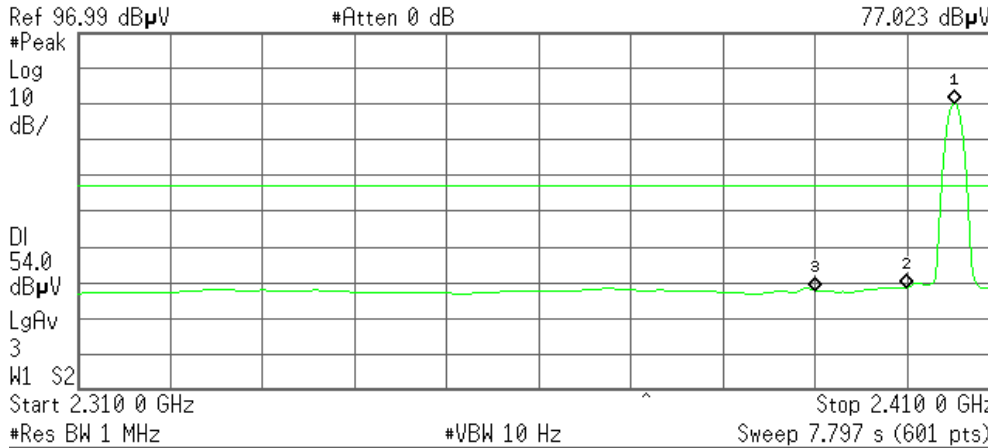

Marker	Trace	Type	X Axis	Amplitude
1	(1)	Freq	2.405 2 GHz	77.02 dBμV
2	(1)	Freq	2.400 0 GHz	25.73 dBμV
3	(1)	Freq	2.390 0 GHz	24.73 dBμV



Band Edges (CH-High)

Detector mode: Peak

Polarity: Vertical

Agilent 14:05:49 Sep 17, 2010

R T

Mkr2 2.483 50 GHz
35.83 dBμV

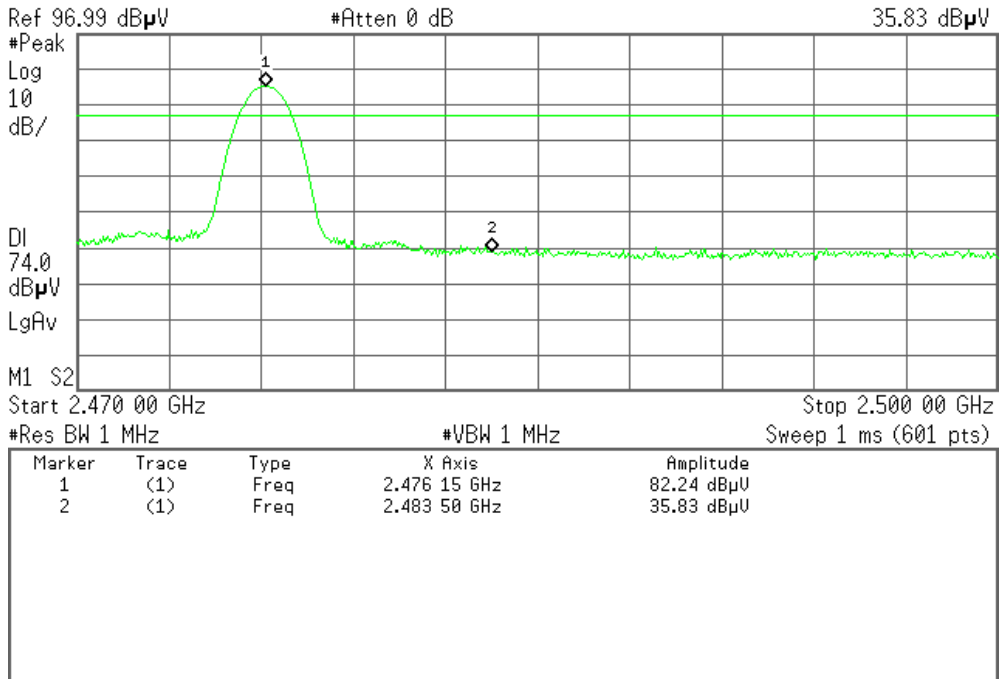

Detector mode: Average

Polarity: Vertical

Agilent 14:05:12 Sep 17, 2010

R T

Mkr2 2.483 50 GHz
25.04 dBμV

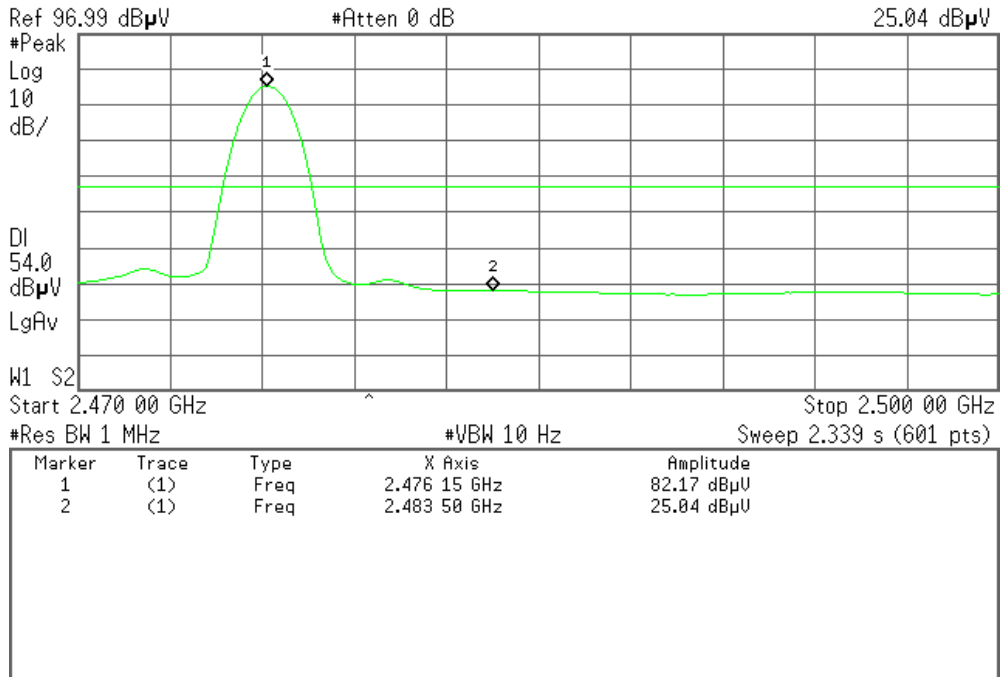



Detector mode: Peak

Polarity: Horizontal

Agilent 14:01:20 Sep 17, 2010

R T

Mkr2 2.483 50 GHz
36.70 dBμV

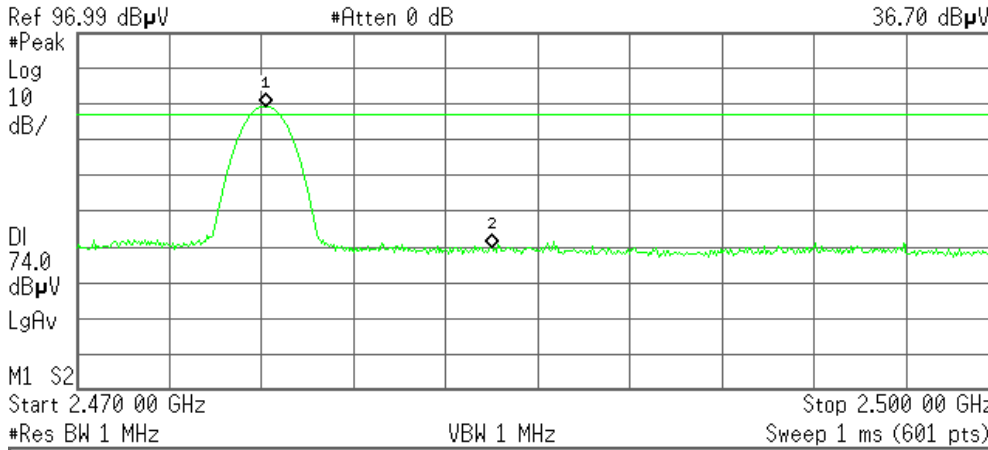

Marker	Trace	Type	X Axis	Amplitude
1	(1)	Freq	2.476 15 GHz	76.40 dBμU
2	(1)	Freq	2.483 50 GHz	36.70 dBμU

Detector mode: Average

Polarity: Horizontal

Agilent 14:01:44 Sep 17, 2010

R T

Mkr2 2.483 50 GHz
24.79 dBμV

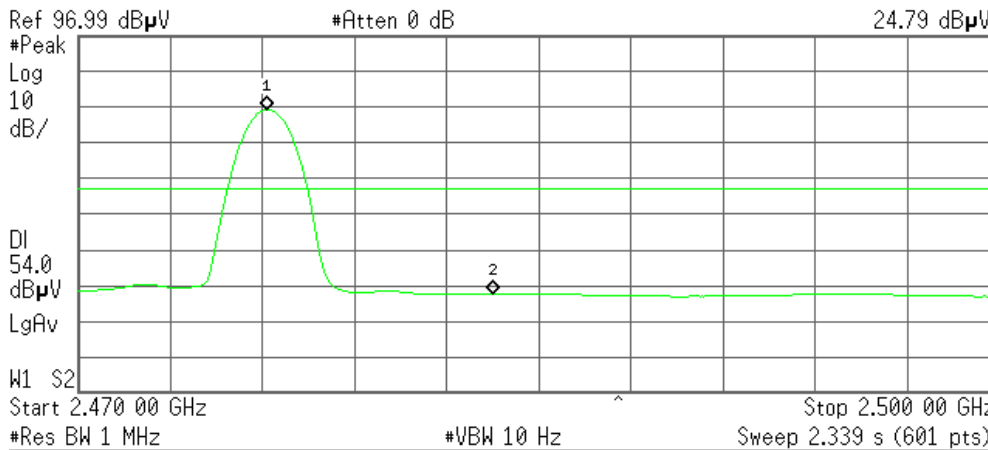

Marker	Trace	Type	X Axis	Amplitude
1	(1)	Freq	2.476 15 GHz	76.20 dBμU
2	(1)	Freq	2.483 50 GHz	24.79 dBμU



8.2. POWER LINE CONDUCTED EMISSIONS MEASUREMENT

8.2.1. LIMITS OF CONDUCTED EMISSIONS MEASUREMENT

According to §15.207(a), except as shown in paragraphs (b) and (c) of this section, for an intentional radiator that is designed to be connected to the public utility (AC) power line, the radio frequency voltage that is conducted back onto the AC power line on any frequency or frequencies within the band 150 kHz to 30 MHz shall not exceed the limits in the following table, as measured using a 50 μH/50 ohms line impedance stabilization network (LISN). Compliance with the provisions of this paragraph shall be based on the measurement of the radio frequency voltage between each power line and ground at the power terminal. The lower limit applies at the boundary between the frequency ranges.

Frequency Range (MHz)	Limits (dBμV)	
	Quasi-peak	Average
0.15 to 0.50	66 to 56*	56 to 46*
0.50 to 5	56	46
5 to 30	60	50

NOTE:

- (1) The lower limit shall apply at the transition frequencies.
- (2) The limit decreases in line with the logarithm of the frequency in the range of 0.15 to 0.50 MHz.
- (3) All emanations from a class A/B digital device or system, including any network of conductors and apparatus connected thereto, shall not exceed the level of field strengths specified above.

8.2.2. TEST INSTRUMENTS

Conducted Emission Test Site					
Name of Equipment	Manufacturer	Model Number	Serial Number	Last Calibration	Due Calibration
ESCI EMI TEST RECEIVE.ESCI	ROHDE&SCHWARZ	ESCI	100783	03/21/2010	03/21/2011
Attenuator	SCHAFFNER	CFL9206	1711	07/14/2010	07/14/2011
LISN	SCHAFFNER	NNB42	2001/001	05/26/2010	05/26/2011
LISN	EMCO	3825/2	8901-1459	03/21/2010	03/21/2011
ISN	FCC	FCC-TILISN-T4	20182	03/21/2010	03/21/2011
ISN	FCC	FCC-TLISN-T8-02	20183	03/21/2010	03/21/2011
ISN	FCC	FCC-TLISN-T4-02	20382	03/21/2010	03/21/2011
ISN	FCC	FCC-TLISN-T4-02	20383	03/21/2010	03/21/2011
ISN	FCC	FCC-801-T8-RJ45	04030	03/21/2010	03/21/2011
Current Probe	STODDART AIRCRAFT	91550-1	345-73	03/21/2010	03/21/2011
Temp. / Humidity Meter	VICTOR	VC230	N/A	03/30/2010	03/30/2011

- NOTE:** 1. The calibration interval of the above test instruments is 12 months and the calibrations are traceable to NML/ROC and NIST/USA.
2. N.C.R = No Calibration Request.



8.2.3. TEST PROCEDURES (please refer to measurement standard)

- The EUT and Support equipment, if needed, was placed on a non-conducted table, which is 0.8m above the ground plane and 0.4m away from the conducted wall.
- The test equipment EUT installed received AC main power, through a Line Impedance Stabilization Network (LISN), which supplied power source and was grounded to the ground plane. All support equipment power received from a second LISN. The two LISNs provide 50 ohm/ 50uH of coupling impedance for the measuring instrument.
- The EUT test program was started. Emissions were measured on each current carrying line of the EUT using an EMI Test Receiver connected to the LISN powering the EUT.
- The frequency range from 150 kHz to 30 MHz was searched. The test data of the worst-case condition(s) was recorded. Emission levels under limit 20dB were not recorded.



8.2.4. TEST SETUP

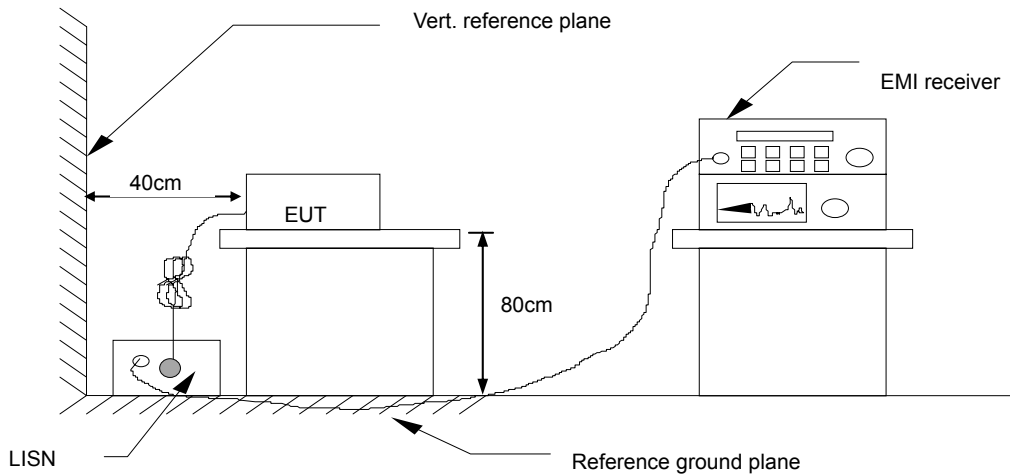

- For the actual test configuration, please refer to the related item – Photographs of the Test Configuration.

8.2.5. Data Sample:

Freq. (MHz)	Q.P. Level (dBuV)	AVG Level (dBuV)	Cor. Factor (dB)	Q.P. Result (dBuV)	AVG Result (dBuV)	Q.P. Limit (dBuV)	AVG Limit (dBuV)	Q.P. Margin (dB)	AVG Margin (dB)	Line (L1/L2)
xx.xx	37.86	32.92	11.52	49.38	44.44	60.41	50.41	-11.03	-5.97	L1

- Freq. = Emission frequency in MHz
- Level = Uncorrected Analyzer/Receiver reading
- Factor = Insertion loss of LISN + Cable Loss
- Result = Level+ Factor
- Limit = Limit stated in standard
- Margin = Reading in reference to limit
- P = Peak Reading
- Q.P = Quasi-peak Reading
- AVG = Average Reading
- L1 = Hot side
- L2 = Neutral side

Calculation Formula

Margin (dB) = Result (dBuV) – Limit (dBuV)

8.2.6. TEST RESULTS

Not applicable, since the EUT is powered by the battery.



8.3. SPURIOUS EMISSIONS MEASUREMENT

8.3.1. LIMITS OF RADIATED EMISSIONS MEASUREMENT

1. In the section 15.249(a):

Except as provided in paragraph (b) of this section, the field strength of emissions from intentional radiators operated within these frequency bands shall comply with the following:

Fundamental Frequency	Field Strength of Fundamental Field Strength (mV/m)	Field Strength of Harmonics (μ V/m)
902-928 MHz	50	500
2400 - 2483.5 MHz	50	500
5725 - 5875 MHz	50	500
24.0 - 24.25 GHz	250	2500

2. Except as provided elsewhere in this Subpart, the emissions from an intentional radiator shall not exceed the field strength levels specified in the following table:

Frequency (MHz)	Field Strength (μ V/m)	Measurement Distance (m)
0.009-0.490	2400/F(kHz)	300
0.490-1.705	24000/F(kHz)	30
1.705-30.0	30	30
30-88	100*	3
88-216	150*	3
216-960	200*	3
Above 960	500	3

Remark: Except as provided in paragraph (g), fundamental emissions from intentional radiators operating under this Section shall not be located in the frequency bands 54-72 MHz, 76-88 MHz, 174-216 MHz or 470-806 MHz. However, operation within these frequency bands is permitted under other sections of this Part, e.g., Sections 15.231 and 15.241.

3. In the above emission table, the tighter limit applies at the band edges.

Frequency (Hz)	Field Strength (μ V/m at 3-meter)	Field Strength (dB μ V/m at 3-meter)
30-88	100	40
88-216	150	43.5
216-960	200	46
Above 960	500	54



8.3.2. TEST INSTRUMENTS

Radiated Emission Test Site 966 (2)					
Name of Equipment	Manufacturer	Model Number	Serial Number	Last Calibration	Due Calibration
PSA Series Spectrum Analyzer	Agilent	E4446A	US44300399	03/21/2010	03/21/2011
Amplifier	MITEQ	AM-1604-3000	1411843	03/21/2010	03/21/2011
Turn Table	EMCO	2081-1.21	N/A	N.C.R	N.C.R
Controller	CT	N/A	N/A	N.C.R	N.C.R
High Noise Amplifier	Agilent	8449B	3008A01838	06/18/2010	06/18/2011
Site NSA	C&C	N/A	N/A	N.C.R	N.C.R
Bilog Antenna	SCHAFFNER	CBL6143	5082	06/18/2010	06/18/2011
Horn Antenna	SCHWARZBECK	BBHA9120D	D286	03/19/2010	03/19/2011
Signal Generator	Anritsu	MG3694A	#050125	03/21/2010	03/21/2011
Horn Antenna	TRC	HA0301	N/A	03/19/2010	03/19/2011
Loop Antenna	A.R.A	PLA-1030/B	1029	03/19/2010	03/19/2011
Power Sensor	Anritsu	MA2491A	030619	06/18/2010	06/18/2011
Power Meter	Anritsu	ML2487A	6K00001491	06/18/2010	06/18/2011
Temp. / Humidity Meter	VICTOR	VC230	N/A	03/30/2010	03/30/2011

- NOTE:** 1. The calibration interval of the above test instruments is 12 months and the calibrations are traceable to NML/ROC and NIST/USA.
2. The FCC Site Registration number is 101879.
4. N.C.R = No Calibration Required.

8.3.3 TEST PROCEDURE (please refer to measurement standard)

- The EUT is placed on a turntable, which is 0.8m above ground plane.
- The turntable shall be rotated for 360 degrees to determine the position of maximum emission level.
- EUT is set 3m away from the receiving antenna, which is varied from 1m to 4m to find out the highest emissions.
- Maximum procedure was performed on the six highest emissions to ensure EUT compliance.
- And also, each emission was to be maximized by changing the polarization of receiving antenna both horizontal and vertical.
- Set the spectrum analyzer in the following setting as:
Below 1GHz:
RBW=100kHz / VBW=300kHz / Sweep=AUTO
Above 1GHz:
(a) PEAK: RBW=VBW=1MHz / Sweep=AUTO
(b) AVERAGE: RBW=1MHz / VBW=10Hz / Sweep=AUTO
- Repeat above procedures until the measurements for all frequencies are complete.



8.3.2.1. TEST SETUP

Below 30MHz

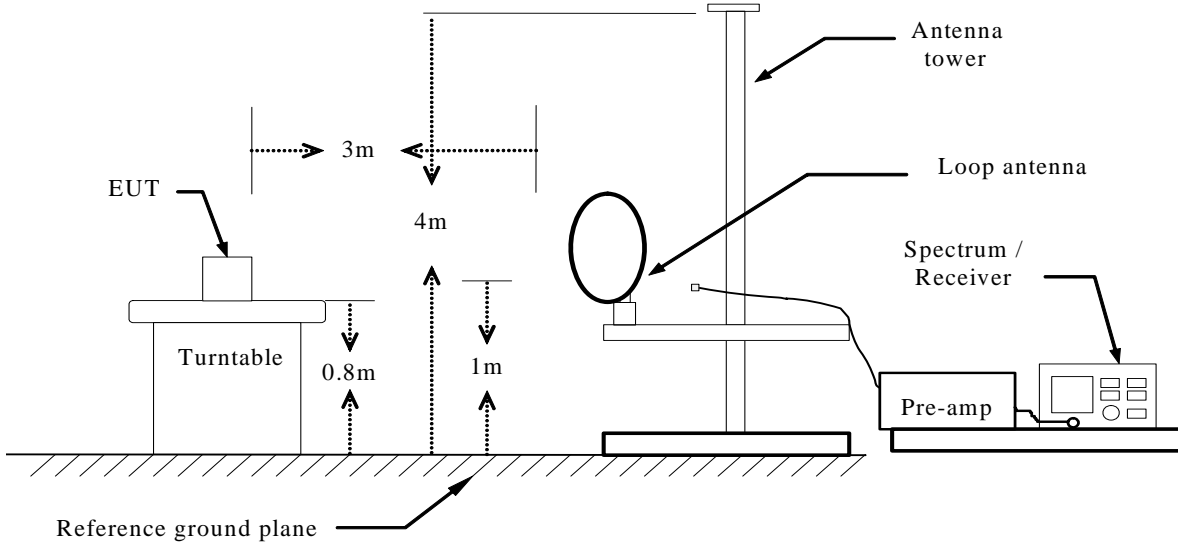

Below 1 GHz

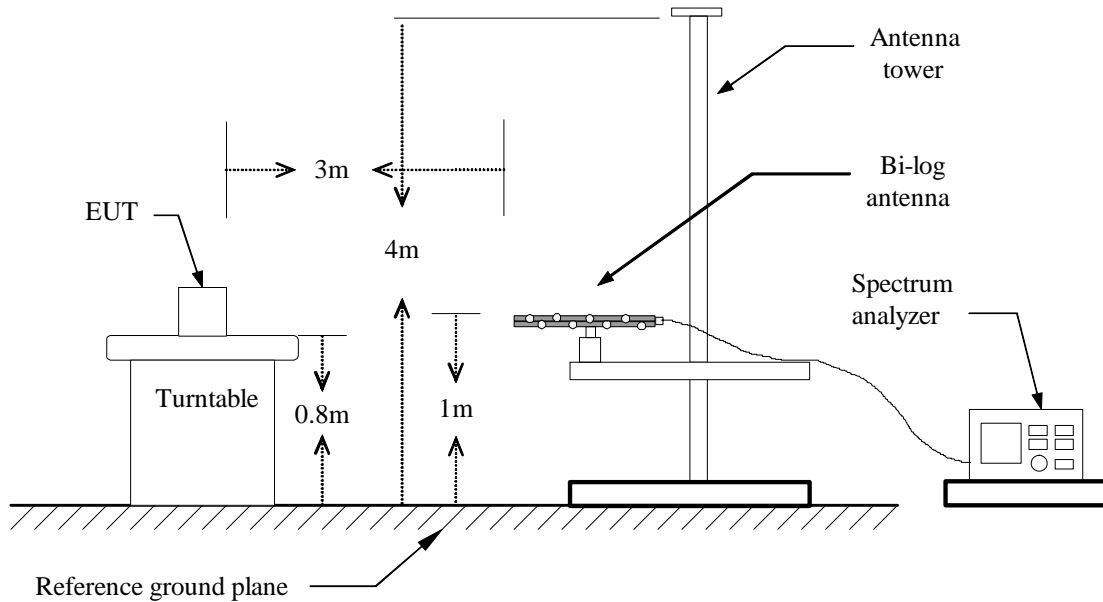



Above 1 GHz

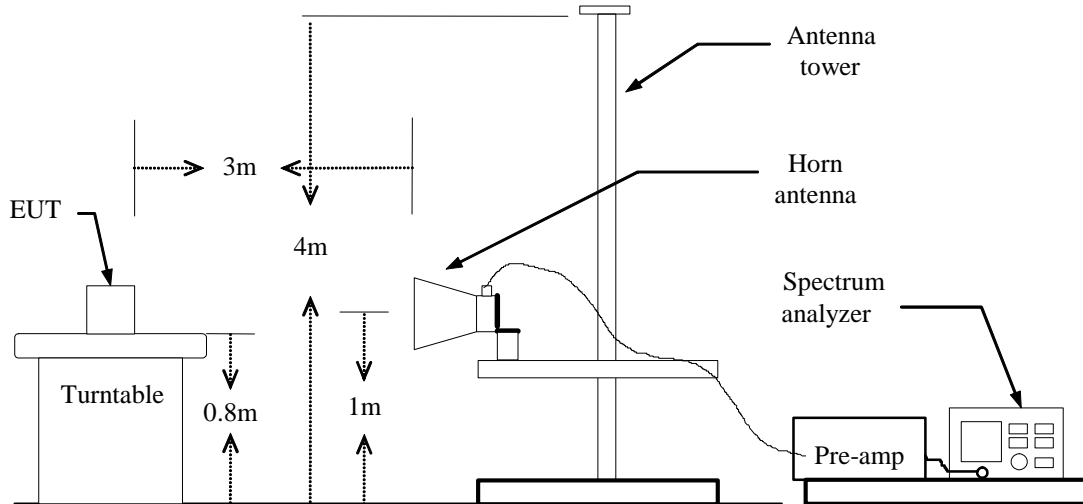

For the actual test configuration, please refer to the related item – Photographs of the Test Configuration.

8.3.2.2. Data Sample:

Below 1 GHz

Frequency (MHz)	Ant.Pol. (H/V)	Reading (Remark) (dBuV)	Correction Factor (dB/m)	Result (Remark) (dBuV/m)	Limit (Peak) (dBuV/m)	Margin (dB)	Remark
xxx	V	12.12	10.21	22.33	40.00	-17.67	Peak

Above 1 GHz

Frequency (MHz)	Ant.Pol. (H/V)	Reading (Peak) (dBuV)	Reading (Average) (dBuV)	Correction Factor (dB/m)	Result (Peak) (dBuV/m)	Result (Average) (dBuV/m)	Limit (Peak) (dBuV/m)	Limit (Average) (dBuV/m)	Margin (dB)	Remark
xxx	V	65.45	63.00	-11.12	54.33	51.88	74.00	54.00	-2.12	AVG

- Frequency (MHz) = Emission frequency in MHz
- Ant.Pol. (H/V) = Antenna polarization
- Reading (dBuV) = Uncorrected Analyzer / Receiver reading
- Correction Factor (dB/m) = Antenna factor + Cable loss – Amplifier gain
- Result (dBuV/m) = Reading (dBuV) + Correction Factor (dB/m)
- Limit (dBuV/m) = Limit stated in standard
- Margin (dB) = Remark Result (dBuV/m) – Limit (dBuV/m)
- Peak = Peak Reading
- QP = Quasi-peak Reading
- AVG = Average Reading



8.3.2.3. TEST RESULTS

Below 1 GHz

Operation Mode: Normal Link

Test Date: September 16, 2010

Temperature: 24.2°C

Tested by: Tom Gan

Humidity: 53 % RH

Polarity: Ver. / Hor.

Freq. (MHz)	Ant.Pol. H/V	Detector Mode (PK/QP)	Reading (dBuV)	Factor (dB)	Actual FS (dBuV/m)	Limit 3m (dBuV/m)	Safe Margin (dB)
33.233	V	Peak	41.07	-13.06	28.01	40.00	-11.99
115.683	V	Peak	41.69	-20.66	21.03	43.50	-22.47
159.333	V	Peak	38.26	-22.11	16.15	43.50	-27.35
227.333	V	Peak	34.36	-20.56	13.80	46.00	-32.20
615.233	V	Peak	32.98	-12.21	20.77	46.00	-25.23
940.183	V	Peak	32.82	-8.97	23.85	46.00	-22.15
33.233	H	Peak	40.95	-13.06	27.89	40.00	-12.11
39.700	H	Peak	35.30	-16.22	19.08	40.00	-20.92
115.683	H	Peak	40.00	-20.66	19.34	43.50	-24.16
159.333	H	Peak	36.21	-22.11	14.10	43.50	-29.40
220.766	H	Peak	33.34	-20.01	13.33	46.00	-32.67
670.200	H	Peak	33.66	-11.96	21.70	46.00	-24.30

****Remark:** No emission found between lowest internal used/generated frequency to 30 MHz.

REMARKS:

1. Measuring frequencies from 30 MHz to the 1GHz.
2. Radiated emissions measured in frequency range from 30 MHz to 1000MHz were made with an instrument using peak/quasi-peak detector mode.
3. Quasi-peak test would be performed if the peak result were greater than the quasi-peak limit or as required by the applicant.
4. Measurements above show only up to 6 maximum emissions noted, or would be lesser, with " N/A " remark, if no specific emissions from the EUT are recorded (ie: margin>20dB from the applicable limit) and considered that's already beyond the background noise floor.
5. Margin (dB) = Remark result (dBuV/m) – Quasi-peak limit (dBuV/m).



Above 1 GHz

Operation Mode: TX / CH Low

Test Date: September 16, 2010

Temperature: 24.2°C

Tested by: Tom Gan

Humidity: 53 % RH

Polarity: Ver. / Hor.

Fundamental

Freq. (MHz)	Ant. Pol H/V	Peak Reading (dBuV)	AV Reading (dBuV)	Ant. / CL CF (dB)	Actual Fs		Peak Limit (dBuV/m)	AV Limit (dBuV/m)	Peak Margin (dB)	AV Margin (dB)
					Peak (dBuV/m)	AV (dBuV/m)				
2405	V	88.29	88.26	-9.71	78.58	78.55	114	94	-35.42	-15.45
2405	H	86.8	86.73	-9.71	77.09	77.02	114	94	-36.91	-16.98

Freq. (MHz)	Ant. Pol H/V	Peak Reading (dBuV)	AV Reading (dBuV)	Ant. / CL CF (dB)	Actual Fs		Peak Limit (dBuV/m)	AV Limit (dBuV/m)	Margin (dB)	Remark
					Peak (dBuV/m)	AV (dBuV/m)				
4815.00	V	60.16	44.17	-0.60	59.56	43.57	74.00	54.00	-10.43	AVG.
6226.66	V	45.94	---	3.80	49.74	---	74.00	54.00	-4.26	Peak
7218.33	V	46.21	---	5.02	51.23	---	74.00	54.00	-2.77	Peak
7801.66	V	46.73	---	6.06	52.79	---	74.00	54.00	-1.21	Peak
N/A										
2855.00	H	47.66	---	-6.95	40.71	---	74.00	54.00	-13.29	Peak
3648.33	H	46.46	---	-3.82	42.64	---	74.00	54.00	-11.36	Peak
5760.00	H	45.54	---	2.37	47.91	---	74.00	54.00	-6.09	Peak
7416.66	H	44.97	---	5.50	50.47	---	74.00	54.00	-3.53	Peak

REMARKS:

1. Measuring frequencies from 1 GHz to the 10th harmonic of highest fundamental frequency.
2. Radiated emissions measured in frequency above 1000MHz were made with an instrument using peak/average detector mode.
3. Average test would be performed if the peak result were greater than the average limit or as required by the applicant.
4. Data of measurement within this frequency range shown " --- " in the table above means the reading of emissions are attenuated more than 20dB below the permissible limits or the field strength is too small to be measured.
5. Measurements above show only up to 6 maximum emissions noted, or would be lesser, with " N/A " remark, if no specific emissions from the EUT are recorded (ie: margin>20dB from the applicable limit) and considered that's already beyond the background noise floor.
6. Margin (dB) = Remark result (dBuV/m) – Average limit (dBuV/m).



Operation Mode: TX / CH Mid
Temperature: 24.2°C
Humidity: 53 % RH

Test Date: September 16, 2010
Tested by: Tom Gan
Polarity: Ver. / Hor.

Fundamental

Freq. (MHz)	Ant. Pol H/V	Peak Reading (dBuV)	AV Reading (dBuV)	Ant. / CL CF (dB)	Actual Fs		Peak Limit (dBuV/m)	AV Limit (dBuV/m)	Peak Margin (dB)	AV Margin (dB)
					Peak (dBuV/m)	AV (dBuV/m)				
2439	V	91.99	91.76	-9.75	82.24	82.01	114	94	-31.76	-11.99
2439	H	86.58	86.29	-9.75	76.83	76.54	114	94	-37.17	-17.46

Freq. (MHz)	Ant. Pol H/V	Peak Reading (dBuV)	AV Reading (dBuV)	Ant. / CL CF (dB)	Actual Fs		Peak Limit (dBuV/m)	AV Limit (dBuV/m)	Margin (dB)	Remark
					Peak (dBuV/m)	AV (dBuV/m)				
4021.66	V	46.10	---	-3.50	42.60	---	74.00	54.00	-11.40	Peak
4873.33	V	61.55	43.69	-0.42	61.13	43.27	74.00	54.00	-10.73	AVG.
6226.66	V	45.07	---	3.80	48.87	---	74.00	54.00	-5.13	Peak
7230.00	V	46.23	---	5.05	51.28	---	74.00	54.00	-2.72	Peak
N/A										
2785.00	H	47.99	---	-7.42	40.57	---	74.00	54.00	-13.43	Peak
4873.33	H	47.67	---	-0.42	47.25	---	74.00	54.00	-6.75	Peak
6226.66	H	45.83	---	3.80	49.63	---	74.00	54.00	-4.37	Peak
7136.66	H	46.28	---	4.79	51.07	---	74.00	54.00	-2.93	Peak
N/A										

REMARKS:

1. Measuring frequencies from 1 GHz to the 10th harmonic of highest fundamental frequency.
2. Radiated emissions measured in frequency above 1000MHz were made with an instrument using peak/average detector mode.
3. Average test would be performed if the peak result were greater than the average limit or as required by the applicant.
4. Data of measurement within this frequency range shown " --- " in the table above means the reading of emissions are attenuated more than 20dB below the permissible limits or the field strength is too small to be measured.
5. Measurements above show only up to 6 maximum emissions noted, or would be lesser, with " N/A " remark, if no specific emissions from the EUT are recorded (ie: margin>20dB from the applicable limit) and considered that's already beyond the background noise floor.
6. Margin (dB) = Remark result (dBuV/m) – Average limit (dBuV/m).



Operation Mode: TX / CH High
Temperature: 24.2°C
Humidity: 53 % RH

Test Date: September 16, 2010
Tested by: Tom Gan
Polarity: Ver. / Hor.

Fundamental

Freq. (MHz)	Ant. Pol H/V	Peak Reading (dBuV)	AV Reading (dBuV)	Ant. / CL CF (dB)	Actual Fs		Peak Limit (dBuV/m)	AV Limit (dBuV/m)	Peak Margin (dB)	AV Margin (dB)
					Peak (dBuV/m)	AV (dBuV/m)				
2476	V	92.02	91.95	-9.78	82.24	82.17	114	94	-31.76	-11.83
2476	H	86.18	85.98	-9.78	76.40	76.20	114	94	-37.60	-17.80

Freq. (MHz)	Ant. Pol H/V	Peak Reading (dBuV)	AV Reading (dBuV)	Ant. / CL CF (dB)	Actual Fs		Peak Limit (dBuV/m)	AV Limit (dBuV/m)	Margin (dB)	Remark
					Peak (dBuV/m)	AV (dBuV/m)				
3613.33	V	47.01	---	-3.81	43.20	---	74.00	54.00	-10.80	Peak
4955.00	V	59.63	45.53	-0.15	59.48	45.38	74.00	54.00	-8.62	AVG.
6308.33	V	46.48	---	3.74	50.22	---	74.00	54.00	-3.78	Peak
6681.66	V	44.89	---	4.23	49.12	---	74.00	54.00	-4.88	Peak
N/A										
3870.00	H	45.87	---	-3.77	42.10	---	74.00	54.00	-11.90	Peak
4955.00	H	48.96	---	-0.15	48.81	---	74.00	54.00	-5.19	Peak
6250.00	H	44.77	---	3.79	48.56	---	74.00	54.00	-5.44	Peak
6961.66	H	45.38	---	4.38	49.76	---	74.00	54.00	-4.24	Peak
N/A										

REMARKS:

1. Measuring frequencies from 1 GHz to the 10th harmonic of highest fundamental frequency.
2. Radiated emissions measured in frequency above 1000MHz were made with an instrument using peak/average detector mode.
3. Average test would be performed if the peak result were greater than the average limit or as required by the applicant.
4. Data of measurement within this frequency range shown " --- " in the table above means the reading of emissions are attenuated more than 20dB below the permissible limits or the field strength is too small to be measured.
5. Measurements above show only up to 6 maximum emissions noted, or would be lesser, with " N/A " remark, if no specific emissions from the EUT are recorded (ie: margin>20dB from the applicable limit) and considered that's already beyond the background noise floor.
6. Margin (dB) = Remark result (dBuV/m) – Average limit (dBuV/m).