



# FCC RF Test Report

**APPLICANT** : Motorola, Inc.  
**EQUIPMENT** : Enterprise Digital Assistant (EDA)  
**BRAND NAME** : Motorola  
**MODEL NAME** : MC659B  
**FCC ID** : UZ7MC659B  
**STANDARD** : FCC 47 CFR Part 2, 22(H), 24(E)  
**CLASSIFICATION** : PCS Licensed Transmitter Held to Ear (PCE)  
**Tx/Rx FREQUENCY RANGE** : GSM850 : 824.2 ~ 848.8 MHz /  
869.2 ~ 893.8 MHz  
GSM1900 : 1850.2 ~ 1909.8 MHz /  
1930.2 ~ 1989.8 MHz  
WCDMA Band V : 826.4 ~ 846.6 MHz /  
871.4 ~ 891.6 MHz  
WCDMA Band II : 1852.4 ~ 1907.6 MHz /  
1932.4 ~ 1987.6 MHz  
CDMA2000 BC0 : 824.70 ~ 848.31 MHz /  
869.70 ~ 893.31 MHz  
CDMA2000 BC1 : 1851.25 ~ 1908.75 MHz /  
1931.25 ~ 1988.75 MHz  
**MAX. ERP/EIRP POWER** : GSM850 (GSM) : 1.00 W  
GSM850 (EDGE 8) : 0.52 W  
GSM1900 (GSM) : 0.84 W  
GSM1900 (EDGE 8) : 0.69 W  
WCDMA Band V (RMC 12.2Kbps) : 0.14 W  
WCDMA Band II (RMC 12.2Kbps) : 0.26 W  
CDMA2000 BC0 (1xRTT) : 0.41 W  
CDMA2000 BC1 (1xRTT) : 0.82 W  
**EMISSION DESIGNATOR** : GMSK : 248KGXW  
8PSK : 244KG7W  
QPSK (WCDMA) : 4M18F9W  
QPSK (CDMA) : 1M28F9W



The product was received on Jan. 08, 2010 and completely tested on Jan. 23, 2010. We, SPORTON INTERNATIONAL INC., would like to declare that the tested sample has been evaluated in accordance with the procedures given in ANSI / TIA / EIA-603-C-2004 and shown compliance with the applicable technical standards.

The test results in this report apply exclusively to the tested model / sample. Without written approval of SPORTON INTERNATIONAL INC., the test report shall not be reproduced except in full.

Reviewed by:

---

Roy Wu / Manager



**SPORTON INTERNATIONAL INC.**

**No. 52, Hwa Ya 1<sup>st</sup> Rd., Hwa Ya Technology Park, Kwei-Shan Hsiang, Tao Yuan Hsien, Taiwan, R.O.C.**



# TABLE OF CONTENTS

**REVISION HISTORY..... 4**

**SUMMARY OF TEST RESULT ..... 5**

**1 GENERAL DESCRIPTION ..... 6**

    1.1 Applicant..... 6

    1.2 Manufacturer ..... 6

    1.3 Feature of Equipment Under Test..... 7

    1.4 Testing Site..... 9

    1.5 Applied Standards ..... 9

    1.6 Ancillary Equipment List..... 9

**2 TEST CONFIGURATION OF EQUIPMENT UNDER TEST ..... 10**

    2.1 Test Mode..... 10

    2.2 Connection Diagram of Test System ..... 13

**3 TEST RESULT..... 14**

    3.1 Conducted Output Power Measurement..... 14

    3.2 Effective Radiated Power and Effective Isotropic Radiated Power Measurement ..... 16

    3.3 Occupied Bandwidth Measurement ..... 22

    3.4 Band Edge Measurement..... 39

    3.5 Conducted Emission Measurement ..... 56

    3.6 Field Strength of Spurious Radiation Measurement ..... 77

    3.7 Frequency Stability Measurement..... 115

**4 LIST OF MEASURING EQUIPMENT ..... 120**

**5 UNCERTAINTY OF EVALUATION ..... 121**

**APPENDIX A. PHOTOGRAPHS OF EUT**

**APPENDIX B. SETUP PHOTOGRAPHS**





### SUMMARY OF TEST RESULT

Report Section	FCC Rule	IC Rule	Description	Limit	Result	Remark
3.1	§2.1046	N/A	Conducted Output Power	N/A	PASS	
3.2	§22.913(a)(2)	RSS-132(4.4) SRSP-503(5.1.3)	Effective Radiated Power	< 7 Watts	PASS	-
3.2	§24.232(c)	RSS-133 (6.4) SRSP-510(5.1.2)	Equivalent Isotropic Radiated Power	< 2 Watts	PASS	-
3.3	§2.1049 §22.917(a) §24.238(a)	N/A	Occupied Bandwidth	N/A	PASS	-
3.4	§2.1051 §22.917(a) §24.238(a)	RSS-132 (4.5.1) RSS-133 (6.5.1)	Band Edge Measurement	< 43+10log <sub>10</sub> (P[Watts])	PASS	-
3.5	§2.1051 §22.917(a) §24.238(a)	RSS-132 (4.5.1) RSS-133 (6.5.1)	Conducted Emission	< 43+10log <sub>10</sub> (P[Watts])	PASS	-
3.6	§2.1053 §22.917(a) §24.238(a)	RSS-132 (4.5.1) RSS-133 (6.5.1)	Field Strength of Spurious Radiation	< 43+10log <sub>10</sub> (P[Watts])	PASS	Under limit 6.11 dB at 3760 MHz
3.7	§2.1055 §22.355 §24.235	RSS-132(4.3) RSS-133(6.3)	Frequency Stability for Temperature & Voltage	< 2.5 ppm	PASS	-



# **1 General Description**

## **1.1 Applicant**

**Motorola, Inc.**

One Motorola Plaza, Holtsville, NY 11742-1300 USA

## **1.2 Manufacturer**

**Askey Technology (Jiangsu)**

No. 1388, Jiao Tong Road, WuJiang Economic-Technological Development Area, Jiangsu Province  
215200, P. R. C.



### 1.3 Feature of Equipment Under Test

Product Feature & Specification	
Equipment	Enterprise Digital Assistant (EDA)
Brand Name	Motorola
Model Name	MC659B
FCC ID	UZ7MC659B
Tx Frequency	GSM850 : 824 MHz ~ 849 MHz GSM1900 : 1850 MHz ~ 1910 MHz WCDMA Band V : 824 MHz ~ 849 MHz WCDMA Band II : 1850 MHz ~ 1910 MHz CDMA2000 BC0 : 824 MHz ~ 849 MHz CDMA2000 BC1 : 1850 MHz ~1910 MHz
Rx Frequency	GSM850 : 869 MHz ~ 894 MHz GSM1900 : 1930 MHz ~ 1990 MHz WCDMA Band V : 869 MHz ~ 894 MHz WCDMA Band II : 1930 MHz ~ 1990 MHz CDMA2000 BC0 : 869 MHz ~ 894 MHz CDMA2000 BC1 : 1930 MHz ~ 1990 MHz
Maximum Output Power to Antenna	GSM850 : 32.84 dBm GSM1900 : 29.45 dBm WCDMA Band V : 23.85 dBm WCDMA Band II : 23.47 dBm CDMA2000 BC0 : 24.61 dBm CDMA2000 BC1 : 24.59 dBm
Maximum ERP/EIRP	GSM850 (GSM) : 1.00 W (30.00 dBm) GSM850 (EDGE 8) : 0.52 W (27.18 dBm) GSM1900 (GSM) : 0.84 W (29.26 dBm) GSM1900 (EDGE 8) : 0.69 W (28.39 dBm) WCDMA Band V (RMC 12.2Kbps) : 0.14 W (21.33 dBm) WCDMA Band II (RMC 12.2Kbps) : 0.26 W (24.09 dBm) CDMA2000 BC0 (1xRTT) : 0.41 W (26.10 dBm) CDMA2000 BC1 (1xRTT) : 0.82 W (29.12 dBm)
Antenna Type	Fixed Internal Antenna
HW Version	EVT2
SW Version	BSP2410
Type of Modulation	GSM / GPRS : GMSK EDGE : 8PSK WCDMA : QPSK HSDPA : QPSK / 16QAM HSUPA : BPSK CDMA2000 : QPSK
Type of Emission	GMSK : 248KGXW 8PSK : 244KG7W QPSK (WCDMA) : 4M18F9W QPSK (CDMA2000) : 1M28F9W
EUT Stage	Identical Prototype



**Remark:**

1. For other wireless features of this EUT, the test report will be issued separately.
2. This test report recorded only product characteristics and test results of PCS Licensed Transmitter Held to Ear (PCE).
3. The above EUT's information was declared by manufacturer. Please refer to the specifications or user's manual for more detailed description.



## 1.4 Testing Site

<b>Test Site</b>	SPORTON INTERNATIONAL INC.		
<b>Test Site Location</b>	No. 52, Hwa Ya 1 <sup>st</sup> Rd., Hwa Ya Technology Park, Kwei-Shan Hsiang, Tao Yuan Hsien, Taiwan, R.O.C. TEL: +886-3-327-3456 FAX: +886-3-328-4978		
<b>Test Site No.</b>	<b>Sporton Site No.</b>		<b>FCC/IC Registration No.</b>
	TH02-HY	03CH07-HY	TW1022/4086B-1

## 1.5 Applied Standards

According to the specifications of the manufacturer, the EUT must comply with the requirements of the following standards:

- ♦ Preliminary Guidance for Receiving Applications for Certification of 3G Device. May 9, 2006.
- ♦ FCC 47 CFR Part 2, 22(H), 24(E)
- ♦ ANSI / TIA / EIA-603-C-2004
- ♦ IC RSS-132 Issue 2
- ♦ IC RSS-133 Issue 5

### Remark:

1. All test items were verified and recorded according to the standards and without any deviation during the test.
2. This EUT has also been tested and complied with the requirements of FCC Part 15, Subpart B (DoC), recorded in a separate test report.

## 1.6 Ancillary Equipment List

Item	Equipment	Trade Name	Model No.	FCC ID	Data Cable	Power Cord
1.	System Simulator	R&S	CMU200	N/A	N/A	Unshielded, 1.8 m
2.	Notebook	DELL	Vostro 1510	FCC DoC	N/A	AC I/P: Unshielded, 1.2 m DC O/P: Shielded, 1.8 m



## **2 Test Configuration of Equipment Under Test**

### **2.1 Test Mode**

During all testing, EUT is in link mode with base station emulator at maximum power level. The spurious emission measurements were carried out in semi-anechoic chamber with 3-meter test range, and EUT is rotated on three test planes to find out the worst emission.

Frequency range investigated for radiated emission is as follows:

1. 30 MHz to 9000 MHz for GSM850 and WCDMA Band V and CDMA2000 BC0.
2. 30 MHz to 19000 MHz for GSM1900 and WCDMA Band II and CDMA2000 BC1.



Test Modes		
Band	Radiated TCs	Conducted TCs
GSM 850	<ul style="list-style-type: none"> <li>■ GSM Link + Qwerty Keypad</li> <li>■ EDGE 8 Link + Qwerty Keypad</li> <li>■ GSM Link + 802.11a Tx CH165 + Qwerty Keypad</li> </ul>	<ul style="list-style-type: none"> <li>■ GSM Link</li> <li>■ EDGE 8 Link</li> </ul>
GSM 1900	<ul style="list-style-type: none"> <li>■ GSM Link + Qwerty Keypad</li> <li>■ EDGE 8 Link + Qwerty Keypad</li> <li>■ GSM Link + 802.11a Tx CH165 + Qwerty Keypad</li> </ul>	<ul style="list-style-type: none"> <li>■ GSM Link</li> <li>■ EDGE 8 Link</li> </ul>
WCDMA Band V	<ul style="list-style-type: none"> <li>■ RMC 12.2Kbps Link + Qwerty Keypad</li> <li>■ RMC 12.2Kbps Link + 802.11a Tx CH165 + Qwerty Keypad</li> </ul>	<ul style="list-style-type: none"> <li>■ RMC 12.2Kbps Link</li> </ul>
WCDMA Band II	<ul style="list-style-type: none"> <li>■ RMC 12.2Kbps Link + Qwerty Keypad</li> <li>■ RMC 12.2Kbps Link + 802.11a Tx CH165 + Qwerty Keypad</li> </ul>	<ul style="list-style-type: none"> <li>■ RMC 12.2Kbps Link</li> </ul>
CDMA2000 BC0	<ul style="list-style-type: none"> <li>■ 1xRTT Link + Qwerty Keypad</li> <li>■ 1xRTT Link + Numeric Keypad</li> <li>■ 1xRTT Link + 802.11a Tx CH165 + Qwerty Keypad</li> <li>■ 1xRTT Link + 802.11a Tx CH165 + Numeric Keypad</li> </ul>	<ul style="list-style-type: none"> <li>■ 1xRTT Link Mode</li> </ul>
CDMA2000 BC1	<ul style="list-style-type: none"> <li>■ 1xRTT Link + Qwerty Keypad</li> <li>■ 1xRTT Link + Numeric Keypad</li> <li>■ 1xRTT Link + 802.11a Tx CH165 + Qwerty Keypad</li> <li>■ 1xRTT Link + 802.11a Tx CH165 + Numeric Keypad</li> </ul>	<ul style="list-style-type: none"> <li>■ 1xRTT Link Mode</li> </ul>

**Note:**

1. The maximum power levels are GSM mode for GMSK link, EDGE multi-slot class 8 mode for 8PSK link, RMC 12.2Kbps mode for WCDMA band V and WCDMA band II, 1xRTT FCH\_RC3+SO55 mode for CDMA2000 BC0 and CDMA2000 BC1 Link, only these modes were used for all tests.
2. The radiated emission testing were performed together with USB charging cable with AC power.



The conducted power tables are as follows:

Conducted Power (*Unit: dBm)						
Band	GSM850			GSM1900		
Channel	128	189	251	512	661	810
Frequency	824.2	836.4	848.8	1850.2	1880.0	1909.8
GSM	<b>32.84</b>	32.67	32.49	29.38	29.35	<b>29.45</b>
GPRS 8	32.82	32.66	32.47	29.38	29.36	29.45
GPRS 10	29.30	29.14	28.97	29.08	29.39	29.44
GPRS 12	31.74	31.58	31.38	28.26	28.24	28.32
DTM 5 (GPRS)	29.42	29.44	29.41	28.48	28.43	28.41
DTM 9 (GPRS)	29.36	29.33	29.20	28.38	28.47	28.56
DTM 11 (GPRS)	29.34	29.31	29.19	28.34	28.45	28.54
EGPRS 8	<b>26.95</b>	26.70	26.65	25.39	25.43	<b>25.60</b>
EGPRS 10	26.94	26.76	26.54	25.48	25.41	25.48
EGPRS 12	26.81	26.71	26.51	25.41	25.36	25.44
DTM 5 (EGPRS)	26.83	26.71	26.54	25.26	25.23	25.37
DTM 9 (EGPRS)	26.84	26.69	26.54	25.24	25.24	25.37
DTM 11 (EGPRS)	26.83	26.69	26.52	25.24	25.22	25.35

Conducted Power (*Unit: dBm)						
Band	WCDMA Band V			WCDMA Band II		
Channel	4132	4182	4233	9262	9400	9538
Frequency	826.4	836.4	846.6	1852.4	1880.0	1907.6
RMC 12.2K	23.61	<b>23.85</b>	23.76	23.41	23.43	<b>23.47</b>
HSDPA Subtest-1	23.60	23.84	23.70	23.45	23.29	23.46
HSDPA Subtest-2	23.47	23.65	23.48	23.34	23.29	23.36
HSDPA Subtest-3	23.02	23.26	23.49	23.00	22.89	23.01
HSDPA Subtest-4	22.81	23.16	23.04	22.80	22.84	22.93
HSUPA Subtest-1	22.44	23.17	22.42	22.50	23.11	23.23
HSUPA Subtest-2	21.72	22.00	21.30	21.56	21.37	21.29
HSUPA Subtest-3	21.90	22.05	22.06	22.04	21.82	22.27
HSUPA Subtest-4	21.71	22.07	22.33	21.71	21.72	21.67
HSUPA Subtest-5	22.51	23.63	23.00	22.48	23.18	23.16

Conducted Power (*Unit: dBm)						
Band	CDMA2000 BC0			CDMA2000 BC1		
Channel	1013	384	777	25	600	1175
Frequency	824.7	836.52	848.31	1851.25	1880	1908.75
1xRTT FCH_RC1+SO55	24.24	24.47	24.04	24.41	24.42	24.32
1xRTT FCH_RC3+SO55	24.24	<b>24.61</b>	24.06	<b>24.59</b>	24.38	24.21
1xRTT FCH+SCH_RC3+SO32	24.23	24.45	23.96	24.34	24.31	24.19
1xEV-DO RTAP 9.6K	24.04	24.38	23.88	24.37	24.26	24.05
1xEV-DO RTAP 38.4K	24.18	24.35	23.89	24.33	24.25	24.28
1xEV-DO RTAP 153.6K	24.14	24.30	23.89	24.23	24.22	24.21
1xEV-DO RETAP 128K	24.10	24.45	23.92	24.36	24.12	24.02
1xEV-DO RETAP 2048K	24.23	24.46	24.10	24.52	24.29	24.35
1xEV-DO RETAP 4096K	24.21	24.58	24.11	24.52	24.45	24.34
1xEV-DO RETAP 12288K	24.22	24.60	24.09	24.58	24.44	24.20

## 2.2 Connection Diagram of Test System

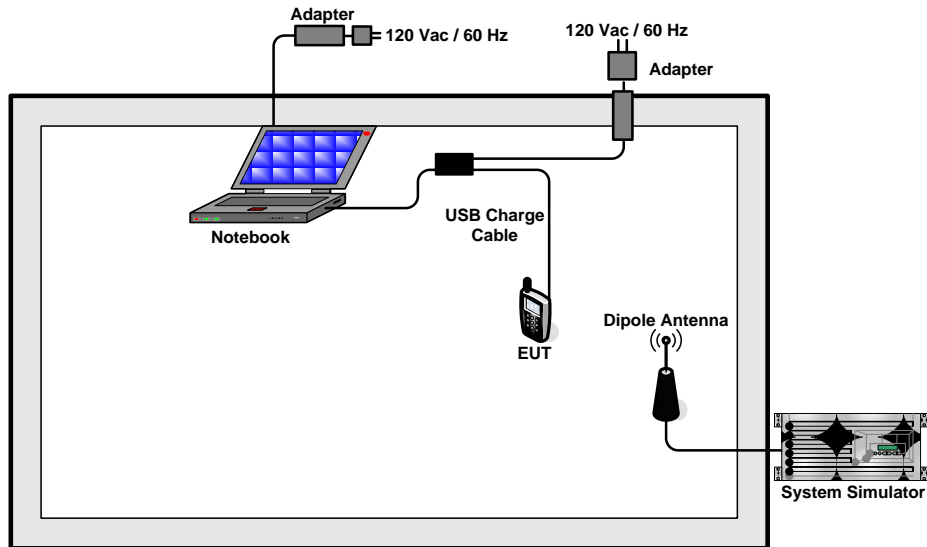

### 3 Test Result

#### 3.1 Conducted Output Power Measurement

##### 3.1.1 Description of the Conducted Output Power Measurement

A base station simulator was used to establish communication with the EUT. Its parameters were set to transmit the maximum power on the EUT. The measured power in the radio frequency on the transmitter output terminals shall be reported.

##### 3.1.2 Measuring Instruments

See list of measuring instruments of this test report.

##### 3.1.3 Test Procedures

1. The transmitter output port was connected to base station.
2. Set EUT at maximum power through base station.
3. Select lowest, middle, and highest channels for each band and different modulation.

##### 3.1.4 Test Setup

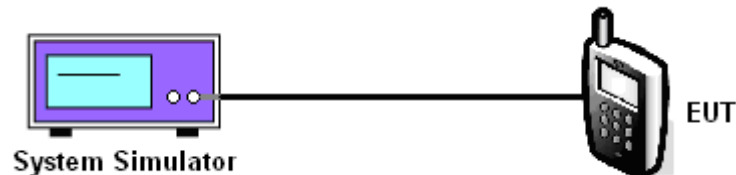

3.1.5 Test Result of Conducted Output Power

Cellular Band				
Modes	Channel	Frequency (MHz)	Conducted Power (dBm)	Conducted Power (Watts)
GSM850 (GSM)	128 (Low)	824.2	32.84	1.92
	189 (Mid)	836.4	32.67	1.85
	251 (High)	848.8	32.49	1.77
GSM850 (EDGE 8)	128 (Low)	824.2	26.95	0.50
	189 (Mid)	836.4	26.70	0.47
	251 (High)	848.8	26.65	0.46
WCDMA Band V (RMC 12.2Kbps)	4132 (Low)	826.4	23.61	0.23
	4182 (Mid)	836.4	23.85	0.24
	4233 (High)	846.6	23.76	0.24
CDMA2000 BC0 (1xRTT FCH_RC3+SO55)	1013 (Low)	824.70	24.24	0.27
	384 (Mid)	836.52	24.61	0.29
	777 (High)	848.31	24.09	0.25

PCS Band				
Modes	Channel	Frequency (MHz)	Conducted Power (dBm)	Conducted Power (Watts)
GSM1900 (GSM)	512 (Low)	1850.2	29.08	0.81
	661 (Mid)	1880.0	29.39	0.87
	810 (High)	1909.8	29.45	0.88
GSM1900 (EDGE 8)	512 (Low)	1850.2	25.39	0.35
	661 (Mid)	1880.0	25.43	0.35
	810 (High)	1909.8	25.60	0.36
WCDMA Band II (RMC 12.2Kbps)	9262 (Low)	1852.4	23.41	0.22
	9400 (Mid)	1880.0	23.43	0.22
	9538 (High)	1907.6	23.47	0.22
CDMA2000 BC1 (1xRTT FCH_RC3+SO55)	25 (Low)	1851.25	24.59	0.29
	600 (Mid)	1880.00	24.38	0.27
	1175 (High)	1908.75	24.21	0.26



## **3.2 Effective Radiated Power and Effective Isotropic Radiated Power Measurement**

### **3.2.1 Description of the ERP/EIRP Measurement**

ERP/EIRP is measured by substitution method according to ANSI / TIA / EIA-603-C-2004. The ERP of mobile transmitters must not exceed 7 Watts and the EIRP of mobile transmitters are limited to 2 Watts.

### **3.2.2 Measuring Instruments**

See list of measuring instruments of this test report.

### **3.2.3 Test Procedures**

1. The EUT was placed on an non-conductive rotating platform with 0.8 meter height in a semi-anechoic chamber. The radiated emission at the fundamental frequency was measured at 3 m with a test antenna and a spectrum analyzer with RBW= 3MHz,VBW= 3MHz, and peak detector settings.
2. During the measurement, the EUT was enforced in maximum power and linked with a base station. The highest emission was recorded from analyzer power level (LVL) from the 360 degrees rotation of the turntable and the test antenna raised and lowered over a range from 1 to 4 meters in both horizontally and vertically polarized orientations.
3. Effective Isotropic Radiated Power (EIRP) was measured by substitution method according to TIA/EIA-603-C. The EUT was replaced by dipole antenna (substitution antenna) at same location, and then a known power from S.G. was applied into the dipole antenna through a Tx cable, and then recorded the maximum Analyzer reading through raised and lowered the test antenna. The correction factor (in dB) = S.G. - Tx Cable loss + Substitution antenna gain - Analyzer reading. Then the EUT's EIRP was calculated with the correction factor,  $EIRP = LVL + \text{Correction factor}$  and  $ERP = EIRP - 2.15$ .



### 3.2.4 Test Setup

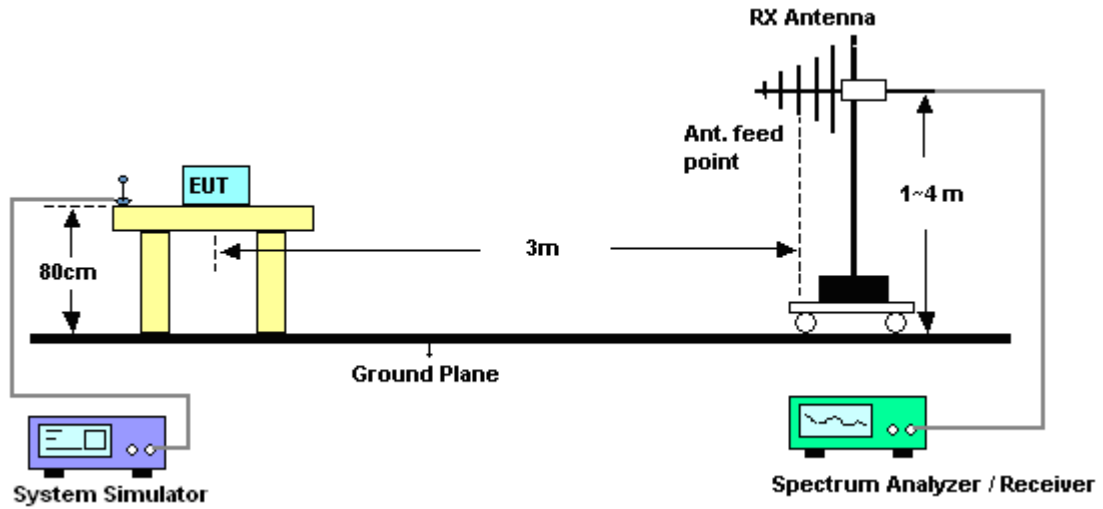

3.2.5 Test Result of ERP

GSM850 (GSM) Radiated Power ERP for EUT with Qwerty Keypad				
Horizontal Polarization				
Frequency (MHz)	LVL (dBm)	Correction Factor (dB)	ERP (dBm)	ERP (W)
824.2	-0.78	32.04	29.11	0.81
836.4	-0.76	32.91	30.00	1.00
848.8	-0.90	32.84	29.79	0.95
Vertical Polarization				
Frequency (MHz)	LVL (dBm)	Correction Factor (dB)	ERP (dBm)	ERP (W)
824.2	-8.73	36.10	25.22	0.33
836.4	-8.90	34.41	23.36	0.22
848.8	-8.91	34.65	23.59	0.23

\* ERP = LVL (dBm) + Correction Factor (dB) – 2.15

GSM850 (EDGE 8) Radiated Power ERP for EUT with Qwerty Keypad				
Horizontal Polarization				
Frequency (MHz)	LVL (dBm)	Correction Factor (dB)	ERP (dBm)	ERP (W)
824.2	-3.14	32.04	26.75	0.47
836.4	-3.58	32.91	27.18	0.52
848.8	-3.82	32.84	26.87	0.49
Vertical Polarization				
Frequency (MHz)	LVL (dBm)	Correction Factor (dB)	ERP (dBm)	ERP (W)
824.2	-11.87	36.10	22.08	0.16
836.4	-12.20	34.41	20.06	0.10
848.8	-11.98	34.65	20.52	0.11

\* ERP = LVL (dBm) + Correction Factor (dB) – 2.15



WCDMA Band V (RMC 12.2Kbps) Radiated Power ERP for EUT with Qwerty Keypad				
Horizontal Polarization				
Frequency (MHz)	LVL (dBm)	Correction Factor (dB)	ERP (dBm)	ERP (W)
826.40	-8.95	32.04	20.94	0.12
836.40	-9.43	32.91	21.33	0.14
846.60	-9.82	32.84	20.87	0.12
Vertical Polarization				
Frequency (MHz)	LVL (dBm)	Correction Factor (dB)	ERP (dBm)	ERP (W)
826.40	-17.31	36.10	16.64	0.05
836.40	-17.58	34.41	14.68	0.03
846.60	-17.54	34.65	14.96	0.03

\* ERP = LVL (dBm) + Correction Factor (dB) – 2.15

CDMA2000 BC0 1xRTT FCH_RC3+SO55 Radiated Power ERP for EUT with Qwerty Keypad				
Horizontal Polarization				
Frequency (MHz)	LVL (dBm)	Correction Factor (dB)	ERP (dBm)	ERP (W)
824.70	-3.88	32.04	26.01	0.40
836.52	-4.66	32.91	26.10	0.41
848.31	-5.36	32.84	25.33	0.34
Vertical Polarization				
Frequency (MHz)	LVL (dBm)	Correction Factor (dB)	ERP (dBm)	ERP (W)
824.70	-12.62	36.10	21.33	0.14
836.52	-12.88	34.41	19.38	0.09
848.31	-12.52	34.65	19.98	0.10

\* ERP = LVL (dBm) + Correction Factor (dB) – 2.15

3.2.6 Test Result of EIRP

GSM1900 (GSM) Radiated Power EIRP for EUT with Qwerty Keypad				
Horizontal Polarization				
Frequency (MHz)	LVL (dBm)	Correction Factor (dB)	EIRP (dBm)	EIRP (W)
1850.2	-12.08	41.24	29.16	0.82
1880.0	-12.62	41.46	28.84	0.77
1909.8	-11.95	41.21	29.26	0.84
Vertical Polarization				
Frequency (MHz)	LVL (dBm)	Correction Factor (dB)	EIRP (dBm)	EIRP (W)
1850.2	-19.19	41.52	22.33	0.17
1880.0	-19.83	43.10	23.27	0.21
1909.8	-20.88	42.73	21.85	0.15

\* EIRP = LVL (dBm) + Correction Factor (dB)

GSM1900 (EDGE 8) Radiated Power EIRP for EUT with Qwerty Keypad				
Horizontal Polarization				
Frequency (MHz)	LVL (dBm)	Correction Factor (dB)	EIRP (dBm)	EIRP (W)
1850.2	-13.08	41.24	28.16	0.65
1880.0	-13.20	41.46	28.26	0.67
1909.8	-12.82	41.21	28.39	0.69
Vertical Polarization				
Frequency (MHz)	LVL (dBm)	Correction Factor (dB)	EIRP (dBm)	EIRP (W)
1850.2	-21.10	41.52	20.42	0.11
1880.0	-20.72	43.10	22.38	0.17
1909.8	-21.88	42.73	20.85	0.12

\* EIRP = LVL (dBm) + Correction Factor (dB)



WCDMA Band II (RMC 12.2Kbps) Radiated Power EIRP for EUT with Qwerty Keypad				
Horizontal Polarization				
Frequency (MHz)	LVL (dBm)	Correction Factor (dB)	EIRP (dBm)	EIRP (W)
1852.40	-18.24	41.24	23.00	0.20
1880.00	-18.01	41.46	23.45	0.22
1907.60	-17.12	41.21	24.09	0.26
Vertical Polarization				
Frequency (MHz)	LVL (dBm)	Correction Factor (dB)	EIRP (dBm)	EIRP (W)
1852.40	-26.71	41.52	14.81	0.03
1880.00	-25.46	43.10	17.64	0.06
1907.60	-25.94	42.73	16.79	0.05

\* EIRP = LVL (dBm) + Correction Factor (dB)

CDMA2000 BC1 1xRTT FCH_RC3+SO55 _ Radiated Power EIRP for EUT with Qwerty Keypad				
Horizontal Polarization				
Frequency (MHz)	LVL (dBm)	Correction Factor (dB)	EIRP (dBm)	EIRP (W)
1851.25	-12.64	41.24	28.60	0.72
1880.00	-13.15	41.46	28.31	0.68
1908.75	-12.09	41.21	29.12	0.82
Vertical Polarization				
Frequency (MHz)	LVL (dBm)	Correction Factor (dB)	EIRP (dBm)	EIRP (W)
1851.25	-21.48	41.52	20.04	0.10
1880.00	-20.62	43.10	22.48	0.18
1908.75	-20.09	42.73	22.64	0.18

\* EIRP = LVL (dBm) + Correction Factor (dB)

### 3.3 Occupied Bandwidth Measurement

#### 3.3.1 Description of Occupied Bandwidth Measurement

The emission bandwidth is defined as the width of the signal between two points, located at the 2 sides of the carrier frequency, outside of which all emissions are attenuated at least 26 dB below the transmitter power.

#### 3.3.2 Measuring Instruments

See list of measuring instruments of this test report.

#### 3.3.3 Test Procedures

1. The EUT was connected to Spectrum Analyzer and Base Station via power divider.
2. The 99% and 26 dB occupied bandwidth (BW) of the middle channel for the highest RF powers were measured.

#### 3.3.4 Test Setup

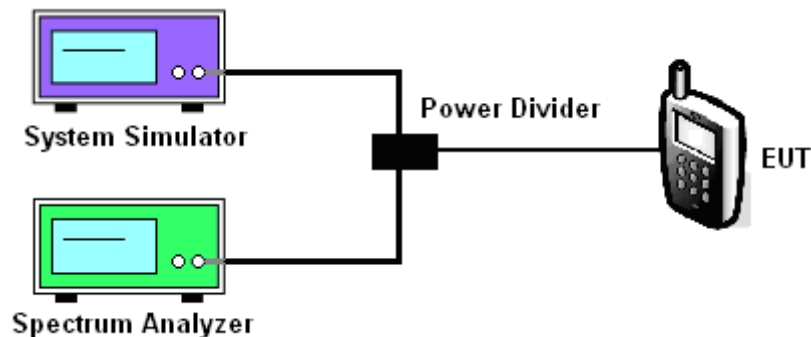



3.3.5 Test Result (Plots) of Occupied Bandwidth

Band :	GSM 850	Power Stage :	High
Test Mode :	GSM Link		

99% Occupied Bandwidth Plot on Channel 189

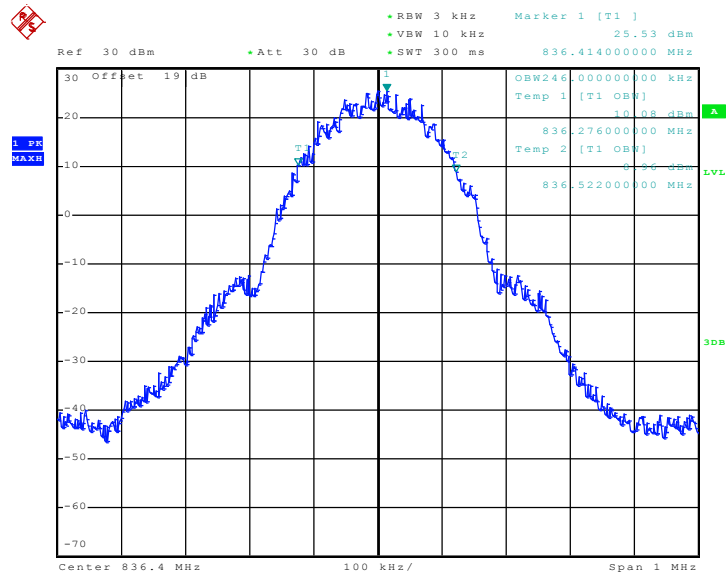

Date: 20..JAN.2010 23:00:55

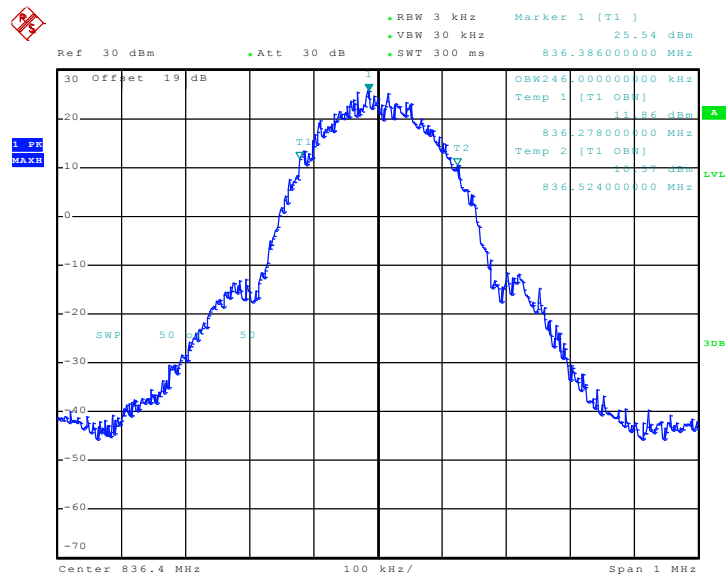

Date: 20..JAN.2010 23:06:10



26dB Bandwidth Plot on Channel 189

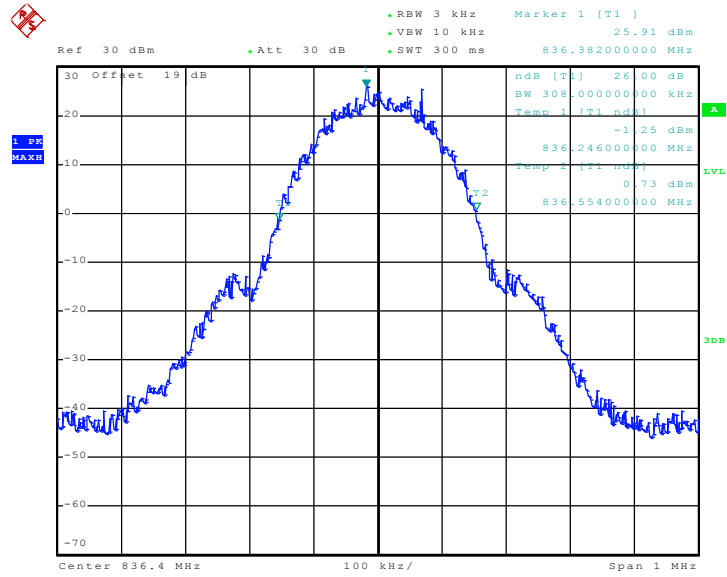

Date: 20..JAN.2010 22:58:47





<b>Band :</b>	GSM 850	<b>Power Stage :</b>	High
<b>Test Mode :</b>	EDGE 8 Link		

99% Occupied Bandwidth Plot on Channel 189

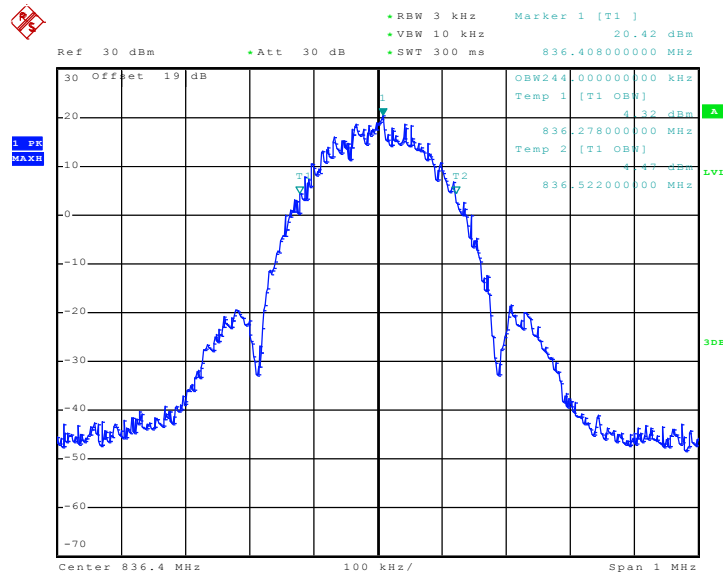

Date: 20..JAN..2010 23:03:22

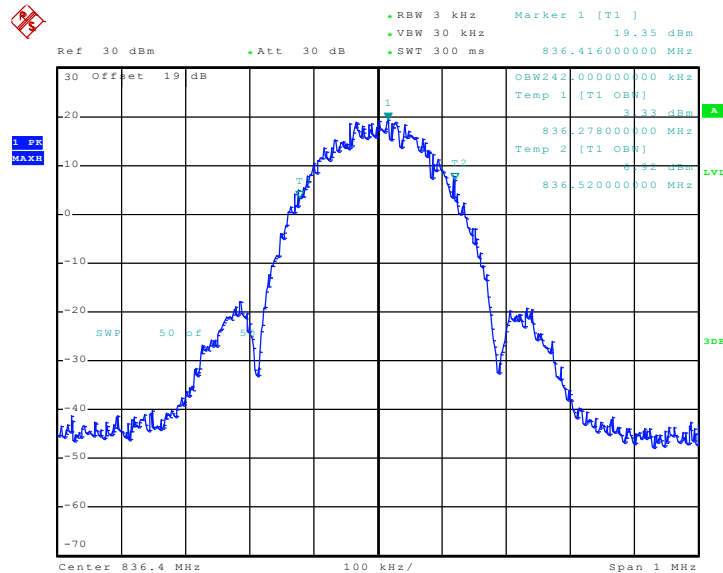

Date: 20..JAN..2010 23:05:28



26dB Bandwidth Plot on Channel 189

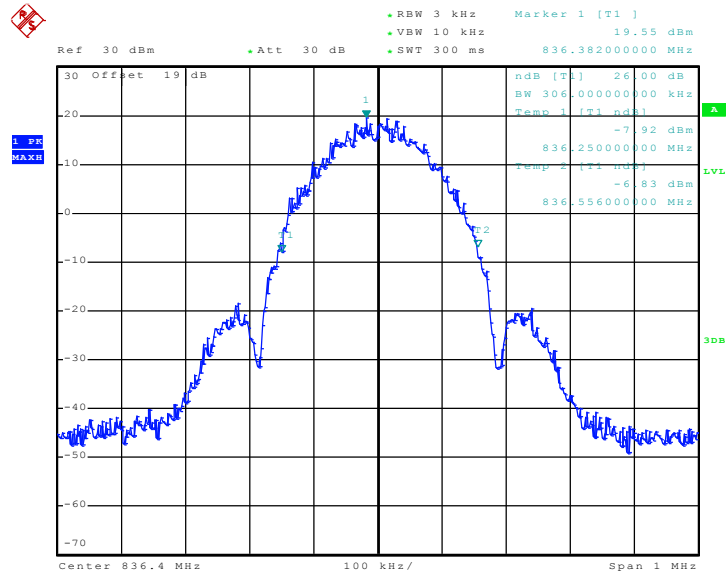

Date: 20..JAN.2010 22:55:54



<b>Band :</b>	GSM 1900	<b>Power Stage :</b>	High
<b>Test Mode :</b>	GSM Link		

99% Occupied Bandwidth Plot on Channel 661

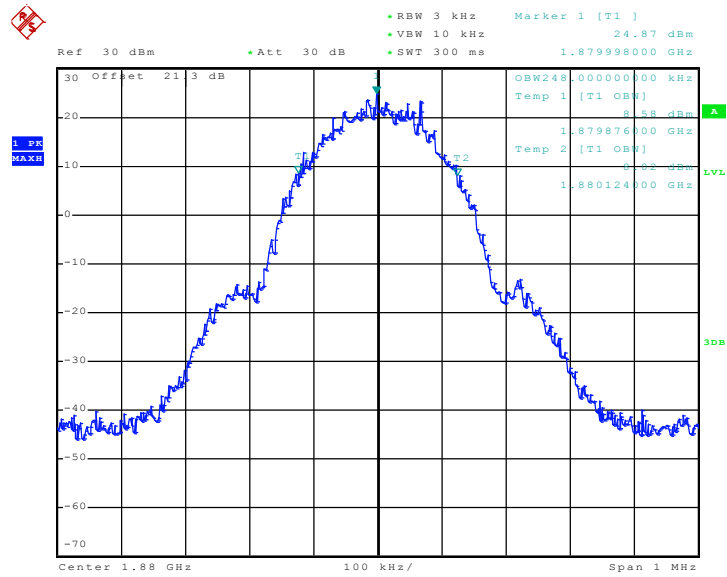

Date: 20..JAN..2010 22:10:45

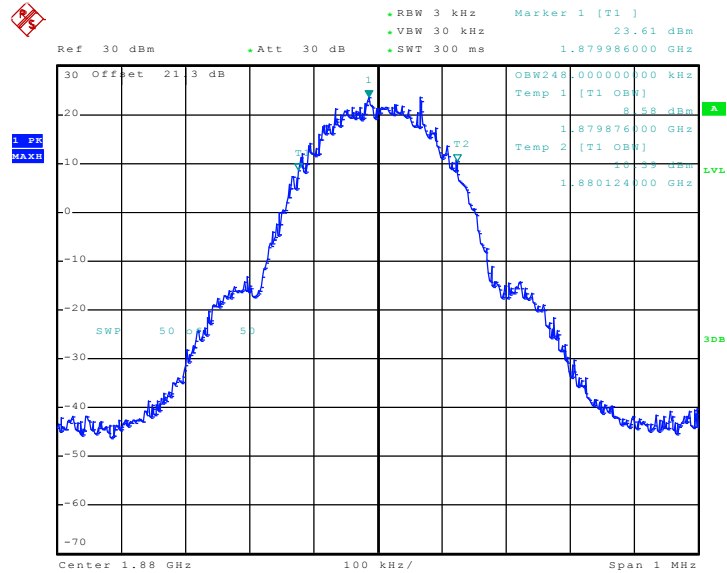

Date: 20..JAN..2010 22:13:32





<b>Band :</b>	GSM 1900	<b>Power Stage :</b>	High
<b>Test Mode :</b>	EDGE 8 Link		

99% Occupied Bandwidth Plot on Channel 661

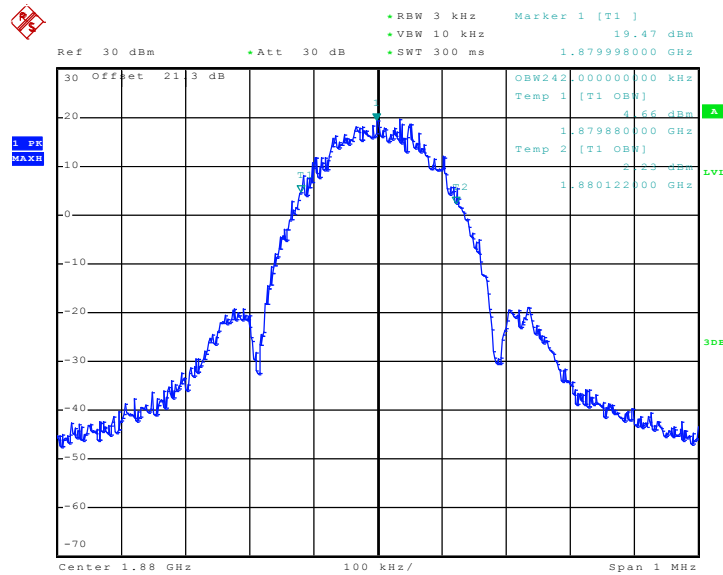

Date: 20..JAN..2010 22:03:00

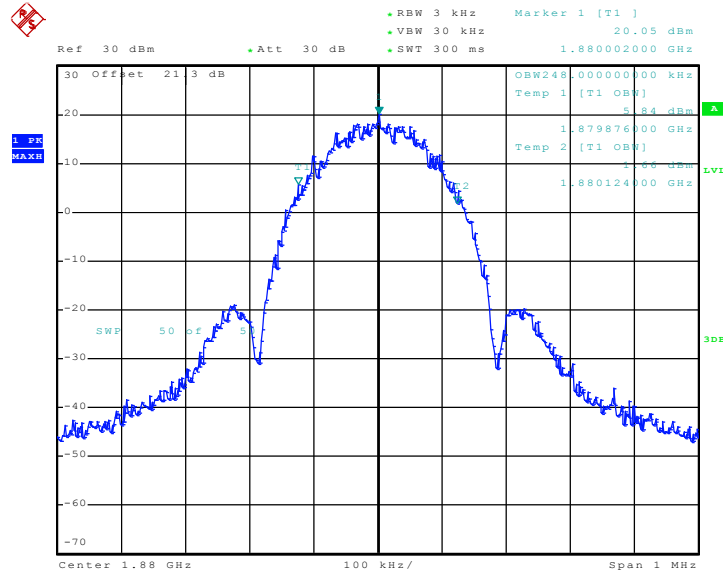

Date: 20..JAN..2010 22:03:53



26dB Bandwidth Plot on Channel 661

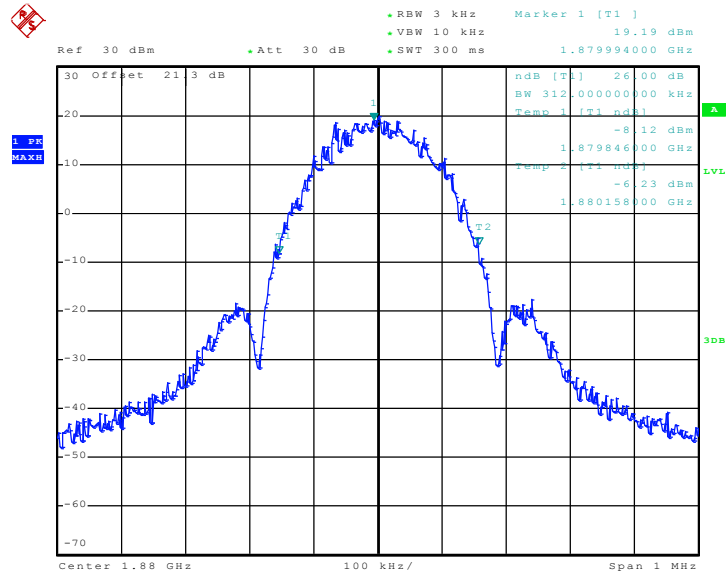

Date: 20..JAN.2010 22:05:47



Band :	WCDMA Band V	Power Stage :	High
Test Mode :	RMC 12.2Kbps Link		

99% Occupied Bandwidth Plot on Channel 4182

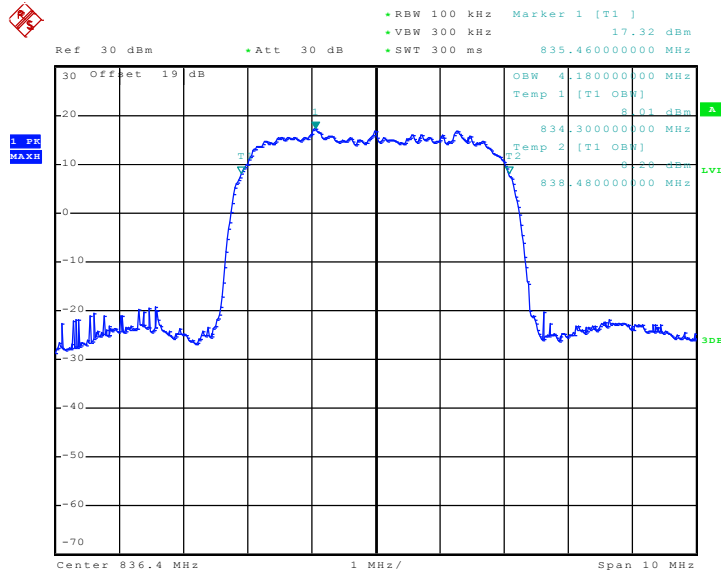

Date: 21..JAN..2010 00:18:25

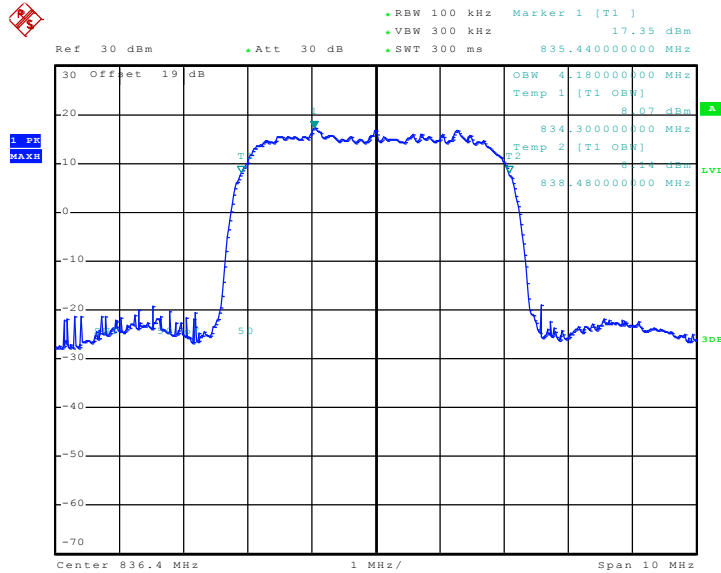

Date: 21..JAN..2010 00:25:26



26dB Bandwidth Plot on Channel 4182

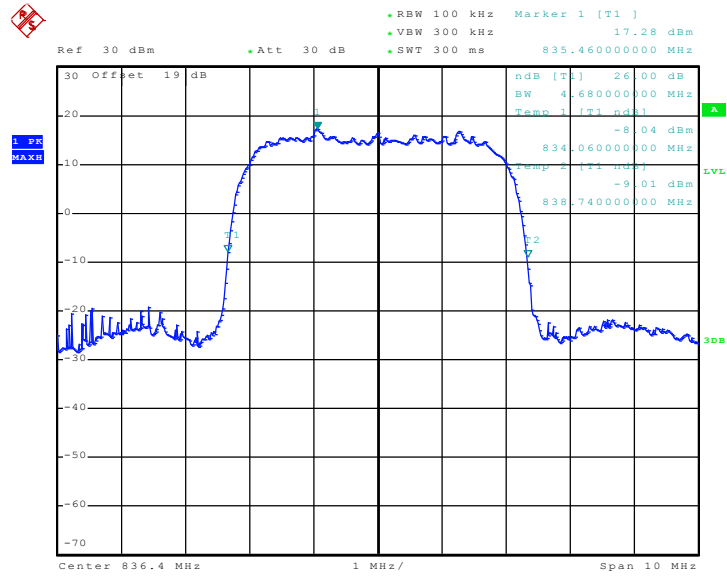

Date: 21.JAN.2010 00:23:31





<b>Band :</b>	WCDMA Band II	<b>Power Stage :</b>	High
<b>Test Mode :</b>	RMC 12.2Kbps Link		

99% Occupied Bandwidth Plot on Channel 9400

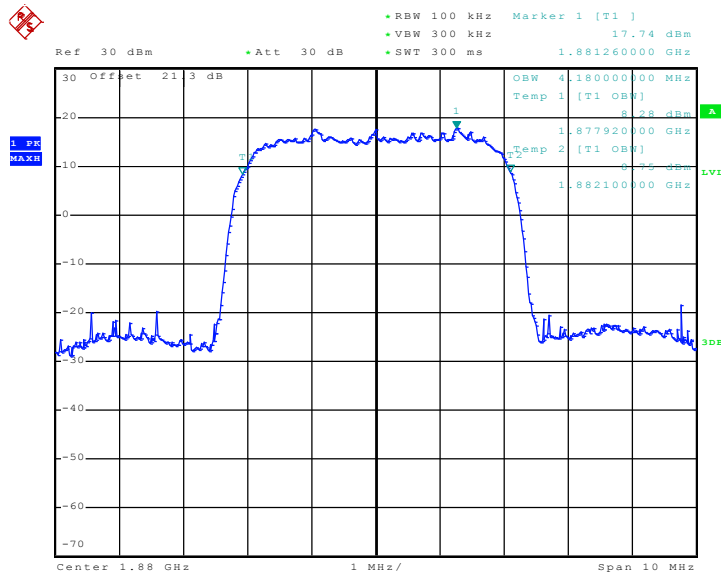

Date: 21..JAN..2010 00:42:53

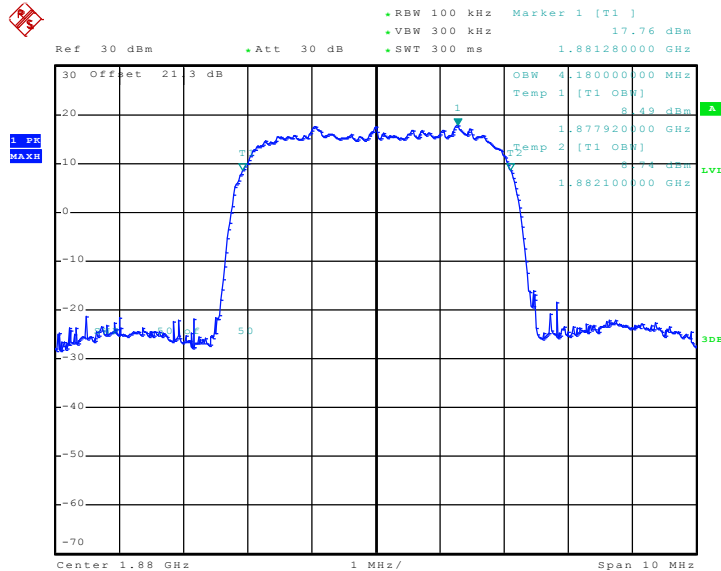

Date: 21..JAN..2010 00:43:30





<b>Band :</b>	CDMA2000 BC0	<b>Power Stage :</b>	High
<b>Test Mode :</b>	1xRTT FCH_RC3+SO55 Link		

99% Occupied Bandwidth Plot on Channel 384

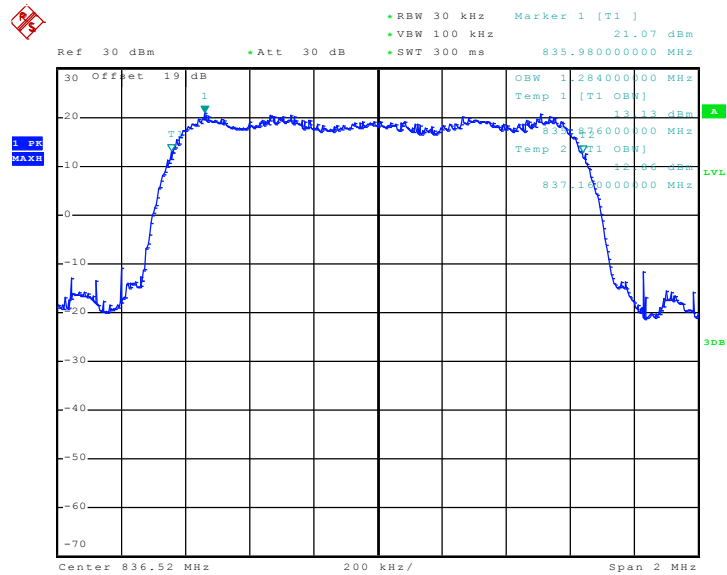

Date: 21..JAN..2010 01:41:47

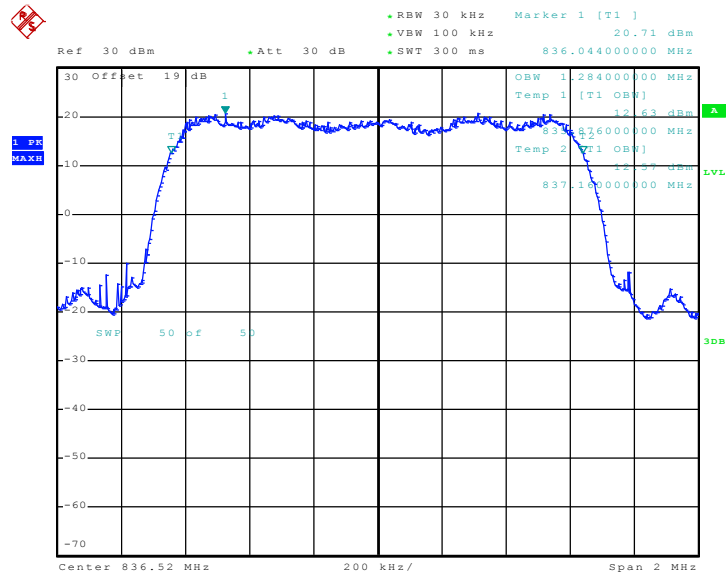

Date: 21..JAN..2010 01:42:31



26dB Bandwidth Plot on Channel 384

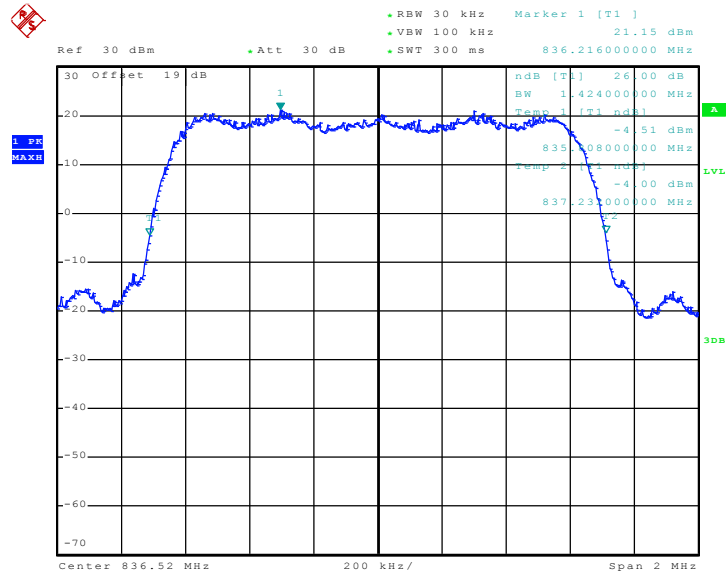

Date: 21.JAN.2010 01:43:19



<b>Band :</b>	CDMA2000 BC1	<b>Power Stage :</b>	High
<b>Test Mode :</b>	1xRTT FCH_RC3+SO55 Link		

99% Occupied Bandwidth Plot on Channel 600

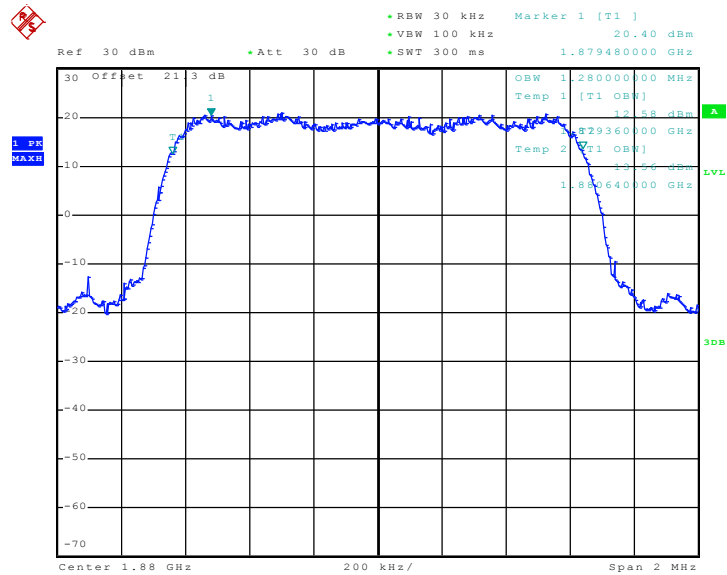

Date: 21..JAN..2010 01:20:05

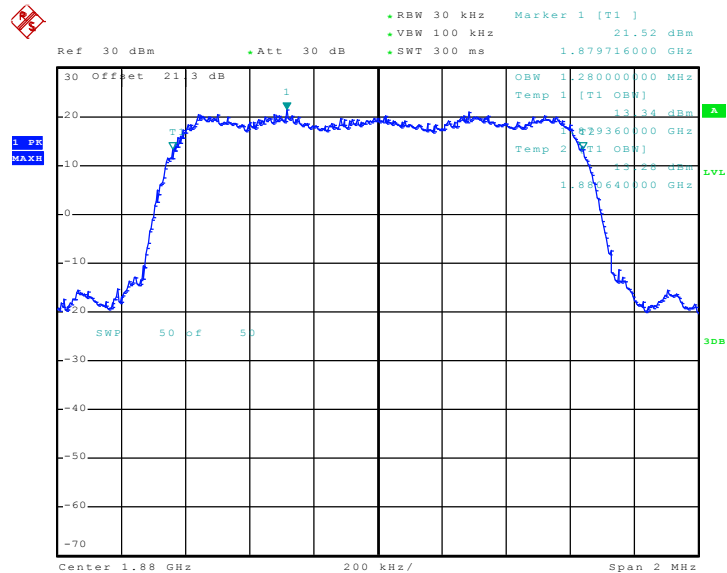

Date: 21..JAN..2010 01:22:01



26dB Bandwidth Plot on Channel 600

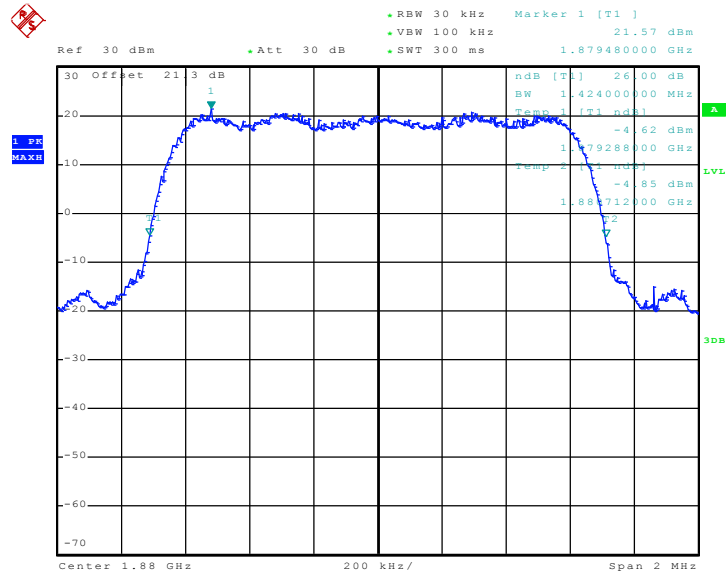

Date: 21.JAN.2010 01:15:54

## 3.4 Band Edge Measurement

### 3.4.1 Description of Band Edge Measurement

The power of any emission outside of the authorized operating frequency ranges must be lower than the transmitter power (P) by a factor of at least  $43 + 10 \log (P)$  dB.

### 3.4.2 Measuring Instruments

See list of measuring instruments of this test report.

### 3.4.3 Test Procedures

1. The EUT was connected to Spectrum Analyzer and Base Station via power divider.
2. The band edges of low and high channels for the highest RF powers were measured. Setting RBW as roughly  $BW/100$ .
3. The RBW was replaced by 10 kHz, due to the spectrum analyzer IF-Filter including an excess of the limit. A worst case correction factor of  $10 \log (1\% BW/\text{measurement RBW})$  was implemented.

### 3.4.4 Test Setup

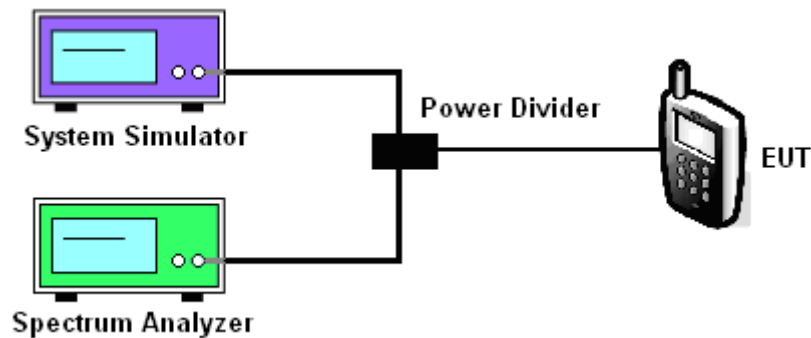



### 3.4.5 Test Result (Plots) of Conducted Band Edge

Band :	GSM850	Power Stage :	High
Test Mode :	GSM Link		

Lower Band Edge Plot on Channel 128

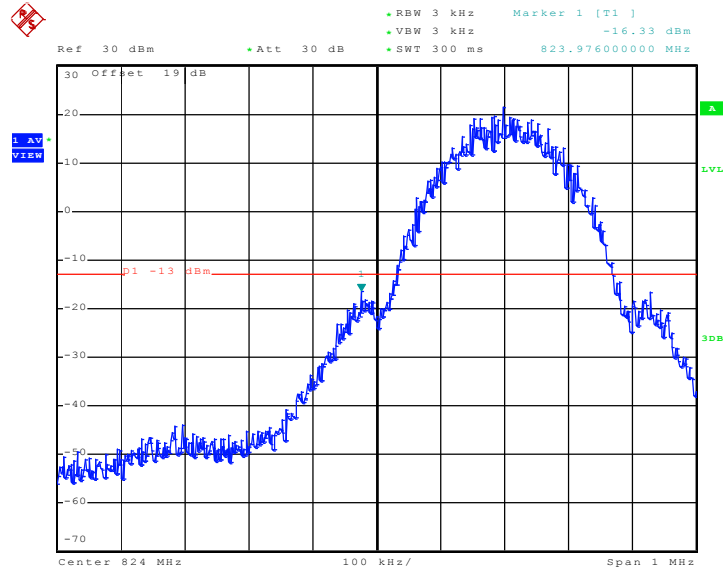

Date: 20.JAN.2010 22:35:32

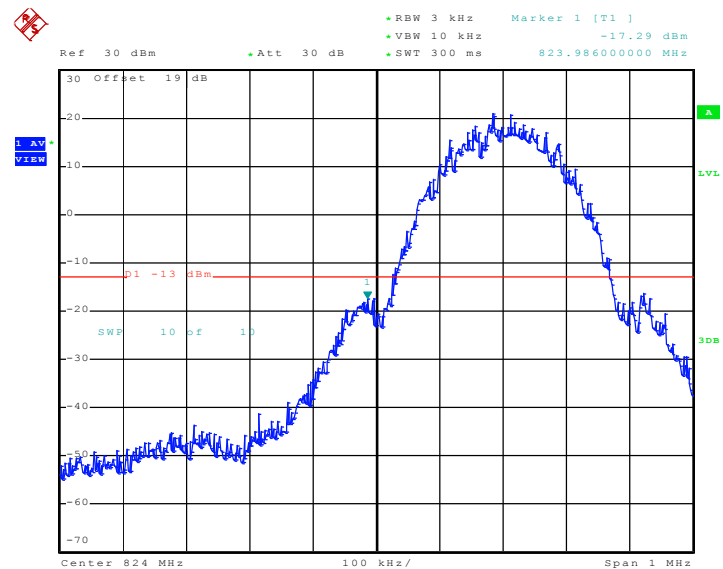

Date: 20.JAN.2010 22:43:21





Higher Band Edge Plot on Channel 251

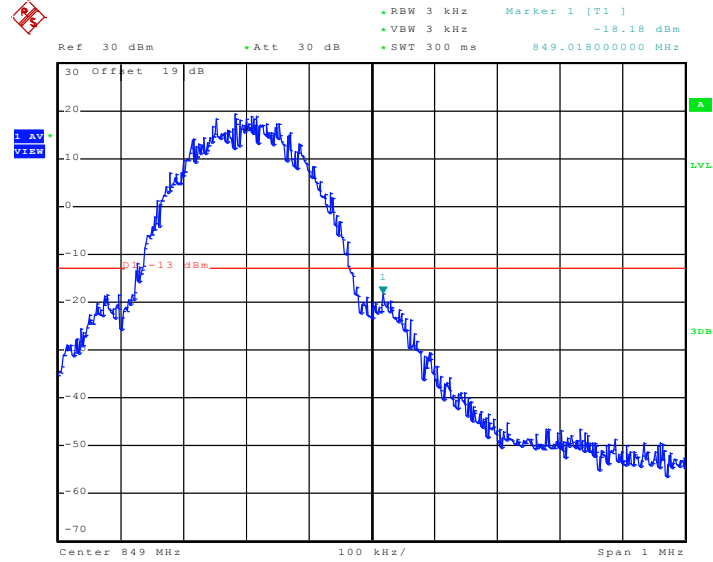

Date: 20.JAN.2010 22:36:21

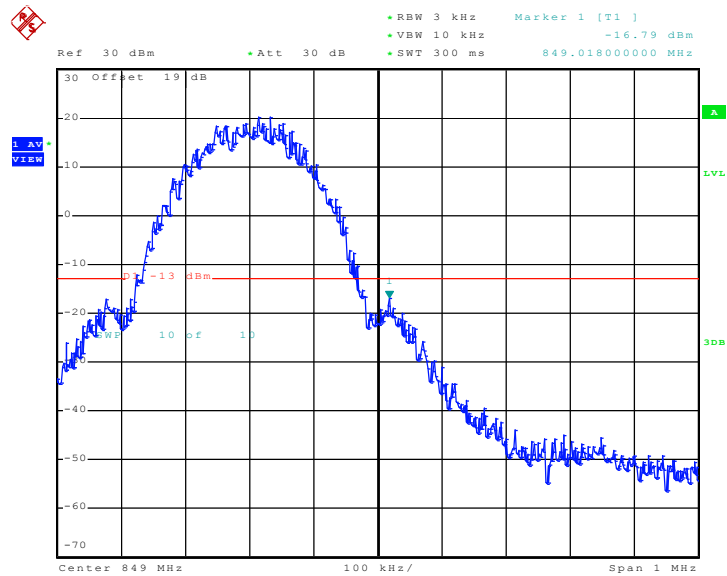

Date: 20.JAN.2010 22:42:15



Band :	GSM850	Power Stage :	High
Test Mode :	EDGE 8 Link		

Lower Band Edge Plot on Channel 128

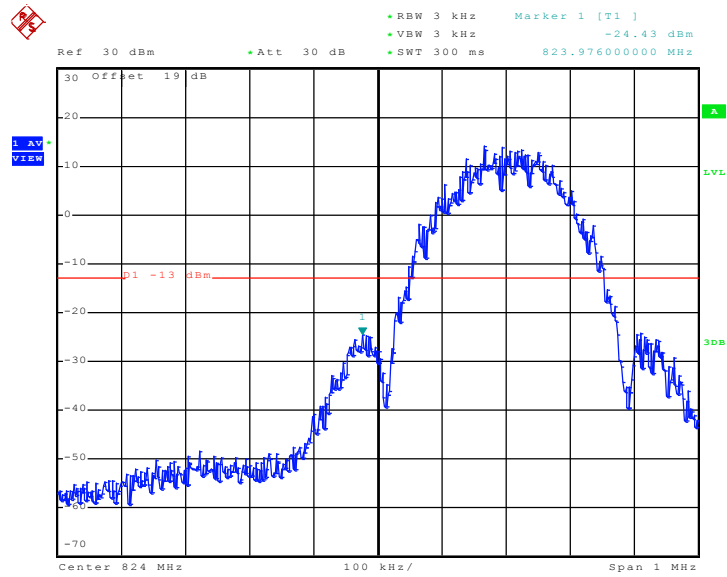

Date: 20..JAN..2010 22:38:49

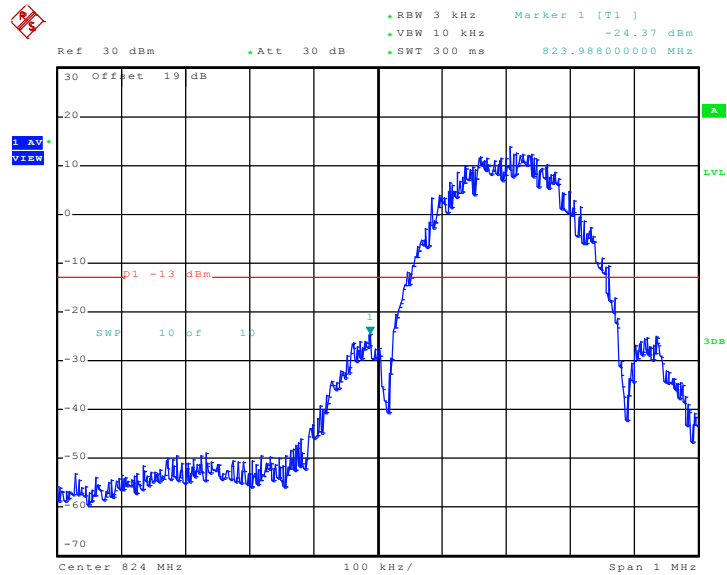

Date: 20..JAN..2010 22:39:39



Higher Band Edge Plot on Channel 251

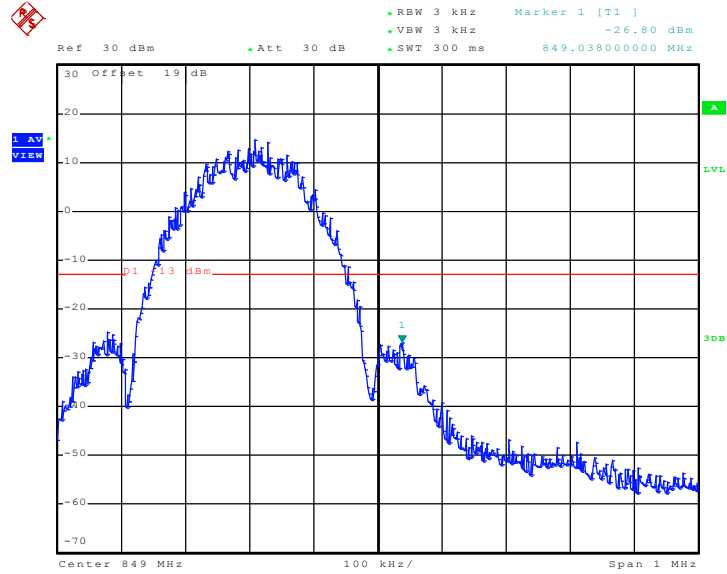

Date: 20.JAN.2010 22:37:58

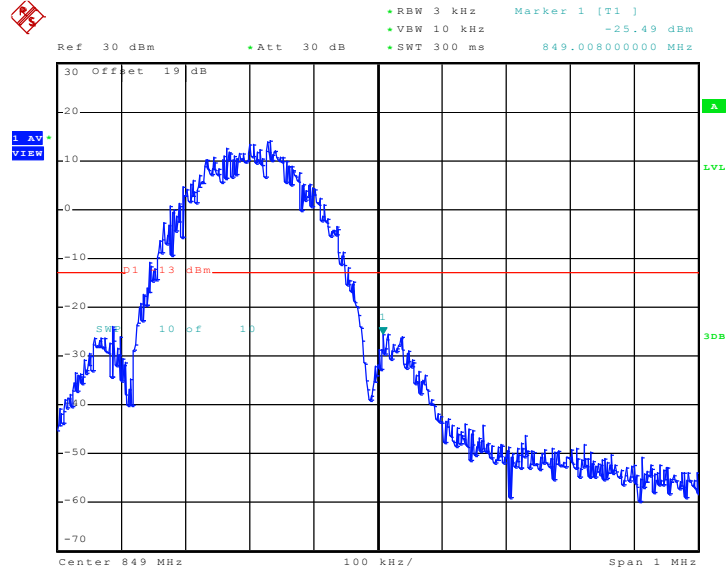

Date: 20.JAN.2010 22:40:56



Band :	GSM1900	Power Stage :	High
Test Mode :	GSM Link		

Lower Band Edge Plot on Channel 512

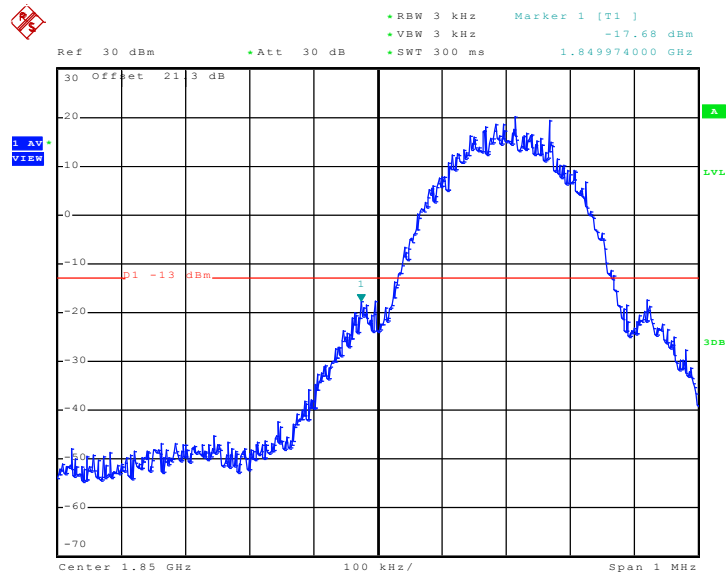

Date: 20..JAN..2010 22:23:52

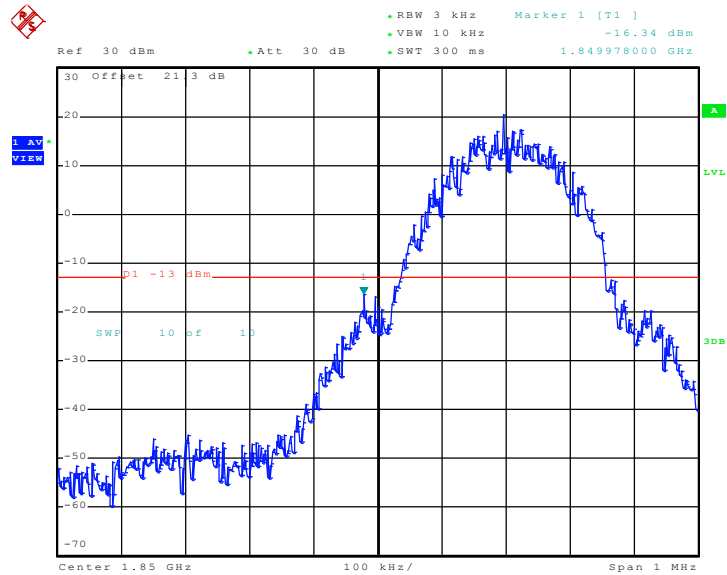

Date: 20..JAN..2010 21:54:40



Higher Band Edge Plot on Channel 810

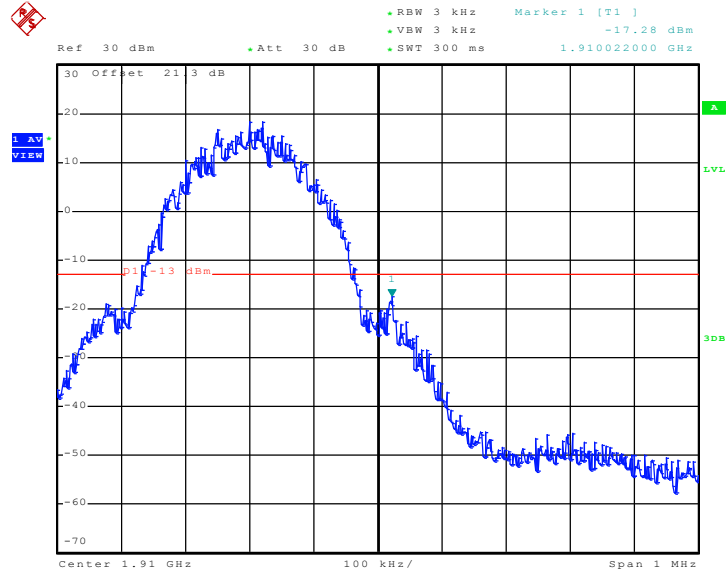

Date: 20.JAN.2010 22:22:53

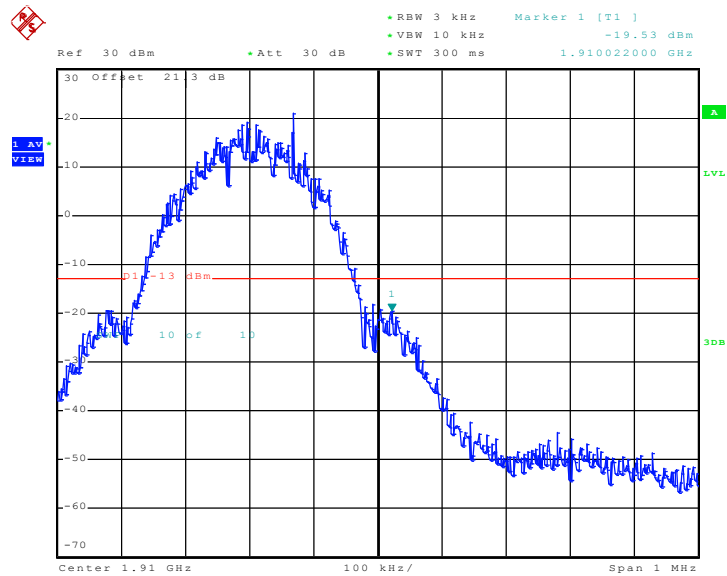

Date: 20.JAN.2010 21:55:24



Band :	GSM1900	Power Stage :	High
Test Mode :	EDGE 8 Link		

Lower Band Edge Plot on Channel 512

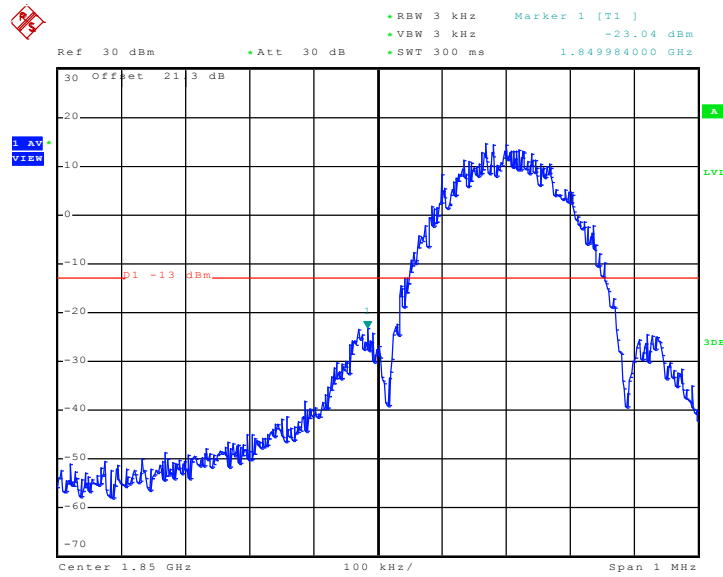

Date: 20..JAN..2010 22:27:02

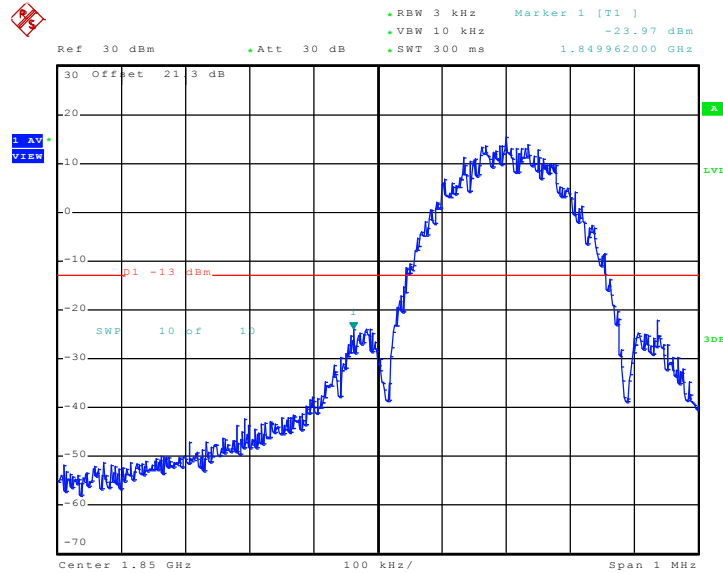

Date: 20..JAN..2010 21:57:12



Higher Band Edge Plot on Channel 810

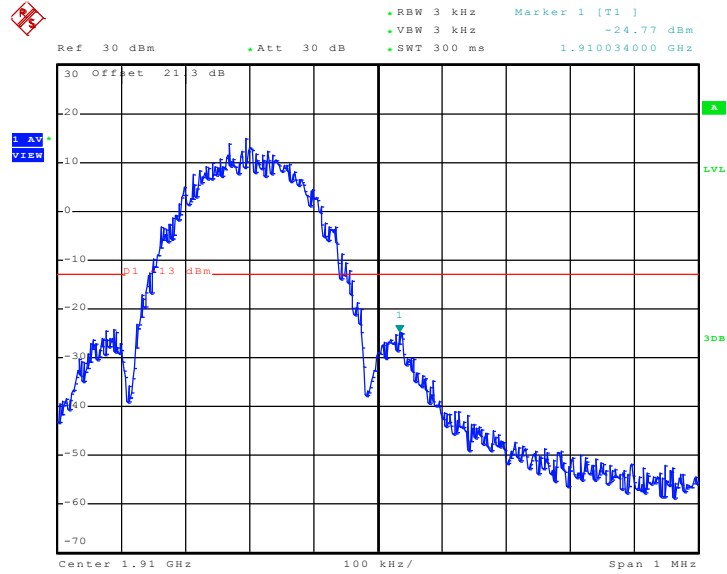

Date: 20.JAN.2010 22:30:29

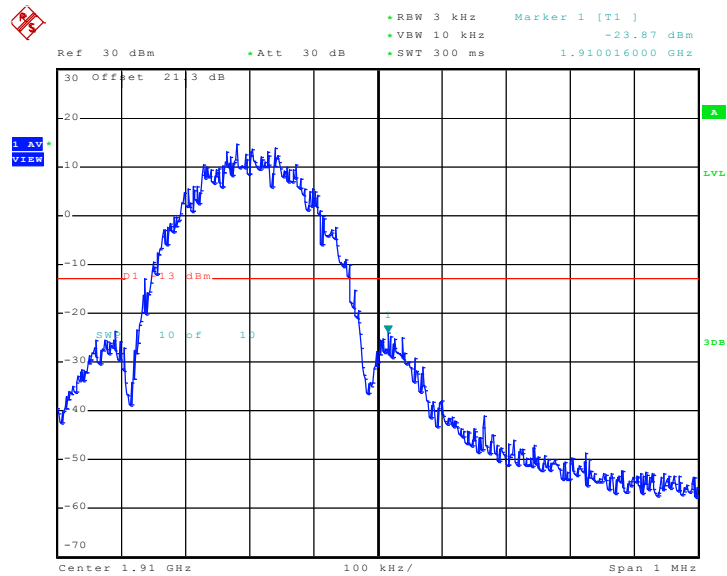

Date: 20.JAN.2010 21:56:10



Band :	WCDMA Band V	Power Stage :	High
Test Mode :	RMC 12.2Kbps Link		

Lower Band Edge Plot on Channel 4132

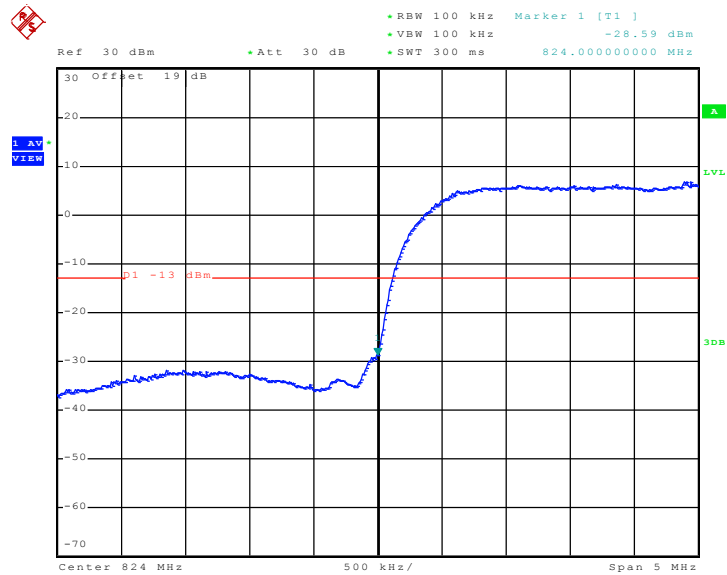

Date: 21..JAN..2010 00:33:49

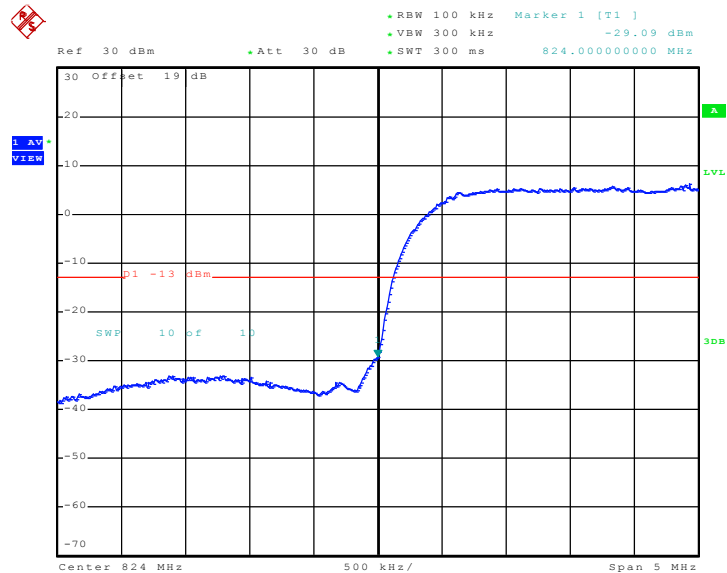

Date: 21..JAN..2010 00:36:24





Higher Band Edge Plot on Channel 4233

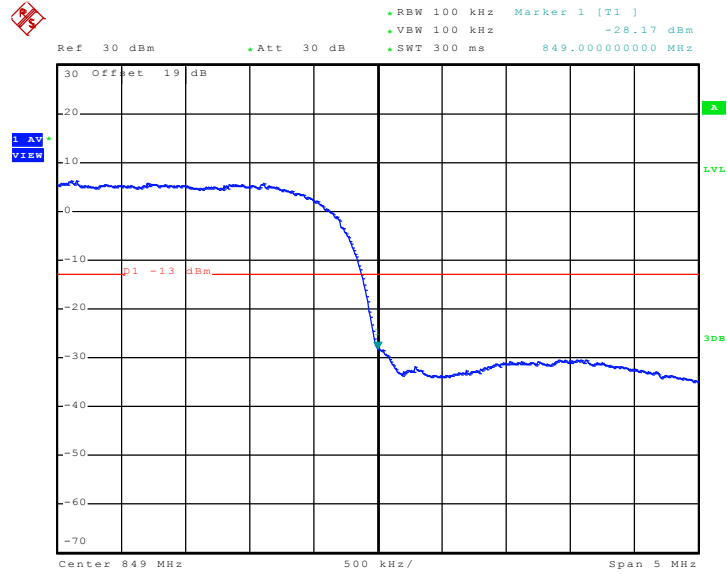

Date: 21.JAN.2010 00:34:59

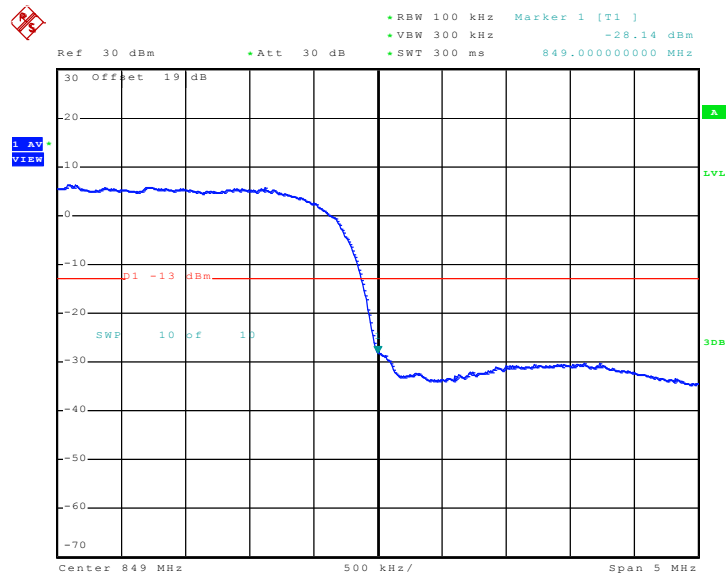

Date: 21.JAN.2010 00:35:55



Band :	WCDMA Band II	Power Stage :	High
Test Mode :	RMC 12.2Kbps Link		

Lower Band Edge Plot on Channel 9262

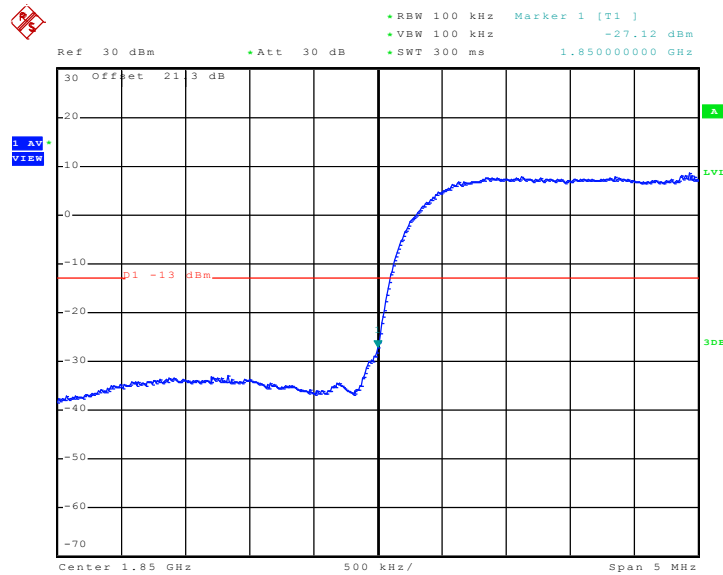

Date: 21..JAN..2010 00:40:52

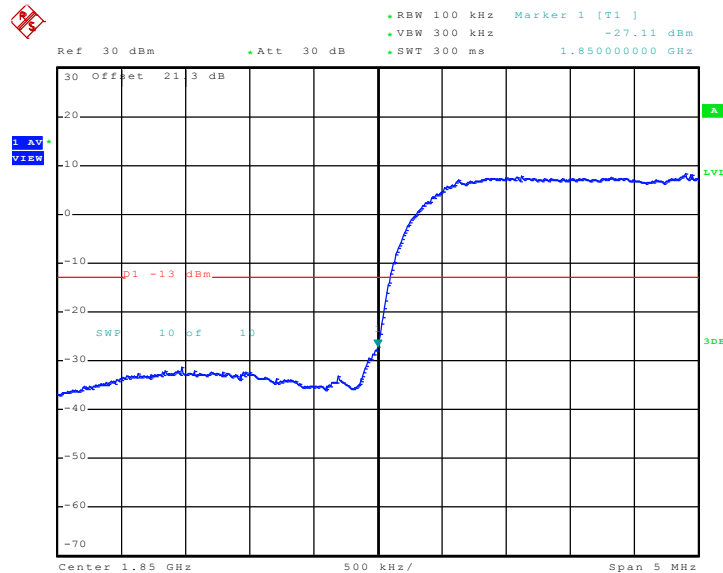

Date: 21..JAN..2010 00:39:14



Higher Band Edge Plot on Channel 9538

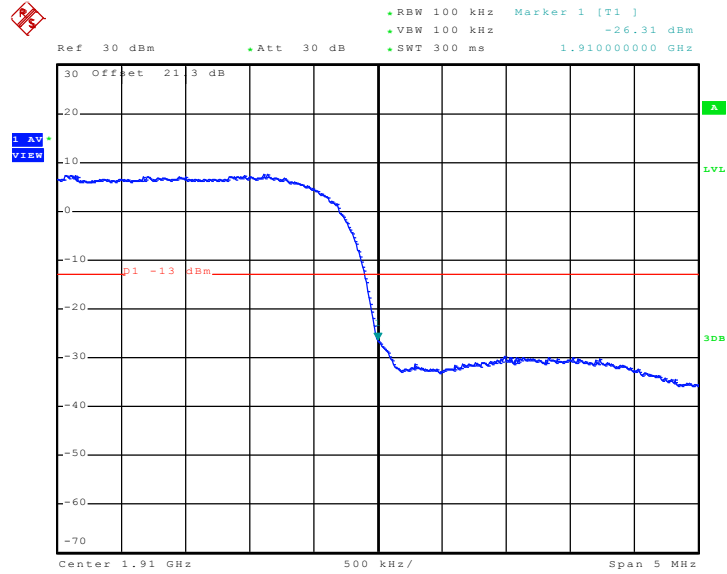

Date: 21.JAN.2010 00:40:27

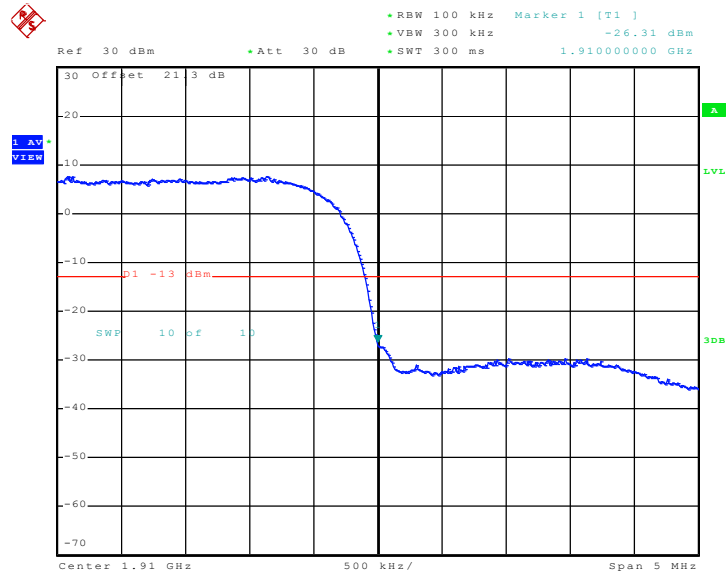

Date: 21.JAN.2010 00:39:57



Band :	CDMA2000 BC0	Power Stage :	High
Test Mode :	1xRTT FCH_RC3+SO55		

Lower Band Edge Plot on Channel 1013

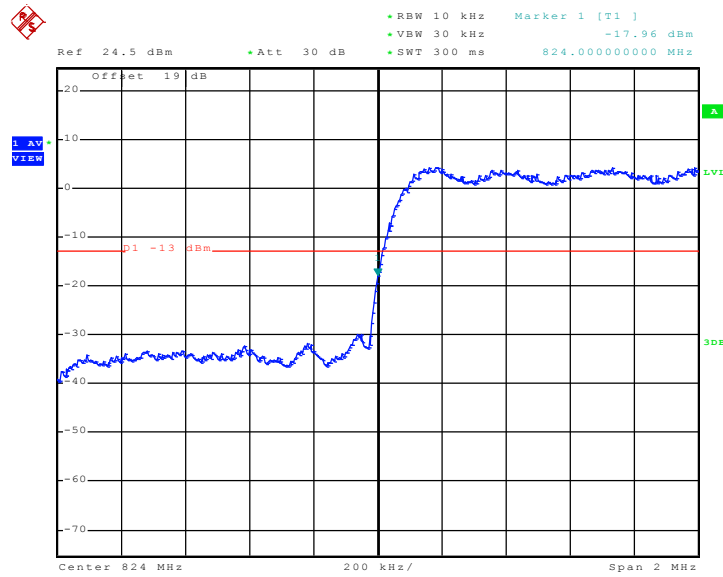

Date: 21..JAN..2010 01:35:33

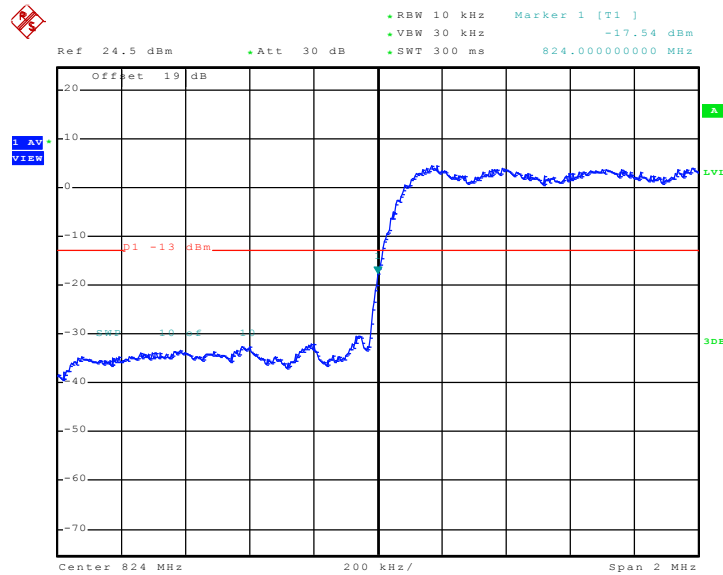

Date: 21..JAN..2010 01:33:56



Higher Band Edge Plot on Channel 777

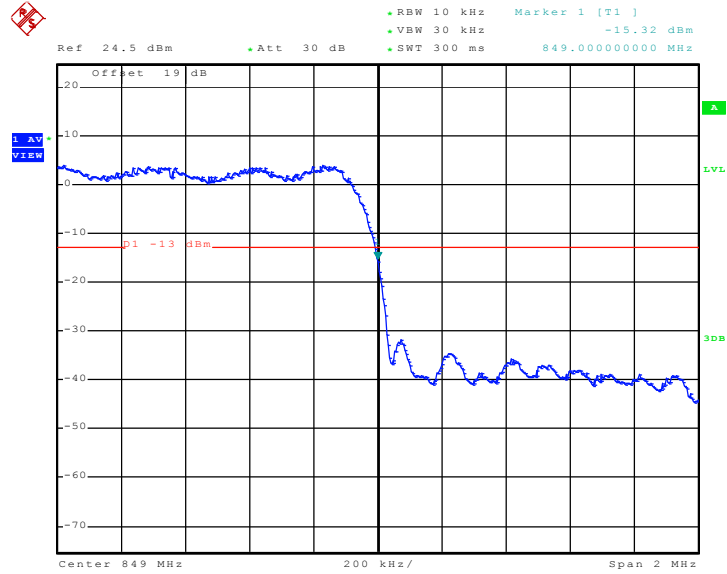

Date: 21.JAN.2010 01:35:03

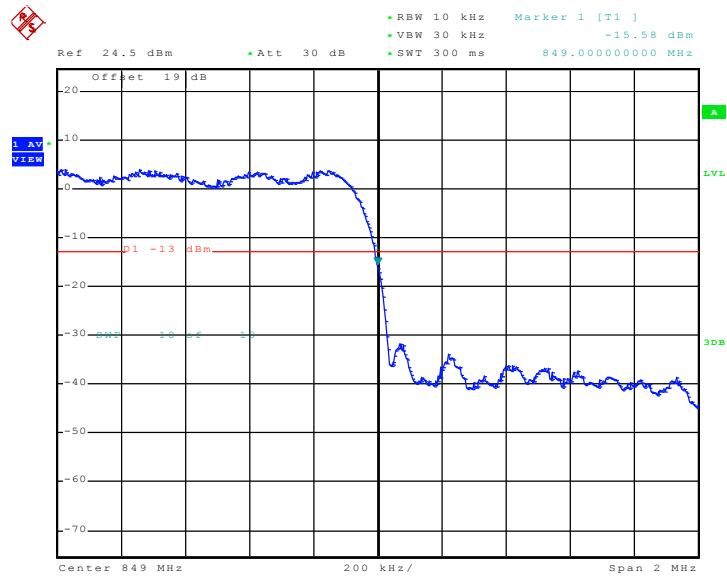

Date: 21.JAN.2010 01:34:28



Band :	CDMA2000 BC1	Power Stage :	High
Test Mode :	1xRTT FCH_RC3+SO55		

Lower Band Edge Plot on Channel 25

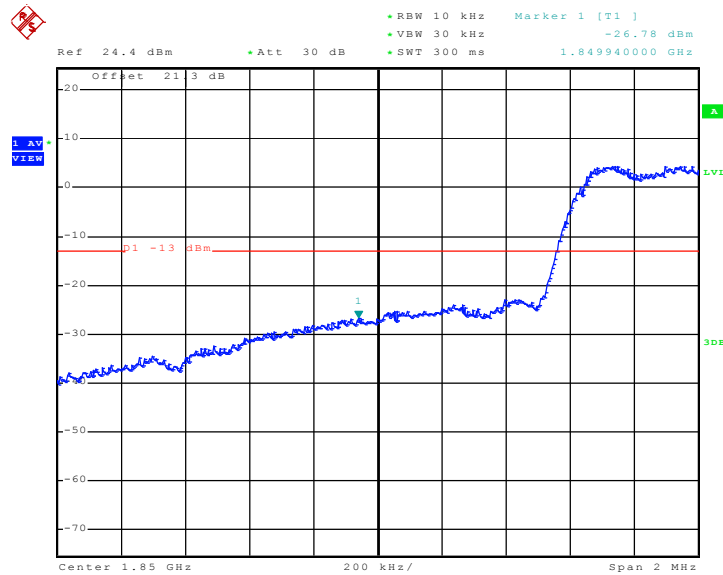

Date: 22..JAN..2010 06:52:18

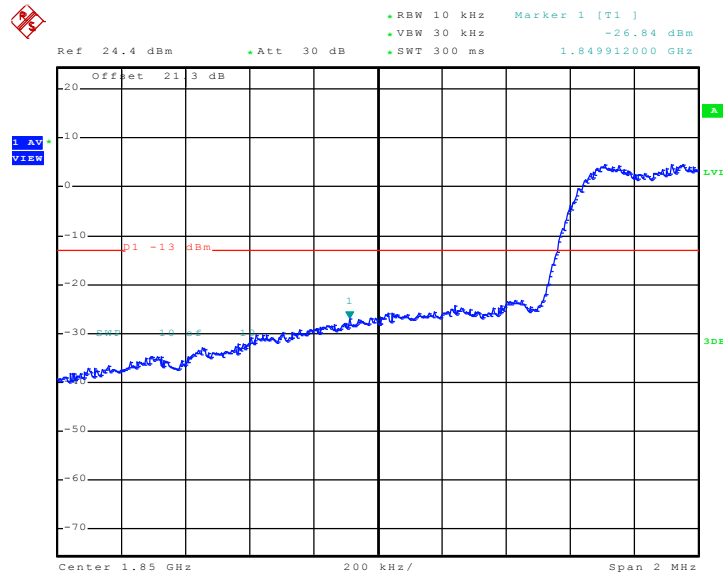

Date: 22..JAN..2010 06:49:34



Higher Band Edge Plot on Channel 1175

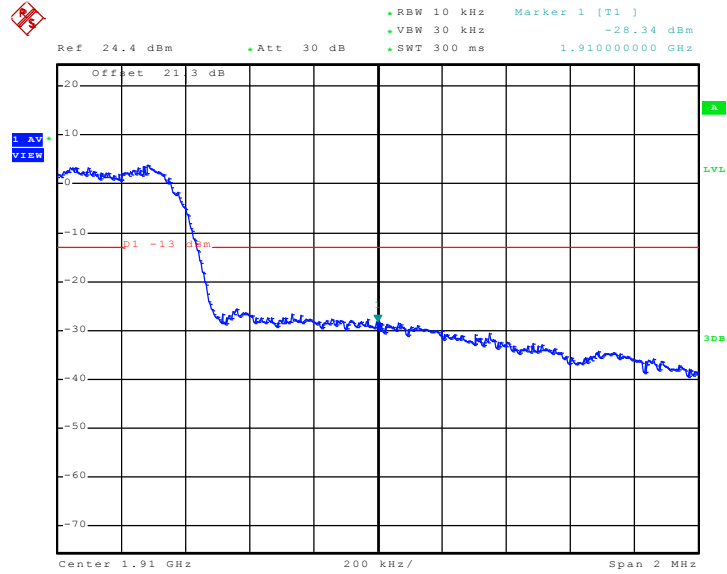

Date: 22.JAN.2010 06:51:27

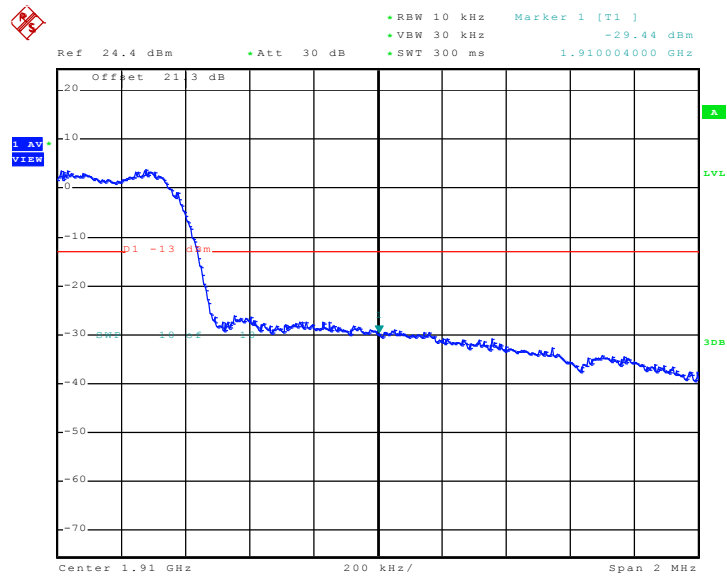

Date: 22.JAN.2010 06:50:23

## 3.5 Conducted Emission Measurement

### 3.5.1 Description of Conducted Emission Measurement

The power of any emission outside of the authorized operating frequency ranges must be lower than the transmitter power (P) by a factor of at least  $43 + 10 \log (P)$  dB.

It is measured by means of a calibrated spectrum analyzer and scanned from 30 MHz up to a frequency including its 10<sup>th</sup> harmonic.

### 3.5.2 Measuring Instruments

See list of measuring instruments of this test report.

### 3.5.3 Test Procedures

1. The EUT was connected to spectrum analyzer and base station via power divider.
2. The middle channel for the highest RF power within the transmitting frequency was measured.
3. The conducted spurious emission for the whole frequency range was taken.

### 3.5.4 Test Setup

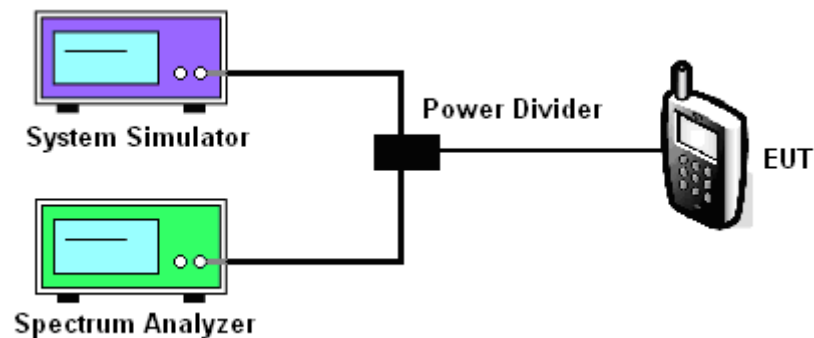





3.5.5 Test Result (Plots) of Conducted Emission

Band :	GSM850	Channel :	CH189
Test Mode :	GSM Link		

Conducted Emission Plot between 30MHz ~ 1GHz

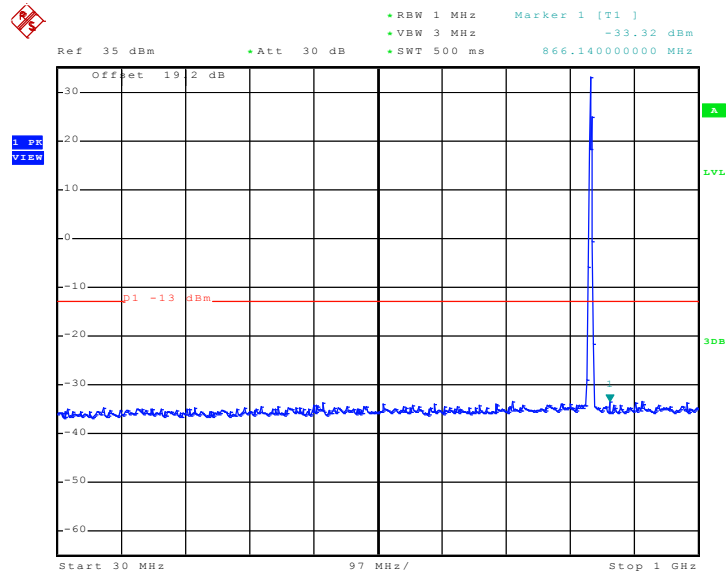

Date: 20..JAN..2010 23:24:27

Conducted Emission Plot between 1GHz ~ 3GHz

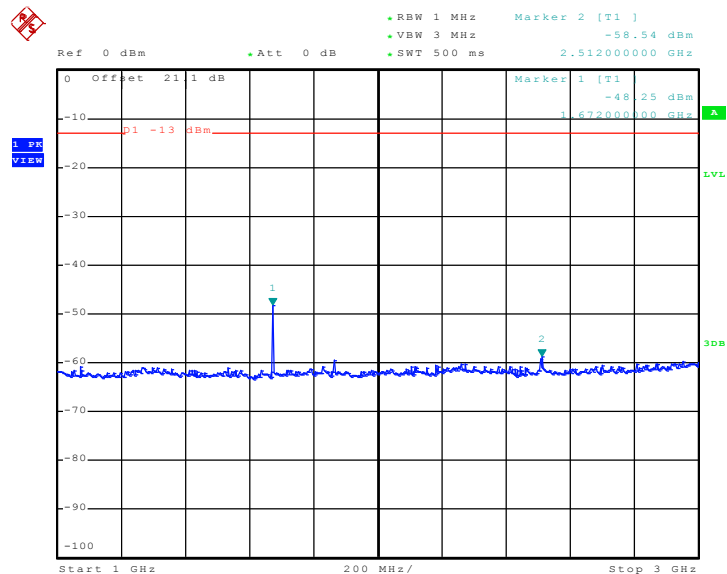

Date: 20..JAN..2010 23:25:49



Conducted Emission Plot between 3GHz ~ 7GHz

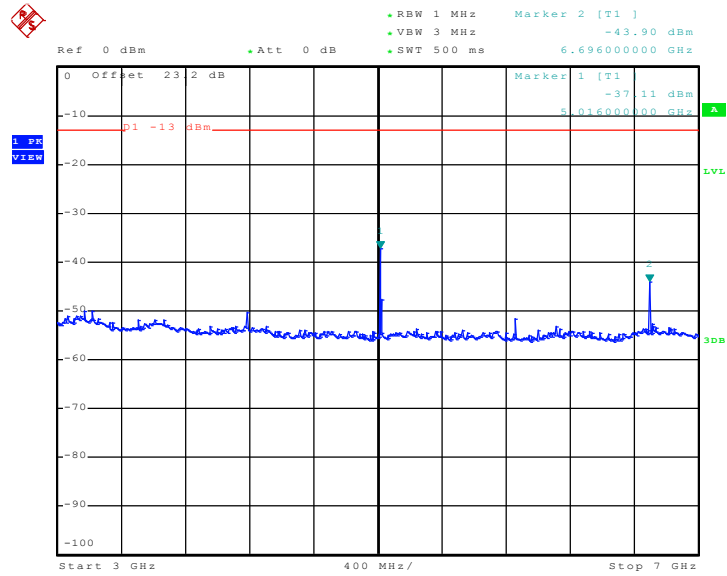

Date: 20.JAN.2010 23:28:30

Conducted Emission Plot between 7GHz ~ 9GHz

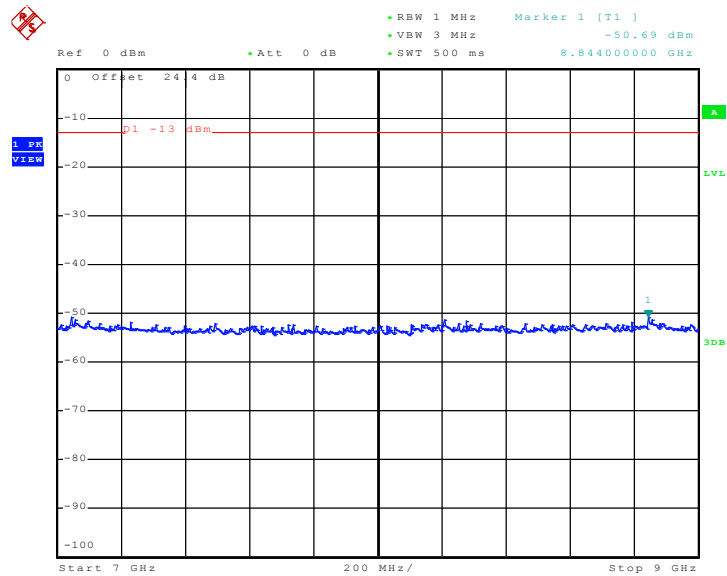

Date: 20.JAN.2010 23:29:31



Band :	GSM850	Channel :	CH189
Test Mode :	EDGE 8 Link		

Conducted Emission Plot between 30MHz ~ 1GHz

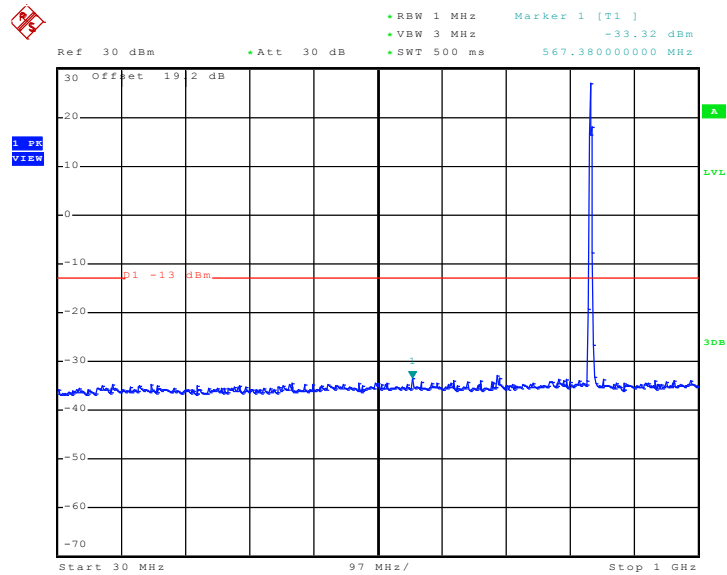

Date: 20..JAN.2010 23:21:46

Conducted Emission Plot between 1GHz ~ 3GHz

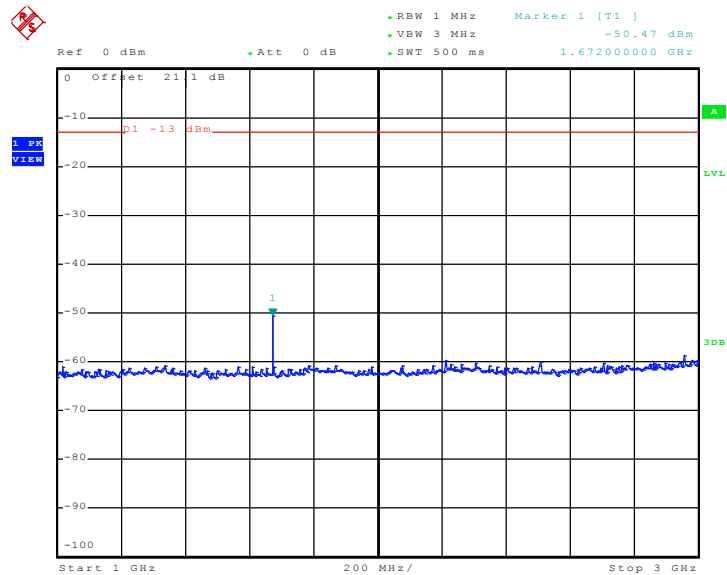

Date: 20..JAN.2010 23:26:51



Conducted Emission Plot between 3GHz ~ 7GHz

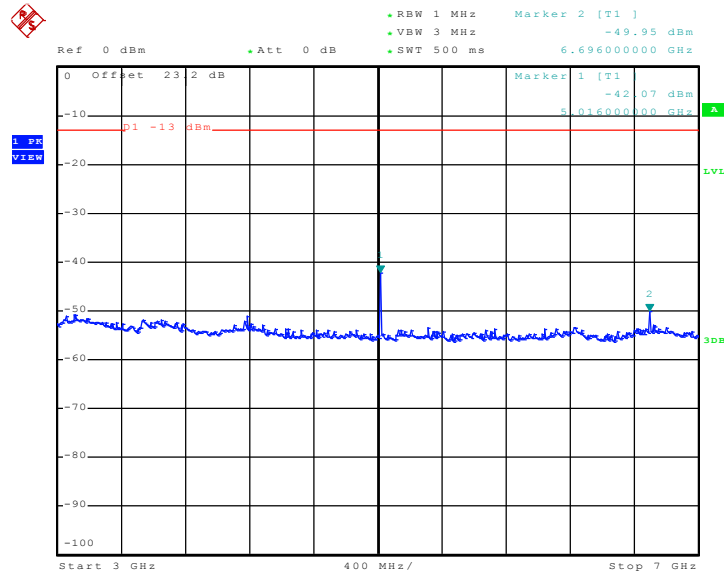

Date: 20.JAN.2010 23:27:47

Conducted Emission Plot between 7GHz ~ 9GHz

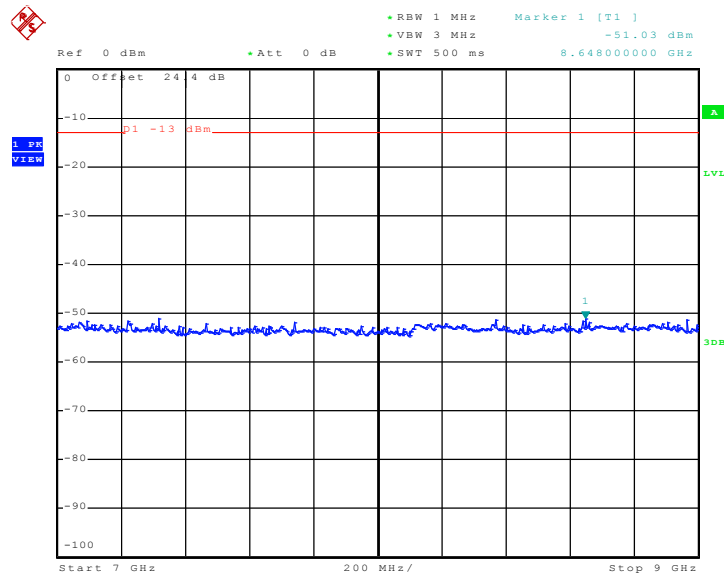

Date: 20.JAN.2010 23:30:06



Band :	GSM1900	Channel :	CH661
Test Mode :	GSM Link		

Conducted Emission Plot between 30MHz ~ 1GHz

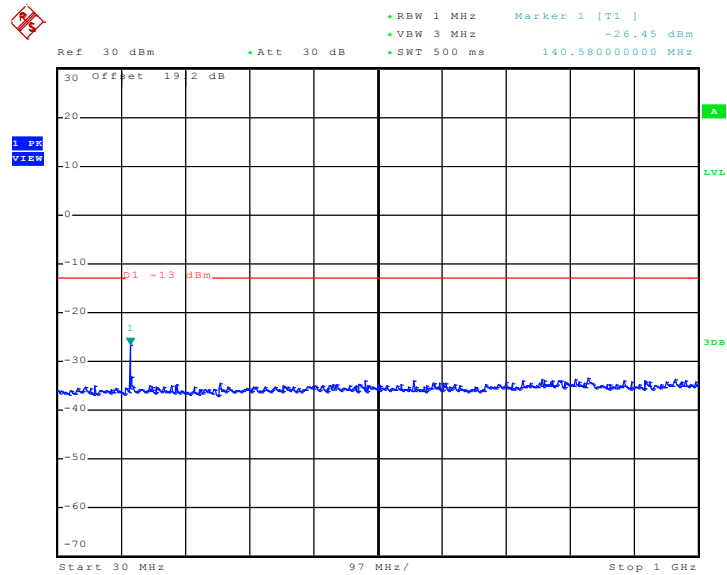

Date: 20..JAN..2010 23:34:26

Conducted Emission Plot between 1GHz ~ 3GHz

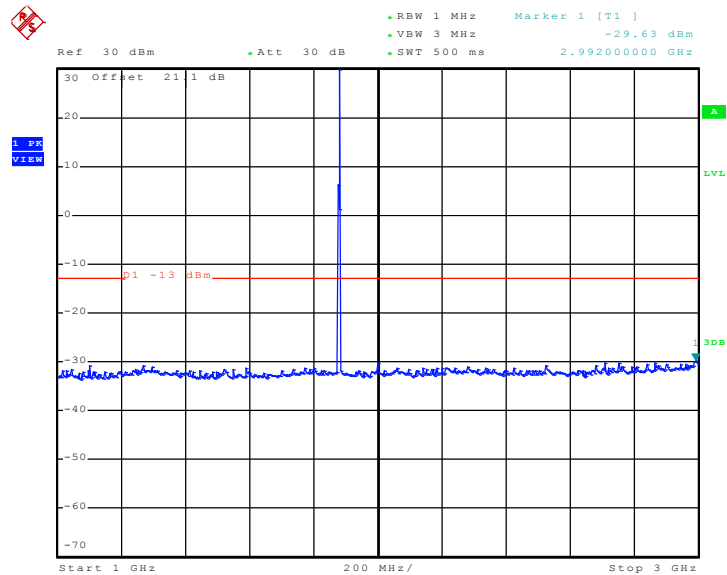

Date: 20..JAN..2010 23:40:49



Conducted Emission Plot between 3GHz ~ 7GHz

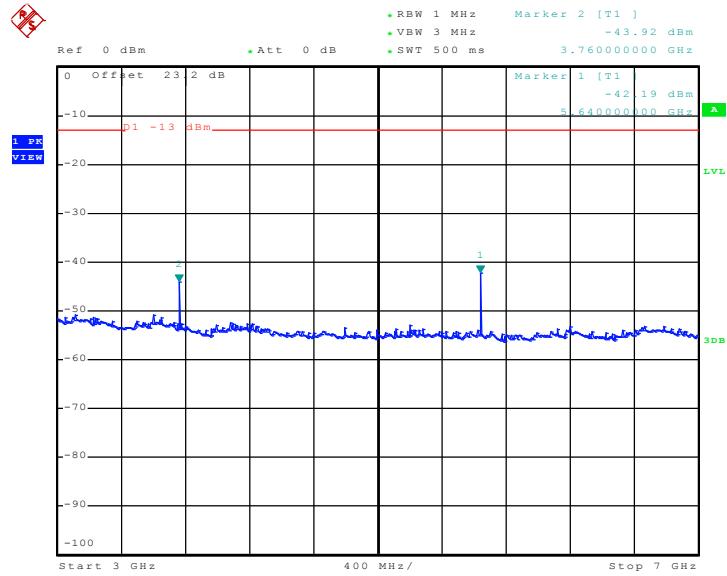

Date: 20.JAN.2010 23:42:52

Conducted Emission Plot between 7GHz ~ 13.6GHz

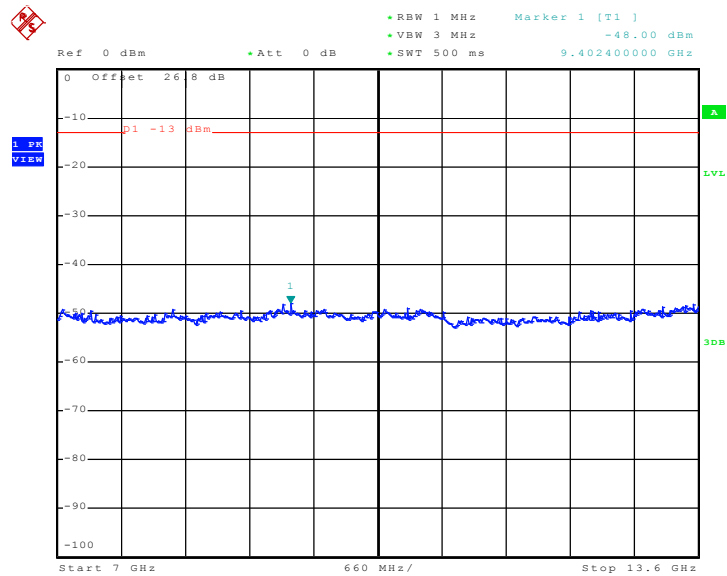

Date: 20.JAN.2010 23:45:19



Conducted Emission Plot between 13.6GHz ~ 19.1GHz

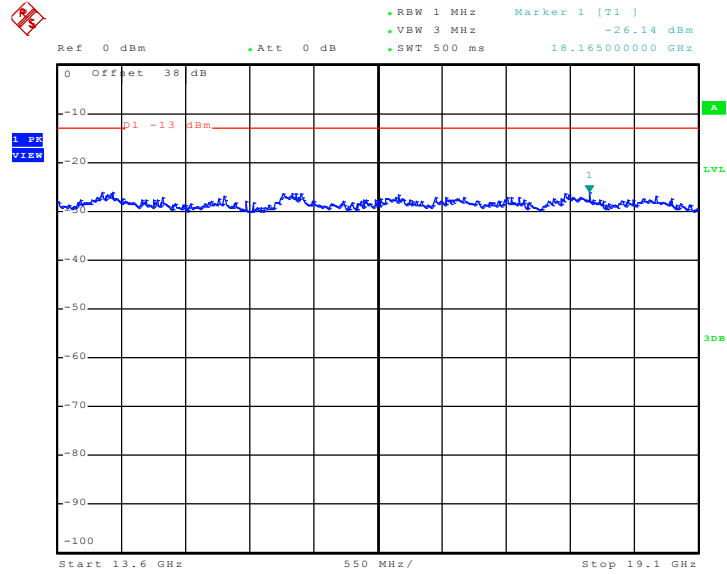

Date: 20.JAN.2010 23:46:14



Band :	GSM1900	Channel :	CH661
Test Mode :	EDGE 8 Link		

Conducted Emission Plot between 30MHz ~ 1GHz

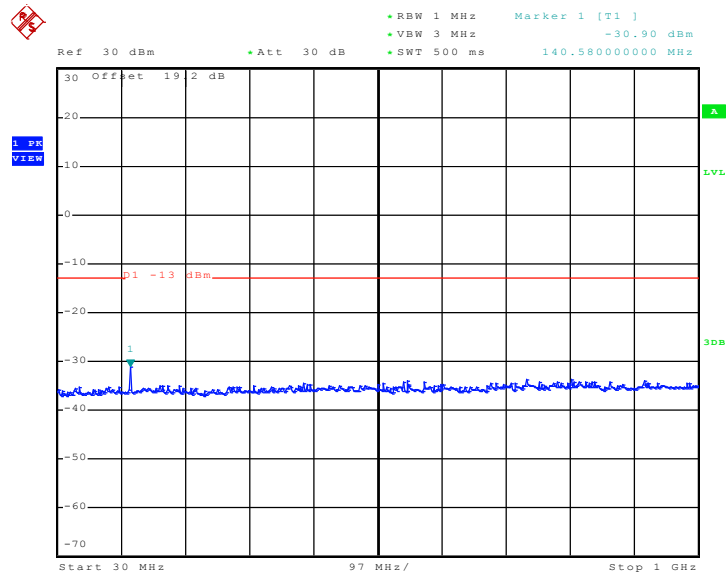

Date: 20..JAN..2010 23:34:59

Conducted Emission Plot between 1GHz ~ 3GHz

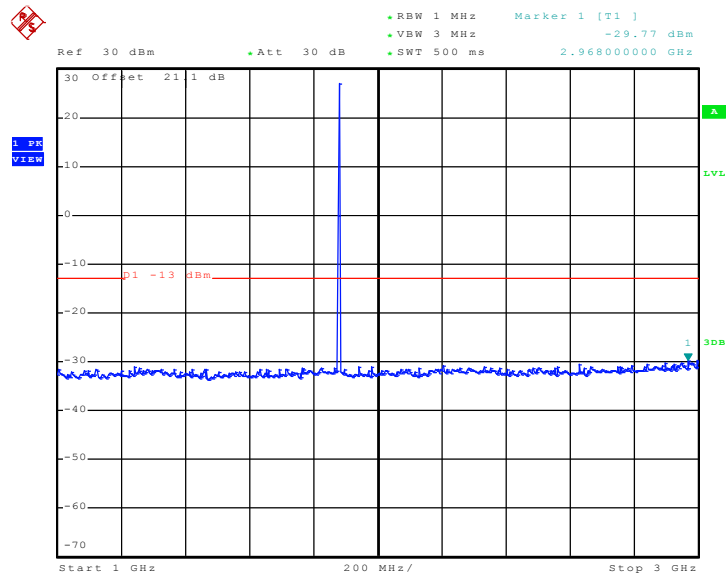

Date: 20..JAN..2010 23:38:37







Conducted Emission Plot between 13.6GHz ~ 19.1GHz

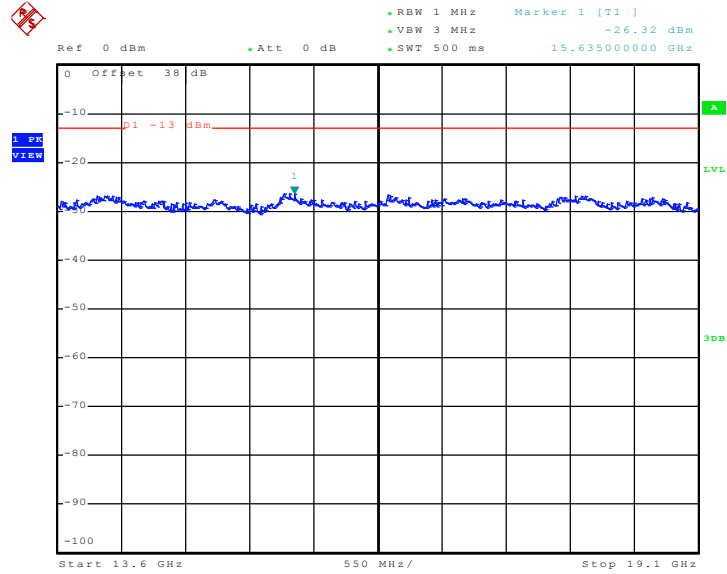

Date: 20.JAN.2010 23:46:48



Band :	WCDMA Band V	Channel :	CH4182
Test Mode :	RMC 12.2Kbps Link		

Conducted Emission Plot between 30MHz ~ 1GHz

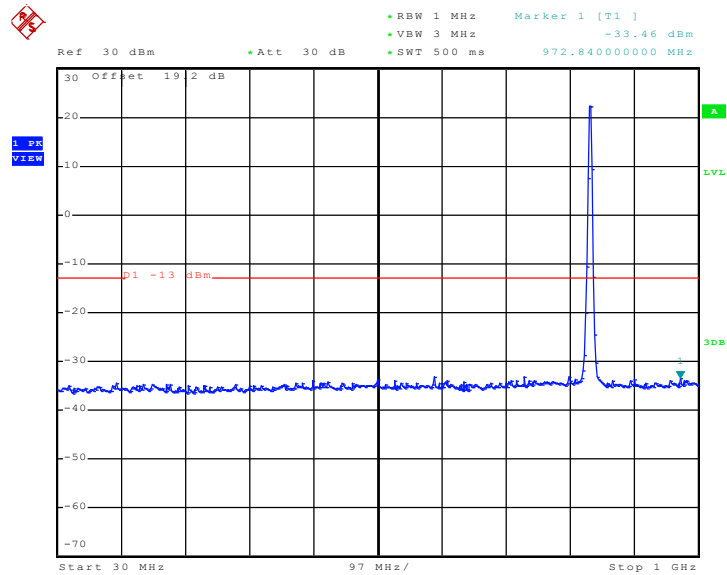

Date: 21..JAN..2010 00:04:56

Conducted Emission Plot between 1GHz ~ 3GHz

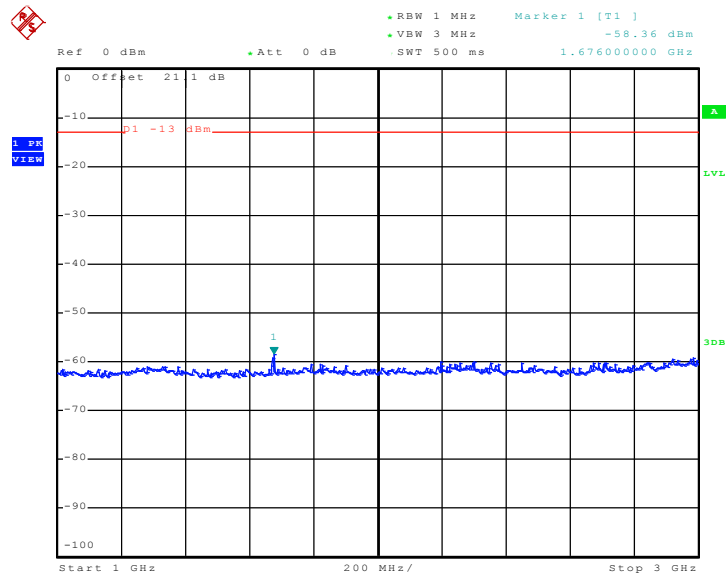

Date: 21..JAN..2010 00:09:23



Conducted Emission Plot between 3GHz ~ 7GHz

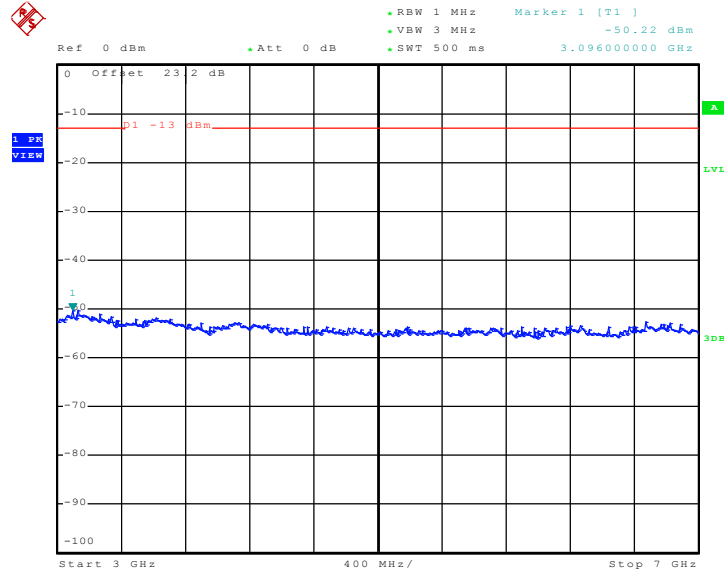

Date: 21.JAN.2010 00:10:38

Conducted Emission Plot between 7GHz ~ 9GHz

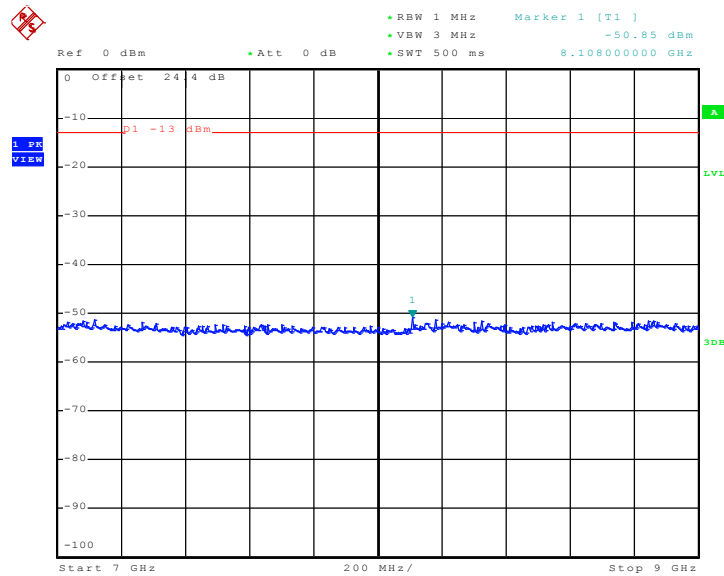

Date: 21.JAN.2010 00:11:39



Band :	WCDMA Band II	Channel :	CH9400
Test Mode :	RMC 12.2Kbps Link		

Conducted Emission Plot between 30MHz ~ 1GHz

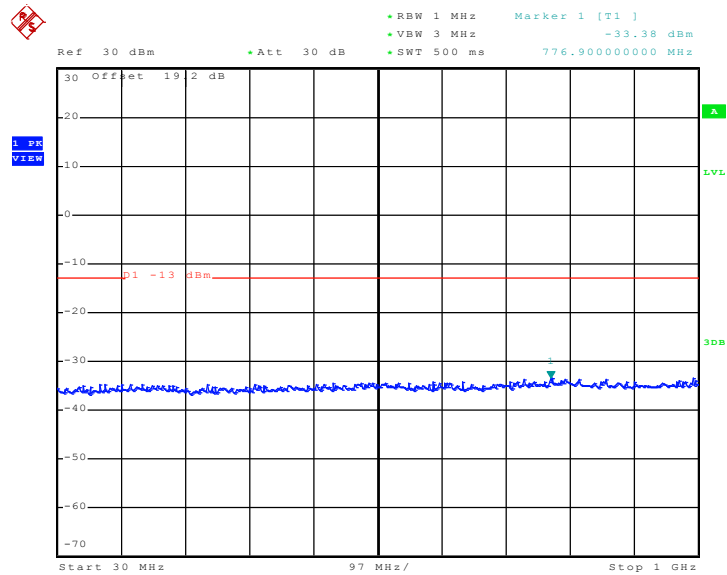

Date: 21..JAN..2010 00:02:25

Conducted Emission Plot between 1GHz ~ 3GHz

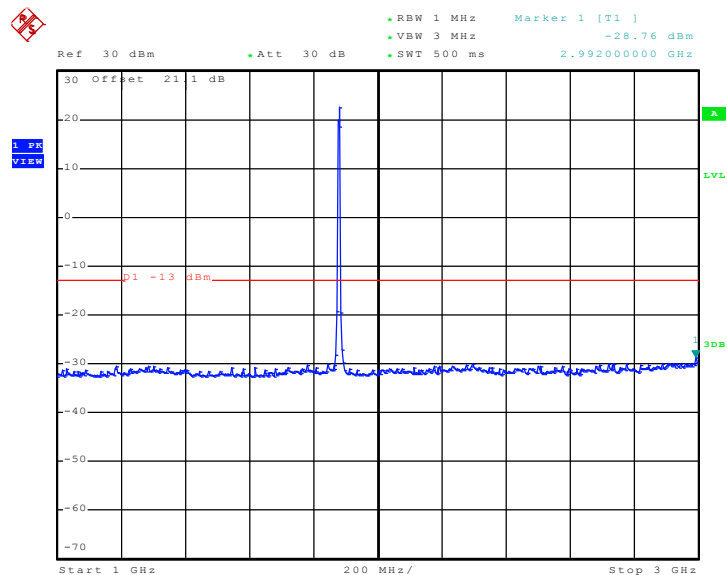

Date: 21..JAN..2010 00:01:36



Conducted Emission Plot between 3GHz ~ 7GHz

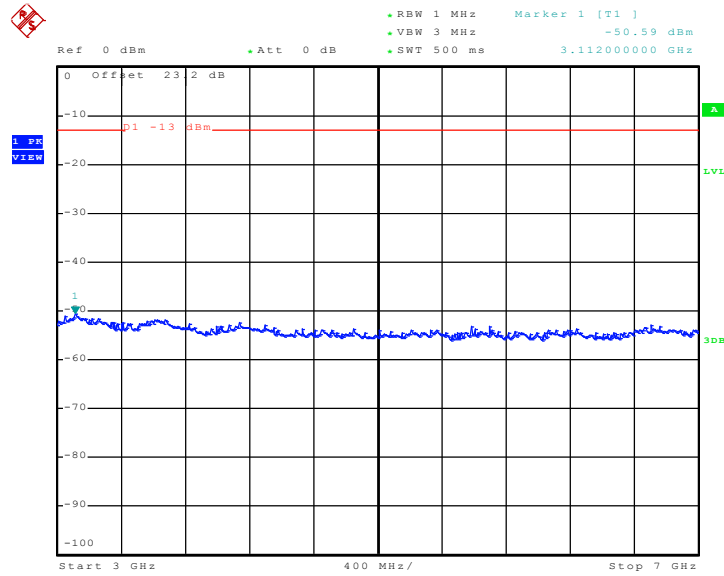

Date: 20.JAN.2010 23:59:20

Conducted Emission Plot between 7GHz ~ 13.6GHz

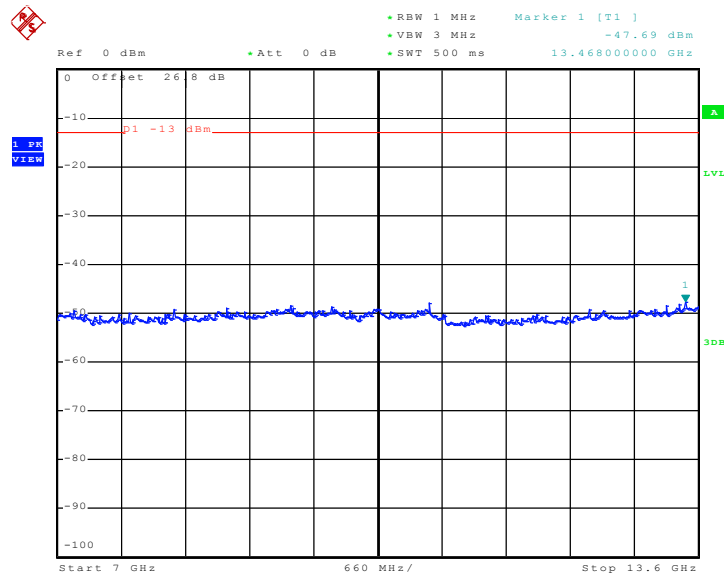

Date: 20.JAN.2010 23:58:19



Conducted Emission Plot between 13.6GHz ~ 19.1GHz

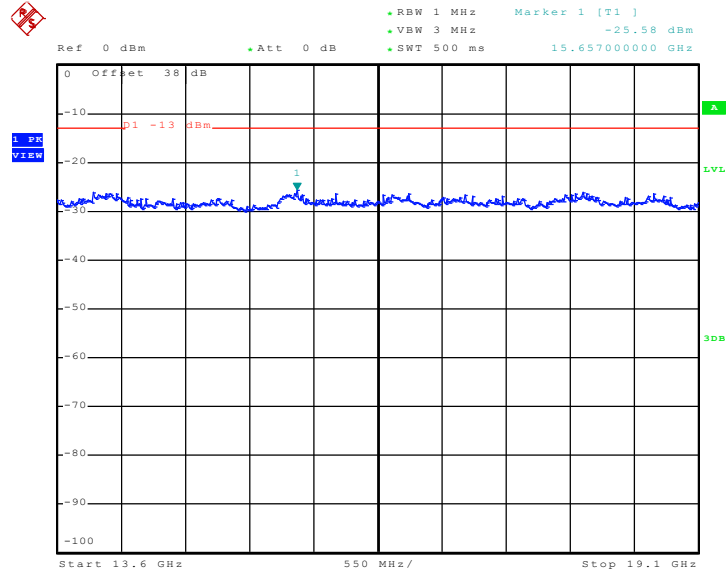

Date: 20.JAN.2010 23:57:24



Band :	CDMA2000 BC0	Power Stage :	High
Test Mode :	1xRTT FCH_RC3+SO55 Link		

Conducted Emission Plot between 30MHz ~ 1GHz

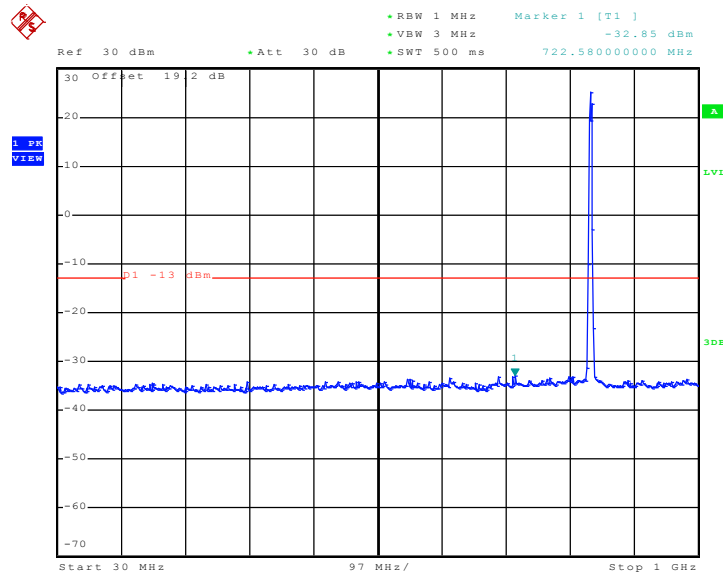

Date: 21..JAN..2010 01:53:34

Conducted Emission Plot between 1GHz ~ 3GHz

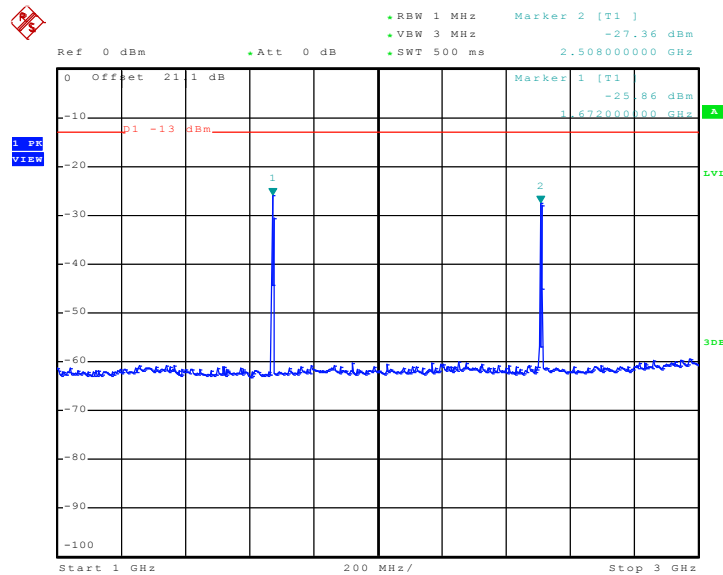

Date: 21..JAN..2010 02:42:30





Conducted Emission Plot between 3GHz ~ 7GHz

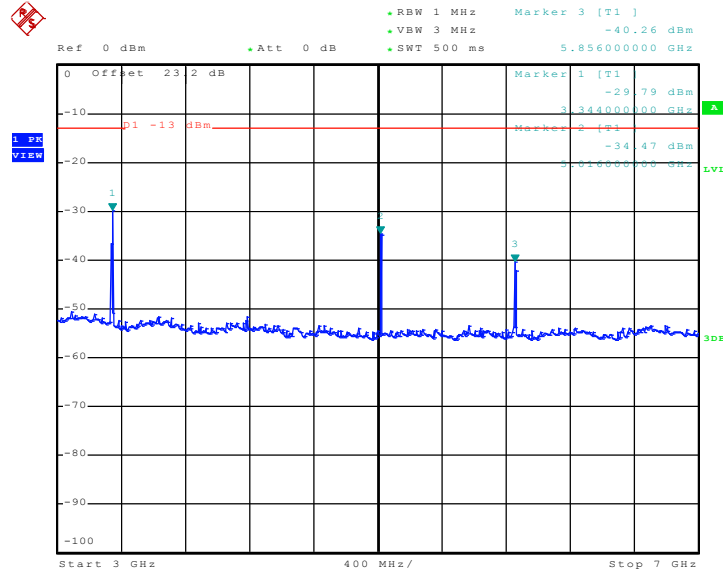

Date: 21.JAN.2010 02:43:29

Conducted Emission Plot between 7GHz ~ 9GHz

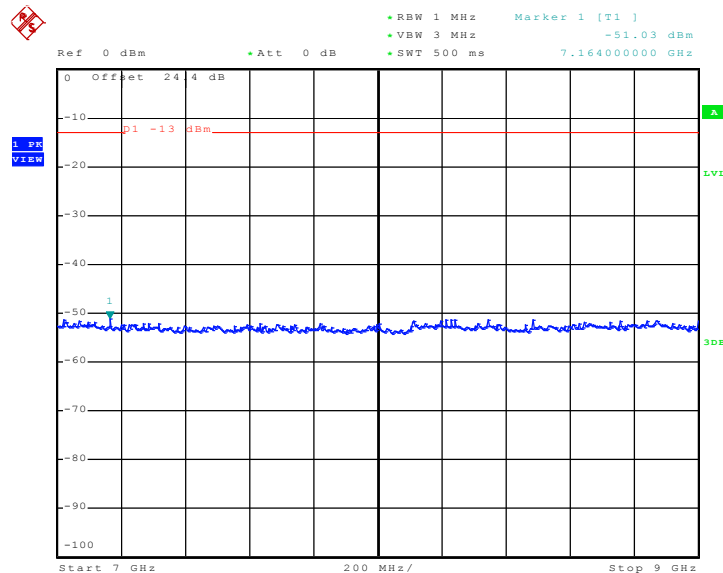

Date: 21.JAN.2010 02:47:22



Band :	CDMA2000 BC1	Power Stage :	High
Test Mode :	1xRTT FCH_RC3+SO55 Link		

Conducted Emission Plot between 30MHz ~ 1GHz

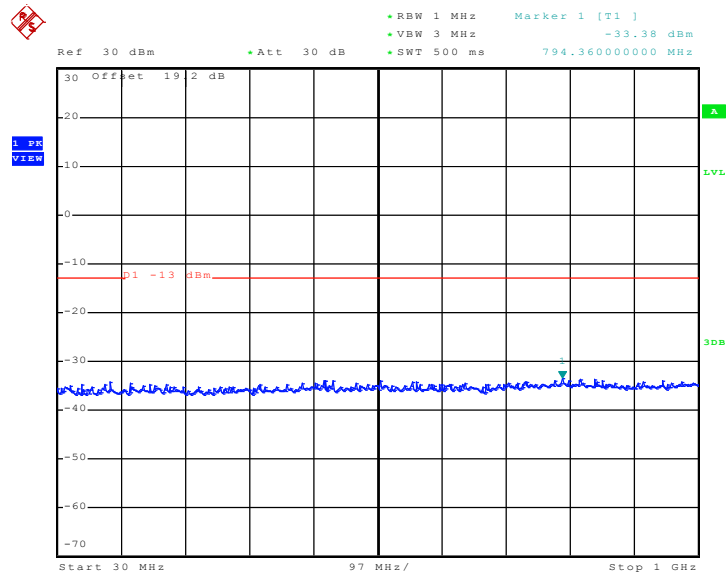

Date: 21..JAN..2010 01:54:11

Conducted Emission Plot between 1GHz ~ 3GHz

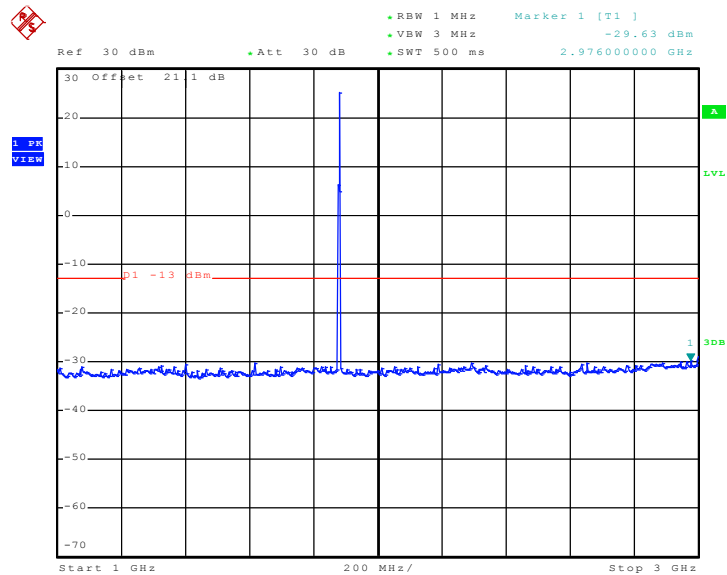

Date: 21..JAN..2010 01:55:45



Conducted Emission Plot between 3GHz ~ 7GHz

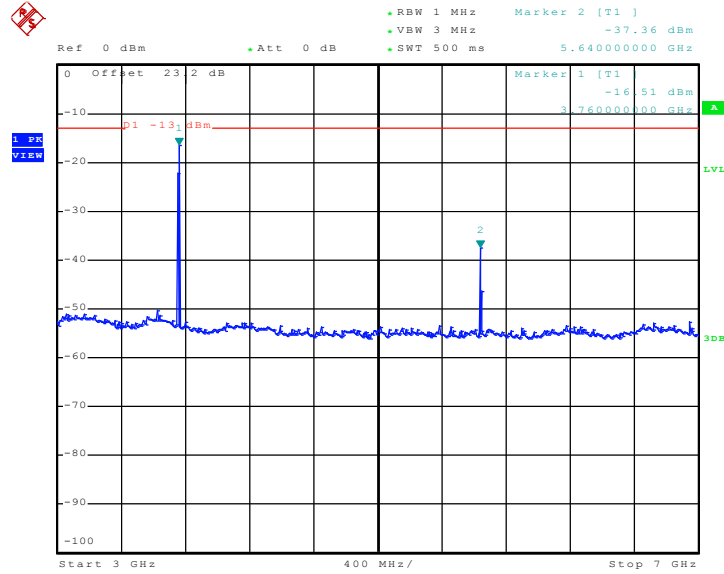

Date: 21.JAN.2010 02:44:59

Conducted Emission Plot between 7GHz ~ 13.6GHz

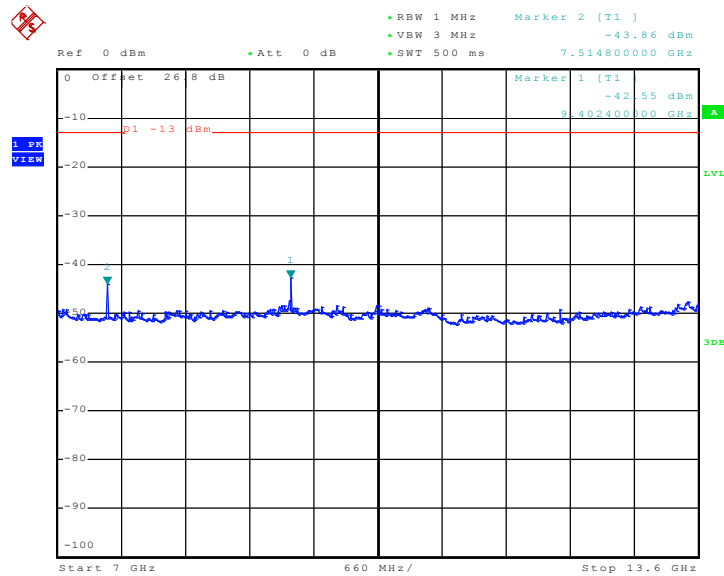

Date: 21.JAN.2010 02:46:15



Conducted Emission Plot between 13.6GHz ~ 19.1GHz

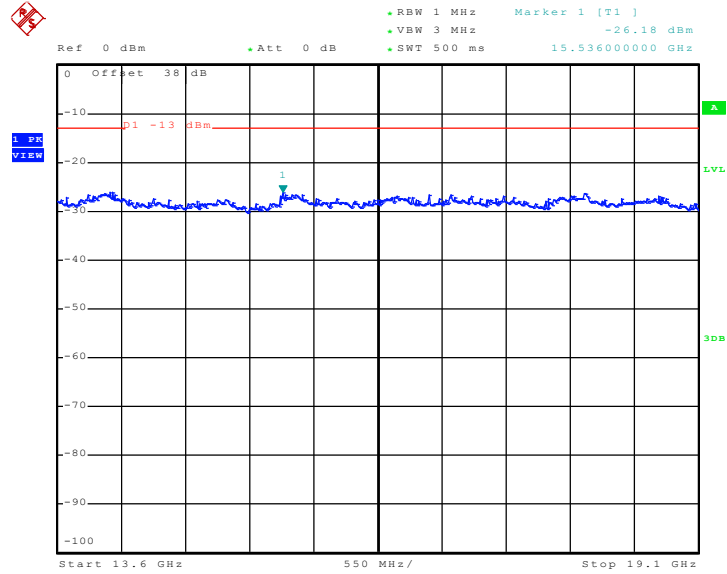

Date: 21.JAN.2010 02:48:38

## 3.6 Field Strength of Spurious Radiation Measurement

### 3.6.1 Description of Field Strength of Spurious Radiated Measurement

The radiated spurious emission was measured by substitution method according to ANSI / TIA / EIA-603-C-2004. The power of any emission outside of the authorized operating frequency ranges must be attenuated below the transmitter power (P) by a factor of at least  $43 + 10 \log (P)$  dB. The spectrum is scanned from 30 MHz up to a frequency including its 10th harmonic.

### 3.6.2 Measuring Instruments

See list of measuring instruments of this test report.

### 3.6.3 Test Procedures

4. The EUT was placed on a rotatable wooden table with 0.8 meter about ground.
5. The EUT was set 3 meters from the receiving antenna, which was mounted on the antenna tower.
6. The table was rotated 360 degrees to determine the position of the highest spurious emission.
7. The height of the receiving antenna is varied between one meter and four meters to search the maximum spurious emission for both horizontal and vertical polarizations.
8. Make the measurement with the spectrum analyzer's RBW = 1MHz, VBW = 3MHz, Sweep = 500ms, Taking the record of maximum spurious emission.
9. A horn antenna was substituted in place of the EUT and was driven by a signal generator.
10. Tune the output power of signal generator to the same emission level with EUT maximum spurious emission.
11. Taking the record of output power at antenna port.
12. Repeat step 7 to step 8 for another polarization.
13.  $EIRP \text{ (dBm)} = S.G. \text{ Power} - Tx \text{ Cable Loss} + Tx \text{ Antenna Gain}$
14.  $ERP \text{ (dBm)} = EIRP - 2.15$

### 3.6.4 Test Setup

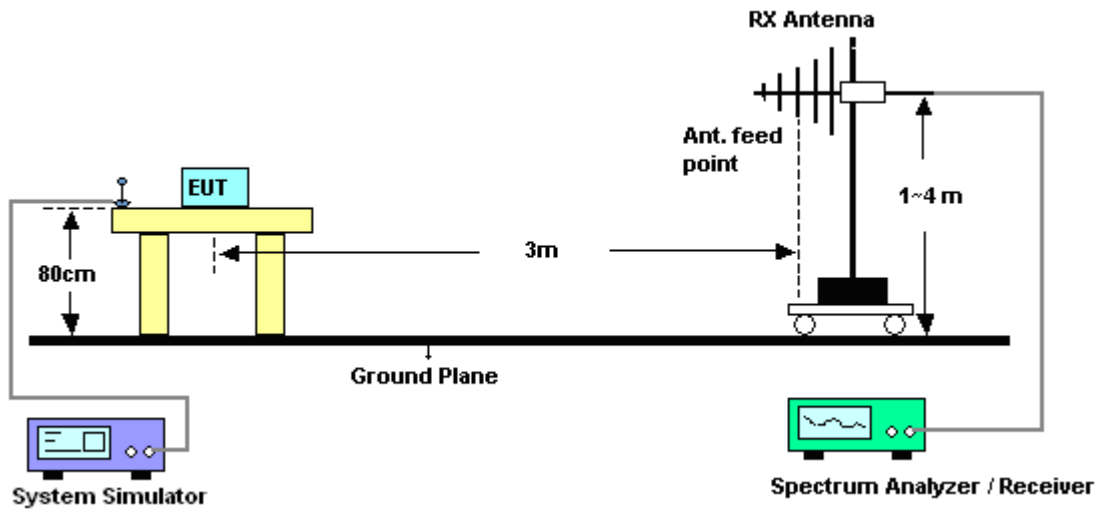



3.6.5 Test Result of Field Strength of Spurious Radiated

Band :	GSM850	Temperature :	23~25°C
Test Mode :	GSM Link + Qwerty Keypad	Relative Humidity :	50~54%
Test Engineer :	Cona Huang	Polarization :	Horizontal
Remark :	Spurious emissions within 30-1000MHz were found more than 20dB below limit line.		

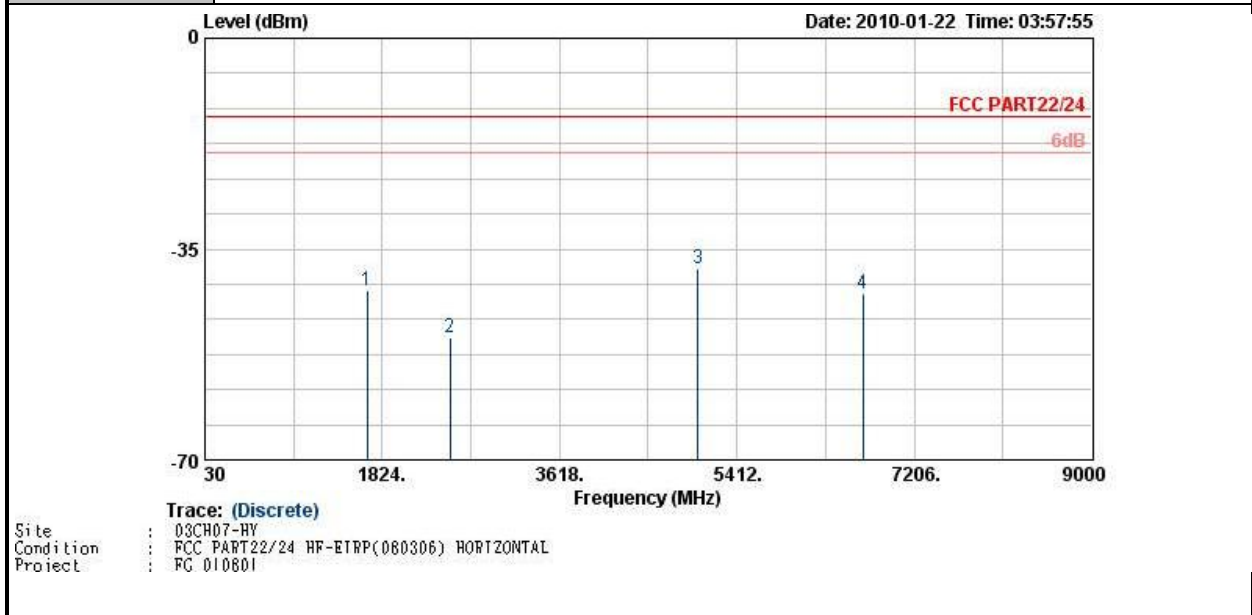

Frequency ( MHz )	ERP ( dBm )	Limit ( dBm )	Over Limit ( dB )	SPA Reading ( dBm )	S.G. Power ( dBm )	TX Cable loss ( dB )	TX Antenna Gain ( dBi )	Polarization ( H/V )	Result
1669	-41.78	-13	-28.78	-50.17	-41.63	3.39	5.39	H	Pass
2509	-49.71	-13	-36.71	-59.85	-49.97	3.71	6.12	H	Pass
5015	-38.20	-13	-25.20	-54.44	-43.17	2.61	9.73	H	Pass
6690	-42.54	-13	-29.54	-64.35	-46.32	5.22	11.15	H	Pass



<b>Band :</b>	GSM850	<b>Temperature :</b>	23~25°C
<b>Test Mode :</b>	GSM Link + Qwerty Keypad	<b>Relative Humidity :</b>	50~54%
<b>Test Engineer :</b>	Cona Huang	<b>Polarization :</b>	Vertical
<b>Remark :</b>	Spurious emissions within 30-1000MHz were found more than 20dB below limit line.		

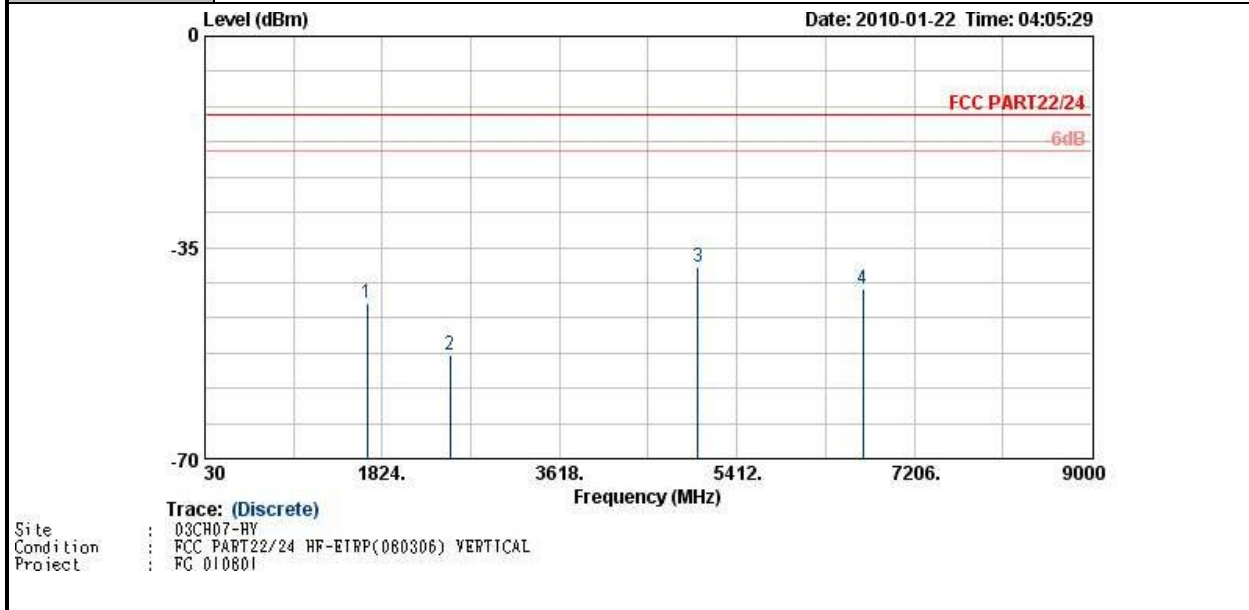

Frequency (MHz)	ERP (dBm)	Limit (dBm)	Over Limit (dB)	SPA Reading (dBm)	S.G. Power (dBm)	TX Cable loss (dB)	TX Antenna Gain (dBi)	Polarization (H/V)	Result
1669	-44.26	-13	-31.26	-52.26	-44.11	3.39	5.39	V	Pass
2509	-52.90	-13	-39.90	-63.49	-53.16	3.71	6.12	V	Pass
5015	-38.22	-13	-25.22	-54.99	-43.19	2.61	9.73	V	Pass
6690	-41.88	-13	-28.88	-63.1	-45.66	5.22	11.15	V	Pass





Band :	GSM850	Temperature :	23~25°C
Test Mode :	EDGE 8 Link + Qwerty Keypad	Relative Humidity :	50~54%
Test Engineer :	Cona Huang	Polarization :	Horizontal
Remark :	Spurious emissions within 30-1000MHz were found more than 20dB below limit line.		

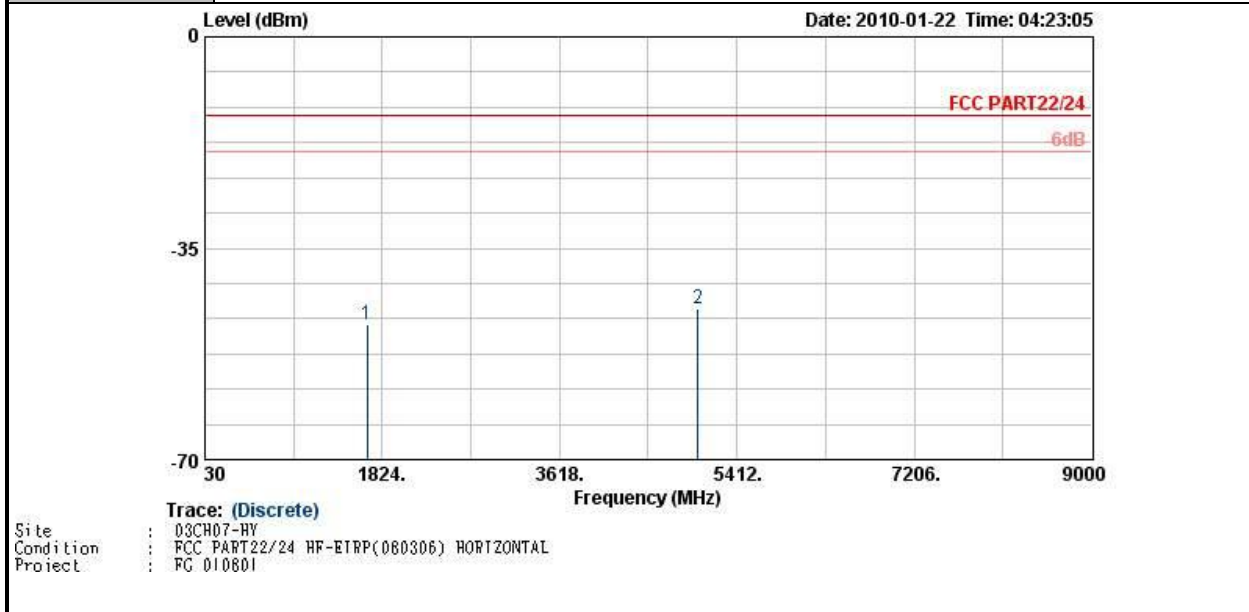

Frequency ( MHz )	ERP ( dBm )	Limit ( dBm )	Over Limit ( dB )	SPA Reading ( dBm )	S.G. Power ( dBm )	TX Cable loss ( dB )	TX Antenna Gain ( dBi )	Polarization ( H/V )	Result
1669	-47.59	-13	-34.59	-54.94	-47.44	3.39	5.39	H	Pass
5015	-45.09	-13	-32.09	-59.84	-50.06	2.61	9.73	H	Pass



<b>Band :</b>	GSM850	<b>Temperature :</b>	23~25°C
<b>Test Mode :</b>	EDGE 8 Link + Qwerty Keypad	<b>Relative Humidity :</b>	50~54%
<b>Test Engineer :</b>	Cona Huang	<b>Polarization :</b>	Vertical
<b>Remark :</b>	Spurious emissions within 30-1000MHz were found more than 20dB below limit line.		

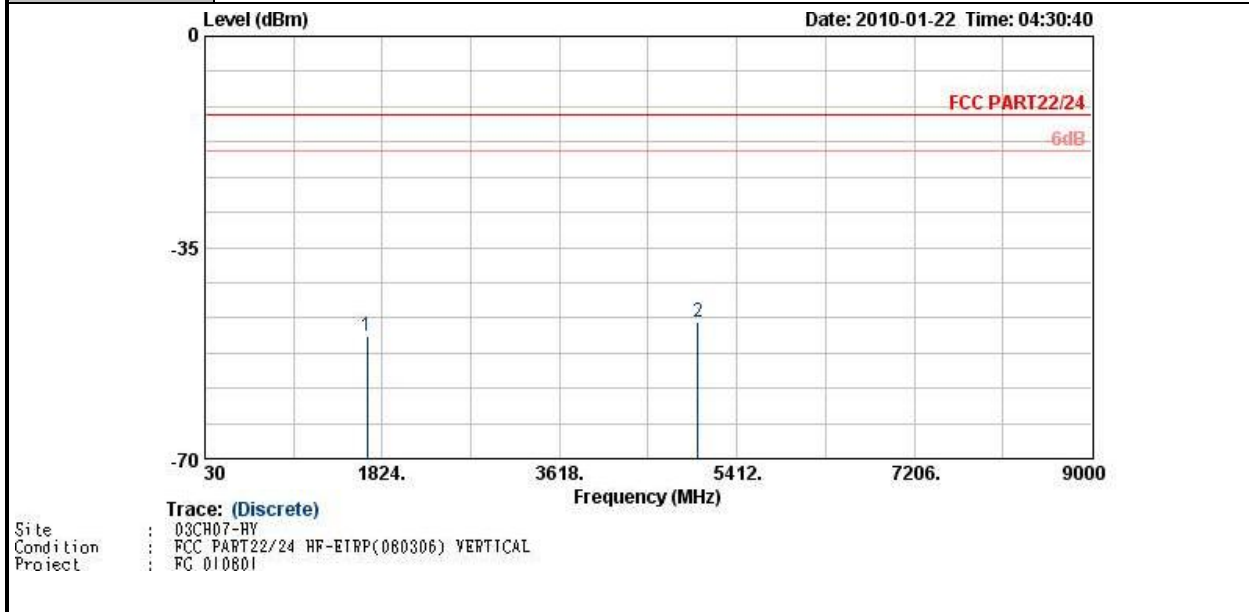

Frequency ( MHz )	ERP ( dBm )	Limit ( dBm )	Over Limit ( dB )	SPA Reading ( dBm )	S.G. Power ( dBm )	TX Cable loss ( dB )	TX Antenna Gain ( dBi )	Polarization ( H/V )	Result
1669	-49.79	-13	-36.79	-57.04	-49.64	3.39	5.39	V	Pass
5015	-47.33	-13	-34.33	-62.24	-52.3	2.61	9.73	V	Pass



<b>Band :</b>	GSM850	<b>Temperature :</b>	23~25°C
<b>Test Mode :</b>	GSM Link + 802.11a Tx CH165 + Qwerty Keypad	<b>Relative Humidity :</b>	50~54%
<b>Test Engineer :</b>	Cona Huang	<b>Polarization :</b>	Horizontal
<b>Remark :</b>	Spurious emissions within 30-1000MHz were found more than 20dB below limit line.		

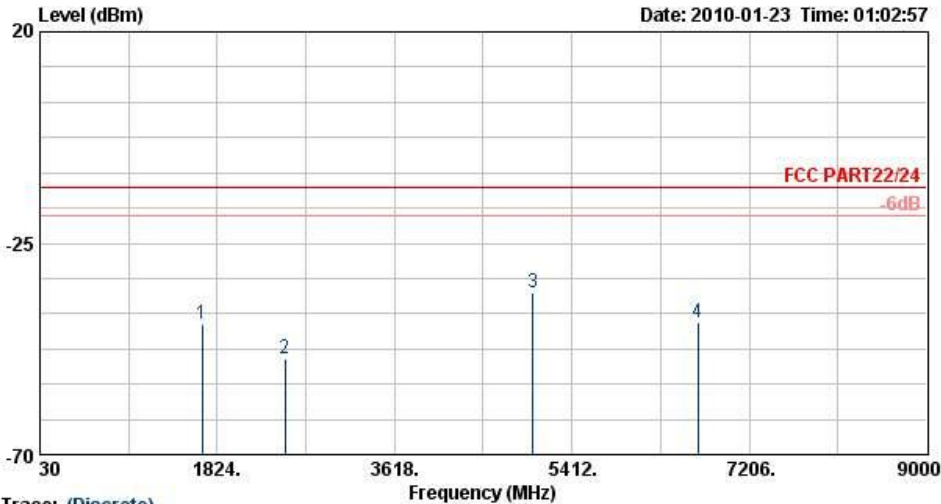

Trace: (Discrete)  
 Site : 03CH07-HY  
 Condition : FCC PART22/24 HF-ETRP(080306) HORIZONTAL  
 Project : FG 010801

Frequency (MHz)	ERP (dBm)	Limit (dBm)	Over Limit (dB)	SPA Reading (dBm)	S.G. Power (dBm)	TX Cable loss (dB)	TX Antenna Gain (dBi)	Polarization (H/V)	Result
1669	-42.20	-13	-29.20	-50.59	-42.05	3.39	5.39	H	Pass
2509	-49.56	-13	-36.56	-59.7	-49.82	3.71	6.12	H	Pass
5015	-35.51	-13	-22.51	-52.25	-40.48	2.61	9.73	H	Pass
6690	-42.02	-13	-29.02	-63.83	-45.8	5.22	11.15	H	Pass



<b>Band :</b>	GSM850	<b>Temperature :</b>	23~25°C
<b>Test Mode :</b>	GSM Link + 802.11a Tx CH165 + Qwerty Keypad	<b>Relative Humidity :</b>	50~54%
<b>Test Engineer :</b>	Cona Huang	<b>Polarization :</b>	Vertical
<b>Remark :</b>	Spurious emissions within 30-1000MHz were found more than 20dB below limit line.		

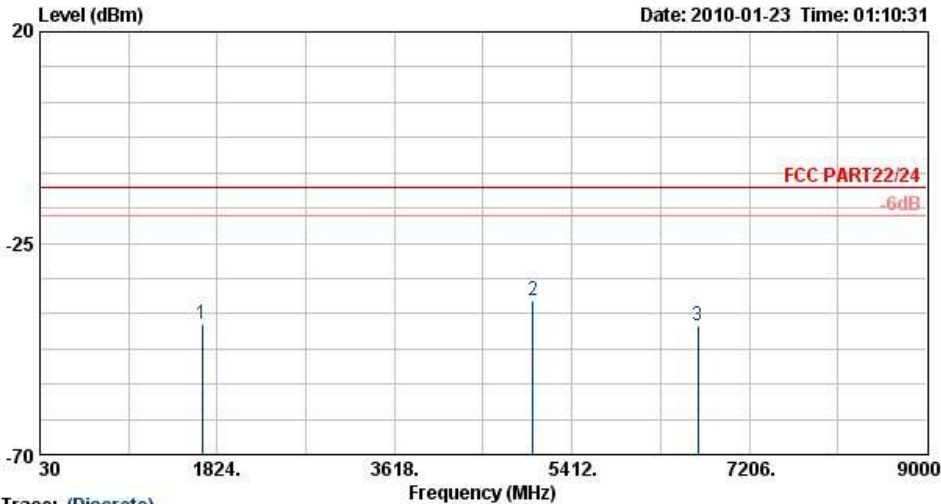

Trace: (Discrete)  
 Site : 03CH07-HY  
 Condition : FCC PART22/24 HF-ETRP(080306) VERTICAL  
 Project : FG 010801

Frequency ( MHz )	ERP ( dBm )	Limit ( dBm )	Over Limit ( dB )	SPA Reading ( dBm )	S.G. Power ( dBm )	TX Cable loss ( dB )	TX Antenna Gain ( dBi )	Polarization ( H/V )	Result
1669	-42.23	-13	-29.23	-50.85	-42.08	3.39	5.39	V	Pass
5015	-37.29	-13	-24.29	-53.99	-42.26	2.61	9.73	V	Pass
6690	-42.40	-13	-29.40	-63.62	-46.18	5.22	11.15	V	Pass



<b>Band :</b>	GSM1900	<b>Temperature :</b>	23~25°C
<b>Test Mode :</b>	GSM Link + Qwerty Keypad	<b>Relative Humidity :</b>	50~54%
<b>Test Engineer :</b>	Cona Huang	<b>Polarization :</b>	Horizontal
<b>Remark :</b>	Spurious emissions within 30-1000MHz were found more than 20dB below limit line.		

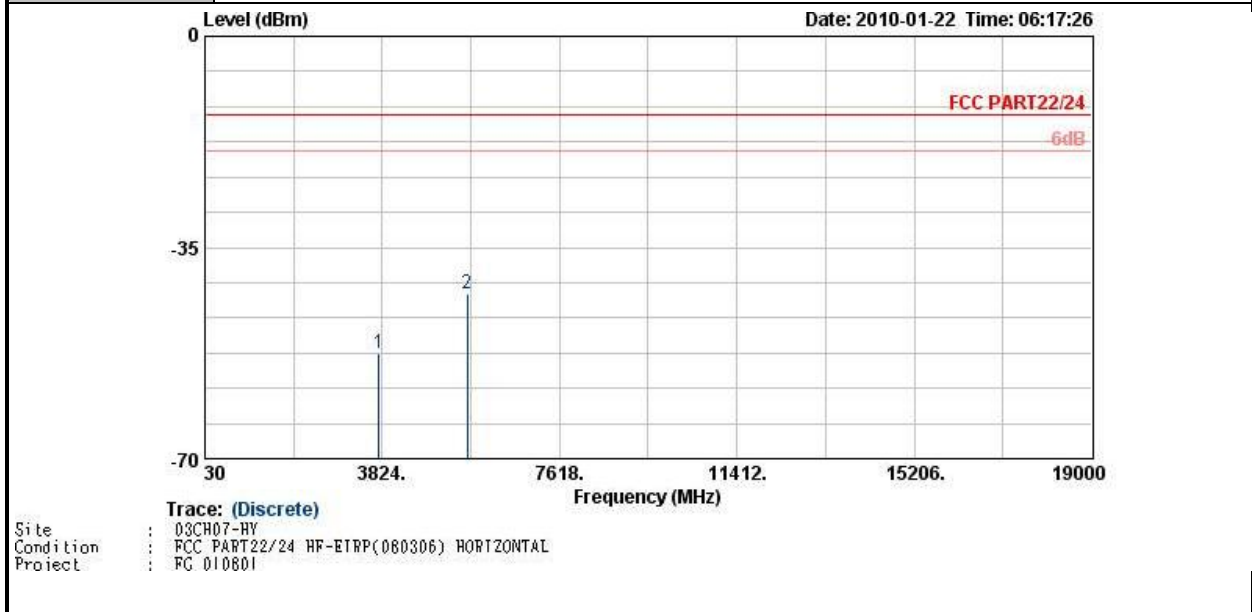

Frequency ( MHz )	EIRP ( dBm )	Limit ( dBm )	Over Limit ( dB )	SPA Reading ( dBm )	S.G. Power ( dBm )	TX Cable loss ( dB )	TX Antenna Gain ( dBi )	Polarization ( H/V )	Result
3760	-52.51	-13	-39.51	-63.03	-55.03	4.88	7.40	H	Pass
5636	-42.57	-13	-29.57	-61.24	-45.83	5.55	8.81	H	Pass



<b>Band :</b>	GSM1900	<b>Temperature :</b>	23~25°C
<b>Test Mode :</b>	GSM Link + Qwerty Keypad	<b>Relative Humidity :</b>	50~54%
<b>Test Engineer :</b>	Cona Huang	<b>Polarization :</b>	Vertical
<b>Remark :</b>	Spurious emissions within 30-1000MHz were found more than 20dB below limit line.		

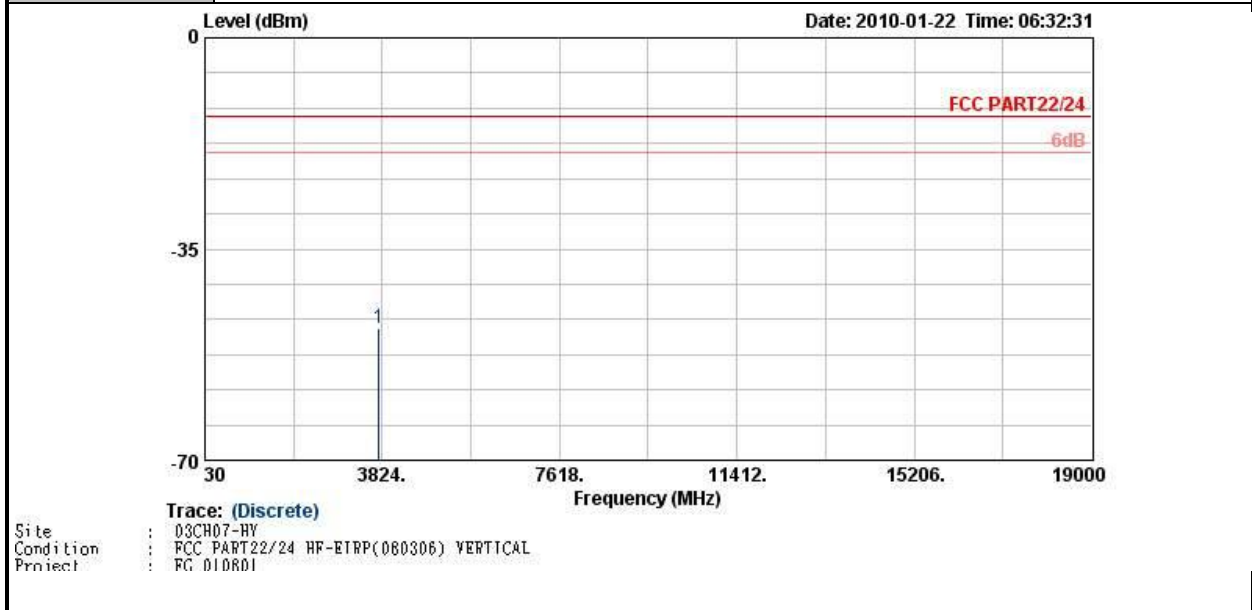

Frequency (MHz)	EIRP (dBm)	Limit (dBm)	Over Limit (dB)	SPA Reading (dBm)	S.G. Power (dBm)	TX Cable loss (dB)	TX Antenna Gain (dBi)	Polarization (H/V)	Result
3760	-48.03	-13	-35.03	-62.68	-51.06	4.88	7.91	V	Pass



<b>Band :</b>	GSM1900	<b>Temperature :</b>	23~25°C
<b>Test Mode :</b>	EDGE 8 Link + Qwerty Keypad	<b>Relative Humidity :</b>	50~54%
<b>Test Engineer :</b>	Cona Huang	<b>Polarization :</b>	Horizontal
<b>Remark :</b>	Spurious emissions within 30-1000MHz were found more than 20dB below limit line, and within 1000MHz ~ 10th harmonic were not found any signals.		

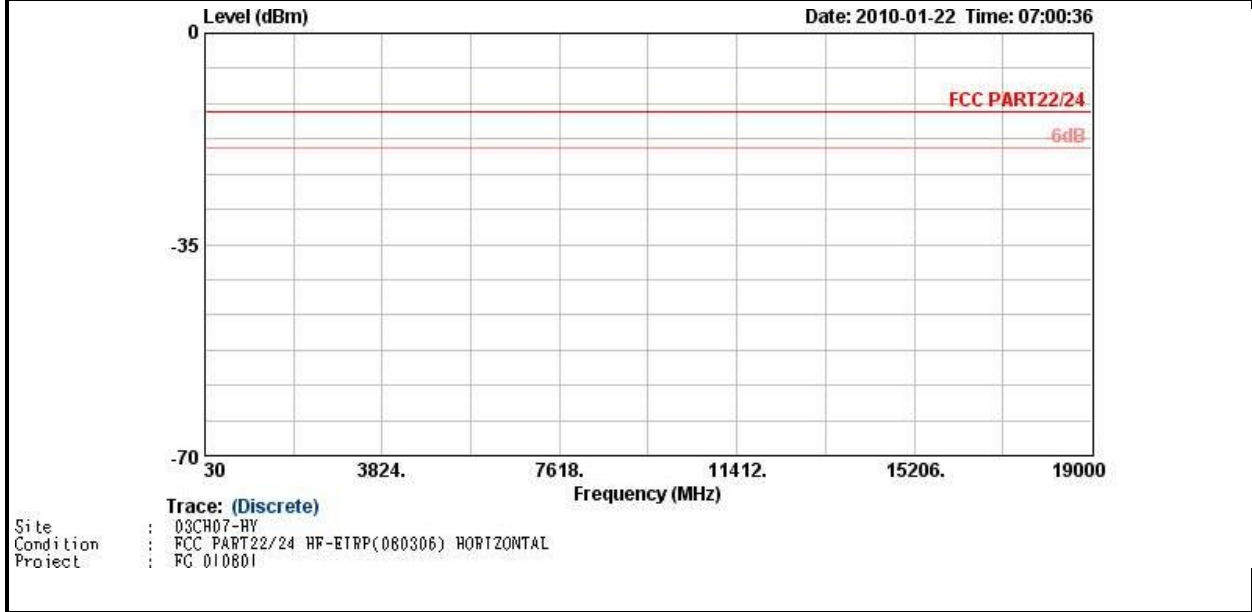



<b>Band :</b>	GSM1900	<b>Temperature :</b>	23~25°C
<b>Test Mode :</b>	EDGE 8 Link + Qwerty Keypad	<b>Relative Humidity :</b>	50~54%
<b>Test Engineer :</b>	Cona Huang	<b>Polarization :</b>	Vertical
<b>Remark :</b>	Spurious emissions within 30-1000MHz were found more than 20dB below limit line, and within 1000MHz ~ 10th harmonic were not found any signals.		

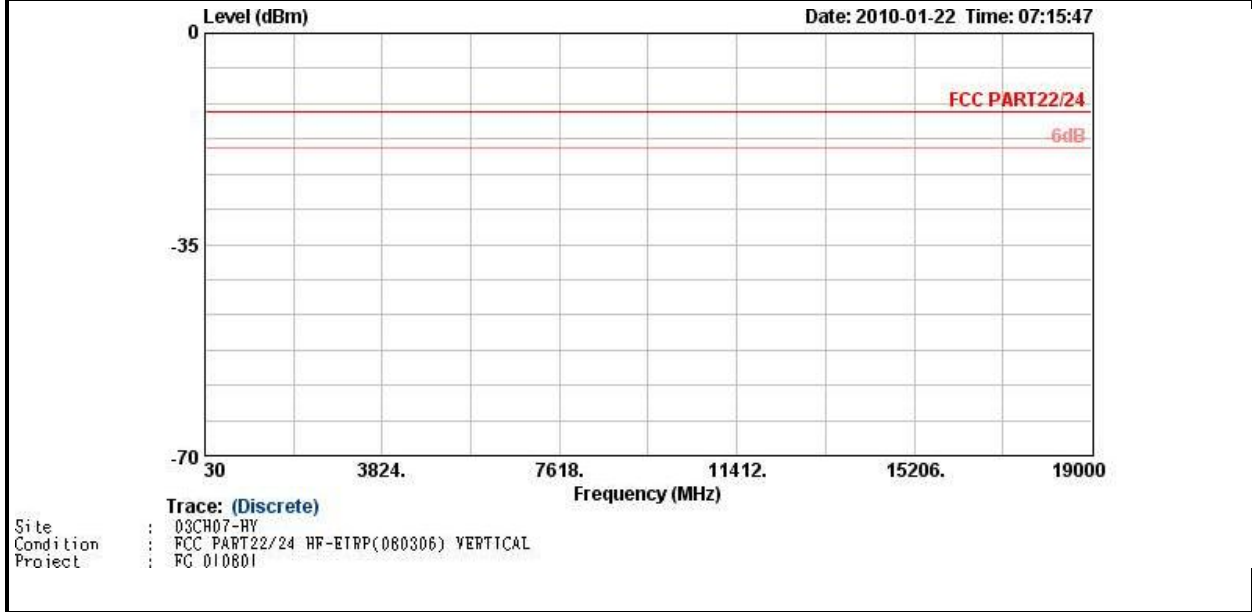





<b>Band :</b>	GSM1900	<b>Temperature :</b>	23~25°C
<b>Test Mode :</b>	GSM Link + 802.11a Tx CH165 + Qwerty Keypad	<b>Relative Humidity :</b>	50~54%
<b>Test Engineer :</b>	Cona Huang	<b>Polarization :</b>	Horizontal
<b>Remark :</b>	Spurious emissions within 30-1000MHz were found more than 20dB below limit line.		

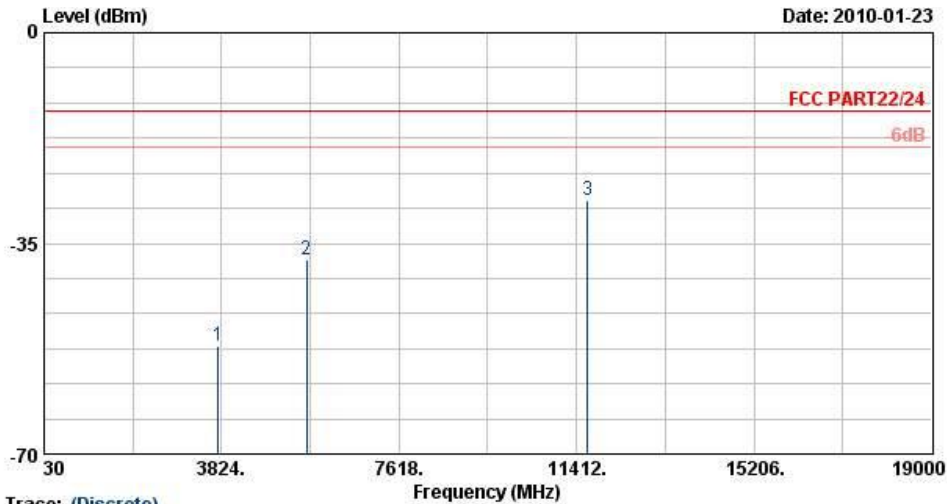

Trace: (Discrete)  
 Site : 03CH07-HY  
 Condition : FCC PART22/24 HF-ETRP(080306) HORIZONTAL  
 Project : FG 010801

Frequency (MHz)	EIRP (dBm)	Limit (dBm)	Over Limit (dB)	SPA Reading (dBm)	S.G. Power (dBm)	TX Cable loss (dB)	TX Antenna Gain (dBi)	Polarization (H/V)	Result
3760	-51.95	-13	-38.95	-62.68	-54.47	4.88	7.40	H	Pass
5636	-37.75	-13	-24.75	-57.53	-41.01	5.55	8.81	H	Pass
11650	-27.81	-13	-14.81	-57.05	-31.34	7.23	10.76	H	Pass



<b>Band :</b>	GSM1900	<b>Temperature :</b>	23~25°C
<b>Test Mode :</b>	GSM Link + 802.11a Tx CH165 + Qwerty Keypad	<b>Relative Humidity :</b>	50~54%
<b>Test Engineer :</b>	Cona Huang	<b>Polarization :</b>	Vertical
<b>Remark :</b>	Spurious emissions within 30-1000MHz were found more than 20dB below limit line.		

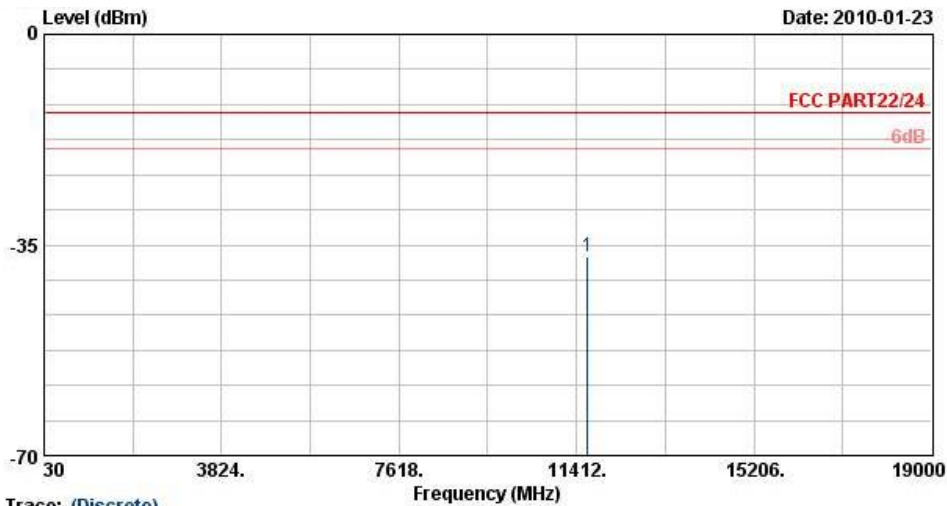

Trace: (Discrete)  
 Site : 03CH07-HY  
 Condition : FCC PART22/24 HF-ETRP(080306) VERTICAL  
 Project : FG 010801

Frequency ( MHz )	EIRP ( dBm )	Limit ( dBm )	Over Limit ( dB )	SPA Reading ( dBm )	S.G. Power ( dBm )	TX Cable loss ( dB )	TX Antenna Gain ( dBi )	Polarization ( H/V )	Result
11650	-36.96	-13	-23.96	-65.15	-41.09	7.23	11.36	V	Pass



<b>Band :</b>	WCDMA Band V	<b>Temperature :</b>	23~25°C
<b>Test Mode :</b>	RMC 12.2Kbps Link + Qwerty Keypad	<b>Relative Humidity :</b>	50~54%
<b>Test Engineer :</b>	Cona Huang	<b>Polarization :</b>	Horizontal
<b>Remark :</b>	Spurious emissions within 30-1000MHz were found more than 20dB below limit line, and within 1000MHz ~ 10th harmonic were not found any signals.		

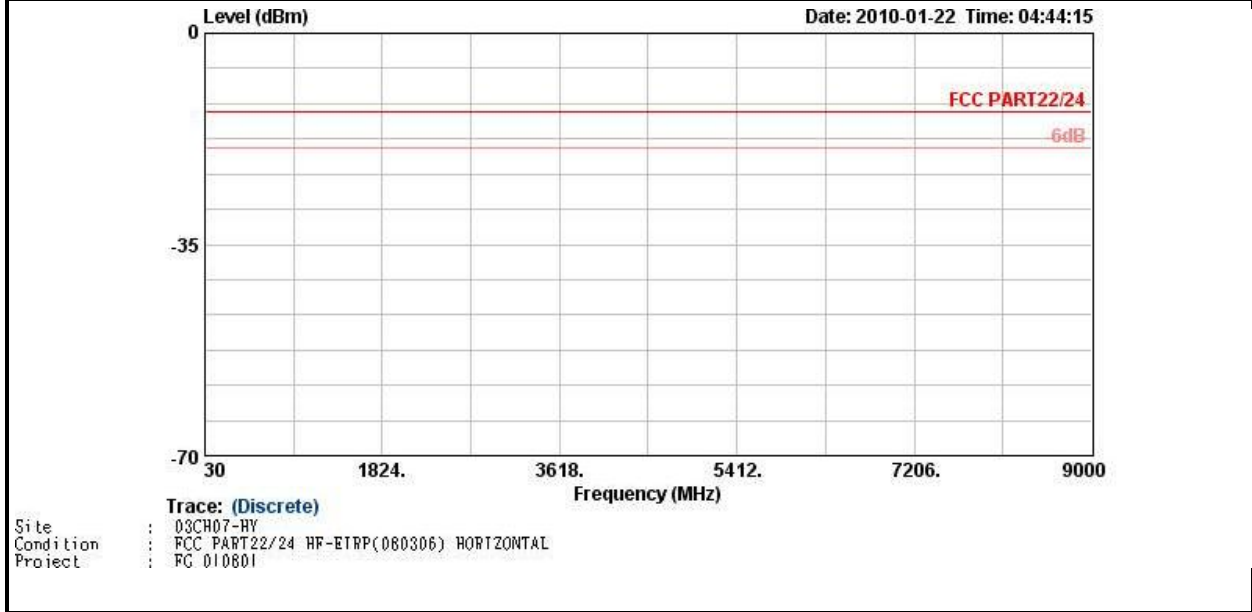



<b>Band :</b>	WCDMA Band V	<b>Temperature :</b>	23~25°C
<b>Test Mode :</b>	RMC 12.2Kbps Link + Qwerty Keypad	<b>Relative Humidity :</b>	50~54%
<b>Test Engineer :</b>	Cona Huang	<b>Polarization :</b>	Vertical
<b>Remark :</b>	Spurious emissions within 30-1000MHz were found more than 20dB below limit line, and within 1000MHz ~ 10th harmonic were not found any signals.		

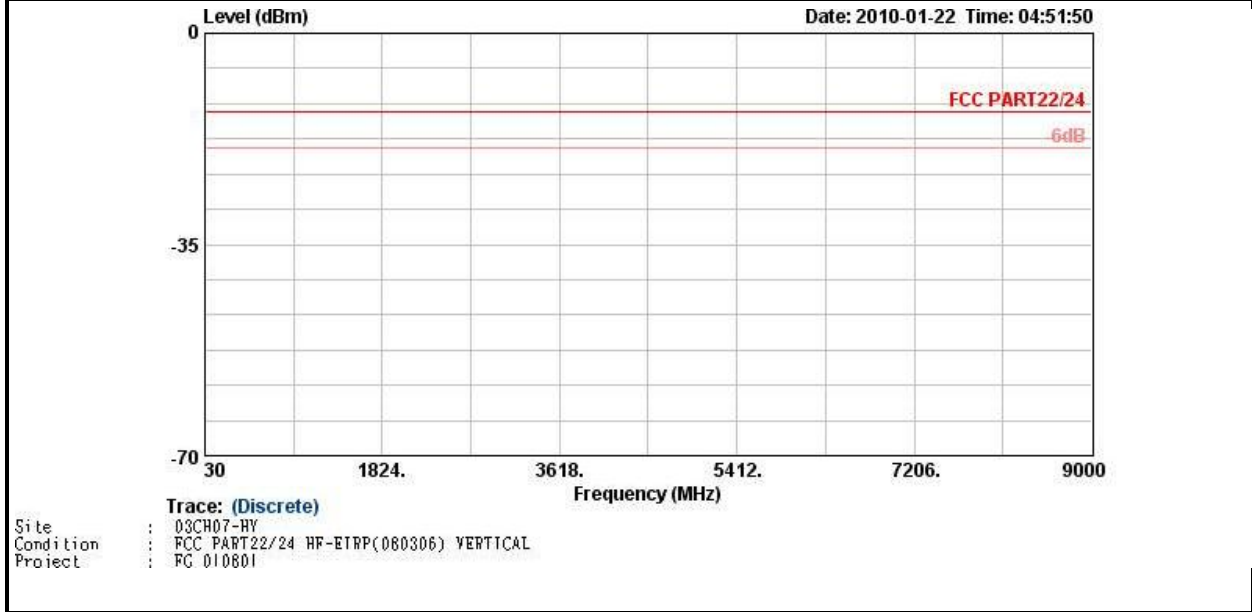



<b>Band :</b>	WCDMA Band V	<b>Temperature :</b>	23~25°C
<b>Test Mode :</b>	RMC 12.2Kbps Link + 802.11a Tx CH165 + Qwerty Keypad	<b>Relative Humidity :</b>	50~54%
<b>Test Engineer :</b>	Cona Huang	<b>Polarization :</b>	Horizontal
<b>Remark :</b>	Spurious emissions within 30-1000MHz were found more than 20dB below limit line, and within 1000MHz ~ 10th harmonic were not found any signals.		

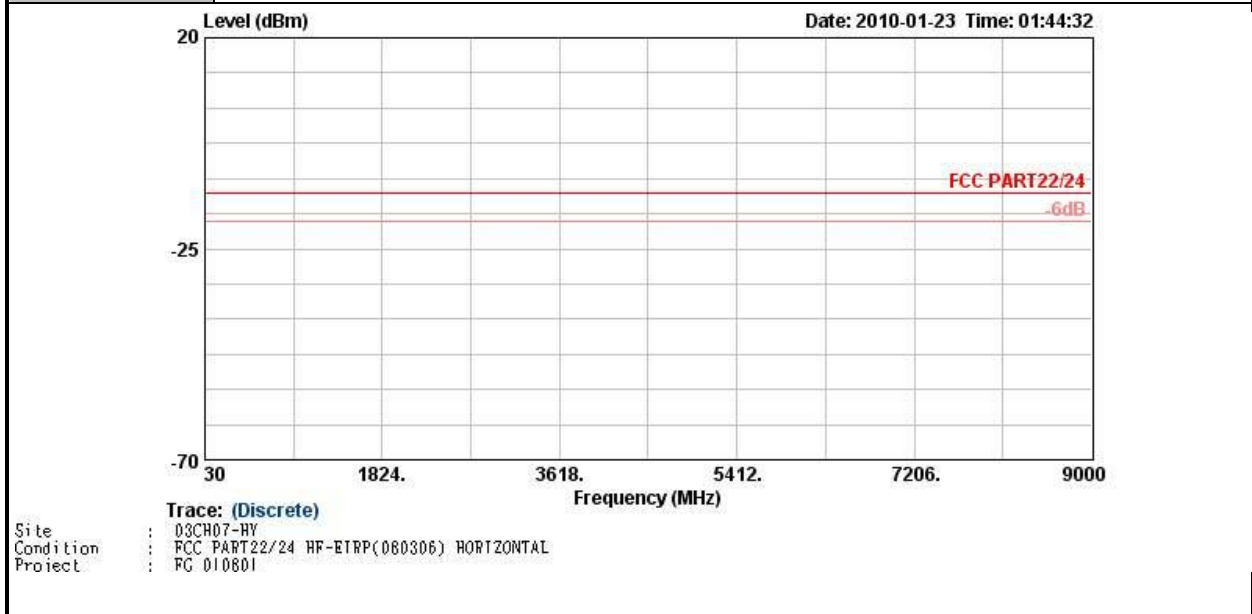



<b>Band :</b>	WCDMA Band V	<b>Temperature :</b>	23~25°C
<b>Test Mode :</b>	RMC 12.2Kbps Link + 802.11a Tx CH165 + Qwerty Keypad	<b>Relative Humidity :</b>	50~54%
<b>Test Engineer :</b>	Cona Huang	<b>Polarization :</b>	Vertical
<b>Remark :</b>	Spurious emissions within 30-1000MHz were found more than 20dB below limit line, and within 1000MHz ~ 10th harmonic were not found any signals.		

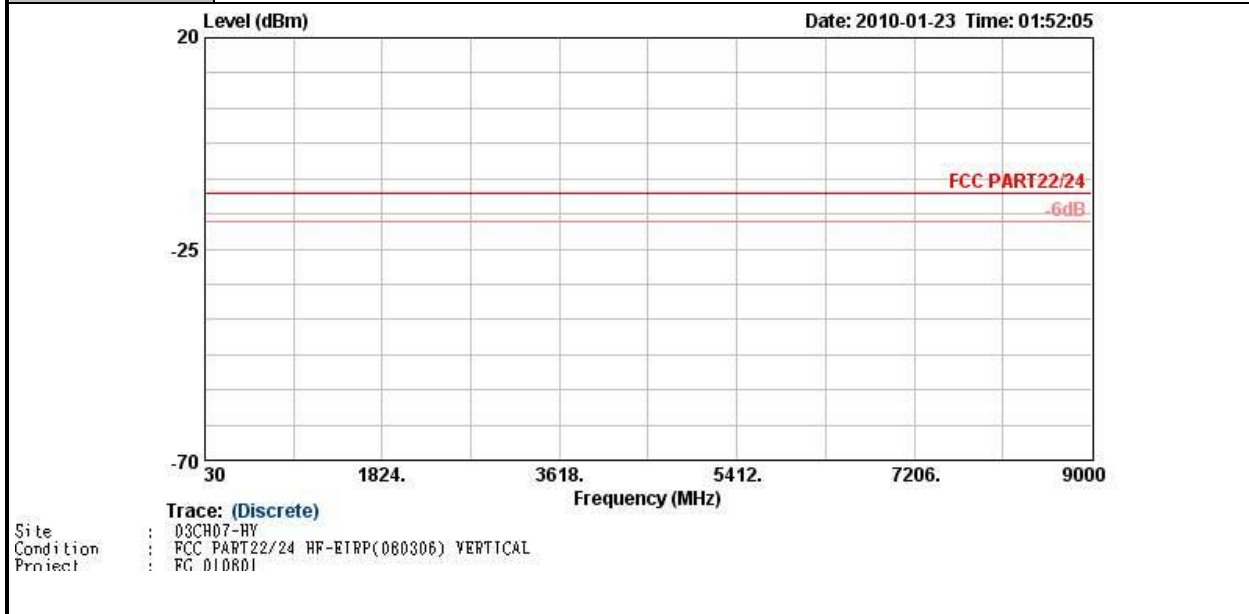



<b>Band :</b>	WCDMA Band II	<b>Temperature :</b>	23~25°C
<b>Test Mode :</b>	RMC 12.2Kbps Link + Qwerty Keypad	<b>Relative Humidity :</b>	50~54%
<b>Test Engineer :</b>	Cona Huang	<b>Polarization :</b>	Horizontal
<b>Remark :</b>	Spurious emissions within 30-1000MHz were found more than 20dB below limit line.		

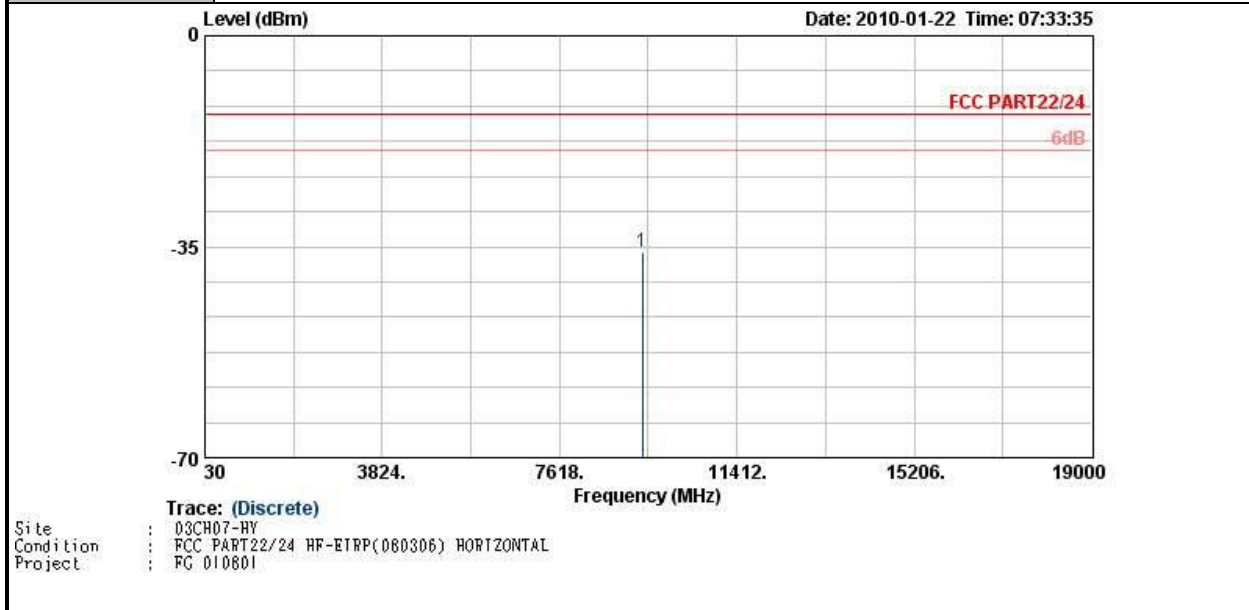

Frequency ( MHz )	EIRP ( dBm )	Limit ( dBm )	Over Limit ( dB )	SPA Reading ( dBm )	S.G. Power ( dBm )	TX Cable loss ( dB )	TX Antenna Gain ( dBi )	Polarization ( H/V )	Result
9396	-35.93	-13	-22.93	-59.85	-39.74	6.91	10.72	H	Pass



<b>Band :</b>	WCDMA Band II	<b>Temperature :</b>	23~25°C
<b>Test Mode :</b>	RMC 12.2Kbps Link + Qwerty Keypad	<b>Relative Humidity :</b>	50~54%
<b>Test Engineer :</b>	Cona Huang	<b>Polarization :</b>	Vertical
<b>Remark :</b>	Spurious emissions within 30-1000MHz were found more than 20dB below limit line.		

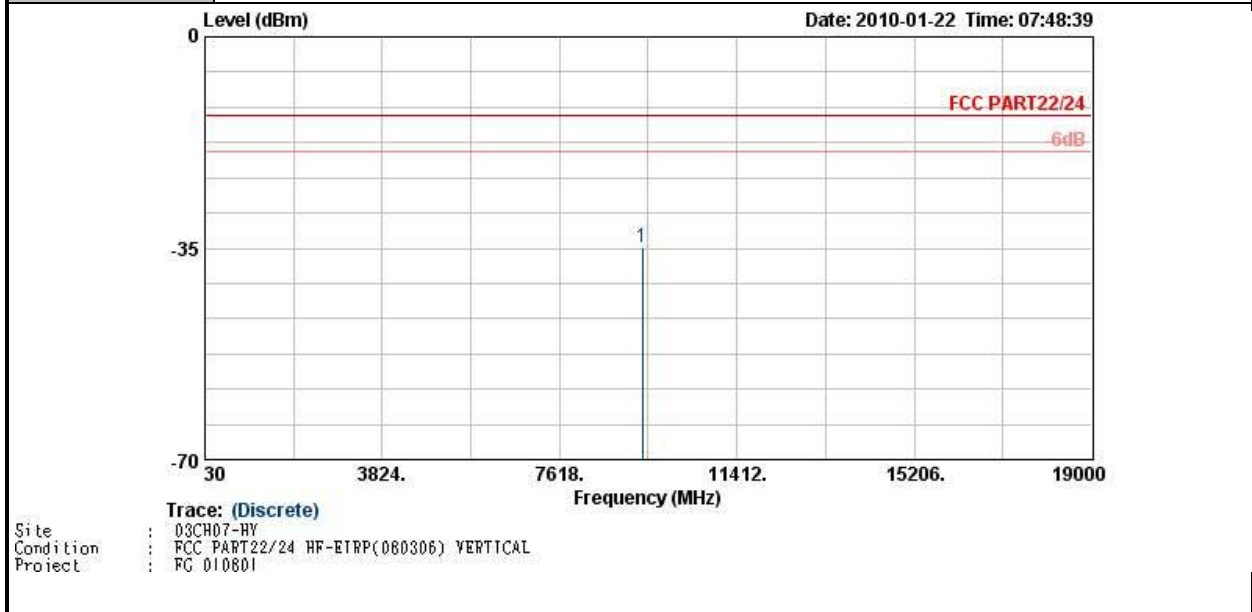

Frequency (MHz)	EIRP (dBm)	Limit (dBm)	Over Limit (dB)	SPA Reading (dBm)	S.G. Power (dBm)	TX Cable loss (dB)	TX Antenna Gain (dBi)	Polarization (H/V)	Result
9396	-34.95	-13	-21.95	-62.94	-39.56	6.91	11.52	V	Pass





<b>Band :</b>	WCDMA Band II	<b>Temperature :</b>	23~25°C
<b>Test Mode :</b>	RMC 12.2Kbps Link + 802.11a Tx CH165 + Qwerty Keypad	<b>Relative Humidity :</b>	50~54%
<b>Test Engineer :</b>	Cona Huang	<b>Polarization :</b>	Horizontal
<b>Remark :</b>	Spurious emissions within 30-1000MHz were found more than 20dB below limit line.		

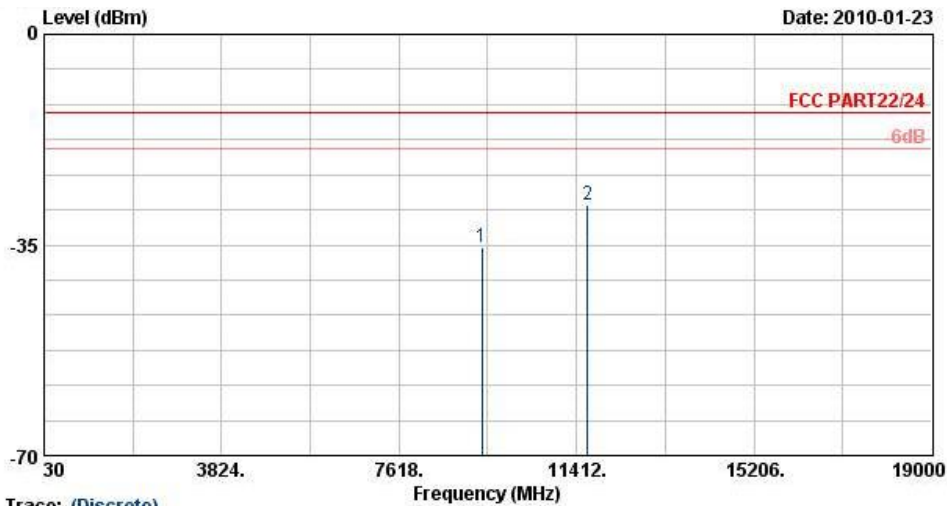

Trace: (Discrete)  
 Site : 03CH07-HY  
 Condition : FCC PART22/24 HF-ETRP(080306) HORIZONTAL  
 Project : FG\_010801

Frequency (MHz)	EIRP (dBm)	Limit (dBm)	Over Limit (dB)	SPA Reading (dBm)	S.G. Power (dBm)	TX Cable loss (dB)	TX Antenna Gain (dBi)	Polarization (H/V)	Result
9396	-35.29	-13	-22.29	-59.36	-39.1	6.91	10.72	H	Pass
11650	-28.46	-13	-15.46	-57.65	-31.99	7.23	10.76	H	Pass



<b>Band :</b>	WCDMA Band II	<b>Temperature :</b>	23~25°C
<b>Test Mode :</b>	RMC 12.2Kbps Link + 802.11a Tx CH165 + Qwerty Keypad	<b>Relative Humidity :</b>	50~54%
<b>Test Engineer :</b>	Cona Huang	<b>Polarization :</b>	Vertical
<b>Remark :</b>	Spurious emissions within 30-1000MHz were found more than 20dB below limit line.		

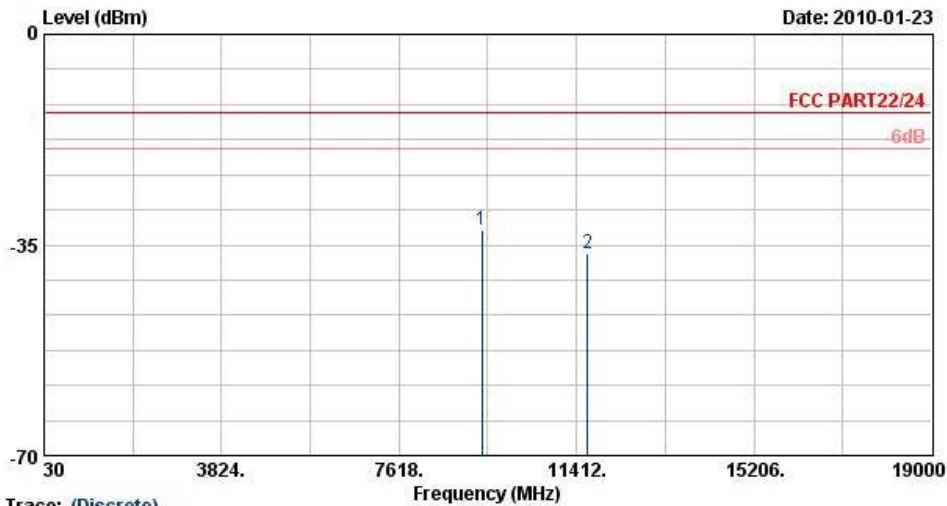

Trace: (Discrete)  
 Site : 03CH07-HY  
 Condition : FCC PART22/24 HF-ETRP(080306) VERTICAL  
 Project : FG\_010801

Frequency (MHz)	EIRP (dBm)	Limit (dBm)	Over Limit (dB)	SPA Reading (dBm)	S.G. Power (dBm)	TX Cable loss (dB)	TX Antenna Gain (dBi)	Polarization (H/V)	Result
9396	-32.44	-13	-19.44	-60.77	-37.05	6.91	11.52	V	Pass
11650	-36.38	-13	-23.38	-64.57	-40.51	7.23	11.36	V	Pass



<b>Band :</b>	CDMA2000 BC0	<b>Temperature :</b>	23~25°C
<b>Test Mode :</b>	1xRTT FCH_RC3+SO55 Link + Qwerty Keypad	<b>Relative Humidity :</b>	50~54%
<b>Test Engineer :</b>	Cona Huang	<b>Polarization :</b>	Horizontal
<b>Remark :</b>	Spurious emissions within 30-1000MHz were found more than 20dB below limit line.		

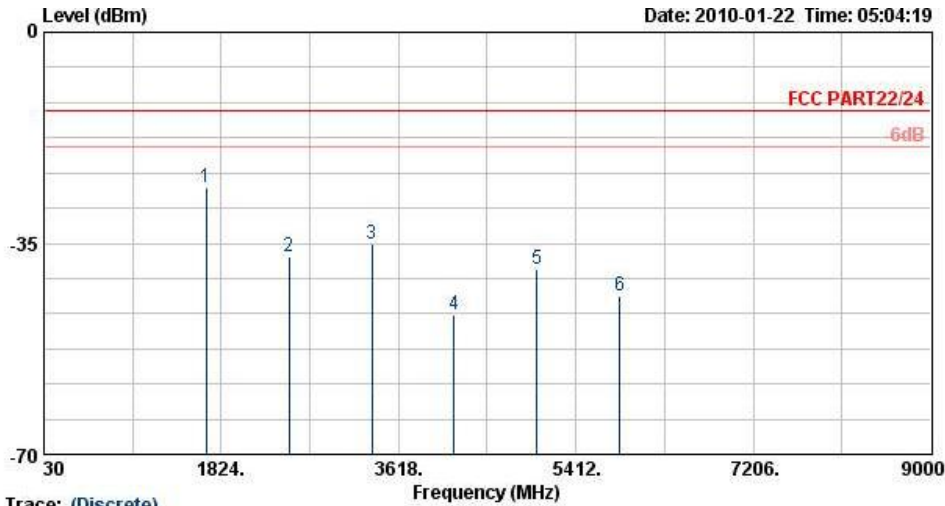

Trace: (Discrete)  
 Site : 03CH07-HY  
 Condition : FCC PART22/24 HF-ETRP(080306) HORIZONTAL  
 Project : FG D10R01

Frequency ( MHz )	EIRP ( dBm )	Limit ( dBm )	Over Limit ( dB )	SPA Reading ( dBm )	S.G. Power ( dBm )	TX Cable loss ( dB )	TX Antenna Gain ( dBi )	Polarization ( H/V )	Result
1669	-25.71	-13	-12.71	-35.2	-25.56	3.39	5.39	H	Pass
2509	-37.34	-13	-24.34	-45.7	-37.6	3.71	6.12	H	Pass
3346	-35.18	-13	-22.18	-45.9	-37.9	3.13	8.00	H	Pass
4175	-46.82	-13	-33.82	-59.92	-50.66	3.01	9.00	H	Pass
5015	-39.29	-13	-26.29	-55.34	-44.26	2.61	9.73	H	Pass
5855	-43.81	-13	-30.81	-60.44	-47.68	4.38	10.40	H	Pass



<b>Band :</b>	CDMA2000 BC0	<b>Temperature :</b>	23~25°C
<b>Test Mode :</b>	1xRTT FCH_RC3+SO55 Link + Qwerty Keypad	<b>Relative Humidity :</b>	50~54%
<b>Test Engineer :</b>	Cona Huang	<b>Polarization :</b>	Vertical
<b>Remark :</b>	Spurious emissions within 30-1000MHz were found more than 20dB below limit line.		



Trace: (Discrete)  
 Site : 03CH07-HY  
 Condition : FCC PART22/24 HF-ETRP(080306) VERTICAL  
 Project : FG 010801

Frequency ( MHz )	EIRP ( dBm )	Limit ( dBm )	Over Limit ( dB )	SPA Reading ( dBm )	S.G. Power ( dBm )	TX Cable loss ( dB )	TX Antenna Gain ( dBi )	Polarization ( H/V )	Result
1669	-31.36	-13	-18.36	-39.69	-31.21	3.39	5.39	V	Pass
2509	-36.96	-13	-23.96	-48.74	-37.22	3.71	6.12	V	Pass
3346	-38.06	-13	-25.06	-50.39	-40.78	3.13	8.00	V	Pass
4175	-41.13	-13	-28.13	-55.73	-44.97	3.01	9.00	V	Pass
5015	-38.57	-13	-25.57	-55.34	-43.54	2.61	9.73	V	Pass
5855	-43.14	-13	-30.14	-61.31	-47.01	4.38	10.40	V	Pass



<b>Band :</b>	CDMA2000 BC0	<b>Temperature :</b>	23~25°C
<b>Test Mode :</b>	1xRTT FCH_RC3+SO55 Link + Numeric Keypad	<b>Relative Humidity :</b>	50~54%
<b>Test Engineer :</b>	Cona Huang	<b>Polarization :</b>	Horizontal
<b>Remark :</b>	Spurious emissions within 30-1000MHz were found more than 20dB below limit line.		

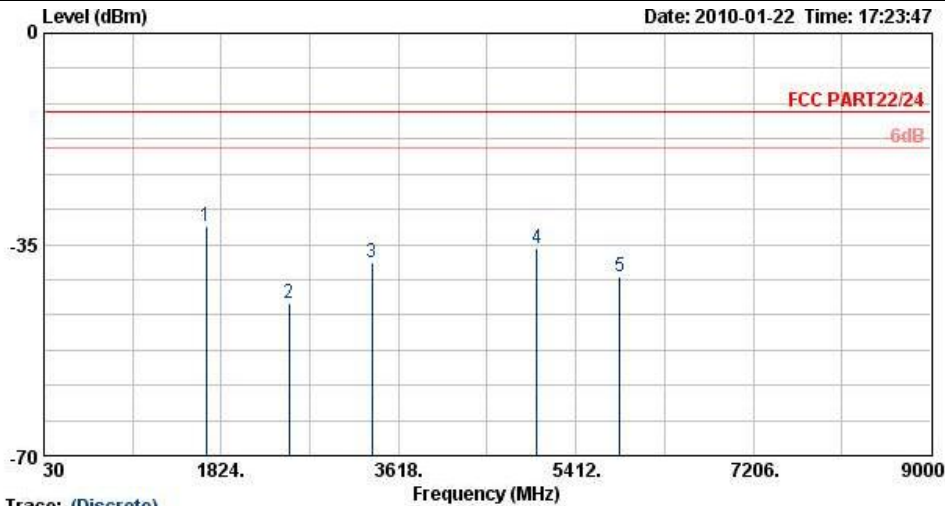

Trace: (Discrete)  
 Site : 03CH07-HY  
 Condition : FCC PART22/24 HF-ETRP(080306) HORIZONTAL  
 Project : FC 010801

Frequency (MHz)	EIRP (dBm)	Limit (dBm)	Over Limit (dB)	SPA Reading (dBm)	S.G. Power (dBm)	TX Cable loss (dB)	TX Antenna Gain (dBi)	Polarization (H/V)	Result
1669	-32.13	-13	-19.13	-41.4	-31.98	3.39	5.39	H	Pass
2509	-44.64	-13	-31.64	-52.68	-44.9	3.71	6.12	H	Pass
3345	-38.00	-13	-25.00	-47.74	-40.72	3.13	8.00	H	Pass
5015	-35.68	-13	-22.68	-51.78	-40.65	2.61	9.73	H	Pass
5854	-40.42	-13	-27.42	-57.97	-44.29	4.38	10.40	H	Pass



<b>Band :</b>	CDMA2000 BC0	<b>Temperature :</b>	23~25°C
<b>Test Mode :</b>	1xRTT FCH_RC3+SO55 Link + Numeric Keypad	<b>Relative Humidity :</b>	50~54%
<b>Test Engineer :</b>	Cona Huang	<b>Polarization :</b>	Vertical
<b>Remark :</b>	Spurious emissions within 30-1000MHz were found more than 20dB below limit line.		

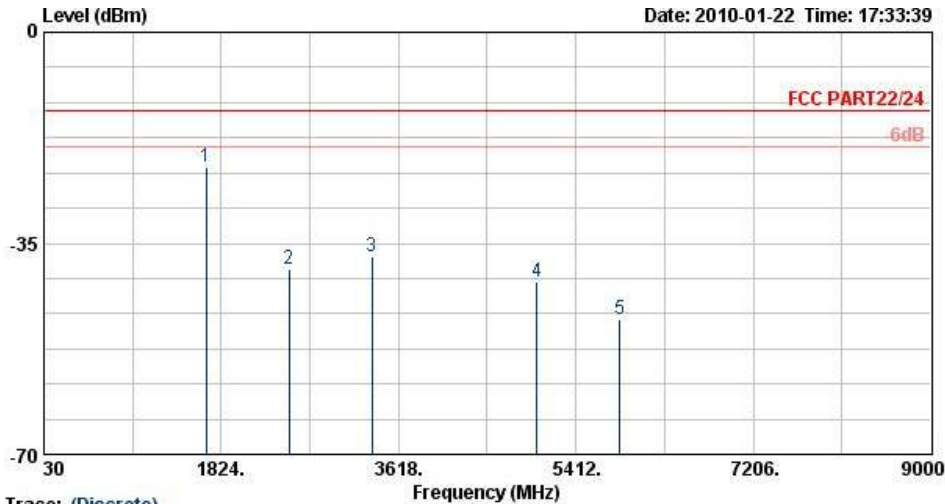

Trace: (Discrete)  
 Site : 03CH07-HY  
 Condition : FCC PART22/24 HF-ETRP(080306) VERTICAL  
 Project : FG D10R01

Frequency (MHz)	EIRP (dBm)	Limit (dBm)	Over Limit (dB)	SPA Reading (dBm)	S.G. Power (dBm)	TX Cable loss (dB)	TX Antenna Gain (dBi)	Polarization (H/V)	Result
1669	-22.41	-13	-9.41	-35.58	-22.26	3.39	5.39	V	Pass
2509	-39.42	-13	-26.42	-50.85	-39.68	3.71	6.12	V	Pass
3345	-37.18	-13	-24.18	-50.23	-39.9	3.13	8.00	V	Pass
5015	-41.32	-13	-28.32	-57.45	-46.29	2.61	9.73	V	Pass
5854	-47.51	-13	-34.51	-62.03	-51.38	4.38	10.40	V	Pass



<b>Band :</b>	CDMA2000 BC0	<b>Temperature :</b>	23~25°C
<b>Test Mode :</b>	1xRTT FCH_RC3+SO55 Link + 802.11a Tx CH165 + Qwerty Keypad	<b>Relative Humidity :</b>	50~54%
<b>Test Engineer :</b>	Cona Huang	<b>Polarization :</b>	Horizontal
<b>Remark :</b>	Spurious emissions within 30-1000MHz were found more than 20dB below limit line.		

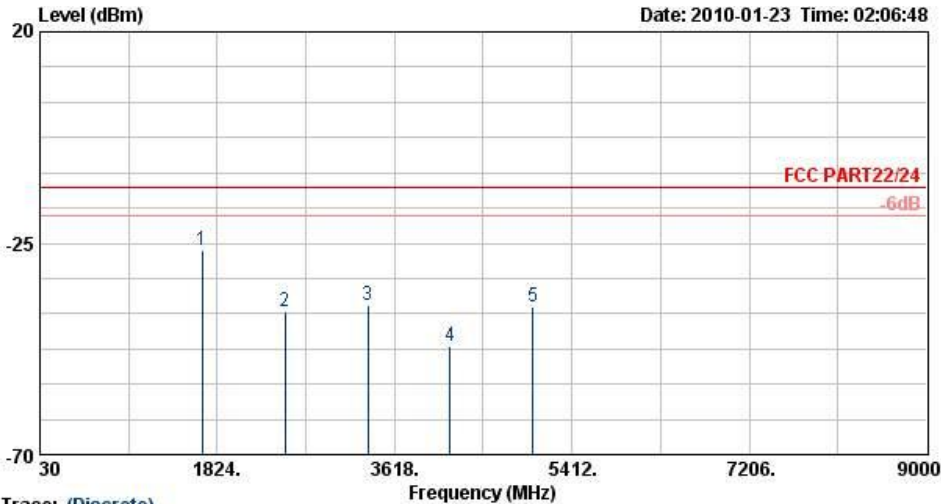

Trace: (Discrete)  
 Site : 03CH07-HY  
 Condition : FCC PART22/24 HF-ETRP(080306) HORIZONTAL  
 Project : FG 010801

Frequency (MHz)	EIRP (dBm)	Limit (dBm)	Over Limit (dB)	SPA Reading (dBm)	S.G. Power (dBm)	TX Cable loss (dB)	TX Antenna Gain (dBi)	Polarization (H/V)	Result
1669	-26.34	-13	-13.34	-35.47	-26.19	3.39	5.39	H	Pass
2509	-39.40	-13	-26.40	-47.64	-39.66	3.71	6.12	H	Pass
3346	-38.32	-13	-25.32	-48.06	-41.04	3.13	8.00	H	Pass
4175	-47.05	-13	-34.05	-60.15	-50.89	3.01	9.00	H	Pass
5015	-38.65	-13	-25.65	-54.59	-43.62	2.61	9.73	H	Pass



<b>Band :</b>	CDMA2000 BC0	<b>Temperature :</b>	23~25°C
<b>Test Mode :</b>	1xRTT FCH_RC3+SO55 Link + 802.11a Tx CH165 + Qwerty Keypad	<b>Relative Humidity :</b>	50~54%
<b>Test Engineer :</b>	Cona Huang	<b>Polarization :</b>	Vertical
<b>Remark :</b>	Spurious emissions within 30-1000MHz were found more than 20dB below limit line.		

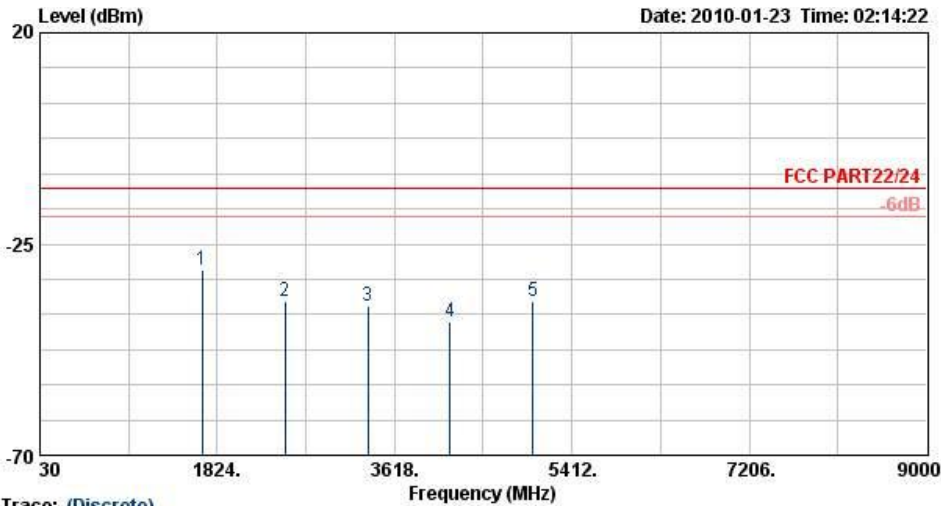

Trace: (Discrete)  
 Site : 03CH07-HY  
 Condition : FCC PART22/24 HF-ETRP(080306) VERTICAL  
 Project : FG 010801

Frequency (MHz)	EIRP (dBm)	Limit (dBm)	Over Limit (dB)	SPA Reading (dBm)	S.G. Power (dBm)	TX Cable loss (dB)	TX Antenna Gain (dBi)	Polarization (H/V)	Result
1669	-30.49	-13	-17.49	-39.8	-30.34	3.39	5.39	V	Pass
2509	-37.33	-13	-24.33	-49.06	-37.59	3.71	6.12	V	Pass
3346	-38.07	-13	-25.07	-50.4	-40.79	3.13	8.00	V	Pass
4175	-41.43	-13	-28.43	-56.05	-45.27	3.01	9.00	V	Pass
5015	-37.24	-13	-24.24	-53.94	-42.21	2.61	9.73	V	Pass





<b>Band :</b>	CDMA2000 BC0	<b>Temperature :</b>	23~25°C
<b>Test Mode :</b>	1xRTT FCH_RC3+SO55 Link + 802.11a Tx CH165 + Numeric Keypad	<b>Relative Humidity :</b>	50~54%
<b>Test Engineer :</b>	Cona Huang	<b>Polarization :</b>	Horizontal
<b>Remark :</b>	Spurious emissions within 30-1000MHz were found more than 20dB below limit line.		

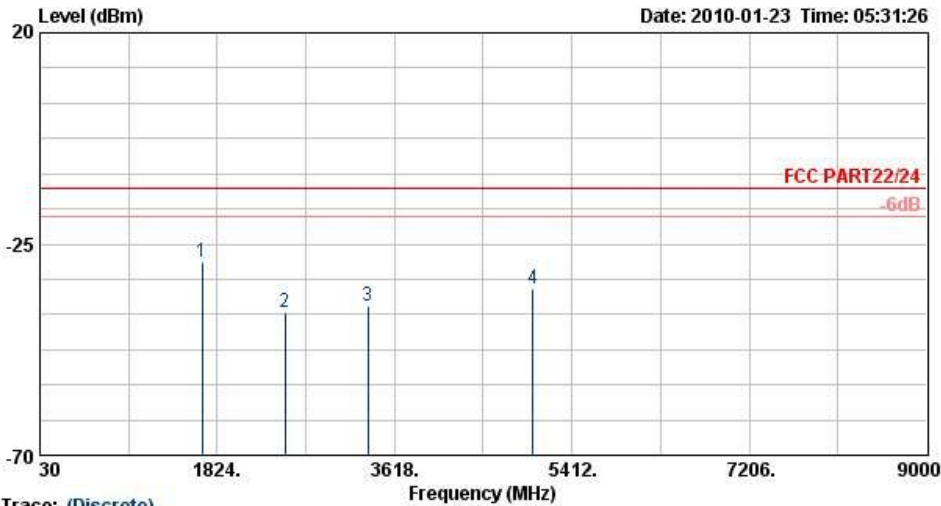

Trace: (Discrete)  
 Site : 03CH07-HY  
 Condition : FCC PART22/24 HF-ETRP(080306) HORIZONTAL  
 Project : FG 010801

Frequency (MHz)	EIRP (dBm)	Limit (dBm)	Over Limit (dB)	SPA Reading (dBm)	S.G. Power (dBm)	TX Cable loss (dB)	TX Antenna Gain (dBi)	Polarization (H/V)	Result
1669	-28.75	-13	-15.75	-38.41	-28.6	3.39	5.39	H	Pass
2509	-39.54	-13	-26.54	-47.78	-39.8	3.71	6.12	H	Pass
3346	-38.27	-13	-25.27	-48.1	-40.99	3.13	8.00	H	Pass
5015	-34.44	-13	-21.44	-50.63	-39.41	2.61	9.73	H	Pass



<b>Band :</b>	CDMA2000 BC0	<b>Temperature :</b>	23~25°C
<b>Test Mode :</b>	1xRTT FCH_RC3+SO55 Link + 802.11a Tx CH165 + Numeric Keypad	<b>Relative Humidity :</b>	50~54%
<b>Test Engineer :</b>	Cona Huang	<b>Polarization :</b>	Vertical
<b>Remark :</b>	Spurious emissions within 30-1000MHz were found more than 20dB below limit line.		

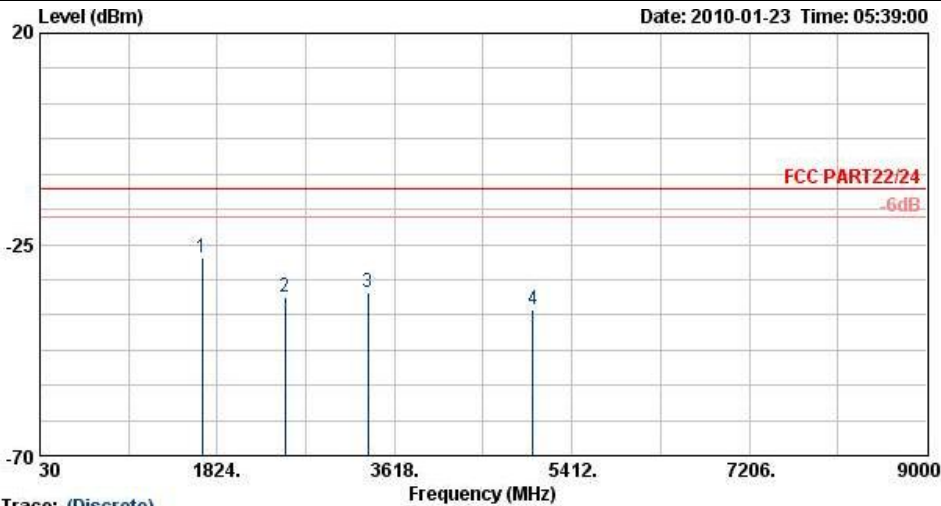

Trace: (Discrete)  
 Site : 03CH07-HY  
 Condition : FCC PART22/24 HF-ETRP(080306) VERTICAL  
 Project : FC 010801

Frequency ( MHz )	EIRP ( dBm )	Limit ( dBm )	Over Limit ( dB )	SPA Reading ( dBm )	S.G. Power ( dBm )	TX Cable loss ( dB )	TX Antenna Gain ( dBi )	Polarization ( H/V )	Result
1669	-27.92	-13	-14.92	-37.39	-27.77	3.39	5.39	V	Pass
2509	-36.06	-13	-23.06	-47.87	-36.32	3.71	6.12	V	Pass
3346	-35.29	-13	-22.29	-48.04	-38.01	3.13	8.00	V	Pass
5015	-38.95	-13	-25.95	-55.72	-43.92	2.61	9.73	V	Pass



<b>Band :</b>	CDMA2000 BC1	<b>Temperature :</b>	23~25°C
<b>Test Mode :</b>	1xRTT FCH_RC3+SO55 Link + Qwerty Keypad	<b>Relative Humidity :</b>	50~54%
<b>Test Engineer :</b>	Cona Huang	<b>Polarization :</b>	Horizontal
<b>Remark :</b>	Spurious emissions within 30-1000MHz were found more than 20dB below limit line.		

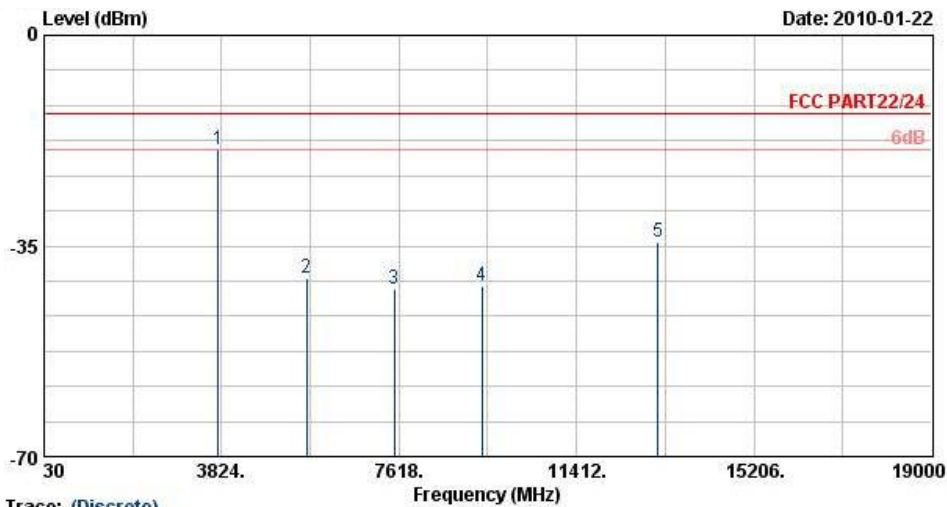

Trace: (Discrete)  
 Site : 03CH07-HY  
 Condition : FCC PART22/24 HF-ETRP(080306) HORIZONTAL  
 Project : FG 010801

Frequency (MHz)	EIRP (dBm)	Limit (dBm)	Over Limit (dB)	SPA Reading (dBm)	S.G. Power (dBm)	TX Cable loss (dB)	TX Antenna Gain (dBi)	Polarization (H/V)	Result
3760	-19.11	-13	-6.11	-30.95	-24.99	1.52	7.40	H	Pass
5636	-40.38	-13	-27.38	-59.6	-43.64	5.55	8.81	H	Pass
7520	-42.18	-13	-29.18	-63.36	-45.25	6.64	9.71	H	Pass
9396	-41.67	-13	-28.67	-63.6	-45.48	6.91	10.72	H	Pass
13156	-34.26	-13	-21.26	-66.69	-36.49	8.8	11.03	H	Pass



<b>Band :</b>	CDMA2000 BC1	<b>Temperature :</b>	23~25°C
<b>Test Mode :</b>	1xRTT FCH_RC3+SO55 Link + Qwerty Keypad	<b>Relative Humidity :</b>	50~54%
<b>Test Engineer :</b>	Cona Huang	<b>Polarization :</b>	Vertical
<b>Remark :</b>	Spurious emissions within 30-1000MHz were found more than 20dB below limit line.		

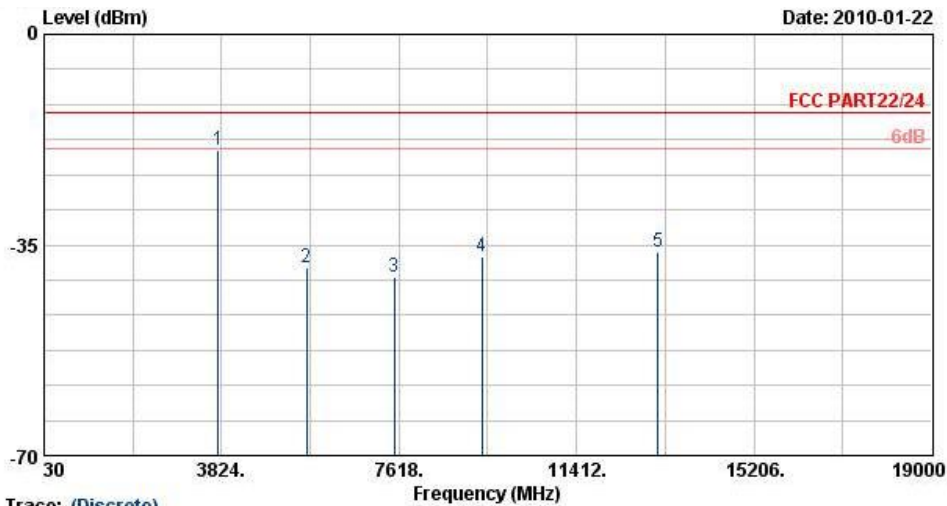

Trace: (Discrete)  
 Site : 03CH07-HY  
 Condition : FCC PART22/24 HF-ETRP(080306) VERTICAL  
 Project : FG\_010801

Frequency (MHz)	EIRP (dBm)	Limit (dBm)	Over Limit (dB)	SPA Reading (dBm)	S.G. Power (dBm)	TX Cable loss (dB)	TX Antenna Gain (dBi)	Polarization (H/V)	Result
3760	-19.30	-13	-6.30	-33.15	-25.69	1.52	7.91	V	Pass
5636	-38.77	-13	-25.77	-59.39	-42.99	5.55	9.77	V	Pass
7520	-40.29	-13	-27.29	-61.74	-44.46	6.64	10.81	V	Pass
9396	-36.97	-13	-23.97	-63.93	-41.58	6.91	11.52	V	Pass
13156	-36.09	-13	-23.09	-66.54	-39.45	8.8	12.16	V	Pass



<b>Band :</b>	CDMA2000 BC1	<b>Temperature :</b>	23~25°C
<b>Test Mode :</b>	1xRTT FCH_RC3+SO55 Link + Numeric Keypad	<b>Relative Humidity :</b>	50~54%
<b>Test Engineer :</b>	Cona Huang	<b>Polarization :</b>	Horizontal
<b>Remark :</b>	Spurious emissions within 30-1000MHz were found more than 20dB below limit line.		

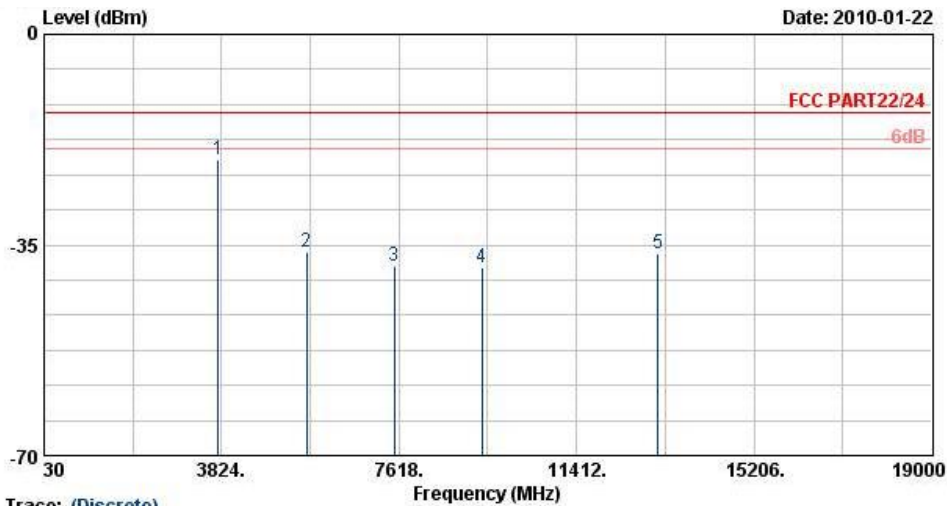

Trace: (Discrete)  
 Site : 03CH07-HY  
 Condition : FCC PART22/24 HF-ETRP(080306) HORIZONTAL  
 Project : FG\_010801

Frequency (MHz)	EIRP (dBm)	Limit (dBm)	Over Limit (dB)	SPA Reading (dBm)	S.G. Power (dBm)	TX Cable loss (dB)	TX Antenna Gain (dBi)	Polarization (H/V)	Result
3760	-20.94	-13	-7.94	-33.12	-26.82	1.52	7.40	H	Pass
5636	-36.11	-13	-23.11	-56.12	-39.37	5.55	8.81	H	Pass
7520	-38.46	-13	-25.46	-60.35	-41.53	6.64	9.71	H	Pass
9396	-38.68	-13	-25.68	-61.72	-42.49	6.91	10.72	H	Pass
13156	-36.52	-13	-23.52	-66.87	-38.75	8.8	11.03	H	Pass



<b>Band :</b>	CDMA2000 BC1	<b>Temperature :</b>	23~25°C
<b>Test Mode :</b>	1xRTT FCH_RC3+SO55 Link + Numeric Keypad	<b>Relative Humidity :</b>	50~54%
<b>Test Engineer :</b>	Cona Huang	<b>Polarization :</b>	Vertical
<b>Remark :</b>	Spurious emissions within 30-1000MHz were found more than 20dB below limit line.		

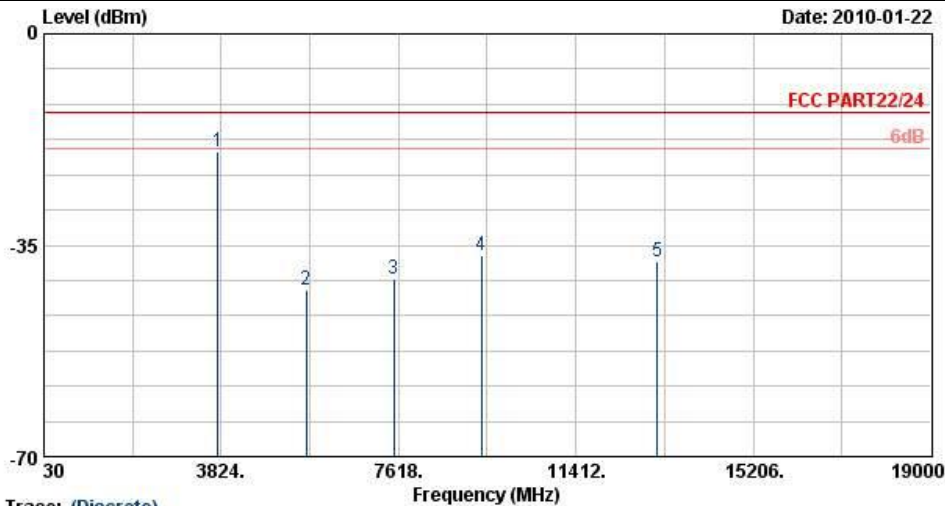

Trace: (Discrete)  
 Site : 03CH07-HY  
 Condition : FCC PART22/24 HF-ETRP(080306) VERTICAL  
 Project : FG 010801

Frequency (MHz)	EIRP (dBm)	Limit (dBm)	Over Limit (dB)	SPA Reading (dBm)	S.G. Power (dBm)	TX Cable loss (dB)	TX Antenna Gain (dBi)	Polarization (H/V)	Result
3760	-19.58	-13	-6.58	-32.57	-25.97	1.52	7.91	V	Pass
5636	-42.49	-13	-29.49	-62.36	-46.71	5.55	9.77	V	Pass
7520	-40.69	-13	-27.69	-62.6	-44.86	6.64	10.81	V	Pass
9396	-36.76	-13	-23.76	-63.72	-41.37	6.91	11.52	V	Pass
13156	-37.86	-13	-24.86	-67.59	-41.22	8.8	12.16	V	Pass



<b>Band :</b>	CDMA2000 BC1	<b>Temperature :</b>	23~25°C
<b>Test Mode :</b>	1xRTT FCH_RC3+SO55 Link + 802.11a Tx CH165 + Qwerty Keypad	<b>Relative Humidity :</b>	50~54%
<b>Test Engineer :</b>	Cona Huang	<b>Polarization :</b>	Horizontal
<b>Remark :</b>	Spurious emissions within 30-1000MHz were found more than 20dB below limit line.		

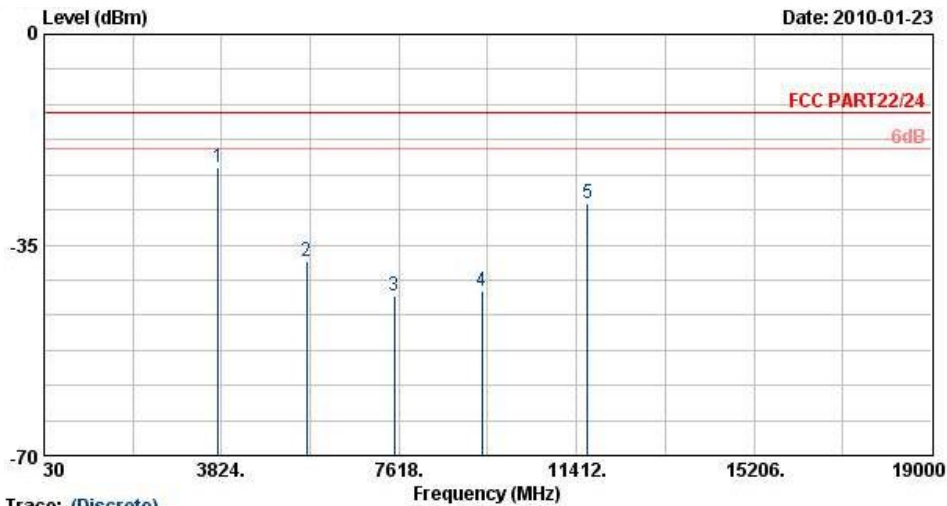

Trace: (Discrete)  
 Site : 03CH07-HY  
 Condition : FCC PART22/24 HF-ETRP(080306) HORIZONTAL  
 Project : FG\_010801

Frequency (MHz)	EIRP (dBm)	Limit (dBm)	Over Limit (dB)	SPA Reading (dBm)	S.G. Power (dBm)	TX Cable loss (dB)	TX Antenna Gain (dBi)	Polarization (H/V)	Result
3760	-22.18	-13	-9.18	-34.02	-28.06	1.52	7.40	H	Pass
5636	-37.66	-13	-24.66	-57.44	-40.92	5.55	8.81	H	Pass
7520	-43.48	-13	-30.48	-64.08	-46.55	6.64	9.71	H	Pass
9396	-42.59	-13	-29.59	-64.08	-46.4	6.91	10.72	H	Pass
11650	-28.14	-13	-15.14	-57.33	-31.67	7.23	10.76	H	Pass



<b>Band :</b>	CDMA2000 BC1	<b>Temperature :</b>	23~25°C
<b>Test Mode :</b>	1xRTT FCH_RC3+SO55 Link + 802.11a Tx CH165 + Qwerty Keypad	<b>Relative Humidity :</b>	50~54%
<b>Test Engineer :</b>	Cona Huang	<b>Polarization :</b>	Vertical
<b>Remark :</b>	Spurious emissions within 30-1000MHz were found more than 20dB below limit line.		

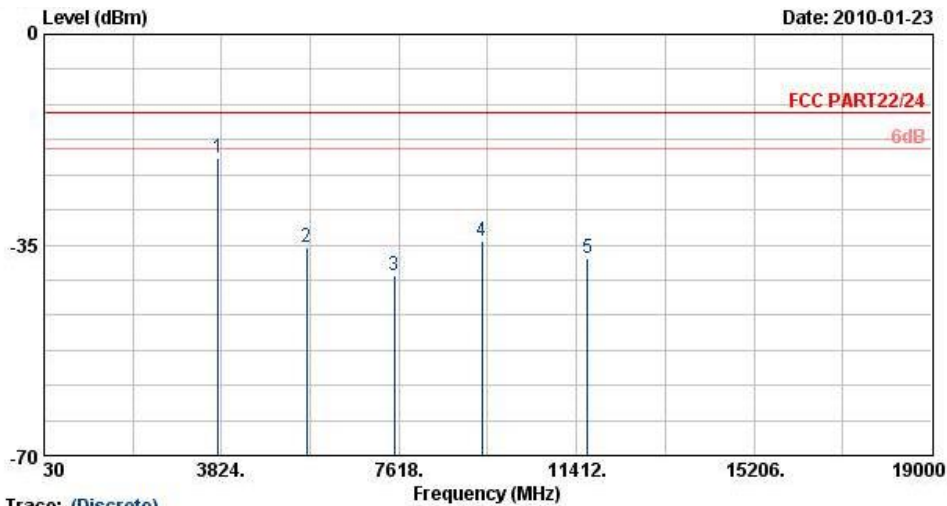

Trace: (Discrete)  
 Site : 03CH07-HY  
 Condition : FCC PART22/24 HF-ETRP(080306) VERTICAL  
 Project : FG\_010801

Frequency (MHz)	EIRP (dBm)	Limit (dBm)	Over Limit (dB)	SPA Reading (dBm)	S.G. Power (dBm)	TX Cable loss (dB)	TX Antenna Gain (dBi)	Polarization (H/V)	Result
3760	-20.45	-13	-7.45	-34.3	-26.84	1.52	7.91	V	Pass
5636	-35.27	-13	-22.27	-56.28	-39.49	5.55	9.77	V	Pass
7520	-40.02	-13	-27.02	-61.49	-44.19	6.64	10.81	V	Pass
9396	-34.28	-13	-21.28	-62.41	-38.89	6.91	11.52	V	Pass
11650	-37.32	-13	-24.32	-65.51	-41.45	7.23	11.36	V	Pass





<b>Band :</b>	CDMA2000 BC1	<b>Temperature :</b>	23~25°C
<b>Test Mode :</b>	1xRTT FCH_RC3+SO55 Link + 802.11a Tx CH165 + Numeric Keypad	<b>Relative Humidity :</b>	50~54%
<b>Test Engineer :</b>	Cona Huang	<b>Polarization :</b>	Horizontal
<b>Remark :</b>	Spurious emissions within 30-1000MHz were found more than 20dB below limit line.		

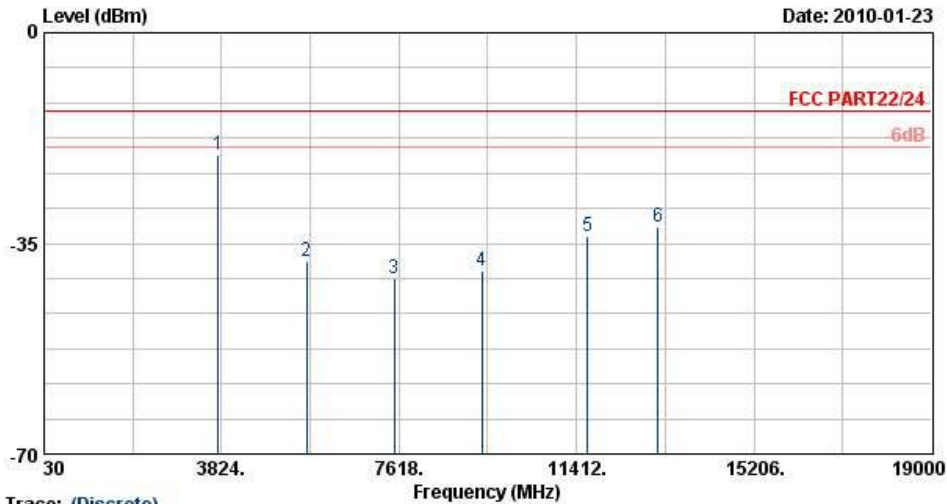

Trace: (Discrete)  
 Site : 03CH07-HY  
 Condition : FCC PART22/24 HF-ETRP(080306) HORIZONTAL  
 Project : FG 010801

Frequency ( MHz )	EIRP ( dBm )	Limit ( dBm )	Over Limit ( dB )	SPA Reading ( dBm )	S.G. Power ( dBm )	TX Cable loss ( dB )	TX Antenna Gain ( dBi )	Polarization ( H/V )	Result
3760	-20.18	-13	-7.18	-32.02	-26.06	1.52	7.40	H	Pass
5636	-37.87	-13	-24.87	-57.65	-41.13	5.55	8.81	H	Pass
7520	-40.75	-13	-27.75	-62.65	-43.82	6.64	9.71	H	Pass
9396	-39.59	-13	-26.59	-62.21	-43.4	6.91	10.72	H	Pass
11650	-33.76	-13	-20.76	-62.95	-37.29	7.23	10.76	H	Pass
13156	-32.35	-13	-19.35	-64.78	-34.58	8.8	11.03	H	Pass



<b>Band :</b>	CDMA2000 BC1	<b>Temperature :</b>	23~25°C
<b>Test Mode :</b>	1xRTT FCH_RC3+SO55 Link + 802.11a Tx CH165 + Numeric Keypad	<b>Relative Humidity :</b>	50~54%
<b>Test Engineer :</b>	Cona Huang	<b>Polarization :</b>	Vertical
<b>Remark :</b>	Spurious emissions within 30-1000MHz were found more than 20dB below limit line.		

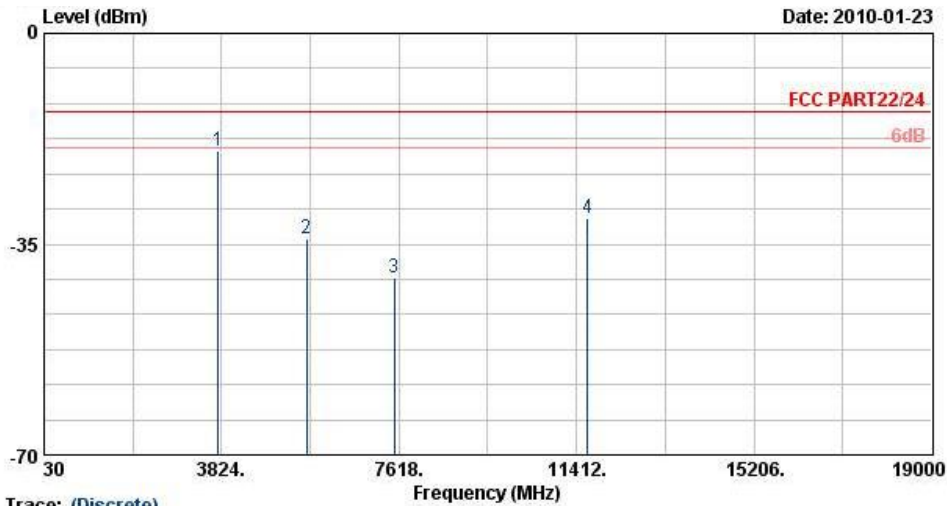

Trace: (Discrete)  
 Site : 03CH07-HY  
 Condition : FCC PART22/24 HF-ETRP(080306) VERTICAL  
 Project : FG 010801

Frequency (MHz)	EIRP (dBm)	Limit (dBm)	Over Limit (dB)	SPA Reading (dBm)	S.G. Power (dBm)	TX Cable loss (dB)	TX Antenna Gain (dBi)	Polarization (H/V)	Result
3760	-19.49	-13	-6.49	-32.61	-25.88	1.52	7.91	V	Pass
5636	-34.17	-13	-21.17	-55.49	-38.39	5.55	9.77	V	Pass
7520	-40.59	-13	-27.59	-62.36	-44.76	6.64	10.81	V	Pass
11650	-30.83	-13	-17.83	-59.05	-34.96	7.23	11.36	V	Pass

## 3.7 Frequency Stability Measurement

### 3.7.1 Description of Frequency Stability Measurement

The frequency stability shall be measured by variation of ambient temperature and variation of primary supply voltage to ensure that the fundamental emission stays within the authorized frequency block. The frequency stability of the transmitter shall be maintained within  $\pm 0.00025\%$  ( $\pm 2.5\text{ppm}$ ) of the center frequency.

### 3.7.2 Measuring Instruments

See list of measuring instruments of this test report.

### 3.7.3 Test Procedures for Temperature Variation

1. The EUT was set up in the thermal chamber and connected with the base station.
2. With power OFF, the temperature was decreased to  $-30^{\circ}\text{C}$  and the EUT was stabilized for three hours. Power was applied and the maximum change in frequency was recorded within one minute.
3. With power OFF, the temperature was raised in  $10^{\circ}\text{C}$  step up to  $50^{\circ}\text{C}$ . The EUT was stabilized at each step for at least half an hour. Power was applied and the maximum frequency change was recorded within one minute.
4. If the EUT can not be turned on at  $-30^{\circ}\text{C}$ , the testing lowest temperature will be raised in  $10^{\circ}\text{C}$  step until the EUT can be turned on.

### 3.7.4 Test Procedures for Voltage Variation

1. The EUT was placed in a temperature chamber at  $25\pm 5^{\circ}\text{C}$  and connected with the base station.
2. The power supply voltage to the EUT was varied from BEP to 115% of the nominal value measured at the input to the EUT.
3. The variation in frequency was measured for the worst case.

### 3.7.5 Test Setup

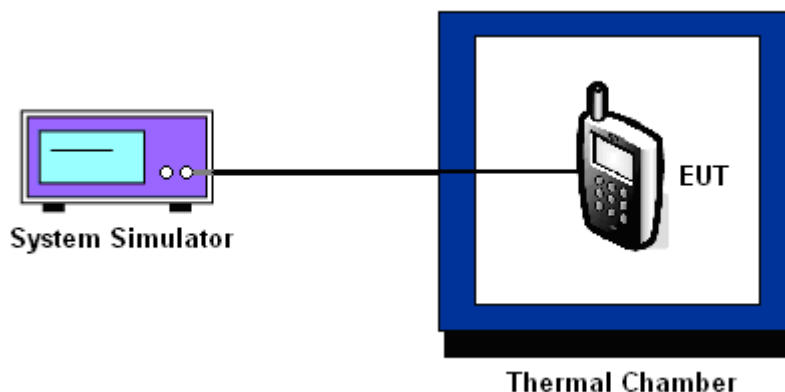



3.7.6 Test Result of Temperature Variation

Band :	GSM 850	Channel :	189
Limit (ppm) :	2.5		

Temperature (°C)	GSM		EDGE 8		Result
	Freq. Dev. (Hz)	Deviation (ppm)	Freq. Dev. (Hz)	Deviation (ppm)	
-30	-43.14	-0.05	42.09	0.05	PASS
-20	-34.11	-0.04	-34.28	-0.04	
-10	-40.13	-0.05	-41.04	-0.05	
0	-22.22	-0.03	-23.71	-0.03	
10	-43.19	-0.05	24.97	0.03	
20	31.17	0.04	22.78	0.03	
30	39.14	0.05	-13.13	-0.02	
40	41.97	0.05	-22.71	-0.03	
50	-38.18	-0.04	-43.79	-0.05	

Band :	GSM 1900	Channel :	661
Limit (ppm) :	2.5		

Temperature (°C)	GSM		EDGE 8		Result
	Freq. Dev. (Hz)	Deviation (ppm)	Freq. Dev. (Hz)	Deviation (ppm)	
-30	-34.17	-0.02	40.57	0.02	PASS
-20	33.11	0.02	-33.47	-0.02	
-10	47.37	0.02	-39.72	-0.02	
0	42.11	0.02	-40.11	-0.02	
10	47.13	0.02	-37.98	-0.02	
20	-33.48	-0.02	-47.31	-0.02	
30	-63.14	-0.03	-49.33	-0.03	
40	-43.79	-0.02	39.97	0.02	
50	-53.17	-0.03	-44.31	-0.02	



<b>Band :</b>	WCDMA Band V	<b>Channel :</b>	4182
<b>Limit (ppm) :</b>	2.5		

Temperature (°C)	RMC 12.2Kbps		Result
	Freq. Dev. (Hz)	Deviation (ppm)	
-30	-27.19	-0.03	PASS
-20	-26.89	-0.03	
-10	-11.31	-0.01	
0	-17.32	-0.02	
10	13.07	0.02	
20	13.71	0.02	
30	-10.37	-0.01	
40	-17.62	-0.02	
50	28.31	0.03	

<b>Band :</b>	WCDMA Band II	<b>Channel :</b>	9400
<b>Limit (ppm) :</b>	2.5		

Temperature (°C)	RMC 12.2Kbps		Result
	Freq. Dev. (Hz)	Deviation (ppm)	
-30	-26.27	-0.01	PASS
-20	-26.19	-0.01	
-10	-11.37	-0.01	
0	-29.11	-0.02	
10	19.47	0.01	
20	16.47	0.01	
30	28.17	0.01	
40	22.97	0.01	
50	-37.12	-0.02	



<b>Band :</b>	CDMA2000 BC0	<b>Channel :</b>	384
<b>Limit (ppm) :</b>	2.5		

Temperature (°C)	1xRTT FCH_RC3+SO55		Result
	Freq. Dev. (Hz)	Deviation (ppm)	
-30	-33.17	-0.04	PASS
-20	-24.29	-0.03	
-10	19.37	0.02	
0	37.11	0.04	
10	41.97	0.05	
20	16.91	0.02	
30	-33.17	-0.04	
40	-39.27	-0.05	
50	-19.37	-0.02	

<b>Band :</b>	CDMA2000 BC1	<b>Channel :</b>	600
<b>Limit (ppm) :</b>	2.5		

Temperature (°C)	1xRTT FCH_RC3+SO55		Result
	Freq. Dev. (Hz)	Deviation (ppm)	
-30	-13.47	-0.01	PASS
-20	-16.13	-0.01	
-10	19.71	0.01	
0	16.33	0.01	
10	18.46	0.01	
20	14.33	0.01	
30	12.41	0.01	
40	-13.01	-0.01	
50	-14.11	-0.01	



3.7.7 Test Result of Voltage Variation

Band & Channel	Mode	Voltage (Volt)	Freq. Dev. (Hz)	Deviation (ppm)	Limit (ppm)	Result
GSM 850 CH189	GSM	3.8	33.12	0.04	2.5	PASS
		BEP	43.12	0.05		
		4.2	27.01	0.03		
	EDGE 8	3.8	36.17	0.04		
		BEP	43.01	0.05		
		4.2	37.12	0.04		
GSM 1900 CH661	GSM	3.8	-66.30	-0.03		
		BEP	-49.61	-0.03		
		4.2	-67.18	-0.04		
	EDGE 8	3.8	-47.18	-0.02		
		BEP	-46.31	-0.02		
		4.2	43.18	0.02		
WCDMA Band V CH4182	RMC 12.2Kbps	3.8	-27.89	-0.03		
		BEP	-27.30	-0.03		
		4.2	-26.96	-0.03		
WCDMA Band II CH9400	RMC 12.2Kbps	3.8	-26.70	-0.01		
		BEP	-26.34	-0.01		
		4.2	-27.48	-0.01		
CDMA2000 BC0 CH384	1xRTT FCH_RC3+ SO55	3.8	19.31	0.02		
		BEP	-42.17	-0.05		
		4.2	-24.21	-0.03		
CDMA2000 BC1 CH600	1xRTT FCH_RC3+ SO55	3.8	-13.17	-0.01		
		BEP	22.43	0.01		
		4.2	-17.31	-0.01		

Note:

1. Normal Voltage = 3.8V.
2. Battery End Point (BEP) = 3.55 V.



## 4 List of Measuring Equipment

Instrument	Manufacturer	Model No.	Serial No.	Characteristics	Calibration Date	Due Date	Remark
System Simulator	R&S	CMU200	116456	N/A	Jun. 05, 2008	Jun. 04, 2010	Conducted (TH02-HY)
Spectrum Analyzer	R&S	FSP40	100055	9kHz~40GHz	Jun. 23, 2009	Jun. 22, 2010	Conducted (TH02-HY)
Thermal Chamber	TEN BILLION	TTH-D35P	TBN-930701	N/A	Jul. 29, 2009	Jul. 28, 2010	Conducted (TH02-HY)
Bilog Antenna	SCHAFFNER	CBL6111C	2726	30MHz ~ 1GHz	Oct. 31, 2009	Oct. 30, 2010	Radiation (03CH07-HY)
Spectrum Analyzer	R&S	FSP	101067	9KHz ~ 30GHz	Dec. 04, 2009	Dec. 03, 2010	Radiation (03CH07-HY)
Double Ridge Horn Antenna	ESCO	3117	00075962	1GHz ~ 18GHz	Aug. 20, 2009	Aug. 19, 2010	Radiation (03CH07-HY)
SHF-EHF Horn Antenna	SCHWARZBECK	BBHA 9170	BBHA917025 1	15GHz- 40GHz	Oct. 14, 2009	Oct. 13, 2010	Radiation (03CH07-HY)
Pre Amplifier	Agilent	8449B	3008A02362	1GHz~ 26.5GHz	Dec.09,2009	Dec. 08, 2010	Radiation (03CH07-HY)
Pre Amplifier	COM-POWER	PA-103A	161241	10-1000MHz.32dB. GAIN	Mar. 27, 2009	Mar. 26, 2010	Radiation (03CH07-HY)
Loop Antenna	R&S	HFH2-Z2	860004/001	9 KHz~30 MHz	May 22, 2008	May 21, 2010	Radiation (03CH07-HY)
System Simulator	R&S	CMU200	117997	N/A	May 14, 2009	May 13, 2011	-



## 5 Uncertainty of Evaluation

### Uncertainty of Radiated Emission Measurement (30 MHz ~ 1000 MHz)

Contribution	Uncertainty of $X_i$		$u(X_i)$
	dB	Probability Distribution	
Receiver Reading	0.41	Normal (k=2)	0.21
Antenna Factor Calibration	0.83	Normal (k=2)	0.42
Cable Loss Calibration	0.25	Normal (k=2)	0.13
Pre-Amplifier Gain Calibration	0.27	Normal (k=2)	0.14
RCV/SPA Specification	2.50	Rectangular	0.72
Antenna Factor Interpolation for Frequency	1.00	Rectangular	0.29
Site Imperfection	1.43	Rectangular	0.83
Mismatch	+0.39 / -0.41	U-Shape	0.28
<b>Combined Standard Uncertainty <math>U_c(y)</math></b>	<b>1.27</b>		
<b>Measuring Uncertainty for a Level of Confidence of 95% (<math>U = 2U_c(y)</math>)</b>	<b>2.54</b>		

### Uncertainty of Radiated Emission Measurement (1 GHz ~ 40 GHz)

Contribution	Uncertainty of $X_i$		$u(X_i)$	$C_i$	$C_i * u(X_i)$
	dB	Probability Distribution			
Receiver Reading	$\pm 0.10$	Normal (k=2)	0.10	1	0.10
Antenna Factor Calibration	$\pm 1.70$	Normal (k=2)	0.85	1	0.85
Cable Loss Calibration	$\pm 0.50$	Normal (k=2)	0.25	1	0.25
Receiver Correction	$\pm 2.00$	Rectangular	1.15	1	1.15
Antenna Factor Directional	$\pm 1.50$	Rectangular	0.87	1	0.87
Site Imperfection	$\pm 2.80$	Triangular	1.14	1	1.14
Mismatch Receiver VSWR $\Gamma_1 = 0.197$ Antenna VSWR $\Gamma_2 = 0.194$ Uncertainty = $20\text{Log}(1-\Gamma_1*\Gamma_2)$	+0.34 / -0.35	U-Shape	0.244	1	0.244
<b>Combined Standard Uncertainty <math>U_c(y)</math></b>	<b>2.36</b>				
<b>Measuring Uncertainty for a Level of Confidence of 95% (<math>U = 2U_c(y)</math>)</b>	<b>4.72</b>				



## **Appendix A. Photographs of EUT**

Please refer to Sporton report number EP010801 as below.