



No.198 Kezhu Road, Science Town Economic& Technology
Development District Guangzhou, China 510663
Telephone: +86 (0) 20 82155555
Fax: +86 (0) 20 82075059
Email: sgs_internet_operations@sgs.com

FEDERAL COMMUNICATIONS COMMISSION
Registration number: 282399

Report No.: GLEMR070100204RFF
Page: 1 of 42
FCC ID: UZ5-BUD2000001

TEST REPORT

Application No. : GLEMR070100204RF
Applicant: Phoenix International Co., Ltd
FCC ID: UZ5-BUD2000001
Fundamental Carrier
Frequency : 2.402GHz to 2.480GHz
Equipment Under Test (EUT):
Name: Bluetooth USB Dongle
Model No.: BUD-210,BUD-200*
Trade Mark: PHOENIX
Standards: FCC PART 15, SUBPART C: 2006 (Section 15.247);
Date of Receipt: 25 January 2007
Date of Test: 29 January to 2 February 2007
Date of Issue: 6 January 2007

Test Result :	PASS *
----------------------	---------------

* In the configuration tested, the EUT detailed in this report complied with the standards specified above. Please refer to section 2 of this report for further details.

Authorized Signature:

Jerry Chen
Manager

This report refers to the General Conditions for Inspection and Testing Services, printed overleaf
This report details the results of the testing carried out on one sample. The results contained in this test report do not relate to other samples of the same product. The manufacturer should ensure that all products in series production are in conformity with the product sample detailed in this report.

This report may only be reproduced and distributed in full. If the product in this report is used in any configuration other than that detailed in the report, the manufacturer must ensure the new system complies with all relevant standards. Any mention of SGS International Electrical Approvals or testing done by SGS International Electrical Approvals in connection with, distribution or use of the product described in this report must be approved by SGS International Electrical Approvals in writing.



2 Test Summary

For Bluetooth Function:			
Test	Test Requirement	Standard Paragraph	Result
Maximum Peak Output Power	FCC PART 15 :2006	Section 15.247(b)(1)	PASS
Conducted Emission	FCC PART 15 :2006	15.207	PASS
Conducted Spurious Emission (30MHz to 25GHz)	FCC PART 15 :2006	Section 15.247(d)	PASS
Radiated Spurious Emission (30MHz to 25GHz)	FCC PART 15 :2006	Section 15.209 &15.247(d)	PASS
Band Edges Measurement	FCC PART 15 :2006	Section 15.247 (d) &15.205	PASS
Hopping Channel Number	FCC PART 15 :2006	Section 15.247(a)(1)(iii)	PASS
Carrier Frequencies Separated	FCC PART 15 :2006	Section 15.247(a)(1)	PASS
Dwell Time	FCC PART 15 :2006	Section 15.247(a)(1)(iii)	PASS
Antenna Requirement	FCC PART 15 :2006	Section 15.247 (c)	PASS

Remark: According to the confirmation from the applicant, model BUD-210,BUD-200 are same as in the circuit, PCB layout, electrical parts without the appearance. Only one model need to test.



3 Contents

	Page
1 COVER PAGE	1
2 TEST SUMMARY	2
3 CONTENTS	3
4 GENERAL INFORMATION	4
4.1 CLIENT INFORMATION.....	4
4.2 GENERAL DESCRIPTION OF E.U.T.	4
4.3 DESCRIPTION OF SUPPORT UNITS	4
4.4 STANDARDS APPLICABLE FOR TESTING.....	4
4.5 TEST LOCATION.....	5
4.6 OTHER INFORMATION REQUESTED BY THE CUSTOMER	5
4.7 TEST FACILITY	5
5 EQUIPMENTS USED DURING TEST.....	6
6 TEST RESULTS	7
6.1 E.U.T. OPERATION	7
6.2 MAXIMUM PEAK OUTPUT POWER	8
6.3 CONDUCTED EMISSIONS MAINS TERMINALS, 150KHZ TO 30MHZ.....	11
6.4 CONDUCTED SPURIOUS EMISSIONS.....	14
6.5 RADIATED SPURIOUS EMISSIONS.....	18
6.6 BAND EDGES REQUIREMENT	26
6.6.1 100 kHz Bandwidth Outside the Frequency Band.....	26
6.6.2 Radiated Emissions which fall in the restricted bands	28
6.7 HOPPING CHANNEL NUMBER.....	31
6.8 OCCUPIED BANDWIDTH.....	32
6.9 CARRIER FREQUENCIES SEPARATED	34
6.10 DWELL TIME	36
6.11 ANTENNA REQUIREMENT.....	42
6.11.1 Standard Applicable.....	42
6.11.2 Antenna Construction	42

4 General Information

4.1 Client Information

Applicant Name: Phoenix International Co., Ltd
Applicant Address: 11F, No.42-1, Sec.1, Zhong-Yang N. Rd. Peitou, Taipei 112, Taiwan, R.O.C.

4.2 General Description of E.U.T.

Name: Bluetooth USB Dongle
Model No.: BUD-210, BUD-200
Trade Mark: PHOENIX
Bluetooth Specification: Bluetooth V2.0 + EDR
Number of Channels: 79 Channels
Channel Separation: 1 MHz
Type of Modulation: FHSS (Frequency Hopping Spread Spectrum)
Dwell time: Per channel is less than 0.4S.
Antenna Type: Integral
Power Supply: By host PC USB socket.

4.3 Description of Support Units

The EUT has been tested with a PC system as following:

Description	Manufacturer	Model No.	Serial No.
Personal Computer	Hewlett-Packard	P7314A	CN21003501
NoteBook	IBM	2374-14N	99-FBAF9
17" Monitor	Philips	107P20/29H	BZ000144445038
Mouse	Hewlett-Packard	M-S480	LZE20353501 FCC ID: JNZ201213
ROM Programmer	DASI Electronics	EMP-100A	J007
Printer	Epson	P310B	DLRE134863
Personal Computer	IBM	M/T 3126-KCH	99F6434
Personal Computer	IBM	M/T 8189-39C	99FX366
15" Monitor	IBM	6331-4CN	23-NTYF6
17" Monitor	IBM	6737-66N/A	23-NG949

4.4 Standards Applicable for Testing

The customer requested FCC tests for the EUT.

The standard used was FCC PART 15, SUBPART C (2006) section 15.247.



4.5 Test Location

All tests were performed at:

SGS-CSTC Standards Technical Services Co., Ltd., Guangzhou EMC Laboratory, No.198 Kezhu Road, Science Town Economic& Technology Development District Guangzhou, China 510663

Tel: +86 20 82155555 Fax: +86 20 82075059

No tests were sub-contracted.

4.6 Other Information Requested by the Customer

None.

4.7 Test Facility

The test facility is recognized, certified, or accredited by the following organizations:

- **NVLAP (Lab Code: 200611-0)**

SGS-CSTC Standards Technical Services Co., Ltd., Guangzhou EMC Laboratory is recognized under the National Voluntary Laboratory Accreditation Program (NVLAP/NIST). NVLAP Code: 200611-0.

- **CNAS (Lab Code: L0167)**

SGS-CSTC Standards Technical Services Co., Ltd., EMC Laboratory has been assessed and in compliance with CNAS-CL01:2006 accreditation criteria for testing laboratories (identical to ISO/IEC 17025:2005 General Requirements) for the Competence of Testing Laboratories.

- **FCC (Registration No.: 282399)**

SGS-CSTC Standards Technical Services Co., Ltd., EMC Laboratory has been registered and fully described in a report filed with the (FCC) Federal Communications Commission. The acceptance letter from the FCC is maintained in our files. Registration 282399, May 31, 2002. With the above and NVLAP's accreditation, SGS-CSTC is an authorized test laboratory for the DoC process.

- **Industry Canada (Registration No.: 4620B-1)**

The 3m/10m Alternate Semi-anechoic chamber of SGS-CSTC Standards Technical Services Co., Ltd. has been registered by Certification and Engineering Bureau of Industry Canada for radio equipment testing with Registration No.: 4620B-1.

Date of Registration: Jan 15, 2007. Valid until Jan 15, 2009

5 Equipments Used during Test

Conducted Emission						
No:	Test Equipment	Manufacturer	Model No.	Serial No.	Cal. Date (dd-mm-yy)	Cal.Due date (dd-mm-yy)
EMC0306	Shielding Room	Zhong Yu	8 x 3 x 3.8 m ³	N/A	N/A	N/A
EMC0102	LISN	Schaffner Chase	MNZ050D/1	1421	05-12-2006	05-12-2007
EMC0506	EMI Test Receiver	Rohde & Schwarz	ESCS30	100085	05-12-2006	05-12-2007
EMC0107	Coaxial Cable	SGS	2m	N/A	25-11-2006	25-11-2007

RE in Chamber/OATS						
No:	Test Equipment	Manufacturer	Model No.	Serial No.	Cal. Date (dd-mm-yy)	Cal.Due date (dd-mm-yy)
EMC0525	Compact Semi-Anechoic Chamber	ChangZhou ZhongYu	N/A	N/A	06-03-2006	06-03-2007
EMC0522	EMI Test Receiver	Rohde & Schwarz	ESIB26	100249	05-12-2006	05-12-2007
N/A	EMI Test Software	Audix	E3	N/A	N/A	N/A
EMC0514	Coaxial cable	SGS	N/A	N/A	04-12-2006	04-12-2007
EMC0524	Bi-log Type Antenna	Schaffner -Chase	CBL6112B	2966	31-10-2006	31-10-2007
EMC0519	Bilog Type Antenna	Schaffner -Chase	CBL6143	5070	31-07-2006	31-07-2007
EMC0517	Horn Antenna	Rohde & Schwarz	HF906	100095	29-07-2006	29-07-2007
EMC0040	Spectrum Analyzer	Rohde & Schwarz	FSP30	100324	05-12-2006	05-12-2007
EMC0520	0.1-1300 MHz Pre-Amplifier	HP	8447D OPT 010	2944A06252	06-03-2006	06-03-2007
EMC0521	1-26.5 GHz Pre-Amplifier	Agilent	8449B	3008A01649	06-03-2006	06-03-2007
EMC0523	Active Loop Antenna	EMCO	6502	00042963	09-08-2006	09-08-2008
EMC0530	10m Semi- Anechoic Chamber	ETS	N/A	N/A	22-08-2006	22-08-2007

General used equipment						
No:	Test Equipment	Manufacturer	Model No.	Serial No.	Cal. Date (dd-mm-yy)	Cal.Due date (dd-mm-yy)
EMC0050-EMC0053	Temperature, & Humidity	ZHENGZHOU BO YANG	WSB	N/A	05-12-2006	05-12-2007
EMC0054	Temperature, & Humidity	Shenzhen Tai Kong	THG-1	N/A	04-01-2007	04-01-2008
EMC0006	DMM	Fluke	73	70681569	27-09-2006	27-09-2007
EMC0007	DMM	Fluke	73	70671122	27-09-2006	27-09-2007



6 Test Results

6.1 E.U.T. Operation

Input voltage: By host PC USB socket.

Operating Environment:

Temperature: 20.0 -22.0 °C

Humidity: 38-48 % RH

Atmospheric Pressure: 992 -1006 mbar

EUT Operation: Test the EUT as a product which has frequency hopping system. The total hopping channels are 79 channels (0 to 78 channels), the fundamental frequencies are from 2.402GHz to 2.480GHz.

Test the EUT to transmit and receive data at lowest (**Channel 0: 2.402GHz**), middle (**Channel 39: 2.402GHz**), and highest channel (**Channel 78: 2.480GHz**), frequencies individually for the compliance test.

6.2 Maximum Peak Output Power

Test Requirement: FCC Part15 C
 Test Method: Base on ANSI 63.4.
 Test Date: 30 January 2007
 Test Limit:

Regulation 15.247 (b)(1) For frequency hopping systems operating in the 2400-2483.5 MHz band employing at least 75 non-overlapping hopping channels, and all frequency hopping systems in the 5725-5850 MHz band: 1 watt. For all other frequency hopping systems in the 2400-2483.5 MHz band: 0.125 watts.

The non-overlapping hopping channels of EUT over 75, the result refer to the result "Hopping channel number" of this document. So 1 watt limit applies.

Test mode: Test in transmitting mode: Channel 0, Channel 39, Channel 78.

Test Configuration:

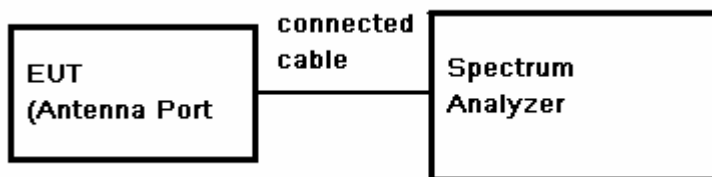

Test Procedure:

1. Remove the antenna from the EUT and then connect a low RF cable from the antenna port to the spectrum.
2. Set the spectrum analyzer: RBW = 1 MHz, VBW = 1 MHz, Sweep = auto; Detector Function = Peak.
3. Keep the EUT in transmitting at lowest, medium and highest channel individually. Record the max value.

Test Result:

Test Channel	Fundamental Frequency (GHz)	Reading Power (dBm)	Cable Loss (dB)	Output Power (dBm)	Limit (dBm)	PASS/FAIL
0	2.402	2.50	0.20	2.30	30.0	Pass
39	2.441	2.78	0.20	2.58	30.0	Pass
78	2.480	1.83	0.20	1.63	30.0	Pass

TEST RESULTS: The unit does meet the FCC requirements.



Max. Power Output Data Plot:

1. Lowest Channel:

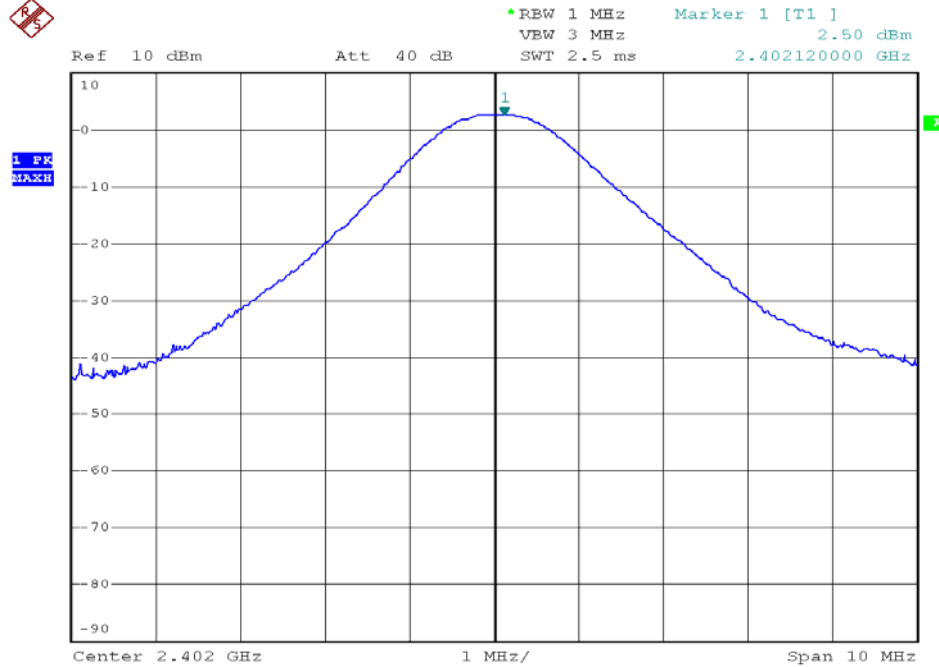

Date: 30.JAN.2007 16:08:55

2. Medium Channel:

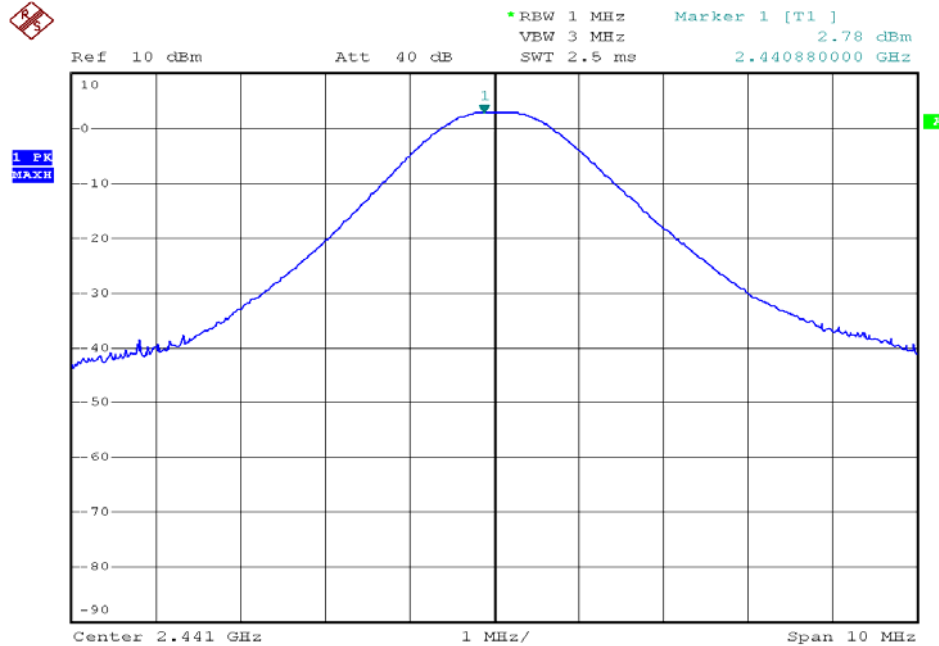

Date: 30.JAN.2007 16:10:49



3. Highest Channel:

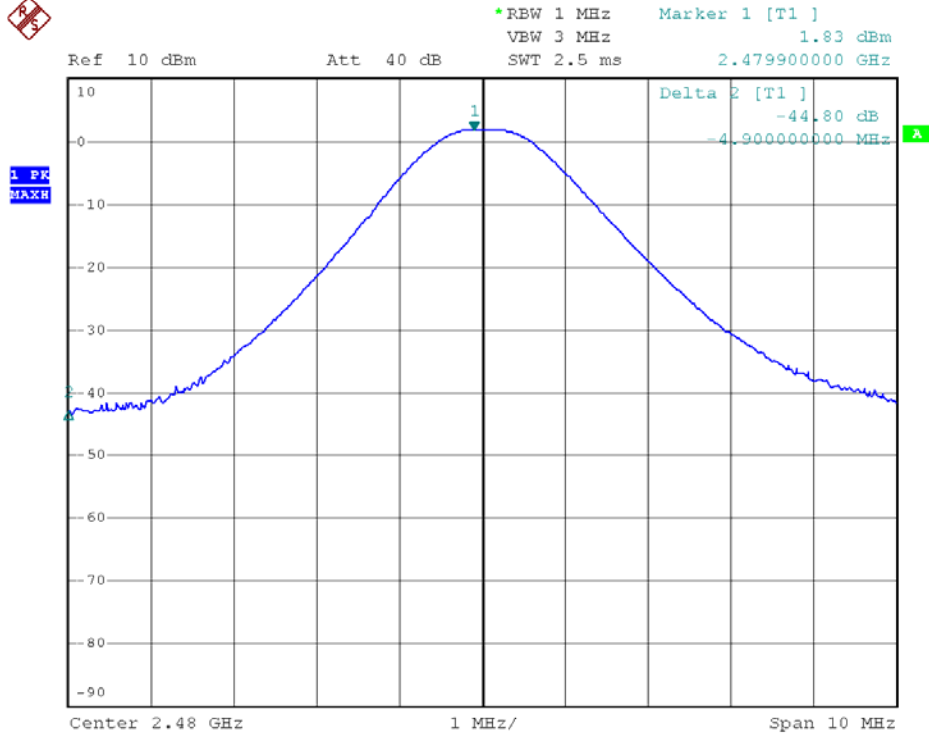

Date: 30.JAN.2007 16:03:05



6.3 Conducted Emissions Mains Terminals, 150kHz to 30MHz

Test Requirement: FCC Part 15.207
Test Method: ANSI C63.4
Test Date: 1 February 2007
Frequency Range: 150KHz to 30MHz
Class / Severity: Class B
Detector: Peak for pre-scan (9kHz Resolution Bandwidth)
Quasi-Peak if maximised peak within 6dB of Quasi-Peak limit.
EUT Operation: Test in connect PC with Bluetooth function on, keep the EUT in transmitting and receiving status.

Test result:

An initial pre-scan was performed on the live and neutral lines with peak detector.

Quasi-Peak and Average measurement were performed at the frequencies with maximized peak emission were detected.

The following Quasi-Peak and Average measurements were performed on the EUT on 1 February 2007:



Live Line:

Data: 4 File: F:\e3CE\Applc\ant\2007\0204RF (CE) PHOENIX INTERNATIONAL
 Level (dBuV) Date: 2-1-2007 Time: 10:46:17

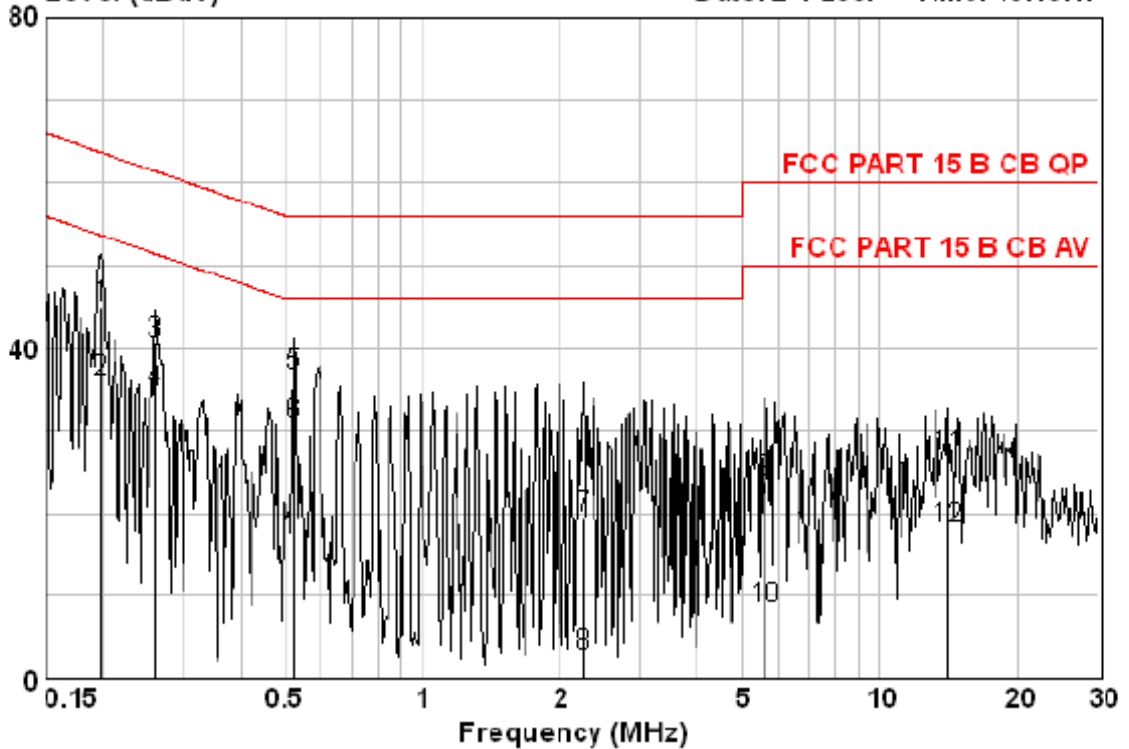

	Freq	Read Level	Cable Loss	LISN Factor	Level	Limit Line	Over Limit	Remark
	MHz	dBuV	dB	dB	dBuV	dBuV	dB	
1	0.198	45.04	0.00	0.00	45.04	63.71	-18.67	QP
2	0.198	35.94	0.00	0.00	35.94	53.71	-17.77	AVERAGE
3	0.262	40.68	0.00	0.00	40.68	61.38	-20.70	QP
4	0.262	34.64	0.00	0.00	34.64	51.38	-16.74	AVERAGE
5	0.527	36.76	0.00	0.00	36.76	56.00	-19.24	QP
6 MAX	0.527	30.70	0.00	0.00	30.70	46.00	-15.30	AVERAGE
7	2.249	19.38	0.04	0.00	19.42	56.00	-36.58	QP
8	2.249	2.66	0.04	0.00	2.70	46.00	-43.30	AVERAGE
9	5.623	23.80	0.08	0.00	23.88	60.00	-36.12	QP
10	5.623	8.43	0.08	0.00	8.51	50.00	-41.49	AVERAGE
11	14.063	26.56	0.16	0.00	26.72	60.00	-33.28	QP
12	14.063	17.86	0.16	0.00	18.02	50.00	-31.98	AVERAGE



Neutral Line

Data: 3 File: F:\e3CE\Applc\ant\2007\0204RF (CE) PHOENIX INTERNATIONAL
 Level (dBuV) Date: 2-1-2007 Time: 10:42:10

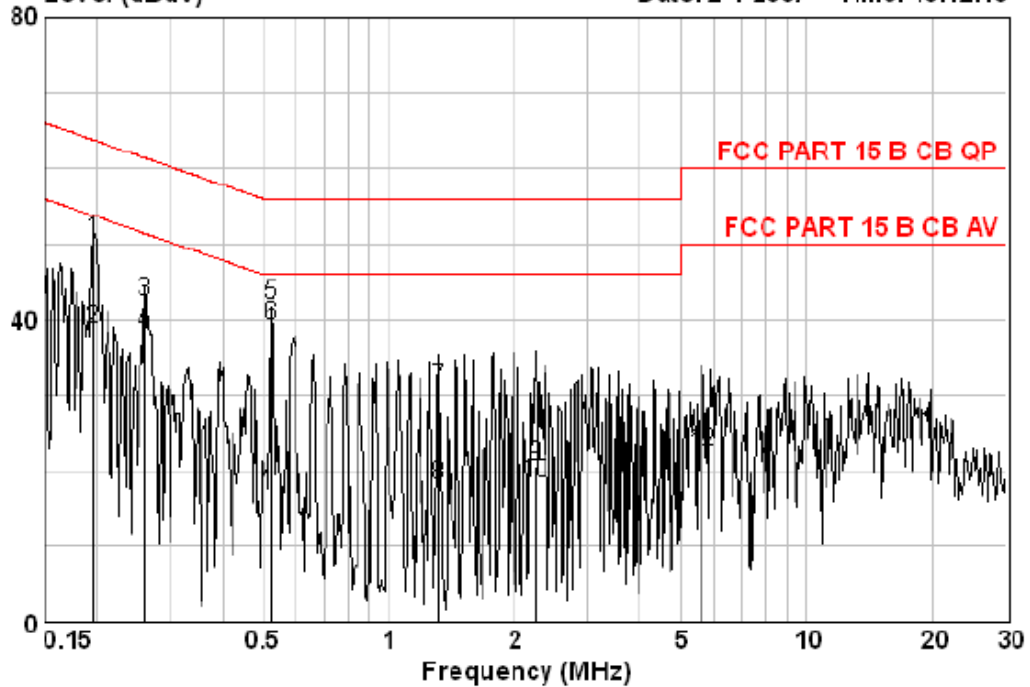

	Read	Cable	LISN	Limit	Over	
1	Freq	Loss	Factor	Line	Limit	Remark
	MHz	dB	dB	dBuV	dB	
1 MAX	0.197	50.48	0.00	0.00	50.48	63.76 -13.28 QP
2 MAX	0.197	38.67	0.00	0.00	38.67	53.76 -15.09 AVERAGE
3	0.262	42.50	0.00	0.00	42.50	61.38 -18.88 QP
4 MAX	0.262	38.14	0.00	0.00	38.14	51.38 -13.24 AVERAGE
5 MAX	0.523	41.90	0.00	0.00	41.90	56.00 -14.10 QP
6 MAX	0.523	39.14	0.00	0.00	39.14	46.00 -6.86 AVERAGE
7	1.310	30.94	0.01	0.00	30.95	56.00 -25.05 QP
8	1.310	18.09	0.01	0.00	18.10	46.00 -27.90 AVERAGE
9	2.249	20.66	0.04	0.00	20.70	56.00 -35.30 QP
10	2.249	18.26	0.04	0.00	18.30	46.00 -27.70 AVERAGE
11	5.623	21.86	0.08	0.00	21.94	60.00 -38.06 QP
12	5.623	22.33	0.08	0.00	22.41	50.00 -27.59 AVERAGE



6.4 Conducted Spurious Emissions

Test Requirement: FCC Part 15 C
Test Method: Based on FCC Part15 C Section 15.247:
Test Date: 30 January 2007
Test requirements: Regulation 15.247(d) In any 100 kHz bandwidth outside the frequency band in which the spread spectrum or digitally modulated intentional radiator is operating, the radio frequency power that is produced by the intentional radiator shall be at least 20 dB below that in the 100 kHz bandwidth within the band that contains the highest level of the desired power, based on either an RF conducted or a radiated measurement, provided the transmitter demonstrates compliance with the peak conducted power limits.

Test Procedure:

1. Remove the antenna from the EUT and then connect a low RF cable from the antenna port to the spectrum.
2. Set the spectrum analyzer: RBW = 100KHz, VBW \geq RBW (set 100KHz), Sweep = auto; Detector Function = Peak (Max. hold).



Test result:

Lowest Channel (channel 0)

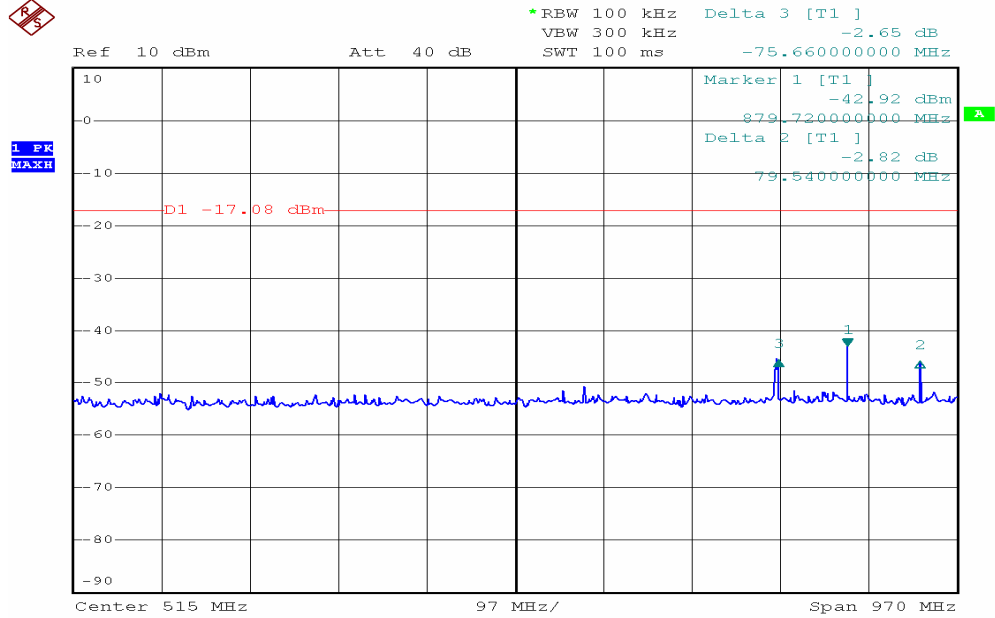

Date: 30.JAN.2007 16:47:24

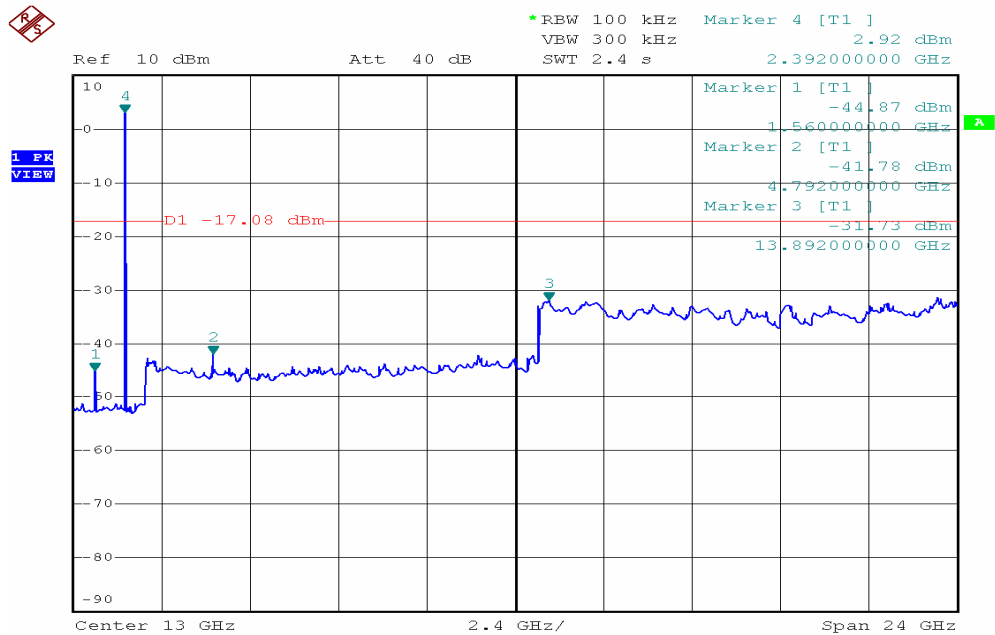

Date: 30.JAN.2007 16:46:04



Medium Channel (channel 39)

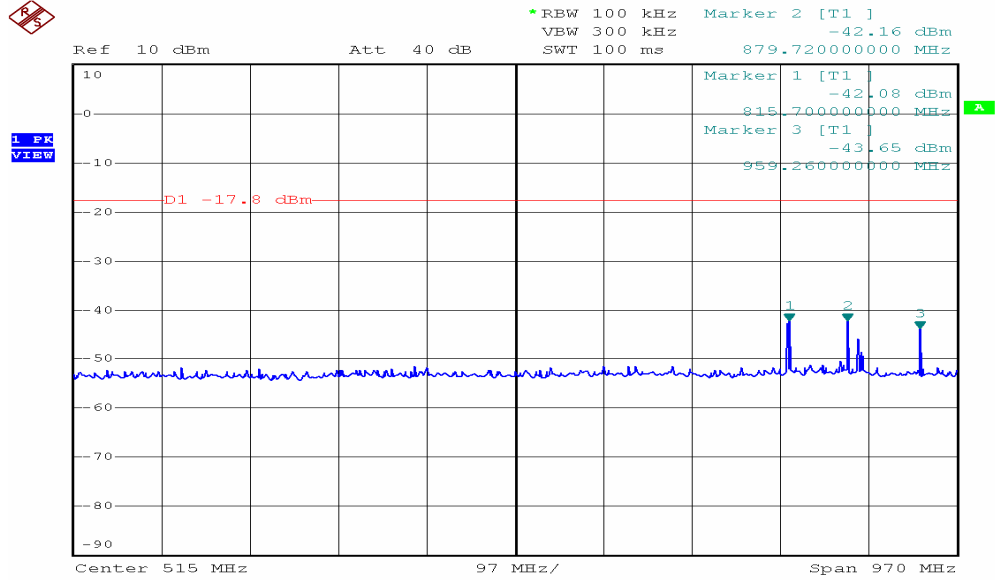

Date: 30.JAN.2007 16:38:07

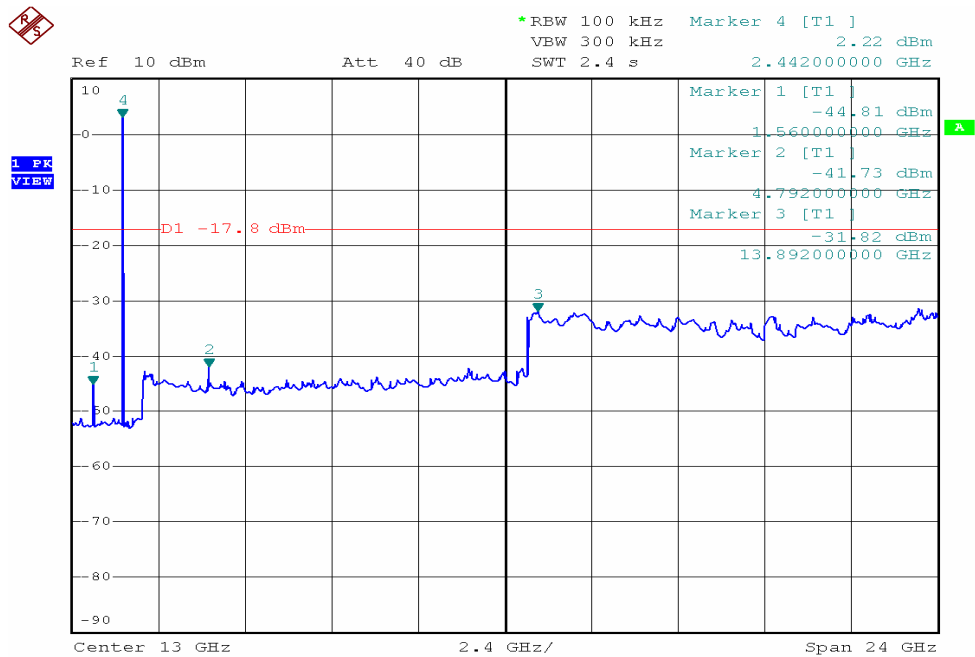

Date: 30.JAN.2007 16:44:04



Highest Channel (channel 78)

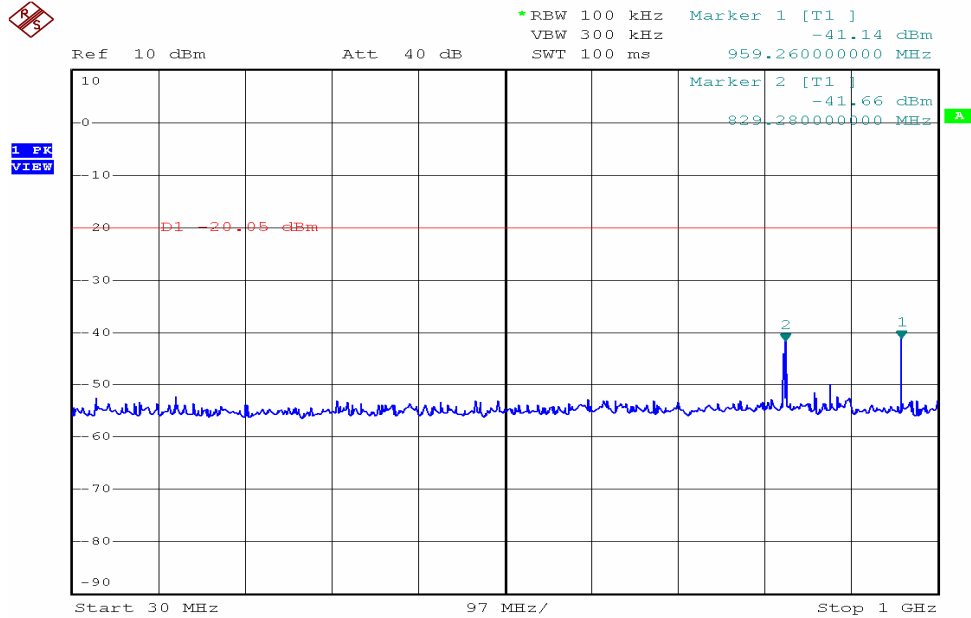

Date: 30.JAN.2007 16:54:00

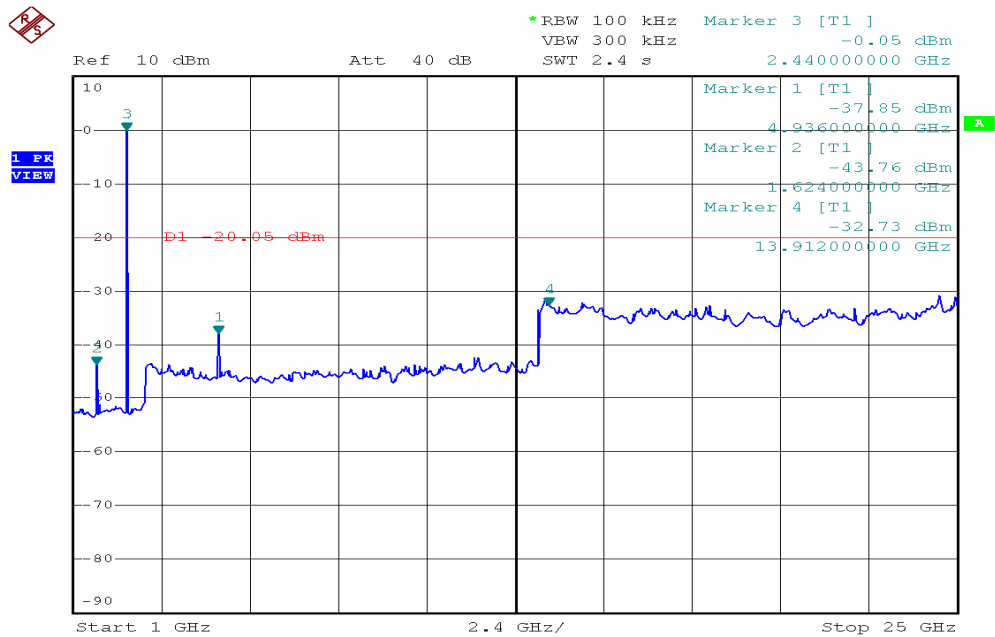

Date: 30.JAN.2007 16:52:39

6.5 Radiated Spurious Emissions

Test Requirement: FCC 15.247(d) & 15.209
 Test Method: ANSI C63.4 section 8 & 13
 Test Date: 30 January 2007
 Test site: Measurement Distance: 3m (Semi-Anechoic Chamber and OATS)
 Frequency range 30 MHz – 25GHz for transmitting mode.
 Test instrumentation resolution bandwidth 120 kHz and Quasi-Peak detector applies (30 MHz - 1000 MHz), 1 MHz resolution bandwidth and Peak and Average-Peak detector apply(1000 MHz – 25GHz).
 Receive antenna scan height 1 m - 4 m, polarization Vertical / Horizontal

15.209 Limit:
 40.0 dB μ V/m between 30MHz & 88MHz
 43.5 dB μ V/m between 88MHz & 216MHz
 46.0 dB μ V/m between 216MHz & 960MHz
 54.0 dB μ V/m above 960MHz

Test Configuration:

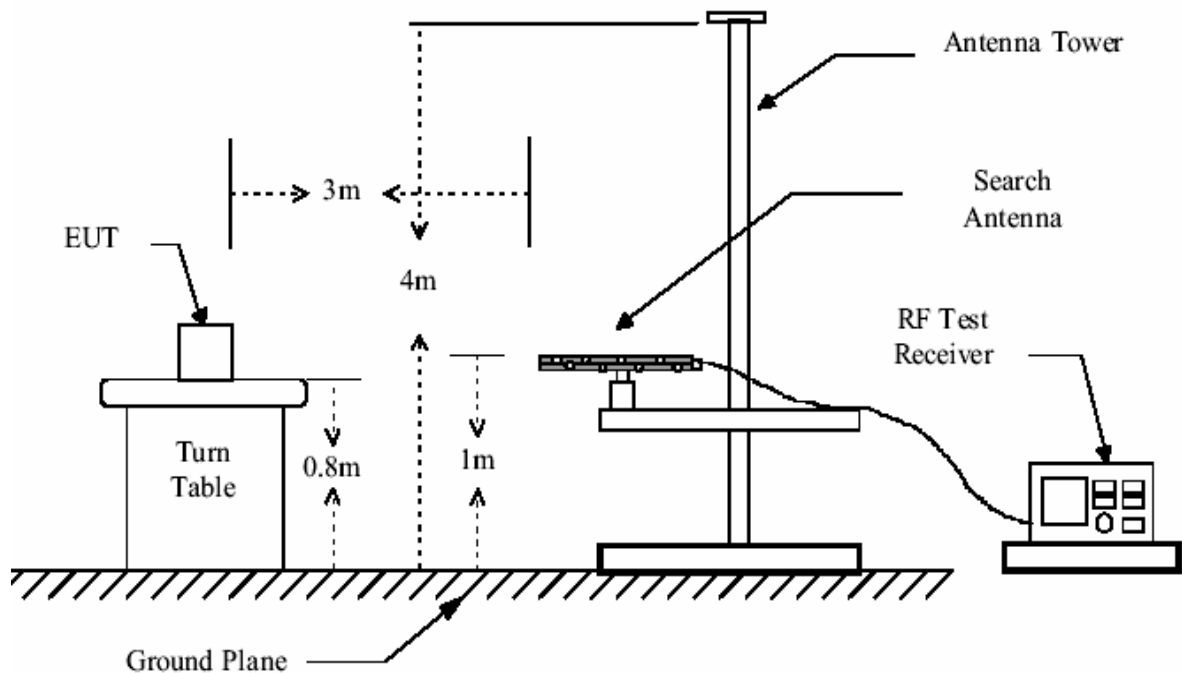

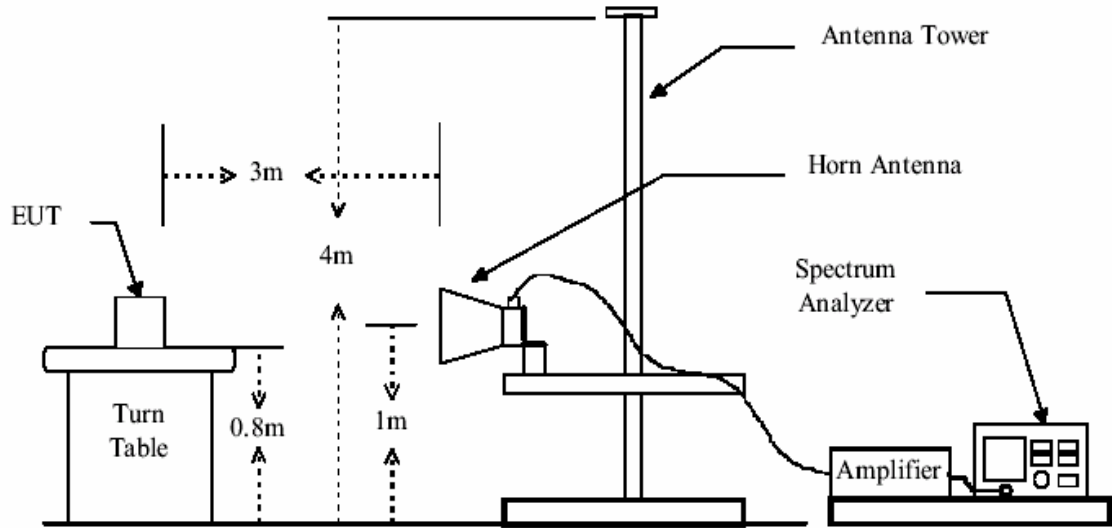

Test Procedure: The procedure used was ANSI Standard C63.4 2003. The receiver was scanned from 30MHz to 25GHz. When an emission was found, the table was rotated to produce the maximum signal strength. An initial pre-scan was performed for in peak detection mode using the receiver. The EUT was measured for both the Horizontal and Vertical polarities and performed a pre-test three orthogonal planes. For intentional radiators, measurements of the variation of the input power or the radiated signal level of the fundamental frequency component of the emission, as appropriate, shall be performed with the supply voltage varied between 85% and 115% of the nominal rated supply voltage. The worst case emissions were reported.

The field strength is calculated by adding the Antenna Factor, Cable Factor & Peramplifier. The basic equation with a sample calculation is as follows:

Final Test Level = Receiver Reading + Antenna Factor + Cable Factor – Peramplifier Factor

The following test results were performed on the EUT



Test in Channel 0 in transmitting status:

30MHz~1GHz Spurious Emissions ,Quasi-Peak Measurement

Frequency (MHz)	Antenna Polarization	Emission Level (dBuV/m)	Limit dBuV/m)	Margin (dB)
49.400	Vertical	27.6	40.0	12.4
124.090	Vertical	30.4	43.5	13.1
170.650	Vertical	25.5	43.5	18.0
219.150	Vertical	30.6	46.0	15.4
393.750	Vertical	25.0	46.0	21.0
797.270	Vertical	31.9	46.0	14.1
71.71	Horizontal	28.1	40.0	11.9
124.090	Horizontal	25.6	43.5	18.0
164.830	Horizontal	32.1	43.5	11.4
225.940	Horizontal	30.7	46.0	15.3
309.360	Horizontal	26.4	46.0	19.6
389.870	Horizontal	25.6	46.0	20.4

Test in Channel 0 in transmitting status:

1~25 GHz Harmonics & Spurious Emissions

Peak Measurement

Test Frequency (GHz)	Measuring Level (dBuV/m)		Limits (dBuV/m)	Margin (dB)	
	Vertical	Horizontal		Vertical	Horizontal
2) 4.804	40.5	41.0	74.0	33.5	33.0
3) 7.206	42.2	41.2	74.0	31.8	32.8
4) 9.608	N/A	N/A	74.0	N/A	N/A
5) 12.010	N/A	N/A	74.0	N/A	N/A
6) 14.412	N/A	N/A	74.0	N/A	N/A
7) 16.814	N/A	N/A	74.0	N/A	N/A
8) 19.216	N/A	N/A	74.0	N/A	N/A
9) 21.618	N/A	N/A	74.0	N/A	N/A
10) 24.020	N/A	N/A	74.0	N/A	N/A
Average Measurement					
2) 4.804	31.2	32.0	54.0	22.8	22.0
3) 7.206	30.2	33.7	54.0	23.8	20.3
4) 9.608	N/A	N/A	54.0	N/A	N/A



5)	12.010	N/A	N/A	54.0	N/A	N/A
6)	14.412	N/A	N/A	54.0	N/A	N/A
7)	16.814	N/A	N/A	54.0	N/A	N/A
8)	19.216	N/A	N/A	54.0	N/A	N/A
9)	21.618	N/A	N/A	54.0	N/A	N/A
10)	24.020	N/A	N/A	54.0	N/A	N/A

N/A: refer to remark 1).

Test in Channel 39 in transmitting status:

30MHz~1GHz Spurious Emissions ,Quasi-Peak Measurement

Frequency (MHz)	Antenna Polarization	Emission Level (dBuV/m)	Limit dBuV/m)	Margin (dB)
30.562	Vertical	24.6	40.0	15.4
91.325	Vertical	26.2	43.5	17.3
185.227	Vertical	26.9	43.5	16.6
263.254	Vertical	29.3	46.0	16.7
568.587	Vertical	27.8	46.0	18.2
841.362	Vertical	30.2	46.0	15.8
36.221	Horizontal	24.8	40.0	15.2
59.366	Horizontal	25.6	43.5	17.9
165.020	Horizontal	28.7	43.5	14.8
220.362	Horizontal	27.6	46.0	18.4
449.336	Horizontal	28.6	46.0	17.4
698.714	Horizontal	28.4	46.0	17.6

Test in Channel 39 in transmitting status:

1~25GHz Harmonics & Spurious Emissions:

Peak Measurement

Test Frequency (GHz)	Measuring Level (dBuV/m)		Limits (dBuV/m)	Margin (dB)	
	Vertical	Horizontal		Vertical	Horizontal
11) 4.882	41.5	41.6	74.0	32.5	32.4
12) 7.323	43.0	40.5	74.0	31.0	33.5
13) 9.764	N/A	N/A	74.0	N/A	N/A
14) 12.205	N/A	N/A	74.0	N/A	N/A
15) 14.646	N/A	N/A	74.0	N/A	N/A
16) 17.087	N/A	N/A	74.0	N/A	N/A



17)	19.528	N/A	N/A	74.0	N/A	N/A
18)	21.969	N/A	N/A	74.0	N/A	N/A
19)	24.410	N/A	N/A	74.0	N/A	N/A
Average Measurement						
11)	4.882	31.0	32.5	54.0	23.0	21.5
12)	7.323	30.3	33.2	54.0	23.7	20.8
13)	9.764	N/A	N/A	54.0	N/A	N/A
14)	12.205	N/A	N/A	54.0	N/A	N/A
15)	14.646	N/A	N/A	54.0	N/A	N/A
16)	17.087	N/A	N/A	54.0	N/A	N/A
17)	19.528	N/A	N/A	54.0	N/A	N/A
18)	21.969	N/A	N/A	54.0	N/A	N/A
19)	24.410	N/A	N/A	54.0	N/A	N/A

N/A: refer to remark 1).

Test in Channel 78 in transmitting status:

30MHz~1GHz Spurious Emissions ,Quasi-Peak Measurement

Frequency (MHz)	Antenna Polarization	Emission Level (dBUV/m)	Limit dBUV/m)	Margin (dB)
31.257	Vertical	24.9	40.0	15.1
89.365	Vertical	26.8	43.5	16.7
200.254	Vertical	30.2	43.5	13.3
354.241	Vertical	29.6	46.0	16.4
452.012	Vertical	31.2	46.0	14.8
598.251	Vertical	32.6	46.0	13.4
30.258	Horizontal	26.5	40.0	13.5
94.268	Horizontal	27.1	43.5	16.4
162.002	Horizontal	29.5	43.5	14.0
324.112	Horizontal	32.1	46.0	13.9
421.125	Horizontal	34.0	46.0	12.0
521.110	Horizontal	33.6	46.0	12.4



Test in Channel 78 in transmitting status:

1~25GHz Harmonics & Spurious Emissions:

Peak Measurement

Test Frequency (GHz)	Measuring Level (dBuV/m)		Limits (dBuV/m)	Margin (dB)	
	Vertical	Horizontal		Vertical	Horizontal
20) 4.960	40.6	41.5	74.0	33.4	32.5
21) 7.440	42.0	40.2	74.0	32.0	33.8
22) 9.920	N/A	N/A	74.0	N/A	N/A
23) 12.400	N/A	N/A	74.0	N/A	N/A
24) 14.880	N/A	N/A	74.0	N/A	N/A
25) 17.360	N/A	N/A	74.0	N/A	N/A
26) 19.840	N/A	N/A	74.0	N/A	N/A
27) 22.320	N/A	N/A	74.0	N/A	N/A
28) 24.800	N/A	N/A	74.0	N/A	N/A

Average Measurement

20) 4.960	31.2	32.5	54.0	22.8	21.5
21) 7.440	30.2	33.7	54.0	23.8	20.3
22) 9.920	N/A	N/A	54.0	N/A	N/A
23) 12.400	N/A	N/A	54.0	N/A	N/A
24) 14.880	N/A	N/A	54.0	N/A	N/A
25) 17.360	N/A	N/A	54.0	N/A	N/A
26) 19.840	N/A	N/A	54.0	N/A	N/A
27) 22.320	N/A	N/A	54.0	N/A	N/A
28) 24.800	N/A	N/A	54.0	N/A	N/A

N/A: refer to remark 1).



Remark:

- 1). N/A: For this intentional radiator operates below 25 GHz, the spectrum shall be investigated to the tenth harmonic of the highest fundamental frequency. And above the third harmonic of this intentional radiator, the disturbance is very low. So the test result only displays to 3rd harmonic.

- 2). According to 15.249 (d) As shown in Section 15.35(b), for frequencies above 1000 MHz, the above field strength limits are based on average limits. However, the peak field strength of any emission shall not exceed the maximum permitted average limits specified above by more than 20 dB under any condition of modulation.

Test in Channel 0 in Receiving status:

30MHz~1GHz Spurious Emissions ,Quasi-Peak Measurement

Frequency (MHz)	Antenna Polarization	Emission Level (dBuV/m)	Limit dBuV/m)	Margin (dB)
30.000	Vertical	24.3	40.0	15.7
80.000	Vertical	25.2	43.5	18.3
200.000	Vertical	24.6	43.5	18.9
300.000	Vertical	26.8	46.0	19.2
500.000	Vertical	27.2	46.0	18.8
800.000	Vertical	29.3	46.0	16.7
30.000	Horizontal	25.1	40.0	14.9
80.000	Horizontal	29.2	43.5	14.3
200.000	Horizontal	28.3	43.5	15.2
300.000	Horizontal	29.3	46.0	16.7
500.000	Horizontal	27.6	46.0	18.4
800.000	Horizontal	30.1	46.0	15.9

Test in Channel 39 in Receiving status:

30MHz~1GHz Spurious Emissions ,Quasi-Peak Measurement

Frequency (MHz)	Antenna Polarization	Emission Level (dBuV/m)	Limit dBuV/m)	Margin (dB)
30.000	Vertical	25.9	40.0	14.1
80.000	Vertical	29.6	43.5	13.9
200.000	Vertical	28.7	43.5	14.8
300.000	Vertical	29.4	46.0	16.6
500.000	Vertical	25.8	46.0	20.2



800.000	Vertical	27.6	46.0	18.4
30.000	Horizontal	27.1	40.0	12.9
80.000	Horizontal	26.5	43.5	17.0
200.000	Horizontal	28.2	43.5	15.3
300.000	Horizontal	26.1	46.0	19.9
500.000	Horizontal	30.4	46.0	15.6
800.000	Horizontal	28.0	46.0	18.0

Test in Channel 78 in Receiving status:

30MHz~1GHz Spurious Emissions ,Quasi-Peak Measurement

Frequency (MHz)	Antenna Polarization	Emission Level (dBuV/m)	Limit dBuV/m)	Margin (dB)
30.000	Vertical	27.1	40.0	12.9
80.000	Vertical	24.3	43.5	19.2
200.000	Vertical	25.1	43.5	18.4
300.000	Vertical	26.2	46.0	19.8
500.000	Vertical	24.8	46.0	21.2
800.000	Vertical	29.6	46.0	16.4
30.000	Horizontal	26.7	40.0	13.3
80.000	Horizontal	29.3	43.5	14.2
200.000	Horizontal	27.3	43.5	16.2
300.000	Horizontal	26.9	46.0	19.1
500.000	Horizontal	29.3	46.0	16.7
800.000	Horizontal	27.3	46.0	18.7

TEST RESULTS: The unit does meet the FCC requirements.



6.6 Band Edges Requirement

Test Requirement:	FCC Part 15 C
Test Method:	Based on ANSI 63.4 Operation within the band 2400 – 2483.5 MHz
Test Date:	30 January 2007
Requirements:	Section 15.247 (d) In any 100 kHz bandwidth outside the frequency band in which the spread spectrum or digitally modulated intentional radiator is operating, the radio frequency power that is produced by the intentional radiator shall be at least 20 dB below that in the 100 kHz bandwidth within the band that contains the highest level of the desired power, based on either an RF conducted or a radiated measurement, provided the transmitter demonstrates compliance with the peak conducted power limits. If the transmitter complies with the conducted power limits based on the use of RMS averaging over a time interval, as permitted under paragraph (b)(3) of this section, the attenuation required under this paragraph shall be 30 dB instead of 20 dB. Attenuation below the general limits specified in Section 15.209(a) is not required. In addition, radiated emissions which fall in the restricted bands, as defined in Section 15.205(a), must also comply with the radiated emission limits specified in Section 15.209(a) (see Section 15.205(c)).

6.6.1 100 kHz Bandwidth Outside the Frequency Band

Method of Measurement:	Set RBW of spectrum analyzer to 100 kHz and VBW of spectrum analyzer to 100 kHz with suitable frequency span including 100 kHz bandwidth from band edge. The band edges was measured and recorded.
------------------------	---

Test Result:

The Lower Edge 2.4000GHz: the value is -33.66dB that is attenuated more than 20dB.

The Upper Edge 2.4835GHz: the value is -47.21dB that is attenuated more than 20dB.

The unit does meet the FCC requirements.

The graph as below, represents the emissions take for this device.



1. For Lowest Channel: the fundamental frequency is **2.402G Hz.**

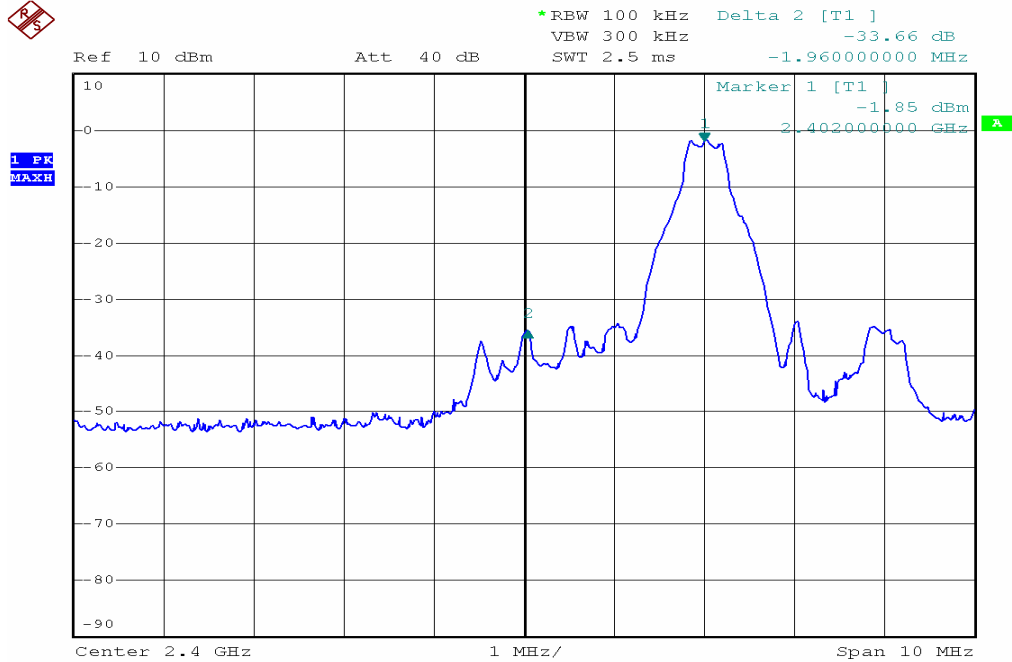

Date: 30.JAN.2007 16:27:47

2. For Highest Channel: the fundamental frequency is **2.480GHz.**

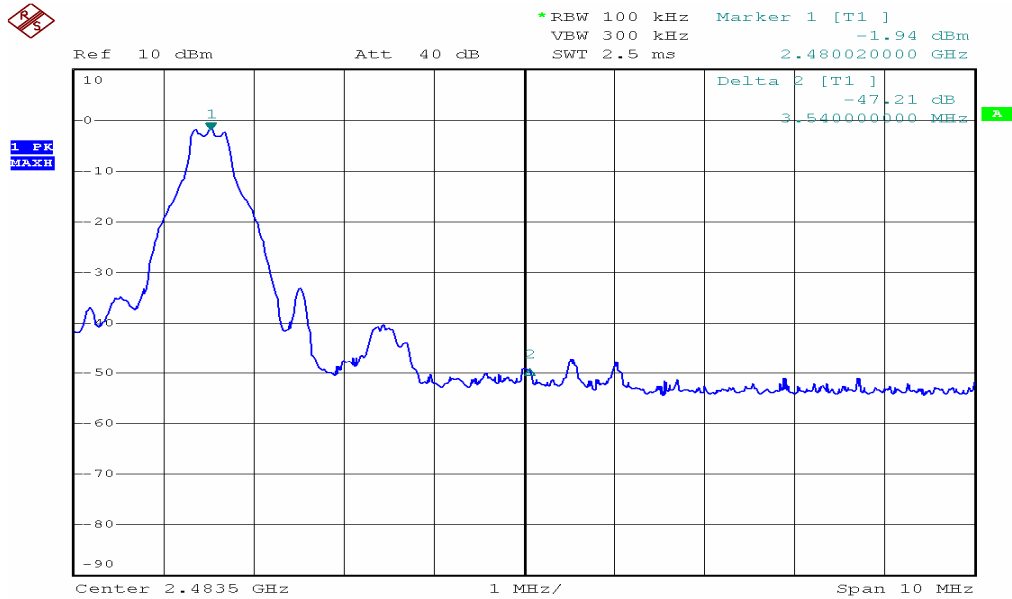

Date: 30.JAN.2007 16:29:15

6.6.2 Radiated Emissions which fall in the restricted bands

Test Requirement:	Section 15.247 (d) In addition, radiated emissions which fall in the restricted bands, as defined in Section 15.205(a), must also comply with the radiated emission limits specified in Section 15.209(a) (see Section 15.205(c)).
Test Method:	Base on ANSI 63.4.
Test Date:	30 January 2007
Measurement Distance:	3m (Semi-Anechoic Chamber)
Limit:	40.0 dB μ V/m between 30MHz & 88MHz 43.5 dB μ V/m between 88MHz & 216MHz 46.0 dB μ V/m between 216MHz & 960MHz 54.0 dB μ V/m above 960MHz
Detector:	Peak for pre-scan , 120kHz resolution bandwidth within 1GHz, 1MHz resolution bandwidth above 1GHz

Test Configuration:

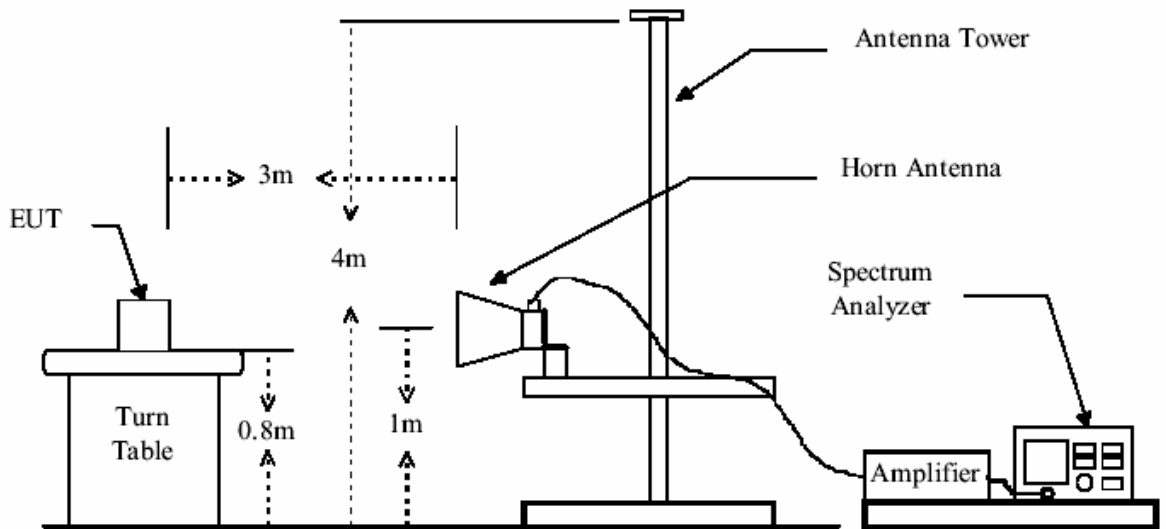



Test Procedure: The procedure used was ANSI Standard C63.4-2003. The receiver was scanned from 30MHz to 25GHz. When an emission was found, the table was rotated to produce the maximum signal strength. An initial pre-scan was performed for in peak detection mode using the receiver. The EUT was measured for both the Horizontal and Vertical polarities and performed a pre-test three orthogonal planes. For intentional radiators, measurements of the variation of the input power or the radiated signal level of the fundamental frequency component of the emission, as appropriate, shall be performed with the supply voltage varied between 85% and 115% of the nominal rated supply voltage. The worst case emissions were reported.

The field strength is calculated by adding the Antenna Factor, Cable Factor & Preamplifier. The basic equation with a sample calculation is as follows:

$$\text{Final Test Level} = \text{Receiver Reading} + \text{Antenna Factor} + \text{Cable Factor} - \text{Preamplifier Factor}$$

Test Result:

1. Channel 0 (2.402GHz)

Test Frequency (MHz)	Peak Level (dBuV/m)	Average Level (dBuV/m)	Peak Limit (dBuV/m)	Average Limit (dBuV/m)	Margin (dB)	
					Peak	AV
2390.000	45.5	35.2	74.0	54.0	28.5	18.8
2483.500	46.2	36.0	74.0	54.0	27.8	18.0

2. Channel 39 (2.441GHz)

Test Frequency (MHz)	Peak Level (dBuV/m)	Average Level (dBuV/m)	Peak Limit (dBuV/m)	Average Limit (dBuV/m)	Margin (dB)	
					Peak	AV
2390.000	44.8	36.0	74.0	54.0	29.2	18.0
2483.500	47.2	38.2	74.0	54.0	26.8	15.8

3. Channel 79 (2.480GHz)

Test Frequency (MHz)	Peak Level (dBuV/m)	Average Level (dBuV/m)	Peak Limit (dBuV/m)	Average Limit (dBuV/m)	Margin (dB)	
					Peak	AV
2390.000	45.0	35.9	74.0	54.0	29.0	18.1
2483.500	46.8	38.5	74.0	54.0	27.2	15.5

The unit does meet the FCC requirements.



Section 15.205 Restricted bands of operation.

(a) Except as shown in paragraph (d) of this section, only spurious emissions are permitted in any of the frequency bands listed below:

MHz	MHz	MHz	GHz
0.090 - 0.110	16.42 - 16.423	399.9 - 410	4.5 - 5.15
¹ 0.495 - 0.505	16.69475 - 16.69525	608 - 614	5.35 - 5.46
2.1735 - 2.1905	16.80425 - 16.80475	960 - 1240	7.25 - 7.75
4.125 - 4.128	25.5 - 25.67	1300 - 1427	8.025 - 8.5
4.17725 - 4.17775	37.5 - 38.25	1435 - 1626.5	9.0 - 9.2
4.20725 - 4.20775	73 - 74.6	1645.5 - 1646.5	9.3 - 9.5
6.215 - 6.218	74.8 - 75.2	1660 - 1710	10.6 - 12.7
6.26775 - 6.26825	108 - 121.94	1718.8 - 1722.2	13.25 - 13.4
6.31175 - 6.31225	123 - 138	2200 - 2300	14.47 - 14.5
8.291 - 8.294	149.9 - 150.05	2310 - 2390	15.35 - 16.2
8.362 - 8.366	156.52475 - 156.52525	2483.5 - 2500	17.7 - 21.4
8.37625 - 8.38675	156.7 - 156.9	2655 - 2900	22.01 - 23.12
8.41425 - 8.41475	162.0125 - 167.17	3260 - 3267	23.6 - 24.0
12.29 - 12.293	167.72 - 173.2	3332 - 3339	31.2 - 31.8
12.51975 - 12.52025	240 - 285	3345.8 - 3358	36.43 - 36.5
12.57675 - 12.57725	322 - 335.4	3600 - 4400	(²)
13.36 - 13.41			

6.7 Hopping Channel Number

Test Requirement: FCC Part15 C
 Test Method: Based on FCC Part15 C Section 15.247
 Test Date: 30 January 2007
 Requirements: Regulation 15.247 (a) (1)(iii) Frequency hopping systems in the 2400-2483.5 MHz band shall use at least 15 channels.

Test Procedure:

1. Remove the antenna from the EUT and then connect a low RF cable from the antenna port to the spectrum.
2. Set the spectrum analyzer: RBW = 100KHz, VBW = 100KHz, Sweep = auto; Detector Function = Peak.
3. Set the spectrum analyzer: start frequency = 2400MHz, stop frequency = 2483.5MHz. Record the max. hold reading graph.

Test result:

Total channels are 79 channels, channel 0 to channel 78.

It also comply with the demand of frequency hopping systems operating in the 2400-2483.5 MHz band employing at least 75 non-overlapping hopping channels. The Maximum peak conducted output power limit apply 1 watt according to regulation 15.247 (b)(1).

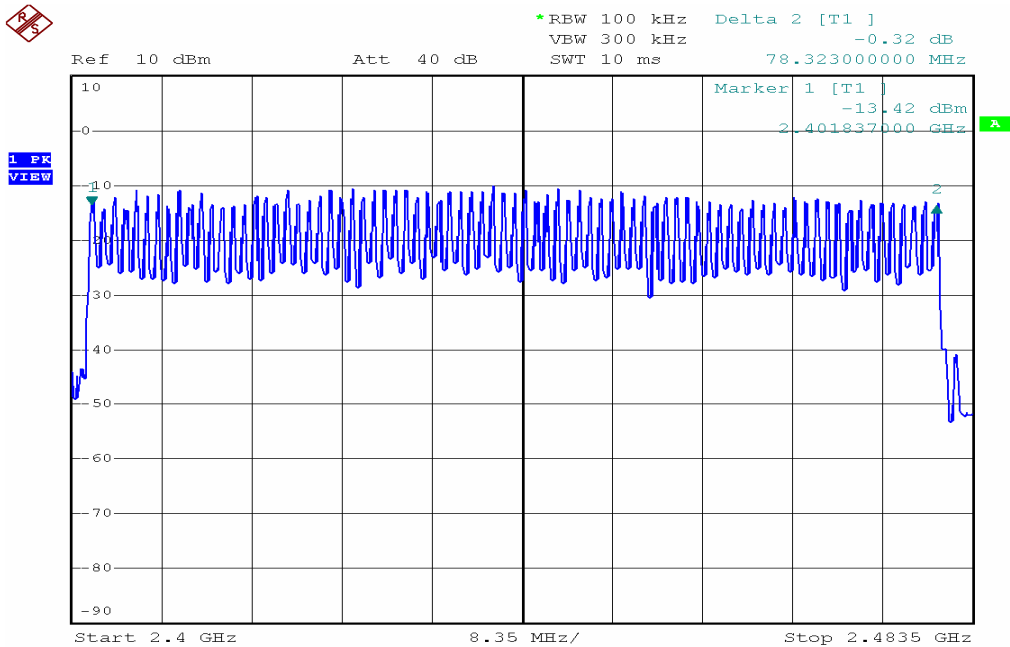

Date: 30.JAN.2007 17:06:55

6.8 Occupied Bandwidth

Test Requirement: FCC Part 15 C

Test Method: Based on FCC Part15 C Section 15.247:

Test Date: 30 January 2007

Test Procedure:

1. Remove the antenna from the EUT and then connect a low RF cable from the antenna port to the spectrum.
2. Set the spectrum analyzer: RBW \geq 1% of the 20dB bandwidth (set 10KHz), VBW \geq RBW (set 10KHz), Span = 3MHz, Sweep = auto; Detector Function = Peak (Max. hold).
3. Mark the peak frequency and -20dB points.

Test result:

Test Channel	20 dB bandwidth
0	600KHz
39	594KHz
78	600KHz

Please refer the graph as below: Lowest Channel (20 dB Bandwidth)

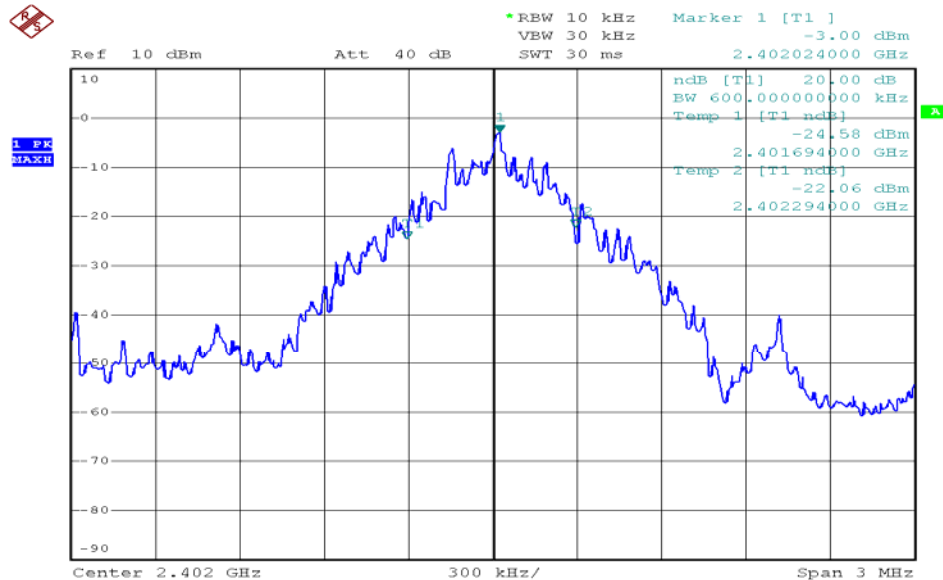

Date: 30.JAN.2007 16:22:59



Medium Channel (20 dB Bandwidth)

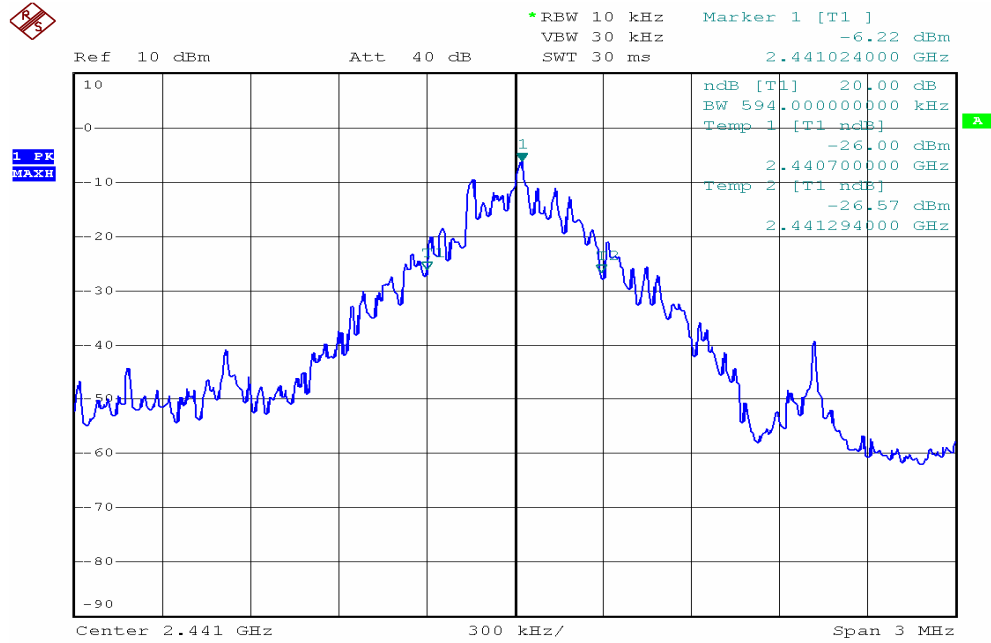

Date: 30.JAN.2007 16:32:15

Highest Channel (20 dB Bandwidth)

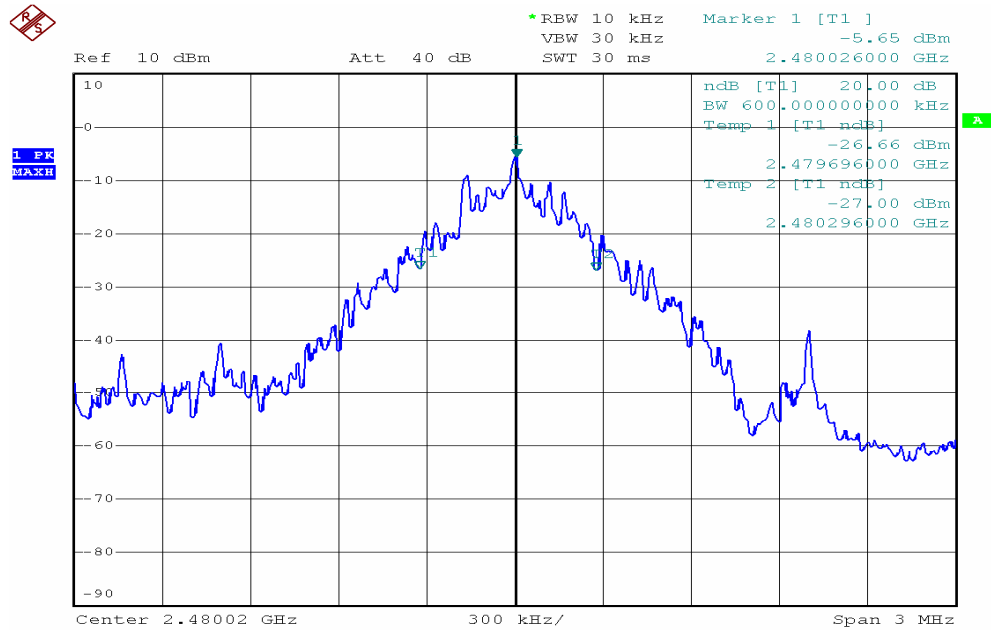

Date: 30.JAN.2007 16:30:49

6.9 Carrier Frequencies Separated

Test Requirement: FCC Part 15 C
 Test Method: Based on FCC Part15 C Section 15.247:
 Test Date: 30 January 2007
 Test requirements: Regulation 15.247(a)(1) Frequency hopping systems shall have hopping channel carrier frequencies separated by a minimum of 25 kHz or the 20 dB bandwidth of the hopping channel, whichever is greater. Alternatively, frequency hopping systems operating in the 2400-2483.5 MHz band may have hopping channel carrier frequencies that are separated by 25 kHz or two-thirds of the 20 dB bandwidth of the hopping channel, whichever is greater, provided the systems operate with an output power no greater than 125 mW.

Test Procedure:

1. Remove the antenna from the EUT and then connect a low RF cable from the antenna port to the spectrum.
2. Set the spectrum analyzer: RBW >= 1% of the span (set 100kHz), VBW >= RBW (set 300kHz), Span = 10MHz, Sweep = auto; Detector Function = Peak (Max. hold).
3. Mark the peak frequency and -20dB.

Test result:

Test Channel	Carrier Frequencies Separated	Limit	PASS/FAIL
Lower Channels (channel 0 and channel 1)	1.0MHz	600KHz (Base the result of Occupied Bandwidth)	Pass
Middle Channels (channel 39 and channel 40)	1.0MHz		Pass
Upper Channels (channel 77 and channel 78)	1.0MHz		Pass

1. Lower Channels: **Carrier Frequencies Separated**

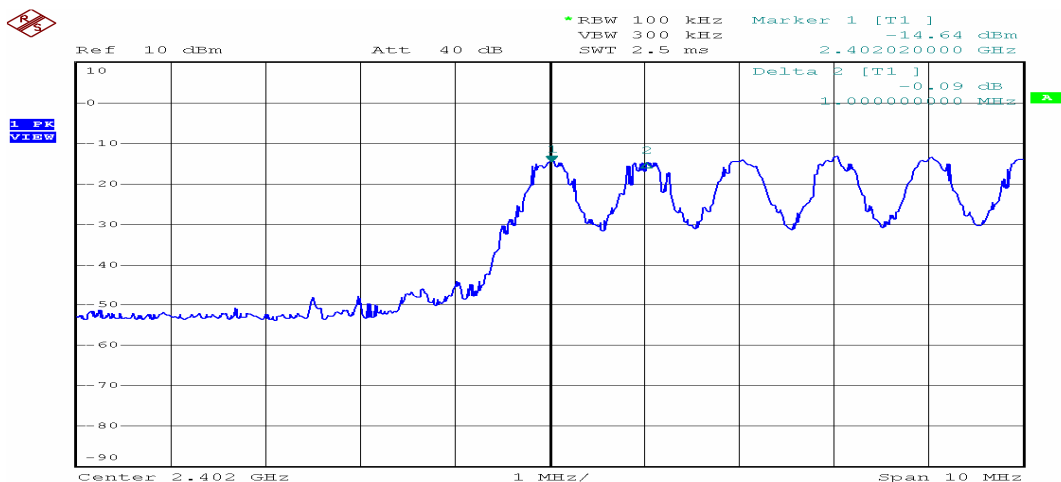

Date: 30.JAN.2007 17:12:14



2. Middle Channels: Carrier Frequencies Separated

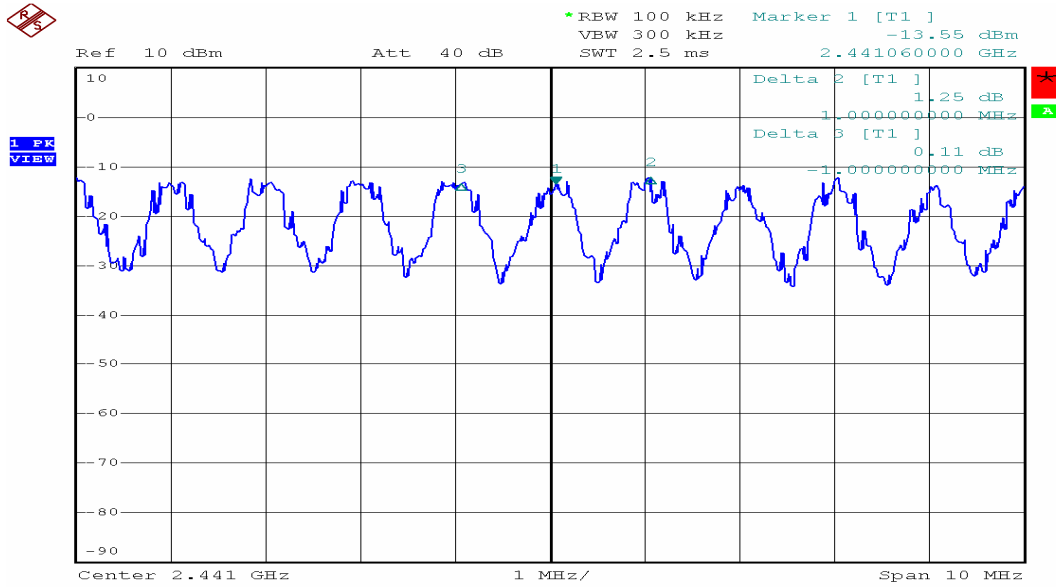

Date: 30.JAN.2007 17:14:55

3. Higher Channels: Carrier Frequencies Separated

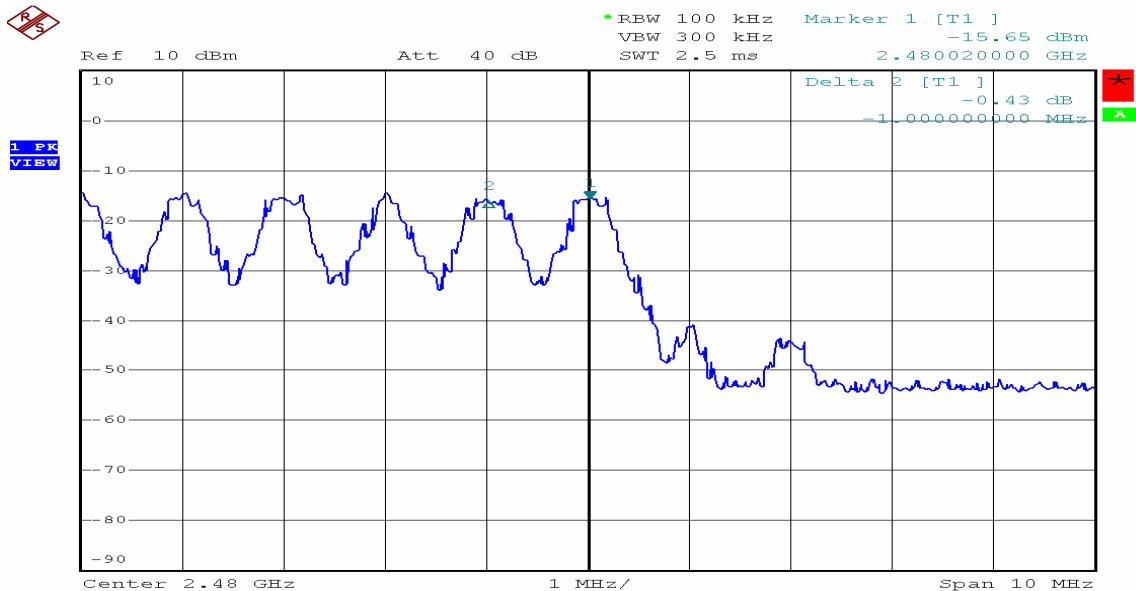

Date: 30.JAN.2007 17:17:08



6.10 Dwell Time

Test Requirement:	FCC Part 15 C
Test Method:	Based on FCC Part15 C Section 15.247:
Test Date:	30 January 2007
Test requirements:	Regulation 15.247(a)(1)(iii) Frequency hopping systems in the 2400-2483.5 MHz band shall use at least 15 channels. The average time of occupancy on any channel shall not be greater than 0.4 seconds within a period of 0.4 seconds multiplied by the number of hopping channels employed. Frequency hopping systems may avoid or suppress transmissions on a particular hopping frequency provided that a minimum of 15 channels are used.

Test Procedure:

1. Remove the antenna from the EUT and then connect a low RF cable from the antenna port to the spectrum.
2. Set RBW of spectrum analyzer to 1MHz and VBW of spectrum analyzer to 1MHz, Set the test channel frequency span to 0.

Test Result:

The test period: $T = 0.4 \text{ Second/Channel} \times 79 \text{ Channel} = 31.6 \text{ s}$

1. **Channel 0:** 2.402GHz

$$\text{DH1 time slot} = 0.415 \text{ (ms)} * (1600/(2*79)) * 31.6 = 132.800 \text{ ms}$$

$$\text{DH3 time slot} = 1.650 \text{ (ms)} * (1600/(4*79)) * 31.6 = 264.000 \text{ ms}$$

$$\text{DH5 time slot} = 2.875 \text{ (ms)} * (1600/(6*79)) * 31.6 = 306.667 \text{ ms}$$

2. **Channel 39:** 2.441GHz

$$\text{DH1 time slot} = 0.415 \text{ (ms)} * (1600/(2*79)) * 31.6 = 132.800 \text{ ms}$$

$$\text{DH3 time slot} = 1.675 \text{ (ms)} * (1600/(4*79)) * 31.6 = 268.000 \text{ ms}$$

$$\text{DH5 time slot} = 2.875 \text{ (ms)} * (1600/(6*79)) * 31.6 = 306.667 \text{ ms}$$

3. **Channel 78:** 2.4835GHz

$$\text{DH1 time slot} = 0.415 \text{ (ms)} * (1600/(2*79)) * 31.6 = 132.800 \text{ ms}$$

$$\text{DH3 time slot} = 1.675 \text{ (ms)} * (1600/(4*79)) * 31.6 = 268.000 \text{ ms}$$

$$\text{DH5 time slot} = 2.920 \text{ (ms)} * (1600/(6*79)) * 31.6 = 311.467\text{ms}$$

The results are not be greater than 0.4 seconds.

The unit does meet the FCC requirements.

Please refer the graph as below:



1. Lowest channel (2.402 GHz):

(1). DH1

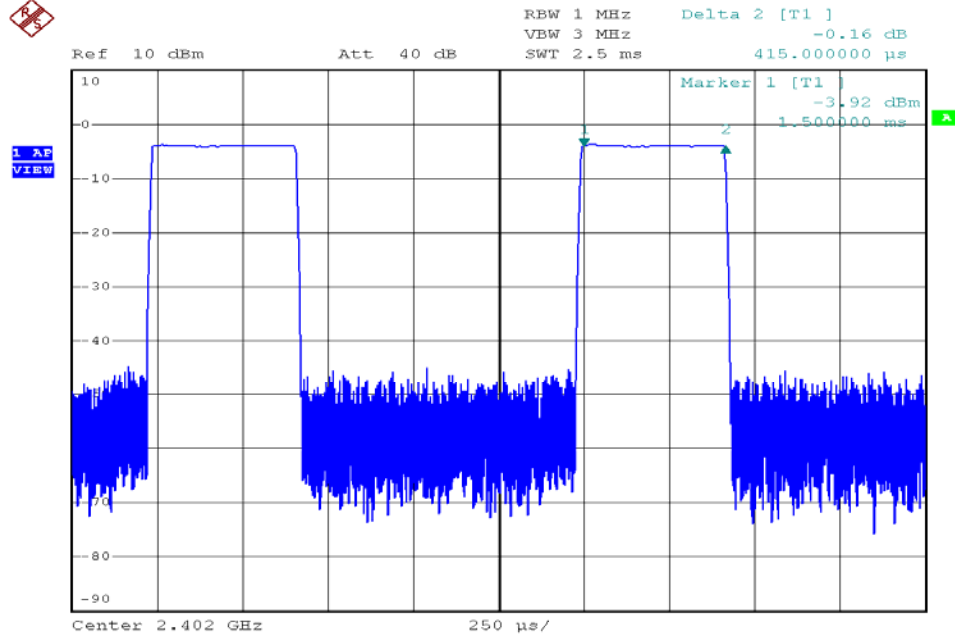

Date: 30.JAN.2007 15:51:20

(2) DH3:

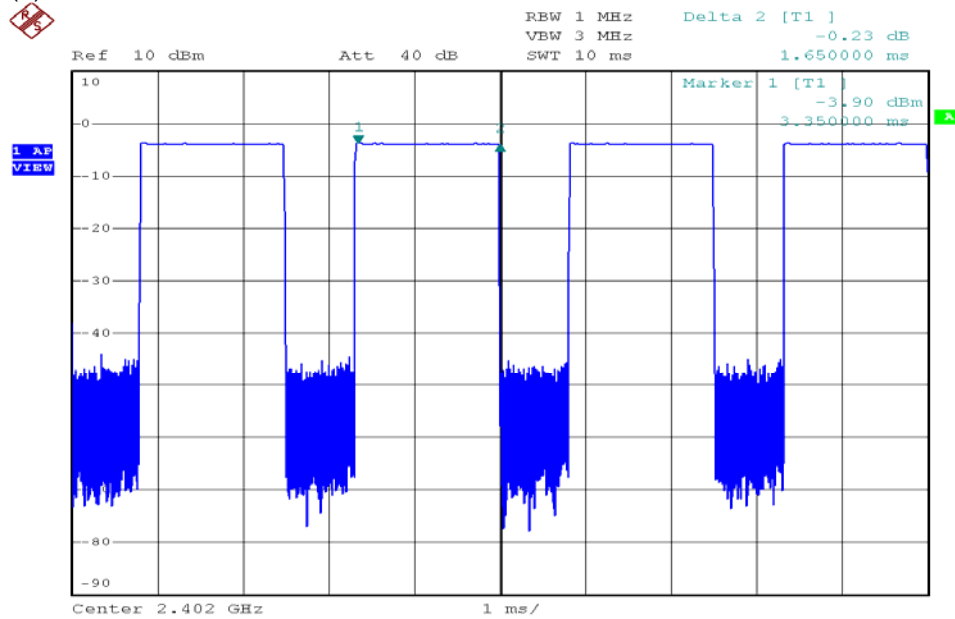

Date: 30.JAN.2007 15:50:23



1. Lowest channel (2.402 GHz):

(3). DH5:

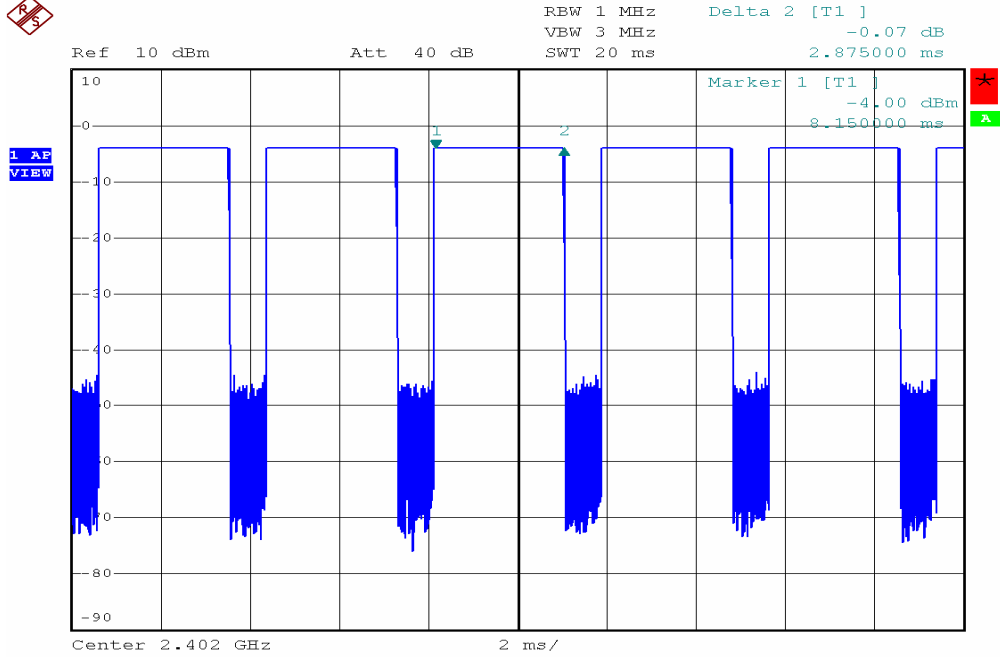

Date: 30.JAN.2007 15:49:11

2. Middle Channel (2.441GHz)

(1) DH1

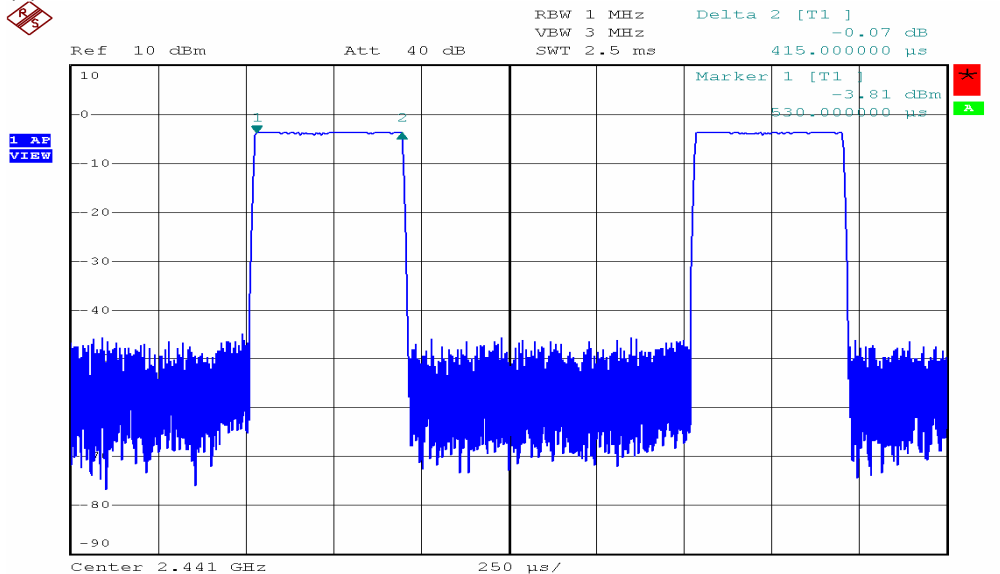

Date: 30.JAN.2007 15:45:13

2. Middle Channel (2.441GHz)

(2) DH3

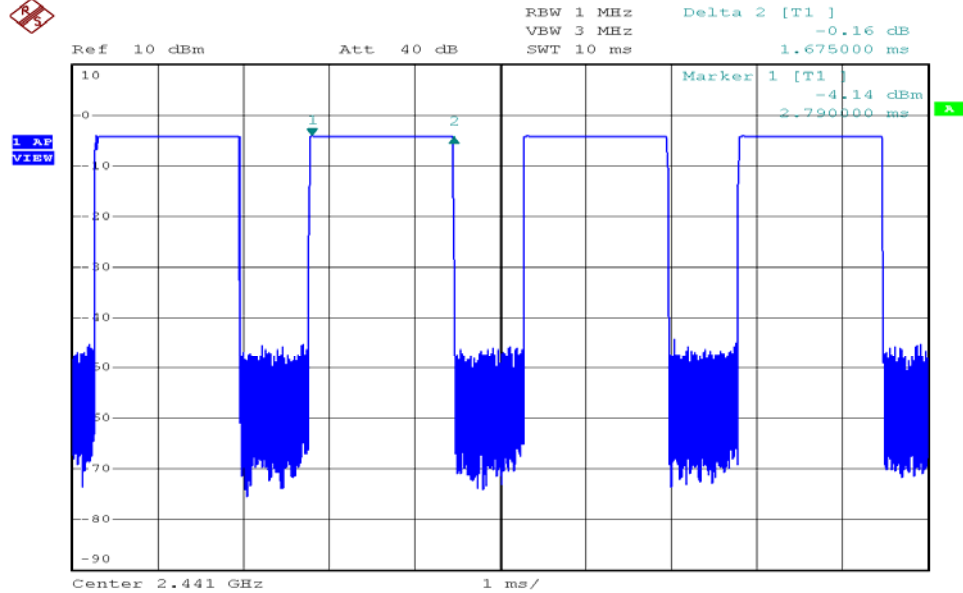

Date: 30.JAN.2007 15:46:41

(3) DH5

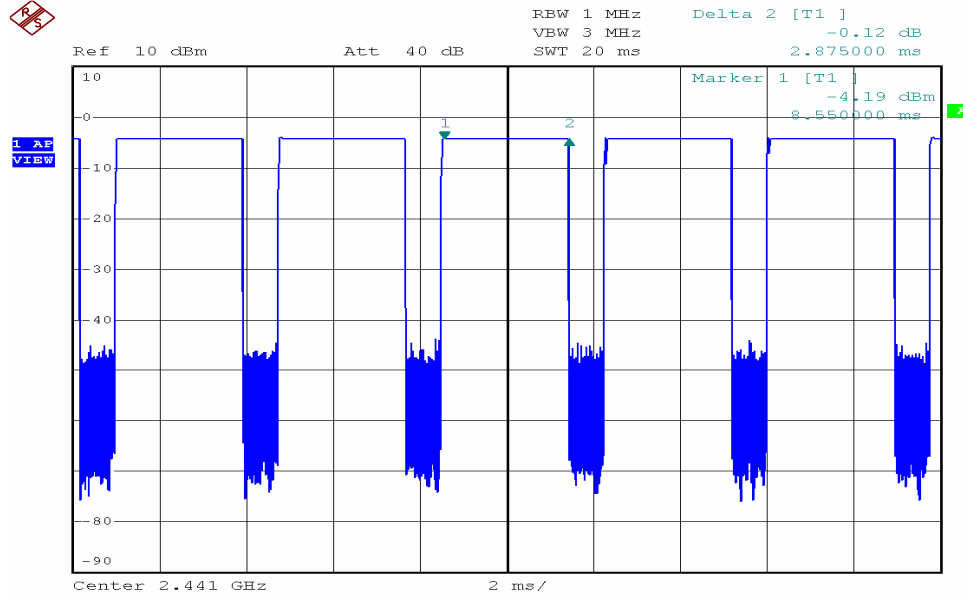

Date: 30.JAN.2007 15:48:09

3. Highest channel (2.480GHz)

(1). DH1

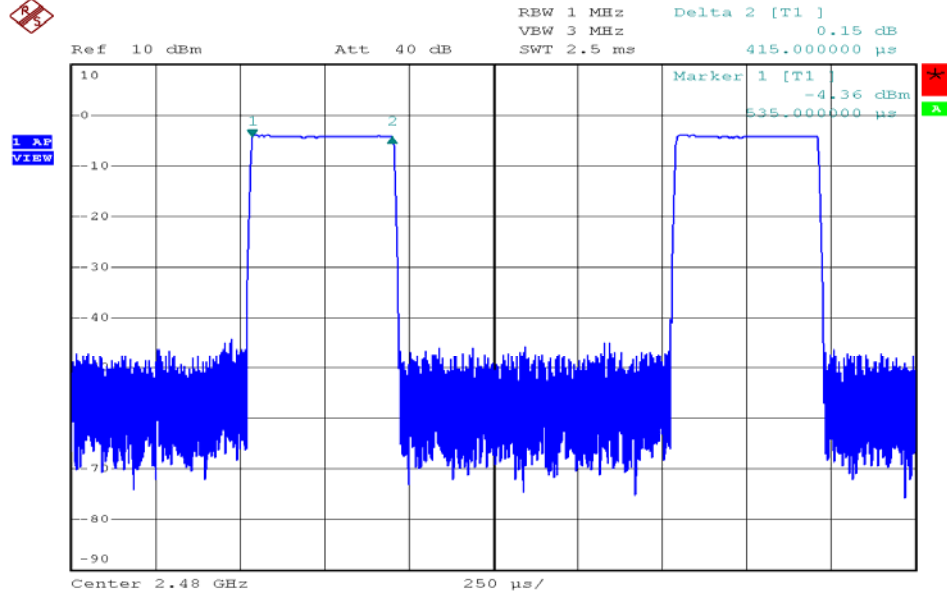

Date: 30.JAN.2007 15:52:30

(2). DH3

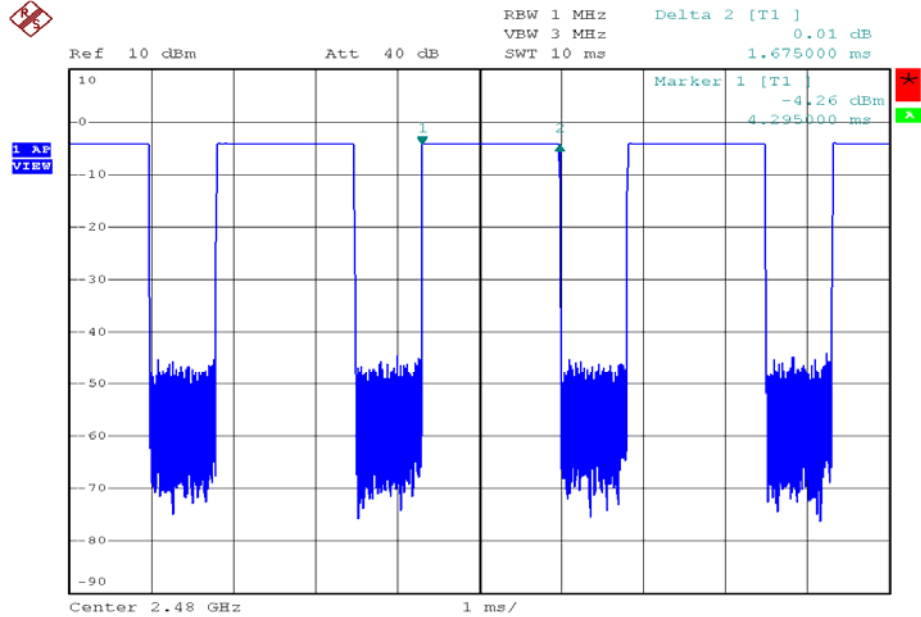

Date: 30.JAN.2007 15:53:30

3. Highest channel (2.480GHz)

(3). DH5

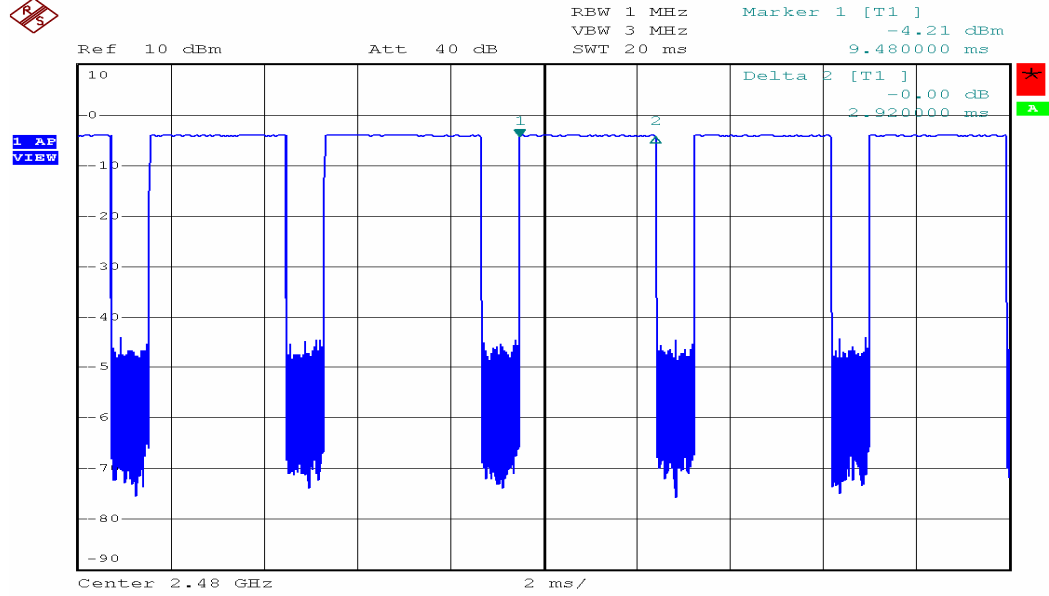

Date: 30.JAN.2007 15:55:58



6.11 Antenna Requirement

6.11.1 Standard Applicable

For intentional device, according to 15.203, an intentional radiator shall be designed to ensure that no antenna other than that furnished by the responsible party shall be used with the device.

Regulation 15.247(c) (1)(i) Systems operating in the 2400-2483.5 MHz band that are used exclusively for fixed, point-to-point operations may employ transmitting antennas with directional gain greater than 6 dBi provided the maximum conducted output power of the intentional radiator is reduced by 1 dB for every 3 dB that the directional gain of the antenna exceeds 6 dBi.

6.11.2 Antenna Construction

The antenna is integrated on the main PCB and no consideration of replacement.