



**DFS PORTION of FCC 47 CFR PART 15 SUBPART E
DFS PORTION of INDUSTRY CANADA RSS-247 ISSUE 1**

CERTIFICATION TEST REPORT

FOR

802.11ac ACCESS POINT

MODEL NUMBER: MR34-HW

**FCC ID: UDX-60025010
IC: 6961A-60025010**

REPORT NUMBER: 16U23159-E1V1

ISSUE DATE: APRIL 07, 2016

Prepared for
**CISCO SYSTEMS, INC.
170 WEST TASMAN DRIVE
SAN JOSE, CA, 95134, USA**

Prepared by
**UL VERIFICATION SERVICES INC.
47173 BENICIA STREET
FREMONT, CA 94538, U.S.A.
TEL: (510) 771-1000
FAX: (510) 661-0888**



NVLAP LAB CODE 200065-0

Revision History

<u>Rev.</u>	<u>Issue Date</u>	<u>Revisions</u>	<u>Revised By</u>
V1	04/07/16	Initial Issue	Conan Cheung

TABLE OF CONTENTS

1. ATTESTATION OF TEST RESULTS	4
2. TEST METHODOLOGY	5
3. FACILITIES AND ACCREDITATION	5
4. CALIBRATION AND UNCERTAINTY	5
4.1. <i>MEASURING INSTRUMENT CALIBRATION</i>	<i>5</i>
4.2. <i>SAMPLE CALCULATION</i>	<i>5</i>
4.3. <i>MEASUREMENT UNCERTAINTY</i>	<i>5</i>
5. DYNAMIC FREQUENCY SELECTION.....	6
5.1. <i>OVERVIEW</i>	<i>6</i>
5.1.1. <i>LIMITS.....</i>	<i>6</i>
5.1.2. <i>TEST AND MEASUREMENT SYSTEM.....</i>	<i>10</i>
5.1.3. <i>SETUP OF EUT.....</i>	<i>13</i>
5.1.4. <i>DESCRIPTION OF EUT</i>	<i>14</i>
5.2. <i>RESULTS FOR 20 MHz BANDWIDTH.....</i>	<i>15</i>
5.2.1. <i>TEST CHANNEL</i>	<i>15</i>
5.2.2. <i>RADAR WAVEFORMS AND TRAFFIC.....</i>	<i>15</i>
5.2.3. <i>CHANNEL AVAILABILITY CHECK TIME.....</i>	<i>24</i>
5.2.4. <i>OVERLAPPING CHANNEL TESTS.....</i>	<i>29</i>
5.2.5. <i>MOVE AND CLOSING TIME</i>	<i>29</i>
5.2.6. <i>DETECTION BANDWIDTH.....</i>	<i>34</i>
5.2.7. <i>IN-SERVICE MONITORING</i>	<i>36</i>
5.3. <i>RESULTS FOR 40 MHz BANDWIDTH.....</i>	<i>43</i>
5.3.1. <i>TEST CHANNEL</i>	<i>43</i>
5.3.2. <i>RADAR WAVEFORMS AND TRAFFIC.....</i>	<i>43</i>
5.3.3. <i>CHANNEL AVAILABILITY CHECK TIME.....</i>	<i>52</i>
5.3.1. <i>OVERLAPPING CHANNEL TESTS.....</i>	<i>57</i>
5.3.2. <i>MOVE AND CLOSING TIME</i>	<i>57</i>
5.3.1. <i>NON-OCCUPANCY PERIOD</i>	<i>62</i>
5.3.2. <i>DETECTION BANDWIDTH.....</i>	<i>63</i>
5.3.3. <i>IN-SERVICE MONITORING</i>	<i>65</i>
5.4. <i>RESULTS FOR 80 MHz BANDWIDTH.....</i>	<i>72</i>
5.4.1. <i>TEST CHANNEL</i>	<i>72</i>
5.4.2. <i>RADAR WAVEFORMS AND TRAFFIC.....</i>	<i>72</i>
5.4.1. <i>CHANNEL AVAILABILITY CHECK TIME.....</i>	<i>81</i>
5.4.2. <i>OVERLAPPING CHANNEL TESTS.....</i>	<i>86</i>
5.4.3. <i>MOVE AND CLOSING TIME</i>	<i>86</i>
5.4.1. <i>NON-OCCUPANCY PERIOD</i>	<i>91</i>
5.4.2. <i>DETECTION BANDWIDTH.....</i>	<i>92</i>
5.4.3. <i>IN-SERVICE MONITORING</i>	<i>94</i>
6. BRIDGE MODE RESULTS.....	103
7. SETUP PHOTOS.....	104

ATTESTATION OF TEST RESULTS

COMPANY NAME: CISCO SYSTEMS, INC.
170 WEST TASMAN DRIVE
SAN JOSE, CA, 95134, USA

EUT DESCRIPTION: 802.11ac ACCESS POINT

MODEL: MR34-HW

SERIAL NUMBER: Q2FD-SBWQ-PXVF

DATE TESTED: MARCH 22, 2016 – APRIL 6, 2016

APPLICABLE STANDARDS	
STANDARD	TEST RESULTS
DFS Portion of CFR 47 Part 15 Subpart E	Pass
INDUSTRY CANADA RSS-247 Issue 1	Pass

UL Verification Services Inc. tested the above equipment in accordance with the requirements set forth in the above standards. All indications of Pass/Fail in this report are opinions expressed by UL Verification Services Inc. based on interpretations and/or observations of test results. Measurement Uncertainties were not taken into account and are published for informational purposes only. The test results show that the equipment tested is capable of demonstrating compliance with the requirements as documented in this report.

Note: The results documented in this report apply only to the tested sample, under the conditions and modes of operation as described herein. This document may not be altered or revised in any way unless done so by UL Verification Services Inc. and all revisions are duly noted in the revisions section. Any alteration of this document not carried out by UL Verification Services Inc. will constitute fraud and shall nullify the document. This report must not be used by the client to claim product certification, approval, or endorsement by NVLAP, NIST, any agency of the Federal Government, or any agency of any government.

Approved & Released For
UL Verification Services Inc. By:

Tested By:



CONAN CHEUNG
PROJECT LEAD
UL Verification Services Inc.

HENRY LAU
EMC ENGINEER
UL Verification Services Inc.

1. TEST METHODOLOGY

The tests documented in this report were performed in accordance with the DFS portion of FCC CFR 47 Part 2, FCC CFR 47 Part 15, FCC 06-96, FCC KDB 789033, KDB 905462 D02 and D03, ANSI C63.10-2013, RSS-247 Issue 1.

2. FACILITIES AND ACCREDITATION

The test sites and measurement facilities used to collect data are located at 47173 Benicia Street, Fremont, California, USA.

UL Verification Services, Inc. is accredited by NVLAP, Laboratory Code 200065-0. The full scope of accreditation can be viewed at <http://ts.nist.gov/standards/scopes/2000650.htm>.

3. CALIBRATION AND UNCERTAINTY

3.1. MEASURING INSTRUMENT CALIBRATION

The measuring equipment utilized to perform the tests documented in this report has been calibrated in accordance with the manufacturer's recommendations, and is traceable to recognized national standards.

3.2. SAMPLE CALCULATION

Where relevant, the following sample calculation is provided:

$$\begin{aligned} \text{Field Strength (dBuV/m)} &= \text{Measured Voltage (dBuV)} + \text{Antenna Factor (dB/m)} + \\ &\text{Cable Loss (dB)} - \text{Preamp Gain (dB)} \\ 36.5 \text{ dBuV} + 18.7 \text{ dB/m} + 0.6 \text{ dB} - 26.9 \text{ dB} &= 28.9 \text{ dBuV/m} \end{aligned}$$

3.3. MEASUREMENT UNCERTAINTY

Where relevant, the following measurement uncertainty levels have been estimated for tests performed on the apparatus:

PARAMETER	UNCERTAINTY
Conducted Disturbance, 0.15 to 30 MHz	± 3.52 dB
Radiated Disturbance, 30 to 1000 MHz	± 4.94 dB
Radiated Disturbance, 1 to 6 GHz	± 3.86 dB
Radiated Disturbance, 6 to 18 GHz	± 4.23 dB
Radiated Disturbance, 18 to 26 GHz	± 5.30 dB
Radiated Disturbance, 26 to 40 GHz	± 5.23 dB

Uncertainty figures are valid to a confidence level of 95%.

4. DYNAMIC FREQUENCY SELECTION

4.1. OVERVIEW

4.1.1. LIMITS

INDUSTRY CANADA

IC RSS-247 is closely harmonized with FCC Part 15 DFS rules. The deviations are as follows:

RSS-247 Issue 1

Note: For the band 5600–5650 MHz, no operation is permitted.

Until further notice, devices subject to this annex shall not be capable of transmitting in the band 5600–5650 MHz. This restriction is for the protection of Environment Canada weather radars operating in this band.

FCC

§15.407 (h), FCC KDB 905462 D02 “COMPLIANCE MEASUREMENT PROCEDURES FOR UNLICENSED-NATIONAL INFORMATION INFRASTRUCTURE DEVICES OPERATING IN THE 5250-5350 MHz AND 5470-5725 MHz BANDS INCORPORATING DYNAMIC FREQUENCY SELECTION” and KDB 905462 D03 “U-NII CLIENT DEVICES WITHOUT RADAR DETECTION CAPABILITY”.

Table 1: Applicability of DFS requirements prior to use of a channel

Requirement	Operational Mode		
	Master	Client (without radar detection)	Client (with radar detection)
Non-Occupancy Period	Yes	Not required	Yes
DFS Detection Threshold	Yes	Not required	Yes
Channel Availability Check Time	Yes	Not required	Not required
U-NII Detection Bandwidth	Yes	Not required	Yes

Table 2: Applicability of DFS requirements during normal operation

Requirement	Operational Mode		
	Master	Client (without DFS)	Client (with DFS)
DFS Detection Threshold	Yes	Not required	Yes
Channel Closing Transmission Time	Yes	Yes	Yes
Channel Move Time	Yes	Yes	Yes
U-NII Detection Bandwidth	Yes	Not required	Yes

Additional requirements for devices with multiple bandwidth modes	Master Device or Client with Radar DFS	Client (without DFS)
<i>U-NII Detection Bandwidth and Statistical Performance Check</i>	All BW modes must be tested	Not required
<i>Channel Move Time and Channel Closing Transmission Time</i>	Test using widest BW mode available	Test using the widest BW mode available for the link
<i>All other tests</i>	Any single BW mode	Not required
Note: Frequencies selected for statistical performance check (Section 7.8.4) should include several frequencies within the radar detection bandwidth and frequencies near the edge of the radar detection bandwidth. For 802.11 devices it is suggested to select frequencies in all 20 MHz channel blocks and a null frequency between the bonded 20 MHz channel blocks.		

Table 3: Interference Threshold values, Master or Client incorporating In-Service Monitoring

Maximum Transmit Power	Value (see notes)
E.I.R.P. \geq 200 mill watt	-64 dBm
E.I.R.P. < 200 mill watt and power spectral density < 10 dBm/MHz	-62 dBm
E.I.R.P. < 200 mill watt that do not meet power spectral density requirement	-64 dBm
<p>Note 1: This is the level at the input of the receiver assuming a 0 dBi receive antenna Note 2: Throughout these test procedures an additional 1 dB has been added to the amplitude of the test transmission waveforms to account for variations in measurement equipment. This will ensure that the test signal is at or above the detection threshold level to trigger a DFS response. Note 3: E.I.R.P. is based on the highest antenna gain. For MIMO devices refer to KDB publication 662911 D01.</p>	

Table 4: DFS Response requirement values

Parameter	Value
<i>Non-occupancy period</i>	30 minutes
<i>Channel Availability Check Time</i>	60 seconds
<i>Channel Move Time</i>	10 seconds (See Note 1)
<i>Channel Closing Transmission Time</i>	200 milliseconds + approx. 60 milliseconds over remaining 10 second period. (See Notes 1 and 2)
<i>U-NII Detection Bandwidth</i>	Minimum 100% of the U-NII 99% transmission power bandwidth. (See Note 3)
<p>Note 1: <i>Channel Move Time</i> and the <i>Channel Closing Transmission Time</i> should be performed with Radar Type 0. The measurement timing begins at the end of the Radar Type 0 burst. Note 2: The <i>Channel Closing Transmission Time</i> is comprised of 200 milliseconds starting at the beginning of the <i>Channel Move Time</i> plus any additional intermittent control signals required to facilitate a <i>Channel</i> move (an aggregate of 60 milliseconds) during the remainder of the 10 second period. The aggregate duration of control signals will not count quiet periods in between transmissions. Note 3: During the <i>U-NII Detection Bandwidth</i> detection test, radar type 0 should be used. For each frequency step the minimum percentage of detection is 90 percent. Measurements are performed with no data traffic.</p>	

Table 5 – Short Pulse Radar Test Waveforms

Radar Type	Pulse Width (usec)	PRI (usec)	Pulses	Minimum Percentage of Successful Detection	Minimum Trials
0	1	1428	18	See Note 1	See Note 1
1	1	Test A: 15 unique PRI values randomly selected from the list of 23 PRI values in table 5a	Roundup: $\{(1/360) \times (19 \times 10^6 \text{ PRI}_{\text{usec}})\}$	60%	30
		Test B: 15 unique PRI values randomly selected within the range of 518-3066 usec. With a minimum increment of 1 usec, excluding PRI values selected in Test A			
2	1-5	150-230	23-29	60%	30
3	6-10	200-500	16-18	60%	30
4	11-20	200-500	12-16	60%	30
Aggregate (Radar Types 1-4)				80%	120
Note 1: Short Pulse Radar Type 0 should be used for the <i>Detection Bandwidth</i> test, <i>Channel Move Time</i> , and <i>Channel Closing Time</i> tests.					

Table 6 – Long Pulse Radar Test Signal

Radar Waveform Type	Pulse Width (µsec)	Chirp Width (MHz)	PRI (µsec)	Pulses per Burst	Number of Bursts	Minimum Percentage of Successful Detection	Minimum Trials
5	50-100	5-20	1000-2000	1-3	8-20	80%	30

Table 7 – Frequency Hopping Radar Test Signal

Radar Waveform Type	Pulse Width (µsec)	PRI (µsec)	Pulses per Hop	Hopping Rate (kHz)	Hopping Sequence Length (msec)	Minimum Percentage of Successful Detection	Minimum Trials
6	1	333	9	0.333	300	70%	30

4.1.2. TEST AND MEASUREMENT SYSTEM

RADIATED METHOD SYSTEM BLOCK DIAGRAM

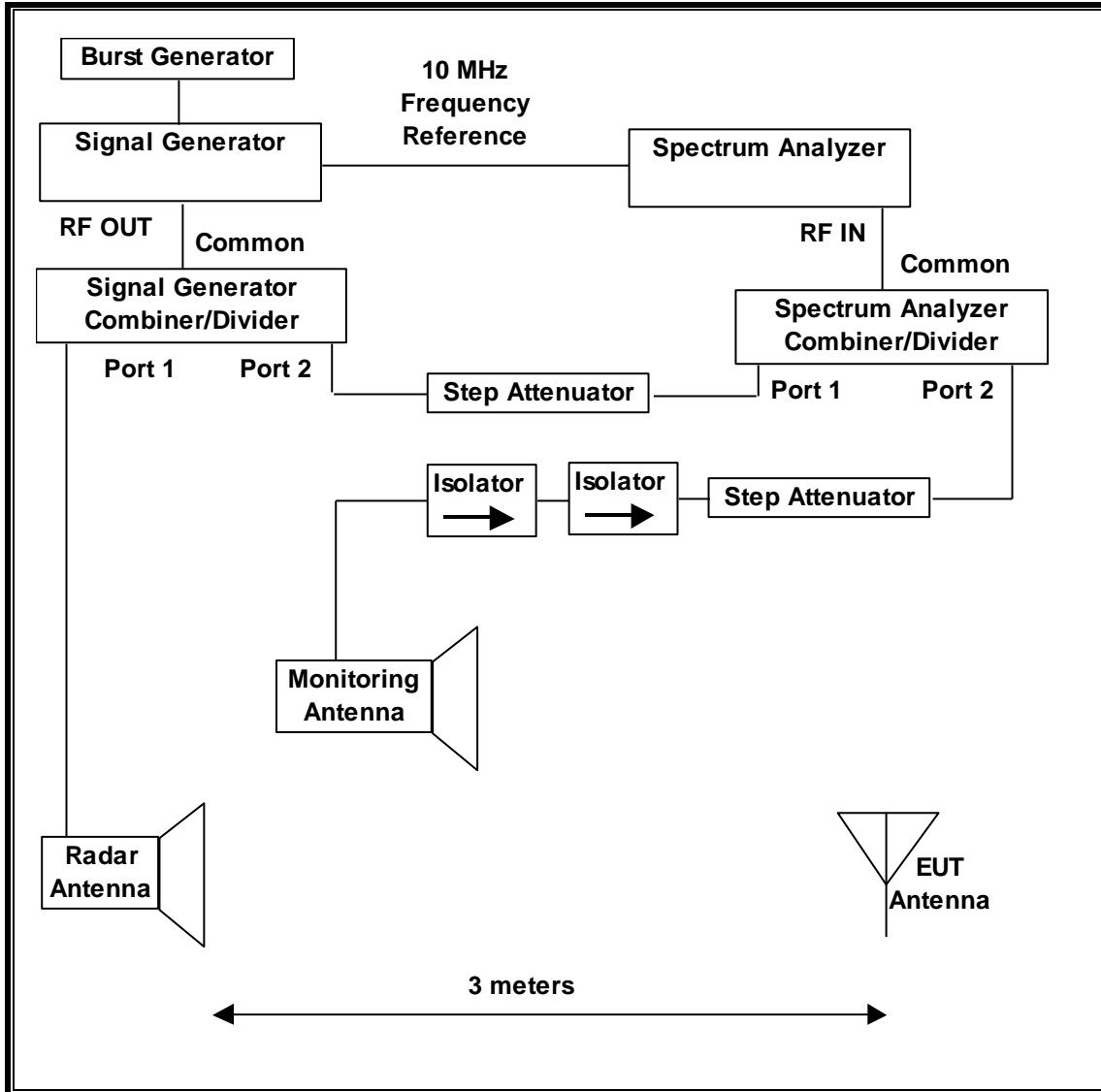

SYSTEM OVERVIEW

The short pulse and long pulse signal generating system utilizes the NTIA software. The Vector Signal Generator has been validated by the NTIA. The hopping signal generating system utilizes the CCS simulated hopping method and system, which has been validated by the DoD, FCC and NTIA. The software selects waveform parameters from within the bounds of the signal type on a random basis using uniform distribution.

The short pulse types 1, 2, 3 and 4, and the long pulse type 5 parameters are randomized at run-time.

The hopping type 6 pulse parameters are fixed while the hopping sequence is based on the August 2005 NTIA Hopping Frequency List. The initial starting point randomized at run-time and each subsequent starting point is incremented by 475. Each frequency in the 100-length segment is compared to the boundaries of the EUT Detection Bandwidth and the software creates a hopping burst pattern in accordance with Section 7.4.1.3 Method #2 Simulated Frequency Hopping Radar Waveform Generating Subsystem of KDB 905462 D02. The frequency of the signal generator is incremented in 1 MHz steps from F_L to F_H for each successive trial. This incremental sequence is repeated as required to generate a minimum of 30 total trials and to maintain a uniform frequency distribution over the entire Detection Bandwidth.

The signal monitoring equipment consists of a spectrum analyzer. The aggregate ON time is calculated by multiplying the number of bins above a threshold during a particular observation period by the dwell time per bin, with the analyzer set to peak detection and max hold.

SYSTEM CALIBRATION

A 50-ohm load is connected in place of the spectrum analyzer, and the spectrum analyzer is connected to a horn antenna via a coaxial cable, with the reference level offset set to (horn antenna gain – coaxial cable loss). The signal generator is set to CW mode. The amplitude of the signal generator is adjusted to yield a level of –64 dBm as measured on the spectrum analyzer.

Without changing any of the instrument settings, the spectrum analyzer is reconnected to the Common port of the Spectrum Analyzer Combiner/Divider. The Reference Level Offset of the spectrum analyzer is adjusted so that the displayed amplitude of the signal is –64 dBm.

The spectrum analyzer displays the level of the signal generator as received at the antenna ports of the Master Device. The interference detection threshold may be varied from the calibrated value of –64 dBm and the spectrum analyzer will still indicate the level as received by the Master Device.

ADJUSTMENT OF DISPLAYED TRAFFIC LEVEL

A link is established between the Master and Slave and the distance between the units is adjusted as needed to provide a suitable received level at the Master and Slave devices. The video test file is streamed to generate WLAN traffic. The monitoring antenna is adjusted so that the WLAN traffic level, as displayed on the spectrum analyzer, is at lower amplitude than the radar detection threshold.

TEST AND MEASUREMENT EQUIPMENT

The following test and measurement equipment was utilized for the DFS tests documented in this report:

TEST EQUIPMENT LIST				
Description	Manufacturer	Model	Serial Number	Cal Due
Spectrum Analyzer, PXA, 3Hz to 44GHz	Keysight	N9030A	US51350187	06/01/16
Signal Generator, MXG X-Series RF Vector	Agilent	N5172B	MY51350337	03/11/17
Arbitrary Waveform Generator	Agilent / HP	33220A	MY44037572	04/08/16

4.1.3. SETUP OF EUT

RADIATED METHOD EUT TEST SETUP

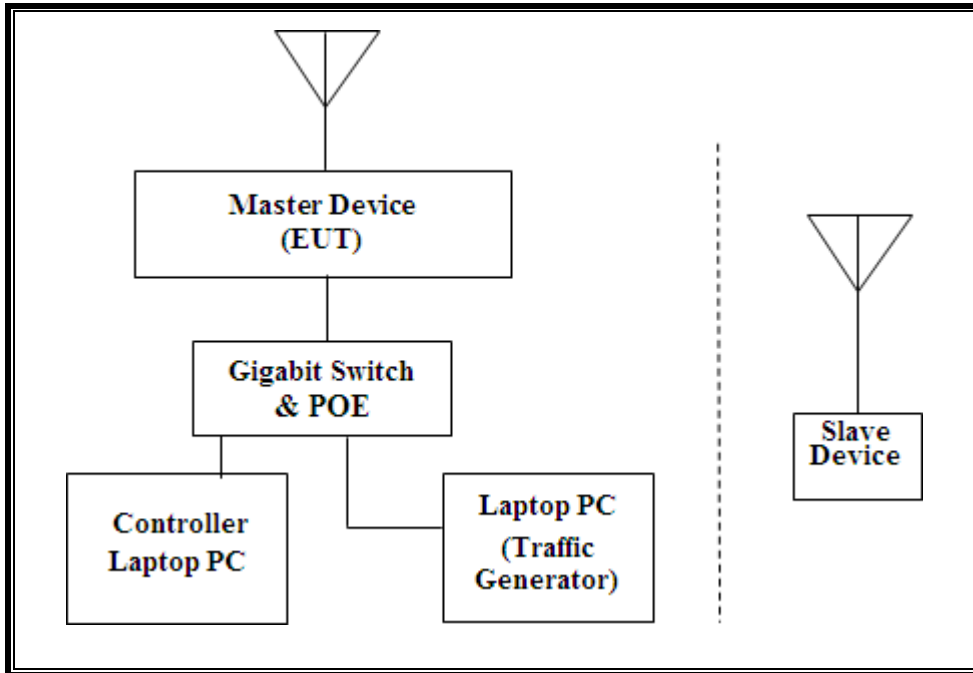

SUPPORT EQUIPMENT

The following support equipment was utilized for the DFS tests documented in this report:

PERIPHERAL SUPPORT EQUIPMENT LIST				
Description	Manufacturer	Model	Serial Number	FCC ID
Laptop PC (Controller)	Apple	A1502	C02NT1VTG3QR	QDS-BRCM1069
AC Adapter (Controller)	Apple	A1435	D39433601B4FTC0A1	DoC
Gigabit Switch	Meraki	MS220-8P	Q2HP-DR3G-TQZS	DoC
Laptop PC (Slave Device)	Apple	A1465	C02KTGMPF5N7	QDS-BRCM1072
AC Adapter (Slave Device)	Apple	A1435	C04341216J2F288BT	DoC
Laptop PC (Traffic Generator)	Lenovo	TYPE 4287-5TU	R9-PLM9D 12/06	QDS-BRCM1046
AC Adapter (Traffic Generator)	Lenovo	45N0121	11S45N0121Z1ZH XU213D MG	DoC

4.1.4. DESCRIPTION OF EUT

The EUT operates over the 5250-5350 MHz and 5470-5725 MHz ranges, excluding the 5600-5650 MHz range.

The EUT is a Master Device.

The highest power level within these bands is 28.2 dBm EIRP in the 5250-5350 MHz band and 26.8 dBm EIRP in the 5470-5725 MHz band.

The antenna assembly utilized with the EUT has a gain of 5.6, 5.5, and 5.2 dBi.

Three identical antennas are utilized to meet the diversity and MIMO operational requirements.

The rated output power of the Master unit is > 23dBm (EIRP). Therefore the required interference threshold level is -64 dBm. After correction for procedural adjustments, the required radiated threshold at the antenna port is $-64 + 1 = -63$ dBm.

The calibrated radiated DFS Detection Threshold level is set to -64 dBm. The tested level is lower than the required level hence it provides a margin to the limit.

The EUT uses three transmitter/receiver chains, each connected to an antenna to perform radiated tests.

The Slave device associated with the EUT during these tests does not have radar detection capability.

WLAN traffic that meets or exceeds the minimum required loading was generated by transferring a data stream from the Master Device to the Slave Device using iPerf version 2.0.5 software package.

TPC is required since the maximum EIRP is greater than 500 mW (27 dBm).

The EUT utilizes the 802.11ac architecture. Three nominal channel bandwidths are implemented: 20 MHz, 40 MHz and 80 MHz.

The software installed in the EUT is firmware_topaz_powerpc_version 22-133503.

UNIFORM CHANNEL SPREADING

This function is not required per KDB 905462.

4.2. RESULTS FOR 20 MHz BANDWIDTH

4.2.1. TEST CHANNEL

All tests were performed at a channel center frequency of 5500 MHz.

4.2.2. RADAR WAVEFORMS AND TRAFFIC

RADAR WAVEFORMS

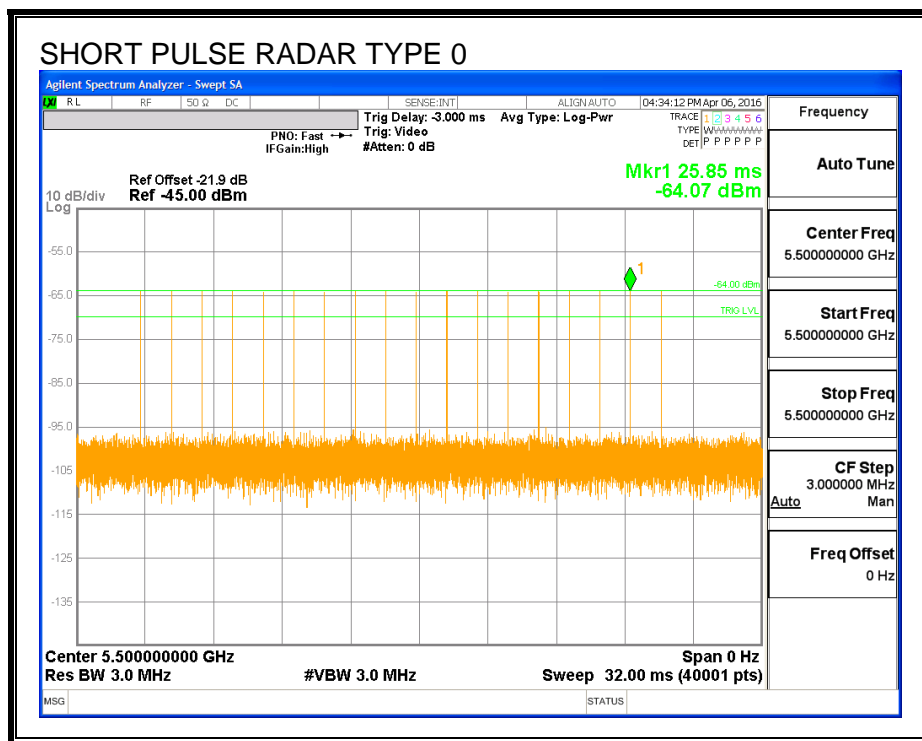

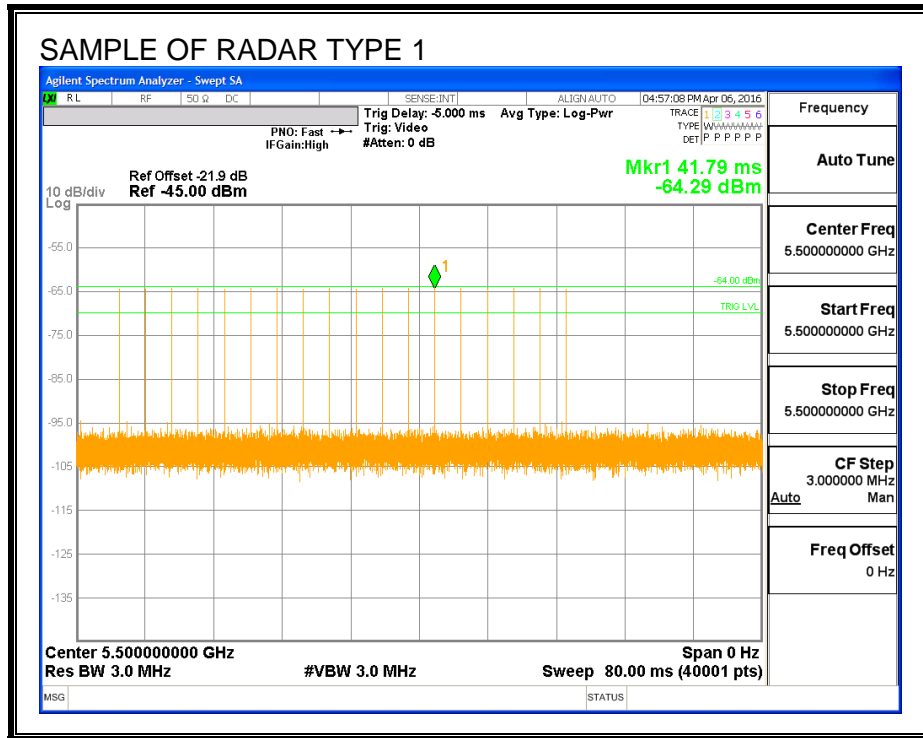

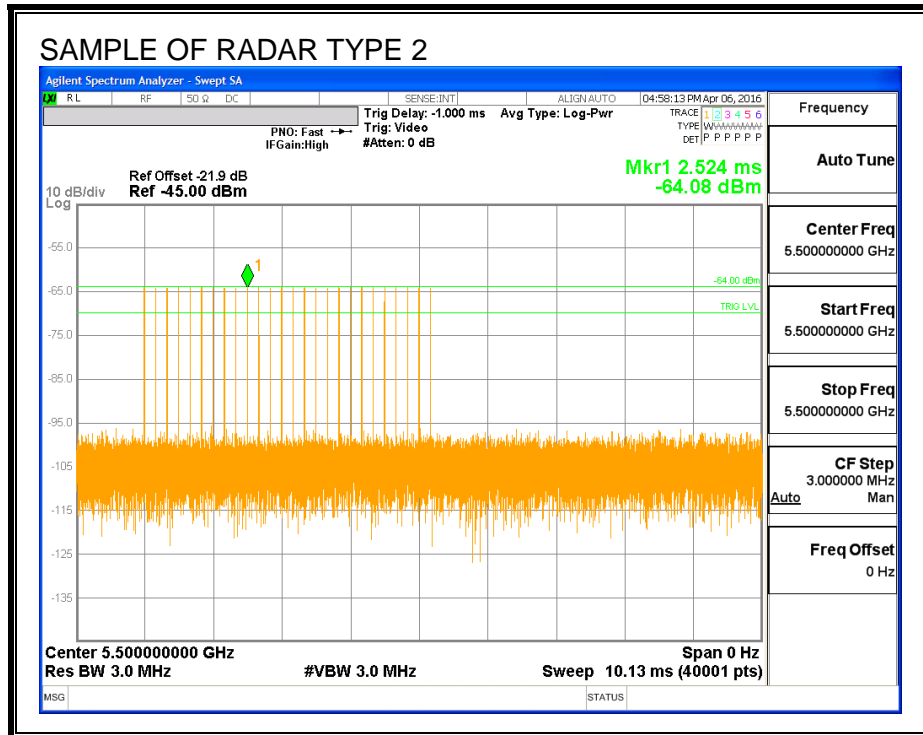

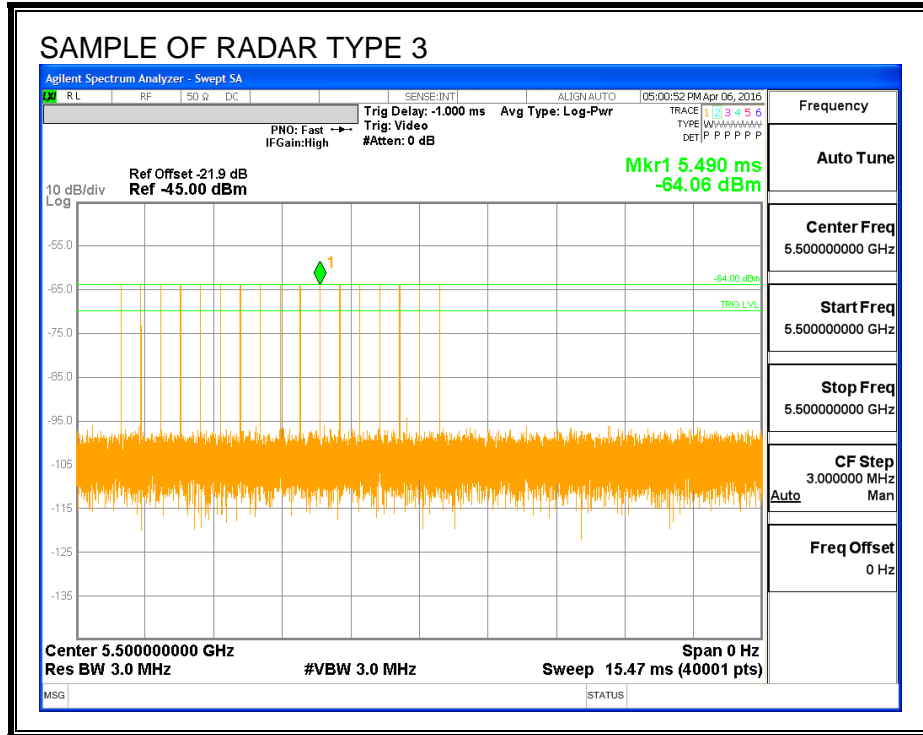

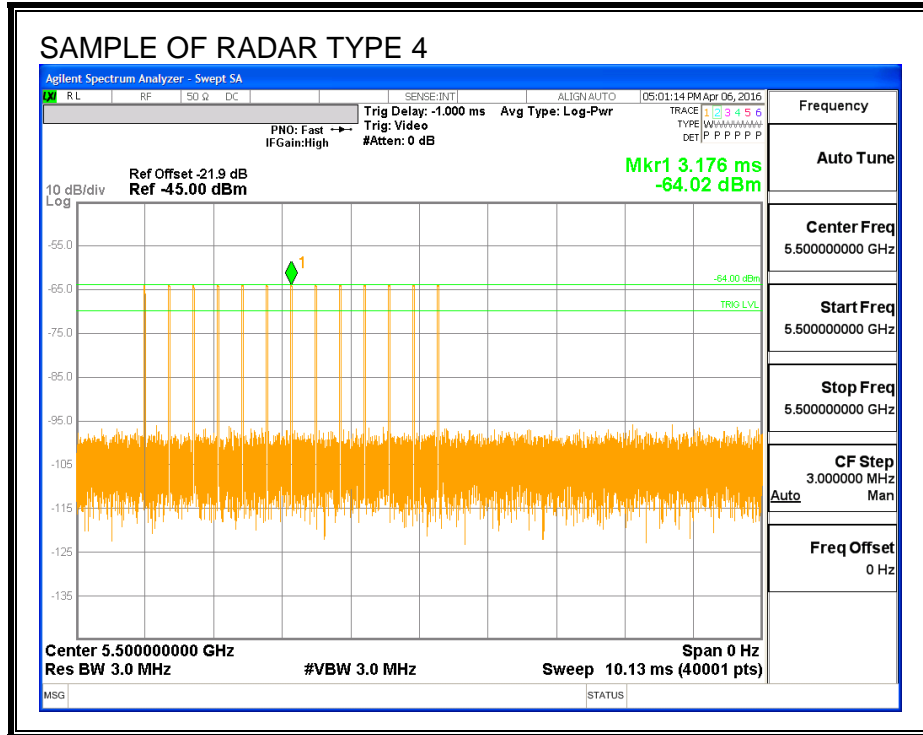

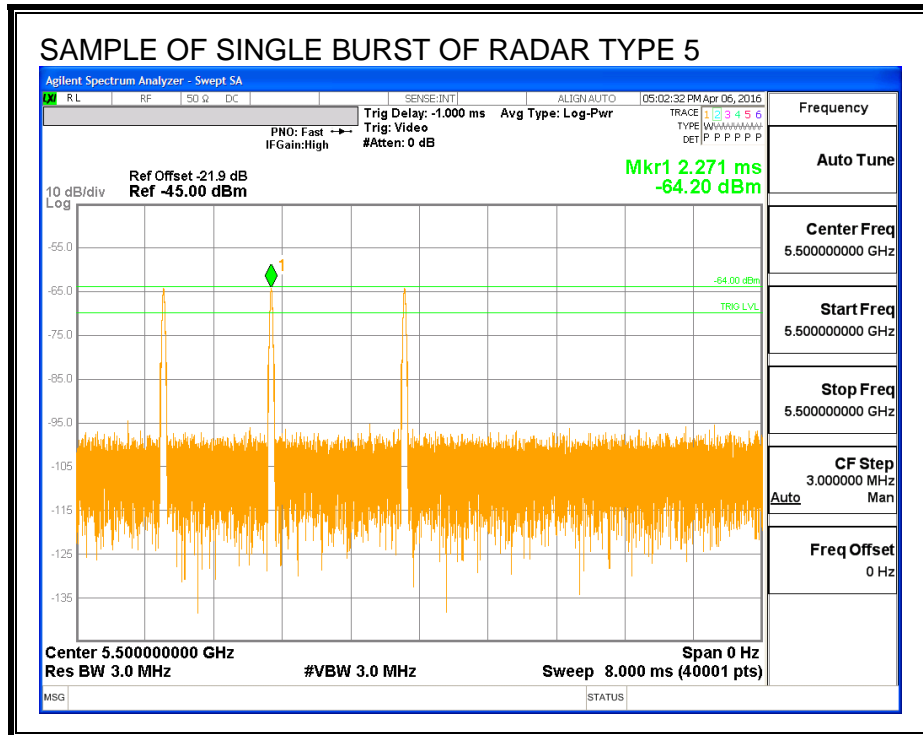

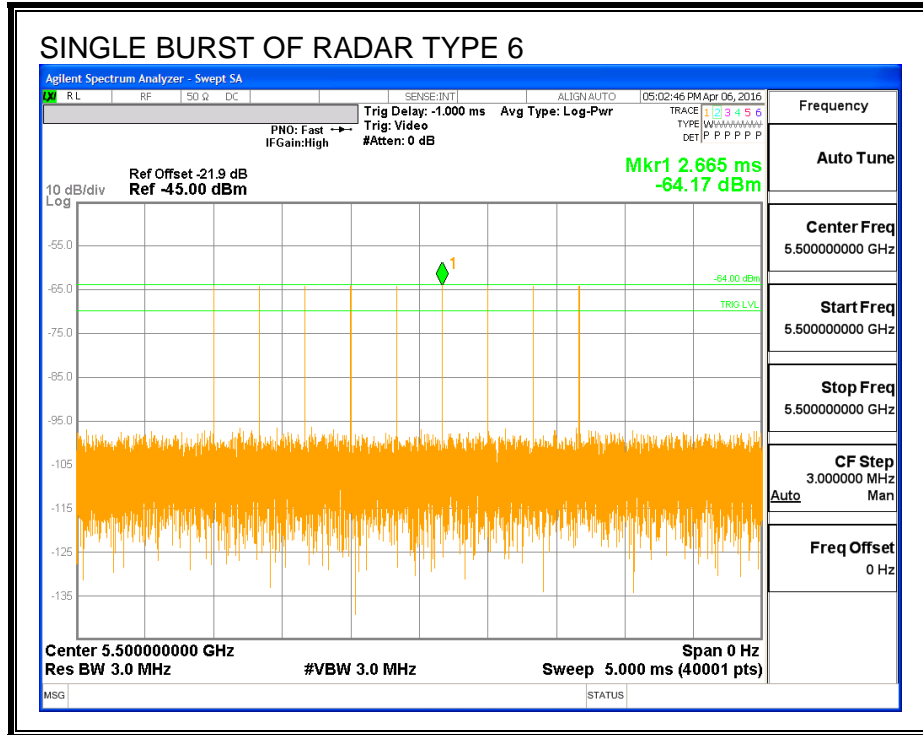

TRAFFIC

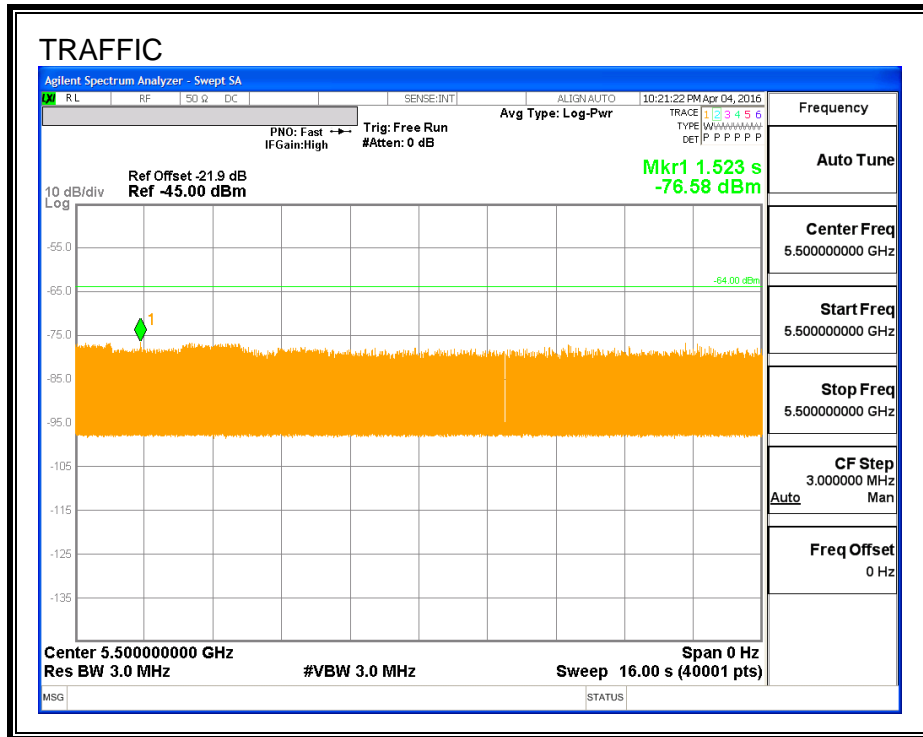

CHANNEL LOADING

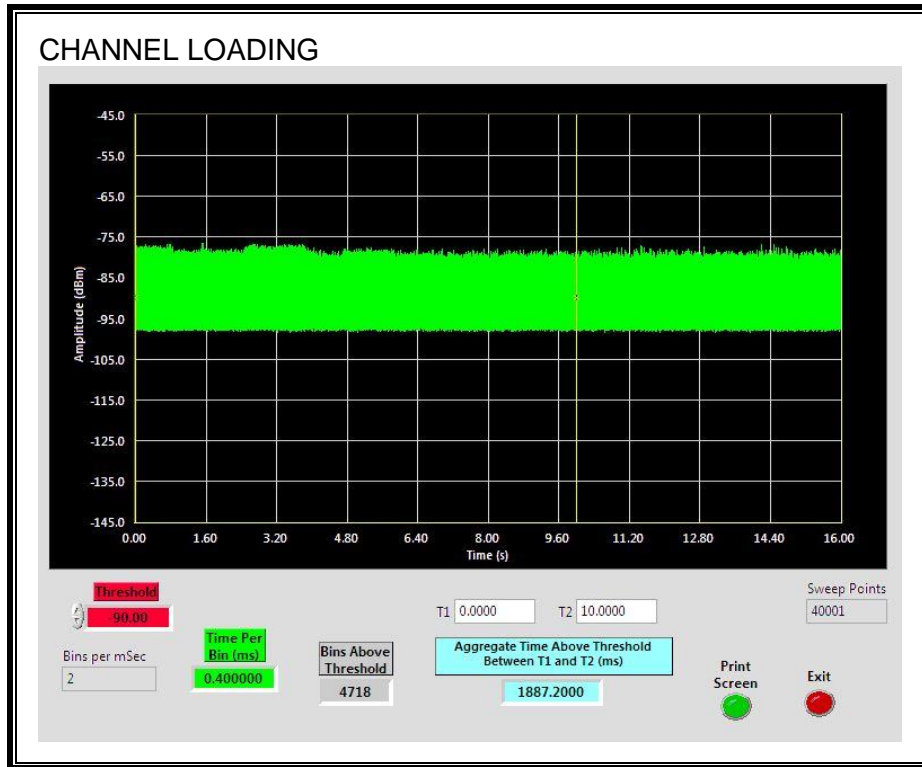

The level of traffic loading on the channel by the EUT is 18.872%

4.2.3. CHANNEL AVAILABILITY CHECK TIME

PROCEDURE TO DETERMINE INITIAL POWER-UP CYCLE TIME

A link was established on channel then the EUT was rebooted. The time from the cessation of traffic to the re-initialization of traffic was measured as the time required for the EUT to complete the total power-up cycle. The time to complete the initial power-up period is 60 seconds less than this total power-up time.

PROCEDURE FOR TIMING OF RADAR BURST

With a link established on channel, the EUT was rebooted. A radar signal was triggered within 0 to 6 seconds after the initial power-up period, and transmissions on the channel were monitored on the spectrum analyzer.

The Non-Occupancy list was cleared. With a link established on channel, the EUT was rebooted. A radar signal was triggered within 54 to 60 seconds after the initial power-up period, and transmissions on the channel were monitored on the spectrum analyzer.

QUANTITATIVE RESULTS

No Radar Triggered

Timing of Reboot (sec)	Timing of Start of Traffic (sec)	Total Power-up Cycle Time (sec)	Initial Power-up Cycle Time (sec)
30.23	142.2	112.0	52.0

Radar Near Beginning of CAC

Timing of Reboot (sec)	Timing of Radar Burst (sec)	Radar Relative to Reboot (sec)	Radar Relative to Start of CAC (sec)
30	83.2	53.2	1.2

Radar Near End of CAC

Timing of Reboot (sec)	Timing of Radar Burst (sec)	Radar Relative to Reboot (sec)	Radar Relative to Start of CAC (sec)
30.08	140.9	110.8	58.9

QUALITATIVE RESULTS

Timing of Radar Burst	Display on Control Computer	Spectrum Analyzer Display
No Radar Triggered	EUT marks Channel as active	Transmissions begin on channel after completion of the initial power-up cycle and the CAC
Within 0 to 6 second window	EUT indicates radar detected	No transmissions on channel
Within 54 to 60 second window	EUT indicates radar detected	No transmissions on channel

TIMING WITHOUT RADAR DURING CAC

AP is rebooted
 Traffic ceases
 Start of Initial Power-up cycle

End of Initial Power-up cycle
 Start of CAC

End of CAC
 Traffic is Initiated

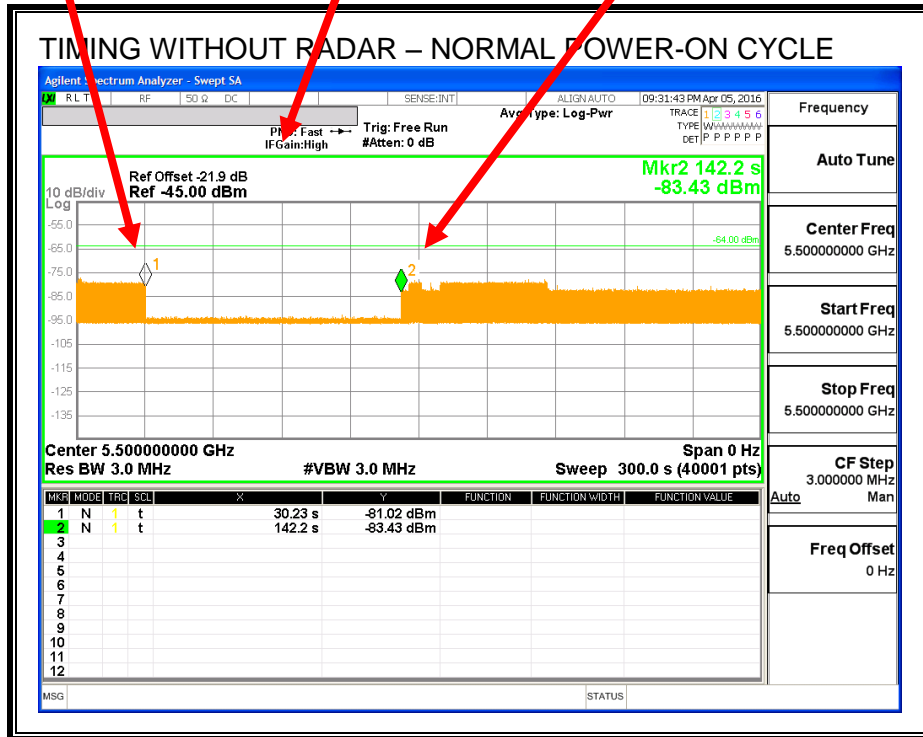

Transmissions begin on channel after completion of the initial power-up cycle and the CAC.

TIMING WITH RADAR NEAR BEGINNING OF CAC

AP is rebooted
 Traffic ceases
 Start of Initial Power-up cycle

End of Initial Power-up cycle
 Start of CAC

Radar Signal Applied

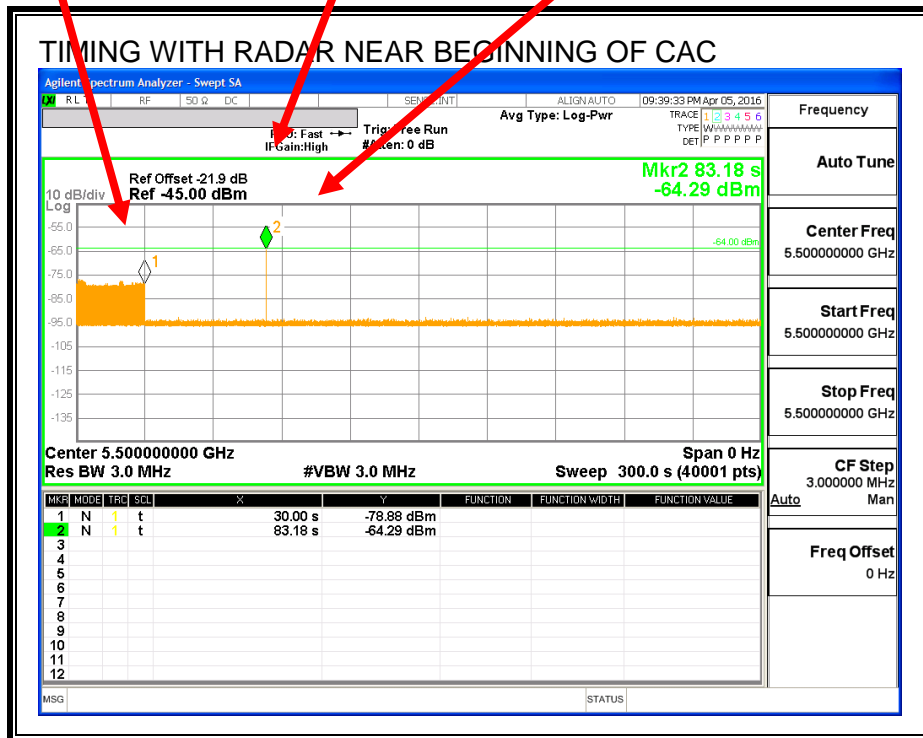

No EUT transmissions were observed after the radar signal.

TIMING WITH RADAR NEAR END OF CAC

AP is rebooted
 Traffic ceases
 Start of Initial Power-up cycle

End of Initial Power-up cycle
 Start of CAC

Radar Signal Applied

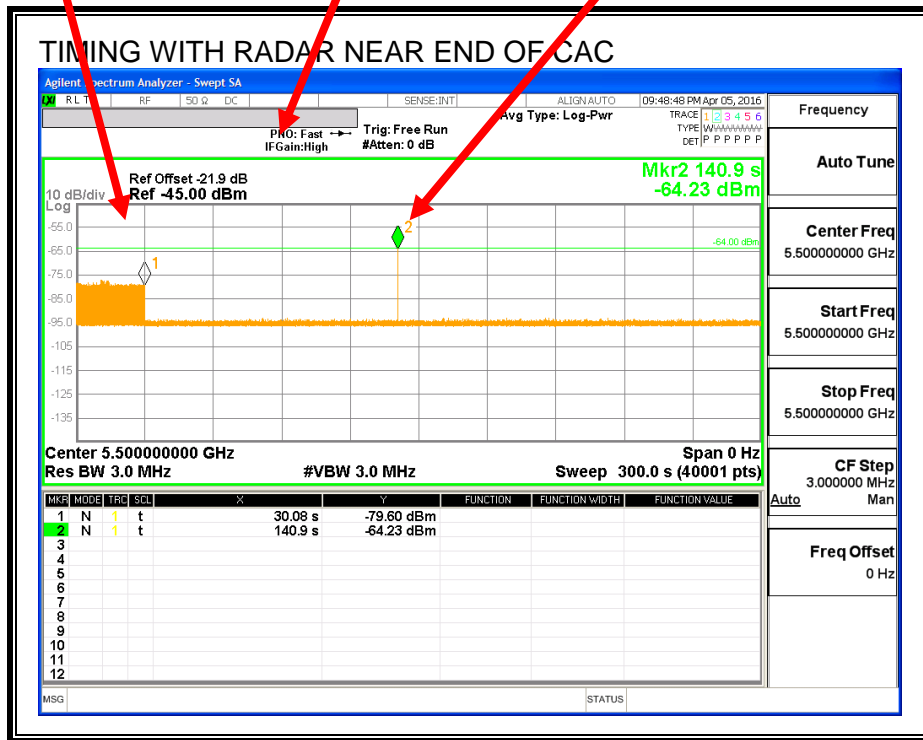

No EUT transmissions were observed after the radar signal.

4.2.4. OVERLAPPING CHANNEL TESTS

RESULTS

The channel spacing is not less than the channel bandwidth therefore the EUT does not have an overlapping channel plan.

These tests are not applicable.

4.2.5. MOVE AND CLOSING TIME

REPORTING NOTES

The reference marker is set at the end of last radar pulse.

The delta marker is set at the end of the last WLAN transmission following the radar pulse. This delta is the channel move time.

The aggregate channel closing transmission time is calculated as follows:

Aggregate Transmission Time =
(Number of analyzer bins showing transmission) * (dwell time per bin)

The observation period over which the aggregate time is calculated begins at (Reference Marker + 200 msec) and ends no earlier than (Reference Marker + 10 sec).

RESULTS

Channel Move Time (sec)	Limit (sec)
0.096	10

Aggregate Channel Closing Transmission Time (msec)	Limit (msec)
0.0	60

MOVE TIME

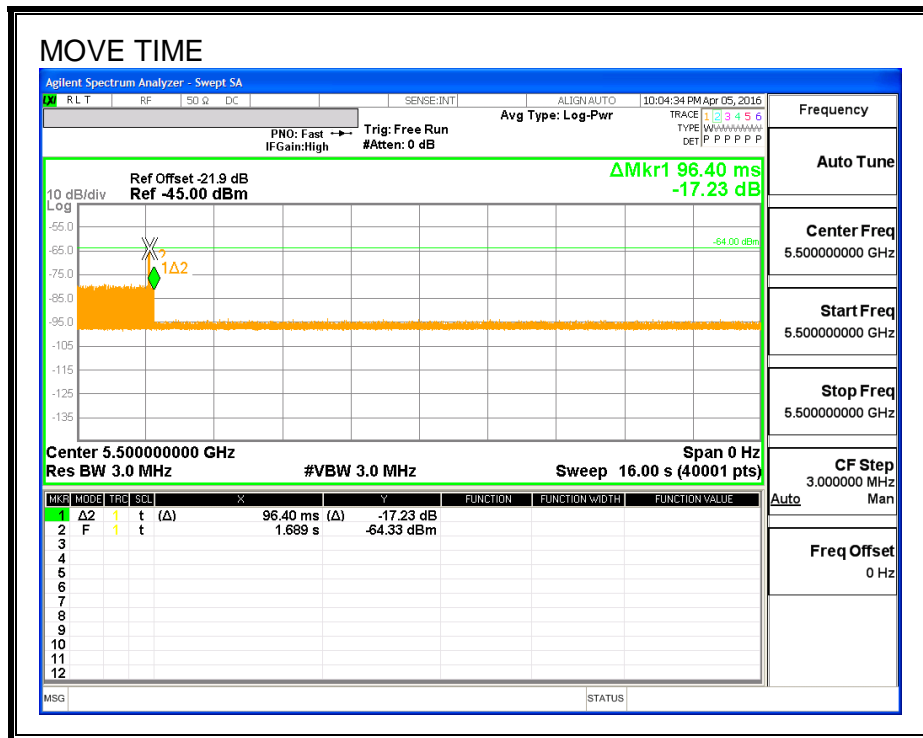

CHANNEL CLOSING TIME

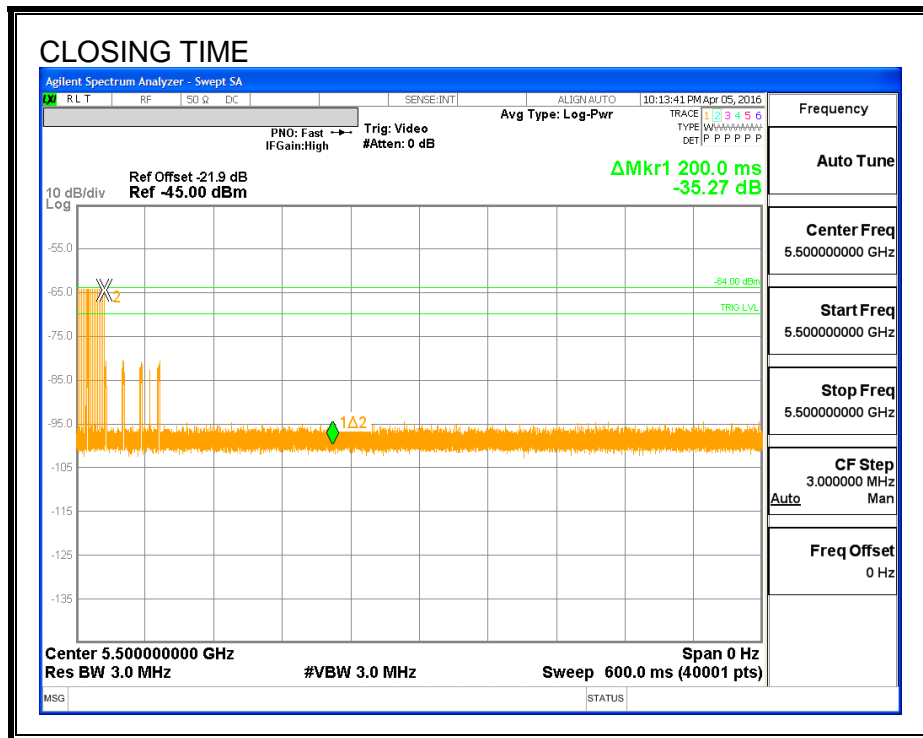

AGGREGATE CHANNEL CLOSING TRANSMISSION TIME

No transmissions are observed during the aggregate monitoring period.

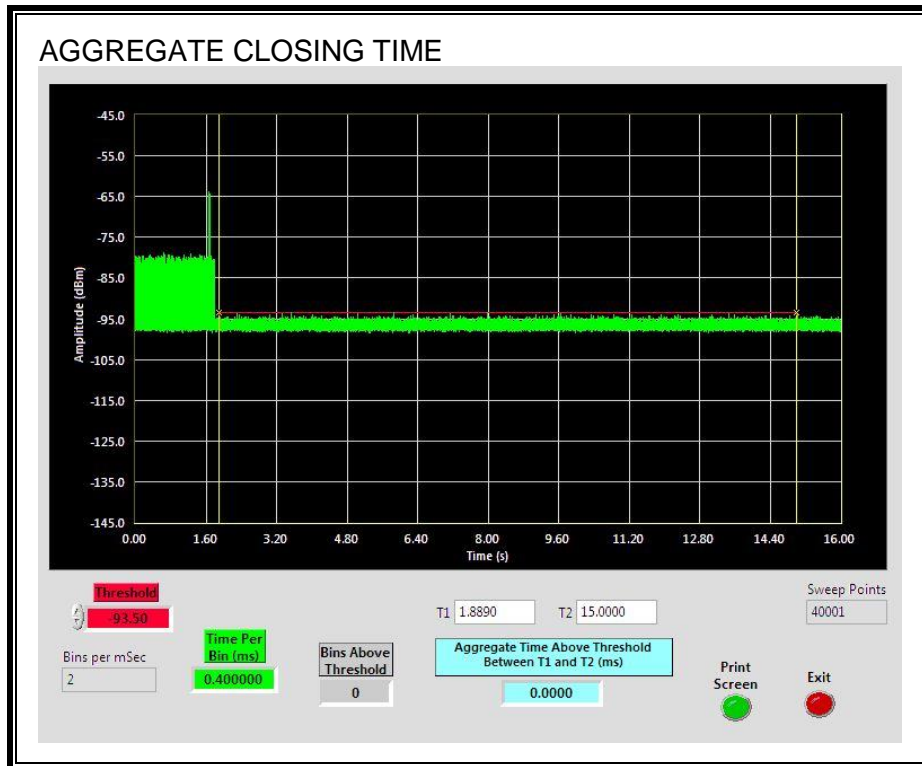

LONG PULSE CHANNEL MOVE TIME

The traffic ceases prior to 10 seconds after the end of the radar waveform.

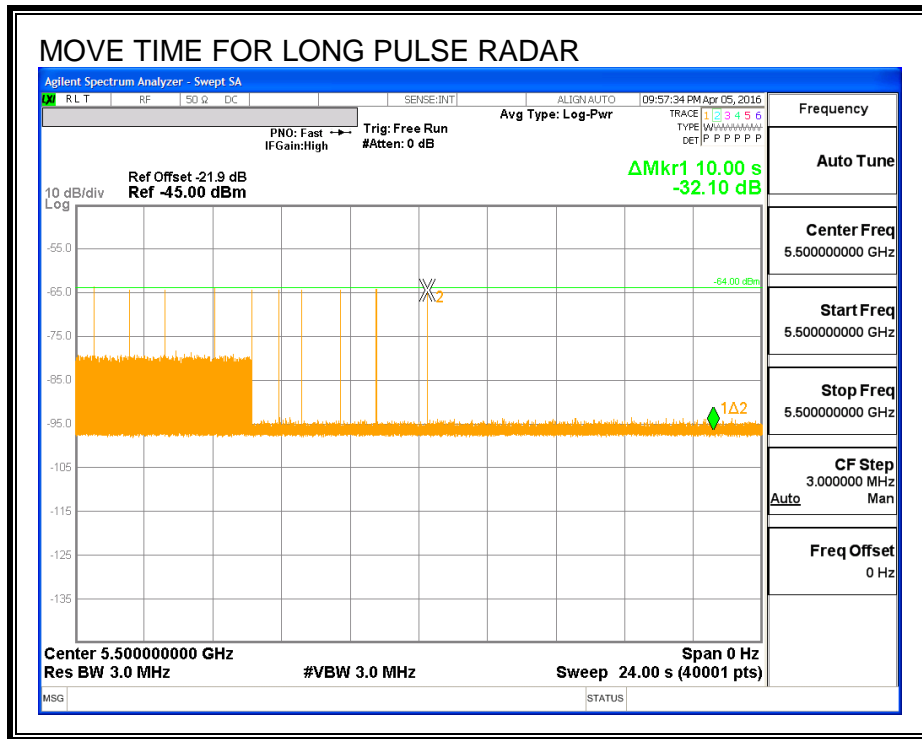

4.2.6. DETECTION BANDWIDTH

REFERENCE PLOT OF 99% POWER BANDWIDTH

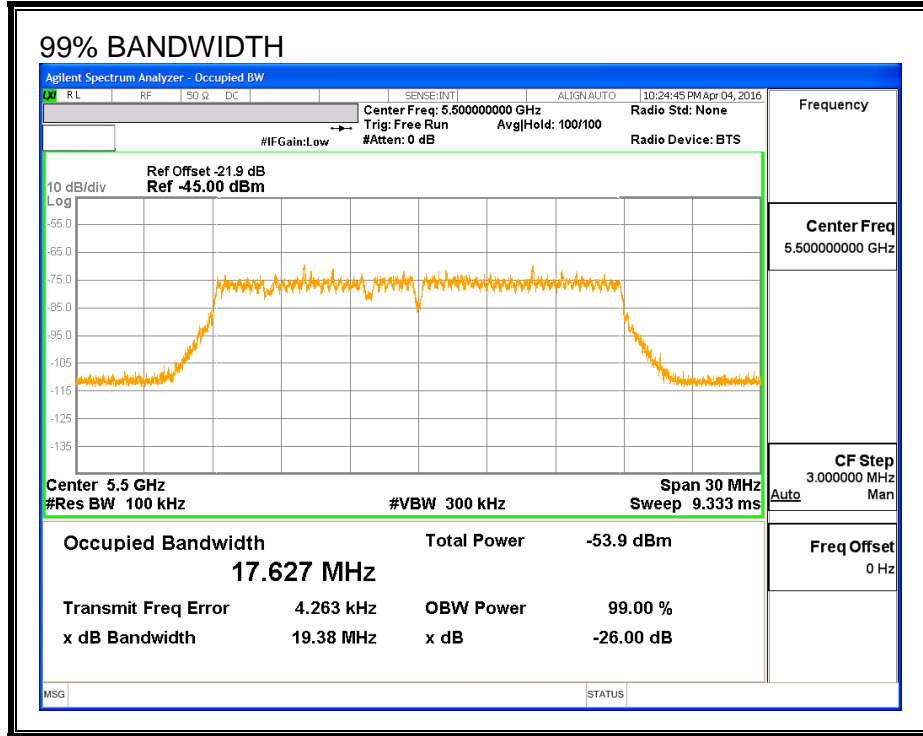

RESULTS

FL	FH	Detection Bandwidth	99% Power Bandwidth	Ratio of Detection BW to 99% Power BW	Minimum Limit
(MHz)	(MHz)	(MHz)	(MHz)	(%)	(%)
5491	5509	18	17.627	102.1	100

DETECTION BANDWIDTH PROBABILITY

DETECTION BANDWIDTH PROBABILITY RESULTS				
Detection Bandwidth Test Results				
FCC Type 0 Waveform: 1 us Pulse Width, 1428 us PRI, 18 Pulses per Burst				
Frequency (MHz)	Number of Trials	Number Detected	Detection (%)	Mark
5490	10	0	0	
5491	10	9	90	FL
5492	10	10	100	
5493	10	10	100	
5494	10	10	100	
5495	10	10	100	
5500	10	10	100	
5505	10	10	100	
5506	10	10	100	
5507	10	10	100	
5508	10	10	100	
5509	10	10	100	FH
5510	10	0	0	

4.2.7. IN-SERVICE MONITORING

RESULTS

FCC Radar Test Summary								
Signal Type	Number of Trials	Detection (%)	Limit (%)	Pass/Fail	Detection Bandwidth		80% of Det BW	
					FL	FH	FL5	FH5
FCC Short Pulse Type 1	30	100.00	60	Pass	5491	5509		
FCC Short Pulse Type 2	30	100.00	60	Pass	5491	5509		
FCC Short Pulse Type 3	30	100.00	60	Pass	5491	5509		
FCC Short Pulse Type 4	30	93.33	60	Pass	5491	5509		
Aggregate		98.33	80	Pass				
FCC Long Pulse Type 5	30	96.67	80	Pass	5491	5509	5493	5507
FCC Hopping Type 6	38	100.00	70	Pass	5491	5509		

TYPE 1 DETECTION PROBABILITY

Data Sheet for FCC Short Pulse Radar Type 1						
Waveform	Pulse Width (us)	PRI (us)	Pulses Per Burst	Test (A/B)	Frequency (MHz)	Successful Detection (Yes/No)
1001	1	3066	18	A	5500	Yes
1002	1	698	76	A	5500	Yes
1003	1	578	92	A	5500	Yes
1004	1	858	62	A	5500	Yes
1005	1	558	95	A	5500	Yes
1006	1	638	83	A	5500	Yes
1007	1	798	67	A	5500	Yes
1008	1	918	58	A	5500	Yes
1009	1	898	59	A	5500	Yes
1010	1	598	89	A	5500	Yes
1011	1	538	99	A	5500	Yes
1012	1	778	68	A	5500	Yes
1013	1	818	65	A	5500	Yes
1014	1	618	86	A	5500	Yes
1015	1	718	74	A	5500	Yes
1016	1	2395	23	B	5500	Yes
1017	1	1480	36	B	5500	Yes
1018	1	2242	24	B	5500	Yes
1019	1	1456	37	B	5500	Yes
1020	1	1153	46	B	5500	Yes
1021	1	1850	29	B	5500	Yes
1022	1	2871	19	B	5500	Yes
1023	1	2504	22	B	5500	Yes
1024	1	1583	34	B	5500	Yes
1025	1	2539	21	B	5500	Yes
1026	1	1429	37	B	5500	Yes
1027	1	1321	40	B	5500	Yes
1028	1	2889	19	B	5500	Yes
1029	1	2909	19	B	5500	Yes
1030	1	865	62	B	5500	Yes

TYPE 2 DETECTION PROBABILITY

Data Sheet for FCC Short Pulse Radar Type 2					
Waveform	Pulse Width (us)	PRI (us)	Pulses Per Burst	Frequency (MHz)	Successful Detection (Yes/No)
2001	4.6	169	26	5500	Yes
2002	2.8	212	28	5500	Yes
2003	3.7	206	27	5500	Yes
2004	2.1	215	26	5500	Yes
2005	1.2	213	29	5500	Yes
2006	2	226	28	5500	Yes
2007	3.3	190	28	5500	Yes
2008	2.4	208	24	5500	Yes
2009	1.9	219	29	5500	Yes
2010	3.1	159	25	5500	Yes
2011	1	174	29	5500	Yes
2012	4.6	162	23	5500	Yes
2013	2.6	181	25	5500	Yes
2014	2.3	173	29	5500	Yes
2015	4.7	158	27	5500	Yes
2016	2.7	154	25	5500	Yes
2017	3.3	225	24	5500	Yes
2018	1.5	187	26	5500	Yes
2019	2.4	224	29	5500	Yes
2020	4.9	190	24	5500	Yes
2021	4	230	27	5500	Yes
2022	4.8	201	26	5500	Yes
2023	4.2	165	23	5500	Yes
2024	1.1	182	29	5500	Yes
2025	4.7	193	26	5500	Yes
2026	4	214	23	5500	Yes
2027	3.8	230	24	5500	Yes
2028	3.3	217	28	5500	Yes
2029	1.3	156	29	5500	Yes
2030	1	228	27	5500	Yes

TYPE 3 DETECTION PROBABILITY

Data Sheet for FCC Short Pulse Radar Type 3					
Waveform	Pulse Width (us)	PRI (us)	Pulses Per Burst	Frequency (MHz)	Successful Detection (Yes/No)
3001	5.6	449	17	5500	Yes
3002	5.5	436	16	5500	Yes
3003	6.3	404	18	5500	Yes
3004	9.1	286	17	5500	Yes
3005	5.1	400	17	5500	Yes
3006	5.8	294	18	5500	Yes
3007	7.2	421	16	5500	Yes
3008	8.1	329	16	5500	Yes
3009	7.3	468	18	5500	Yes
3010	8.6	404	17	5500	Yes
3011	8	305	16	5500	Yes
3012	7.1	371	18	5500	Yes
3013	6.9	419	18	5500	Yes
3014	6.2	380	17	5500	Yes
3015	8.9	440	17	5500	Yes
3016	8.5	414	16	5500	Yes
3017	9.1	369	16	5500	Yes
3018	9	490	16	5500	Yes
3019	9.8	458	17	5500	Yes
3020	7.5	457	17	5500	Yes
3021	8.6	320	16	5500	Yes
3022	9.3	466	17	5500	Yes
3023	5.6	342	16	5500	Yes
3024	6.5	500	18	5500	Yes
3025	5.7	271	17	5500	Yes
3026	7	324	16	5500	Yes
3027	6.4	477	18	5500	Yes
3028	5.5	425	17	5500	Yes
3029	5.2	339	17	5500	Yes
3030	9.7	301	16	5500	Yes

TYPE 4 DETECTION PROBABILITY

Data Sheet for FCC Short Pulse Radar Type 4					
Waveform	Pulse Width (us)	PRI (us)	Pulses Per Burst	Frequency (MHz)	Successful Detection (Yes/No)
4001	14.6	361	13	5500	Yes
4002	19.2	468	16	5500	Yes
4003	15	290	15	5500	Yes
4004	20	410	16	5500	Yes
4005	16.3	378	15	5500	Yes
4006	11.8	260	12	5500	Yes
4007	14	492	16	5500	Yes
4008	15.4	387	15	5500	Yes
4009	18.1	262	15	5500	No
4010	20	303	14	5500	Yes
4011	18.4	442	12	5500	Yes
4012	10.7	496	12	5500	Yes
4013	19.8	397	12	5500	No
4014	18	346	12	5500	Yes
4015	17.4	260	13	5500	Yes
4016	16.2	472	16	5500	Yes
4017	11.4	415	12	5500	Yes
4018	16	389	12	5500	Yes
4019	11.8	462	14	5500	Yes
4020	16.9	331	15	5500	Yes
4021	13.1	299	14	5500	Yes
4022	18.7	432	15	5500	Yes
4023	16.2	412	15	5500	Yes
4024	12.2	307	14	5500	Yes
4025	14.9	434	13	5500	Yes
4026	16.8	475	13	5500	Yes
4027	15.2	363	15	5500	Yes
4028	17.6	417	15	5500	Yes
4029	16.6	318	16	5500	Yes
4030	14.8	267	15	5500	Yes

TYPE 5 DETECTION PROBABILITY

Data Sheet for FCC Long Pulse Radar Type 5		
Trial	Frequency (MHz)	Successful Detection (Yes/No)
1	5506	Yes
2	5495	Yes
3	5499	Yes
4	5498	Yes
5	5505	Yes
6	5502	Yes
7	5503	Yes
8	5503	Yes
9	5503	Yes
10	5496	Yes
11	5496	Yes
12	5496	Yes
13	5495	Yes
14	5494	No
15	5495	Yes
16	5502	Yes
17	5496	Yes
18	5494	Yes
19	5499	Yes
20	5496	Yes
21	5507	Yes
22	5506	Yes
23	5502	Yes
24	5507	Yes
25	5505	Yes
26	5505	Yes
27	5500	Yes
28	5502	Yes
29	5499	Yes
30	5502	Yes

Note: The Type 5 randomized parameters tested are shown in a separate document.

TYPE 6 DETECTION PROBABILITY

Data Sheet for FCC Hopping Radar Type 6				
1 us Pulse Width, 333 us PRI, 9 Pulses per Burst, 1 Burst per Hop				
NTIA August 2005 Hopping Sequence				
Trial	Starting Index Within Sequence	Signal Generator Frequency (MHz)	Hops within Detection BW	Successful Detection (Yes/No)
1	26	5491	5	Yes
2	501	5492	4	Yes
3	976	5493	4	Yes
4	1451	5494	5	Yes
5	1926	5495	7	Yes
6	2401	5496	5	Yes
7	2876	5497	4	Yes
8	3351	5498	4	Yes
9	3826	5499	5	Yes
10	4301	5500	4	Yes
11	4776	5501	6	Yes
12	5251	5502	3	Yes
13	5726	5503	3	Yes
14	6201	5504	4	Yes
15	6676	5505	3	Yes
16	7151	5506	5	Yes
17	7626	5507	6	Yes
18	8101	5508	1	Yes
19	8576	5509	3	Yes
20	9051	5491	3	Yes
21	9526	5492	4	Yes
22	10001	5493	3	Yes
23	10476	5494	2	Yes
24	10951	5495	7	Yes
25	11426	5496	3	Yes
26	11901	5497	5	Yes
27	12376	5498	4	Yes
28	12851	5499	4	Yes
29	13326	5500	4	Yes
30	13801	5501	4	Yes
31	14751	5502	4	Yes
32	15226	5503	5	Yes
33	15701	5504	5	Yes
34	16176	5505	3	Yes
35	16651	5506	2	Yes
36	17126	5507	5	Yes
37	17601	5508	6	Yes
38	18076	5509	5	Yes

4.3. RESULTS FOR 40 MHz BANDWIDTH

4.3.1. TEST CHANNEL

All tests were performed at a channel center frequency of 5510 MHz.

4.3.2. RADAR WAVEFORMS AND TRAFFIC

RADAR WAVEFORMS

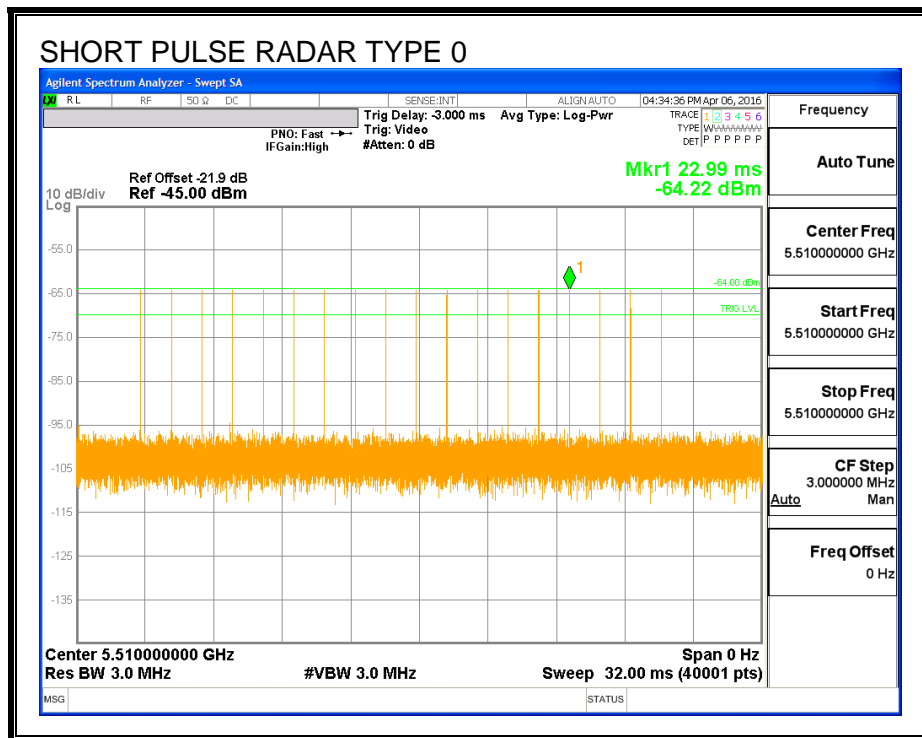

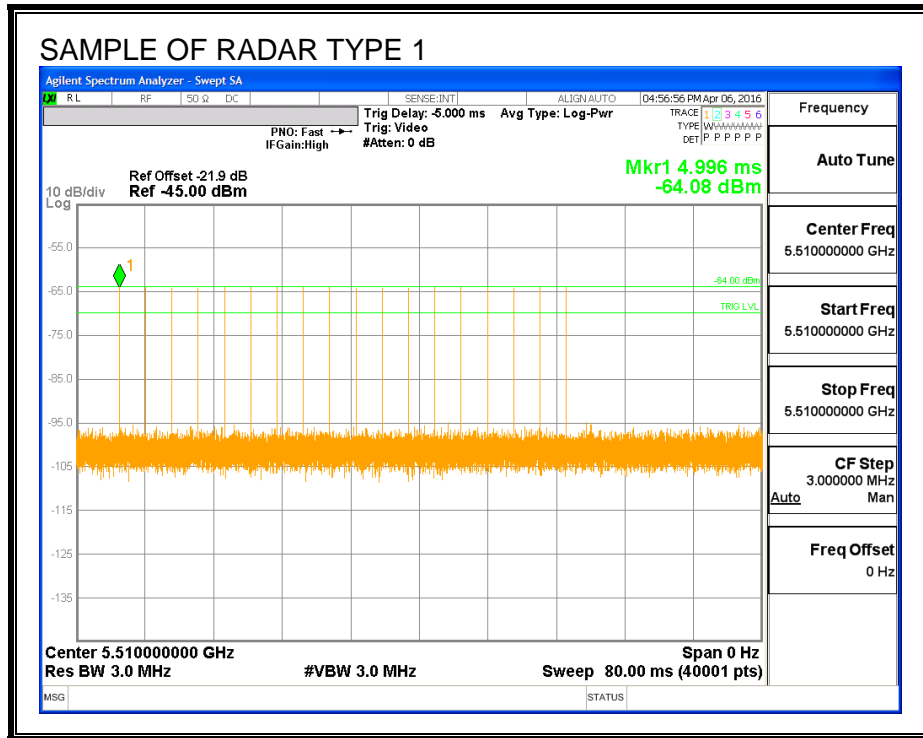

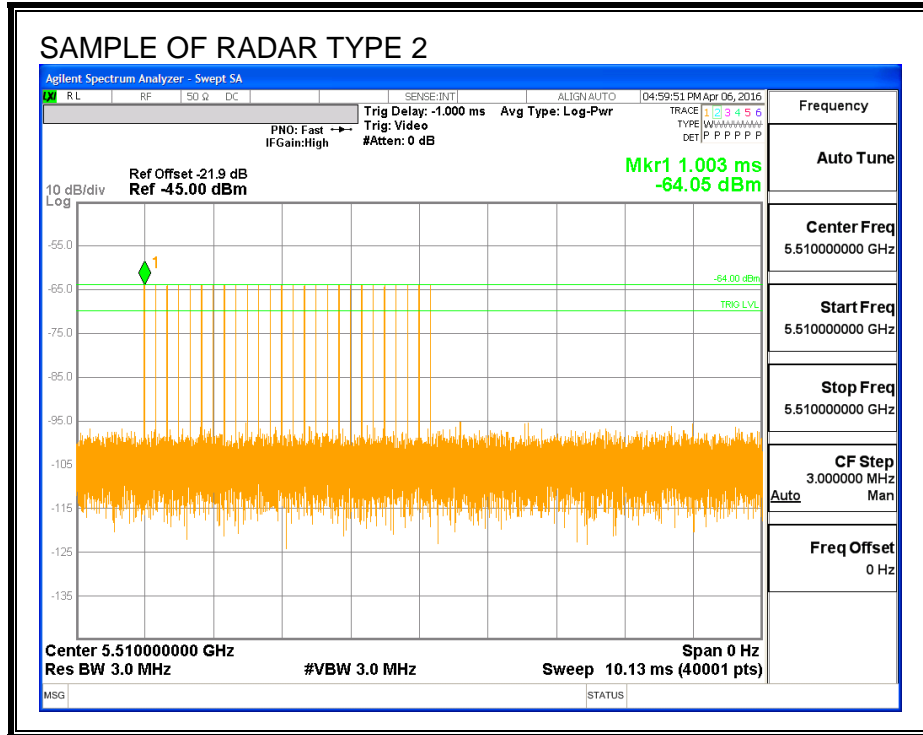

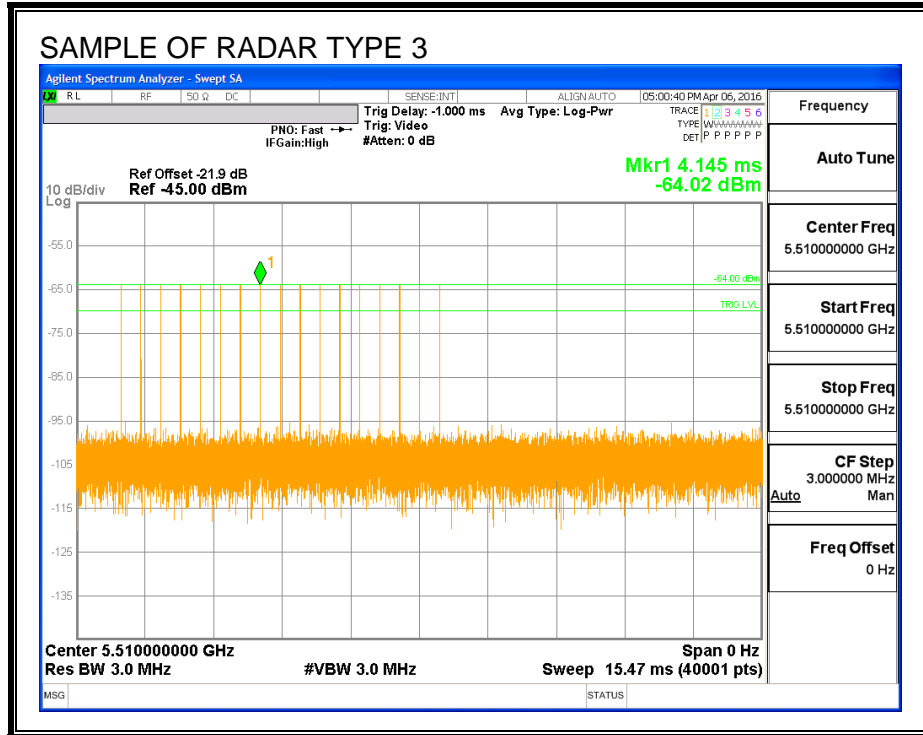

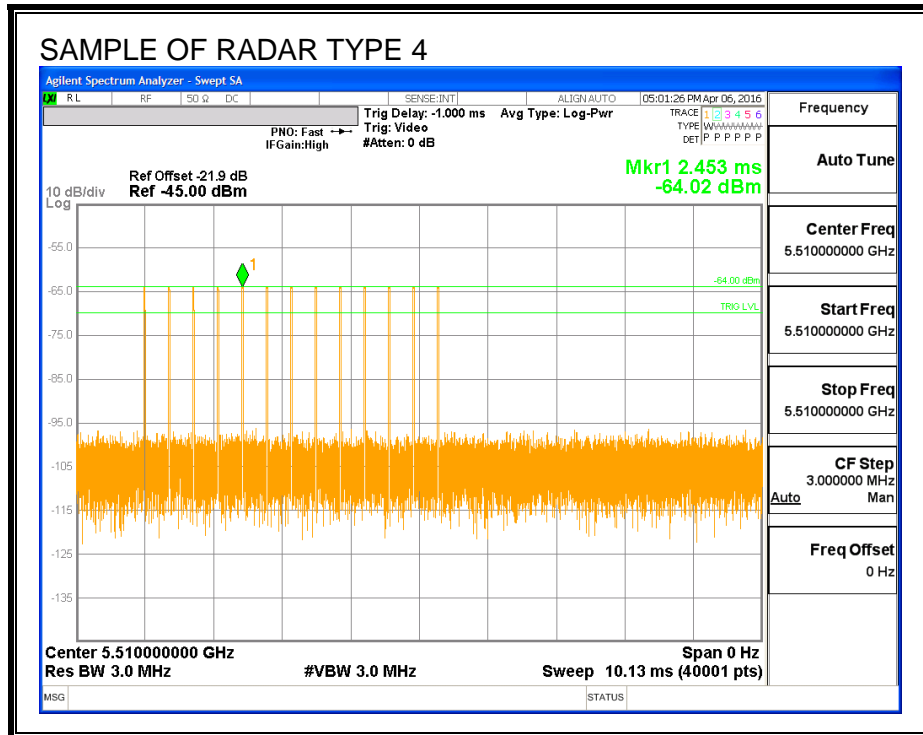

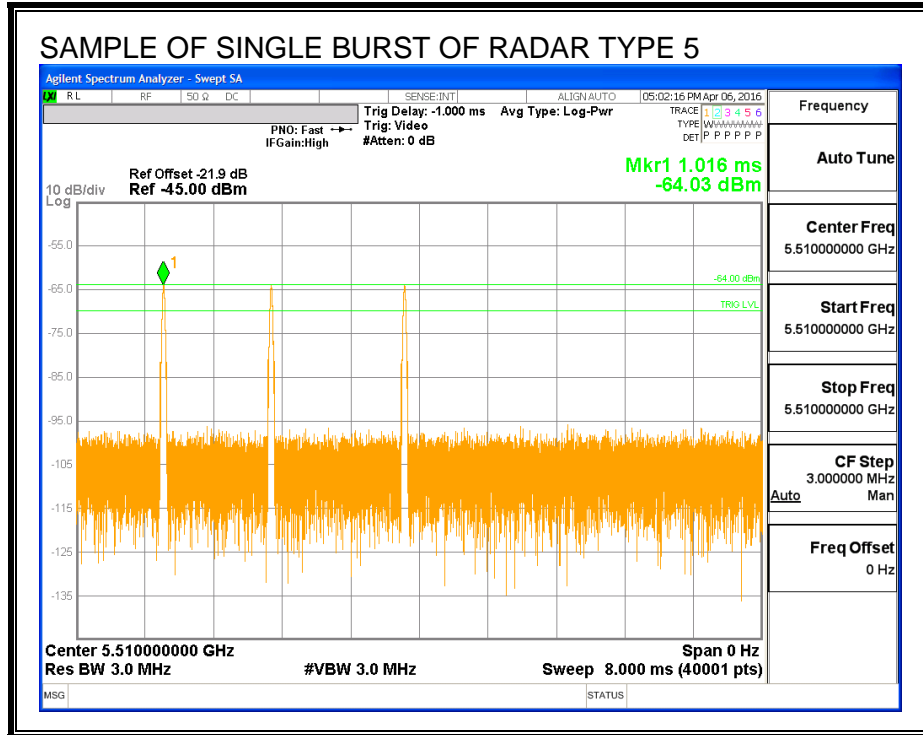

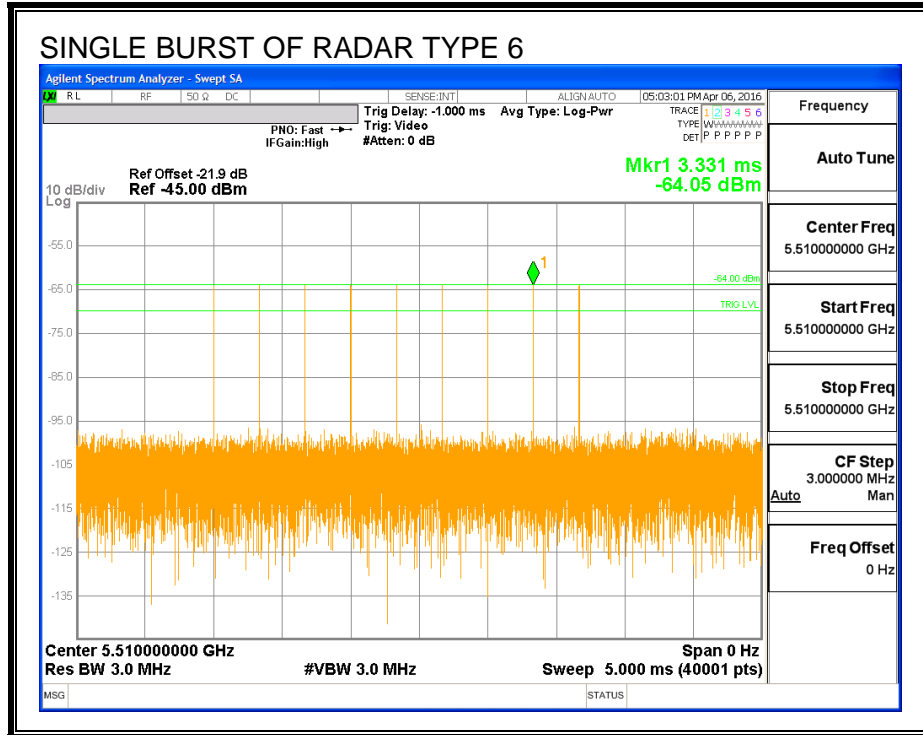

TRAFFIC

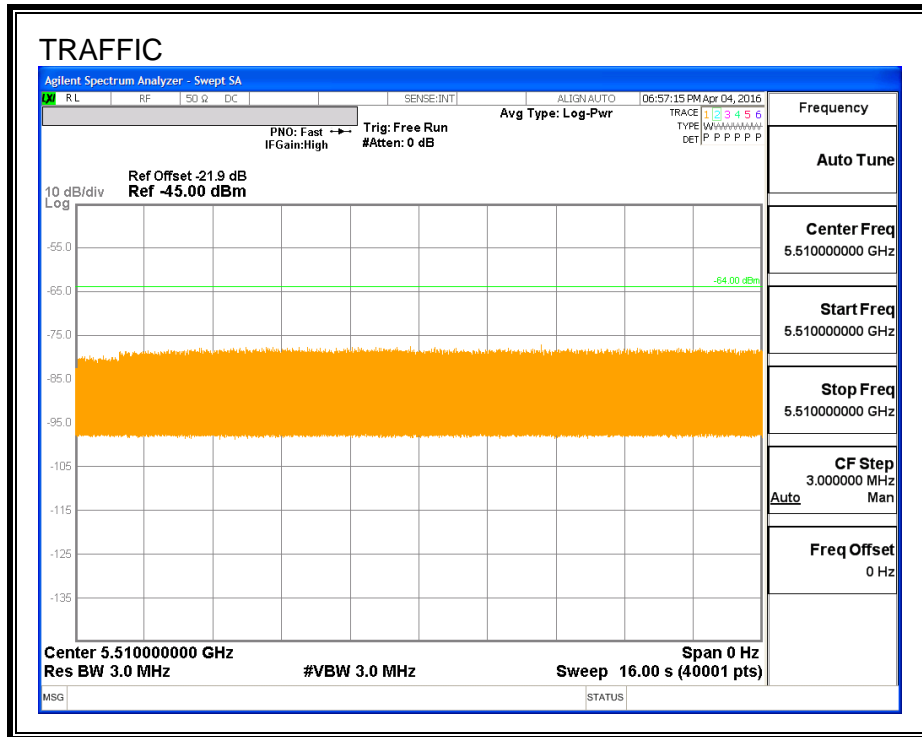

CHANNEL LOADING

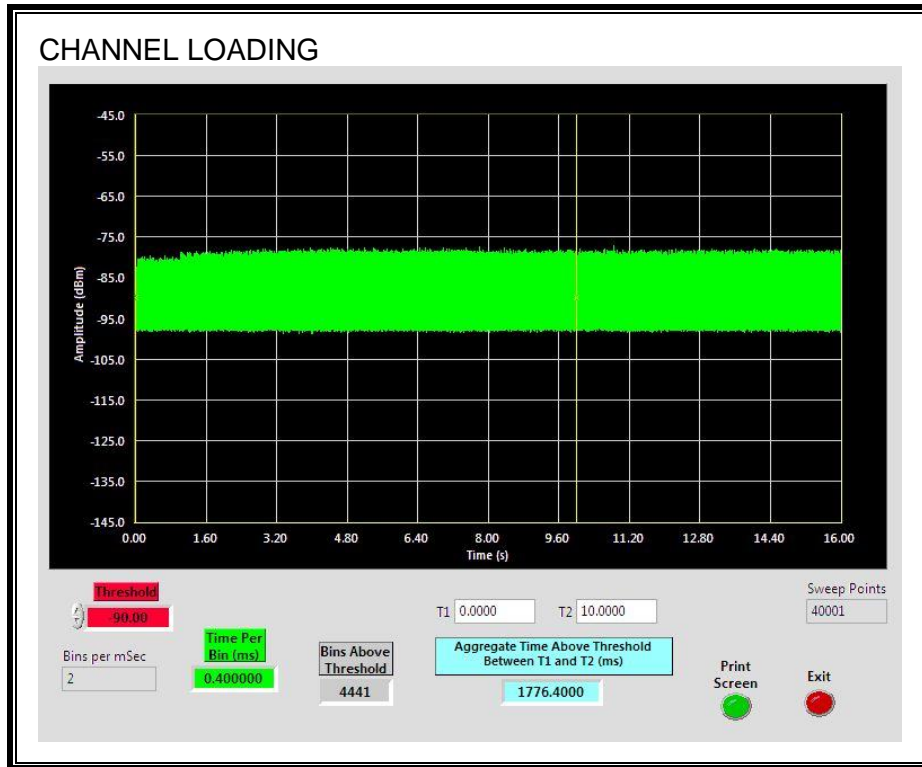

The level of traffic loading on the channel by the EUT is 17.764%

4.3.3. CHANNEL AVAILABILITY CHECK TIME

PROCEDURE TO DETERMINE INITIAL POWER-UP CYCLE TIME

A link was established on channel then the EUT was rebooted. The time from the cessation of traffic to the re-initialization of traffic was measured as the time required for the EUT to complete the total power-up cycle. The time to complete the initial power-up period is 60 seconds less than this total power-up time.

PROCEDURE FOR TIMING OF RADAR BURST

With a link established on channel, the EUT was rebooted. A radar signal was triggered within 0 to 6 seconds after the initial power-up period, and transmissions on the channel were monitored on the spectrum analyzer.

The Non-Occupancy list was cleared. With a link established on channel, the EUT was rebooted. A radar signal was triggered within 54 to 60 seconds after the initial power-up period, and transmissions on the channel were monitored on the spectrum analyzer.

QUANTITATIVE RESULTS

No Radar Triggered

Timing of Reboot (sec)	Timing of Start of Traffic (sec)	Total Power-up Cycle Time (sec)	Initial Power-up Cycle Time (sec)
29.89	141.5	111.6	51.6

Radar Near Beginning of CAC

Timing of Reboot (sec)	Timing of Radar Burst (sec)	Radar Relative to Reboot (sec)	Radar Relative to Start of CAC (sec)
29.96	82.4	52.5	0.9

Radar Near End of CAC

Timing of Reboot (sec)	Timing of Radar Burst (sec)	Radar Relative to Reboot (sec)	Radar Relative to Start of CAC (sec)
30.2	140.5	110.3	58.7

QUALITATIVE RESULTS

Timing of Radar Burst	Display on Control Computer	Spectrum Analyzer Display
No Radar Triggered	EUT marks Channel as active	Transmissions begin on channel after completion of the initial power-up cycle and the CAC
Within 0 to 6 second window	EUT indicates radar detected	No transmissions on channel
Within 54 to 60 second window	EUT indicates radar detected	No transmissions on channel

TIMING WITHOUT RADAR DURING CAC

AP is rebooted
 Traffic ceases
 Start of Initial Power-up cycle

End of Initial Power-up cycle
 Start of CAC

End of CAC
 Traffic is Initiated

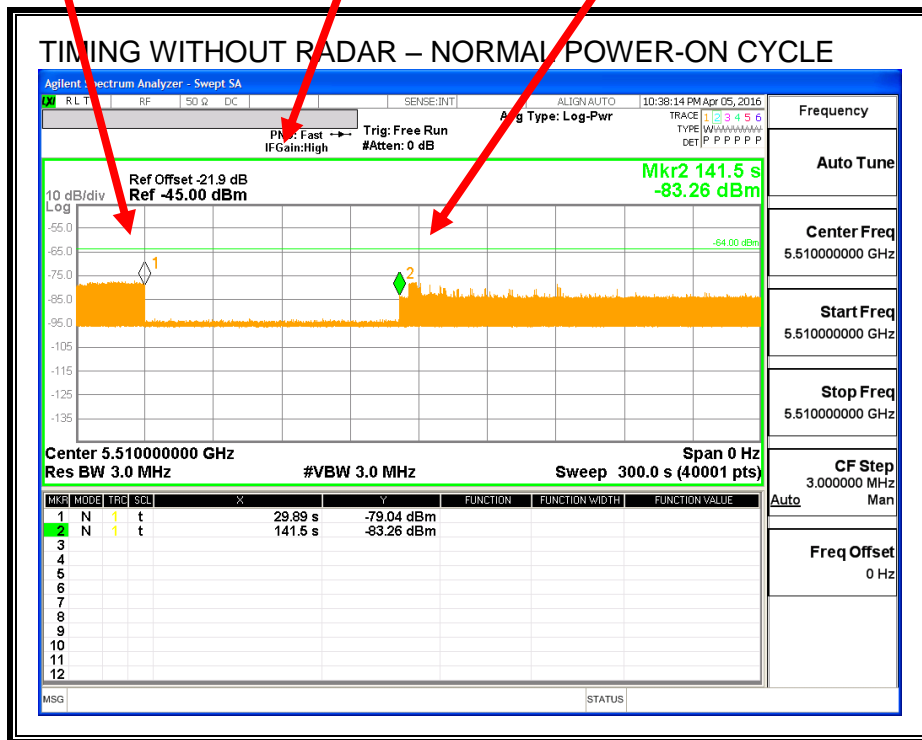

Transmissions begin on channel after completion of the initial power-up cycle and the CAC.

TIMING WITH RADAR NEAR BEGINNING OF CAC

AP is rebooted
 Traffic ceases
 Start of Initial Power-up cycle

End of Initial Power-up cycle
 Start of CAC

Radar Signal Applied

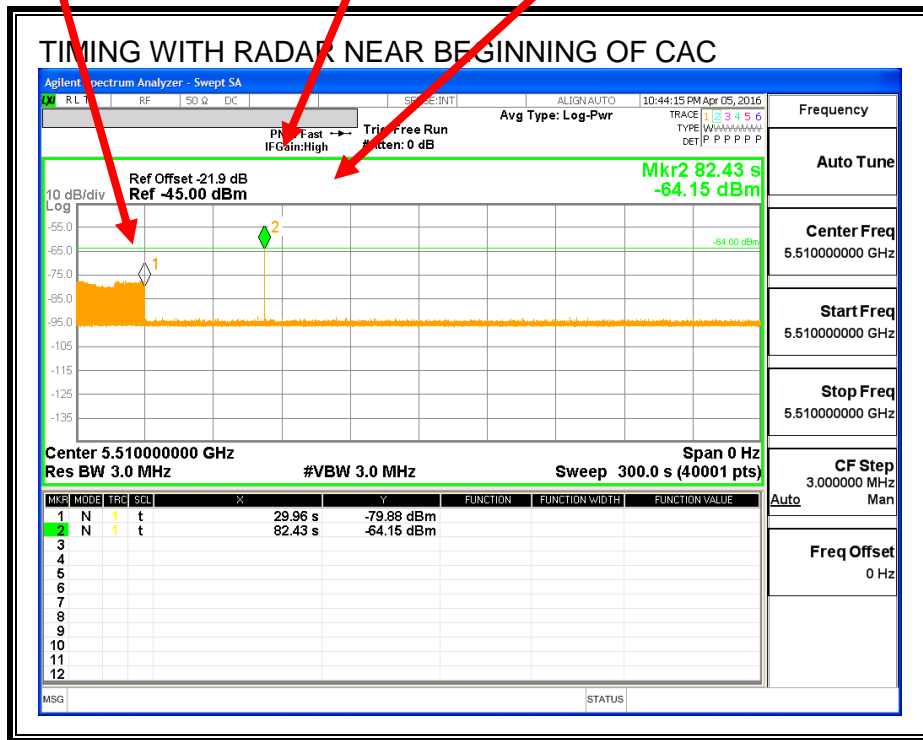

No EUT transmissions were observed after the radar signal.

TIMING WITH RADAR NEAR END OF CAC

AP is rebooted
 Traffic ceases
 Start of Initial Power-up cycle

End of Initial Power-up cycle
 Start of CAC

Radar Signal Applied

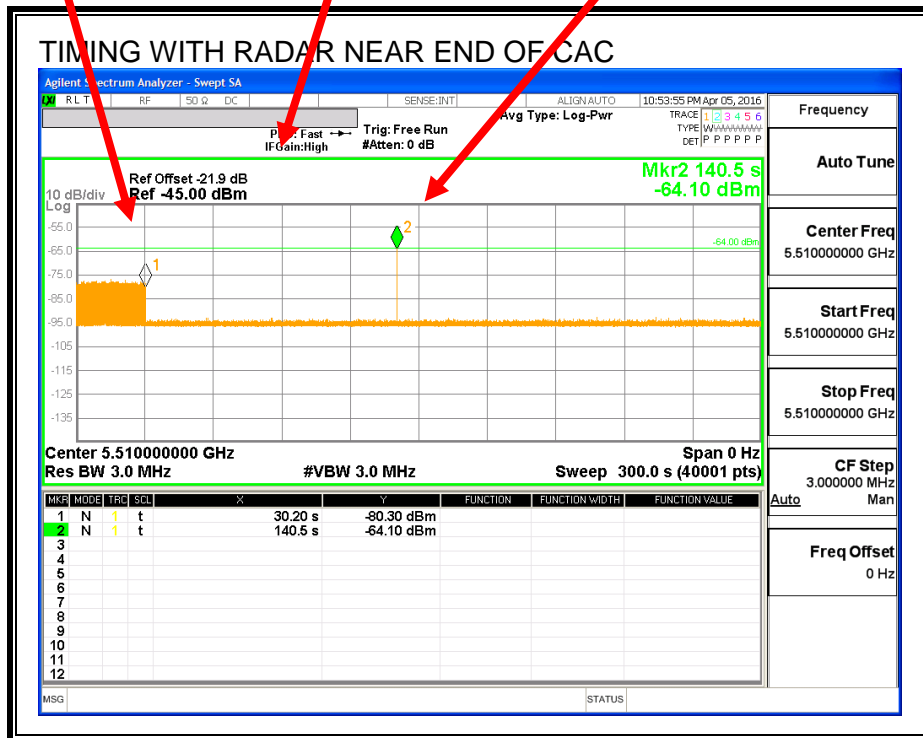

No EUT transmissions were observed after the radar signal.

4.3.1. OVERLAPPING CHANNEL TESTS

RESULTS

The channel spacing is not less than the channel bandwidth therefore the EUT does not have an overlapping channel plan.

These tests are not applicable.

4.3.2. MOVE AND CLOSING TIME

REPORTING NOTES

The reference marker is set at the end of last radar pulse.

The delta marker is set at the end of the last WLAN transmission following the radar pulse. This delta is the channel move time.

The aggregate channel closing transmission time is calculated as follows:

Aggregate Transmission Time =
(Number of analyzer bins showing transmission) * (dwell time per bin)

The observation period over which the aggregate time is calculated begins at (Reference Marker + 200 msec) and ends no earlier than (Reference Marker + 10 sec).

RESULTS

Channel Move Time (sec)	Limit (sec)
0.088	10

Aggregate Channel Closing Transmission Time (msec)	Limit (msec)
0.0	60

MOVE TIME

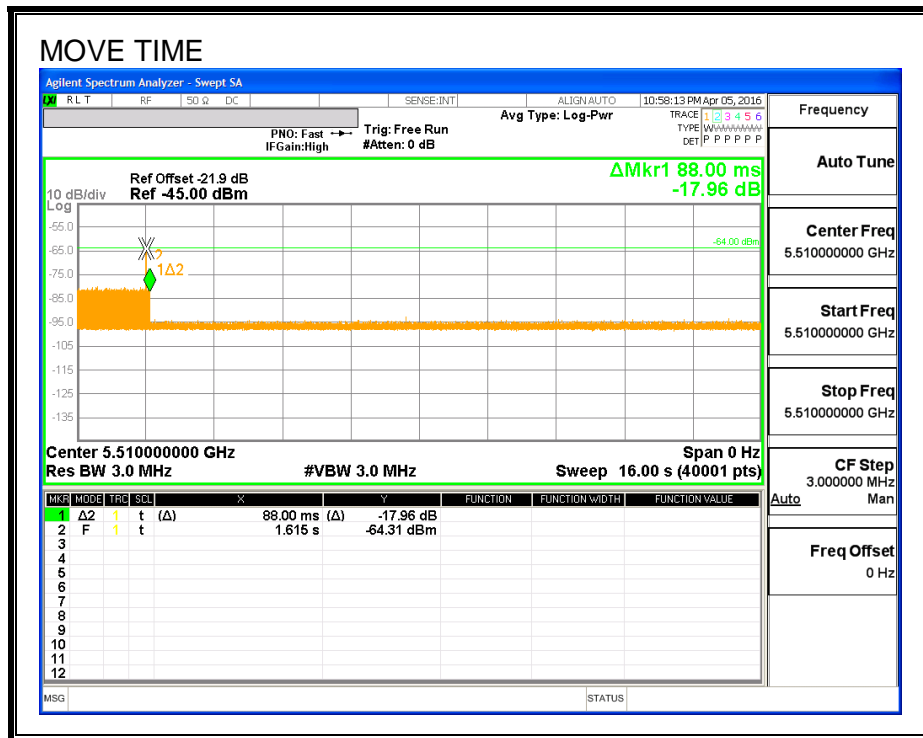

CHANNEL CLOSING TIME

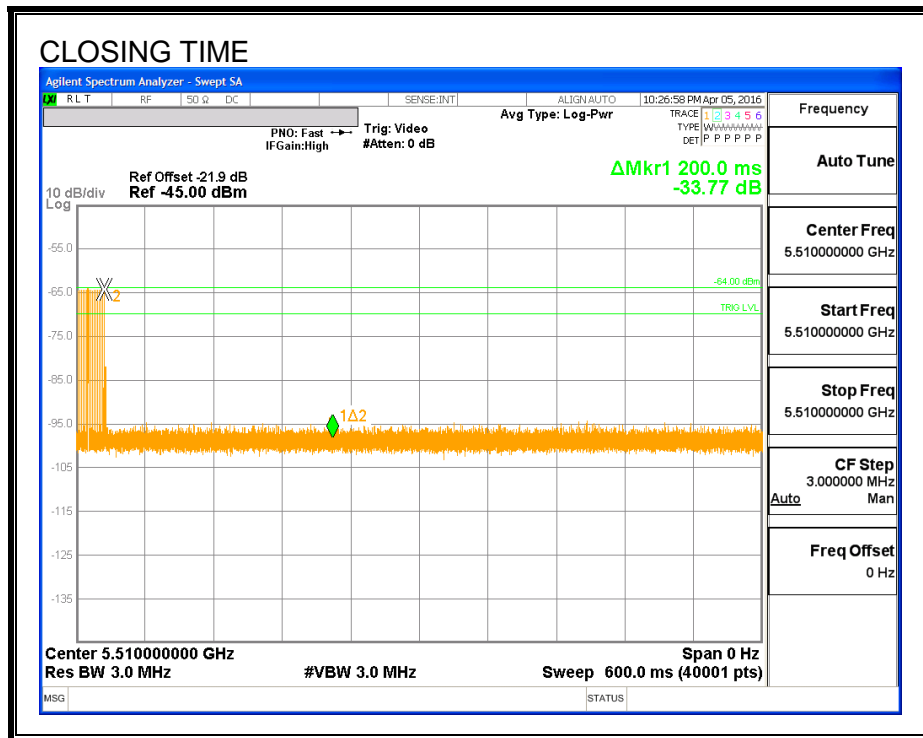

AGGREGATE CHANNEL CLOSING TRANSMISSION TIME

No transmissions are observed during the aggregate monitoring period.

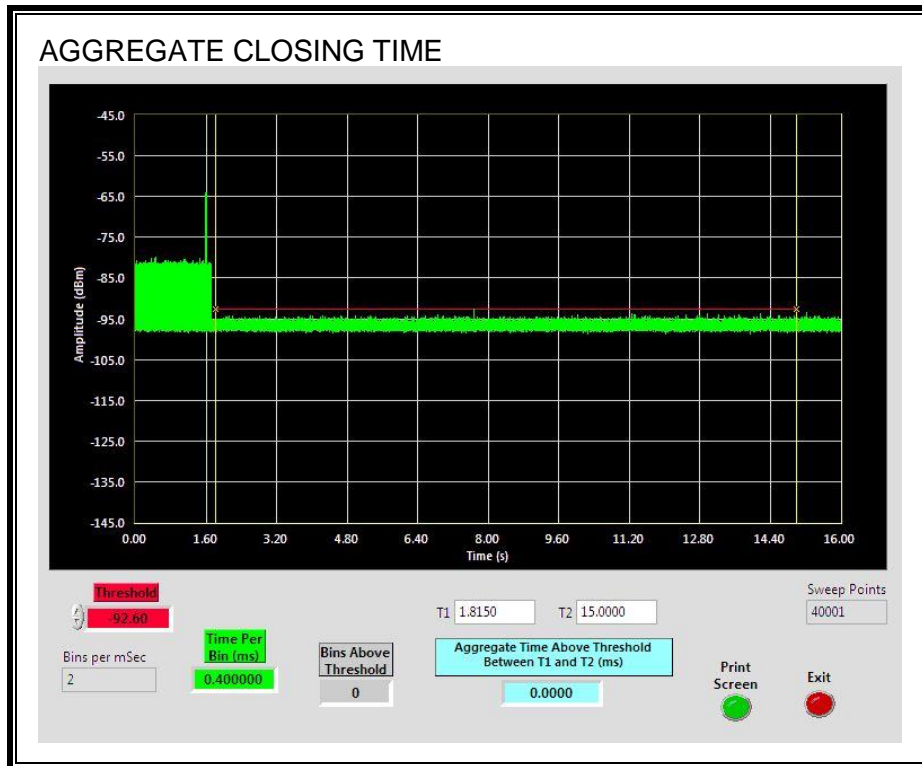

LONG PULSE CHANNEL MOVE TIME

The traffic ceases prior to 10 seconds after the end of the radar waveform.

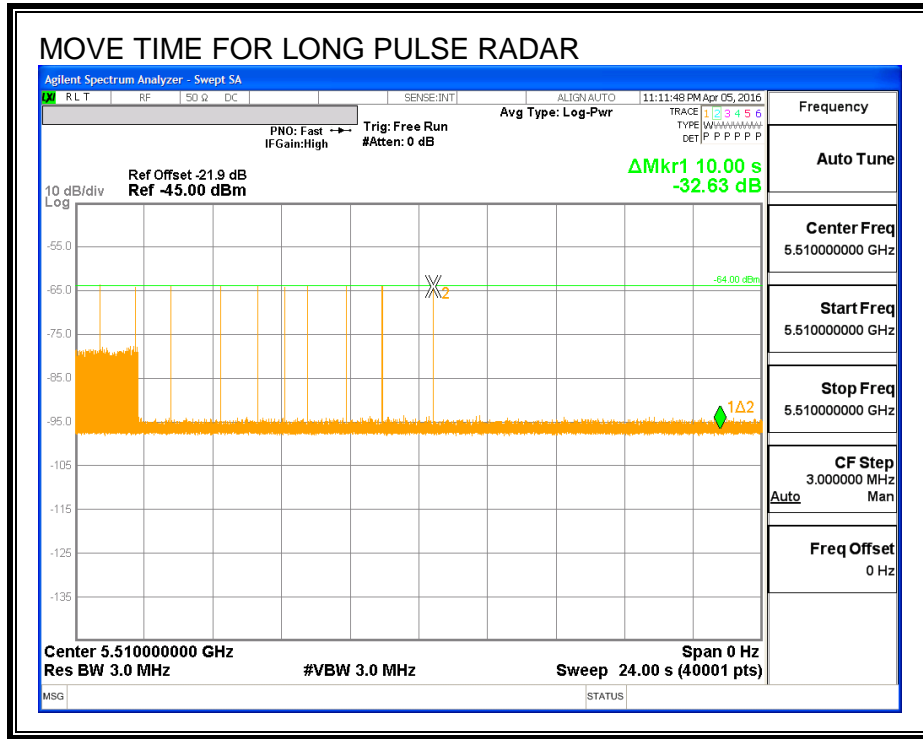

4.3.1. NON-OCCUPANCY PERIOD

RESULTS

No EUT transmissions were observed on the test channel during the 30-minute observation time.

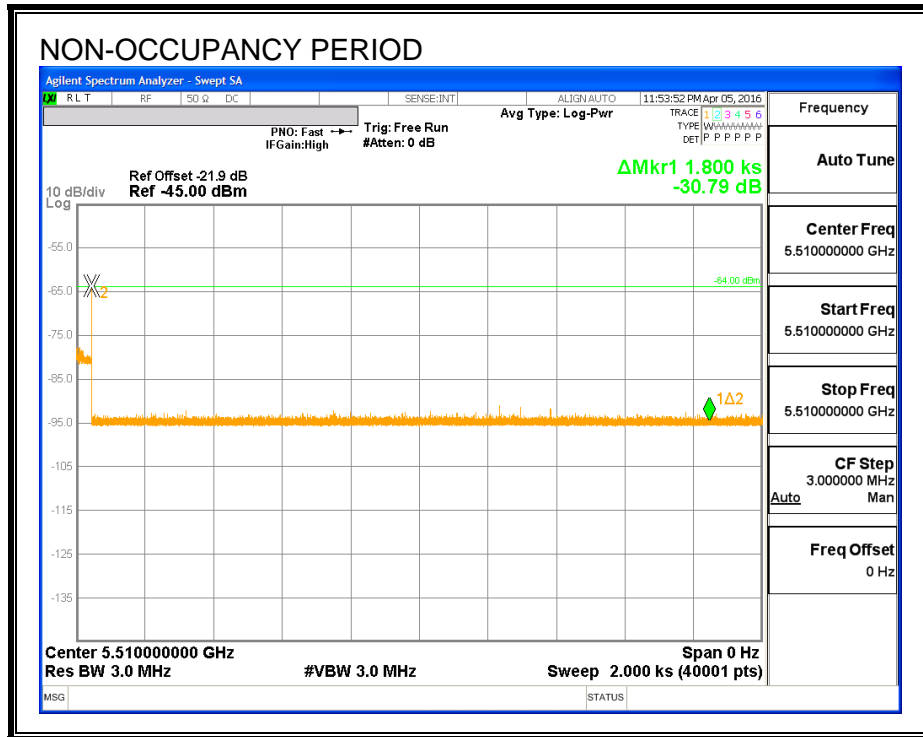

4.3.2. DETECTION BANDWIDTH

REFERENCE PLOT OF 99% POWER BANDWIDTH

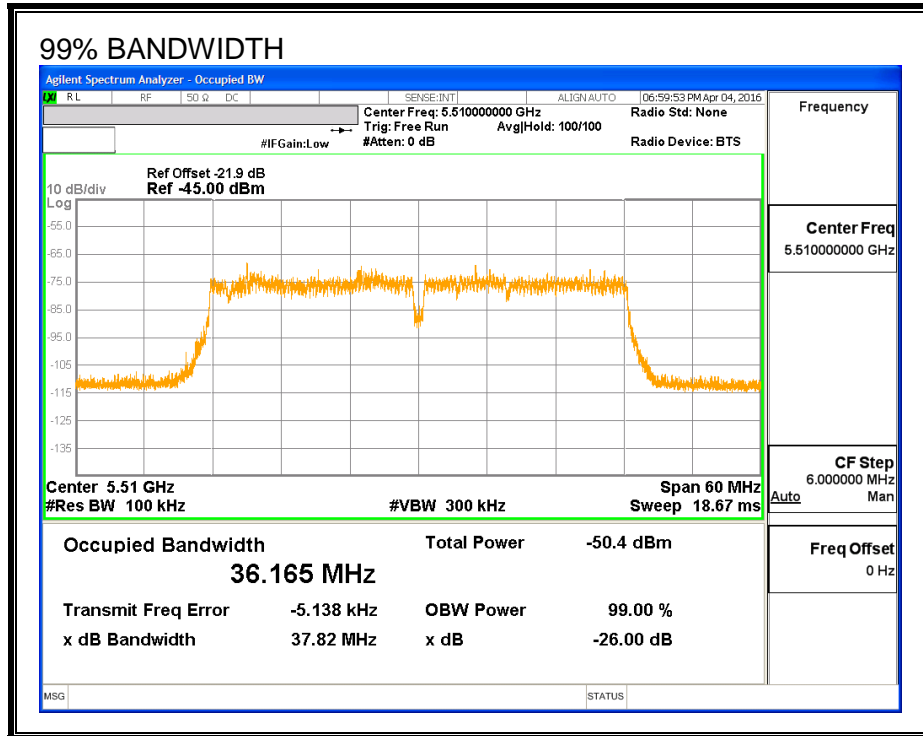

RESULTS

FL	FH	Detection Bandwidth	99% Power Bandwidth	Ratio of Detection BW to 99% Power BW	Minimum Limit
(MHz)	(MHz)	(MHz)	(MHz)	(%)	(%)
5491	5529	38	36.165	105.1	100

DETECTION BANDWIDTH PROBABILITY

DETECTION BANDWIDTH PROBABILITY RESULTS				
Detection Bandwidth Test Results				
FCC Type 0 Waveform: 1 us Pulse Width, 1428 us PRI, 18 Pulses per Burst				
Frequency (MHz)	Number of Trials	Number Detected	Detection (%)	Mark
5490	10	1	10	
5491	10	10	100	FL
5492	10	10	100	
5493	10	9	90	
5494	10	10	100	
5495	10	10	100	
5500	10	10	100	
5505	10	10	100	
5510	10	10	100	
5515	10	9	90	
5520	10	10	100	
5525	10	10	100	
5526	10	10	100	
5527	10	10	100	
5528	10	10	100	
5529	10	10	100	FH
5530	10	5	50	

4.3.3. IN-SERVICE MONITORING

RESULTS

FCC Radar Test Summary								
Signal Type	Number of Trials	Detection (%)	Limit (%)	Pass/Fail	Detection Bandwidth		80% of Det BW	
					FL	FH	FL5	FH5
FCC Short Pulse Type 1	30	100.00	60	Pass	5491	5529		
FCC Short Pulse Type 2	30	100.00	60	Pass	5491	5529		
FCC Short Pulse Type 3	30	100.00	60	Pass	5491	5529		
FCC Short Pulse Type 4	30	96.67	60	Pass	5491	5529		
Aggregate		99.17	80	Pass				
FCC Long Pulse Type 5	30	93.33	80	Pass	5491	5529	5495	5525
FCC Hopping Type 6	39	100.00	70	Pass	5491	5529		

TYPE 1 DETECTION PROBABILITY

Data Sheet for FCC Short Pulse Radar Type 1						
Waveform	Pulse Width (us)	PRI (us)	Pulses Per Burst	Test (A/B)	Frequency (MHz)	Successful Detection (Yes/No)
1001	1	3066	18	A	5510	Yes
1002	1	698	76	A	5510	Yes
1003	1	578	92	A	5510	Yes
1004	1	858	62	A	5510	Yes
1005	1	558	95	A	5510	Yes
1006	1	638	83	A	5510	Yes
1007	1	798	67	A	5510	Yes
1008	1	918	58	A	5510	Yes
1009	1	898	59	A	5510	Yes
1010	1	598	89	A	5510	Yes
1011	1	538	99	A	5510	Yes
1012	1	778	68	A	5510	Yes
1013	1	818	65	A	5510	Yes
1014	1	618	86	A	5510	Yes
1015	1	718	74	A	5510	Yes
1016	1	2395	23	B	5510	Yes
1017	1	1480	36	B	5510	Yes
1018	1	2242	24	B	5510	Yes
1019	1	1456	37	B	5510	Yes
1020	1	1153	46	B	5510	Yes
1021	1	1850	29	B	5510	Yes
1022	1	2871	19	B	5510	Yes
1023	1	2504	22	B	5510	Yes
1024	1	1583	34	B	5510	Yes
1025	1	2539	21	B	5510	Yes
1026	1	1429	37	B	5510	Yes
1027	1	1321	40	B	5510	Yes
1028	1	2889	19	B	5510	Yes
1029	1	2909	19	B	5510	Yes
1030	1	865	62	B	5510	Yes

TYPE 2 DETECTION PROBABILITY

Data Sheet for FCC Short Pulse Radar Type 2					
Waveform	Pulse Width (us)	PRI (us)	Pulses Per Burst	Frequency (MHz)	Successful Detection (Yes/No)
2001	4.6	169	26	5510	Yes
2002	2.8	212	28	5510	Yes
2003	3.7	206	27	5510	Yes
2004	2.1	215	26	5510	Yes
2005	1.2	213	29	5510	Yes
2006	2	226	28	5510	Yes
2007	3.3	190	28	5510	Yes
2008	2.4	208	24	5510	Yes
2009	1.9	219	29	5510	Yes
2010	3.1	159	25	5510	Yes
2011	1	174	29	5510	Yes
2012	4.6	162	23	5510	Yes
2013	2.6	181	25	5510	Yes
2014	2.3	173	29	5510	Yes
2015	4.7	158	27	5510	Yes
2016	2.7	154	25	5510	Yes
2017	3.3	225	24	5510	Yes
2018	1.5	187	26	5510	Yes
2019	2.4	224	29	5510	Yes
2020	4.9	190	24	5510	Yes
2021	4	230	27	5510	Yes
2022	4.8	201	26	5510	Yes
2023	4.2	165	23	5510	Yes
2024	1.1	182	29	5510	Yes
2025	4.7	193	26	5510	Yes
2026	4	214	23	5510	Yes
2027	3.8	230	24	5510	Yes
2028	3.3	217	28	5510	Yes
2029	1.3	156	29	5510	Yes
2030	1	228	27	5510	Yes

TYPE 3 DETECTION PROBABILITY

Data Sheet for FCC Short Pulse Radar Type 3					
Waveform	Pulse Width (us)	PRI (us)	Pulses Per Burst	Frequency (MHz)	Successful Detection (Yes/No)
3001	5.6	449	17	5510	Yes
3002	5.5	436	16	5510	Yes
3003	6.3	404	18	5510	Yes
3004	9.1	286	17	5510	Yes
3005	5.1	400	17	5510	Yes
3006	5.8	294	18	5510	Yes
3007	7.2	421	16	5510	Yes
3008	8.1	329	16	5510	Yes
3009	7.3	468	18	5510	Yes
3010	8.6	404	17	5510	Yes
3011	8	305	16	5510	Yes
3012	7.1	371	18	5510	Yes
3013	6.9	419	18	5510	Yes
3014	6.2	380	17	5510	Yes
3015	8.9	440	17	5510	Yes
3016	8.5	414	16	5510	Yes
3017	9.1	369	16	5510	Yes
3018	9	490	16	5510	Yes
3019	9.8	458	17	5510	Yes
3020	7.5	457	17	5510	Yes
3021	8.6	320	16	5510	Yes
3022	9.3	466	17	5510	Yes
3023	5.6	342	16	5510	Yes
3024	6.5	500	18	5510	Yes
3025	5.7	271	17	5510	Yes
3026	7	324	16	5510	Yes
3027	6.4	477	18	5510	Yes
3028	5.5	425	17	5510	Yes
3029	5.2	339	17	5510	Yes
3030	9.7	301	16	5510	Yes

TYPE 4 DETECTION PROBABILITY

Data Sheet for FCC Short Pulse Radar Type 4					
Waveform	Pulse Width (us)	PRI (us)	Pulses Per Burst	Frequency (MHz)	Successful Detection (Yes/No)
4001	14.6	361	13	5510	Yes
4002	19.2	468	16	5510	Yes
4003	15	290	15	5510	Yes
4004	20	410	16	5510	Yes
4005	16.3	378	15	5510	Yes
4006	11.8	260	12	5510	Yes
4007	14	492	16	5510	Yes
4008	15.4	387	15	5510	Yes
4009	18.1	262	15	5510	Yes
4010	20	303	14	5510	Yes
4011	18.4	442	12	5510	Yes
4012	10.7	496	12	5510	Yes
4013	19.8	397	12	5510	Yes
4014	18	346	12	5510	Yes
4015	17.4	260	13	5510	Yes
4016	16.2	472	16	5510	Yes
4017	11.4	415	12	5510	Yes
4018	16	389	12	5510	Yes
4019	11.8	462	14	5510	Yes
4020	16.9	331	15	5510	Yes
4021	13.1	299	14	5510	Yes
4022	18.7	432	15	5510	Yes
4023	16.2	412	15	5510	Yes
4024	12.2	307	14	5510	Yes
4025	14.9	434	13	5510	No
4026	16.8	475	13	5510	Yes
4027	15.2	363	15	5510	Yes
4028	17.6	417	15	5510	Yes
4029	16.6	318	16	5510	Yes
4030	14.8	267	15	5510	Yes

TYPE 5 DETECTION PROBABILITY

Data Sheet for FCC Long Pulse Radar Type 5		
Trial	Frequency (MHz)	Successful Detection (Yes/No)
1	5503	Yes
2	5496	Yes
3	5504	Yes
4	5503	Yes
5	5519	Yes
6	5507	Yes
7	5499	Yes
8	5512	Yes
9	5503	Yes
10	5506	Yes
11	5497	Yes
12	5522	Yes
13	5519	Yes
14	5518	Yes
15	5524	Yes
16	5504	Yes
17	5506	No
18	5505	Yes
19	5501	Yes
20	5513	Yes
21	5513	Yes
22	5505	No
23	5512	Yes
24	5520	Yes
25	5518	Yes
26	5496	Yes
27	5514	Yes
28	5524	Yes
29	5523	Yes
30	5508	Yes

Note: The Type 5 randomized parameters tested are shown in a separate document.

TYPE 6 DETECTION PROBABILITY

Data Sheet for FCC Hopping Radar Type 6				
1 us Pulse Width, 333 us PRI, 9 Pulses per Burst, 1 Burst per Hop				
NTIA August 2005 Hopping Sequence				
Trial	Starting Index Within Sequence	Signal Generator Frequency (MHz)	Hops within Detection BW	Successful Detection (Yes/No)
1	53	5491	9	Yes
2	528	5492	5	Yes
3	1003	5493	6	Yes
4	1478	5494	11	Yes
5	1953	5495	14	Yes
6	2428	5496	7	Yes
7	2903	5497	7	Yes
8	3378	5498	8	Yes
9	3853	5499	11	Yes
10	4328	5500	7	Yes
11	4803	5501	10	Yes
12	5278	5502	8	Yes
13	5753	5503	8	Yes
14	6228	5504	10	Yes
15	6703	5505	7	Yes
16	7178	5506	9	Yes
17	7653	5507	9	Yes
18	8128	5508	5	Yes
19	8603	5509	6	Yes
20	9078	5510	10	Yes
21	9553	5511	9	Yes
22	10028	5512	8	Yes
23	10503	5513	6	Yes
24	10978	5514	6	Yes
25	11453	5515	7	Yes
26	11928	5516	10	Yes
27	12403	5517	8	Yes
28	12878	5518	9	Yes
29	13353	5519	14	Yes
30	13828	5520	6	Yes
31	14303	5521	8	Yes
32	14778	5522	6	Yes
33	15253	5523	10	Yes
34	15728	5524	9	Yes
35	16203	5525	10	Yes
36	16678	5526	4	Yes
37	17153	5527	10	Yes
38	17628	5528	12	Yes
39	18103	5529	8	Yes

4.4. RESULTS FOR 80 MHz BANDWIDTH

4.4.1. TEST CHANNEL

All tests were performed at a channel center frequency of 5530 MHz.

4.4.2. RADAR WAVEFORMS AND TRAFFIC

RADAR WAVEFORMS

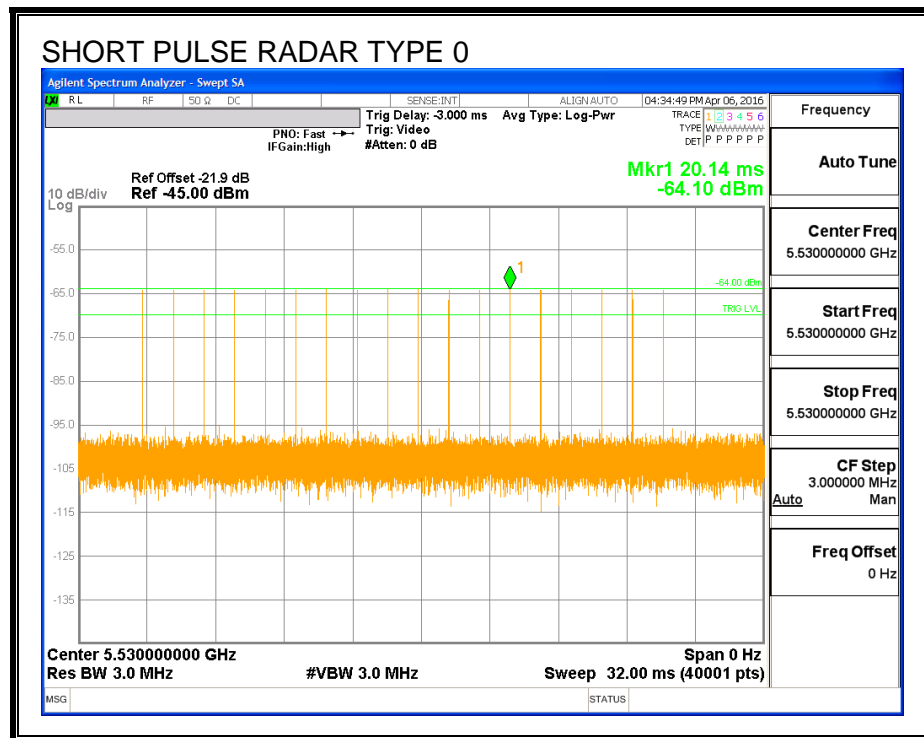

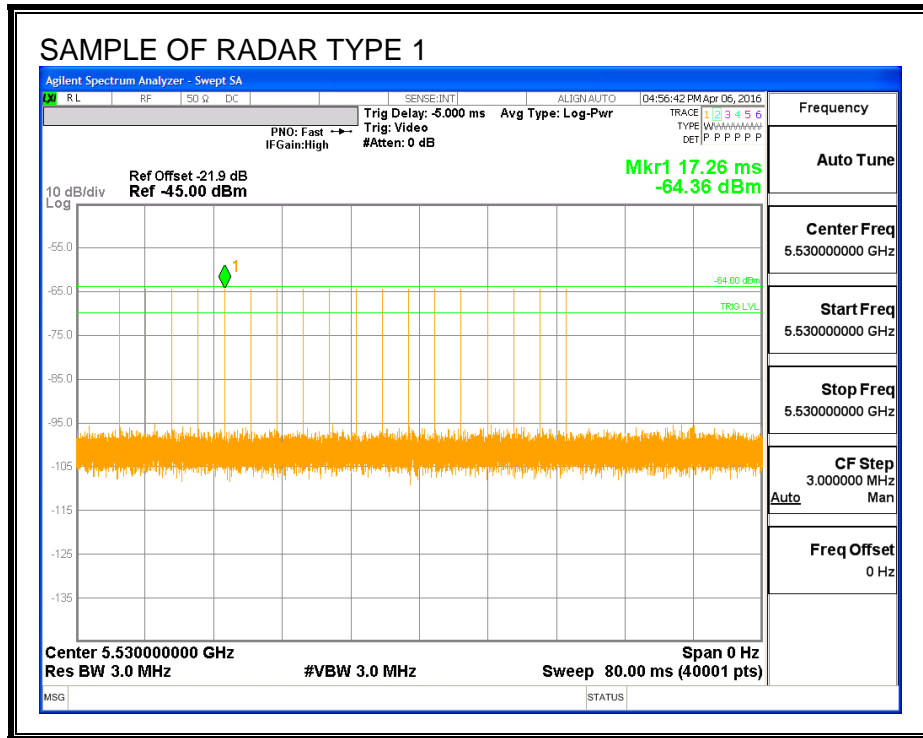

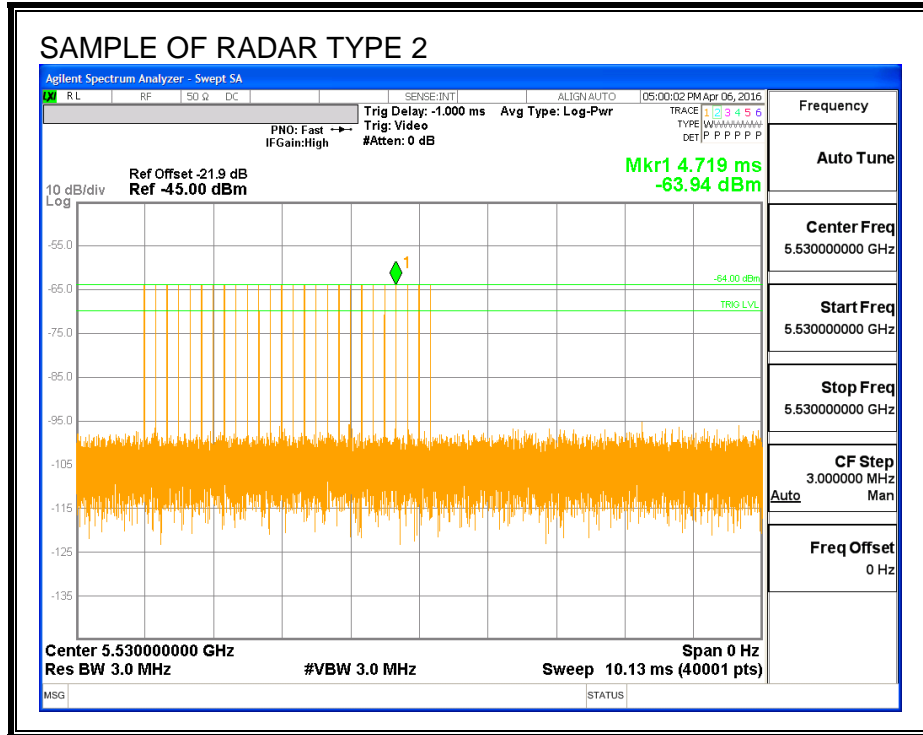

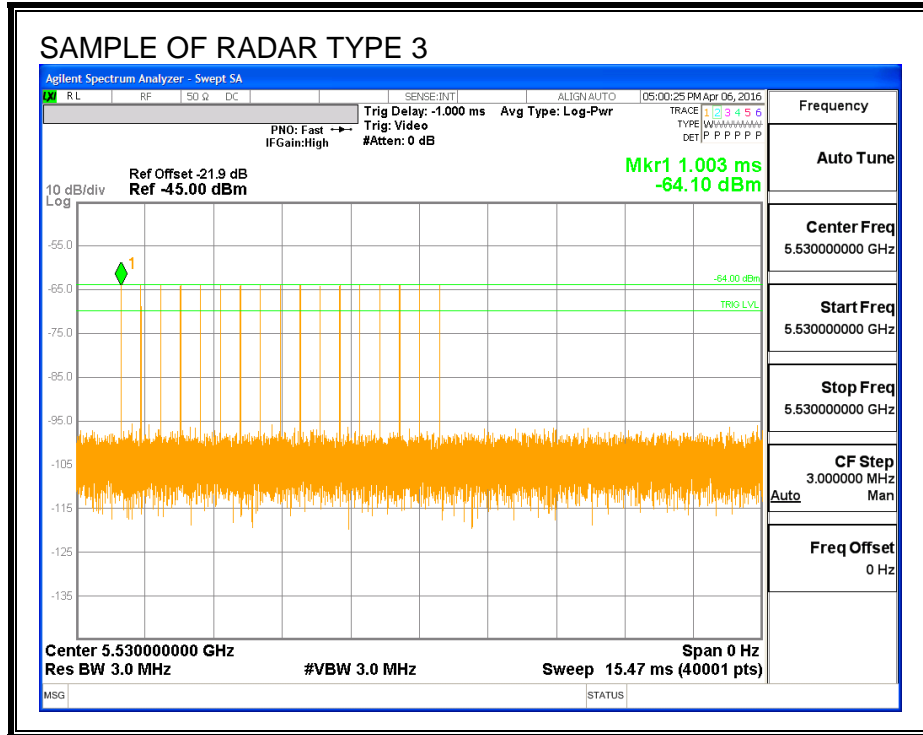

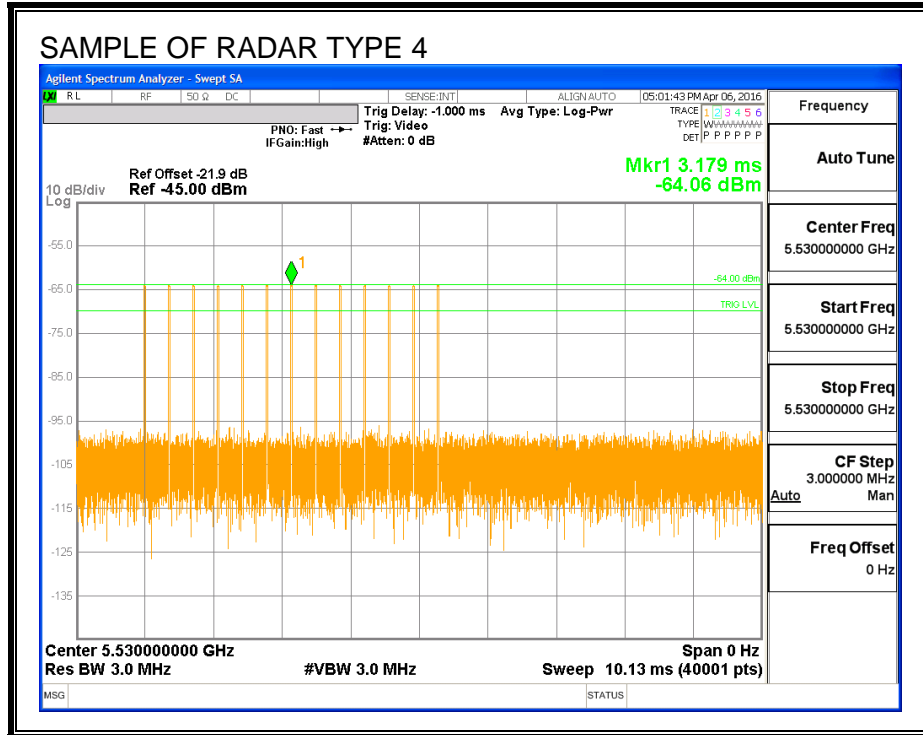

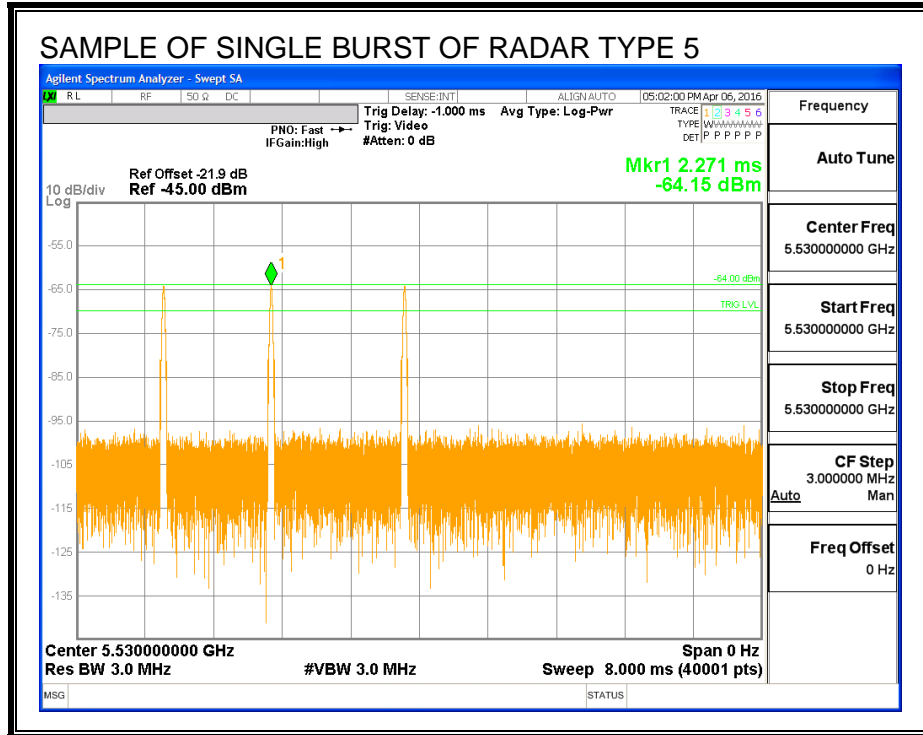

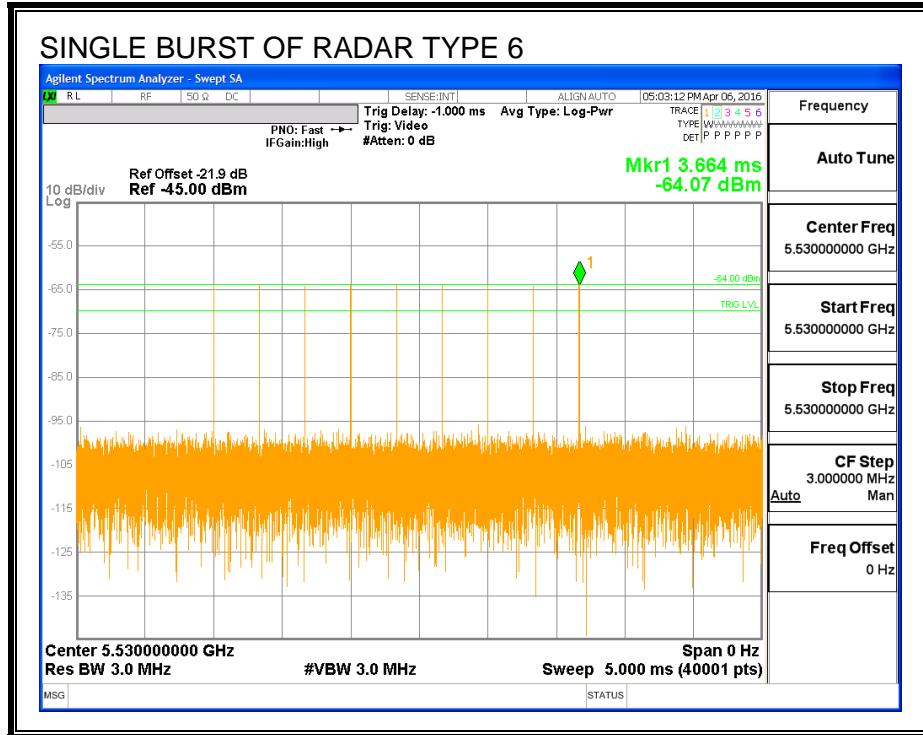

TRAFFIC

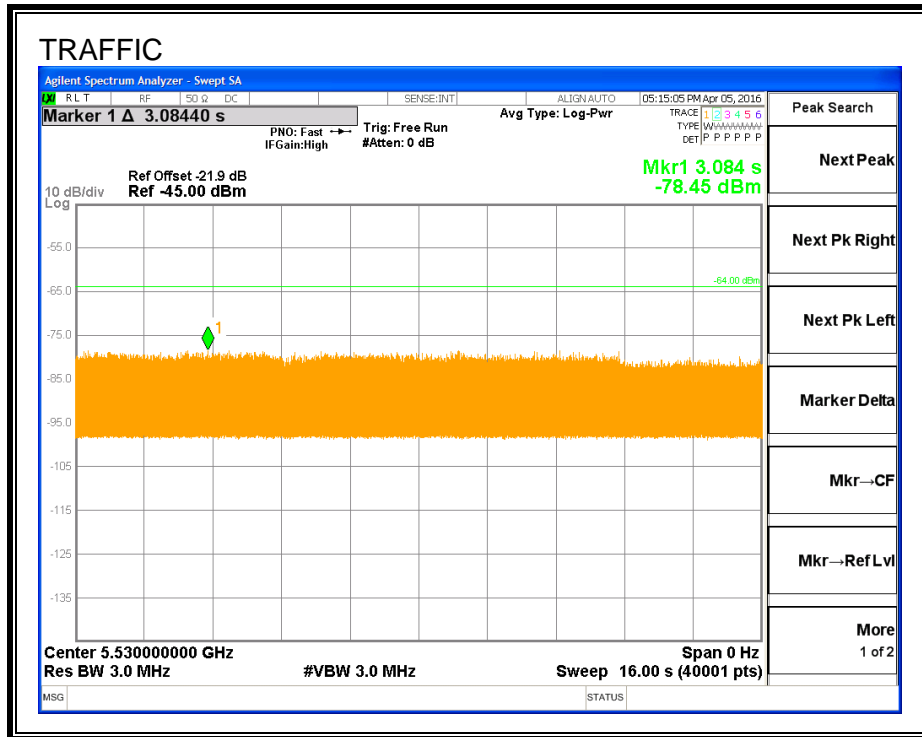

CHANNEL LOADING

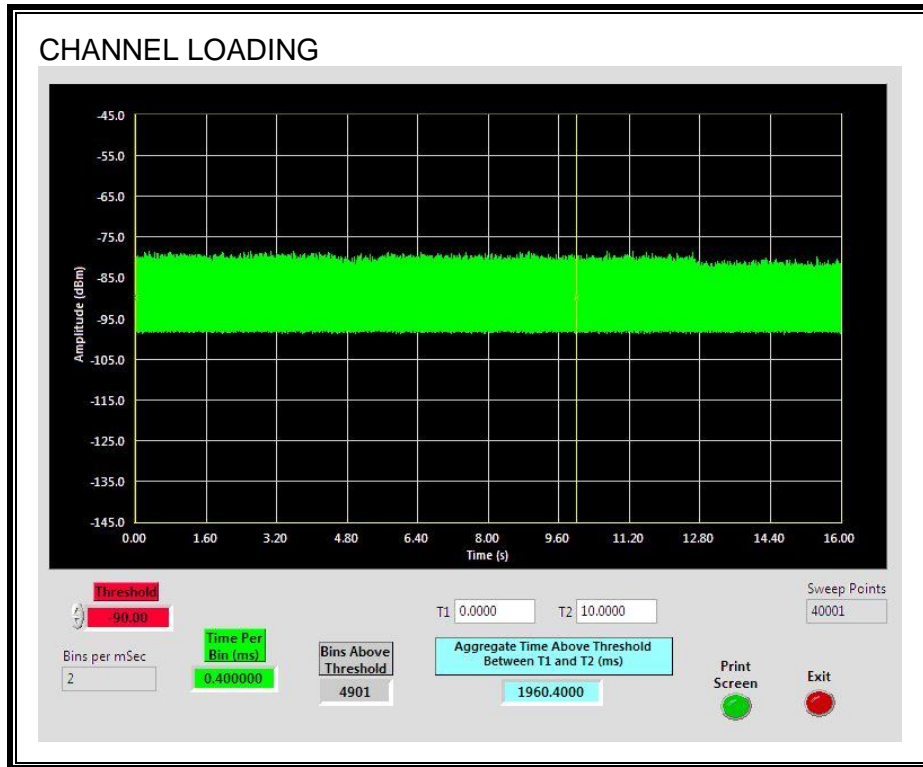

The level of traffic loading on the channel by the EUT is 19.604%%

4.4.1. CHANNEL AVAILABILITY CHECK TIME

PROCEDURE TO DETERMINE INITIAL POWER-UP CYCLE TIME

A link was established on channel then the EUT was rebooted. The time from the cessation of traffic to the re-initialization of traffic was measured as the time required for the EUT to complete the total power-up cycle. The time to complete the initial power-up period is 60 seconds less than this total power-up time.

PROCEDURE FOR TIMING OF RADAR BURST

With a link established on channel, the EUT was rebooted. A radar signal was triggered within 0 to 6 seconds after the initial power-up period, and transmissions on the channel were monitored on the spectrum analyzer.

The Non-Occupancy list was cleared. With a link established on channel, the EUT was rebooted. A radar signal was triggered within 54 to 60 seconds after the initial power-up period, and transmissions on the channel were monitored on the spectrum analyzer.

QUANTITATIVE RESULTS

No Radar Triggered

Timing of Reboot (sec)	Timing of Start of Traffic (sec)	Total Power-up Cycle Time (sec)	Initial Power-up Cycle Time (sec)
30.07	141.7	111.6	51.6

Radar Near Beginning of CAC

Timing of Reboot (sec)	Timing of Radar Burst (sec)	Radar Relative to Reboot (sec)	Radar Relative to Start of CAC (sec)
30.21	82.9	52.6	1.0

Radar Near End of CAC

Timing of Reboot (sec)	Timing of Radar Burst (sec)	Radar Relative to Reboot (sec)	Radar Relative to Start of CAC (sec)
30.19	140.5	110.3	58.7

QUALITATIVE RESULTS

Timing of Radar Burst	Display on Control Computer	Spectrum Analyzer Display
No Radar Triggered	EUT marks Channel as active	Transmissions begin on channel after completion of the initial power-up cycle and the CAC
Within 0 to 6 second window	EUT indicates radar detected	No transmissions on channel
Within 54 to 60 second window	EUT indicates radar detected	No transmissions on channel

TIMING WITHOUT RADAR DURING CAC

AP is rebooted
 Traffic ceases
 Start of Initial Power-up cycle

End of Initial Power-up cycle
 Start of CAC

End of CAC
 Traffic is Initiated

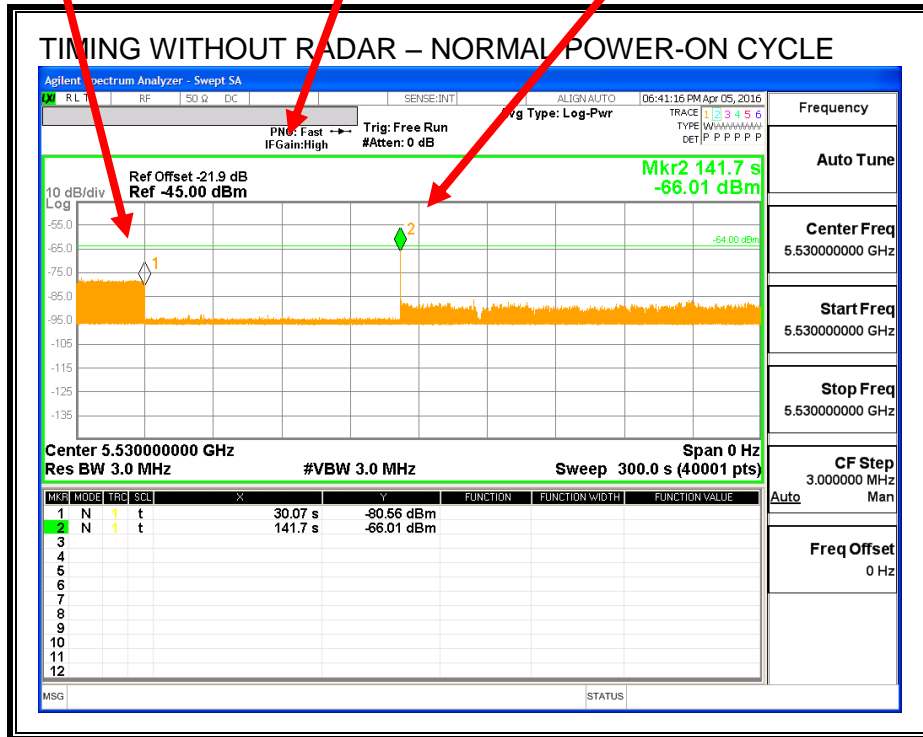

Transmissions begin on channel after completion of the initial power-up cycle and the CAC.

TIMING WITH RADAR NEAR BEGINNING OF CAC

AP is rebooted
 Traffic ceases
 Start of Initial Power-up cycle

End of Initial Power-up cycle
 Start of CAC

Radar Signal Applied

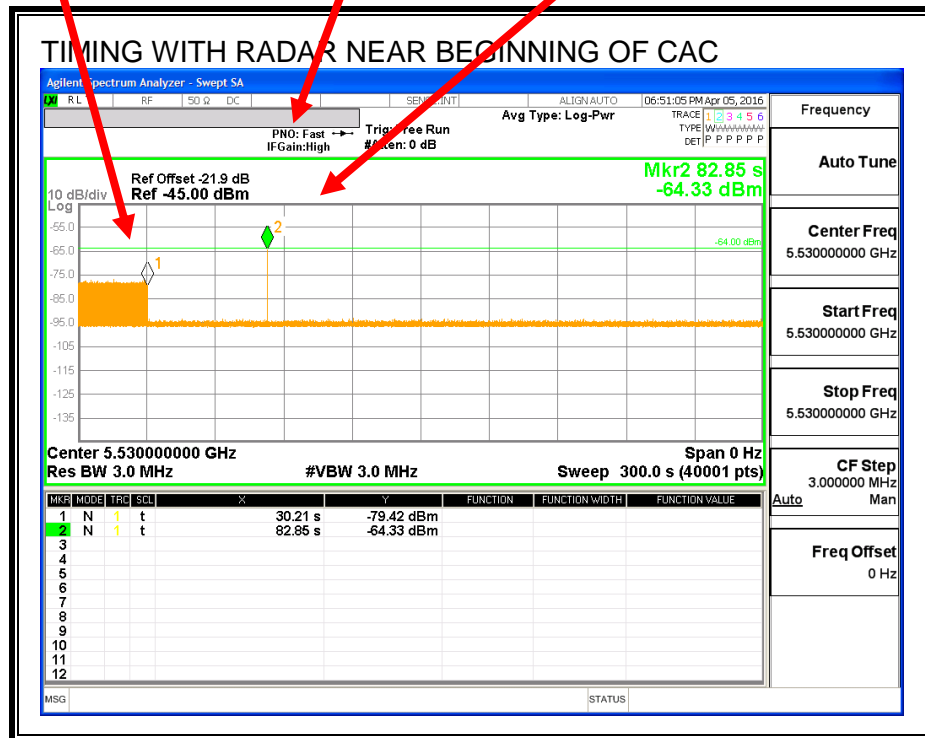

No EUT transmissions were observed after the radar signal.

TIMING WITH RADAR NEAR END OF CAC

AP is rebooted
 Traffic ceases
 Start of Initial Power-up cycle

End of Initial Power-up cycle
 Start of CAC

Radar Signal Applied

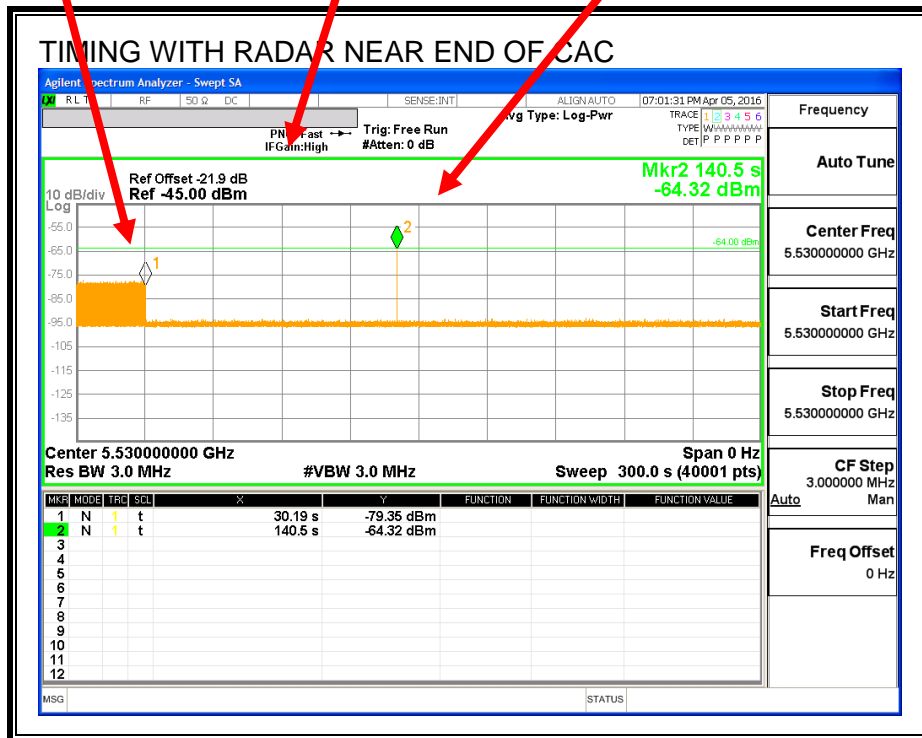

No EUT transmissions were observed after the radar signal.

4.4.2. OVERLAPPING CHANNEL TESTS

RESULTS

The channel spacing is not less than the channel bandwidth therefore the EUT does not have an overlapping channel plan.

These tests are not applicable.

4.4.3. MOVE AND CLOSING TIME

REPORTING NOTES

The reference marker is set at the end of last radar pulse.

The delta marker is set at the end of the last WLAN transmission following the radar pulse. This delta is the channel move time.

The aggregate channel closing transmission time is calculated as follows:

Aggregate Transmission Time =
(Number of analyzer bins showing transmission) * (dwell time per bin)

The observation period over which the aggregate time is calculated begins at (Reference Marker + 200 msec) and ends no earlier than (Reference Marker + 10 sec).

RESULTS

Channel Move Time (sec)	Limit (sec)
0.000	10

Aggregate Channel Closing Transmission Time (msec)	Limit (msec)
0.0	60

MOVE TIME

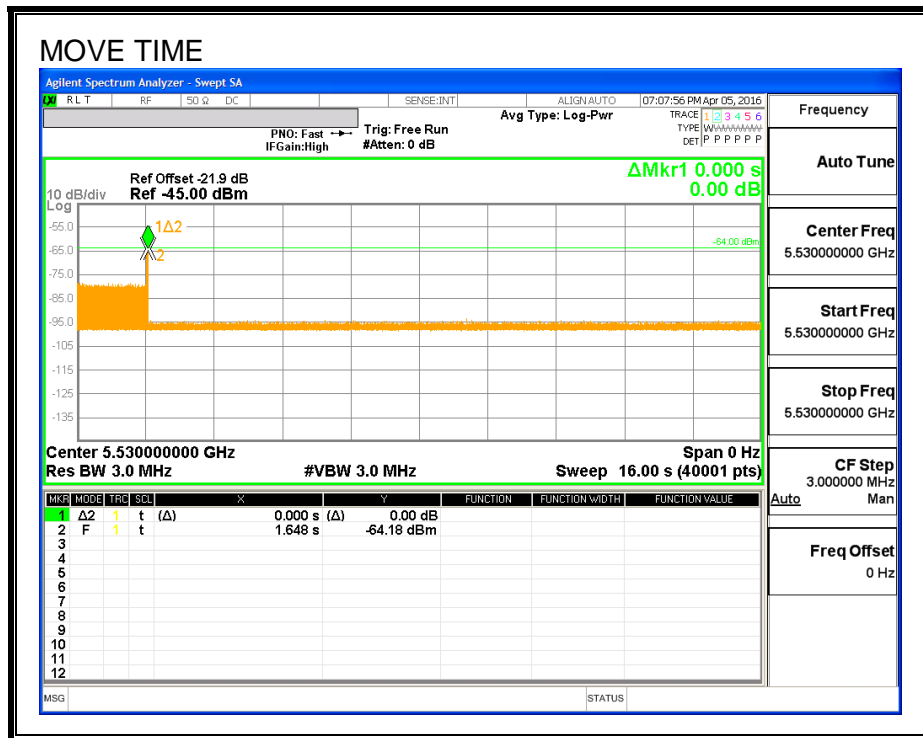

CHANNEL CLOSING TIME

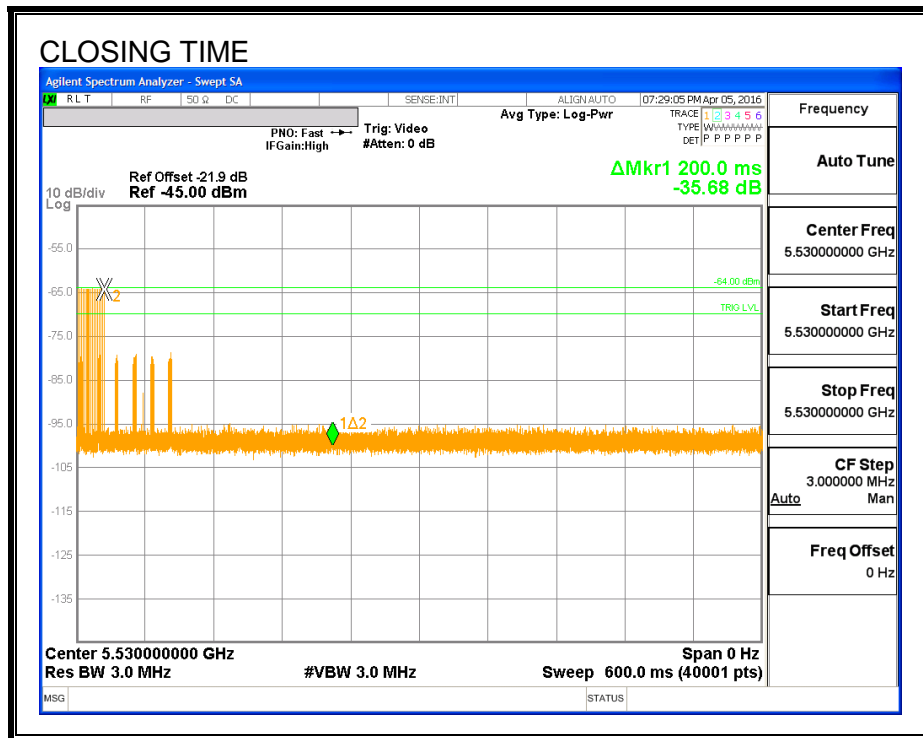

AGGREGATE CHANNEL CLOSING TRANSMISSION TIME

No transmissions are observed during the aggregate monitoring period.

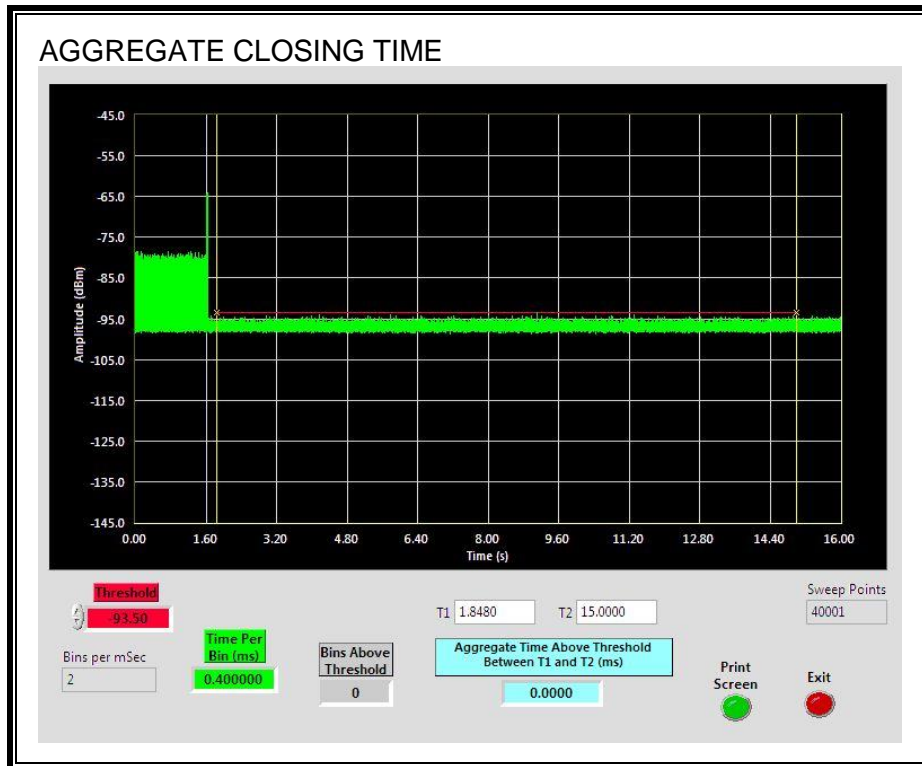

LONG PULSE CHANNEL MOVE TIME

The traffic ceases prior to 10 seconds after the end of the radar waveform.

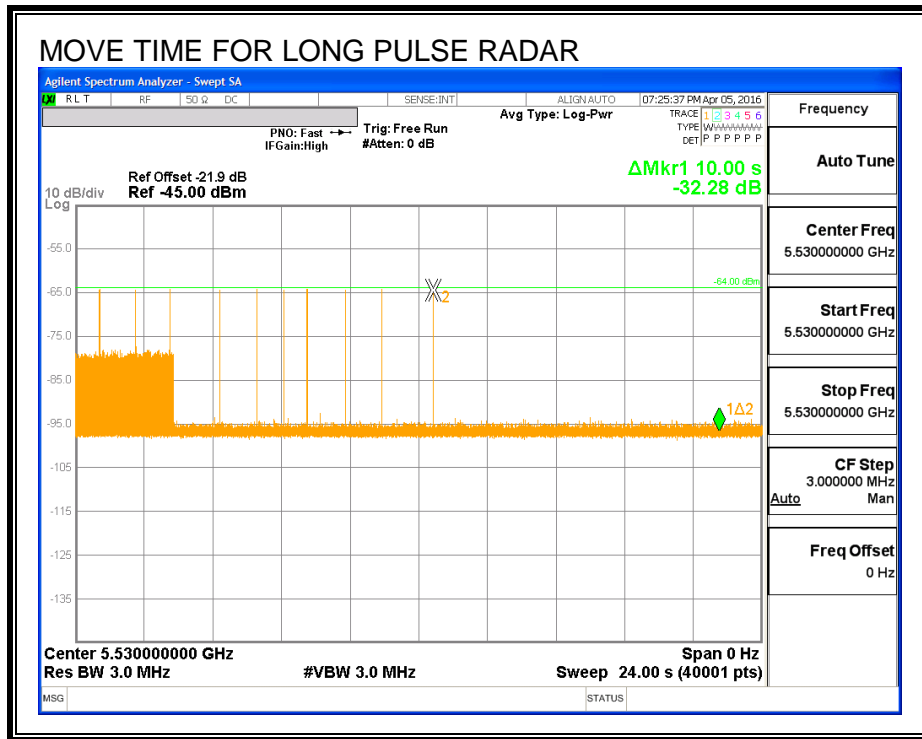

4.4.1. NON-OCCUPANCY PERIOD

RESULTS

No EUT transmissions were observed on the test channel during the 30-minute observation time.

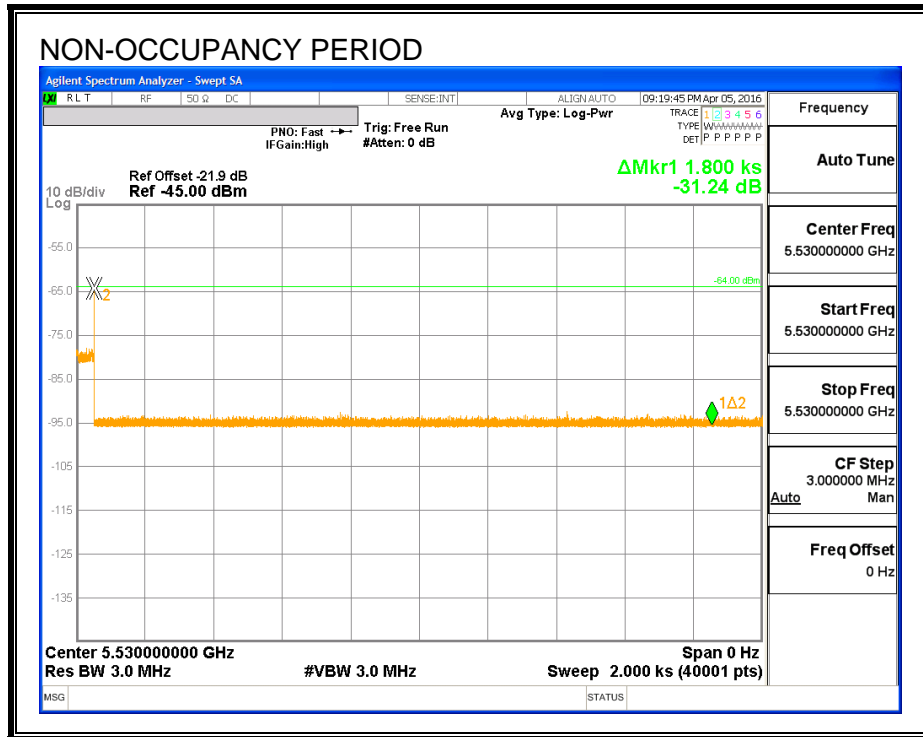

4.4.2. DETECTION BANDWIDTH

REFERENCE PLOT OF 99% POWER BANDWIDTH

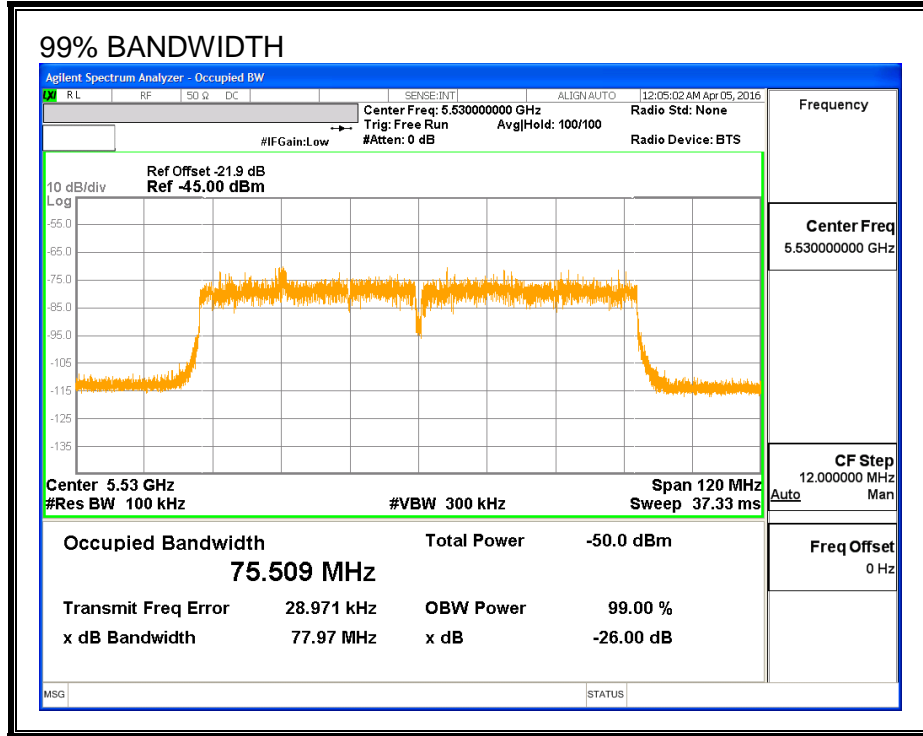

RESULTS

FL	FH	Detection Bandwidth	99% Power Bandwidth	Ratio of Detection BW to 99% Power BW	Minimum Limit
(MHz)	(MHz)	(MHz)	(MHz)	(%)	(%)
5491	5569	78	75.509	103.3	100

DETECTION BANDWIDTH PROBABILITY

DETECTION BANDWIDTH PROBABILITY RESULTS				
Detection Bandwidth Test Results				
FCC Type 0 Waveform: 1 us Pulse Width, 1428 us PRI, 18 Pulses per Burst				
Frequency (MHz)	Number of Trials	Number Detected	Detection (%)	Mark
5490	10	0	0	
5491	10	10	100	FL
5492	10	10	100	
5493	10	10	100	
5494	10	10	100	
5495	10	10	100	
5500	10	10	100	
5505	10	10	100	
5510	10	10	100	
5515	10	10	100	
5520	10	10	100	
5525	10	10	100	
5530	10	10	100	
5535	10	10	100	
5540	10	10	100	
5545	10	10	100	
5550	10	10	100	
5555	10	10	100	
5560	10	10	100	
5565	10	10	100	
5566	10	10	100	
5567	10	10	100	
5568	10	10	100	
5569	10	10	100	FH
5570	10	0	0	

4.4.3. IN-SERVICE MONITORING

RESULTS

FCC Radar Test Summary								
Signal Type	Number of Trials	Detection (%)	Limit (%)	Pass/Fail	Detection Bandwidth		80% of Det BW	
					FL	FH	FL5	FH5
FCC Short Pulse Type 1	30	100.00	60	Pass	5491	5569		
FCC Short Pulse Type 2	30	70.00	60	Pass	5491	5569		
FCC Short Pulse Type 3	30	90.00	60	Pass	5491	5569		
FCC Short Pulse Type 4	30	93.33	60	Pass	5491	5569		
Aggregate		88.33	80	Pass				
FCC Long Pulse Type 5	30	93.33	80	Pass	5491	5569	5499	5561
FCC Hopping Type 6	79	100.00	70	Pass	5491	5569		

TYPE 1 DETECTION PROBABILITY

Data Sheet for FCC Short Pulse Radar Type 1						
Waveform	Pulse Width (us)	PRI (us)	Pulses Per Burst	Test (A/B)	Frequency (MHz)	Successful Detection (Yes/No)
1001	1	3066	18	A	5530	Yes
1002	1	698	76	A	5530	Yes
1003	1	578	92	A	5530	Yes
1004	1	858	62	A	5530	Yes
1005	1	558	95	A	5530	Yes
1006	1	638	83	A	5530	Yes
1007	1	798	67	A	5530	Yes
1008	1	918	58	A	5530	Yes
1009	1	898	59	A	5530	Yes
1010	1	598	89	A	5530	Yes
1011	1	538	99	A	5530	Yes
1012	1	778	68	A	5530	Yes
1013	1	818	65	A	5530	Yes
1014	1	618	86	A	5530	Yes
1015	1	718	74	A	5530	Yes
1016	1	2395	23	B	5530	Yes
1017	1	1480	36	B	5530	Yes
1018	1	2242	24	B	5530	Yes
1019	1	1456	37	B	5530	Yes
1020	1	1153	46	B	5530	Yes
1021	1	1850	29	B	5530	Yes
1022	1	2871	19	B	5530	Yes
1023	1	2504	22	B	5530	Yes
1024	1	1583	34	B	5530	Yes
1025	1	2539	21	B	5530	Yes
1026	1	1429	37	B	5530	Yes
1027	1	1321	40	B	5530	Yes
1028	1	2889	19	B	5530	Yes
1029	1	2909	19	B	5530	Yes
1030	1	865	62	B	5530	Yes

TYPE 2 DETECTION PROBABILITY

Data Sheet for FCC Short Pulse Radar Type 2					
Waveform	Pulse Width (us)	PRI (us)	Pulses Per Burst	Frequency (MHz)	Successful Detection (Yes/No)
2001	4.6	169	26	5530	No
2002	2.8	212	28	5530	No
2003	3.7	206	27	5530	Yes
2004	2.1	215	26	5530	No
2005	1.2	213	29	5530	Yes
2006	2	226	28	5530	No
2007	3.3	190	28	5530	Yes
2008	2.4	208	24	5530	No
2009	1.9	219	29	5530	No
2010	3.1	159	25	5530	Yes
2011	1	174	29	5530	Yes
2012	4.6	162	23	5530	Yes
2013	2.6	181	25	5530	Yes
2014	2.3	173	29	5530	Yes
2015	4.7	158	27	5530	Yes
2016	2.7	154	25	5530	No
2017	3.3	225	24	5530	Yes
2018	1.5	187	26	5530	Yes
2019	2.4	224	29	5530	No
2020	4.9	190	24	5530	No
2021	4	230	27	5530	Yes
2022	4.8	201	26	5530	Yes
2023	4.2	165	23	5530	Yes
2024	1.1	182	29	5530	Yes
2025	4.7	193	26	5530	Yes
2026	4	214	23	5530	Yes
2027	3.8	230	24	5530	Yes
2028	3.3	217	28	5530	Yes
2029	1.3	156	29	5530	Yes
2030	1	228	27	5530	Yes

TYPE 3 DETECTION PROBABILITY

Data Sheet for FCC Short Pulse Radar Type 3					
Waveform	Pulse Width (us)	PRI (us)	Pulses Per Burst	Frequency (MHz)	Successful Detection (Yes/No)
3001	5.6	449	17	5530	Yes
3002	5.5	436	16	5530	Yes
3003	6.3	404	18	5530	No
3004	9.1	286	17	5530	No
3005	5.1	400	17	5530	No
3006	5.8	294	18	5530	Yes
3007	7.2	421	16	5530	Yes
3008	8.1	329	16	5530	Yes
3009	7.3	468	18	5530	Yes
3010	8.6	404	17	5530	Yes
3011	8	305	16	5530	Yes
3012	7.1	371	18	5530	Yes
3013	6.9	419	18	5530	Yes
3014	6.2	380	17	5530	Yes
3015	8.9	440	17	5530	Yes
3016	8.5	414	16	5530	Yes
3017	9.1	369	16	5530	Yes
3018	9	490	16	5530	Yes
3019	9.8	458	17	5530	Yes
3020	7.5	457	17	5530	Yes
3021	8.6	320	16	5530	Yes
3022	9.3	466	17	5530	Yes
3023	5.6	342	16	5530	Yes
3024	6.5	500	18	5530	Yes
3025	5.7	271	17	5530	Yes
3026	7	324	16	5530	Yes
3027	6.4	477	18	5530	Yes
3028	5.5	425	17	5530	Yes
3029	5.2	339	17	5530	Yes
3030	9.7	301	16	5530	Yes

TYPE 4 DETECTION PROBABILITY

Data Sheet for FCC Short Pulse Radar Type 4					
Waveform	Pulse Width (us)	PRI (us)	Pulses Per Burst	Frequency (MHz)	Successful Detection (Yes/No)
4001	14.6	361	13	5530	Yes
4002	19.2	468	16	5530	Yes
4003	15	290	15	5530	Yes
4004	20	410	16	5530	Yes
4005	16.3	378	15	5530	Yes
4006	11.8	260	12	5530	No
4007	14	492	16	5530	Yes
4008	15.4	387	15	5530	Yes
4009	18.1	262	15	5530	Yes
4010	20	303	14	5530	Yes
4011	18.4	442	12	5530	Yes
4012	10.7	496	12	5530	Yes
4013	19.8	397	12	5530	Yes
4014	18	346	12	5530	Yes
4015	17.4	260	13	5530	Yes
4016	16.2	472	16	5530	Yes
4017	11.4	415	12	5530	No
4018	16	389	12	5530	Yes
4019	11.8	462	14	5530	Yes
4020	16.9	331	15	5530	Yes
4021	13.1	299	14	5530	Yes
4022	18.7	432	15	5530	Yes
4023	16.2	412	15	5530	Yes
4024	12.2	307	14	5530	Yes
4025	14.9	434	13	5530	Yes
4026	16.8	475	13	5530	Yes
4027	15.2	363	15	5530	Yes
4028	17.6	417	15	5530	Yes
4029	16.6	318	16	5530	Yes
4030	14.8	267	15	5530	Yes

TYPE 5 DETECTION PROBABILITY

Data Sheet for FCC Long Pulse Radar Type 5		
Trial	Frequency (MHz)	Successful Detection (Yes/No)
1	5522	No
2	5522	Yes
3	5521	Yes
4	5528	Yes
5	5542	Yes
6	5521	Yes
7	5511	Yes
8	5529	Yes
9	5541	Yes
10	5517	Yes
11	5519	Yes
12	5530	Yes
13	5529	Yes
14	5512	Yes
15	5536	Yes
16	5553	Yes
17	5528	Yes
18	5553	Yes
19	5534	Yes
20	5559	Yes
21	5529	Yes
22	5550	Yes
23	5552	Yes
24	5500	Yes
25	5515	Yes
26	5542	Yes
27	5529	Yes
28	5542	Yes
29	5524	No
30	5544	Yes

Note: The Type 5 randomized parameters tested are shown in a separate document.

TYPE 6 DETECTION PROBABILITY

Data Sheet for FCC Hopping Radar Type 6				
1 us Pulse Width, 333 us PRI, 9 Pulses per Burst, 1 Burst per Hop				
NTIA August 2005 Hopping Sequence				
Trial	Starting Index Within Sequence	Signal Generator Frequency (MHz)	Hops within Detection BW	Successful Detection (Yes/No)
1	230	5491	22	Yes
2	705	5492	14	Yes
3	1180	5493	20	Yes
4	1655	5494	11	Yes
5	2130	5495	15	Yes
6	2605	5496	14	Yes
7	3080	5497	19	Yes
8	3555	5498	14	Yes
9	4030	5499	16	Yes
10	4505	5500	20	Yes
11	4980	5501	17	Yes
12	5455	5502	24	Yes
13	5930	5503	19	Yes
14	6405	5504	16	Yes
15	6880	5505	19	Yes
16	7355	5506	17	Yes
17	7830	5507	28	Yes
18	8305	5508	15	Yes
19	8780	5509	14	Yes
20	9255	5510	16	Yes
21	9730	5511	23	Yes
22	10205	5512	16	Yes
23	10680	5513	14	Yes
24	11155	5514	19	Yes
25	11630	5515	22	Yes
26	12105	5516	16	Yes
27	12580	5517	16	Yes
28	13055	5518	12	Yes
29	13530	5519	15	Yes
30	14005	5520	16	Yes
31	14480	5521	23	Yes
32	14955	5522	14	Yes
33	15430	5523	17	Yes
34	15905	5524	15	Yes

TYPE 6 DETECTION PROBABILITY (CONTINUED)

35	16380	5525	20	Yes
36	16855	5526	20	Yes
37	17330	5527	15	Yes
38	17805	5528	21	Yes
39	18280	5529	13	Yes
40	18755	5530	13	Yes
41	19230	5531	15	Yes
42	19705	5532	23	Yes
43	20180	5533	18	Yes
44	20655	5534	22	Yes
45	21130	5535	12	Yes
46	21605	5536	19	Yes
47	22080	5537	20	Yes
48	22555	5538	20	Yes
49	23030	5539	20	Yes
50	23505	5540	21	Yes
51	23980	5541	14	Yes
52	24455	5542	7	Yes
53	24930	5543	13	Yes
54	25405	5544	15	Yes
55	25880	5545	14	Yes
56	26355	5546	15	Yes
57	26830	5547	17	Yes
58	27305	5548	17	Yes
59	27780	5549	14	Yes
60	28255	5550	17	Yes
61	28730	5551	16	Yes
62	29205	5552	16	Yes
63	29680	5553	21	Yes
64	30155	5554	21	Yes
65	30630	5555	19	Yes
66	31105	5556	19	Yes
67	31580	5557	13	Yes
68	32055	5558	16	Yes
69	32530	5559	17	Yes
70	33005	5560	15	Yes
71	33480	5561	15	Yes
72	33955	5562	16	Yes
73	34430	5563	13	Yes

TYPE 6 DETECTION PROBABILITY (CONTINUED)

74	34905	5564	15	Yes
75	35380	5565	12	Yes
76	35855	5566	18	Yes
77	36330	5567	14	Yes
78	36805	5568	17	Yes
79	37280	5569	13	Yes

5. BRIDGE MODE RESULTS

Per KDB 905462, Section 5.1 (footnote 1):

Networks Access Points with Bridge and/or MESH modes of operation are permitted to operate in the DFS bands but must employ a DFS function. The functionality of the Bridge mode as specified in §15.403(a) must be validated in the DFS test report. Devices operating as relays must also employ DFS function. The method used to validate the functionality must be documented and validation data must be documented. Bridge mode can be validated by performing a test statistical performance check (Section 7.8.4) on any one of the radar types. This is an abbreviated test to verify DFS functionality. MESH mode operational methodology must be submitted in the application for certification for evaluation by the FCC.

This device does not support Bridge Mode therefore this test was not performed.