

Action	<p>This setting specifies the action to be taken by the router upon encountering traffic that matches the both of the following:</p> <ul style="list-style-type: none">• Source IP & port• Destination IP & port <p>With the value of Allow for the Action setting, the matching traffic passes through the router (to be routed to the destination). If the value of the Action setting is set to Deny, the matching traffic does not pass through the router (and is discarded).</p>
Event Logging	<p>This setting specifies whether or not to log matched firewall events. The logged messages are shown on the page Status>Event Log. A sample message is as follows:</p> <p>Aug 13 23:47:44 Denied CONN=Ethernet WAN SRC=20.3.2.1 DST=192.168.1.20 LEN=48 PROTO=TCP SPT=2260 DPT=80</p> <ul style="list-style-type: none">• CONN: The connection where the log entry refers to• SRC: Source IP address• DST: Destination IP address• LEN: Packet length• PROTO: Protocol• SPT: Source port• DPT: Destination port

Click **Save** to store your changes. To create an additional firewall rule, click **Add Rule** and repeat the above steps.

To change a rule's priority, simply drag and drop the rule:

- Hold the left mouse button on the rule.
- Move it to the desired position.
- Drop it by releasing the mouse button.



To remove a rule, click the  button.

Rules are matched from top to the bottom. If a connection matches any one of the upper rules, the matching process will stop. If none of the rules match the connection, the **Default** rule will be applied.

The **Default** rule is **Allow** for both outbound and inbound access.

Tip

If the default inbound rule is set to **Allow** for NAT-enabled WANs, no inbound Allow firewall rules will be required for inbound port forwarding and inbound NAT mapping rules. However, if the default inbound rule is set as **Deny**, a corresponding Allow firewall rule will be required.

Intrusion Detection and DoS Prevention

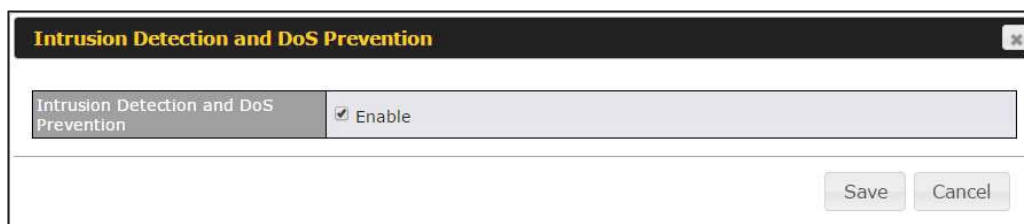

The Balance can detect and prevent intrusions and denial-of-service (DoS) attacks from the Internet. To turn on this feature, click , check the **Enable** check box for the **Intrusion Detection and DoS Prevention**, and press the **Save** button.

When this feature is enabled, the Balance will detect and prevent the following kinds of intrusions and denial-of-service attacks.

- Port scan
 - NMAP FIN/URG/PSH

- o Xmas tree
- o Another Xmas tree
- o Null scan
- o SYN/RST
- o SYN/FIN
- SYN flood prevention
- Ping flood attack prevention

10.12.2 Content Blocking

Application Blocking ?

Please Select Application... +

Web Blocking ?

Preset Category

<input type="radio"/> High	<input type="checkbox"/> Abortion	<input type="checkbox"/> Adware	<input type="checkbox"/> Aggressive
<input type="radio"/> Moderate	<input type="checkbox"/> Alcohol	<input type="checkbox"/> Anti-Spyware	<input type="checkbox"/> Chatroom
<input type="radio"/> Low	<input type="checkbox"/> Dating	<input type="checkbox"/> Drugs	<input type="checkbox"/> Ecommerce/Shopping
<input checked="" type="radio"/> Custom	<input type="checkbox"/> Entertainment	<input type="checkbox"/> File Hosting	<input type="checkbox"/> P2P/File sharing
	<input type="checkbox"/> Gambling	<input type="checkbox"/> Games	<input type="checkbox"/> Hacking
	<input type="checkbox"/> Instant Messaging	<input type="checkbox"/> Job Search/Employment	<input type="checkbox"/> Kids Time Wasting
	<input type="checkbox"/> Lingerie	<input type="checkbox"/> Malware	<input type="checkbox"/> Manga/Anime/Webcomic
	<input type="checkbox"/> Nudity	<input type="checkbox"/> News/Media	<input type="checkbox"/> Auctions
	<input type="checkbox"/> Phishing	<input type="checkbox"/> Pornography	<input type="checkbox"/> Proxy/Anonymizer
	<input type="checkbox"/> Radio	<input type="checkbox"/> Remote Access	<input type="checkbox"/> Ringtones
	<input type="checkbox"/> Search Engines	<input type="checkbox"/> Sexuality Education	<input type="checkbox"/> Social Networking
	<input type="checkbox"/> Sports	<input type="checkbox"/> Spyware	<input type="checkbox"/> Tobacco
	<input type="checkbox"/> Update Sites	<input type="checkbox"/> Vacation	<input type="checkbox"/> Violence
	<input type="checkbox"/> Viruses	<input type="checkbox"/> Weapons	<input type="checkbox"/> Weather
	<input type="checkbox"/> Webmail	<input type="checkbox"/> WebTV	

Customized Domains

cbs.com	✖
	+

Exempted Domains from Web Blocking

	+
--	---

Exempted User Groups ?

Manager	<input type="checkbox"/> Exempt
Staff	<input type="checkbox"/> Exempt
Guest	<input type="checkbox"/> Exempt

Exempted Subnets ?

Network		Subnet Mask	255.255.255.0 (/24) +

URL Logging

Enable	<input type="checkbox"/>
Log Server Host	<input style="width: 150px;" type="text"/> Port: <input style="width: 50px;" type="text"/>

Application Blocking

Choose applications to be blocked from LAN/PPTP/PepVPN peer clients' access, except for those on the Exempted User Groups or Exempted Subnets defined below.

Web Blocking

Defines web site domain names to be blocked from LAN/PPTP/PepVPN peer clients' access except for those on the Exempted User Groups or Exempted Subnets defined below.

If "foobar.com" is entered, any web site with a host name ending in foobar.com will be blocked, e.g. www.foobar.com, foobar.com, etc. However, "myfoobar.com" will not be blocked.

You may enter the wild card ".*" at the end of a domain name to block any web site with a host name having the domain name in the middle. If you enter "foobar.*", then "www.foobar.com", "www.foobar.co.jp", or "foobar.co.uk" will be blocked. Placing the wild card in any other position is not supported.

The device will inspect and look for blocked domain names on all HTTP traffic. Secure web (HTTPS) traffic is not supported.

Customized Domains

Enter an appropriate website address, and the Peplink Balance will block and disallow LAN/PPTP/SpeedFusion™ peer clients to access these websites. Exceptions can be added using the instructions in **Sections 21.2.1.4 and 21.2.1.5**.

You may enter the wild card ".*" at the end of a domain name to block any web site with a host name having the domain name in the middle. For example, If you enter "foobar.*," then "www.foobar.com," "www.foobar.co.jp," or "foobar.co.uk" will be blocked. Placing the wild card in any other position is not supported.

The Peplink Balance will inspect and look for blocked domain names on all HTTP traffic. Secure web (HTTPS) traffic is not supported.

Exempted User Groups

Check and select pre-defined user group(s) who can be exempted from the access blocking rules. User groups can be defined at **QoS>User Groups** section. Please refer to **Section 20.1** for details.

Exempted Subnets

With the subnet defined in the field, clients on the particular subnet(s) can be exempted from the

access blocking rules.

URL Logging

Click **enable**, and then enter the ip address and port (if applicable) where your remote syslog server is located.

10.13 OSPF & RIPv2

The Peplink Balance supports OSPF and RIPv2 dynamic routing protocols. Click the **Network** tab from the top bar, and then click the **OSPF & RIPv2** item on the sidebar to reach the following menu:

OSPF	
Router ID	LAN IP Address 
Area	Interfaces
0.0.0.0	PepVPN 
Add	
PepVPN OSPF Area	
0.0.0.0 	
RIPv2	
No RIPv2 Defined. 	

OSPF	
Router ID	This field determines the ID of the router. By default, this is specified as the LAN IP address. If you want to specify your own ID, enter it in the Custom field.
Area	This is an overview of the OSPFv2 areas you have defined. Click on the area name to configure it. To set a new area, click Add . To delete an existing area, click  .

OSPF settings
✕

Area ID	<input type="text" value="0.0.0.0"/>
Link Type	<input checked="" type="radio"/> Broadcast <input type="radio"/> Point-to-Point
Authentication	None ▼
Interfaces	<div style="display: flex; align-items: flex-start;"> <div style="width: 20px; text-align: center; font-size: 12px; color: #007bff; margin-right: 5px;">?</div> <ul style="list-style-type: none"> <input type="checkbox"/> Untagged LAN <input type="checkbox"/> V167 (192.168.167.1/24) <input type="checkbox"/> WAN 1 <input type="checkbox"/> WAN 2 <input type="checkbox"/> WAN 3 <input type="checkbox"/> WAN 4 <input type="checkbox"/> WAN 5 <input checked="" type="checkbox"/> PepVPN </div>

OSPF Settings	
Area ID	Determine the name of your Area ID to apply to this group. Machines linked to this group will send and receive related OSPF packets, while unlinked machines will ignore it.
Link Type	Choose the network type that this area will use.
Authentication	Choose an authentication method, if one is used, from this drop-down menu. Available options are MD5 and Text . Enter the authentication key next to the drop-down menu.
Interfaces	Determine which interfaces this area will use to listen to and deliver OSPF packets

To access RIPv2 settings, click .

RIPv2 settings ✕

Authentication	None ▾
Interfaces	<input type="checkbox"/> Untagged LAN <input type="checkbox"/> V167 (192.168.167.1/24) <input type="checkbox"/> WAN 1 <input type="checkbox"/> WAN 2 <input type="checkbox"/> WAN 3 <input type="checkbox"/> WAN 4 <input type="checkbox"/> WAN 5

RIPv2 Settings	
Authentication	Choose an authentication method, if one is used, from this drop-down menu. Available options are MD5 and Text . Enter the authentication key next to the drop-down menu.
Interfaces	Determine which interfaces this group will use to listen to and deliver RIPv2 packets.

OSPF & RIPv2 Route Advertisement

PepVPN Route Isolation ?	<input type="checkbox"/> Enable				
Network Advertising ?	--- ▾ + <small>All LAN/VLAN networks will be advertised when no network advertising is chosen.</small>				
Static Route Advertising ?	<input checked="" type="checkbox"/> Enable <table border="1" style="width: 100%; border-collapse: collapse;"> <thead> <tr> <th style="width: 50%;">Excluded Networks</th> <th style="width: 50%;">Subnet Mask</th> </tr> </thead> <tbody> <tr> <td><input type="text"/></td> <td>255.255.255.0 (/24) ▾ +</td> </tr> </tbody> </table>	Excluded Networks	Subnet Mask	<input type="text"/>	255.255.255.0 (/24) ▾ +
Excluded Networks	Subnet Mask				
<input type="text"/>	255.255.255.0 (/24) ▾ +				

OSPF & RIPv2 Route Advertisement	
PepVPN Route Isolation	Isolate PepVPN peers from each other. Received PepVPN routes will not be forwarded to other PepVPN peers to reduce bandwidth consumption..
Network Advertising	Networks to be advertised over OSPF & RIPv2. If no network is selected, all LAN / VLAN networks will be advertised by default.
Static Route Advertising	Enable this option to advertise LAN static routes over OSPF & RIPv2. Static routes that match the Excluded Networks table will not be advertised.

10.14 BGP

Click the Network tab from the top bar, and then click the **BGP** item on the sidebar to configure BGP.

BGP	AS	Neighbors	
Uplink	64520	172.16.51.1	
<input type="button" value="Add"/>			

Click "x" to delete a BGP profile

Click "Add" to add a new BGP profile

BGP Profile						
Profile Name	<input type="text"/>					
Enable	<input checked="" type="checkbox"/>					
Interface	WAN 1 ▾					
Router ID	<input checked="" type="radio"/> LAN IP Address <input type="radio"/> Custom: <input type="text"/>					
Autonomous System	<input type="text"/>					
Neighbor	IP Address	Autonomous System	Multihop / TTL	Password	AS-Path Prepending	<input type="text"/>
	<input type="text"/>	<input type="text"/>	disable	<input type="text"/>	<input type="text"/>	<input type="text"/>
Hold Time		240 <input type="text"/>				

BGP	
Name	This field is for specifying a name to represent this profile.
Enable	When this box is checked, this BGP profile will be enabled. Otherwise, it will be disabled.
Interface	The interface where BGP neighbor is located
Autonomous System	The Autonomous System Number (ASN) of this profile
Neighbor	BGP Neighbor's details
IP address	Neighbor's IP address
Autonomous	Neighbor's ASN

System	
Multihop/TTL	Time-to-live (TTL) of BGP packet. Leave it blank if BGP neighbor is directly connected, otherwise you must specify a TTL value. Accurately, this option should be used if the configured neighbor IP address does not match the selected Interface's network subnets. TTL value must be between 2 to 255.
Password	Optional password for MD5 authentication of BGP sessions.
AS-Path Prepending:	AS path to be prepended to the routes received from this neighbor. The value must be a comma separated ASN. For example "64530,64531" will prepend "64530, 64531" to received routes.
Hold Time	Time in seconds to wait for a keepalive message from the neighbor before considering the BGP connection is staled. This value must be either 0 (infinite hold time) or between 3 and 65535 inclusively.

Route Advertisement			
Network Advertising		---	
Static Route Advertising		<input checked="" type="checkbox"/> Enable	
		Excluded Networks	Subnet Mask
			255.255.255.0 (/24)
Advertise OSPF Route		<input type="checkbox"/>	

Network Advertising	Networks to be advertised to BGP neighbor.
Static Route Advertising	Enable this option to advertise LAN static routes. Static routes that match the Excluded Networks table will not be advertised.
Advertise OSPF Route	When this box is checked, all learnt OSPF routes will be advertised.

Route Import			
Filter Mode	<input style="float: left; margin-right: 5px;" type="button" value="?"/> Accept ▼		
Restricted Networks	Network	Subnet Mask	Exact Match
		255.255.255.0 (/24) ▼	<input type="checkbox"/>
			<input type="button" value="+"/>

Filter Mode	This option selects the route import filter mode. None: all BGP routes will be accepted. Accept: Routes in "Restricted Networks" will be accepted, routes not in the list will be rejected. Reject: Routes in "Restricted Networks" will be rejected, routes not in the list will be accepted.
Restricted Networks	This specifies the network in the "route import" entry Exact Match: When this box is checked, only routes with the same Networks and Subnet Mask will be filtered. Otherwise, routes within the Networks and Subnet will be filtered.

Route Export	
Export to other BGP Profile	<input style="float: left; margin-right: 5px;" type="button" value="?"/> <input type="checkbox"/>
Export to OSPF	<input style="float: left; margin-right: 5px;" type="button" value="?"/> <input type="checkbox"/>

Export to other BGP Profile	When this box is checked, routes learnt from this BGP profile will export to other BGP profiles.
Export to OSPF	When this box is checked, routes learnt from this BGP profile will export to the OSPF routing protocol.

10.15 Remote User Access

Networks routed by a Peplink Balance can be remotely accessed via L2TP with IPsec or PPTP. To configure this feature, navigate to **Network > Remote User Access**

Remote User Access Settings			
Enable	<input checked="" type="checkbox"/>		
VPN Type	<input checked="" type="radio"/> L2TP with IPsec <input type="radio"/> PPTP <small>IPsec NAT-Traversal will be enabled to ensure compatibility for most of the devices</small>		
Preshared Key	<input type="text" value="....."/> <input checked="" type="checkbox"/> Hide Characters		
Listen On	Connection / IP Address(es)		
	<input checked="" type="checkbox"/> WAN1	<input checked="" type="checkbox"/> 10.10.12.47 (Interface IP)	
	<input checked="" type="checkbox"/> WAN2	<input checked="" type="checkbox"/> Interface IP	
	<input checked="" type="checkbox"/> WAN3	<input checked="" type="checkbox"/> Interface IP	
	<input checked="" type="checkbox"/> Mobile Internet	<input checked="" type="checkbox"/> Interface IP	
User Accounts	Username	Password	
	admin	<input checked="" type="checkbox"/>
	<input type="text"/>	<input type="text"/>	<input type="checkbox"/>

Remote User Access Settings	
Enable	Click the checkbox to enable Remote User Access.
VPN Type	Determine whether remote devices can connect to the Balance using L2TP with IPsec or PPTP. For greater security, we recommend you connect using L2TP with IPsec.
Preshared Key	Enter your preshared key in the text field. Please note that remote devices will need this preshared key to access the Balance.
Listen On	This setting is for specifying the WAN IP addresses where the PPTP server of the router should listen on.
User Accounts	This setting allows you to define the PPTP User Accounts. Click Add to input username and password to create an account. After adding the user accounts, you can click on a username to edit the account password. Click the button X to delete the account in its corresponding row.

Click the  button to switch to enters user accounts by pasting the information in.CSV format.

10.16 Misc. Settings

10.16.1 High Availability

The Peplink Balance supports high availability (HA) configurations via an open standard virtual router redundancy protocol (VRRP, RFC 3768).

In an HA configuration, two same-model Peplink Balance units provide redundancy and failover in a master-slave arrangement. In the event that the master unit is down, the slave unit becomes active.

High availability will be disabled automatically where there is a drop-in connection configured on a LAN bypass port.

The following diagram illustrates an HA configuration with two Peplink Balance units and two Internet connections:

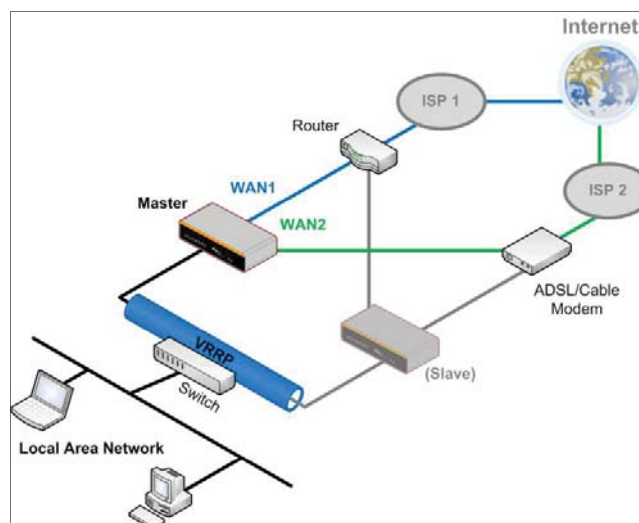

In the diagram, the WAN ports of each Peplink Balance unit connect to the router and to the modem. Both Peplink Balance units connect to the same LAN switch via a LAN port.

An elaboration on the technical details of the implementation of virtual router redundancy protocol (VRRP, RFC 3768) by the Balance follows:

- In an HA configuration, the two Peplink Balance units communicate with each other using VRRP over the LAN.
- The two Peplink Balance units broadcast heartbeat signals to the LAN at a frequency of one heartbeat signal per second.

- In the event that no heartbeat signal from the master Peplink Balance unit is received in 3 seconds (or longer) since the last heartbeat signal, the slave Peplink Balance unit becomes active.
- The slave Peplink Balance unit initiates the WAN connections and binds to a previously configured LAN IP address.
- At a subsequent point when the master Peplink Balance unit recovers, it will once again become active.

You can configure high availability at **Network>Misc. Settings>High Availability**.

Interface for Master Router

Interface for Slave Router

High Availability	
Enable	<input checked="" type="checkbox"/>
Group Number	5
Preferred Role	<input checked="" type="radio"/> Master <input type="radio"/> Slave
Resume Master Role Upon Recovery	<input checked="" type="checkbox"/>
Virtual IP	
LAN Administration IP	192.168.1.1
Subnet Mask	255.255.255.0

High Availability	
Enable	<input checked="" type="checkbox"/>
Group Number	5
Preferred Role	<input type="radio"/> Master <input checked="" type="radio"/> Slave
Configuration Sync.	<input checked="" type="checkbox"/> Master Serial Number: 5454-5454-5454
Virtual IP	
LAN Administration IP	192.168.1.1
Subnet Mask	255.255.255.0

High Availability	
Enable	Checking this box specifies that the Peplink Balance unit is part of a high availability configuration.
Group Number	This number identifies a pair of Peplink Balance units operating in a high availability configuration. The two Peplink Balance units in the pair must have the same Group Number value.
Preferred Role	This setting specifies whether the Peplink Balance unit operates in master or slave mode. Click the corresponding radio button to set the role of the unit. One of the units in the pair must be configured as the master, and the other unit must be configured as the slave.
Resume Master Role Upon Recovery	This option is displayed when Master mode is selected in Preferred Role . If this option is enabled, once the device has recovered from an outage, it will take over and resume its Master role from the slave unit.
Configuration Sync.	This option is displayed when Slave mode is selected in Preferred Role . If this option is enabled and the Master Serial Number entered matches with the actual master unit's, the master unit will automatically transfer the configuration to this unit. Please make sure the LAN IP Address and the Subnet Mask fields are set correctly in the LAN settings page. You can refer to the Event Log for the configuration synchronization status.
Master Serial Number	If Configuration Sync. is checked, the serial number of the master unit is required here for the feature to work properly.

Virtual IP	The HA pair must share the same Virtual IP . The Virtual IP and the LAN Administration IP must be under the same network.
LAN Administration IP	This setting specifies a LAN IP address to be used for accessing administration functionality. This address should be unique within the LAN.
Subnet Mask	This setting specifies the subnet mask of the LAN.

Important Note

For Balance routers in NAT mode, the virtual IP (VIP) should be set as the default gateway for all hosts sitting on the LAN segment. For example, a firewall sitting behind the Balance should set its default gateway as the virtual IP instead of the IP of the master Balance.

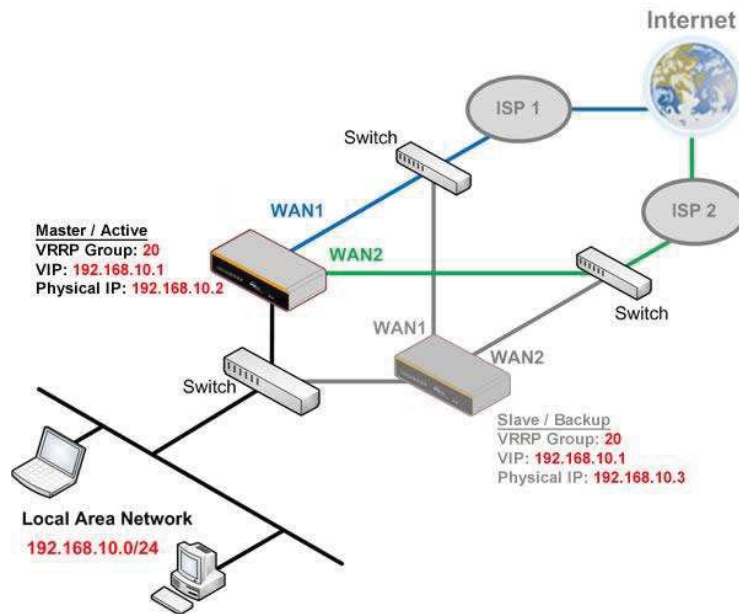

In drop-in mode, no other configuration needs to be set.

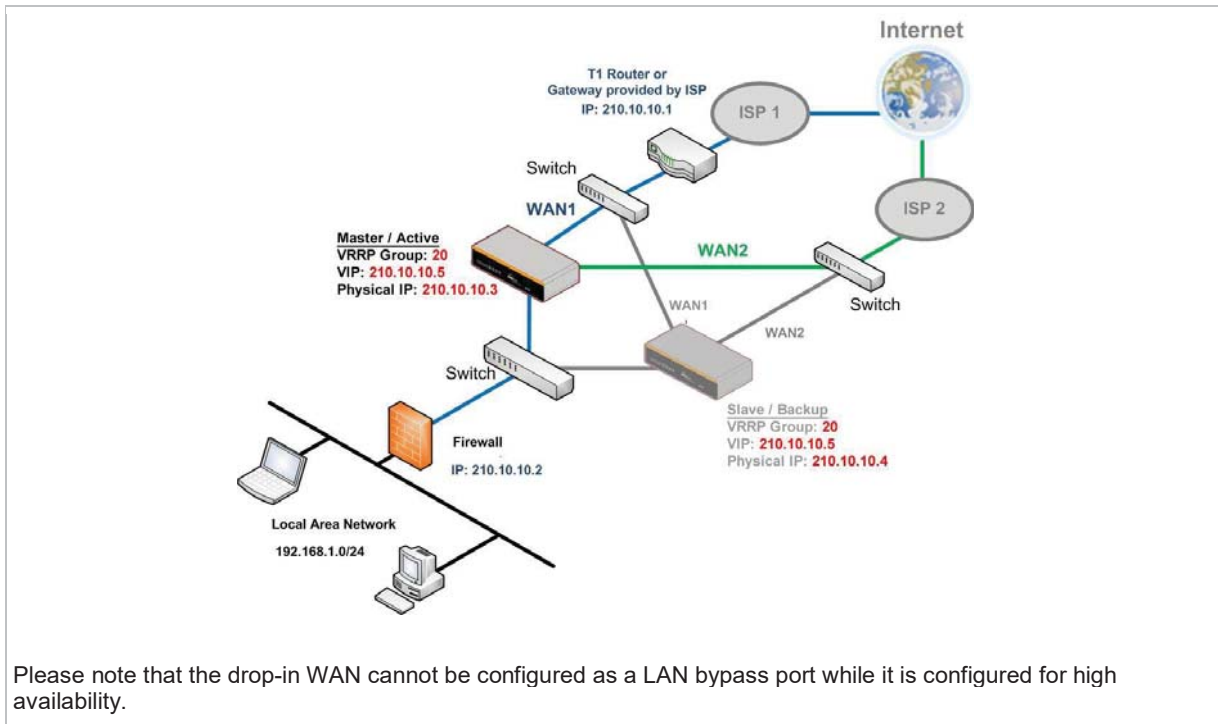

10.16.2 Certificate Manager

Certificate Manager			
VPN Certificate		No Certificate	Assign
Web Admin SSL Certificate		No Certificate	Assign
Captive Portal SSL Certificate		No Certificate	Assign

This section allows you to assign certificates for local VPN and web admin SSL. The local keys will not be transferred to another device by any means.

10.16.3 Service Forwarding

Service forwarding settings are located at **Network>Misc. Settings>Service Forwarding**.

SMTP Forwarding Setup	
SMTP Forwarding	<input type="checkbox"/> Enable
Web Proxy Forwarding Setup	
Web Proxy Forwarding	<input type="checkbox"/> Enable
DNS Forwarding Setup	
Forward Outgoing DNS Requests to Local DNS Proxy	<input type="checkbox"/> Enable
Custom Service Forwarding Setup	
Custom Service Forwarding	<input type="checkbox"/> Enable

Service Forwarding	
SMTP Forwarding	When this option is enabled, all outgoing SMTP connections destined for any host at TCP port 25 will be intercepted. These connections will be redirected to a specified SMTP server and port number. SMTP server settings for each WAN can be specified after selecting Enable .
Web Proxy Forwarding	When this option is enabled, all outgoing connections destined for the proxy server specified in Web Proxy Interception Settings will be intercepted. These connections will be redirected to a specified web proxy server and port number. Web proxy interception settings and proxy server settings for each WAN can be specified after selecting Enable .
DNS Forwarding	When this option is enabled, all outgoing DNS lookups will be intercepted and redirected to the built-in DNS name server. If any LAN device is using the DNS name servers of a WAN connection, you may want to enable this option to enhance the DNS availability without modifying the DNS server setting of the clients. The built-in DNS name server will distribute DNS lookups to corresponding DNS servers of all available WAN connections. In this case, DNS service will not be interrupted, even if any WAN connection is down.
Custom Service Forwarding	When custom service forwarding is enabled, outgoing traffic with the specified TCP port will be forwarded to a local or remote server by defining its IP address and port number.

SMTP Forwarding

Some ISPs require their users to send e-mails via the ISP's SMTP server. All outgoing SMTP connections are blocked except those connecting to the ISP's. The Peplink Balance supports the interception and redirection of all outgoing SMTP connections (destined for TCP port 25) via a WAN connection to the WAN's corresponding SMTP server.

SMTP Forwarding Setup			
SMTP Forwarding		<input checked="" type="checkbox"/> Enable	
Connection	Enable Forwarding?	SMTP Server	SMTP Port
WAN 1	<input type="checkbox"/>		
WAN 2	<input checked="" type="checkbox"/>	22.2.2.2	25
WAN 3	<input checked="" type="checkbox"/>	33.3.3.2	25
WAN 4	<input type="checkbox"/>		

To enable the feature, select **Enable** under **SMTP Forwarding Setup**. Check **Enable Forwarding** for the WAN connection(s) that needs forwarding. Under **SMTP Server**, enter the ISP's e-mail server host name or IP address. Under **SMTP Port**, enter the TCP port number for each WAN.

The Peplink Balance will intercept SMTP connections. Choose a WAN port according to the outbound policy, and then forward the connection to the SMTP server, if the chosen WAN has enabled forwarding. If the forwarding is disabled for a WAN connection, SMTP connections for the WAN will be simply be forwarded to the connection's original destination.

Note

If you want to route all SMTP connections only to particular WAN connection(s), you should create a custom rule in outbound policy (see [Section 16.1](#)).

Web Proxy Forwarding

Web Proxy Forwarding Setup			
Web Proxy Forwarding		<input checked="" type="checkbox"/> Enable	
Web Proxy Interception Settings			
Proxy Server		IP Address <input type="text" value="123.123.11.22"/>	Port <input type="text" value="8080"/>
<small>(Current settings in users' browser)</small>			
Connection	Enable Forwarding?	Proxy Server IP Address : Port	
WAN 1	<input type="checkbox"/>		:
WAN 2	<input checked="" type="checkbox"/>	22.2.2.2	: 8765
WAN 3	<input checked="" type="checkbox"/>	33.3.3.2	: 8080
WAN 4	<input type="checkbox"/>		:

When this feature is enabled, the Peplink Balance will intercept all outgoing connections destined for the proxy server specified in **Web Proxy Server Interception Settings**. Then it will choose a WAN connection according to the outbound policy and forward the connection to the specified web proxy server and port number. Redirected server settings for each WAN can be

set here. If forwarding is disabled for a WAN, then web proxy connections for that WAN will simply be forwarded to the connection’s original destination.

DNS Forwarding

DNS Forwarding Setup	
Forward Outgoing DNS Requests to Local DNS Proxy	<input checked="" type="checkbox"/> Enable

When DNS forwarding is enabled, all clients’ outgoing DNS requests will also be intercepted and forwarded to the built-in DNS proxy server.

Custom Service Forwarding

Custom Service Forwarding Setup			
Custom Service Forwarding	<input checked="" type="checkbox"/> Enable		
Settings	TCP Port	Server IP Address	Server Port
	<input type="text"/>	<input type="text"/>	<input type="text"/>
			+

After clicking the **enable** checkbox, enter your TCP port for traffic heading to the router, and then specify the IP Address and Port of the server you wish to forward to the service to.

10.16.4 Service Passthrough

Service passthrough settings can be found at **Network>Misc. Settings>Service Passthrough**.

Service Passthrough Support	
SIP	<input type="radio"/> Standard Mode <input type="radio"/> Compatibility Mode <input checked="" type="checkbox"/> Define custom signal ports 1. <input type="text"/> 2. <input type="text"/> 3. <input type="text"/>
H.323	<input checked="" type="checkbox"/> Enable
FTP	<input checked="" type="checkbox"/> Enable <input checked="" type="checkbox"/> Define custom control ports 1. <input type="text"/> 2. <input type="text"/> 3. <input type="text"/>
TFTP	<input checked="" type="checkbox"/> Enable
IPsec NAT-T	<input checked="" type="checkbox"/> Enable <input checked="" type="checkbox"/> Define custom ports 1. <input type="text"/> 2. <input type="text"/> 3. <input type="text"/> <input checked="" type="checkbox"/> Route IPsec Site-to-Site VPN via <input type="text" value="WAN 1"/>

(Registered trademarks are copyrighted by their respective owner)

Some Internet services need to be specially handled in a multi-WAN environment. The Peplink Balance can handle these services such that Internet applications do not notice it is behind a multi-WAN router. Settings for service passthrough support are available here.

Service Passthrough Support

SIP	<p>Session initiation protocol, aka SIP, is a voice-over-IP protocol. The Peplink Balance can act as a SIP application layer gateway (ALG) which binds connections for the same SIP session to the same WAN connection and translate IP address in the SIP packets correctly in NAT mode. Such passthrough support is always enabled and there are two modes for selection: Standard Mode and Compatibility Mode.</p> <p>If your SIP server's signal port number is non-standard, you can check the box Define custom signal ports and input the port numbers to the text boxes.</p>
H.323	<p>With this option enabled, protocols that provide audio-visual communication sessions will be defined on any packet network and passthrough the Balance.</p>
FTP	<p>FTP sessions consist of two TCP connections; one for control and one for data. In a multi-WAN situation, they must be routed to the same WAN connection. Otherwise, problems will arise in transferring files. By default, the Peplink Balance monitors TCP control connections on port 21 for any FTP connections and binds TCP connections of the same FTP session to the same WAN.</p> <p>If you have an FTP server listening on a port number other than 21, you can check Define custom control ports and enter the port numbers in the text boxes.</p>
TFTP	<p>The Peplink Balance monitors outgoing TFTP connections and routes any incoming TFTP data packets back to the client. Select Enable if you want to enable TFTP passthrough support.</p>
IPsec NAT-T	<p>This field is for enabling the support of IPsec NAT-T passthrough. UDP ports 500, 4500, and 10000 are monitored by default.</p> <p>You may add more custom data ports that your IPsec system uses by checking Define custom ports. If the VPN contains IPsec site-to-site VPN traffic, check Route IPsec Site-to-Site VPN and choose the WAN connection to route the traffic to.</p>

11 AP Tab

11.1 AP

11.1.1 AP Controller

Clicking on the **AP** tab will default to this menu, where you can view basic AP management options:

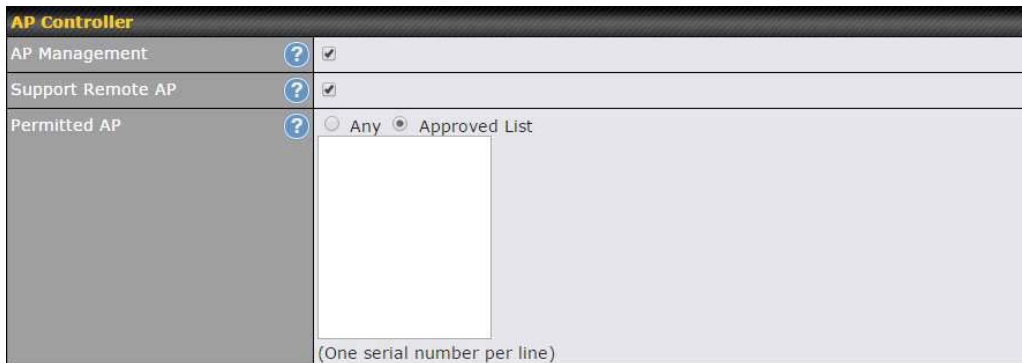

AP Controller	
AP Management	<p>The AP controller for managing Pepwave APs can be enabled by checking this box. When this option is enabled, the AP controller will wait for management connections originating from APs over the LAN on TCP and UDP port 11753. It will also wait for captive portal connections on TCP port 443. An extended DHCP option, CAPWAP Access Controller addresses (field 138), will be added to the DHCP server. A local DNS record, AP Controller, will be added to the local DNS proxy.</p>
Support Remote AP	<p>The AP controller supports remote management of Pepwave APs. When this option is enabled, the AP controller will wait for management connections originating from remote APs over the WAN on TCP and UDP port 11753. It will also wait for captive portal connections on TCP port 443.</p> <p>The DHCP server and/or local DNS server of the remote AP's network should be configured in the DNS Proxy Settings menu under Network>LAN. The procedure is as follows:</p> <ol style="list-style-type: none"> 1. Define an extended DHCP option, CAPWAP Access Controller addresses (field 138), in the DHCP server, where the values are the AP controller's public IP addresses; and/or 2. Create a local DNS record for the AP controller with a value corresponding to the AP controller's public IP address.
Permitted AP	<p>Access points to manage can be specified here. If Any is selected, the AP controller will manage any AP that reports to it. If Approved List is selected, only APs with serial numbers listed in the provided text box will be managed.</p>



11.1.2 Wireless SSID

Wireless network settings, including the name of the network (SSID) and security policy, can be

defined and managed in this section. After defining a wireless network, users can choose the network in **AP Profiles**.

SSID	Security Policy	
PEPLINK_E73D	WPA/WPA2 - Personal	
New SSID		

Click the button **New SSID** to create a new network profile, or click the existing network profile to modify its settings.

SSID Settings	
SSID	PEPLINK_DDCD
Enable	Always on ▼
VLAN ID	Untagged LAN ▼
Broadcast SSID	<input checked="" type="checkbox"/>
Data Rate	<input checked="" type="radio"/> Auto <input type="radio"/> Fixed
Multicast Filter	<input type="checkbox"/>
Multicast Rate	MCS0/6M ▼
IGMP Snooping	<input type="checkbox"/>
Layer 2 Isolation	<input type="checkbox"/>
Maximum number of clients	2.4 GHz: 0 5 GHz: 0 (0: Unlimited)
Band Steering	Disable ▼

SSID Settings	
SSID	This setting specifies the SSID of the virtual AP to be scanned by Wi-Fi clients.
Enable	Choose an operating schedule for this SSID. Define schedules under System > Schedule
VLAN ID	This setting specifies the VLAN ID to be tagged on all outgoing packets generated from this wireless network (i.e., packets that travel from the Wi-Fi segment through the Pepwave AP One unit to the Ethernet segment via the LAN port). The default value of this setting is 0 , which means VLAN tagging is disabled (instead of tagged with zero).
Broadcast SSID	This setting specifies whether or not Wi-Fi clients can scan the SSID of this wireless network. Broadcast SSID is enabled by default.
Data Rate ^A	Select Auto to allow the Peplink Balance to set the data rate automatically, or select Fixed and choose a rate from the displayed drop-down menu.
Multicast Filter^A	This setting enables the filtering of multicast network traffic to the wireless SSID.
Multicast Rate^A	This setting specifies the transmit rate to be used for sending multicast network traffic. The selected Protocol and Channel Bonding settings will affect the rate options and values available here.

IGMP Snooping ^A	To allow the Peplink Balance to listen to internet group management protocol (IGMP) network traffic, select this option.
DHCP Option 82 ^A	If you use a distributed DHCP server/relay environment, you can enable this option to provide additional information on the manner in which clients are physically connected to the network.
Network Priority (QoS) ^A	Select from Gold , Silver , and Bronze to control the QoS priority of this wireless network's traffic.
Layer 2 Isolation ^A	Layer 2 refers to the second layer in the ISO Open System Interconnect model. When this option is enabled, clients on the same VLAN, SSID, or subnet are isolated to that VLAN, SSID, or subnet, which can enhance security. Traffic is passed to upper communication layer(s). By default, the setting is disabled.
Maximum Number of Clients	Enter the maximum number of clients on the 2.4Ghz channel and on the 5Ghz channel.
Band Steering ^A	Band steering allows the Peplink Balance to steer AP clients from the 2.4 GHz band to the 5GHz band for better usage of bandwidth. To make steering mandatory, select Enforce . To cause the Peplink Balance to preferentially choose steering, select Prefer . The default for this setting is Disable .

^A - Advanced feature. Click the button on the top right-hand corner to activate.

Security Settings	
Security Policy	WPA2 - Personal ▼
Encryption	AES:CCMP
Shared Key	<input type="text"/>
	<input checked="" type="checkbox"/> Hide Characters

Security Settings	
Security Policy	This setting configures the wireless authentication and encryption methods. Available options are Open (No Encryption) , WPA/WPA2 - Personal , WPA/WPA2 – Enterprise and Static WEP .

Access Control	
Restricted Mode	None ▼

Access Control	
Restricted	The settings allow administrator to control access using Mac address filtering. Available options are None , Deny all except listed , Accept all except listed , and RADIUS MAC

Mode	<p>Authentication.</p> <p>When WPA/WPA2 - Enterprise is configured, RADIUS-based 802.1 x authentication is enabled. Under this configuration, the Shared Key option should be disabled. When using this method, select the appropriate version using the V1/V2 controls. The security level of this method is known to be very high.</p> <p>When WPA/WPA2- Personal is configured, a shared key is used for data encryption and authentication. When using this configuration, the Shared Key option should be enabled. Key length must be between eight and 63 characters (inclusive). The security level of this method is known to be high.</p> <p>The configuration of Static WEP parameters enables pre-shared WEP key encryption. Authentication is not supported by this method. The security level of this method is known to be weak.</p>
MAC Address List	<p>Connection coming from the MAC addresses in this list will be either denied or accepted based the option selected in the previous field.</p>

RADIUS Server Settings	Primary Server	Secondary Server
Host	<input type="text"/>	<input type="text"/>
Secret	<input type="text"/>	<input type="text"/>
Authentication Port	1812 <input type="button" value="Default"/>	1812 <input type="button" value="Default"/>
Accounting Port	1813 <input type="button" value="Default"/>	1813 <input type="button" value="Default"/>

RADIUS Server Settings	
Host	Enter the IP address of the primary RADIUS server and, if applicable, the secondary RADIUS server.
Secret	Enter the RADIUS shared secret for the primary server and, if applicable, the secondary RADIUS server.
Authentication Port	In field, enter the UDP authentication port(s) used by your RADIUS server(s) or click the Default button to enter 1812 .
Accounting Port	In field, enter the UDP accounting port(s) used by your RADIUS server(s) or click the Default button to enter 1813 .

Guest Protect			
Block All Private IP	<input type="checkbox"/>		
Custom Subnet	Network	Subnet Mask	
	<input type="text"/>	255.255.255.0 (/24) ▾	<input type="button" value="+"/>
Block Exception	Network	Subnet Mask	
	<input type="text"/>	255.255.255.0 (/24) ▾	<input type="button" value="+"/>
Block PepVPN	<input type="checkbox"/>		

Guest Protect	
Block All Private IP	Check this box to deny all connection attempts by private IP addresses.
Custom Subnet	To create a custom subnet for guest access, enter the IP address and choose a subnet mask from the drop-down menu. To add the new subnet, click <input type="button" value="+"/> . To delete a custom subnet, click <input type="button" value="x"/> .
Block Exception	To block access from a particular subnet, enter the IP address and choose a subnet mask from the drop-down menu. To add the new subnet, click <input type="button" value="+"/> . To delete a blocked subnet, click <input type="button" value="x"/> .
Block PepVPN	To block PepVPN access, check this box.

Bandwidth Management	
Upstream Limit	<input type="text" value="0"/> kbps (0: Unlimited)
Downstream Limit	<input type="text" value="0"/> kbps (0: Unlimited)
Client Upstream Limit	<input type="text" value="0"/> kbps (0: Unlimited)
Client Downstream Limit	<input type="text" value="0"/> kbps (0: Unlimited)
Max Number of Clients	<input type="text" value="0"/> (0: Unlimited)

Bandwidth Management	
Upstream Limit	Enter a value in kpbs to limit the wireless network's upstream bandwidth. Enter 0 to allow unlimited upstream bandwidth.
Downstream Limit	Enter a value in kpbs to limit the wireless network's downstream bandwidth. Enter 0 to allow unlimited downstream bandwidth.

Client Upstream Limit	Enter a value in kpbs to limit connected clients' upstream bandwidth. Enter 0 to allow unlimited upstream bandwidth.
Client Downstream Limit	Enter a value in kpbs to limit connected clients' downstream bandwidth. Enter 0 to allow unlimited downstream bandwidth.
Max Number of Clients	Enter the maximum number of clients that can simultaneously connect to the wireless network or enter 0 to allow an unlimited number of connections.

Firewall Settings	
Firewall Mode	Choose Flexible – Allow all except... or Lockdown – Block all except... to turn on the firewall. Once you save changes, the New Rule button will appear for you to create rules for the firewall exceptions. See the discussion below for details on creating a firewall rule. To delete a rule, click the associated X button. To turn off the firewall, select Disable .

Firewall Rule	
Name	Enter a descriptive name for the firewall rule in this field.
Type	Choose Port , Domain , IP Address , or MAC Address to allow or deny traffic from any of those identifiers. Depending on the option chosen, the following fields will vary.
Protocol /	Choose TCP or UDP from the Protocol drop-down menu to allow or deny traffic using either of those protocols. From the Port drop-down menu, choose Any Port to allow or deny TCP or

Port	UDP traffic on any port. Choose Single Port and then enter a port number in the provided field to allow or block TCP or UDP traffic from that port only. You can also choose Port Range and enter a range of ports in the provided fields to allow or deny TCP or UDP traffic from the specified port range.
IP Address / Subnet Mask	If you have chosen IP Address as your firewall rule type, enter the IP address and subnet mask identifying the subnet to allow or deny.
MAC Address	If you have chosen MAC Address as your firewall rule type, enter the MAC address identifying the machine to allow or deny.

11.1.3 Settings

AP Settings	
SSID	<input checked="" type="checkbox"/> 2.4 GHz <input checked="" type="checkbox"/> 5 GHz <input type="checkbox"/> Integrated AP supports 2.4 GHz only. Testing
Operating Country	United States
Preferred Frequency	<input checked="" type="radio"/> 2.4 GHz <input type="radio"/> 5 GHz Integrated AP supports 2.4 GHz only.

AP Settings	
SSID	You can select the wireless networks for 2.4 GHz or 5 GHz separately for each SSID.
Operating Country	This drop-down menu specifies the national/regional regulations which the Wi-Fi radio should follow. <ul style="list-style-type: none"> If a North American region is selected, RF channels 1 to 11 will be available and the maximum transmission power will be 26 dBm (400 mW). If European region is selected, RF channels 1 to 13 will be available. The maximum transmission power will be 20 dBm (100 mW). NOTE: Users are required to choose an option suitable to local laws and regulations.
Preferred Frequency	Indicate the preferred frequency to use for clients to connect.

Important Note

Per FCC regulation, the country selection is not available on all models marketed in the US. All US models are fixed to US channels only.

	2.4 GHz	5 GHz
Protocol	802.11ng	802.11n/ac
Channel Width	20 MHz	Auto
Channel	Auto <input type="button" value="Edit"/> Channels: 1 2 3 4 5 6 7 8 9 10 11	Auto <input type="button" value="Edit"/> Channels: 36 40 44 48 52 56 60 64 100 104 108 112 116 120 124 128 132 136 140 149 153 157 161 165
Auto Channel Update	Daily at 03:00 <input checked="" type="checkbox"/> Wait until no active client associated	Daily at 03:00 <input checked="" type="checkbox"/> Wait until no active client associated
Output Power	Fixed: Max <input type="checkbox"/> Boost	Fixed: Max <input type="checkbox"/> Boost
Client Signal Strength Threshold	0 -95 dBm (0: Unlimited)	0 -95 dBm (0: Unlimited)
Maximum number of clients	0 (0: Unlimited)	0 (0: Unlimited)

AP Settings (part 2)

Protocol	This option allows you to specify whether 802.11b and/or 802.11g client association requests will be accepted. Available options are 802.11ng and 802.11na . By default, 802.11ng is selected.
Channel Width	Available options are 20 MHz , 40 MHz , and Auto (20/40 MHz) . Default is Auto (20/40 MHz) , which allows both widths to be used simultaneously.
Channel	This option allows you to select which 802.11 RF channel will be utilized. Channel 1 (2.412 GHz) is selected by default.
Auto Channel Update	Indicate the time of day at which update automatic channel selection.
Output Power	This option is for specifying the transmission output power for the Wi-Fi AP. There are 4 relative power levels available – Max , High , Mid , and Low . The actual output power will be bound by the regulatory limits of the selected country.
Client Signal Strength Threshold	This setting determines the maximum strength at which the Wi-Fi AP can broadcast
Maximum number of clients	This setting determines the maximum number of clients that can connect to this Wi-Fi frequency.

Advanced Wi-Fi AP settings can be displayed by clicking the  on the top right-hand corner of the **Wi-Fi AP Settings** section, which can be found at **AP>Settings**. Other models will display a separate section called **Wi-Fi AP Advanced Settings**, which can be found at **Advanced>Wi-Fi Settings**.

Management VLAN ID	<input type="text" value="Untagged LAN (No VLAN)"/>
Operating Schedule	Always on
Beacon Rate	1 Mbps <small>6 Mbps will be used for 5 GHz radio</small>
Beacon Interval	100 ms
DTIM	1 <input type="button" value="Default"/>
RTS Threshold	0 <input type="button" value="Default"/>
Fragmentation Threshold	0 (0: Disable) <input type="button" value="Default"/>
Distance / Time Converter	<input type="text" value="4050"/> m <small>Note: Input distance for recommended values</small>
Slot Time	<input type="radio"/> Auto <input checked="" type="radio"/> Custom <input type="text" value="9"/> μ s <input type="button" value="Default"/>
ACK Timeout	48 μ s <input type="button" value="Default"/>
Frame Aggregation	<input type="checkbox"/>

Advanced AP Settings	
Management VLAN ID	<p>This field specifies the VLAN ID to tag to management traffic, such as communication traffic between the AP and the AP Controller. The value is zero by default, which means that no VLAN tagging will be applied.</p> <p>NOTE: Change this value with caution as alterations may result in loss of connection to the AP Controller.</p>
Operating Schedule	<p>Choose from the schedules that you have defined in System>Schedule. Select the schedule for the integrated AP to follow from the drop-down menu.</p>
Beacon Rate ^A	<p>This option is for setting the transmit bit rate for sending a beacon. By default, 1Mbps is selected.</p>
Beacon Interval ^A	<p>This option is for setting the time interval between each beacon. By default, 100ms is selected.</p>
DTIM ^A	<p>This field allows you to set the frequency for the beacon to include delivery traffic indication messages. The interval is measured in milliseconds. The default value is set to 1 ms.</p>
RTS Threshold ^A	<p>The RTS (Request to Clear) threshold determines the level of connection required before the AP starts sending data. The recommended standard of the RTS threshold is around 500.</p>
Fragmentation Threshold ^A	<p>This setting determines the maximum size of a packet before it gets fragmented into multiple pieces.</p>
Distance / Time Convertor	<p>Select the range you wish to cover with your Wi-Fi, and the router will make recommendations for the Slot Time and ACK Timeout.</p>

Slot Time ^A	This field is for specifying the unit wait time before transmitting a packet. By default, this field is set to 9 μs .
ACK Timeout ^A	This field is for setting the wait time to receive an acknowledgement packet before performing a retransmission. By default, this field is set to 48 μs .
Frame Aggregation ^A	This option allows you to enable frame aggregation to increase transmission throughput.

^A - Advanced feature, please click the  button on the top right-hand corner to activate.

Web Administration Settings (on External AP)	
Enable	<input checked="" type="checkbox"/>
Web Access Protocol	<input type="radio"/> HTTP <input checked="" type="radio"/> HTTPS
Management Port	<input type="text" value="443"/>
HTTP to HTTPS Redirection	<input checked="" type="checkbox"/>
Admin Username	<input type="text" value="admin"/>
Admin Password	<input type="text" value="601202b1afc6"/> <input type="button" value="Generate"/>

Web Administration Settings	
Enable	Ticking this box enables web admin access for APs located on the WAN.
Web Access Protocol	Determines whether the web admin portal can be accessed through HTTP or HTTPS
Management Port	Determines the port at which the management UI can be accessed.
Admin Username	Determines the username to be used for logging into the web admin portal
Admin Password	Determines the password for the web admin portal on external AP.

11.2 AP Controller Status

11.2.1 Info

A comprehensive overview of your AP can be accessed by navigating to **AP > Info**.



AP Controller	
License Limit	This field displays the maximum number of AP your Balance router can control. You can purchase licenses to increase the number of AP you can manage.
Frequency	Underneath, there are two check boxes labeled 2.4 Ghz and 5 Ghz . Clicking either box will toggle the display of information for that frequency. By default, the graphs display the number of clients and data usage for both 2.4GHz and 5 GHz frequencies.
SSID	The colored boxes indicate the SSID to display information for. Clicking any colored box will toggle the display of information for that SSID. By default, all the graphs show information for all SSIDs.
No. of APs	This pie chart and table indicates how many APs are online and how many are offline.
No. of Clients	This graph displays the number of clients connected to each network at any given time. Mouse over any line on the graph to see how many clients connected to a specific SSID for that point in time.
Data Usage	This graph enables you to see the data usage of any SSID for any given time period. Mouse over any line on the graph to see the data usage by each SSID for that point in time. Use the buttons next to Zoom to select the time scale you wish to view. In addition, you could use the sliders at the bottom to further refine your timescale.

11.2.2 Access Points (Usage)

A detailed breakdown of data usage for each AP is available at **AP> Access Point**.

Search Filter

AP Name / Serial Number / SSID	<input type="text" value="All"/>
	<input type="checkbox"/> Include Offline APs
Search Result	

Managed APs Expand Collapse

Name	IP Address	MAC	Location	Firmware Pack ID	Configuration
▼ Default (8/9 online)					
[+] 1130-AG817-10000	10.8.82.11	00:1A:DD:BD:73:E0	-	3.5.2 None	<input checked="" type="checkbox"/> - 🔍 📄 📊

Usage

AP Name/Serial Number	This field enables you to quickly find your device if you know its name or serial number. Fill in the field to begin searching. Partial names and serial numbers are supported.																																																																																				
Online Status	This button toggles whether your search will include offline devices.																																																																																				
Managed Wireless Devices	<p>This table shows the detailed information on each AP, including channel, number of clients, upload traffic, and download traffic. Click the blue arrows at the left of the table to expand and collapse information on each device group. You could also expand and collapse all groups by using the Expand Collapse buttons.</p> <p>On the right of the table, you will see the following icons: 🔍 📄 📊.</p> <p>Click the 🔍 icon to see a usage table for each client:</p> <div style="border: 1px solid #ccc; padding: 5px; margin-top: 5px;"> <div style="background-color: #333; color: white; padding: 2px;">Client List ✖</div> <table border="1" style="width: 100%; border-collapse: collapse; font-size: 0.8em;"> <thead> <tr> <th>MAC Address</th> <th>IP Address</th> <th>Type</th> <th>Signal</th> <th>SSID</th> <th>Upload</th> <th>Download</th> </tr> </thead> <tbody> <tr><td>80:56:f2:98:75:ff</td><td>10.9.2.7</td><td>802.11ng</td><td>Excellent (37)</td><td>Balance</td><td>66.26 MB</td><td>36.26 MB</td></tr> <tr><td>c4:6a:b7:bf:d7:15</td><td>10.9.2.123</td><td>802.11ng</td><td>Excellent (42)</td><td>Balance</td><td>6.65 MB</td><td>2.26 MB</td></tr> <tr><td>70:56:81:1d:87:f3</td><td>10.9.2.102</td><td>802.11ng</td><td>Good (23)</td><td>Balance</td><td>1.86 MB</td><td>606.63 KB</td></tr> <tr><td>e0:63:e5:83:45:c8</td><td>10.9.2.101</td><td>802.11ng</td><td>Excellent (39)</td><td>Balance</td><td>3.42 MB</td><td>474.52 KB</td></tr> <tr><td>18:00:2d:3d:4e:7f</td><td>10.9.2.66</td><td>802.11ng</td><td>Excellent (25)</td><td>Balance</td><td>640.29 KB</td><td>443.57 KB</td></tr> <tr><td>14:5a:05:80:4f:40</td><td>10.9.2.76</td><td>802.11ng</td><td>Excellent (29)</td><td>Balance</td><td>2.24 KB</td><td>3.67 KB</td></tr> <tr><td>00:1a:dd:c5:4e:24</td><td>10.8.9.84</td><td>802.11ng</td><td>Excellent (29)</td><td>Wireless</td><td>9.86 MB</td><td>9.76 MB</td></tr> <tr><td>00:1a:dd:bb:29:ec</td><td>10.8.9.73</td><td>802.11ng</td><td>Excellent (25)</td><td>Wireless</td><td>9.36 MB</td><td>11.14 MB</td></tr> <tr><td>40:b0:fa:c3:26:2c</td><td>10.8.9.18</td><td>802.11ng</td><td>Good (23)</td><td>Wireless</td><td>118.05 MB</td><td>7.92 MB</td></tr> <tr><td>e4:25:e7:8a:d3:12</td><td>10.10.11.23</td><td>802.11ng</td><td>Excellent (35)</td><td>Marketing</td><td>74.78 MB</td><td>4.58 MB</td></tr> <tr><td>04:f7:e4:ef:68:05</td><td>10.10.11.71</td><td>802.11ng</td><td>Poor (12)</td><td>Marketing</td><td>84.84 KB</td><td>119.32 KB</td></tr> </tbody> </table> <div style="text-align: right; margin-top: 5px;">Close</div> </div>	MAC Address	IP Address	Type	Signal	SSID	Upload	Download	80:56:f2:98:75:ff	10.9.2.7	802.11ng	Excellent (37)	Balance	66.26 MB	36.26 MB	c4:6a:b7:bf:d7:15	10.9.2.123	802.11ng	Excellent (42)	Balance	6.65 MB	2.26 MB	70:56:81:1d:87:f3	10.9.2.102	802.11ng	Good (23)	Balance	1.86 MB	606.63 KB	e0:63:e5:83:45:c8	10.9.2.101	802.11ng	Excellent (39)	Balance	3.42 MB	474.52 KB	18:00:2d:3d:4e:7f	10.9.2.66	802.11ng	Excellent (25)	Balance	640.29 KB	443.57 KB	14:5a:05:80:4f:40	10.9.2.76	802.11ng	Excellent (29)	Balance	2.24 KB	3.67 KB	00:1a:dd:c5:4e:24	10.8.9.84	802.11ng	Excellent (29)	Wireless	9.86 MB	9.76 MB	00:1a:dd:bb:29:ec	10.8.9.73	802.11ng	Excellent (25)	Wireless	9.36 MB	11.14 MB	40:b0:fa:c3:26:2c	10.8.9.18	802.11ng	Good (23)	Wireless	118.05 MB	7.92 MB	e4:25:e7:8a:d3:12	10.10.11.23	802.11ng	Excellent (35)	Marketing	74.78 MB	4.58 MB	04:f7:e4:ef:68:05	10.10.11.71	802.11ng	Poor (12)	Marketing	84.84 KB	119.32 KB
MAC Address	IP Address	Type	Signal	SSID	Upload	Download																																																																															
80:56:f2:98:75:ff	10.9.2.7	802.11ng	Excellent (37)	Balance	66.26 MB	36.26 MB																																																																															
c4:6a:b7:bf:d7:15	10.9.2.123	802.11ng	Excellent (42)	Balance	6.65 MB	2.26 MB																																																																															
70:56:81:1d:87:f3	10.9.2.102	802.11ng	Good (23)	Balance	1.86 MB	606.63 KB																																																																															
e0:63:e5:83:45:c8	10.9.2.101	802.11ng	Excellent (39)	Balance	3.42 MB	474.52 KB																																																																															
18:00:2d:3d:4e:7f	10.9.2.66	802.11ng	Excellent (25)	Balance	640.29 KB	443.57 KB																																																																															
14:5a:05:80:4f:40	10.9.2.76	802.11ng	Excellent (29)	Balance	2.24 KB	3.67 KB																																																																															
00:1a:dd:c5:4e:24	10.8.9.84	802.11ng	Excellent (29)	Wireless	9.86 MB	9.76 MB																																																																															
00:1a:dd:bb:29:ec	10.8.9.73	802.11ng	Excellent (25)	Wireless	9.36 MB	11.14 MB																																																																															
40:b0:fa:c3:26:2c	10.8.9.18	802.11ng	Good (23)	Wireless	118.05 MB	7.92 MB																																																																															
e4:25:e7:8a:d3:12	10.10.11.23	802.11ng	Excellent (35)	Marketing	74.78 MB	4.58 MB																																																																															
04:f7:e4:ef:68:05	10.10.11.71	802.11ng	Poor (12)	Marketing	84.84 KB	119.32 KB																																																																															

Click the  icon to configure each client

AP Details ✕

Serial Number	1111-2222-3333
MAC Address	00:1A:DD:BD:73:E0
Product Name	Pepwave AP Pro Duo
Name	<input type="text"/>
Location	<input type="text"/>
Firmware Version	3.5.2
Firmware Pack	Default (None) ▾
AP Client Limit	<input checked="" type="radio"/> Follow AP Profile <input type="radio"/> Custom
2.4 GHz SSID List	T4Open
5 GHz SSID List	T4Open
Last config applied by controller	Mon Nov 23 11:25:03 HKT 2015
Uptime	Wed Nov 11 15:00:27 HKT 2015
Current Channel	1 (2.4 GHz) 153 (5 GHz)
Channel	2.4 GHz: Follow AP Profile ▾ 5 GHz: Follow AP Profile ▾
Output Power	2.4 GHz: Follow AP Profile ▾ 5 GHz: Follow AP Profile ▾

For easier network management, you can give each client a name and designate its location. You can also designate which firmware pack (if any) this client will follow, as well as the channels on which the client will broadcast.

Click the  icon to see a graph displaying usage:



Click any point in the graphs to display detailed usage and client information for that device, using that SSID, at that point in time. On the **Data Usage by** menu, you can

display the information by SSID or by AP send/receive rate.

Click the **Event** tab next to **Wireless Usage** to view a detailed event log for that particular device:

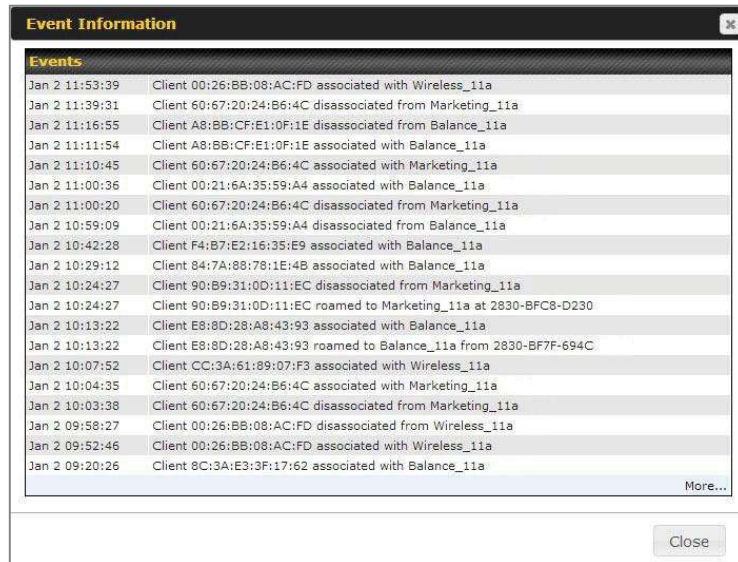

The screenshot shows a window titled "Event Information" with a close button in the top right corner. Below the title bar is a section labeled "Events" containing a list of events. Each event entry includes a timestamp, a client MAC address, and a description of the event. The events are listed in chronological order from top to bottom. At the bottom right of the list is a "More..." link, and at the bottom center of the window is a "Close" button.

Timestamp	Event Description
Jan 2 11:53:39	Client 00:26:BB:08:AC:FD associated with Wireless_11a
Jan 2 11:39:31	Client 60:67:20:24:B6:4C disassociated from Marketing_11a
Jan 2 11:16:55	Client A8:BB:CF:E1:0F:1E disassociated from Balance_11a
Jan 2 11:11:54	Client A8:BB:CF:E1:0F:1E associated with Balance_11a
Jan 2 11:10:45	Client 60:67:20:24:B6:4C associated with Marketing_11a
Jan 2 11:00:36	Client 00:21:6A:35:59:A4 associated with Balance_11a
Jan 2 11:00:20	Client 60:67:20:24:B6:4C disassociated from Marketing_11a
Jan 2 10:59:09	Client 00:21:6A:35:59:A4 disassociated from Balance_11a
Jan 2 10:42:28	Client F4:B7:E2:16:35:E9 associated with Balance_11a
Jan 2 10:29:12	Client 84:7A:88:78:1E:4B associated with Balance_11a
Jan 2 10:24:27	Client 90:B9:31:0D:11:EC disassociated from Marketing_11a
Jan 2 10:24:27	Client 90:B9:31:0D:11:EC roamed to Marketing_11a at 2830-BFC8-D230
Jan 2 10:13:22	Client E8:8D:28:A8:43:93 associated with Balance_11a
Jan 2 10:13:22	Client E8:8D:28:A8:43:93 roamed to Balance_11a from 2830-BF7F-694C
Jan 2 10:07:52	Client CC:3A:61:89:07:F3 associated with Wireless_11a
Jan 2 10:04:35	Client 60:67:20:24:B6:4C associated with Marketing_11a
Jan 2 10:03:38	Client 60:67:20:24:B6:4C disassociated from Marketing_11a
Jan 2 09:58:27	Client 00:26:BB:08:AC:FD disassociated from Wireless_11a
Jan 2 09:52:46	Client 00:26:BB:08:AC:FD associated with Wireless_11a
Jan 2 09:20:26	Client 8C:3A:E3:3F:17:62 associated with Balance_11a

11.2.3 Wireless SSID

In-depth SSID reports are available under AP > SSID.

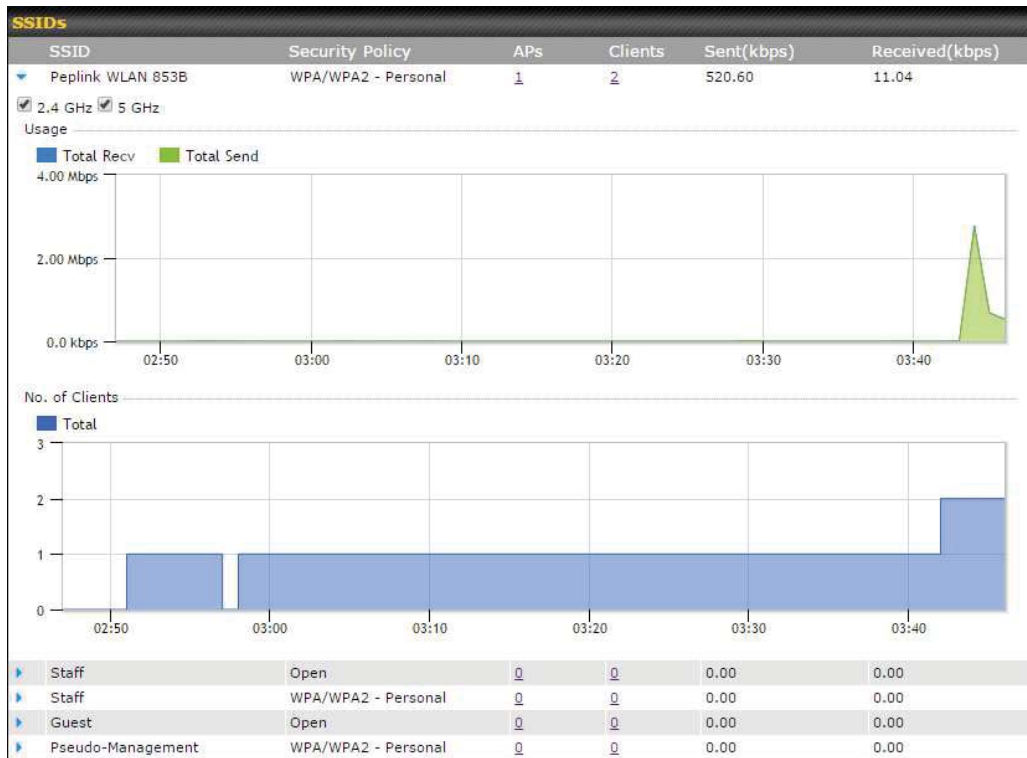

Click the blue arrow on any SSID to obtain more detailed usage information on each SSID.

11.2.4 Wireless Client

You can search for specific Wi-Fi users by navigating to **AP > Wireless Client**.

Search Filter

Client MAC / SSID / AP Serial Number	<input type="text"/>
Maximum Result (1-256)	<input type="text" value="50"/>
Search Result	

Top 10 Clients of last hour (Updated at 03:00)

Client MAC Address	Upload	Download	
C0:EE:FB:20:13:36	53.5 KB	101.4 KB	☆ 📊

Here, you will be able to see your network’s heaviest users as well as search for specific users. Click the ☆ icon to bookmark specific users, and click the 📊 icon for additional

details about each user:

Client C0:EE:FB:20:13:36 ✕

Information	
Status	Associated
Access Point	1111-2222-3333
SSID	Peplink WLAN 853B
IP Address	192.168.1.34
Duration	00:27:31
Usage (Upload / Download)	141.28 MB / 4.35 MB
RSSI	-48
Rate (Upload / Download)	150M / 48M
Type	802.11na

■ Download ■ Upload

SSID	AP	From	To	Upload	Download
Peplink WLAN 853B	192C-1835-642F	Nov 23 03:43:04	-	141.28 MB	4.35 MB
Peplink WLAN 853B	192C-1835-642F	Nov 23 02:58:36	Nov 23 03:47:52	173.7 KB	94.2 KB
Peplink WLAN 853B	192C-1835-642F	Nov 23 02:52:15	Nov 23 02:58:15	105.9 KB	62.5 KB

11.2.5 Nearby Device

A listing of near devices can be accessed by navigating to **AP > Controller Status > Nearby Device**.

Suspected Rogue APs					
BSSID	SSID	Channel	Encryption	Last Seen	Mark as
00:1A:DD:EC:25:22	Wireless	11	WPA2	10 hours ago	
00:1A:DD:EC:25:23	Accounting	11	WPA2	10 hours ago	
00:1A:DD:EC:25:24	Marketing	11	WPA2	11 hours ago	
00:03:7F:00:00:00	MYB1PUSH	1	WPA & WPA2	11 minutes ago	
00:03:7F:00:00:01	MYB1	1	WPA2	15 minutes ago	
00:1A:DD:B9:60:88	PEPWAVE_CB7E	1	WPA & WPA2	5 minutes ago	
00:1A:DD:BB:09:C1	Micro_S1_1	6	WPA & WPA2	1 hour ago	
00:1A:DD:BB:52:A8	MAX HD2 Gobi	11	WPA & WPA2	2 minutes ago	
00:1A:DD:BF:75:81	PEPLINK_05B5	4	WPA & WPA2	1 minute ago	
00:1A:DD:BF:75:82	LK_05B5	4	WPA2	1 minute ago	
00:1A:DD:BF:75:83	LK_05B5_VLAN22	4	WPA2	1 minute ago	
00:1A:DD:C1:ED:E4	dev_captive_portal_test	1	WPA & WPA2	3 minutes ago	
00:1A:DD:C2:E4:C5	PEPWAVE_7052	11	WPA & WPA2	2 hours ago	
00:1A:DD:C3:F1:64	dev_captive_portal_test	6	WPA & WPA2	6 minutes ago	
00:1A:DD:C4:DC:24	ssid_test	8	WPA & WPA2	2 minutes ago	
00:1A:DD:C4:DC:25	SSID New	8	WPA & WPA2	2 minutes ago	
00:1A:DD:C5:46:04	Guest SSID	9	WPA2	2 minutes ago	
00:1A:DD:C5:47:04	PEPWAVE_67B8	1	WPA & WPA2	5 minutes ago	
00:1A:DD:C5:4E:24	G BR1 Portal	2	WPA2	2 minutes ago	
00:1A:DD:C6:9A:48	ssid_test	8	WPA & WPA2	2 hours ago	

Nearby Devices

Hovering over the device MAC address will result in a popup with information on how this device was detected. Click the icons and the device will be moved to the bottom table of identified devices.

11.2.6 Event Log

You can access the AP Controller Event log by navigating to **AP > Controller Status > Event Log**.

Filter	
Search key	<input type="text" value="Client MAC Address / Wireless SSID / AP Serial Number / AP Profile Name"/>
Time	From <input type="text" value=""/> hh:mm to <input type="text" value=""/> hh:mm
Alerts only	<input type="checkbox"/>
<input type="button" value="Search"/>	

Events		View Alerts
Jan 2 11:01:11	AP One 300M: Client 54:EA:A0:2D:A0:D5 disassociated from Marketing_11a	
Jan 2 11:00:42	AP One 300M: Client 54:EA:A0:2D:A0:D5 associated with Marketing_11a	
Jan 2 11:00:38	AP One 300M: Client 54:EA:A0:2D:A0:D5 disassociated from Marketing_11a	
Jan 2 11:00:36	AP One 300M: Client 00:11:6A:36:09:A8 associated with Balance_11a	
Jan 2 11:00:20	AP One 300M: Client 00:07:20:06:4C disassociated from Marketing_11a	
Jan 2 11:00:09	AP One 300M: Client 54:EA:A0:2D:A0:D5 associated with Marketing_11a	
Jan 2 10:59:09	AP One 300M: Client 00:21:6A:36:09:A8 disassociated from Balance_11a	
Jan 2 10:59:08	Office Fiber AP: Client 18:00:2D:0C:48:7F associated with Balance	
Jan 2 10:58:53	Michael's Desk: Client 18:00:2D:0C:48:7F disassociated from Wireless	
Jan 2 10:58:18	AP One 300M: Client 54:EA:A0:2D:A0:D5 disassociated from Marketing_11a	
Jan 2 10:58:03	Office InWall: Client 32:8F:48:89:78:C7 associated with Wireless	
Jan 2 10:57:47	AP One 300M: Client 54:EA:A0:2D:A0:D5 associated with Marketing_11a	
Jan 2 10:57:19	AP One 300M: Client 54:EA:A0:2D:A0:D5 disassociated from Marketing_11a	
Jan 2 10:57:09	AP One 300M: Client 54:EA:A0:2D:A0:D5 associated with Marketing_11a	
Jan 2 10:56:48	AP One 300M: Client 54:EA:A0:2D:A0:D5 disassociated from Marketing_11a	
Jan 2 10:56:39	AP One 300M: Client 54:EA:A0:2D:A0:D5 associated with Marketing_11a	
Jan 2 10:56:19	AP One 300M: Client 00:28:5B:05:84:A4 associated with Marketing_11a	
Jan 2 10:56:09	AP One 300M: Client 9C:04:8B:10:39:4C associated with Marketing_11a	
Jan 2 10:55:42	AP One 300M: Client 54:EA:A0:2D:A0:D5 disassociated from Marketing_11a	
Jan 2 10:55:29	AP One 300M: Client 54:EA:A0:2D:A0:D5 associated with Marketing_11a	

[More...](#)

Events

This event log displays all activity on your AP network, down to the client level. Use to filter box to search by MAC address, SSID, AP Serial Number, or AP Profile name. Click **View Alerts** to see only alerts, and click the **More...** link for additional records.

11.3 Toolbox

Additional tools for managing firmware packs, power adjustment, and channel assignment can be found at **AP>Toolbox**.

Firmware Packs

Auto Power Adj.

Dynamic Channel Assignment

Pack ID	Release Date	Details	Action
1126	2013-08-26		

Check for Updates

Manual Upload

Default...

No default defined.

Firmware Packs

This is the first menu that will appear. Here, you can manage the firmware of your AP. Clicking on will display information regarding each firmware pack. To receive new firmware packs, you can either press **Check for Updates** to download new packs or you can press **Manual Upload** to manually upload a firmware pack. Press **Default...** to define which firmware pack is default.

12 System Tab

12.1 System

12.1.1 Admin Security

Admin Settings	
Router Name	1818-1818-1818 hostname: 1818-1818-1818
Admin User Name	admin
Admin Password	••••••••
Confirm Admin Password	••••••••
Read-only User Name	user
User Password	
Confirm User Password	
Front Panel Passcode	<input type="checkbox"/>
Web Session Timeout	4 Hours 0 Minutes
Authentication by RADIUS	<input checked="" type="checkbox"/> Enable
Auth Protocol	MS-CHAP v2
Auth Server	<input type="text"/> Port <input type="text"/> Default
Auth Server Secret	<input type="text"/> <input checked="" type="checkbox"/> Hide Characters
Auth Timeout	3 seconds
Accounting Server	<input type="text"/> Port <input type="text"/> Default
Accounting Server Secret	<input type="text"/> <input checked="" type="checkbox"/> Hide Characters
Restricted Admin Access	<input type="checkbox"/> by Management Port Only
CLI SSH	<input checked="" type="checkbox"/> Enable
CLI SSH Port	8822 Default
CLI SSH Access	LAN/WAN
Security	HTTP
Web Admin Port	80 Default
Web Admin Access	LAN/WAN

Admin Settings	
Router Name	This field allows you to define a name for this Peplink Balance unit. By default, Router Name is set as Balance_XXXX , where XXXX refers to the last 4 digits of the serial number of that balance unit.
Admin User Name	Admin User Name is set as admin by default, but can be changed, if desired.

Admin Password	This field allows you to specify a new administrator password.
Confirm Admin Password	This field allows you to verify and confirm the new administrator password.
Read-only User Name	Read-only User Name is set as user by default, but can be changed, if desired.
User Password	This field allows you to specify a new user password. Once the user password is set, the read-only user feature will be enabled.
Confirm User Password	This field allows you to verify and confirm the new user password.
Front Panel Passcode	To require a 4-digit passcode to access front panel controls, check this box and then select the code from the drop-down menus.
Web Session Timeout	This field specifies the number of hours and minutes that a web session can remain idle before the Balance terminates its access to the web admin interface. By default, it is set to 4 hours .
Authentication by RADIUS	With this box is checked, the web admin will authenticate using an external RADIUS server. Authenticated users are treated as either "admin" with full read-write permission or "user" with read-only access. Local admin and user accounts will be disabled. When the device is not able to communicate with the external RADIUS server, local accounts will be enabled again for emergency access. Additional authentication options will be available once this box is checked.
Auth Protocol	This specifies the authentication protocol used. Available options are MS-CHAP v2 and PAP .
Auth Server	This specifies the access address and port of the external RADIUS server.
Auth Server Secret	This field is for entering the secret key for accessing the RADIUS server.
Auth Timeout	This option specifies the time value for authentication timeout.
Accounting Server	This specifies the access address and port of the external accounting server.
Accounting Server Secret	This field is for entering the secret key for accessing the accounting server.
Network Connection	This option is for specifying the network connection to be used for authentication. Users can choose from LAN, WAN, and VPN connections.

Restricted Admin Access	Check this box to restrict management to administrators connected to the management port.
CLI SSH & Console	The CLI (command line interface) can be accessed via SSH. It can also be accessed from the serial console port on some Peplink Balance models. This field enables CLI support. For additional information regarding CLI, please refer to Section 22.5 .
CLI SSH Port	This field determines the port on which clients can access CLI SSH.
CLI SSH Access	This menu allows you to choose between granting access to LAN and WAN clients, or to LAN clients only.
Security	<p>This option is for specifying the protocol(s) through which the web admin interface can be accessed:</p> <ul style="list-style-type: none"> • HTTP • HTTPS • HTTP/HTTPS
Web Admin Port	This field is for specifying the port number on which the web admin interface can be accessed.
Web Admin Access	<p>This option is for specifying the network interfaces through which the web admin interface can be accessed:</p> <ul style="list-style-type: none"> • LAN only • LAN/WAN <p>If LAN/WAN is chosen, the WAN Connection Access Settings form will be displayed.</p>



LAN Connection Access Settings	
Allowed LAN Networks	This field allows you to permit only specific networks or VLANs to access the Web UI.

12.1.2 Firmware

The firmware of Peplink Balance is upgradeable through the web admin interface. Firmware upgrade functionality is located at **System>Firmware**.

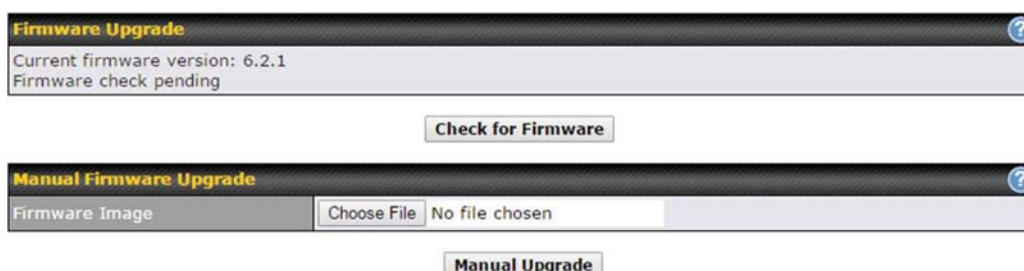

There are two ways to upgrade the unit. The first method is through an online download. The second method is to upload a firmware file manually.

To perform an online download, click on the **Check for Firmware** button. The Peplink Balance will check online for new firmware. If new firmware is available, the Peplink Balance will automatically download the firmware. The rest of the upgrade process will be automatically initiated.

You may also download a firmware image from the Peplink website and update the unit manually. To update using a firmware image, click **Choose File** to select the firmware file from the local computer, and then click **Manual Upgrade** to send the firmware to the Peplink Balance. It will then automatically initiate the firmware upgrade process.

Please note that all Peplink devices can store two different firmware versions in two different partitions. A firmware upgrade will always replace the inactive partition. If you want to keep the inactive firmware, you can simply reboot your device with the inactive firmware and then perform the firmware upgrade.

Firmware Upgrade Status

Status LED Information during firmware upgrade:

- OFF – Firmware upgrade in progress (DO NOT disconnect power.)
- Red – Unit is rebooting
- Green – Firmware upgrade successfully completed

Important Note

The firmware upgrade process may not necessarily preserve the previous configuration, and the behavior varies on a case-by-case basis. Consult the release notes for the particular firmware version before installing. Do not disconnect the power during firmware upgrade process. Do not attempt to upload a non-firmware file or a firmware file that is not supported by Peplink. Upgrading the Peplink Balance with an invalid firmware file will damage the unit and may void the warranty.

12.1.3 Time

The time server functionality enables the system clock of the Peplink Balance to be

synchronized with a specified time server. The settings for time server configuration are located at **System>Time**.

Time Settings	
Time Zone	(GMT+07:00) Krasnoyarsk <input type="checkbox"/> Show all
Time Server	0.peplink.pool.ntp.org <input type="button" value="Default"/>
<input type="button" value="Save"/>	

Time Settings	
Time Zone	This specifies the time zone (along with the corresponding Daylight Savings Time scheme) in which Peplink Balance operates. The Time Zone value affects the time stamps in the event log of the Peplink Balance and e-mail notifications. Check Show all to show all time zone options.
Time Server	This setting specifies the NTP network time server to be utilized by the Peplink Balance.

12.1.4 Schedule

Enable and disable different functions (such as WAN connections, outbound policy, and firewalls) at different times, based on a user-scheduled configuration profile. The settings for this are located at **System > Schedule**

Schedule			
Enabled			<input type="button" value="✎"/>
Name	Time	Used by	
Weekdays Only	Weekdays only	-	<input type="button" value="✕"/>
<input type="button" value="New Schedule"/>			

Enable scheduling, and then click on your schedule name or on the **New Schedule** button to begin.

Edit schedule profile ✕

Schedule Settings

Enable	<input checked="" type="checkbox"/> <small>The schedule function of those associated features will be lost if profile is disabled.</small>
Name	<input type="text" value="Weekdays Only"/>
Schedule	<input style="border: none; border-bottom: 1px solid black; background: none; width: 100%;" type="text" value="Weekdays only"/>
Used by	<small>You may go to supported feature settings page and set this profile as scheduler.</small>

Schedule Map

	Midnight				4am				8am				Noon				4pm				8pm			
Sunday	x	x	x	x	x	x	x	x	x	x	x	x	x	x	x	x	x	x	x	x	x	x	x	x
Monday	✓	✓	✓	✓	✓	✓	✓	✓	✓	✓	✓	✓	✓	✓	✓	✓	✓	✓	✓	✓	✓	✓	✓	✓
Tuesday	✓	✓	✓	✓	✓	✓	✓	✓	✓	✓	✓	✓	✓	✓	✓	✓	✓	✓	✓	✓	✓	✓	✓	✓
Wednesday	✓	✓	✓	✓	✓	✓	✓	✓	✓	✓	✓	✓	✓	✓	✓	✓	✓	✓	✓	✓	✓	✓	✓	✓
Thursday	✓	✓	✓	✓	✓	✓	✓	✓	✓	✓	✓	✓	✓	✓	✓	✓	✓	✓	✓	✓	✓	✓	✓	✓
Friday	✓	✓	✓	✓	✓	✓	✓	✓	✓	✓	✓	✓	✓	✓	✓	✓	✓	✓	✓	✓	✓	✓	✓	✓
Saturday	x	x	x	x	x	x	x	x	x	x	x	x	x	x	x	x	x	x	x	x	x	x	x	x

Edit Schedule Profile	
Enabling	Click this checkbox to enable this schedule profile. Note that if this is disabled, then any associated features will also have their scheduling disabled.
Name	Enter your desired name for this particular schedule profile.
Schedule	Click the drop-down menu to choose pre-defined schedules as your starting point. Please note that upon selection, previous changes on the schedule map will be deleted.
Schedule Map	Click on the desired times to enable features at that time period. You can hold your mouse for faster entry.

12.1.5 Email Notification

The email notification functionality of the Peplink Balance provides a system administrator with up-to-date information on network status. The settings for configuring email notification are found at **System>Email Notification**.

Email Notification Settings	
Email Notification	This setting specifies whether or not to enable email notification. If Enable is checked, the Peplink Balance will send email messages to system administrators when the WAN status changes or when new firmware is available. If Enable is not checked, email notification is disabled and the Peplink Balance will not send email messages.

SMTP Server	This setting specifies the SMTP server to be used for sending email. If the server requires authentication, check Require authentication .
SSL Encryption	Check the box to enable SMTPS. When the box is checked, SMTP Port will be changed to 465 automatically.
SMTP Port	This field is for specifying the SMTP port number. By default, this is set to 25 ; when SSL Encryption is checked, the default port number will be set to 465 . You may customize the port number by editing this field. Click Default to restore the number to its default setting.
SMTP User Name / Password	This setting specifies the SMTP username and password while sending email. These options are shown only if Require authentication is checked in the SMTP Server setting.
Confirm SMTP Password	This field allows you to verify and confirm the new administrator password.
Sender's Email Address	This setting specifies the email address which the Peplink Balance will use to send its reports.
Recipient's Email Address	This setting specifies the email address(es) to which the Peplink Balance will send email notifications. For multiple recipients, separate each email using the enter key.

After you have finished setting up email notifications, you can click the **Test Email Notification** button to test the settings before saving. After **Test Email Notification** is clicked, you will see this screen to confirm the settings:

Test Email Notification	
SMTP Server	smtp.mycompany.com
SMTP Port	465
SMTP UserName	smtpuser
Sender's Email Address	admin@mycompany.com
Recipient's Email Address	system@mycompany.com staff@mycompany.com

Click **Send Test Notification** to confirm. In a few seconds, you will see a message with detailed test results.

Test email sent. Email notification settings are not saved, it will be saved after clicked the 'Save' button.

Test Result

```
[INFO] Try email through connection #3
[<-] 220 ESMTP
[->] EHLO balance
[<-] 250-smtp Hello balance [210.210.210.210]
250-SIZE 100000000
250-8BITMIME
250-PIPELINING
250-AUTH PLAIN LOGIN
250-STARTTLS
250-URL
```

12.1.6 Event Log

Event log functionality enables event logging at a specified remote syslog server. The settings for configuring the remote system log can be found at **System>Event Log**.

Send Events to Remote Syslog Server	
Remote Syslog	<input checked="" type="checkbox"/>
Remote Syslog Host	<input type="text"/>
Push Events to Mobile Devices	
Push Events	<input checked="" type="checkbox"/>

Remote Syslog Settings	
Remote Syslog	This setting specifies whether or not to log events at the specified remote syslog server.
Remote Syslog Host	This setting specifies the IP address or hostname of the remote syslog server.
Push Events	<p>The Peplink Balance can also send push notifications to mobile devices that have our Mobile Router Utility installed. Check the box to activate this feature.</p> <p>For more information on the Router Utility, go to: www.peplink.com/products/router-utility</p> 

12.1.7 SNMP

SNMP or simple network management protocol is an open standard that can be used to collect information about the Peplink Balance unit. SNMP configuration is located at **System>SNMP**.

SNMP Settings			
SNMP Device Name	Balance_0D84		
SNMP Port	161	<input type="button" value="Default"/>	
SNMPv1	<input type="checkbox"/> Enable		
SNMPv2c	<input type="checkbox"/> Enable		
SNMPv3	<input type="checkbox"/> Enable		
<input type="button" value="Save"/>			

Community Name	Allowed Source Network	Access Mode	
MyCompany	192.168.1.20/24	Read Only	<input type="button" value="X"/>
<input type="button" value="Add SNMP Community"/>			

SNMPv3 User Name	Authentication / Privacy	Access Mode	
SNMPUser	SHA / DES	Read Only	<input type="button" value="X"/>
<input type="button" value="Add SNMP User"/>			

SNMP Settings	
SNMP Device Name	This field shows the router name defined at System>Admin Security .
SNMP Port	This option specifies the port which SNMP will use. The default port is 161 .
SNMPv1	This option allows you to enable SNMP version 1.
SNMPv2	This option allows you to enable SNMP version 2.
SNMPv3	This option allows you to enable SNMP version 3.

To add a community for either SNMPv1 or SNMPv2, click the **Add SNMP Community** button in the **Community Name** table, upon which the following screen is displayed:

The dialog box titled "SNMP Community" contains the following fields:

Community Name	MyCompany
Allowed Network	192.168.1.25 / 255.255.255.0 (/24)

Buttons: Save, Cancel

SNMP Community Settings	
Community Name	This setting specifies the SNMP community name.
Allowed Source Subnet Address	This setting specifies a subnet from which access to the SNMP server is allowed. Enter subnet address here (e.g., 192.168.1.0) and select the appropriate subnet mask.

To define a user name for SNMPv3, click **Add SNMP User** in the **SNMPv3 User Name** table, upon which the following screen is displayed:

The dialog box titled "SNMPv3 User" contains the following fields:

User Name	SNMPUser
Authentication	SHA password
Privacy	DES privacypassword

Buttons: Save, Cancel

SNMPv3 User Settings	
User Name	This setting specifies a user name to be used in SNMPv3.
Authentication Protocol	This setting specifies via a drop-down menu one of the following valid authentication protocols: <ul style="list-style-type: none"> NONE

	<ul style="list-style-type: none"> • MD5 • SHA <p>When MD5 or SHA is selected, an entry field will appear for the password.</p>
Privacy Protocol	<p>This setting specifies via a drop-down menu one of the following valid privacy protocols:</p> <ul style="list-style-type: none"> • NONE • DES <p>When DES is selected, an entry field will appear for the password.</p>

12.1.8 InControl

InControl Management	
InControl Management	<input checked="" type="checkbox"/> Allow InControl Management
Privately Host InControl	<input checked="" type="checkbox"/>
InControl Host	<input type="text"/>

InControl is a cloud-based service which allows you to manage all of your Peplink and Pepwave devices with one unified system. With it, you can generate reports, gather statistics, and configure your devices automatically. All of this is now possible with InControl.

When this check box is checked, the device's status information will be sent to the Peplink InControl system. This device's usage data and configuration will be sent to the system if you enable the features in the system.

Alternately, you could also privately host InControl. Simply check the box beside the "Privately Host InControl" open, and enter the IP Address of your InControl Host.

You can sign up for an InControl account at <https://incontrol2.peplink.com>. You can register your devices under the account, monitor their status, see their usage reports, and receive offline notifications.

12.1.9 Configuration

Backing up Peplink Balance settings immediately after successful completion of initial setup is strongly recommended. The functionality to download and upload Peplink Balance settings is found at **System>Configuration**.

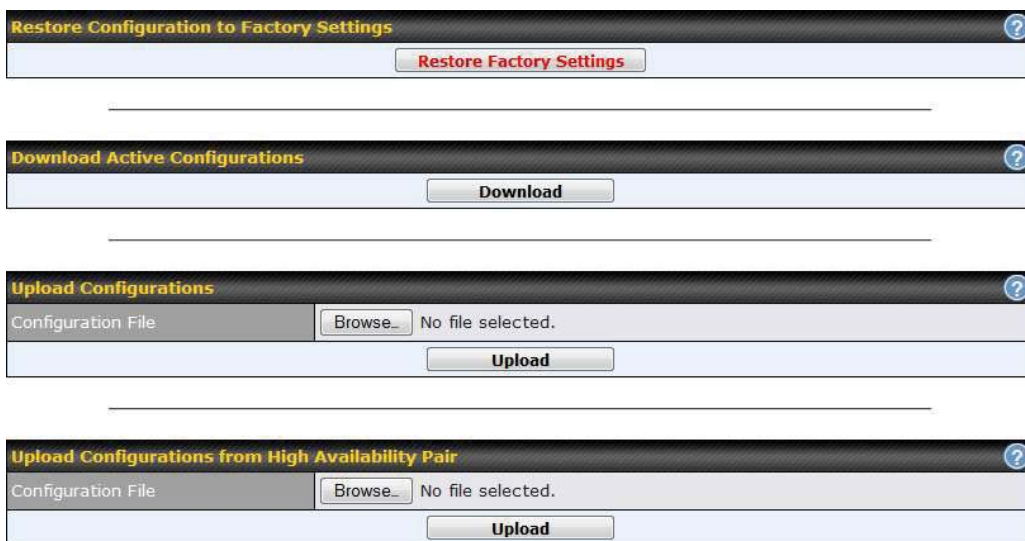

Configuration	
Restore Configuration to Factory Settings	The Restore Factory Settings button is to reset the configuration to factory default settings. After clicking the button, you will need to click the Apply Changes button on the top right corner to make the settings effective.
Download Active Configurations	Click Download to backup the current active settings.
Upload Configurations	To restore or change settings based on a configuration file, click Choose File to locate the configuration file on the local computer, and then click Upload . The new settings can then be applied by clicking the Apply Changes button on the page header, or you can cancel the procedure by pressing discard on the main page of the web admin interface.
Upload Configurations	In a high availability (HA) configuration, the Balance unit can quickly load the configuration of its HA counterpart. To do so, click the Upload button. After loading the settings, configure the LAN IP address of the Peplink Balance unit so that it is different from the HA

from High Availability Pair counterpart.

12.1.10 Feature Add-ons

Some balance models have features that can be activated upon purchase. Once the purchase is complete, you will receive an activation key. Enter the key in the **Activation Key** field, click **Activate**, and then click **Apply Changes**.

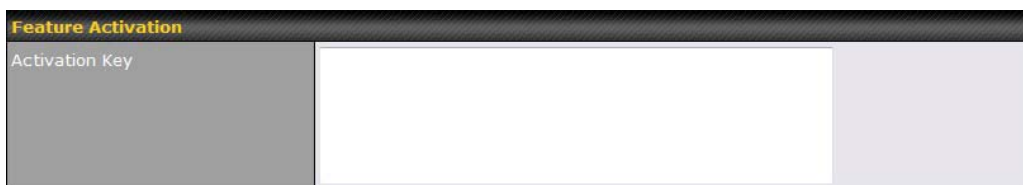

The screenshot shows a web interface for feature activation. At the top, there is a dark header with the text 'Feature Activation' in yellow. Below the header, on the left, is a grey box with the text 'Activation Key'. To the right of this box is a large, empty white rectangular input field for entering the activation key.

12.1.11 Reboot

This page provides a reboot button for restarting the system. For maximum reliability, the Peplink Balance Series can equip with two copies of firmware, and each copy can be a different version. You can select the firmware version you would like to reboot the device with. The firmware marked with **(Running)** is the current system boot up firmware.

Please note that a firmware upgrade will always replace the inactive firmware partition.



The screenshot shows a web interface for rebooting the system. At the top, there is a dark header with the text 'Reboot System' in yellow and a blue question mark icon on the right. Below the header, it says 'Select the firmware you want to use to start up this device:'. There are two radio button options: 'Firmware 1: 6.2.1 build 2977 (Running)' and 'Firmware 2: 6.2.1b01 build 2949'. At the bottom, there is a button labeled 'Reboot'.

12.2 Tools

12.3 Ping

The ping test tool sends pings through a specific Ethernet interface or a SpeedFusion™ VPN connection. You can specify the number of pings in the field **Number of times** to a maximum number of 10 times. **Packet Size** can be set to a maximum of 1472 bytes. The ping utility is located at **System>Tools>Ping**, illustrated below:

Ping	
Connection	WAN 1
Destination	10.10.10.1
Packet Size	56
Number of times	Times 5

Results	
PING 10.10.10.1 (10.10.10.1) from 10.91.137.1 56(84) bytes of data.	
64 bytes from 10.10.10.1: icmp_req=1 ttl=59 time=28.5 ms	
64 bytes from 10.10.10.1: icmp_req=2 ttl=59 time=30.7 ms	
64 bytes from 10.10.10.1: icmp_req=3 ttl=59 time=29.3 ms	
64 bytes from 10.10.10.1: icmp_req=4 ttl=59 time=28.8 ms	
64 bytes from 10.10.10.1: icmp_req=5 ttl=59 time=29.2 ms	
--- 10.10.10.1 ping statistics ---	
5 packets transmitted, 5 received, 0% packet loss, time 4003ms	
rtt min/avg/max/mdev = 28.536/29.357/30.781/0.792 ms	

Tip

A system administrator can use the ping utility to manually check the connectivity of a particular LAN/WAN connection.

12.4 Traceroute

The traceroute test tool traces the routing path to the destination through a particular Ethernet interface or a SpeedFusion™ connection. The traceroute test utility is located at **System>Tools>Traceroute**.

Traceroute	
Connection	WAN 1
Destination	64.233.189.99
<input type="button" value="Start"/> <input type="button" value="Stop"/>	

Results		Clear Log
<pre> 1 10.0.0.1 [10.0.0.1] 0.000 ms 2 10.0.0.1 [10.0.0.1] 0.000 ms 3 10.0.0.1 [10.0.0.1] 0.000 ms 4 10.0.0.1 [10.0.0.1] 0.000 ms 5 10.0.0.1 [10.0.0.1] 0.000 ms 6 10.0.0.1 [10.0.0.1] 0.000 ms 7 10.0.0.1 [10.0.0.1] 0.000 ms 8 10.0.0.1 [10.0.0.1] 0.000 ms 9 10.0.0.1 [10.0.0.1] 0.000 ms 10 10.0.0.1 [10.0.0.1] 0.000 ms 11 10.0.0.1 [10.0.0.1] 0.000 ms 12 10.0.0.1 [10.0.0.1] 0.000 ms 13 10.0.0.1 [10.0.0.1] 0.000 ms 14 10.0.0.1 [10.0.0.1] 0.000 ms 15 10.0.0.1 [10.0.0.1] 0.000 ms 16 10.0.0.1 [10.0.0.1] 0.000 ms 17 10.0.0.1 [10.0.0.1] 0.000 ms 18 10.0.0.1 [10.0.0.1] 0.000 ms 19 10.0.0.1 [10.0.0.1] 0.000 ms 20 10.0.0.1 [10.0.0.1] 0.000 ms </pre>		

Tip

A system administrator can use the traceroute utility to analyze the connection path of a LAN/WAN connection.

12.5 Wake-on-LAN

Peplink routers can send special “magic packets” to any client specified from the Web UI. To access this feature, navigate to **System > Tools > Wake-on-LAN**

Wake-on-LAN	
Wake-on-LAN Target	Surf_SOHO (00:90:90:90:90:90) <input type="button" value="Send"/>

Select a client from the drop-down list and click **Send** to send a “magic packet”

12.6 CLI (Command Line) Support

The serial console connector on some Peplink Balance units is RJ-45. To access the serial console port, prepare a RJ-45 to DB-9 console cable. Connect the RJ-45 end to the unit's console port and the DB-9 end to a terminal's serial port. The port setting will be *115200,8N1*.

The serial console connector on other Peplink Balance units is a DB-9 male connector. To access the serial console port, connect a null modem cable with a DB-9 connector on both ends to a terminal with the port setting of *115200,8N1*.

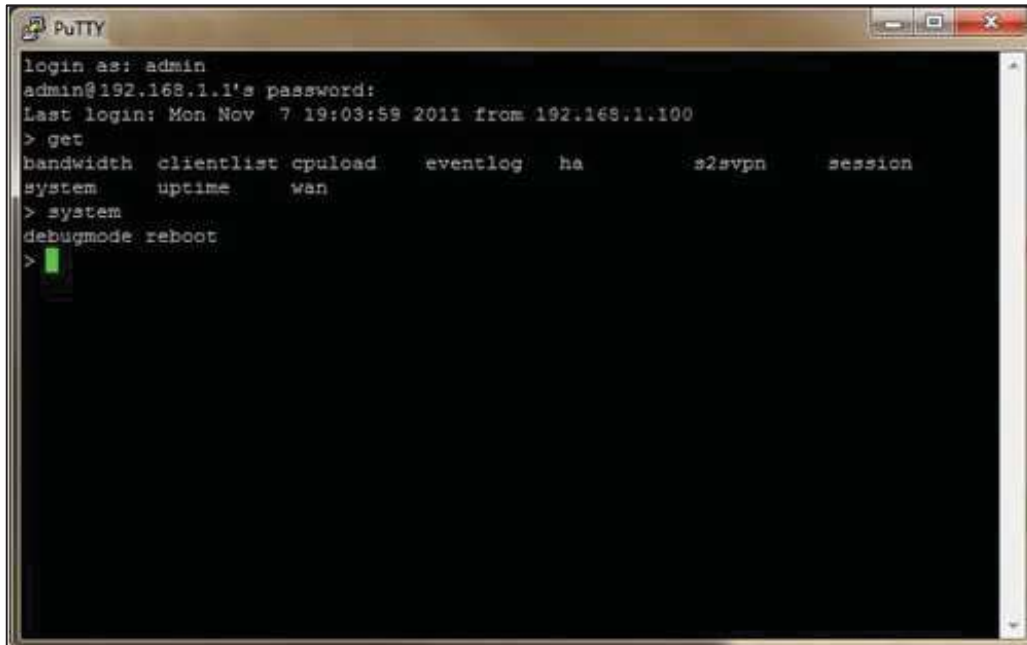

```
login as: admin
admin@192.168.1.1's password:
Last login: Mon Nov  7 19:03:59 2011 from 192.168.1.100
> get
bandwidth  clientlist  cpuload  eventlog  ha  s2svpn  session
system    uptime    wan
> system
debugmode reboot
>
```

13 Status Tab

13.1 Status

13.1.1 Device

System information is located at **Status>Device**.

System Information	
Router Name	1818-1818-1818
Model	Peplink Balance 30
Hardware Revision	2
Serial Number	1818-1818-1818
Firmware	6.2.1 build 2977
PepVPN Version	4.0.0
Modem Support Version	1018 (Modem Support List)
Host Name	1818-1818-1818
Uptime	8 days 1 hour 12 minutes
System Time	Sun Jun 21 07:51:07 WET 2015
Diagnostic Report	Download
Remote Assistance	Turn on

Interface	MAC Address
LAN	10:56:56:56:56:BC
WAN 1	10:56:56:56:56:BD
WAN 2	10:56:56:56:56:BE
WAN 3	10:56:56:56:56:BF

System Information	
Router Name	This is the name specified in the Router Name field located at System>Admin Security .
Model	This shows the model name and number of this device.
Hardware Revision	This shows the hardware version of this device.
Serial Number	This shows the serial number of this device.
Firmware	This shows the firmware version this device is currently running.
Uptime	This shows the length of time since the device has been rebooted.
System Time	This shows the current system time.
Diagnostic Report	The Download link is for exporting a diagnostic report file required for system investigation.
Remote Assistance	Click Turn on to enable remote assistance.

The second table shows the MAC address of each LAN/WAN interface connected.

Important Note
If you encounter issues and would like to contact the Peplink Support Team (http://www.peplink.com/contact/), please download the diagnostic report file and attach it along with a description of your issue. In Firmware 5.1 or before, the diagnostic report file can be obtained at System>Reboot .

13.1.2 Active Sessions

Information on active sessions can be found at **Status>Active Sessions>Overview**.

Service	Inbound Sessions	Outbound Sessions
AIM/ICQ	0	1
Bittorrent	0	32
DNS	0	51
Flash	0	1
HTTPS	0	76
Jabber	0	5
MSN	0	11
NTP	0	4
QQ	0	1
Remote Desktop	0	3
SSH	0	12
SSL	0	64
XMPP	0	4
Yahoo	0	1

Interface	Inbound Sessions	Outbound Sessions
WAN1	0	219
WAN2	0	0
WAN3	0	0
Mobile Internet	0	0

Top Clients

Client IP Address	Total Sessions
10.9.66.66	1069
10.9.98.144	147
10.9.2.18	63
10.9.66.14	56
10.9.2.26	33

This screen displays the number of sessions initiated by each application. Click on each service listing for additional information. This screen also indicates the number of sessions initiated by each WAN port. Finally, you can see which clients are initiating the most sessions.

In addition, you can also perform a filtered search for specific sessions. You can filter by subnet, port, protocol, and interface. To perform a search, navigate to **Status>Active Sessions>Search**.

Overview

Search

Session data captured 1 min ago. [Refresh](#)

IP / Subnet	Source or Destination ▾ / 255.255.255.255 (/32) ▾
Port	Source or Destination ▾
Protocol / Service	SSL ▾
Interface	<input type="checkbox"/> 1 WAN 1 <input type="checkbox"/> 2 WAN 2 <input type="checkbox"/> 3 WAN 3 <input type="checkbox"/> 4 WAN 4 <input type="checkbox"/> 5 WAN 5 <input type="checkbox"/> 6 WAN 6 <input type="checkbox"/> 7 WAN 7 <input type="checkbox"/> 8 WAN 8 <input type="checkbox"/> 9 WAN 9 <input type="checkbox"/> 10 WAN 10 <input type="checkbox"/> 11 WAN 11 <input type="checkbox"/> 12 WAN 12 <input type="checkbox"/> Mobile Internet <input type="checkbox"/> VPN

Outbound

Protocol	Source IP	Destination IP	Service	Interface	Idle Time
No sessions					

Total searched results: 0

Inbound

Protocol	Source IP	Destination IP	Service	Interface	Idle Time
No sessions					

Total searched results: 0

Transit

Protocol	Source IP	Destination IP	Service	Interface	Idle Time
No sessions					







Total searched results: 0

This **Active Sessions** section displays the active inbound / outbound sessions of each WAN connection on the Peplink Balance. A filter is available to help sort out the active session information. Enter a keyword in the field or check one of the WAN connection boxes for filtering.

13.1.3 Client List

The client list table is located at **Status>Client List**. It lists DHCP and online client IP addresses, names (retrieved from the DHCP reservation table or defined by users), current download and upload rate, and MAC address.

Clients can be imported into the DHCP reservation table by clicking the button on the right. Further update the record after the import by going to **Network>LAN**.

Filter		<input type="checkbox"/> Online Clients Only	<input type="checkbox"/> DHCP Clients Only		
Client List					
IP Address ▲	Name	Download (kbps)	Upload (kbps)	MAC Address	Import
 192.168.167.10		0	0	10:56:56:198:167:10	
 192.168.167.11	U64-2-1	0	0	00:50:56:198:167:11	
 192.168.167.12	U64-2-2	0	0	10:56:56:198:167:12	

If the PPTP server SpeedFusion™, or AP controller is enabled, you may see the corresponding connection name listed in the **Name** field.

13.1.4 WINS Clients

The WINS client list table is located at **Status>WINS Client**.

WINS Client List	
Name ▲	IP Address
UserA	10.9.2.1
UserB	10.9.30.1
UserC	10.9.2.4

Flush All

The WINS client table lists the IP addresses and names of WINS clients. This option will only be available when you have enabled the WINS server. The names of clients retrieved will be automatically matched into the Client List (see previous section). Click **Flush All** to flush all WINS client records.

13.1.5 OSPF & RIPv2

Information on OSPF and RIPv2 routing setup can be found at **Status>OSPF & RIPv2**.

13.1.6 MediaFast

To get details on storage and bandwidth usage, select **Status>MediaFast**.

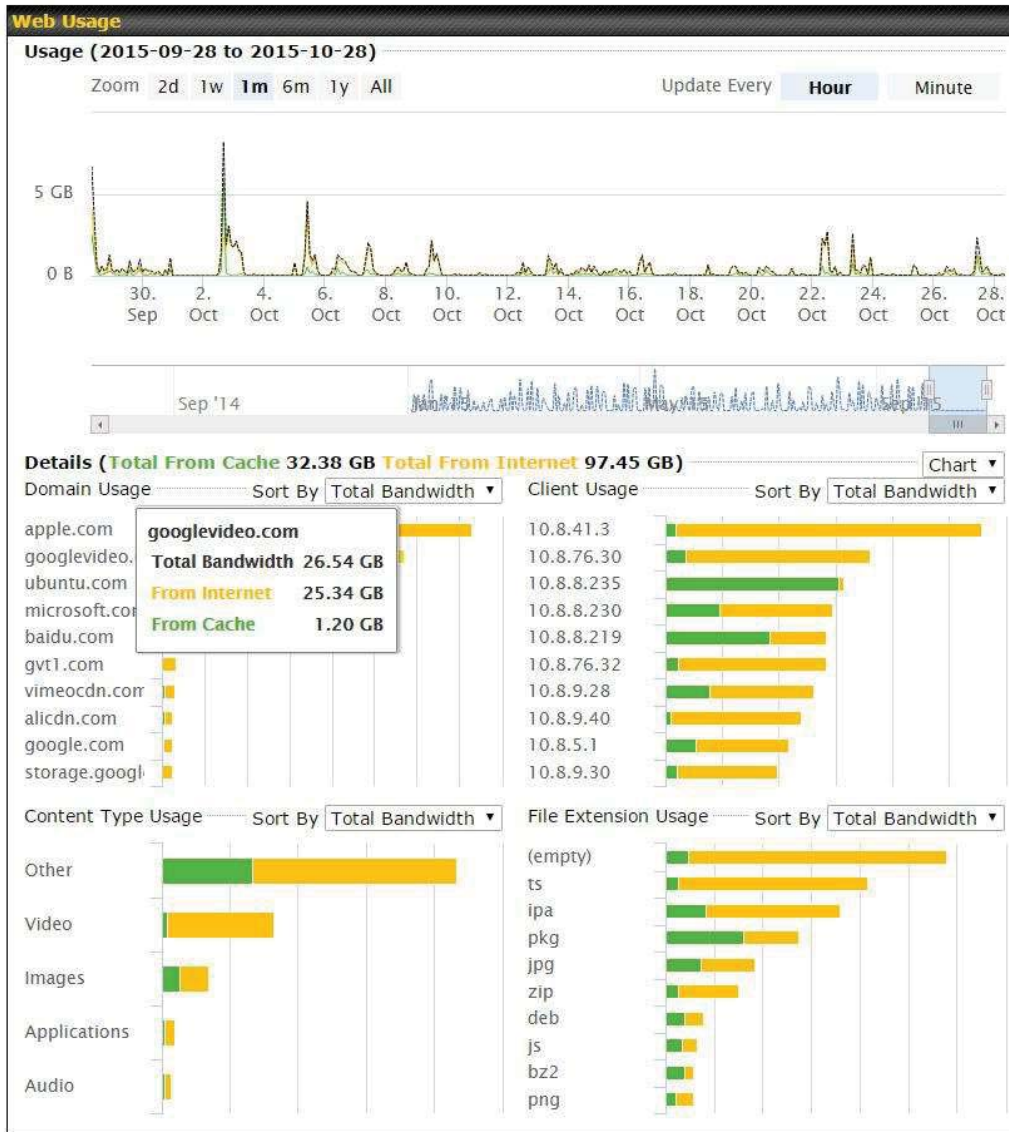

13.1.7 SpeedFusion Status

Current SpeedFusion™ status information is located at **Status>SpeedFusion™**. Details about SpeedFusion™ connection peers appears as below:

PepVPN with SpeedFusion - Remote Peer Details Show disconnected profiles

Search

Remote Peer	Profile	Information		
FFFC-FFFC-FFFC	FH	192.168.77.0/24		
3ED2-3ED2-3ED2	380-5 - NO NAT	192.168.3.0/24		

Click on the corresponding peer name to explore the WAN connection(s) status and subnet information of each VPN peer.

Remote Peer	Profile	Information		
FFFC-FFFC-FFFC	FH	192.168.77.0/24		
<ul style="list-style-type: none"> WAN 1 WAN 2 WAN 3 Total 	<ul style="list-style-type: none"> Rx: < 1 kbps Tx: < 1 kbps Drop rate: 0.0 pkt/s Latency: 1 ms 	<ul style="list-style-type: none"> Rx: < 1 kbps Tx: < 1 kbps Drop rate: 0.0 pkt/s Latency: 1 ms 	<ul style="list-style-type: none"> Rx: < 1 kbps Tx: < 1 kbps Drop rate: 0.0 pkt/s Latency: 1 ms 	<ul style="list-style-type: none"> Rx: < 1 kbps Tx: 1.1 kbps Drop rate: 0.0 pkt/s
3ED2-3ED2-3ED2	380-5 - NO NAT	192.168.3.0/24		
<ul style="list-style-type: none"> WAN 1 WAN 2 WAN 3 Total 	<ul style="list-style-type: none"> Rx: < 1 kbps Tx: < 1 kbps Drop rate: 0.0 pkt/s Latency: 4 ms 	<ul style="list-style-type: none"> Rx: < 1 kbps Tx: < 1 kbps Drop rate: 0.0 pkt/s Latency: 4 ms 	<ul style="list-style-type: none"> Rx: < 1 kbps Tx: < 1 kbps Drop rate: 0.0 pkt/s Latency: 4 ms 	<ul style="list-style-type: none"> Rx: 1.6 kbps Tx: < 1 kbps Drop rate: 0.0 pkt/s

Click the button for a chart displaying real-time throughput, latency, and drop-rate information for each WAN connection.



When pressing the  button, the following menu will appear:

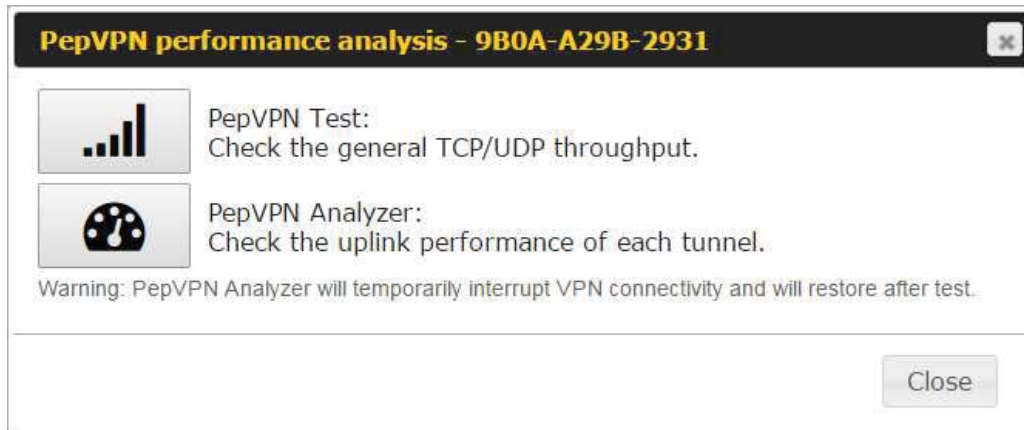

PepVPN Test:
Check the general TCP/UDP throughput.

After clicking the icon, the following menu appears:

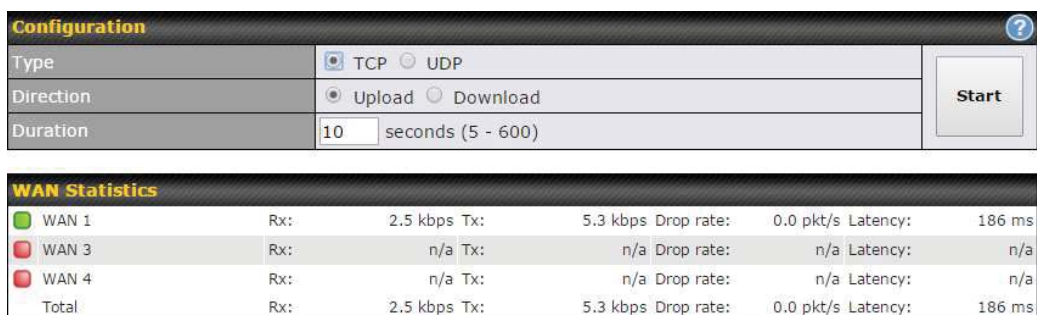

Select the L2 protocol (TCP/UDP), direction, and duration and click the **Start** button to begin the general throughput test.

Results	
0.1250 MB / 1.00 sec =	1.0485 Mbps
1.0000 MB / 1.00 sec =	8.3888 Mbps
1.3125 MB / 1.00 sec =	11.0098 Mbps
3.0000 MB / 1.00 sec =	25.1465 Mbps
5.6875 MB / 1.00 sec =	47.7473 Mbps
6.0625 MB / 1.00 sec =	50.8562 Mbps
4.9375 MB / 1.00 sec =	41.4188 Mbps
4.5000 MB / 1.00 sec =	37.7487 Mbps
5.0000 MB / 1.00 sec =	41.9438 Mbps
5.6875 MB / 1.00 sec =	47.7099 Mbps
37.3167 MB / 10.05 sec = 31.1504 Mbps 8 %TX 9 %RX 47 retrans 132.62 msRTT	
TEST DONE	



PepVPN Analyzer:
Check the uplink performance of each tunnel.

The bandwidth bonding feature of PepVPN occurs when multiple WAN lines from one end merge with multiple WAN lines from the other end. For this to happen, each WAN line needs to form a connection with all the WAN lines on the opposite end. The function of the PepVPN analyzer is to report the throughput, packet loss, and latency of all possible combinations of connections. **Please note that the PepVPN Analyzer will temporarily interrupt VPN connectivity and will restore after test.**

After clicking the icon, the analyzer will require several minutes to perform its analysis depending the number of WAN links in the SpeedFusion™ Tunnel. Once the test the complete, the report will appear:

Results ?							
Estimated time: 150 s							
Time remaining: 0 s							
100%							
Local WAN1 > Remote WAN3	Local WAN1 > Remote WAN4	Local WAN1 > Remote WAN5	Local WAN1 > Remote WAN6	Tx Avg. (Mbps)	Tx Max. (Mbps)	Packet loss (%)	RTT (ms)
0				5.87	16.95	0.76	420.51
	0			20.72	26.39	1.59	29.89
		0		30.10	43.69	2.24	29.61
			0	45.01	55.93	2.16	28.24
0	0			24.87	33.56	0.86	49.86
0		0		19.30	31.28	0.01	49.78
	0	0		18.59	30.41	2.08	39.78
0	0	0		20.56	34.60	0.00	38.11
0			0	36.70	59.16	2.64	42.06
	0		0	19.98	30.40	4.40	38.01
0	0		0	31.63	42.99	0.72	37.99
		0	0	36.88	55.78	2.60	33.89
0		0	0	38.30	47.89	0.01	29.98
	0	0	0	33.21	55.23	2.69	30.48
0	0	0	0	30.02	46.66	3.77	28.68

"0" indicates that specific WAN / Tunnel is active for that particular test.

"Tx Avg." is the averaged throughput across the full 10 seconds time, while "Tx Max." is the averaged throughput of the fastest 30% of time.

13.1.8 Event Log

Event log information is located at **Status>Event Log**.

Device Event Log

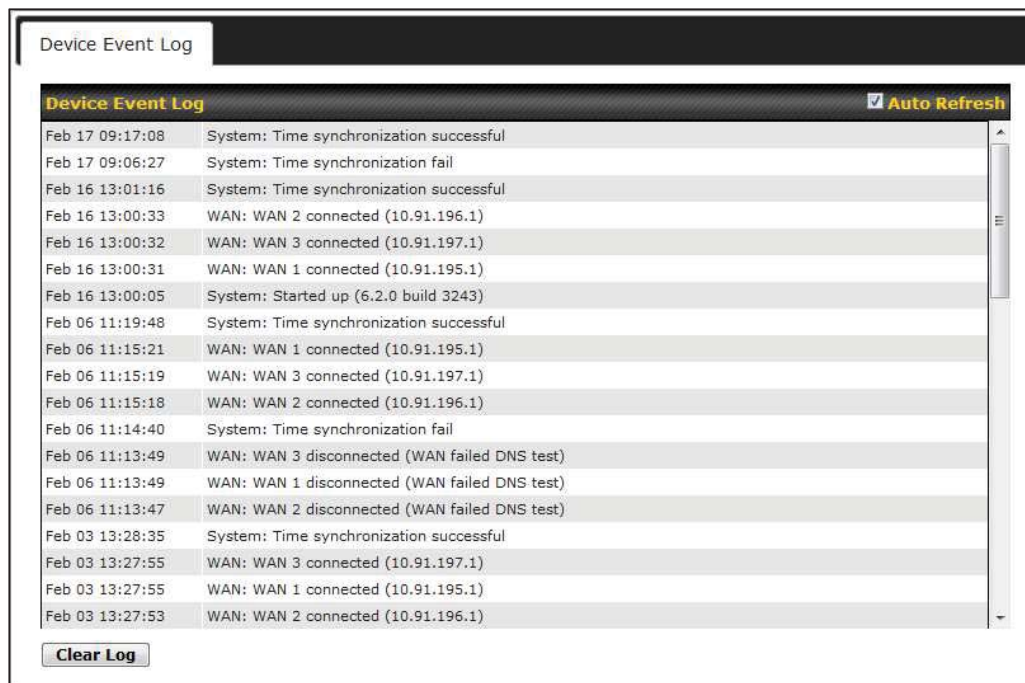

Device Event Log		<input checked="" type="checkbox"/> Auto Refresh
Feb 17 09:17:08	System: Time synchronization successful	
Feb 17 09:06:27	System: Time synchronization fail	
Feb 16 13:01:16	System: Time synchronization successful	
Feb 16 13:00:33	WAN: WAN 2 connected (10.91.196.1)	
Feb 16 13:00:32	WAN: WAN 3 connected (10.91.197.1)	
Feb 16 13:00:31	WAN: WAN 1 connected (10.91.195.1)	
Feb 16 13:00:05	System: Started up (6.2.0 build 3243)	
Feb 06 11:19:48	System: Time synchronization successful	
Feb 06 11:15:21	WAN: WAN 1 connected (10.91.195.1)	
Feb 06 11:15:19	WAN: WAN 3 connected (10.91.197.1)	
Feb 06 11:15:18	WAN: WAN 2 connected (10.91.196.1)	
Feb 06 11:14:40	System: Time synchronization fail	
Feb 06 11:13:49	WAN: WAN 3 disconnected (WAN failed DNS test)	
Feb 06 11:13:49	WAN: WAN 1 disconnected (WAN failed DNS test)	
Feb 06 11:13:47	WAN: WAN 2 disconnected (WAN failed DNS test)	
Feb 03 13:28:35	System: Time synchronization successful	
Feb 03 13:27:55	WAN: WAN 3 connected (10.91.197.1)	
Feb 03 13:27:55	WAN: WAN 1 connected (10.91.195.1)	
Feb 03 13:27:53	WAN: WAN 2 connected (10.91.196.1)	

The log section displays a list of events that has taken place on the Peplink Balance unit. Check **Auto Refresh** to refresh log entries automatically. Click the **Clear Log** button to clear the log.

IPsec Event Log

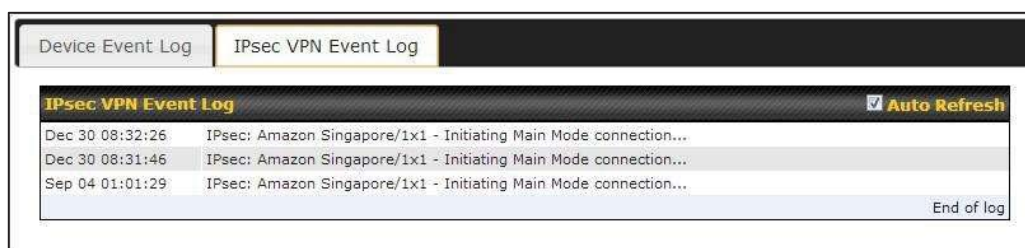

IPsec VPN Event Log		<input checked="" type="checkbox"/> Auto Refresh
Dec 30 08:32:26	IPsec: Amazon Singapore/1x1 - Initiating Main Mode connection...	
Dec 30 08:31:46	IPsec: Amazon Singapore/1x1 - Initiating Main Mode connection...	
Sep 04 01:01:29	IPsec: Amazon Singapore/1x1 - Initiating Main Mode connection...	

This section displays a list of events that has taken place within an IPsec VPN connection. Check the box next to **Auto Refresh** and the log will be refreshed automatically. For an AP event log, navigate to **AP>Info**.

13.2 Bandwidth

This section shows the bandwidth usage statistics, located at **Status>Bandwidth**.

Bandwidth usage at the LAN while the device is switched off (e.g., LAN bypass) is neither recorded nor shown.

13.2.1 Real-Time

The **Data transferred since installation** table indicates how much network traffic has been processed by the device since the first bootup. The **Data transferred since last reboot** table indicates how much network traffic has been processed by the device since the last bootup.

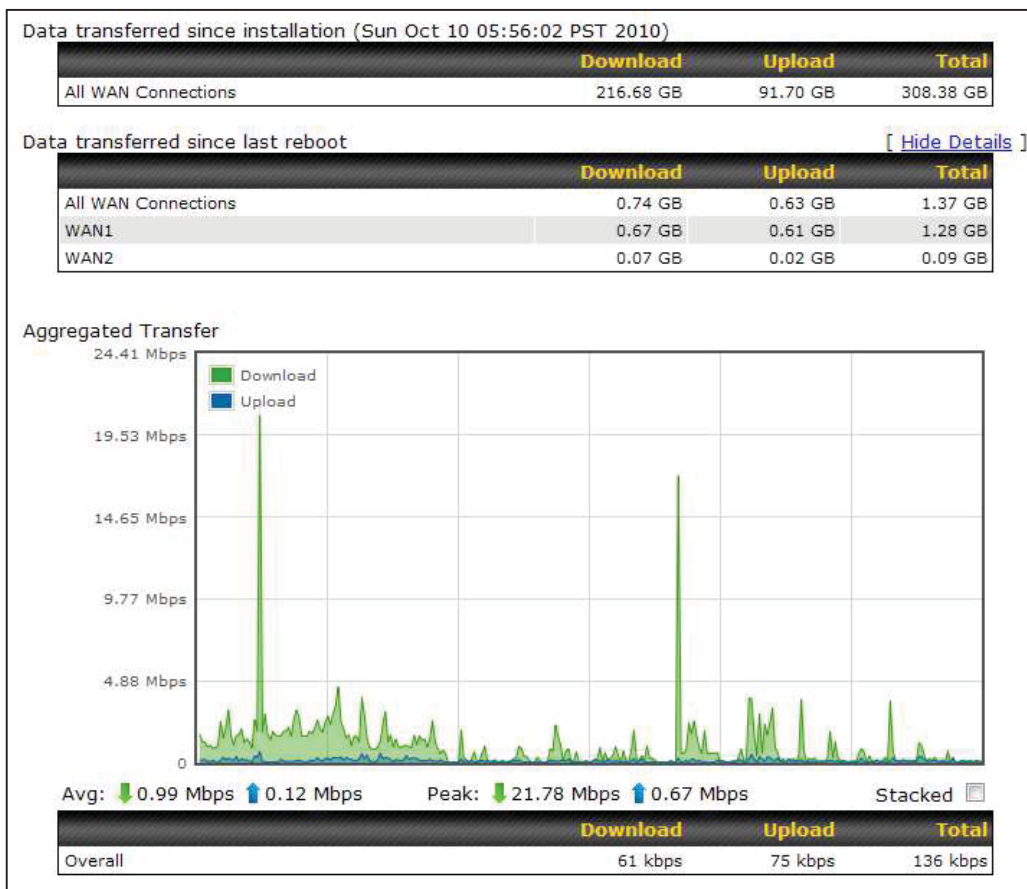

13.2.2 Hourly

This page shows the hourly bandwidth usage for all WAN connections, with the option of viewing each individual connection. Select the desired connection to check from the drop-down menu.

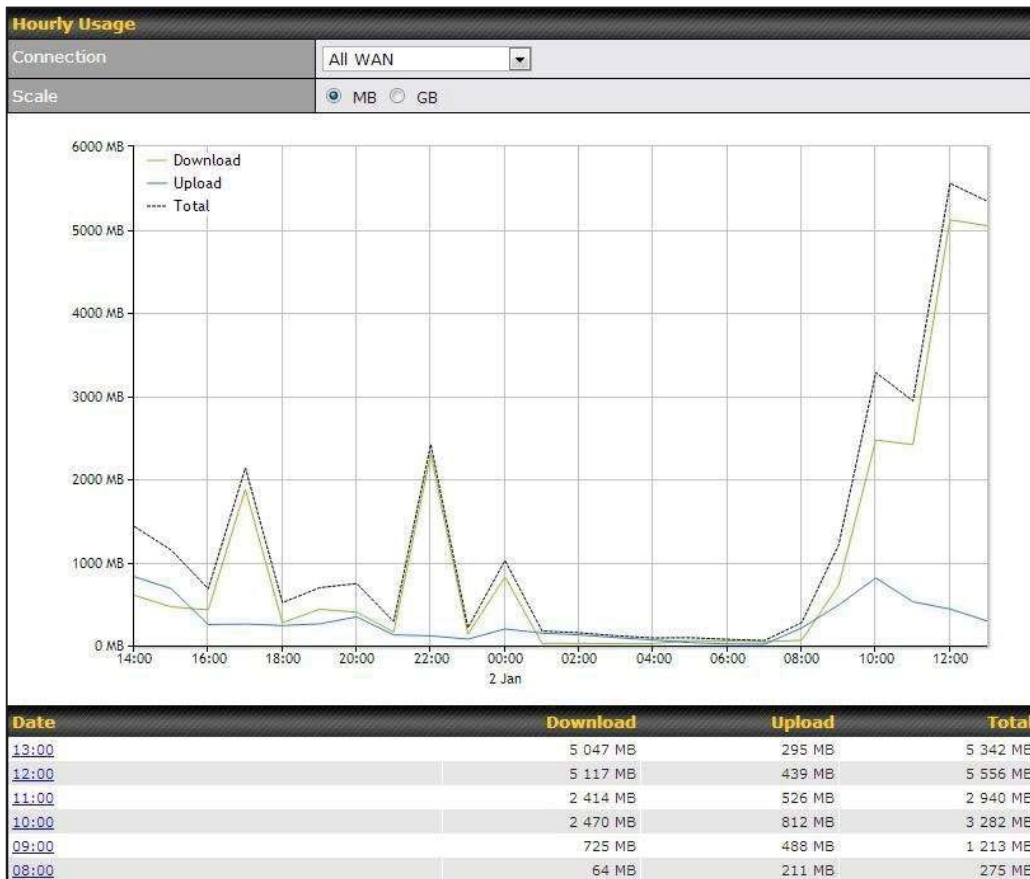

13.2.3 Daily

This page shows the daily bandwidth usage for all WAN connections, with the option of viewing each individual connection.

Select the connection to check from the drop-down menu. If you have enabled the **Bandwidth Monitoring** feature as shown in **Section 13.4**, the **Current Billing Cycle** table for that WAN connection will be displayed.

Click on a date to view the client bandwidth usage of that specific date. This feature is not available if you have selected to view the bandwidth usage of only a particular WAN connection. The scale of the graph can be set to display megabytes (**MB**) or gigabytes

(GB).



Status

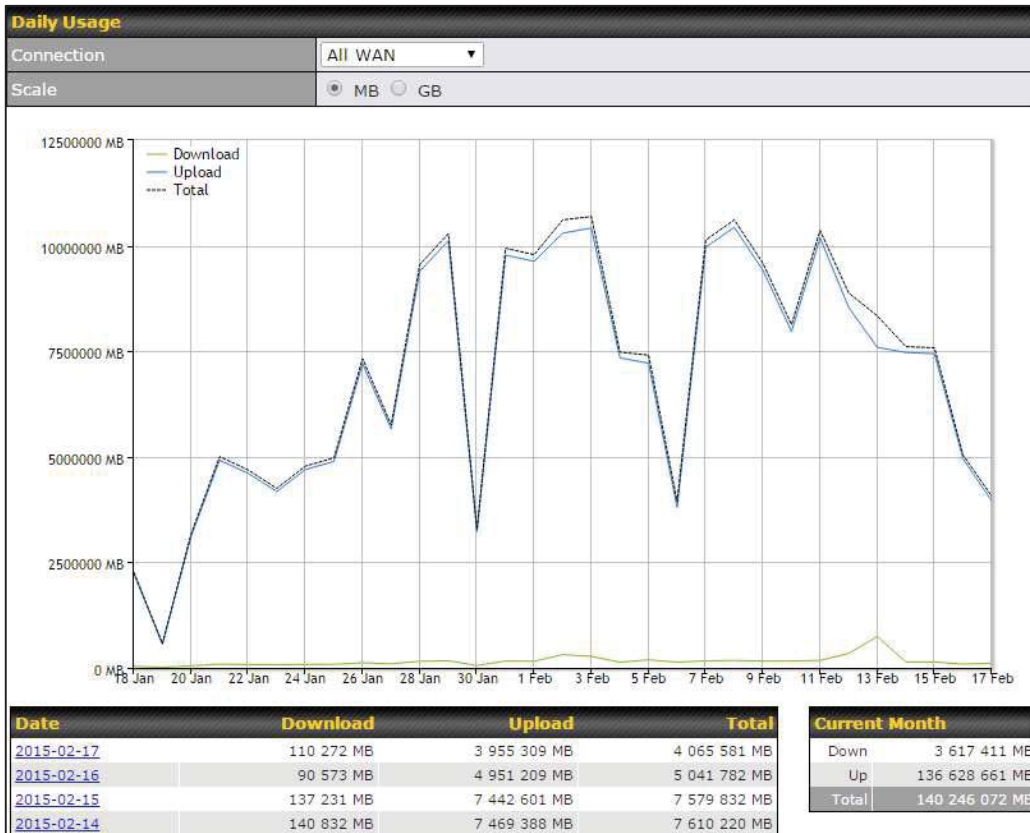

Click on a specific date to receive a breakdown of all client usage for that date.

Client Bandwidth Usage (2015-02-15)

IP Address	Type	Download	Upload	Total
192.168.168.15	LAN Client	7 972.69 MB	1 217 122.81 MB	1 225 095.50 MB
192.168.168.14	LAN Client	7 432.25 MB	1 197 380.53 MB	1 204 812.79 MB
192.168.168.22	LAN Client	5 676.90 MB	617 109.49 MB	622 786.39 MB
192.168.168.21	LAN Client	5 693.38 MB	615 629.07 MB	621 322.46 MB
192.168.168.12	LAN Client	2 156.79 MB	339 779.46 MB	341 936.25 MB
192.168.168.16	LAN Client	2 107.10 MB	333 980.14 MB	336 087.23 MB
192.168.168.18	LAN Client	16.75 MB	9.50 MB	26.25 MB
192.168.167.14	LAN Client	4.74 MB	8.35 MB	13.09 MB
192.168.167.13	LAN Client	4.73 MB	8.35 MB	13.08 MB
192.168.168.19	LAN Client	0.02 MB	0.02 MB	0.03 MB
192.168.168.20	LAN Client	0.00 MB	0.00 MB	0.00 MB
192.168.168.11	LAN Client	0.00 MB	0.00 MB	0.00 MB

13.2.4 Monthly

This page shows the monthly bandwidth usage for each WAN connection. If you have enabled **Bandwidth Monitoring** feature as shown in **Section 13.4**, you can check the usage of each particular connection and view the information by **Billing Cycle** or by **Calendar Month**.

Click the first two rows to view the client bandwidth usage in the last two months. This feature is not available if you have chosen to view the bandwidth of an individual WAN connection. The scale of the graph can be set to display megabytes (**MB**) or gigabytes (**GB**).

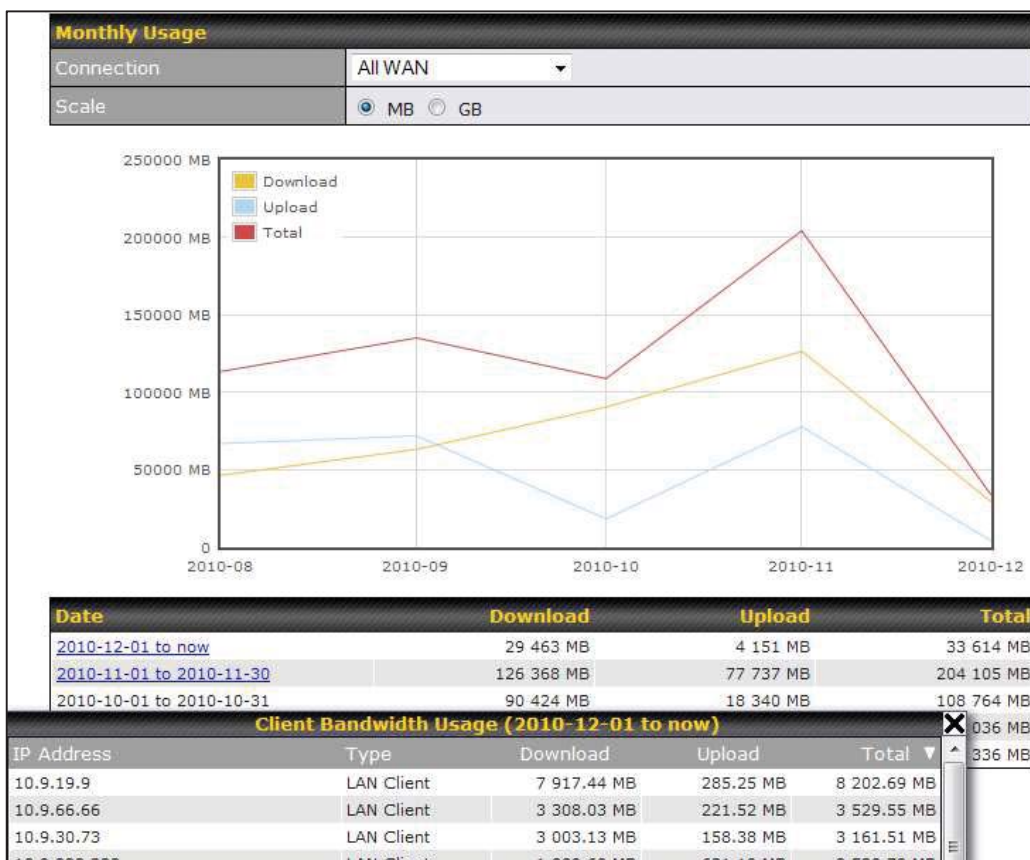

Click on a specific month to receive a breakdown of all client usage for that month.

Appendix A. Restoration of Factory Defaults

To restore the factory default settings on a Peplink Balance unit, perform the following:

For Balance models with a reset button:

1. Locate the reset button on the Peplink Balance unit.
2. With a paper clip, press and keep the reset button pressed for at least 10 seconds, until the unit reboots itself.

For Balance/MediaFast models with an LCD menu:

- Use the buttons on front panel to control the LCD menu to go to **Maintenance>Factory Defaults**, and then choose **Yes** to confirm.

Afterwards, the factory default settings will be restored.

Important Note

All user settings will be lost after restoring the factory default settings. Regular backup of configuration parameters is strongly recommended.

Appendix B. Routing under DHCP, Static IP, and PPPoE

The information in this appendix applies only to situations where the Peplink Balance operates a WAN connection under DHCP, Static IP, or PPPoE.

B.1 Routing Via Network Address Translation (NAT)

When the Peplink Balance is operating under NAT mode, the source IP addresses of outgoing IP packets are translated to the WAN IP address of the Peplink Balance. With NAT, all LAN devices share the same WAN IP address to access the Internet (i.e., the WAN IP address of the Peplink Balance).

Operating the Peplink Balance in NAT mode requires only one WAN (Internet) IP address. In addition, operating in NAT mode also has security advantages because LAN devices are hidden behind the Peplink Balance. They are not directly accessible from the Internet and hence less vulnerable to attacks.

The following figure shows the packet flow in NAT mode:

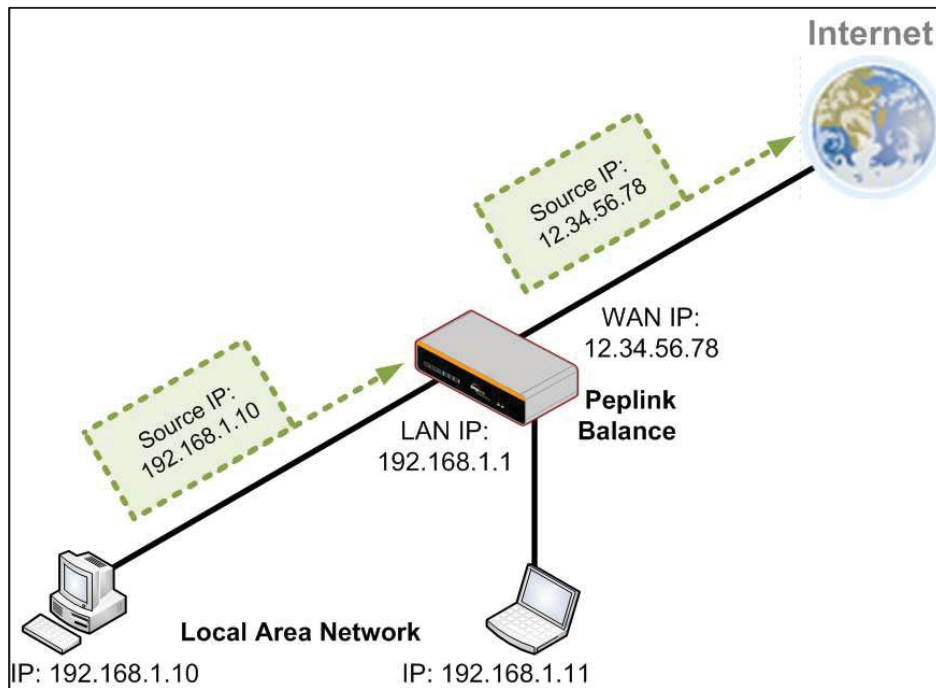

B.2 Routing Via IP Forwarding

When the Peplink Balance is operating under IP forwarding mode, the IP addresses of IP packets are unchanged; the Peplink Balance forwards both inbound and outbound IP packets without changing their IP addresses.

The following figure shows the packet flow in IP forwarding mode:

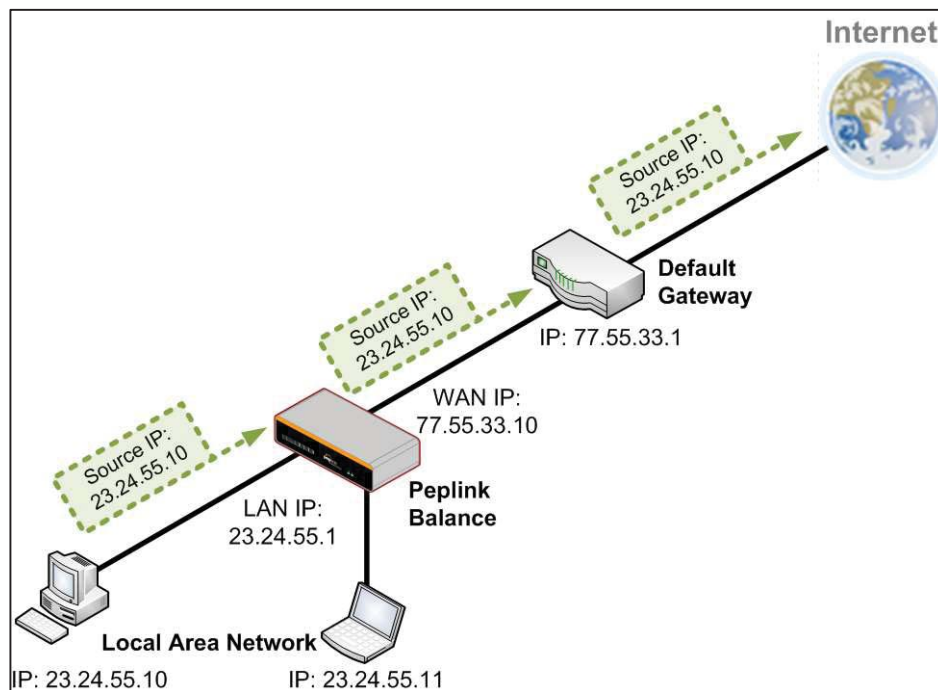

Appendix C. Case Studies

MPLS Alternative

Our SpeedFusion enabled routers can be used to bond multiple low-cost/commodity Internet connections to replace an expensive managed business Internet connection, private leased line, MPLS, and frame relay without sacrificing reliability and availability.

Belows are typical deployment for using our Balance routers to replace expensive MPLS connection with commodity connections, such as ADSL, 3G, and 4G LTE links.

Special features of Balance 580: have high availability capability

Special features of Balance 2500: have high availability capability and capable of connecting to optical fiber based LAN through SFP+ connector

Our WAN-bonding routers which comprise our Balance series and MediaFast series are capable of connecting multiple devices, and end users' networks to the Internet through multiple Internet connections.

Our MediaFast series routers have been helping students at many education institutions to enjoy uninterrupted learning

Option 1: MPLS Supplement

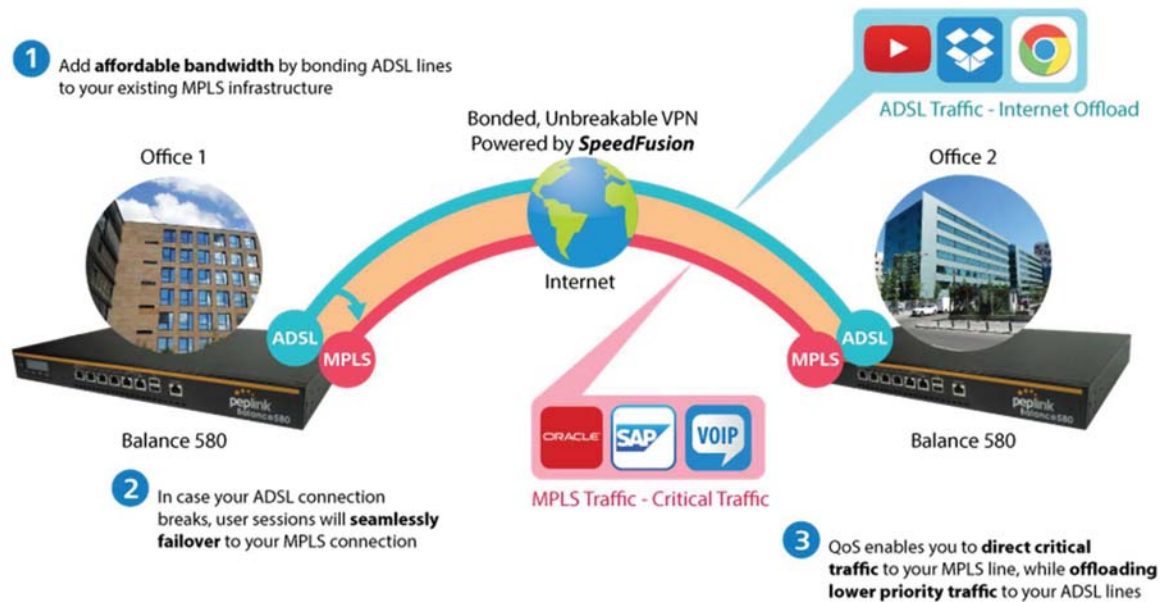

Affordably increase your bandwidth by adding commodity ADSL links to your MPLS connection. SpeedFusion technology bonds all your connections together, enabling session-persistent, user-transparent hot failover. QoS support, bandwidth control, and traffic prioritization gives you total control over your network.

Option 2: MPLS Alternative

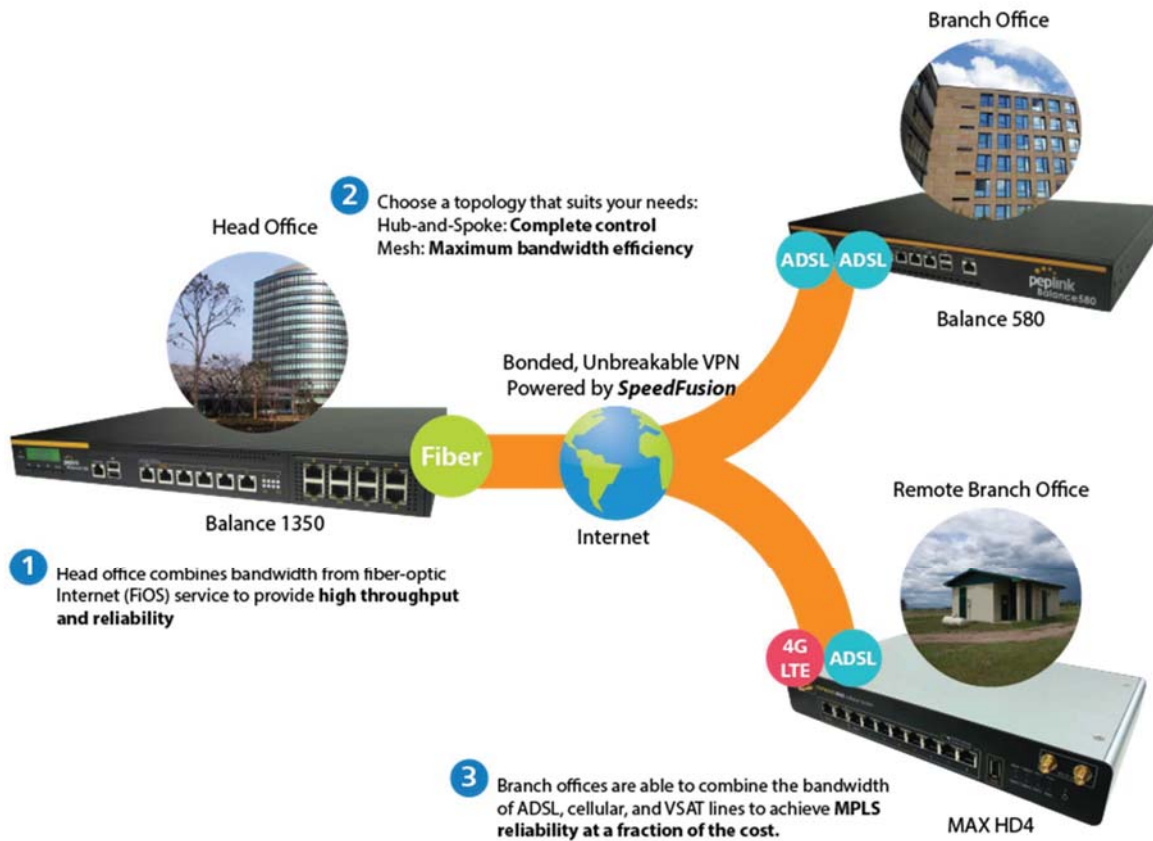

Achieve faster speeds and greater reliability while paying only 20% of MPLS costs by connecting multiple ADSL, 3G, and 4G LTE links. Choose a topology that suits your requirements: a hub-and-spoke topology maximizes control over your network, while a meshed topology can reduce your bandwidth overhead by enabling your devices to form Unbreakable VPN connections directly with each other.

Here is an example of to supplement of existing Multi-Office MPLS network with DSL bonding through SpeedFusion using a Balance 580 at the headquarters and Balance 210/310 at branch offices.

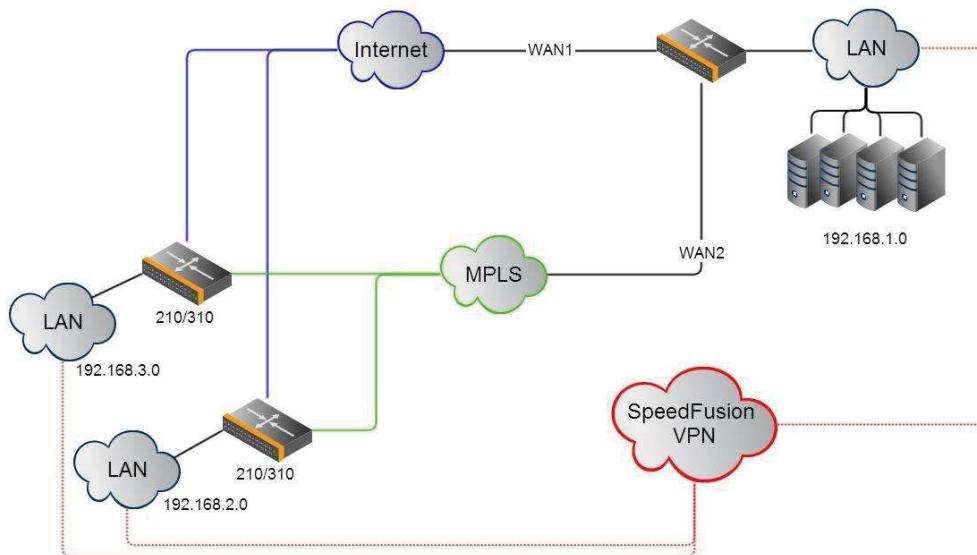

Environment:

- This organization has one head office with and two branch offices, with most of the crucial information stored in a server room at the head office.
- They are connecting the offices together using a managed MPLS Solution. However, the MPLS Network is operating at capacity and upgrading the links is cost prohibitive.
- As the organization grows, it needs a cost-efficient way to to add more bandwidth to its wide area network.
- Internet access at the remote sites is sent via a web proxy at head office for corporate web filtering compliance.

Requirement:

- User sessions need to remain uninterrupted
- More bandwidth is required at the head office location for direct internet access.

Recommended Solution:

- Form a SpeedFusion tunnel between the branch offices and head office to bond the MPLS and additional DSL lines.
- SpeedFusion allows for hot failover, maintaining a persistent session while switching connections.

- The DSLs at head office can be used for direct internet access providing lots of cheap internet bandwidth.
- Head office can use outbound policies to send internet traffic out over the DSLs and only use the MPLS connection for speedfusion, freeing up bandwidth.

Devices Deployed: Balance 210, Balance 310, Balance 580

Harrington Industrial Plastics



Overview

Harrington Plastics, the US's largest industrial plastics distributor, was looking to upgrade its network equipment. Harrington's team came across Peplink and started thinking about MPLS alternatives. By choosing Peplink, they saved a fortune on upgrades and ended up with yearly savings of up to \$100,000.

Requirements

- Zero network outages
- Flexible resilience options
- Cost-effective solution

Solution

- Peplink Balance 1350

- Peplink Balance 380
- Unbreakable VPN

Benefits

- Extreme savings of \$100,000 per year
- 4x the bandwidth
- Seamless hardware failover
- Highly available network due to WAN diversity
- Highly cost-effective compared to competing solutions
- Easy resilience achieved by adding 4G USB modems

Time For An Upgrade

Harrington Industrial Plastics decided it was time to upgrade its network equipment. Its existing solution used redundant MPLS for site-to-site traffic and broadband connections for Internet access. Harrington is the US's largest distributor of industrial plastics piping, serving all industries with corrosive and high-purity applications. It requires peak performance at all times in order to serve its large customer base and 43 busy branches.

Quick Deployment and Unbreakable Connectivity

In evaluating an upgrade to its network infrastructure, it was only natural that Harrington settled on the best in the industry — Peplink. Peplink partner Frontier Computer Corporation was chosen to help design and deploy the solution. Since Peplink gear is so easy to configure and install, Harrington was able to design, prototype and roll out the entire solution to the corporate headquarters and all 43 branches within just one year.

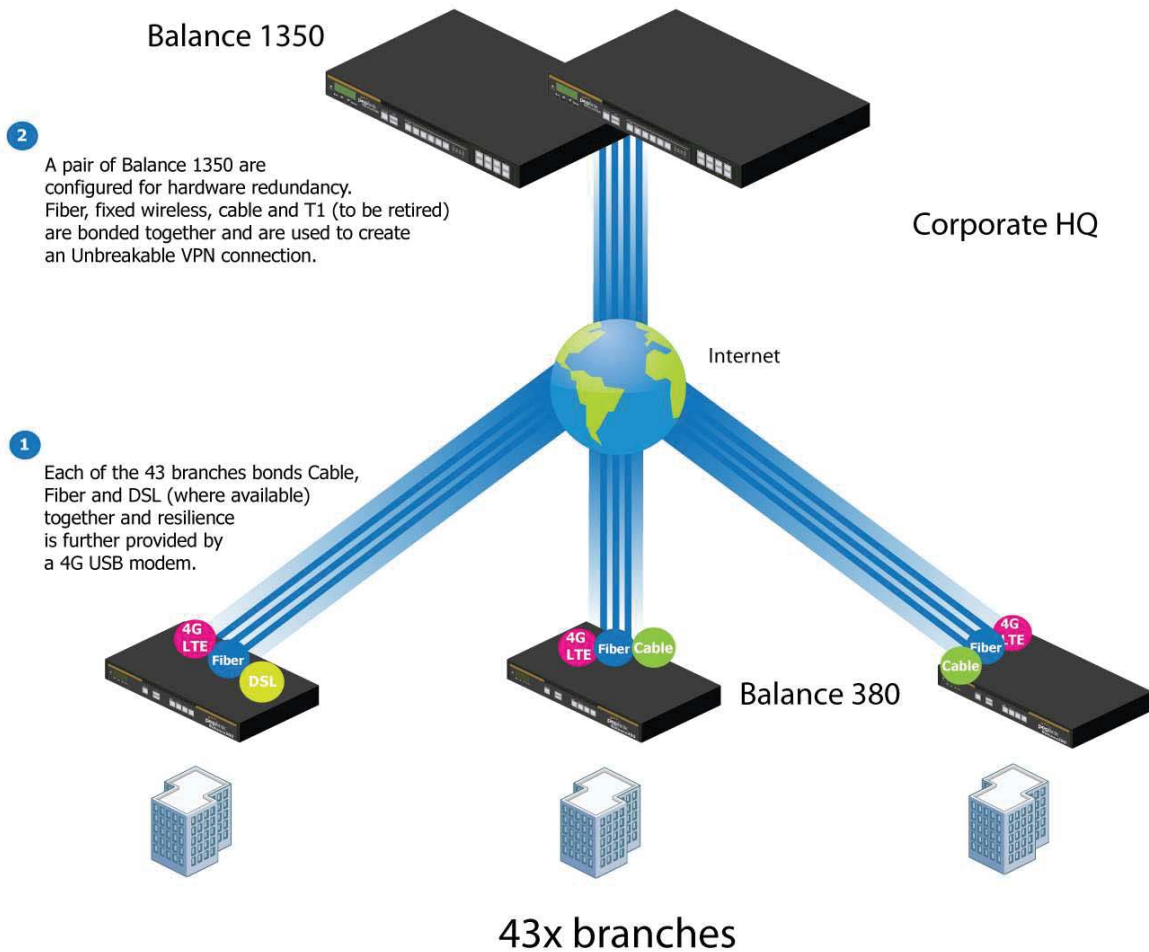

The corporate office houses a pair of redundant Balance 1350s for hardware resilience. Served by 4 separate links from multiple service providers, the network’s chance of an outage is practically zero. All 43 branches are now equipped with a fleet of Balance 380s, bonding a combination of DSL, cable and fiber-optic links together with an additional 4G USB modem for added resilience. These work together to create an Unbreakable VPN connection to the Balance 1350s at the corporate office, connecting the final dot.

Dependable, Resilient Networking that’s also Very Budget-friendly

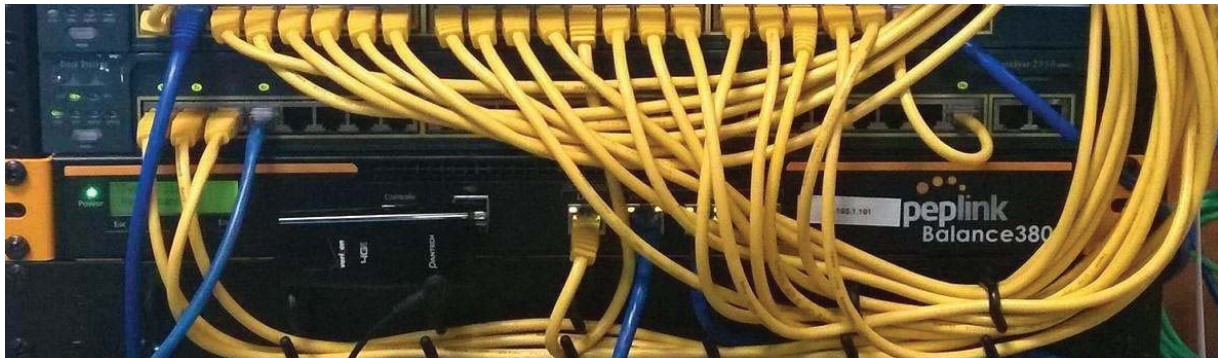

Harrington Industrial Plastics couldn't be happier. They now benefit from an extremely reliable and cost-effective network. Supplying additional resilience is as easy as plugging in a 4G USB modem. Where the MPLS 768kb deployed previously had cost them \$192000 a year for all 40 sites, their new solution is now only costing them \$92000. Their total bandwidth has been bumped from 36 Mbps to 138 Mbps.

PLUSS

Peplink + Citrix + VoIP Adds Up to Fast, Cost-Effective WAN for Pluss

Adding to Life
pluss

400
USERS

VoIP 290
EndPoints

30+
SITES

"It saves us money, is easy to manage and grows with us effortlessly."
Steve Taylor - Pluss

A Peplink customer since 2006, Pluss is a social enterprise that each year makes gainful employment a reality for more than 5000 disabled and disadvantaged UK citizens. With 37 locations and 300+ active users, Pluss makes heavy use of its WAN infrastructure, which until recently was built on managed MPLS lines.

Hoping to cut expenses and, if possible, boost performance at the same time, Steve Taylor, IT Manager at Pluss, set out to find a solution that would allow Pluss to replace costly MPLS service with a commodity alternative, such as DSL or EFM.

Steve found the solution Pluss needed in Peplink products, especially the Balance series of high-performance enterprise routers and SpeedFusion bonding technology. Pluss now powers its entire WAN infrastructure with simple-to-install, highly reliable, and cost-effective Peplink gear, which allows it to aggregate DSL and other commodity connections and replace expensive leased lines.

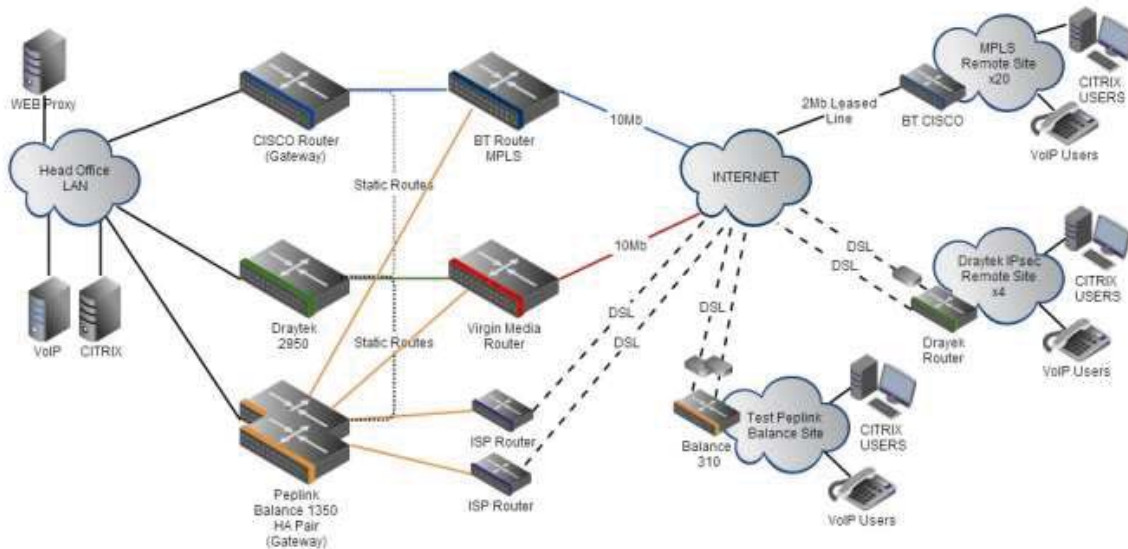

Colégio Next - Enabling eLearning



Colégio Next, a recognized Apple Distinguished School - deploys over 500 iPads to its 600 students as a teaching and learning tool.

Despite being equipped with iPads, teachers and students alike were not making use of them. The reason for this was because of the slow network access speeds. Apps would not download and course contents were inaccessible. Often, having more than a couple students connected to the same Wi-Fi access point was enough to bring it to its knees.

Colégio Next needed a unique solution, so they contacted Peplink.

Requirements

- Solve network congestion problem caused by 600 students over rural Internet connections
- Wi-Fi that can handle 50+ users per classroom
- An affordable network infrastructure that can provide simultaneous access to media-rich educational content

Solution

- Peplink MediaFast
- Multi-WAN Content-caching router, tailor-made for Education networking.
- AP One 300M
- Enterprise grade AP, 5GHz Wi-Fi, up to 60 concurrent users.

Benefits

- Instant, simultaneous access to media-rich educational content for 500+ iPads
- Wi-Fi connection stability for 50+ users per classroom, not achievable by other tested equipment
- Teachers, students and guests can be assigned access priority to available bandwidth, further preventing congestion
- iOS updates (often 2GB size) no longer congest the network as they are downloaded only once, cached on the MediaFast and then distributed to all iOS devices
- AP Controller makes MAC Address Filtering easy. Students are assigned to designated APs by their devices' MAC Address in order to prevent saturating any single AP.
- Flawless iPad AirPlay mirroring at all times
- iPads are used all day, reaching their full potential with a fast and stable network all the time

- Students are far more engaged and teachers rely on their iPads all day

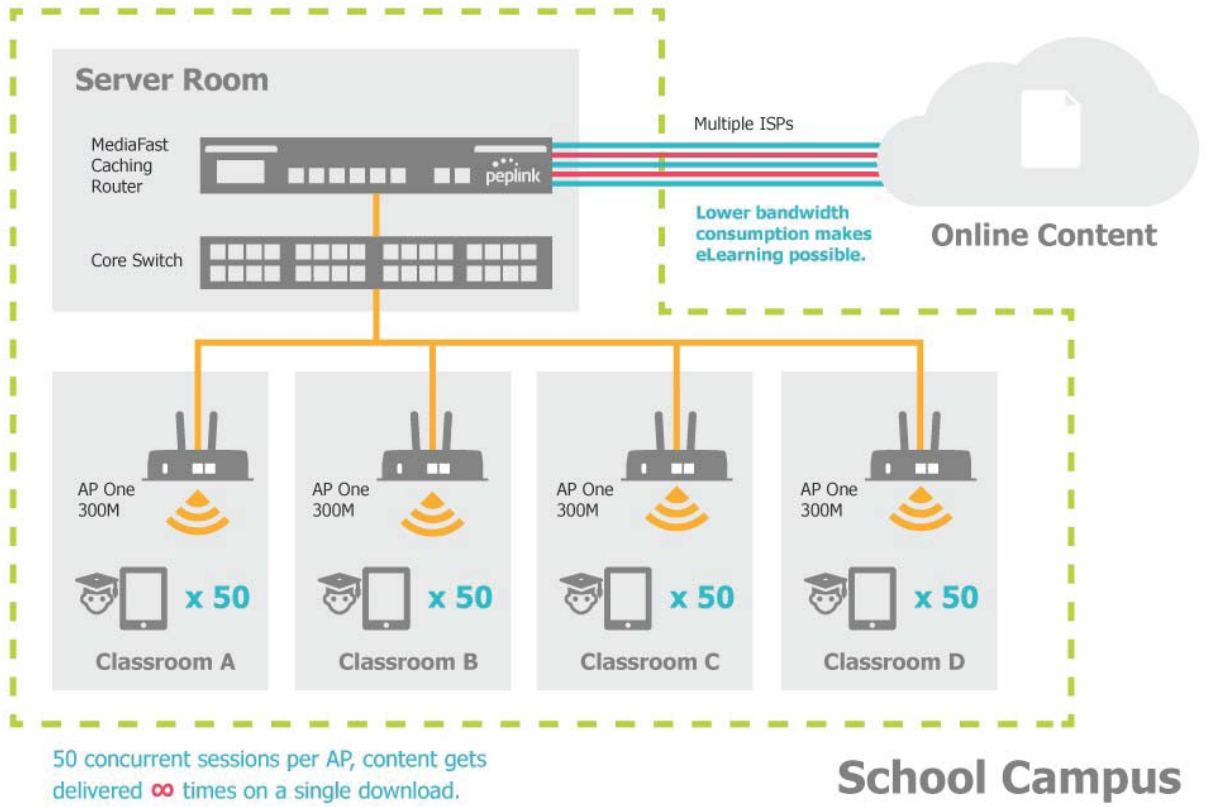

Performance Optimization

Scenario

In this scenario, email and web browsing are the two main Internet services used by LAN users.

The mail server is external to the network. The connections are ADSL (WAN1, with slow uplink and fast downlink) and Metro Ethernet (WAN2, symmetric).

Solution

For optimal performance with this configuration, individually set the WAN load balance according to the characteristics of each service.

- Web browsing mainly downloads data; sending e-mails mainly consumes upload bandwidth.
- Both connections offer good download speeds; WAN2 offers good upload speeds.
- Define WAN1 and WAN2's inbound and outbound bandwidths to be 3M/512k and 4M/4M, respectively. This will ensure that outbound traffic is more likely to be routed through WAN2.
- For HTTP, set the weight to 3:4.
- For SMTP, set the weight to 1:8, such that users will have a greater chance to be routed via WAN2 when sending e-mail.

Maintaining the Same IP Address Throughout a Session

Scenario

Some IP address-sensitive websites (for example, Internet banking) use both client IP address and cookie matching for session identification. Since load balancing uses different IP addresses, the session is dropped when a mismatched IP is detected, resulting in frequent interruptions while visiting such sites.

Solution

Make use of the persistence functionality of the Peplink Balance. With persistence configured and the **By Destination** option selected, the Peplink Balance will use a consistent WAN connection for source-destination pairs of IP addresses, preventing sessions from being dropped.

With persistence configured and the option **By Source** is selected, the Peplink Balance uses a consistent WAN connection for same-source IP addresses. This option offers

higher application compatibility but may inhibit the load balancing function unless there are many clients using the Internet.

Settings

Set persistence in at **Advanced>Outbound Policy**.

Click **Add Rule**, select **HTTP** (TCP port 80) for web service, and select **Persistence**. Click **Save** and then **Apply Changes**, located at the top right corner, to complete the process.

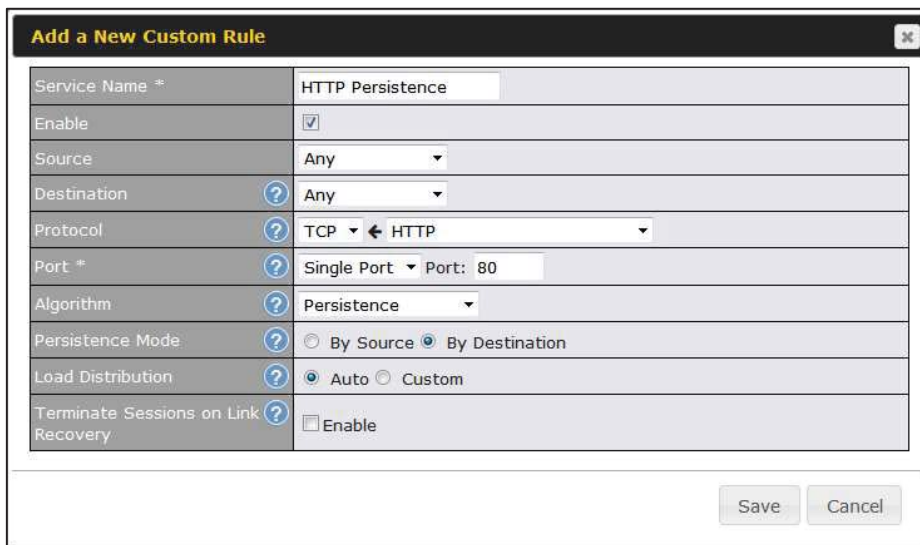

Add a New Custom Rule	
Service Name *	HTTP Persistence
Enable	<input checked="" type="checkbox"/>
Source	Any
Destination	Any
Protocol	TCP ← HTTP
Port *	Single Port Port: 80
Algorithm	Persistence
Persistence Mode	<input type="radio"/> By Source <input checked="" type="radio"/> By Destination
Load Distribution	<input checked="" type="radio"/> Auto <input type="radio"/> Custom
Terminate Sessions on Link Recovery	<input type="checkbox"/> Enable

Save Cancel

Tip

A network administrator can use the traceroute utility to manually analyze the connection path of a particular WAN connection.

Bypassing the Firewall to Access Hosts on LAN

Scenario

There are times when remote access to computers on the LAN is desirable; for example, when hosting web sites, online businesses, FTP download and upload areas, etc. In such cases, it may be appropriate to create an inbound NAT mapping for the network to allow some hosts on the LAN to be accessible from outside of the firewall.

Solution

The web admin interface can be used to add an inbound NAT mapping to a host and to

bind the host to the WAN connection(s) of your choice. To begin, navigate to **Network>NAT Mappings**.

In this example, the host with an IP address of 192.168.1.102 is bound to 10.90.0.75 of WAN1:

LAN Client(s)	IP Address ▾
Address	192.168.1.102
Inbound Mappings	Connection / Inbound IP Address(es)
	<input checked="" type="checkbox"/> WAN 1 10.90.0.75 (Interface IP)
	<input type="checkbox"/> WAN 2
	<input type="checkbox"/> WAN 3
	<input type="checkbox"/> WAN 4
	<input type="checkbox"/> WAN 5
	<input type="checkbox"/> WAN 6
	<input type="checkbox"/> WAN 7
<input type="checkbox"/> Mobile Internet	
Outbound Mappings	Connection / Outbound IP Address
	WAN 1 10.90.0.75 (Interface IP) ▾
	WAN 2 10.90.0.76 (Interface IP) ▾
	WAN 3 Interface IP ▾
	WAN 4 Interface IP ▾
	WAN 5 Interface IP ▾
	WAN 6 Interface IP ▾
	WAN 7 Interface IP ▾
Mobile Internet Interface IP ▾	

Click **Save** and then **Apply Changes**, located at the top right corner, to complete the process.

Inbound Access Restriction

Scenario

A firewall is required in order to protect the network from potential hacker attacks and other Internet security threats.

Solution

Firewall functionality is built into the Peplink Balance. By default, inbound access is

unrestricted. Enabling a basic level of protection involves setting up firewall rules. For example, in order to protect your private network from external access, you can set up a firewall rule between the Internet and your private network. To do so, navigate to **Advanced>Firewall>Access Rules**. Then click the **Add Rule** button in the **Inbound Firewall Rules** table and change the settings according to the following screenshot:

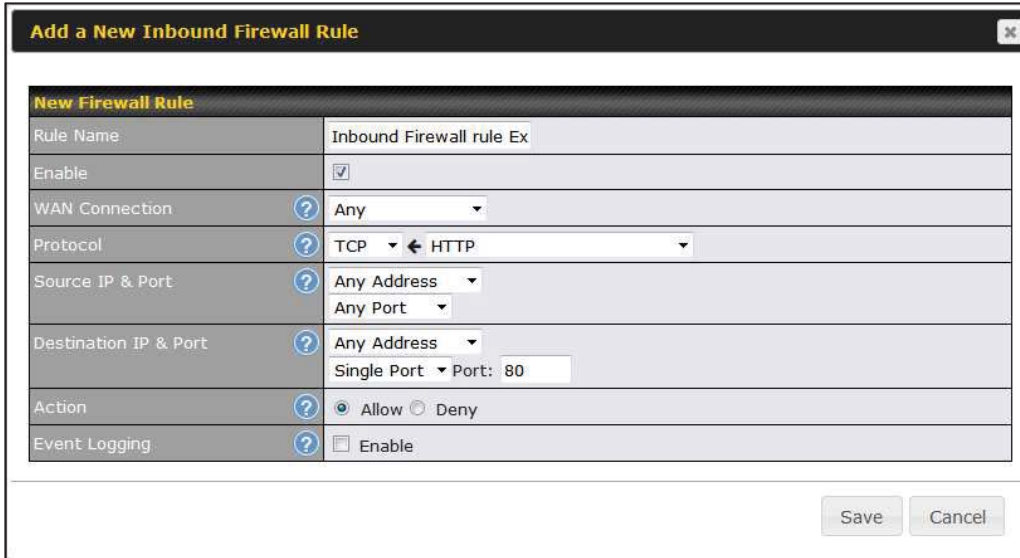

New Firewall Rule	
Rule Name	Inbound Firewall rule Ex
Enable	<input checked="" type="checkbox"/>
WAN Connection	Any
Protocol	TCP HTTP
Source IP & Port	Any Address Any Port
Destination IP & Port	Any Address Single Port Port: 80
Action	<input checked="" type="radio"/> Allow <input type="radio"/> Deny
Event Logging	<input type="checkbox"/> Enable

After the fields have been entered as in the screenshot, click **Save** to add the rule. Afterwards, change the default inbound rule to **Deny** by clicking the **default** rule in the **Inbound Firewall Rules** table. Click **Apply Changes** on the top right corner to complete the process.

Outbound Access Restriction

Scenario

For security reasons, it may be appropriate to restrict outbound access. For example, you may want to prevent LAN users from using ftp to transfer files to and from the Internet. This can easily be achieved by setting up an outbound firewall rule with the Peplink Balance.

Solution

To setup a firewall between Internet and private network for outbound access, navigate to **Advanced>Firewall>Access Rules**. Click the **Add Rule** button in the **Outbound Firewall Rules** table, and then adjust settings according the screenshot:

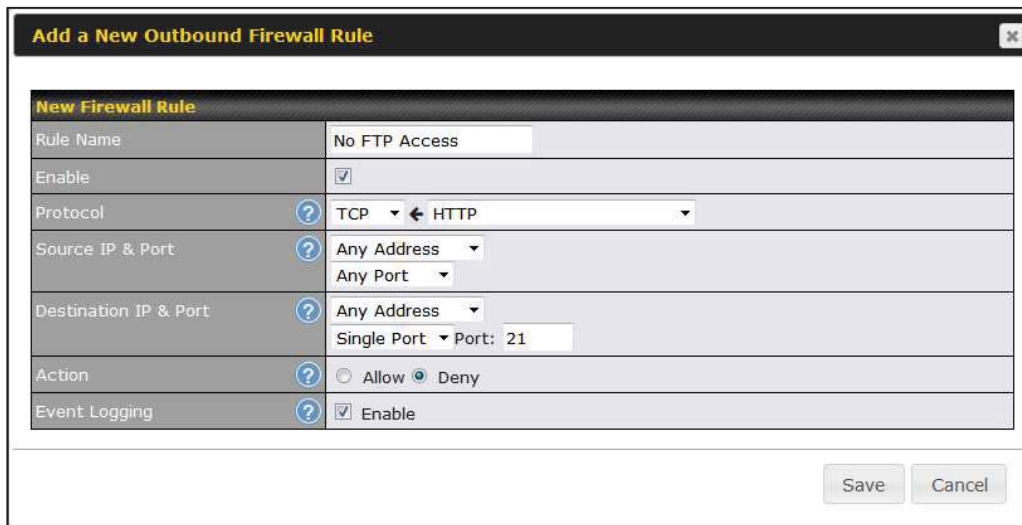

New Firewall Rule	
Rule Name	No FTP Access
Enable	<input checked="" type="checkbox"/>
Protocol	TCP ← HTTP
Source IP & Port	Any Address Any Port
Destination IP & Port	Any Address Single Port Port: 21
Action	<input type="radio"/> Allow <input checked="" type="radio"/> Deny
Event Logging	<input checked="" type="checkbox"/> Enable

Save Cancel

After the fields have been entered as in the screenshot, click **Save** to add the rule. Click **Apply Changes** on the top right corner to complete the process.

Appendix D. Troubleshooting

Problem 1

Outbound load is only distributed over one WAN connection.

Solution

Outbound load balancing can only be distribute traffic evenly between available WAN connections if many outbound connections are made. If there is only one user on the LAN and only one download session is made from his/her browser, the WAN connections cannot be fully utilized.

For a single user, download management applications are recommended. The applications can split a file into pieces and download the pieces simultaneously. Examples include: DownThemAll (Firefox Extension), iGetter (Mac), etc.

If the outbound traffic is going across the SpeedFusion™ tunnel, (i.e., transferring a file to a VPN peer) the bandwidth of all WAN connections will be bonded. In this case, all bandwidth will be utilized and a file will be transferred across all available WAN connections.

For additional details, please refer to this FAQ:

<http://www.peplink.com/knowledgebase/maximizing-your-wan-connections-without-speedfusion/>

Problem 2

I am using a download manager program (e.g., Download Accelerator Plus, DownThemAll, etc.). Why is the download speed still only that of a single link?

Solution

First, check whether all WAN connections are up. Second, ensure your download manager application has split the file into 3 parts or more. It is also possible that all of 2 or even 3 download sessions were being distributed to the same link by chance.

Problem 3

I am using some websites to look up my public IP address, e.g., www.whatismyip.com. When I press the browser's Refresh button, the server almost always returns the same address. Isn't the IP address supposed to be changing for every refresh?

Solution

The web server has enabled the **Keep Alive** function, which ensures that you use the same TCP session to query the server. Try to test with a website that does not enable

Keep Alive.

For example, try <http://private.dnsstuff.com/tools/aboutyou.ch>. (This third-party web site is provided only for reference. Peplink has no association with the site and does not guarantee the site's validity or availability.)

Problem 4

What can I do if I suspect a problem on my LAN connection?

Solution

You can test the LAN connection using ping. For example, if you are using DOS/Windows, at the command prompt, type *ping 192.168.1.1*. This pings the Peplink Balance device (provided that Peplink Balance's IP is 192.168.1.1) to test whether the connection to the Peplink Balance is OK.

Problem 5

What can I do if I suspect a problem on my Internet/WAN connection?

Solution

You can test the WAN connection using ping, as in the solution to Problem 4. As we want to isolate the problems from the LAN, ping will be performed from the Peplink Balance. By using **Ping/Traceroute** under the **Status** tab of the Peplink Balance, you may be able to find the source of the problem.

Problem 6

When I upload files to a server via FTP, the transfer stalls after a few kilobytes of data are sent. What should I do?

Solution

The maximum transmission unit (MTU) or MSS setting may need to be adjusted. By default, the MTU is set at 1440. Choose **Auto** for all of your WAN connections. If that does not solve the problem, you can try the MTU 1492 if a connection is DSL. If the problem still persists, change the size to progressively smaller values until your problem is resolved (e.g., 1462, 1440, 1420, 1400, etc).

Additional troubleshooting resources:

Peplink Community Forums: <https://forum.peplink.com/>

Appendix E. Declaration

CAUTION:

RISK OF EXPLOSION IF BATTERY IS REPLACED BY AN INCORRECT TYPE.
DISPOSE OF USED BATTERIES ACCORDING TO THE INSTRUCTIONS

Federal Communication Commission Interference Statement

This equipment has been tested and found to comply with the limits for a Class A digital device, pursuant to part 15 of the FCC Rules. These limits are designed to provide reasonable protection against harmful interference when the equipment is operated in a commercial environment. This equipment generates, uses, and can radiate radio frequency energy and, if not installed and used in accordance with the instruction manual, may cause harmful interference to radio communications. Operation of this equipment in a residential area is likely to cause harmful interference in which case the user will be required to correct the interference at his own expense.

FCC Caution: Any changes or modifications not expressly approved by the party responsible for compliance could void the user's authority to operate this equipment.

This transmitter must not be co-located or operating in conjunction with any other antenna or transmitter.

Radiation Exposure Statement:

This equipment complies with FCC radiation exposure limits set forth for an uncontrolled environment. This equipment should be installed and operated with a minimum distance of 20cm between the radiator and your body.

Note: The country code selection is for non-US models only and is not available to all US models. Per FCC regulation, all WiFi products marketed in US must fixed to US operation channels only

EU Declaration of Conformity

Name of manufacturer: PISMO LABS TECHNOLOGY LIMITED

Address of the manufacturer: FLAT/RM A5 5/F HK SPINNERS IND BLDG PHASE 6, 481
CASTLE PEAK ROAD CHEUNG SHA WAN, Kowloon, Hong Kong

We affirm the electrical equipment manufactured by us fulfils the requirements of the
Radio Equipment Directive 2014/53/EU.

Description of the appliance: PEPWAVE / PEPLINK Wireless Product

Model name of the appliance: Peplink Balance 30 LTE / BPL-031-LTE-E-T / Balance 30 LTE
/ Pismo811AC / B30 LTE / Peplink Balance 30

Trademark: PEPWAVE / PEPLINK

The construction of the appliance is in accordance with the following standards:

EN 301 908-1 V11.1.1
Draft EN 301 489-1 V2.2.0
Draft EN 301 489-52 V1.1.0
EN 55032: 2015 + AC:2016
EN 61000-3-2: 2014
EN 61000-3-3: 2013
EN 55035: 2017
EN 62311: 2008
EN 62368-1:2014/AC:2015

Hong Kong, May 7, 2019

A.C.H.



Antony Chong
 Director of Hardware Engineering
 Peplink International Limited



cs [Czech]	<i>[Jméno výrobce]</i> tímto prohlašuje, že tento <i>[typ zařízení]</i> je ve shodě se základními požadavky a dalšími příslušnými ustanoveními směrnice 1999/5/ES.
da [Danish]	Undertegnede <i>[fabrikantens navn]</i> erklærer herved, at følgende udstyr <i>[udstyrets typebetegnelse]</i> overholder de væsentlige krav og øvrige relevante krav i direktiv 1999/5/EF.
de [German]	Hiermit erkläre <i>[Name des Herstellers]</i> , dass sich das Gerät <i>[Gerätetyp]</i> in Übereinstimmung mit den grundlegenden Anforderungen und den übrigen einschlägigen Bestimmungen der Richtlinie 1999/5/EG befindet.
et [Estonian]	Käesolevaga kinnitab <i>[tootja nimi = name of manufacturer]</i> seadme <i>[seadme tüüp = type of equipment]</i> vastavust direktiivi 1999/5/EÜ põhinõuetele ja nimetatud direktiivist tulenevatele teistele asjakohastele sätetele.
en [English]	Hereby, <i>[name of manufacturer]</i> , declares that this <i>[type of equipment]</i> is in compliance with the essential requirements and other relevant provisions of Directive 1999/5/EC.
es [Spanish]	Por medio de la presente <i>[nombre del fabricante]</i> declara que el <i>[clase de equipo]</i> cumple con los requisitos esenciales y cualesquiera otras disposiciones aplicables o exigibles de la Directiva 1999/5/CE.
el [Greek]	ΜΕ ΤΗΝ ΠΑΡΟΥΣΑ <i>[name of manufacturer]</i> ΔΗΛΩΝΕΙ ΟΤΙ <i>[type of equipment]</i> ΣΥΜΜΟΡΦΩΝΕΤΑΙ ΠΡΟΣ ΤΙΣ ΟΥΣΙΩΔΕΙΣ ΑΠΑΙΤΗΣΕΙΣ ΚΑΙ ΤΙΣ ΛΟΙΠΕΣ ΣΧΕΤΙΚΕΣ ΔΙΑΤΑΞΕΙΣ ΤΗΣ ΟΔΗΓΙΑΣ 1999/5/ΕΚ.
fr [French]	Par la présente <i>[nom du fabricant]</i> déclare que l'appareil <i>[type d'appareil]</i> est conforme aux exigences essentielles et aux autres dispositions pertinentes de la directive 1999/5/CE.
it [Italian]	Con la presente <i>[nome del costruttore]</i> dichiara che questo <i>[tipo di apparecchio]</i> è conforme ai requisiti essenziali ed alle altre disposizioni pertinenti stabilite dalla direttiva 1999/5/CE.
lv [Latvian]	Ar šo <i>[name of manufacturer / izgatavotāja nosaukums]</i> deklarē, ka <i>[type of equipment /</i>

[Latvian]	<i>iekārtas tips</i>] atbilst Direktīvas 1999/5/EK būtiskajām prasībām un citiem ar to saistītajiem noteikumiem.
[lt]Lietuvių [Lithuanian]	Šiuo [<i>manufacturer name</i>] deklaruoja, kad šis [<i>equipment type</i>] atitinka esminius reikalavimus ir kitas 1999/5/EB Direktyvos nuostatas.
[nl]Nederlands [Dutch]	Hierbij verklaart [<i>naam van de fabrikant</i>] dat het toestel [<i>type van toestel</i>] in overeenstemming is met de essentiële eisen en de andere relevante bepalingen van richtlijn 1999/5/EG.
[mt]Malti [Maltese]	Hawnhekk, [<i>isem tal-manifattur</i>], jiddikjara li dan [<i>il-mudel tal-prodott</i>] jikkonforma mal-ħtiġijiet essenzjali u ma provvedimenti oħrajn relevanti li hemm fid-Dirrettiva 1999/5/EC.
[hu]Magyar [Hungarian]	Alulírott, [<i>gyártó neve</i>] nyilatkozom, hogy a [<i>... típus</i>]megfelel a vonatkozó alapvető követelményeknek és az 1999/5/EC irányelv egyéb előírásainak.
[pl]Polski [Polish]	Niniejszym [<i>nazwa producenta</i>] oświadcza, że [<i>nazwa wyrobu</i>] jest zgodny z zasadniczymi wymogami oraz pozostałymi stosownymi postanowieniami Dyrektywy 1999/5/EC.
[pt]Português [Portuguese]	[<i>Nome do fabricante</i>] declara que este [<i>tipo de equipamento</i>] está conforme com os requisitos essenciais e outras disposições da Directiva 1999/5/CE.
[sl]Slovensko [Slovenian]	[<i>Ime proizvajalca</i>] izjavlja, da je ta [<i>tip opreme</i>] v skladu z bistvenimi zahtevami in ostalimi relevantnimi določili direktive 1999/5/ES.
[sk]Slovensky [Slovak]	[<i>Meno výrobcu</i>] týmto vyhlasuje, že [<i>typ zariadenia</i>]spĺňa základné požiadavky a všetky príslušné ustanovenia Smernice 1999/5/ES.
[fi]Suomi [Finnish]	[<i>Valmistaja = manufacturer</i>] vakuuttaa täten että [<i>type of equipment = laitteen tyyppimerkintä</i>] tyyppinen laite on direktiivin 1999/5/EY oleellisten vaatimusten ja sitä koskevien direktiivin muiden ehtojen mukainen.
[sv]Svenska [Swedish]	Härmed intygar [<i>företag</i>] att denna [<i>utrustningstyp</i>] står i överensstämmelse med de väsentliga egenskapskrav och övriga relevanta bestämmelser som framgår av direktiv 1999/5/EG.