

**ELECTROMAGNETIC EMISSIONS COMPLIANCE REPORT
INTENTIONAL RADIATOR CERTIFICATION TO
FCC PART 15 SUBPART C REQUIREMENT**

OF

Wireless Keyboard

MODEL No.: RF-8105

BRAND NAME: Unitek

FCC ID: T5YRFKB8105

REPORT NO: E0604031F

ISSUE DATE: April 14, 2006

Prepared for

**Unitek Electronic Co., Ltd.
Huimingsheng Industrial Zone, Fuyong Town, Baoan, Shenzhen,
Guangdong, China**

Prepared by

SHENZHEN EMTEK CO., LTD

**Bldg 69, Majialong Industry Zone, Nanshan District,
Shenzhen, Guangdong, China
TEL: 86-755-26954280
FAX: 86-755-26954282**

VERIFICATION OF COMPLIANCE

Applicant:	Unitek Electronic Co., Ltd. Huimingsheng Industrial Zone, Fuyong Town, Baoan, Shenzhen, Guangdong, China
Product Description:	Wireless Keyboard
Brand Name:	Unitek
Model Number:	RF-8105
Serial Number:	N/A
File Number:	E0604031F
Date of Test:	April 07, 2006 to April 14, 2006

We hereby certify that:

The above equipment was tested by SHENZHEN EMTEK CO., LTD. The test data, data evaluation, test procedures, and equipment configurations shown in this report were made in accordance with the procedures given in ANSI C63.4 (2003) and the energy emitted by the sample EUT tested as described in this report is in compliance with conducted and radiated emission limits of FCC Rules Part 15.227.

The test results of this report relate only to the tested sample identified in this report.

Approved By

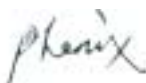

Phenix / Q.A. Manager
SHENZHEN EMTEK CO., LTD.

Reviewed By



David Lee/ Engineer
SHENZHEN EMTEK CO., LTD.

Table of Contents

1. GENERAL INFORMATION.....4

1.1 PRODUCT DESCRIPTION..... 4

1.2 RELATED SUBMITTAL(S) / GRANT (S)..... 4

1.3 TEST METHODOLOGY..... 4

1.4 SPECIAL ACCESSORIES..... 4

1.5 EQUIPMENT MODIFICATIONS..... 4

1.6 TEST FACILITY..... 5

2. SYSTEM TEST CONFIGURATION..... 6

2.1 EUT CONFIGURATION..... 6

2.2 EUT EXERCISE..... 6

2.3 TEST PROCEDURE..... 6

2.4 LIMITATION..... 6

2.5 CONFIGURATION OF TESTED SYSTEM..... 8

3. SUMMARY OF TEST RESULTS..... 10

4. DESCRIPTION OF TEST MODES..... 10

5. CONDUCTED EMISSIONS TEST (NOT APPLICABLE IN THIS REPORT)..... 11

5.1 MEASUREMENT PROCEDURE:..... 11

5.2 TEST SET-UP (BLOCK DIAGRAM OF CONFIGURATION)..... 11

5.3 MEASUREMENT EQUIPMENT USED:..... 11

5.4 MEASUREMENT RESULT:..... 11

5.5 CONDUCTED MEASUREMENT PHOTOS:..... 11

6. RADIATED EMISSION TEST..... 12

6.1 MEASUREMENT PROCEDURE..... 12

6.2 TEST SET-UP (BLOCK DIAGRAM OF CONFIGURATION)..... 13

6.3 MEASUREMENT EQUIPMENT USED:..... 14

6.4 MEASUREMENT RESULT..... 14

7. OCCUPIED BANDWIDTH..... 16

7.1 MEASUREMENT PROCEDURE..... 16

7.2 TEST SET-UP (BLOCK DIAGRAM OF CONFIGURATION)..... 16

7.3 MEASUREMENT EQUIPMENT USED:..... 16

7.4 MEASUREMENT RESULTS:..... 16

APPENDIX 1

PHOTOGRAPHS OF SET UP..... 18

APPENDIX 2

PHOTOGRAPHS OF EUT..... 20

1. GENERAL INFORMATION

1.1 Product Description

The Unitek Electronic Co., Ltd. Model: RF-8105 (referred to as the EUT in this report) The EUT is an short range, lower power, wireless keyboard designed as an " Input Device. It is designed by way of utilizing the FSK modulation achieves the system operating.

A major technical descriptions of EUT is described as following:

- A). Operation Frequency: 27.095 MHz, one channel.
- B). Modulation: Frequency Shifting Key (FSK) Modulation
- C). Antenna Designation: Non-User Replaceable (Fixed)
- D). Power Supply: 3 Vdc by AA *2 battery.

1.2 Related Submittal(s) / Grant (s)

This submittal(s) (test report) is intended for FCC ID: T5YRFKB8105 filing to comply with Section 15.227 of the FCC Part 15, Subpart C Rules. The composite system (receiver) is compliance with Subpart B is authorized under a DoC procedure.

1.3 Test Methodology

Both conducted and radiated testing were performed according to the procedures in ANSI C63.4 (2003). Radiated testing was performed at an antenna to EUT distance 3 meters.

1.4 Special Accessories

Not available for this EUT intended for grant.

1.5 Equipment Modifications

Not available for this EUT intended for grant.

1.6 Test Facility

Site Description
EMC Lab.

: Accredited by CNAL, 2005.11.02
The certificate is valid until 2010.11
The Laboratory has been assessed and proved to be in compliance with
CNAL/AC01:2003(identical to ISO/IEC17025:1999)
The Certificate Registration Number is L2291

Accredited by TUV Rheinland Guangzhou, 2005.1
The certificate is valid until 2008.2
The Laboratory has been assessed according to the requirements ISO/IEC
17025:1999

Accredited by FCC, July 07, 2005
The Certificate Registration Number is 709623.

Accredited by Industry Canada, August 30, 2005
The Certificate Registration Number is 46405-4480

Name of Firm
Site Location

: SHENZHEN EMTEK CO., LTD
: Bldg 69, Majialong Industry Zone,
Nanshan District, Shenzhen, Guangdong, China

2. System Test Configuration

2.1 EUT Configuration

The EUT configuration for testing is installed on RF field strength measurement to meet the Commissions requirement and operating in a manner which intends to maximize its emission characteristics in a continuous normal application.

2.2 EUT Exercise

The Transmitter was operated in the normal operating mode. the Tx frequency was fixed which was for the purpose of the measurements.

2.3 Test Procedure

2.3.1 Conducted Emissions (Not apply in the report)

The EUT is a placed on as turn table which is 0.8 m above ground plane. According to the requirements in Section 13.1.4.1 of ANSI C63.4-2003. Conducted emissions from the EUT measured in the **frequency range between 0.15 MHz and 30MHz** using **CISPR Quasi-Peak and average detector mode**.

2.3.2 Radiated Emissions

The EUT is a placed on as turn table which is 0.8 m above ground plane. The turn table shall rotate 360 degrees to determine the position of maximum emission level. EUT is set 3m away from the receiving antenna which varied from 1m to 4m to find out the highest emission. And also, each emission was to be maximized by changing the polarization of receiving antenna both horizontal and vertical. In order to find out the max. emission, the relative positions of this hand-held transmitter(EUT) was rotated through three orthogonal axes according to the requirements in Section 13.1.4.1 of ANSI C63.4-2003.

2.4 Limitation

(1) Conducted Emission (Not applicable in this report)

According to section 15.207(a) Conducted Emission Limits is as following.

Frequency range MHz	Limits dB(uV)	
	Quasi-peak	Average
0.15 to 0.50	66 to 56	56 to 46
0.50 to 5	56	46
5 to 30	60	50

Note

- The lower limit shall apply at the transition frequencies
- The limit decreases linearly with the logarithm of the frequency in the range 0.15 MHz to 0.50 MHz.

(2) Radiated Emission

- The field strength of any emission within this band (section 15.227 frequency between 26.95MHz -27.28MHz) shall not exceed 10000 micro volts/meter at 3 meters. (80dBμV at 3m) The emission limit in this paragraph is based on measurement instrumentation employing an average detector. The provisions in section 15.35 for limiting peak emissions apply.
- The field strength of any emissions which appear outside of this band shall not exceed the general radiated emission limits in section 15.209(Intentional Radiators general limit).as below.

Frequency (MHz)	Field strength μV/m	Distance(m)	Field strength at 3m dBμV/m
1.705-30	30	30	69.54
30-88	100	3	40
88-216	150	3	43.5
216-960	200	3	46
Above 960	500	3	54

- Remark:
- Emission level in dBuV/m=20 log (uV/m)
 - Measurement was performed at an antenna to the closed point of EUT distance of meters.
 - Only spurious frequency is permitted to locate within the Restricted Bands specified in provision of § 15.205
 - Emission spurious frequency which appearing within the Restricted Bands specified in provision of §15.205, then the general radiated emission limits in § 15.209 apply.

2.5 Configuration of Tested System

Fig. 2-1 Configuration of Tested System

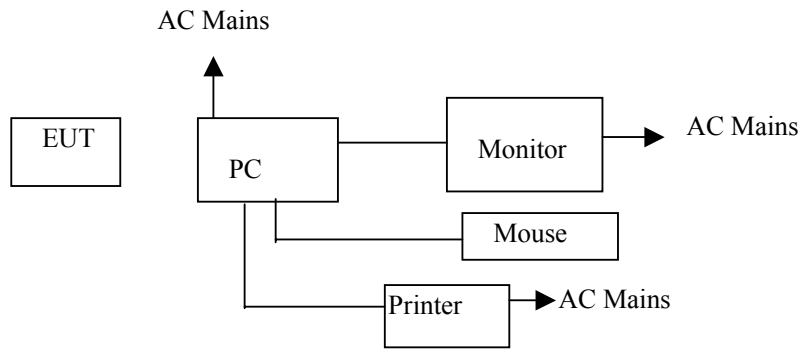

Table 2-1 Equipment Used in Tested System

Item	Equipment	Mfr/Brand	Model/Type No.	FCC ID	Series No.	Note
1.	Wireless Keyboard	Unitek	RF-8105	T5YRFKB8105	N/A	EUT
2.	PC	HEWLETT PACKARD	Vectra VL420 MT	N/A	CN15100363	
3.	LCD Monitor	Sony	SDM-S53	N/A	0413350	
4.	Mouse	HEWLETT PACKARD	M-S48a	N/A	LZE14823966AW	
5.	Printer	HEWLETT PACKARD	C89520	N/A	CN25S182N6	

Note:

- (1) Unless otherwise denoted as EUT in 'Remark' column , device(s) used in tested system is a support equipment.

3. Summary Of Test Results

FCC Rules	Description Of Test	Result
§ 15.207	Conducted Emission	N/A
§ 15.227	Radiated Emission	Compliant
§ 15.227	Bandwidth Test	Compliant

4. Description of test modes

The EUT (Wireless Keyboard) has been tested under normal operating condition.

The EUT stay in continuous transmitting mode. The Frequency 27.095MHz are chosen for testing.

5. Conducted Emissions Test (Not applicable in this report)**5.1 Measurement Procedure:**

1. The EUT was placed on a table which is 0.8m above ground plane.
2. Maximum procedure was performed on the six highest emissions to ensure EUT compliance.
3. Repeat above procedures until all frequency measured were complete.

5.2 Test SET-UP (Block Diagram of Configuration)**5.3 Measurement Equipment Used:**

Conducted Emission Test Site # 4					
EQUIPMENT TYPE	MFR	MODEL NUMBER	SERIAL NUMBER	LAST CAL.	CAL DUE.
Test Receiver	Rohde & Schwarz	ESCS30	828985/018	05/29/2005	05/29/2006
L.I.S.N	Rohde & Schwarz	ESH2-Z5	834549/005	05/29/2005	05/29/2006
L.I.S.N	Rohde & Schwarz	ESH2-Z5	834549/005	05/29/2005	05/29/2006
50ΩCoaxial Switch	Anritsu	MP59B	M20531	005/29/2005	05/29/2006

5.4 Measurement Result:

N/A

5.5 Conducted Measurement Photos:

N/A

6. Radiated Emission Test

6.1 Measurement Procedure

- 1 The EUT was placed on a turn table which is 0.8m above ground plane.
2. Maximum procedure was performed on the six highest emissions to ensure EUT compliance.
3. And also, each emission was to be maximized by changing the polarization of receiving antenna both horizontal and vertical.
4. Repeat above procedures until all frequency measured were complete.

6.2 Test SET-UP (Block Diagram of Configuration)

(A) Radiated Emission Test Set-Up, Frequency Below 30MHz

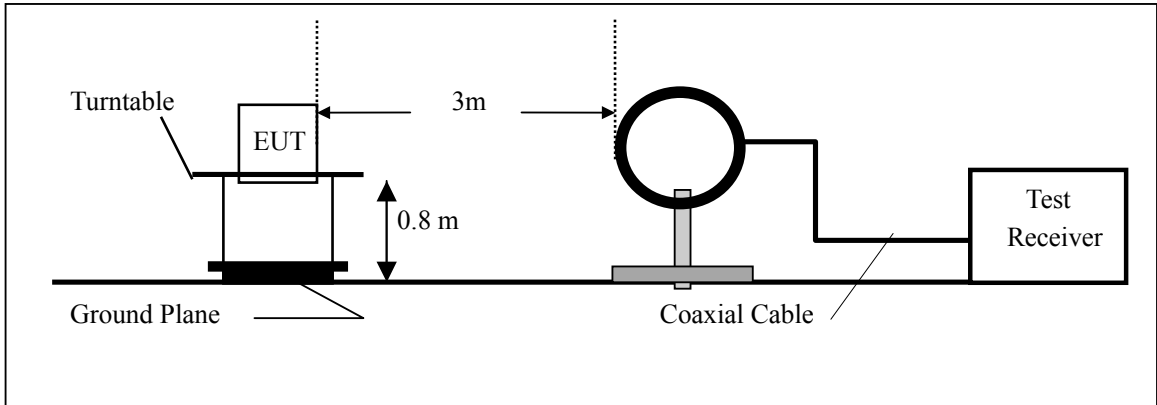

(B) Radiated Emission Test Set-Up, Frequency Below 1000MHz

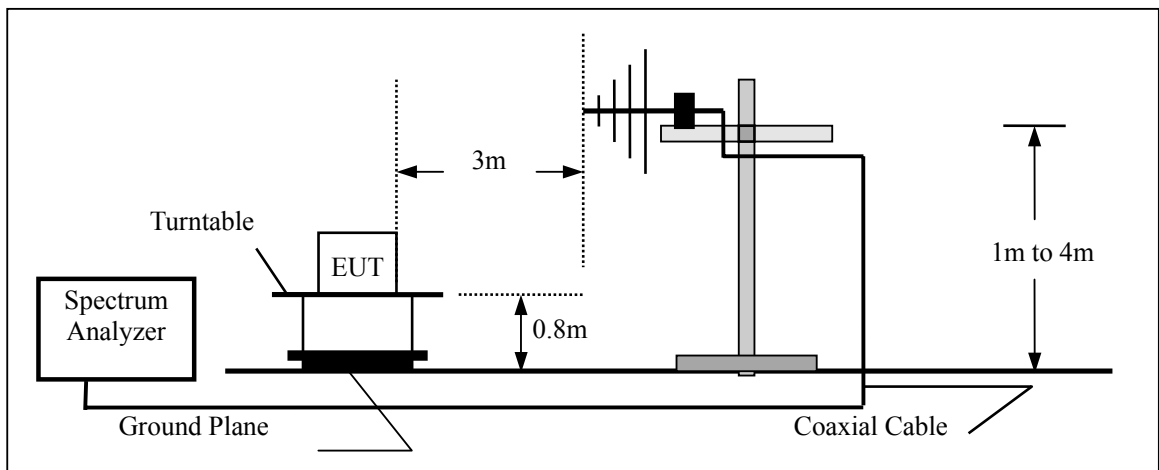

6.3 Measurement Equipment Used:

Open Area Test Site # 3					
EQUIPMENT TYPE	MFR	MODEL NUMBER	SERIAL NUMBER	LAST CAL.	CAL DUE.
Spectrum Analyzer	ANRITSU	MS2661C	6200140915	05/29/2005	05/29/2006
EMI Test Receiver	Rohde & Schwarz	ESCS30	828985/018	05/29/2005	05/29/2006
Pre-Amplifier	HP	8447D	2944A07999	05/29/2005	05/29/2006
Bilog Antenna	Schwarzbeck	VULB9163	142	05/29/2005	05/29/2006
Loop Antenna	ARA	PLA-1030/B	1029	05/29/2005	05/29/2006

6.4 Measurement Result

A. Fundamental Radiated Emission Data

Operation Mode: Transmitting Mode Test Date : April 10, 2006
 Test Item: Fundamental Radiated Emission Data Temperature : 28
 Fundamental Frequency: 27.095 MHz Humidity : 65 %
 Test Result: PASS Test By: Andy

Freq. (MHz)	Ant.Pol. H/V	Emission Level (dBuV)	Limit 3m (dBuV/m)	Margin (dB)	Note
27.095	V	43.80	80.00	-36.20	Peak
27.095	H	40.70	80.00	-39.30	Peak

- Note:**
- (1) All Readings are Peak Value.
 - (2) Emission Level= Reading Level+Probe Factor +Cable Loss
 - (3) The average measurement was not performed when the peak measured data under the limit of average detection.

B. General Radiated Emission Data

Operation Mode: Transmitting Mode Test Date : April 10, 2006
 Test Item: General Radiated Emission Data Temperature : 28
 Fundamental Frequency: 27.095 MHz Humidity : 65 %
 Test Result: PASS Test By: Andy

Freq. (MHz)	Ant.Pol. H/V	Emission Level (dBuV)	Limit 3m (dBuV/m)	Margin (dB)	Note
54.198	V	17.4	40.00	-36.20	Peak
81.297	V	15.2	40.00	-22.60	Peak
108.396	V	18.5	43.50	-24.80	Peak
135.495	V	20.8	43.50	-25.00	Peak
162.594	V	19.1	43.50	-22.70	Peak
189.693	V	23.8	43.50	-24.40	Peak
216.792	V	22.1	46.00	-19.70	Peak
243.891	V	23.2	46.00	-23.90	Peak
270.990	V	22.3	46.00	-22.80	Peak
298.089	V	19.8	46.00	-23.70	Peak
325.188	V	23.1	46.00	-26.20	Peak
352.287	V	26.7	46.00	-22.90	Peak
379.386	V	24.2	46.00	-19.30	Peak
406.485	V	26.1	46.00	-21.80	Peak
433.584	V	25.3	46.00	-19.90	Peak
460.683	V	24.0	46.00	-20.70	Peak
487.782	V	18.7	46.00	-22.00	Peak
54.198	H	19.55	40.00	-20.45	Peak
81.297	H	16.40	40.00	-23.60	Peak
108.396	H	18.30	43.50	-25.20	Peak
135.495	H	22.95	43.50	-20.55	Peak
162.594	H	21.75	43.50	-21.75	Peak
189.693	H	26.45	43.50	-17.05	Peak
216.792	H	25.45	46.00	-20.55	Peak
243.891	H	26.75	46.00	-19.25	Peak
270.990	H	26.05	46.00	-19.95	Peak
298.089	H	25.25	46.00	-20.75	Peak
325.188	H	27.30	46.00	-18.70	Peak
352.287	H	31.30	46.00	-14.70	Peak
379.386	H	31.45	46.00	-14.55	Peak
406.485	H	27.30	46.00	-18.70	Peak
433.584	H	28.65	46.00	-17.35	Peak
460.683	H	26.70	46.00	-19.30	Peak
487.782	H	21.00	46.00	-25.00	Peak

Note: Emission Level= Reading Level+ Probe Factor +Cable Loss

7. Occupied Bandwidth

7.1 Measurement Procedure

1. The EUT was placed on a turn table which is 0.8m above ground plane.
2. Set EUT as normal operation
3. Set SPA Center Frequency = fundamental frequency , RBW,VBW= 10KHz
4. Set SPA Max hold. Mark peak.

7.2 Test SET-UP (Block Diagram of Configuration)

Same as 4.2 Radiated Emission Measurement.

7.3 Measurement Equipment Used:

Same as 4.2 Radiated Emission Measurement.

7.4 Measurement Results:

The field strength of any emissions which appear outside of this band shall not exceed the general radiated emission limits in section 15.209.

Refer to attached data chart.

Band Width Test Data

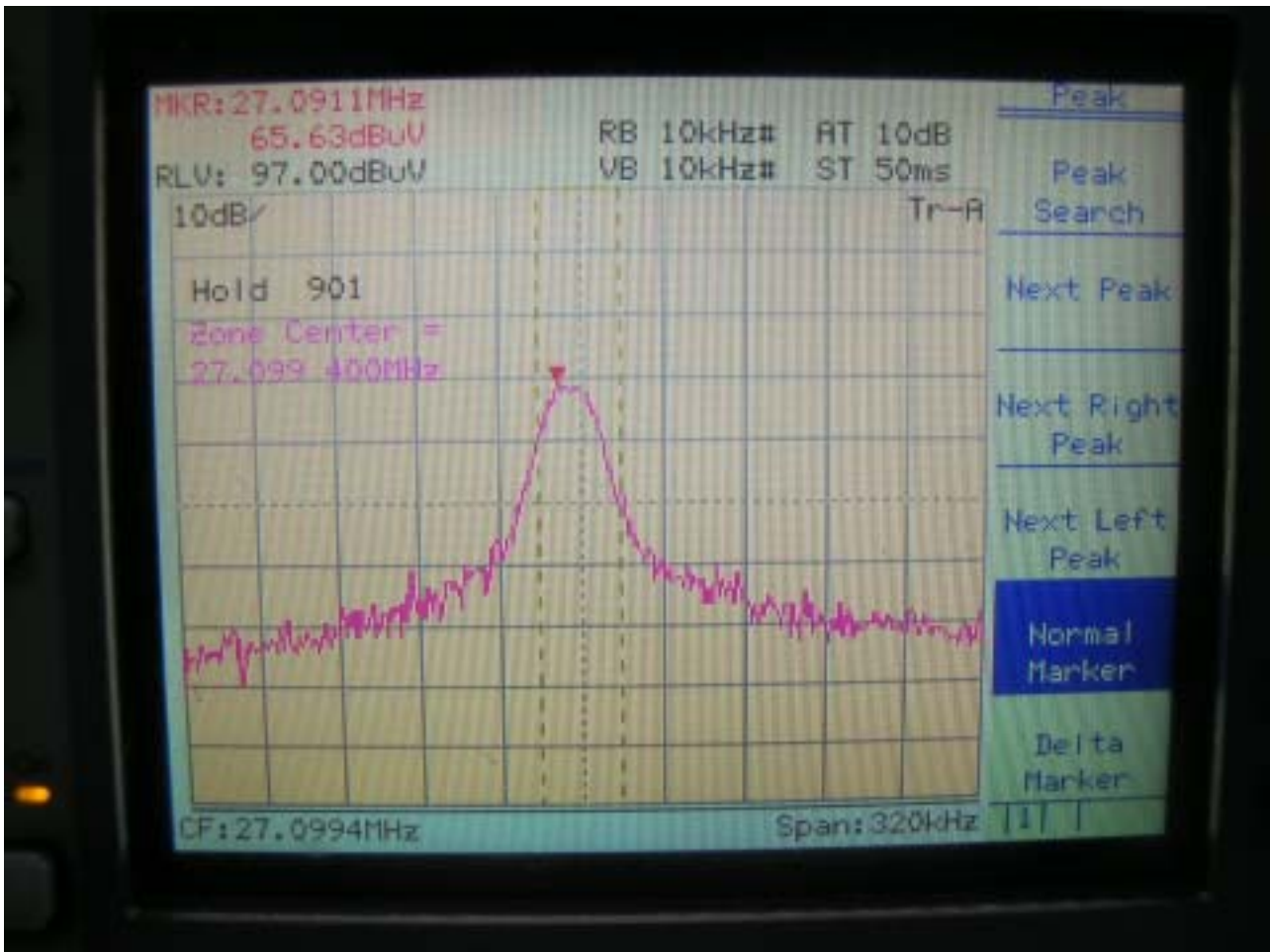

APPENDIX 1

PHOTOGRAPHS OF SET UP

Radiated Emission Setup Photos



APPENDIX 2

PHOTOGRAPHS OF EUT

UP View of TX



Bottom View of TX



Internal of TX- Open



Internal of TX- 1

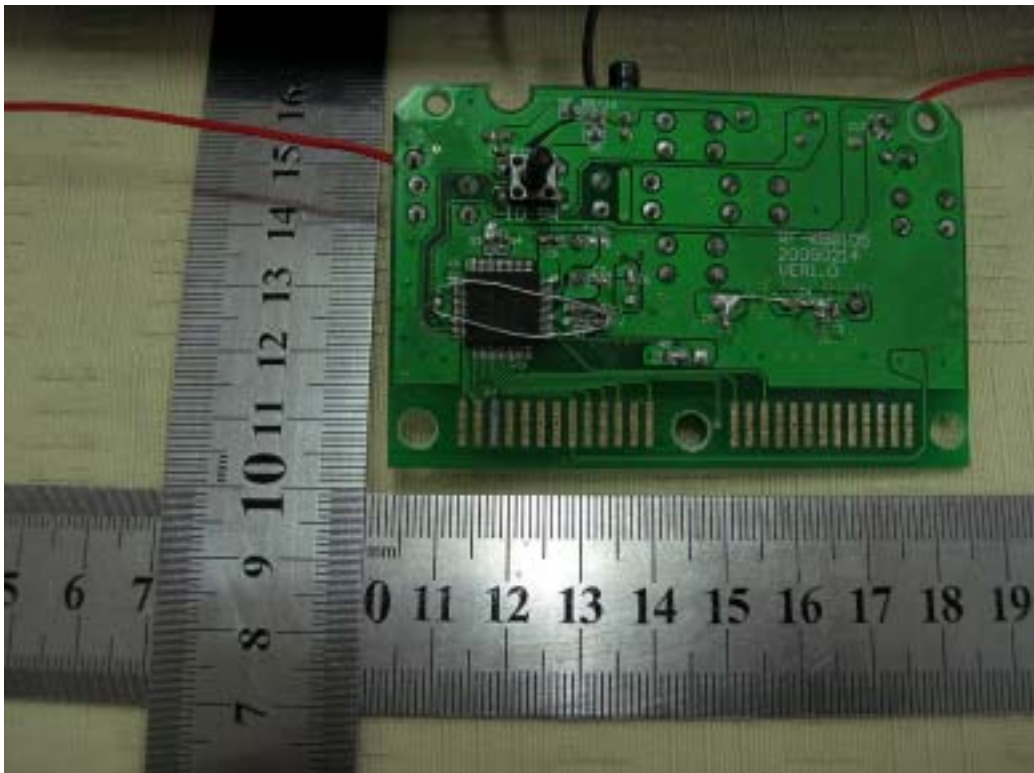

Internal of TX- 2

