



Bluetooth v4.0 Dual-Mode USB HCI Module

Hardware Integration Guide (HIG)

Version 0.2

BT800

global solutions: local support.

Americas: +1-800-492-2320 Option 2

Europe: +44-1628-858-940

Hong Kong: +852-2923-0610

www.lairdtech.com/bluetooth

REVISION HISTORY

Revision	Date	Changes
Version 0.1	7/8/2013	Preliminary
Version 0.2	10/07/13	Initial – KP only

PRELIMINARY

CONTENTS

Revision History	2
Contents	3
1 Scope	5
2 Operational Description.....	5
2.1 Features & Benefits	5
2.2 Application Areas.....	5
3 Module picture	6
4 Block Diagram and Descriptions	7
4.1 Main Chip: CSR8510A10.....	7
4.2 Antenna.....	7
4.3 Band Pass Filter.....	7
4.4 EEPROM	7
4.5 Crystal	7
5 Specifications	8
6 Pin definitions	9
7 DC Electrical Characteristic.....	11
8 RF Characteristics	13
9 Interface	14
9.1 PIO (Programmable I/O Ports)	14
9.2 WLAN Coexistence Interface.....	14
9.3 USB Interface	14
9.4 PCM Interface	15
9.5 GCI Interface.....	17
9.6 Slots and Sample Formats.....	17
9.7 PCM Timing Information.....	18
9.8 PCM Slave Timing	20
9.9 PCM Slave Mode Timing Parameters	20
9.10 PCM_CLK and PCM_SYNC Generation	22
9.11 PCM Configuration.....	22
9.12 Digital Audio Interface (I ² S).....	22
10 Power Control and Regulation	25
10.1 USB Linear Regulator	25
10.2 High-voltage Linear Regulator.....	25
10.3 Low-voltage VDD_DIG Linear Regulator.....	26
10.4 Low-voltage VDD_RADIO Linear Regulator.....	26
10.5 Low-voltage VDD_AUX Linear Regulator	26
10.6 Voltage Regulator Enable and Reset.....	26
10.7 Power Sequencing	26
11 Antenna performance	27
12 Mechanical Dimensions and Land Pattern.....	29
13 Implementation note	30
13.1 PCB Layout on Host PCB	30
14 Application Note for Surface Mount Modules.....	32
14.1 Introduction	32
14.2 Shipping tray.....	32
14.3 Reflow Parameters	32
15 FCC and IC Regulatory.....	34
15.1 Documentation Requirements	34

BT800 Hardware Integration Guide

Version 0.2

16	European Union Regulatory	38
17	EU Declarations of Conformity.....	38
17.1	BT800 / BT810 / BT820	38
18	Ordering Information.....	39
18.1	General Comments	39
19	Bluetooth SIG Approvals	40
	TBC	40

PRELIMINARY

1 SCOPE

This document describes key hardware aspects of the Laird BT800 Bluetooth HCI/HID module. This document is intended to assist device manufacturers and related parties with the integration of this module into their host devices. Data in this document are drawn from a number of sources including data sheets for the CSR CSR8510.

Because the BT800 is currently in development stage, this document is preliminary and the information in this document is subject to change. Please contact Laird Technologies or visit the Laird website at www.Lairdtech.com to obtain the most recent version of this document.

2 OPERATIONAL DESCRIPTION

The BT800 series of USB HCI devices are designed to meet the needs of OEMs adding robust Bluetooth connectivity and using embedded Bluetooth stacks within these products.

Leveraging the market-leading CSR 8510 chipset, the BT800 series provides exceptionally low power consumption with outstanding range. Supporting the latest Bluetooth v4.0 Specification with EDR (Enhanced Data Rate), the Laird BT800 series enables OEMs to accelerate their development time for leveraging either Classic Bluetooth or Bluetooth Low Energy (BLE) into their operating system based devices.

With a tiny footprint as small as 8.5 x 13 mm, yet output power at 8 dBm, these modules are ideal for applications where designers need high performance in minimal size. For maximum flexibility in systems integration, the modules are designed to support a full speed USB interface plus GPIO and additionally I2S and PCM audio interfaces.

These modules present an HCI interface and have native support for Windows and Linux Bluetooth software stacks. All BT800 series devices are fully qualified as Bluetooth Controller Subsystem products. This also allows designers to integrate their existing pre-approved Bluetooth Host and Profile subsystem stacks to gain a Bluetooth END product approval for their products.

The BT800 series is engineered to provide excellent RF performance with integrated antenna and additional band pass filters. It further reduces regulatory and testing requirements for OEMs and ensures a hassle free development cycle. As an additional benefit of the BT800 series, Laird has implemented CSR's HID (Human Interface Device) Proxy Mode enabling out of the box HID connectivity for pointing devices and / or keyboard functionality, requiring zero host device software or configuration.

A fully featured, low-cost developer's kit is available for prototyping, debug and integration testing of the BT800 series modules and further reduces risk and time in development cycles.

2.1 Features & Benefits

- Bluetooth v4.0 - Dual mode
 - Classic Bluetooth and Bluetooth Low Energy
- Compact footprint
- 2-wire and 3-wire Wi-Fi coexistence scheme
- High antenna radiation gain and efficiency
- Good interference rejection for multi-com system (GSM/WCDMA)
- Class 1 output – 8 dBm
- USB, GPIO, I2S, and PCM
- Industrial Temperature Range

2.2 Application Areas

- Medical devices
- ePOS terminals
- Barcode scanners
- Industrial Cable Replacement
- M2M Connectivity
- Automotive Diagnostic Equipment
- Personal Digital Assistants (PDA)
- Bluetooth HID device (keyboard, mouse, and joystick)

BT800 Hardware Integration Guide

Version 0.2

- 64 k EEPROM support for HID Proxy mode
- Bluetooth Controller subsystem
- FCC, IC, CE, and MIC approvals

3 MODULE PICTURE

TBA

PRELIMINARY

4 BLOCK DIAGRAM AND DESCRIPTIONS

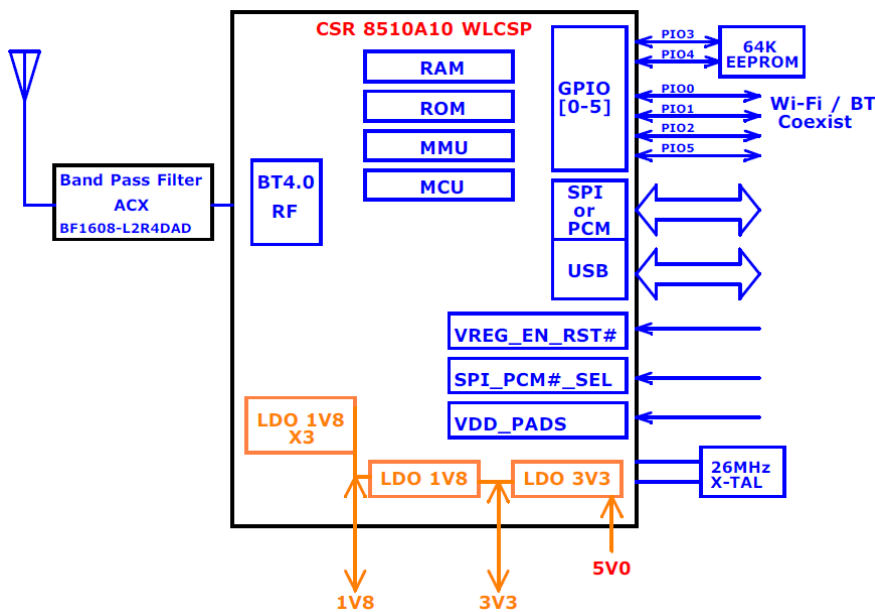

Figure 1: BT800 module block diagram

4.1 Main Chip: CSR8510A10

BT800 is based on CSR8510A10 dual mode chip. The chip is a single-chip radio with on chip LDO regulators and baseband IC for Bluetooth 2.4 GHz systems including EDR to 3 Mbps. Dedicated signal and baseband processing is included for full Bluetooth operation. The chip provides SPI/PCM and USB interfaces. Up to 4 general purpose I/Os are available for general usage, such as Wi-Fi coexistence or general indicators.

4.2 Antenna

Antenna is a ceramic monopole chip antenna.

4.3 Band Pass Filter

The band pass filter filters the out of band emissions from the transmitter to meet the specific regulations for type approvals of various countries.

4.4 EEPROM

There are 64 k bits EEPROM embedded on the BT800 module which can be used to store customizable parameters, such as maximum TX power, PCM configuration, USB product ID, USB vendor ID and USB product description. With that, the BT800 module can support HID/HCI Proxy Mode.

4.5 Crystal

The embedded 26 MHz crystal is used for generating the clock for the entire module.

5 SPECIFICATIONS

CATEGORIES	FEATURE	IMPLEMENTATION
Wireless Specification	Bluetooth®	V4.0 Dual Mode
	Frequency	2.402 - 2.480 GHz
	Max Transmit Power	Class 1 +8dBm from antenna
	Receive Sensitivity	-89dBm
	Range	Circa 100 meters
	Data Rates	Up to 3 Mbps (over the air)
Host Interface	USB	Full Speed USB 2.0
	GPIO	4 configurable lines (1.8V/3.3V configurable by VDD_PADS)
Operational Modes	HCI	Host Controller Interface over USB
	HID Proxy Mode	Human Interface Device
EEPROM	2-wire	64K bits
Coexistence	802.11 (Wi-Fi)	3 wire CSR schemes supported (Unity-3;Unity-3e and Unity+)
Supply Voltage	Supply	5V +/-10% (Note:1)
Power Consumption	Current	Idle (sleep) < TBC mA Connectable & Discoverable < TBC mA
Antenna Option	Internal	Multilayer ceramic antenna with up to 41% efficiency.
Physical	Dimensions	8.5 x 13 x 1.6 mm (BT800 - Module)
		9.3 x 13.05 x 2.3mm (BT810 – Module BG)
		16 x 43 x 11 (BT820 – USB Dongle)
Environmental	Operating	-40C to +85C
	Storage	-40C to +85C
Miscellaneous	Lead Free	Lead-free and RoHS compliant
	Warranty	1 Year
	Bluetooth®	Controller Subsystem Approved
Approvals	FCC / IC / CE / MIC	All BT800 series

Note: Different DC power selections on BT800 are detailed in “

Implementation **note.**

6 PIN DEFINITIONS

#	Pin Name	I/O	Supply Domain	Description
1	SPI_PCM#_SEL	Input with weak internal pull-down	VDD_PADS	High switches SPI/PCM lines to SPI, Low switches SPI/PCM lines to PCM/PIO
2	VDD_HOST	Power supply	(3.1V-3.6V)	USB system positive supply
3	GND	GND	-	Ground
4	USB+	Bidirectional	VDD_HOST	USB data plus with selectable internal 1.5kΩ pull-up resistor
5	USB-	Bidirectional	VDD_HOST	
6	GND	GND	-	Ground
7	VREG_IN_USB	Power supply	Analogue regulator input	Input to USB regulator. Connect to external USB bus supply, e.g. USB_VBUS
8	VREG_EN_RST#	Input with strong internal pull-down	VDD_PADS	Take high to enable internal regulators. Also acts as active low reset. Maximum voltage is VDD_PADS. Note: USB regulator is always enabled and not controlled by this pin
9	VREG_IN_HV	Analogue regulator input / output	3.3V	Input to internal high-voltage regulator to 1.8V regulator, 3.3V output from USB regulator.
10	VREG_OUT_HV	Analogue regulator input / output	1.8V	Output from internal high-voltage to 1.8V regulator. Input to second stage internal regulators.
11	GND	GND	-	Ground
12	GND	GND	-	Ground
13	GND	GND	-	Ground
14	GND	GND	-	Ground
15	GND	GND	-	Ground
16	GND	GND	-	Ground

#	Pin Name	I/O	Supply Domain	Description
17	N/C	-	-	This pin is reserved for future used. No connection.
18	GND	GND	-	Ground
19	PCM_SYNC/ SPI_CS#/ PIO23	Bidirectional, tri-state, with weak internal pull-down	VDD_PADS	PCM synchronous data sync SPI chip select, active low Programmable input/output line
20	PCM_CLK/ SPI_CLK/ PIO24	Bidirectional, tri-state, with weak internal pull-down	VDD_PADS	PCM synchronous data clock SPI clock Programmable input/output line
21	PCM_IN/ SPI_MOSI/ PIO21	Input, tri-state, with weak internal pull- down	VDD_PADS	PCM synchronous data input SPI data input Programmable input/output line
22	PCM_OUT/ SPI_MISO/ PIO22	Output, tri-state, with weak internal pull- down	VDD_PADS	PCM synchronous data output SPI data output Programmable input/output line
23	PIO0/ WLAN_ACTIVE	Bidirectional, tri-state, with weak internal pull- down	VDD_PADS	Programmable input/output line
24	GND	GND	-	Ground
25	PIO1/ BT_PIRORITY	Bidirectional, tri-state, with weak internal pull- down	VDD_PADS	Programmable input/output line
26	PIO2/ BT_ACTIVE	Bidirectional, tri-state, with weak internal pull- down	VDD_PADS	Programmable input/output line
27	VDD_PADS	Power supply	(1.7V-3.6V)	Positive supply for digital I/O pads
28	PIO5	Bidirectional, tri-state, with weak internal pull- down	VDD_PADS	Programmable input/output line

7 DC ELECTRICAL CHARACTERISTIC

Table 1: Absolute maximum ratings

Rating	Min	Max	Unit
Storage temperature	-40	+85	°C
VREG_IN_USB	-0.2	5.75	V
VREG_IN_HV	-0.2	4.9	V
VDD_HOST	-0.2	3.7	V
VDD_PADS	-0.2	3.7	V
Other terminal voltages	VSS - 0.4V	VDD + 0.4 V	V

Table 2: Recommended operating conditions

Rating	Min	Max	Unit
Operating temperature	-40	+85	°C
VREG_IN_USB	4.5	5.5	V
VREG_IN_HV	3.1	3.6	V
VDD_HOST	3.1	3.6	V
VDD_PADS	1.7	3.6	V

Table 3: USB Linear Regulator

Rating	Min	Typ	Max	Unit
Input voltage (VREG_IN_USB)	4.5	5.0	5.5	V
Output voltage (VREG_IN_HV)	3.2	3.3	3.4	V
Output current	-	-	150	mA

Table 4: High-voltage Linear Regulator

Normal Operation	Min	Typ	Max	Unit
Input voltage (VREG_IN_HV)	3.1	3.3	3.6	V
Output voltage (VREG_OUT_HV)	1.75	1.85	1.95	V
Temperature coefficient	-200	-	200	ppm/°C
Output noise (frequency range 100Hz to 100kHz)	-	-	0.4	mV rms
Settling time (settling t_i within 10% of final value)	-	-	5	μs
Output current	-	-	100	mA
Quiescent current (excluding load, $I_{load} < 1mA$)	30	40	60	μA
Low-power Mode				
Quiescent current	14	18	23	μA

(excluding load, Iload < 100µA)

Table 5: Digital I/O Characteristics

Normal Operation	Min	Typ	Max	Unit
Input Voltage				
VIL input logic level low	-0.4	-	0.4	V
VIH input logic level high	0.7 x VDD	-	VDD + 0.4	V
Output Voltage				
VOL output logic level low, IOL = 4.0mA	-	-	0.4	V
VOH output logic level high, IOL = 4.0mA	0.75 x VDD	-	-	V
Input and Tristate Currents				
Strong pull-up	-150	-40	-10	µA
Strong pull-down	10	40	150	µA
Weak pull-up	-5	-1.0	-0.33	µA
Weak pull-down	0.33	1.0	5.0	µA
CI input capacitance	1.0	-	5.0	pF

Table 6: Current Consumption

Normal Operation	Peak (8 dBm)	AVG	Unit
Idle		5	mA
USB Suspend		200	µA
Inquiry	73	51	mA
File Transfer	73	58	mA
LE Connected (Master)	74		mA
LE Scan (Master)	48		mA

8 RF CHARACTERISTICS

Table 7: Receiver Characteristics

RF Characteristics, VDD = 3.3V @ room temperature unless otherwise specified	Min	Typ.	Max	BT. Spec.	Unit
Maximum RF Transmit Power		8	10	20	dBm
RF power variation over temperature range		1.5		-	dB
RF power variation over supply voltage range			0.2	-	dB
RF power variation over BT band		2		-	dB
RF power control range	-21		8	-	dBm
20 dB band width for modulated carrier				1000	kHz
ACP	$F = F_0 \pm 2\text{MHz}$			-20	
	$F = F_0 \pm 3\text{MHz}$			-40	
	$F = F_0 > 3\text{MHz}$			-40	
Drift rate		10		+/-25	kHz
$\Delta F_{1\text{avg}}$		165		140<175	kHz
$\Delta F_{1\text{max}}$		168		140<175	kHz
$\Delta F_{2\text{avg}} / \Delta F_{1\text{avg}}$		0.9		>=0.8	

Table 8: BDR and EDR receiver sensitivity

RF Characteristics, VDD = 3.3V @ room temp.	Packet type	Min	Typ	Max	BT. Spec.	Unit
Sensitivity for 0.1% BER	DH1		-89		-70	dBm
	DH3		-89			dBm
	DH5		-89			dBm
	2-DH5		-92			dBm
	3-DH5		-85			dBm
Sensitivity variation over BT band	All		2			dB
Sensitivity variation over temperature range	All		TBD			dB

9 INTERFACE

9.1 PIO (Programmable I/O Ports)

See the Device Terminal Functions section for the list of supplies to the PIOs.

PIO lines are configured through software to have either weak or strong pull-ups or pull-downs. All PIO lines are configured as inputs with weak pull-downs at reset and have additional individual bus keeper configuration.

9.2 WLAN Coexistence Interface

Dedicated hardware is provided to implement a variety of WLAN coexistence schemes. There is support for:

- Channel skipping AFH
- Priority signalling
- Channel signalling
- Host passing of channel instructions

The BT800 supports the WLAN coexistence schemes:

- Unity-3
- Unity-3e
- Unity+

For more information see Bluetooth and IEEE 802.11 b/g Co-existence Solutions Overview.

9.3 USB Interface

BT800 has a full-speed (12 Mbps) USB interface for communicating with other compatible digital devices. The USB interface on BT800 acts as a USB peripheral, responding to requests from a master host controller.

BT800 supports the Universal Serial Bus Specification, Revision v2.0 (USB v2.0 Specification) and USB Battery Charging Specification, available from <http://www.usb.org>. For more information on how to integrate the USB interface on BT800, see the Bluetooth and USB Design Considerations Application Note.

As well as describing USB basics and architecture, the application note describes:

- Power distribution for high and low bus-powered configurations
- Power distribution for self-powered configuration, which includes USB VBUS monitoring
- USB enumeration
- Electrical design guidelines for power supply and data lines, as well as PCB tracks and effects of ferrite beads
- USB suspend modes and Bluetooth low-power modes:
 - Global suspend
 - Selective suspend, includes remote wake
 - Wake on Bluetooth, includes permitted devices and set-up prior to selective suspend
 - Suspend mode current draw
 - PIO status in suspend mode

- Resume, detach and wake PIOs
- Battery charging from USB: dead battery provision, charge currents, charging in suspend modes and USB
- VBUS voltage consideration
- USB termination when interface is not in use
- internal modules, certification and non-specification compliant operation

9.4 PCM Interface

The audio PCM interface on the BT800 supports:

- Continuous transmission and reception of PCM encoded audio data over Bluetooth.
- Processor overhead reduction through hardware support for continual transmission and reception of PCM data.
- A bidirectional digital audio interface that routes directly into the baseband layer of the firmware. It does not pass through the HCI protocol layer.
- Hardware on BT800 for sending data to and from a SCO connection.
- Up to 3 SCO connections on the PCM interface at any one time.
- PCM interface master, generating PCM_SYNC and PCM_CLK.
- PCM interface slave, accepting externally generated PCM_SYNC and PCM_CLK.
- Various clock formats including:
 - Long Frame Sync
 - Short Frame Sync
 - GCI timing environments
 - 13-bit or 16-bit linear, 8-bit μ -law or A-law companded sample formats.
 - Receives and transmits on any selection of 3 of the first 4 slots following PCM_SYNC.

The PCM configuration options are enabled by setting PSKEY_PCM_CONFIG32.

9.4.1 PCM Interface Master/Slave

When configured as the master of the PCM interface, BT800 generates PCM_CLK and PCM_SYNC.

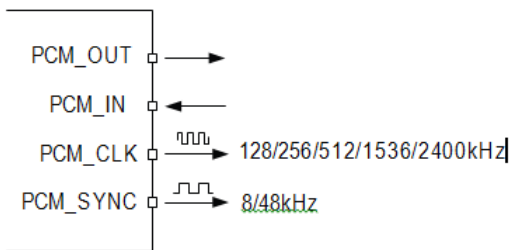

Figure 2: PCM Interface Master

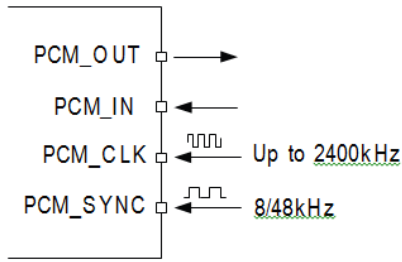

Figure 3: PCM Interface Slave

9.4.2 Long Frame Sync

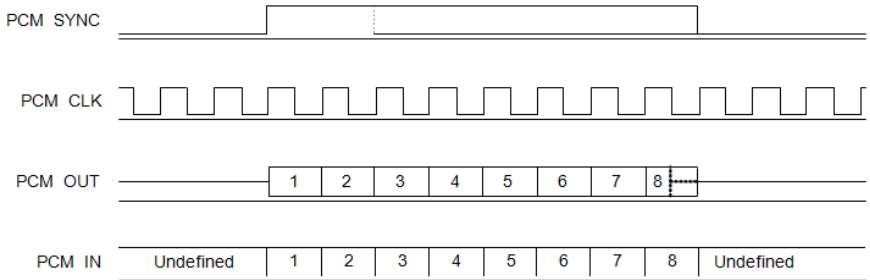

Figure 4: Long Frame Sync (Shown with 8-bit Companded Sample)

Long Frame Sync is the name given to a clocking format that controls the transfer of PCM data words or samples. In Long Frame Sync, the rising edge of PCM_SYNC indicates the start of the PCM word. When BT800 is configured as PCM master, generating PCM_SYNC and PCM_CLK, then PCM_SYNC is 8 bits long. When BT800 is configured as PCM Slave, PCM_SYNC is from 1 cycle PCM_CLK to half the PCM_SYNC rate.

BT800 samples PCM_IN on the falling edge of PCM_CLK and transmits PCM_OUT on the rising edge. PCM_OUT is configurable as high impedance on the falling edge of PCM_CLK in the LSB position or on the rising edge.

9.4.3 Short Frame Sync

In Short Frame Sync, the falling edge of PCM_SYNC indicates the start of the PCM word. PCM_SYNC is always 1 clock cycle long.

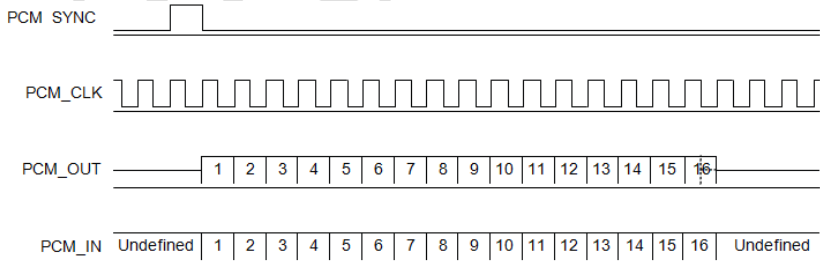

Figure 5: Short Frame Sync (Shown with 16-bit Sample)

As with Long Frame Sync, BT800 samples PCM_IN on the falling edge of PCM_CLK and transmits PCM_OUT on the rising edge. PCM_OUT is configurable as high impedance on the falling edge of PCM_CLK in the LSB position or on the rising edge.

9.4.4 Multi-slot Operation

More than 1 SCO connection over the PCM interface is supported using multiple slots. Up to 3 SCO connections are carried over any of the first 4 slots.

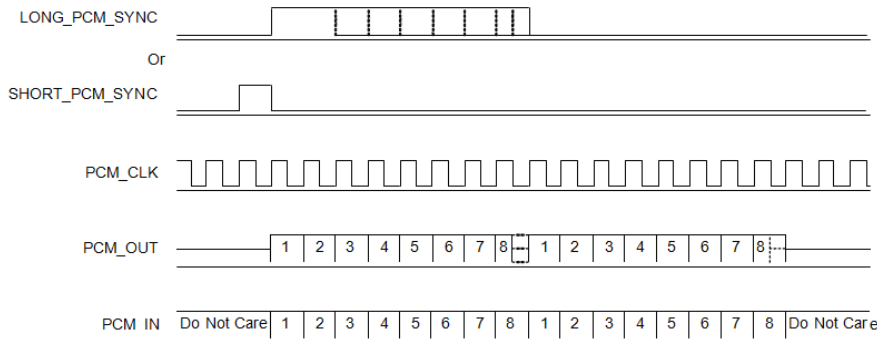

Figure 6: Multi-slot Operation with 2 Slots and 8-bit Companded Samples

9.5 GCI Interface

BT800 is compatible with the GCI, a standard synchronous 2B+D ISDN timing interface. The two 64 kbps B channels are accessed when this mode is configured.

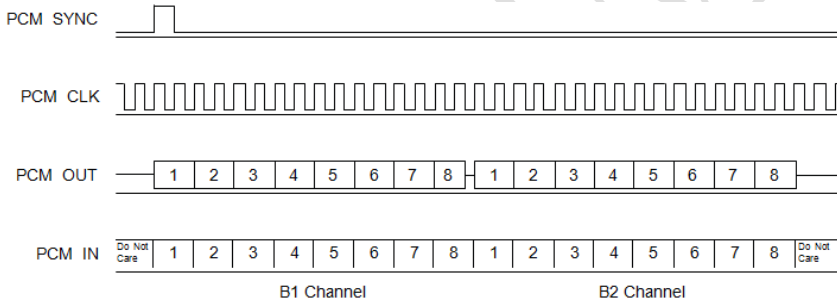

Figure 7: Multi-slot Operation

The start of frame is indicated by the rising edge of PCM_SYNC and runs at 8kHz.

9.6 Slots and Sample Formats

BT800 receives and transmits on any selection of the first 4 slots following each sync pulse. Slot durations are either 8 or 16 clock cycles:

- 8 clock cycles for 8-bit sample formats.
- 16 clock cycles for 8-bit, 13-bit or 16-bit sample formats.

BT800 supports:

- 13-bit linear, 16-bit linear and 8-bit μ -law or A-law sample formats.
- A sample rate of 8ksp/s.
- Little or big endian bit order.
- For 16-bit slots, the 3 or 8 unused bits in each slot are filled with sign extension, padded with zeros or a programmable 3-bit audio attenuation compatible with some codecs.

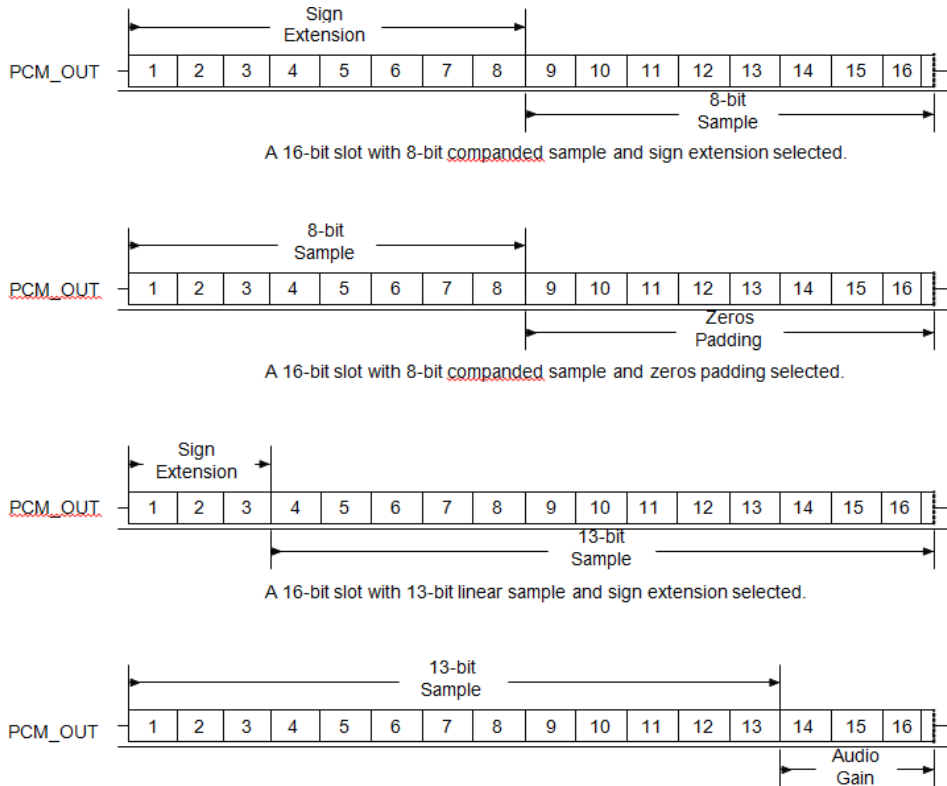

Figure 8: 16-bit Slot Length and Sample Formats

9.7 PCM Timing Information

Table 9: PCM Timing information.

Symbol	Parameter	Min	Typ	Max	Unit
fmclk	PCM_CLK frequency	-	4MHz DDS generation. Frequency selection is programmable.	128	kHz
			48MHz DDS generation. Frequency selection is programmable.	256 512	
-	PCM_SYNC frequency for SCO connection	2.9	-	-	kHz
tmclkh (a)	PCM_CLK high	980	-	-	ns
tmclkl (a)	PCM_CLK low	730	-	-	ns
-	PCM_CLK jitter	-	-	21	ns pk-p

Symbol	Parameter	4MHz DDS generation	48MHz DDS generation	Min	Typ	Max	Unit
tdmclksynch	Delay time from PCM_CLK high to PCM_SYNC high	-	-	-	-	20	ns
		-	-	-	-	40.83	ns
tdmclkpout	Delay time from PCM_CLK high to valid PCM_OUT	-	-	-	-	20	ns
tdmclksyncl	Delay time from PCM_CLK low to PCM_SYNC low (long frame sync only)	-	-	-	-	20	ns
		-	-	-	-	40.83	ns

(a) Assumes normal system clock operation. Figures vary during low-power modes, when system clock speeds are reduced.

Table 10: PCM Master Mode Timing Parameters

Symbol	Parameter	Min	Typ	Max	Unit
tdmclkhsyncl	Delay time from PCM_CLK high to PCM_SYNC low	-	-	20	ns
		-	-	40.83	ns
tdmclkpoutz	Delay time from PCM_CLK low to PCM_OUT high impedance	-	-	20	ns
tdmclhpoutz	Delay time from PCM_CLK high to PCM_OUT high impedance	-	-	20	ns
tsupinclk	Set-up time for PCM_IN valid to PCM_CLK low	20	-	-	ns
thpinclk	Hold time for PCM_CLK low to PCM_IN invalid	0	-	-	ns

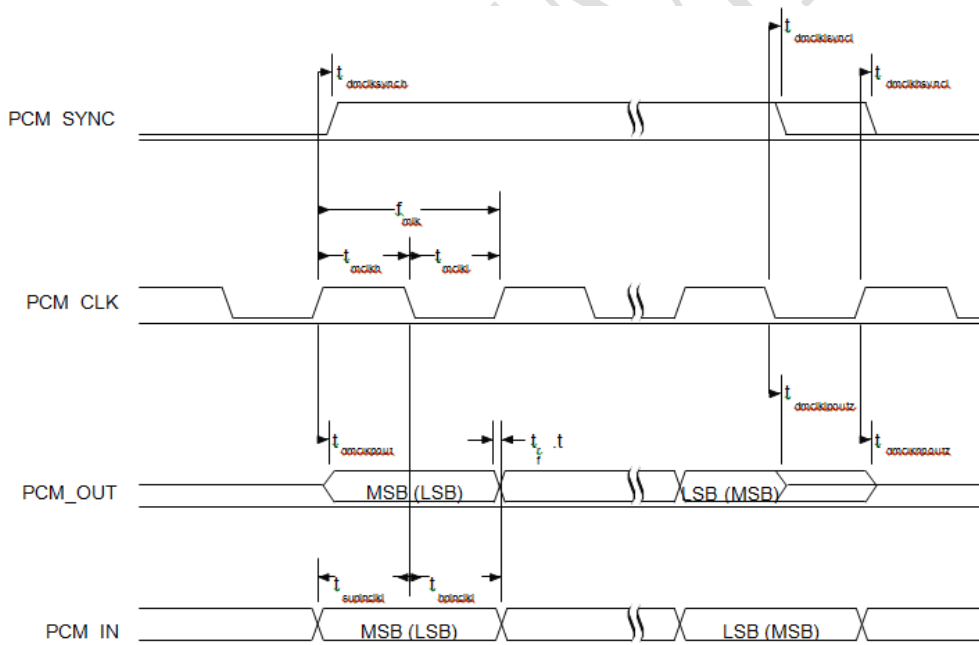

Figure 9: PCM Master Timing Long Frame Sync

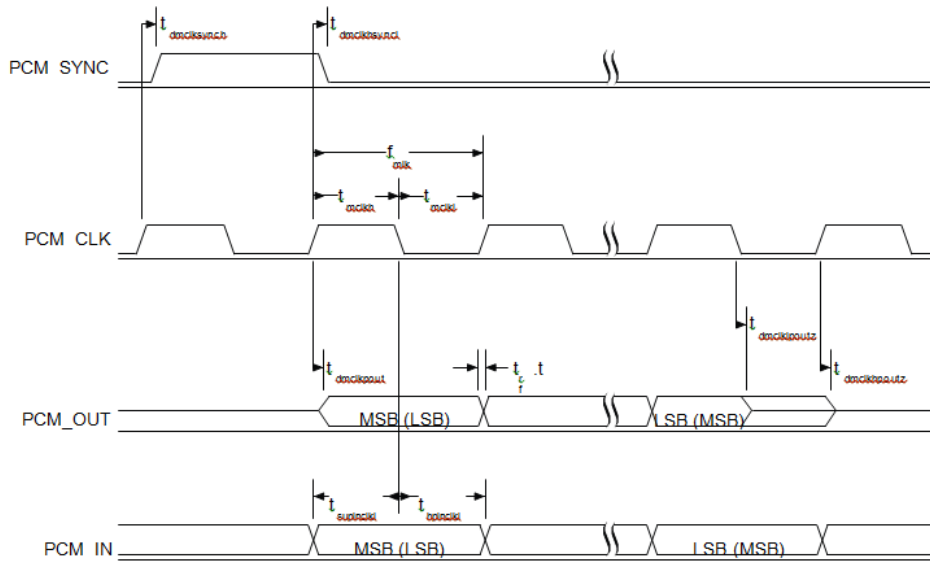

Figure 10: PCM Master Timing Short Frame Sync

9.8 PCM Slave Timing

Symbol	Parameter	Min	Typ	Max	Unit
fclk	PCM clock frequency (Slave mode: input)	64	-	2048	kHz
fclk	PCM clock frequency (GCI mode)	128	-	4096	kHz
tckl	PCM_CLK low time	200	-	-	ns
tckh	PCM_CLK high time	200	-	-	ns

9.9 PCM Slave Mode Timing Parameters

Symbol	Parameter	Min	Typ	Max	Unit
thclkynch	Hold time from PCM_CLK low to PCM_SYNC high	2	-	-	ns
tsusclkynch	Set-up time for PCM_SYNC high to PCM_CLK low	20	-	-	ns
tdpout	Delay time from PCM_SYNC or PCM_CLK, whichever is later, to valid PCM_OUT data (long frame sync only)	-	-	15	ns
tdckhput	Delay time from CLK high to PCM_OUT valid data	-	-	15	ns
tdpoutz	Delay time from PCM_SYNC or PCM_CLK low, whichever is later, to PCM_OUT data line high impedance	-	-	20	ns

$t_{supinsclk}$	Set-up time for PCM_IN valid to CLK low	20	-	-	ns
$t_{hpinsclk}$	Hold time for PCM_CLK low to PCM_IN invalid	2	-	-	ns

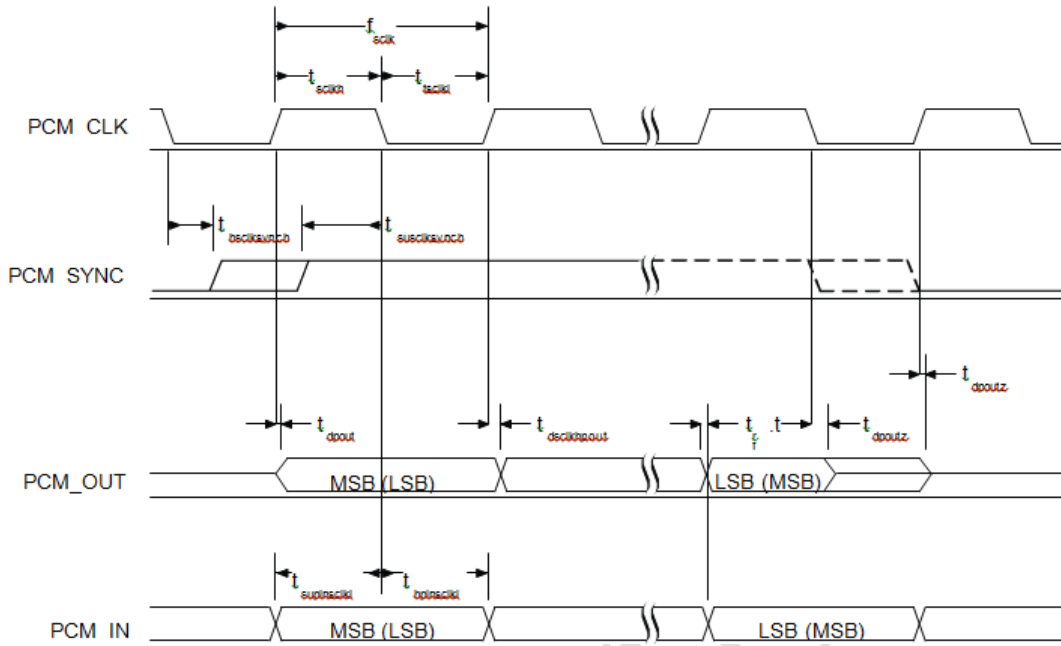

Figure 11: PCM Slave Timing Long Frame Sync

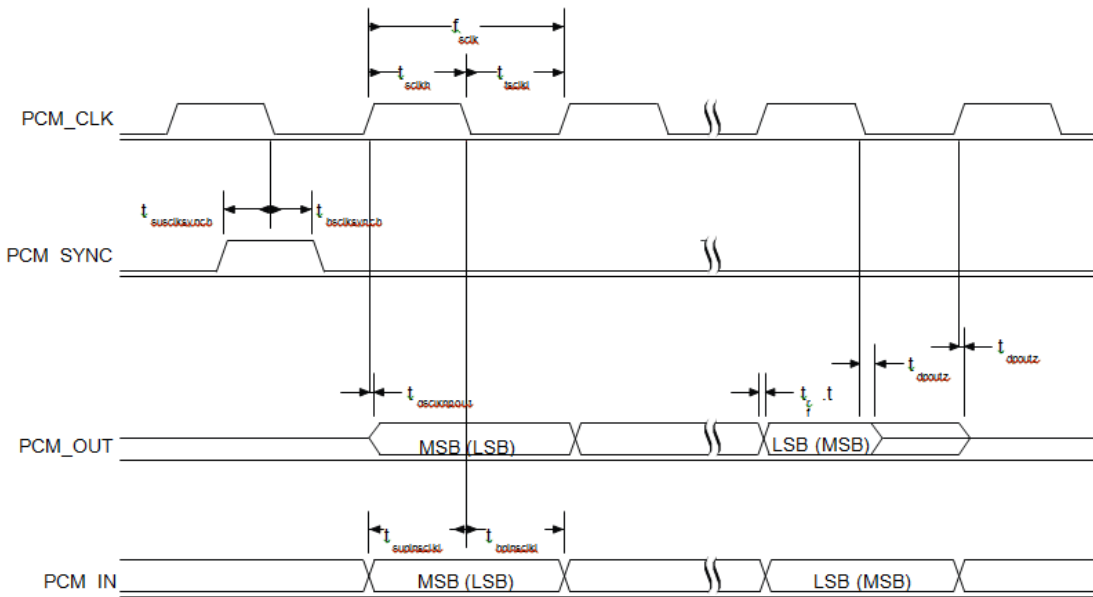

Figure 12: PCM Slave Timing Short Frame Sync

9.10 PCM_CLK and PCM_SYNC Generation

BT800 has 2 methods of generating PCM_CLK and PCM_SYNC in master mode:

- Generating these signals by DDS from BT800 internal 4MHz clock. Using this mode limits PCM_CLK to 128, 256 or 512kHz and PCM_SYNC to 8kHz.
- Generating these signals by DDS from an internal 48MHz clock, which enables a greater range of frequencies to be generated with low jitter but consumes more power. To select this second method set bit 48M_PCM_CLK_GEN_EN in PSKEY_PCM_CONFIG32. When in this mode and with long frame sync, the length of PCM_SYNC is either 8 or 16 cycles of PCM_CLK, determined by LONG_LENGTH_SYNC_EN in PSKEY_PCM_CONFIG32.

Equation 9.1 describes PCM_CLK frequency when generated from the internal 48MHz clock:

$$f = \frac{\text{CNT_RATE}}{\text{CNT_LIMIT}} \times 24\text{MHz}$$

Equation 9.1: PCM_CLK Frequency Generated Using the Internal 48MHz Clock

Set the frequency of PCM_SYNC relative to PCM_CLK using Equation 9.2:

$$f = \frac{\text{PCM_CLK}}{\text{SYNC_LIMIT} \times 8}$$

Equation 9.2: PCM_SYNC Frequency Relative to PCM_CLK

CNT_RATE, CNT_LIMIT and SYNC_LIMIT are set using PSKEY_PCM_LOW_JITTER_CONFIG. As an example, to generate PCM_CLK at 512kHz with PCM_SYNC at 8kHz, set SKEY_PCM_LOW_JITTER_CONFIG to 0x08080177.

9.11 PCM Configuration

Configure the PCM by using PSKEY_PCM_CONFIG32 and PSKEY_PCM_LOW_JITTER_CONFIG, see your PSKey file. The default for PSKEY_PCM_CONFIG32 is 0x00800000, i.e. first slot following sync is active, 13-bit linear voice format, long frame sync and interface master generating 256kHz PCM_CLK from 4MHz internal clock with no tri-state of PCM_OUT.

9.12 Digital Audio Interface (I²S)

The digital audio interface supports the industry standard formats for I²S, left-justified or right-justified. The interface shares the same pins as the PCM interface, which means each audio bus is mutually exclusive in its usage. Table 11 lists these alternative functions. Fig.13 shows the timing diagram.

Table 11: Alternative Functions of the Digital Audio Bus Interface on the PCM Interface.

PCM Interface	I ² S Interface
PCM_OUT	SD_OUT
PCM_IN	SD_IN
PCM_SYNC	WS

PCM_CLK SCK

Configure the digital audio interface using PSKEY_DIGITAL_AUDIO_CONFIG, see BlueCore Audio API Specification and the PS Key file.

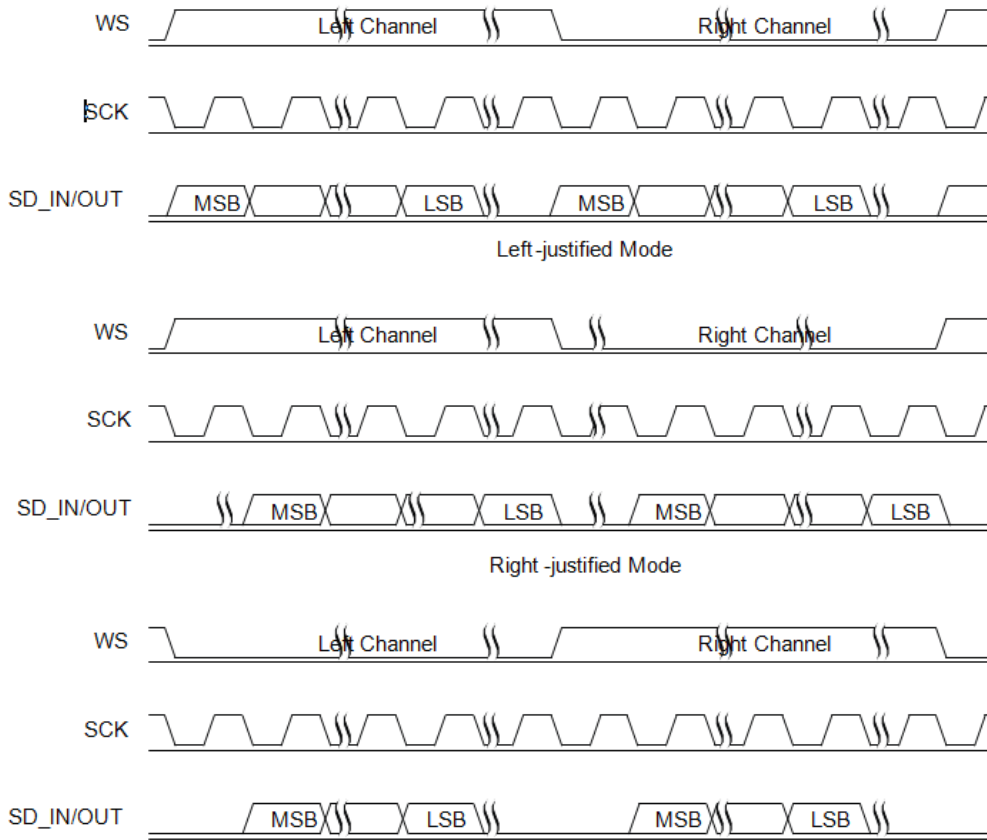

Figure 13: PCM Configuration

The internal representation of audio samples within BT800 is 16-bit and data on SD_OUT is limited to 16-bit per channel.

Table 12: Digital Audio Interface Slave Timing

Symbol	Parameter	Min	Typ	Max	Unit
-	SCK Frequency	-	-	6.2	MHz
-	WS Frequency	-	-	96	kHz
t _{ch}	SCK high time	80	-	-	ns
t _{cl}	SCK low time	80	-	-	ns

Table 13: I²S Slave Mode Timing

Symbol	Parameter	Min	Typ	Max	Unit
t _{ssu}	WS valid to SCK high set-up time	20	-	-	ns
t _{sh}	SCK high to WS invalid hold time	2.5	-	-	ns

t_{opd}	SCK low to SD_OUT valid delay time	-	-	20	ns
t_{isu}	SD_IN valid to SCK high set-up time	20	-	-	ns
t_{ih}	SCK high to SD_IN invalid hold time	2.5	-	-	ns

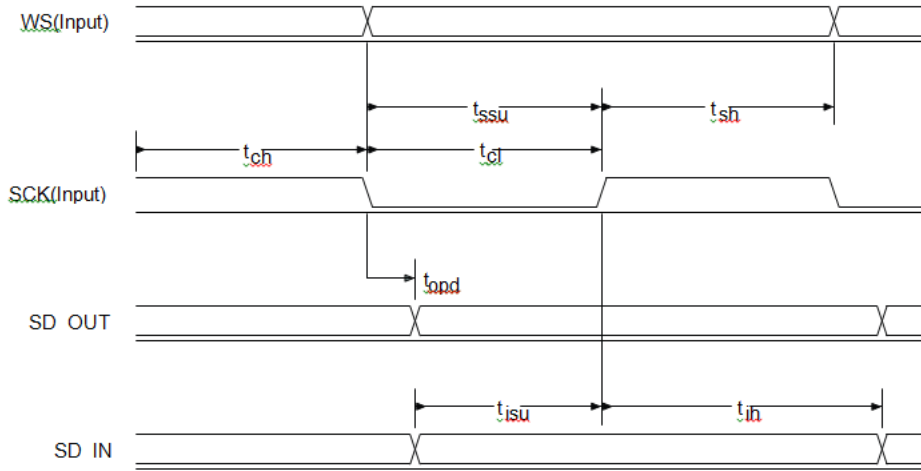

Figure 14: Digital Audio Interface Slave Timing

Table 14: Digital Audio Interface Master Timing

Symbol	Parameter	Min	Typ	Max	Unit
-	SCK Frequency	-	-	6.2	MHz
-	WS Frequency	-	-	96	kHz

Table 15: I²S Master Mode Timing Parameters, WS and SCK as Outputs

Symbol	Parameter	Min	Typ	Max	Unit
t_{spd}	SCK low to WS valid delay time	-	-	39.27	ns
t_{opd}	SCK low to SD_OUT valid delay time	-	-	18.44	ns
t_{isu}	SD_IN valid to SCK high set-up time	18.44	-	-	ns
t_{ih}	SCK high to SD_IN invalid hold time	0	-	-	ns

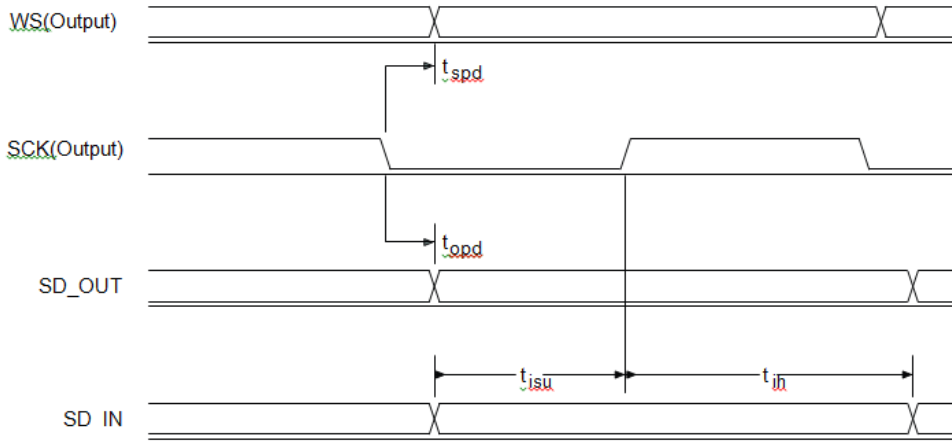

Figure 15: Digital Audio Interface Master Timing

10 POWER CONTROL AND REGULATION

See the Example Application Schematic for the regulator configuration. BT800 contains 5 regulators:

- USB linear regulator, to generate the 3.3 V for the USB interface and the input to the high-voltage linear regulator.
- High-voltage linear regulator, to generate the main 1.8V from the USB linear regulator or an external 3.3V.
- This regulator then feeds the 3 low-voltage regulators:
- Low-voltage VDD_DIG linear regulator, a programmable low-voltage regulator to supply a 0.90V to 1.25V digital supply, VDD_DIG.
- Low-voltage VDD_ANA linear regulator, to supply the radio supply, VDD_RADIO.
- Low-voltage VDD_AUX linear regulator, to supply the auxiliary supply, VDD_AUX.

10.1 USB Linear Regulator

The integrated USB LDO linear regulator is available as a 3.30V supply rail and is intended to supply the USB interface and the high-voltage linear regulator. The input voltage range is between 4.25V and 5.75V. The maximum current from this regulator is 150mA, of which 50mA is available for external use, for example EEPROM/LED. Externally decouple the output of this regulator using a low ESR MLC capacitor to the VREG_IN_HV pin. The regulator operates correctly with an output capacitor of 1µF to 4.7µF (±20%).

This regulator is enabled by default. If the USB linear regulator is not required, leave its input (VREG_IN_USB) unconnected.

10.2 High-voltage Linear Regulator

The integrated high-voltage linear regulator is available to power the main 1.8 V supply rail. The input voltage range is between 2.3 V and 4.8 V. The maximum current from this regulator is 100 mA. Externally decouple the output of this regulator using a low ESR MLC capacitor of a minimum 1.5 µF to the VREG_OUT_HV pin. Take VREG_EN_RST# high to enable this regulator. If this regulator is not required then leave VREG_IN_HV unconnected or tied to VREG_OUT_HV.

10.3 Low-voltage VDD_DIG Linear Regulator

The integrated low-voltage VDD_DIG linear regulator is available to power a 0.90 V to 1.25 V supply rail which includes the digital circuits on CSR8510 WLCSP. The input voltage range is between 1.70 V and 1.95 V.

Externally decouple the output of this regulator using a low ESR MLC capacitor of a minimum 1.5 μ F to the VDD_DIG pin. Software enables and controls the output voltage.

10.4 Low-voltage VDD_RADIO Linear Regulator

The integrated low-voltage VDD_RADIO linear regulator is available to power a 1.35 V analogue supply rail which includes the radio circuits on CSR8510 WLCSP. The input voltage range is between 1.70 V and 1.95 V. Externally decouple the output of this regulator using a low ESR MLC capacitor of a minimum 1.5 μ F to the VDD_RADIO pin. Software enables and controls the output voltage. The regulator is disabled when BT800 is in deep sleep or reset.

10.5 Low-voltage VDD_AUX Linear Regulator

The integrated low-voltage VDD_AUX linear regulator is available to power a 1.35V auxiliary supply rail which includes the VDD_AUX supply on CSR8510 WLCSP. The input voltage range is between 1.70V and 1.95V.

Externally decouple the output of this regulator using a low ESR MLC capacitor of a minimum 470nF to the VDD_AUX pin. Take VREG_EN_RST# high to enable this regulator. Software controls the output voltage.

10.6 Voltage Regulator Enable and Reset

A single pin VREG_EN_RST# controls both the regulator enables and the digital reset function. All the regulators are enabled, except the USB linear regulator, by taking the VREG_EN_RST# pin above 1V. Software also controls the regulators. The VREG_EN_RST# pin is connected internally to the reset function and is powered from VDD_HOST, so do not apply voltages above VDD_HOST to the VREG_EN_RST# pin. The REG_EN_RST# pin is pulled down internally before the software starts. The VREG_EN_RST# pin is an active low reset. Assert the reset signal for a period >5ms to ensure a full reset.

Note: The regulator enables are released as soon as VREG_EN_RST# is low, so the regulators shut down. Therefore do not take VREG_EN_RST# low for less than 5ms, as a full reset is not guaranteed.

Other reset sources are:

**Power-on reset
Via a software-configured watchdog timer**

A warm reset function is also available under software control. After a warm reset the RAM data remains available.

10.7 Power Sequencing

CSR recommends that the power supplies are all powered at the same time. The order of powering the supplies relative to the I/O supply, VDD_PADS to VDD_HOST, is not important. If the I/O supply is powered before VDD_DIG, all digital I/Os are weak pull-downs irrespective of the reset state.

11 ANTENNA PERFORMANCE

The following diagrams illustrate antenna performance.

Gain Table

Unit in dBi @2.44GHz	XY-plane		XZ-plane		YZ-plane		Efficiency
	Peak	Avg.	Peak	Avg.	Peak	Avg.	
A1	-3.5	-4.2	3.8	-5.3	3.2	-4.7	41.0%

Figure 16: BT800 Gain Table

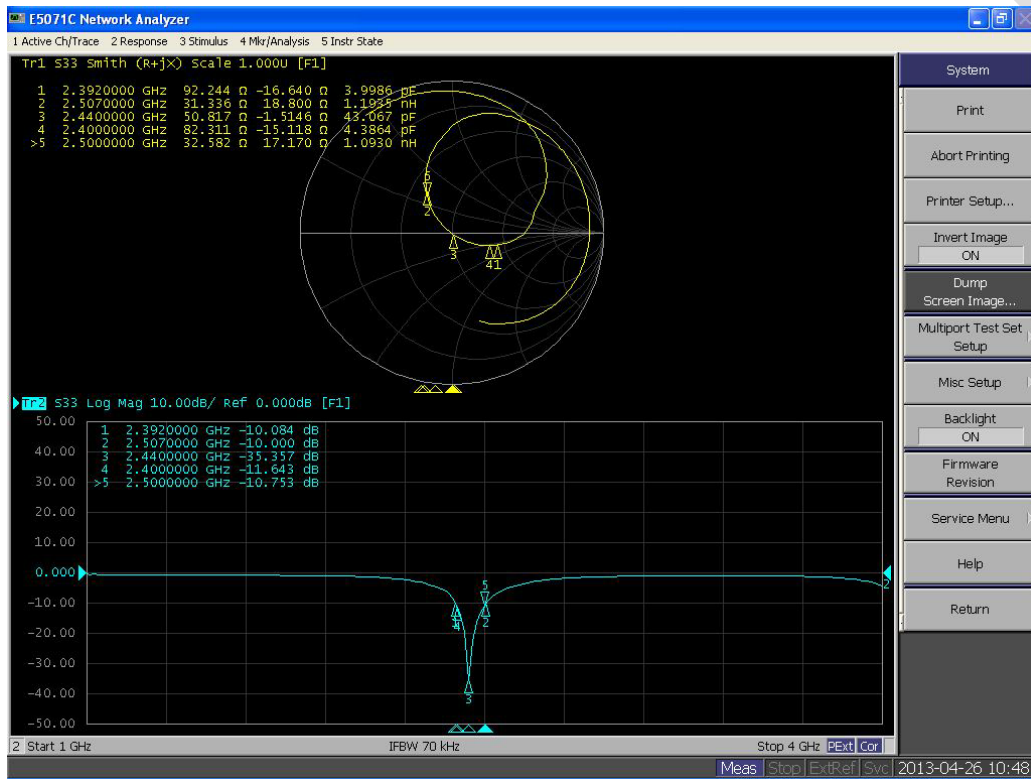
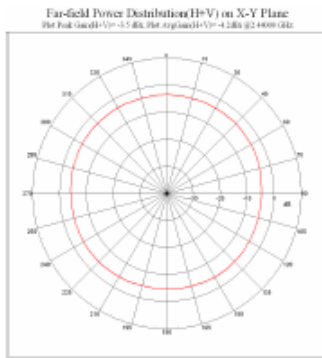

Figure 17: Network Analyzer output

◆ XY-plane



Unit : dBi

	Peak gain	Avg. gain
XY-plane	-3.5	-4.2

◆ XZ-plane

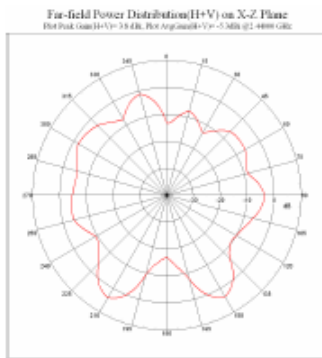

	Peak gain	Avg. gain
XZ-plane	3.8	-5.3

◆ YZ-plane

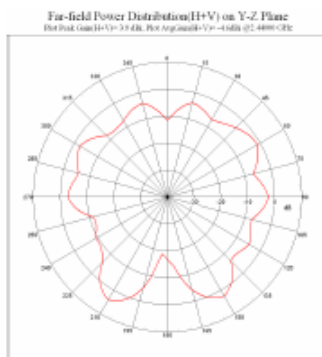

	Peak gain	Avg. gain
YZ-plane	3.2	-4.7

12 MECHANICAL DIMENSIONS AND LAND PATTERN

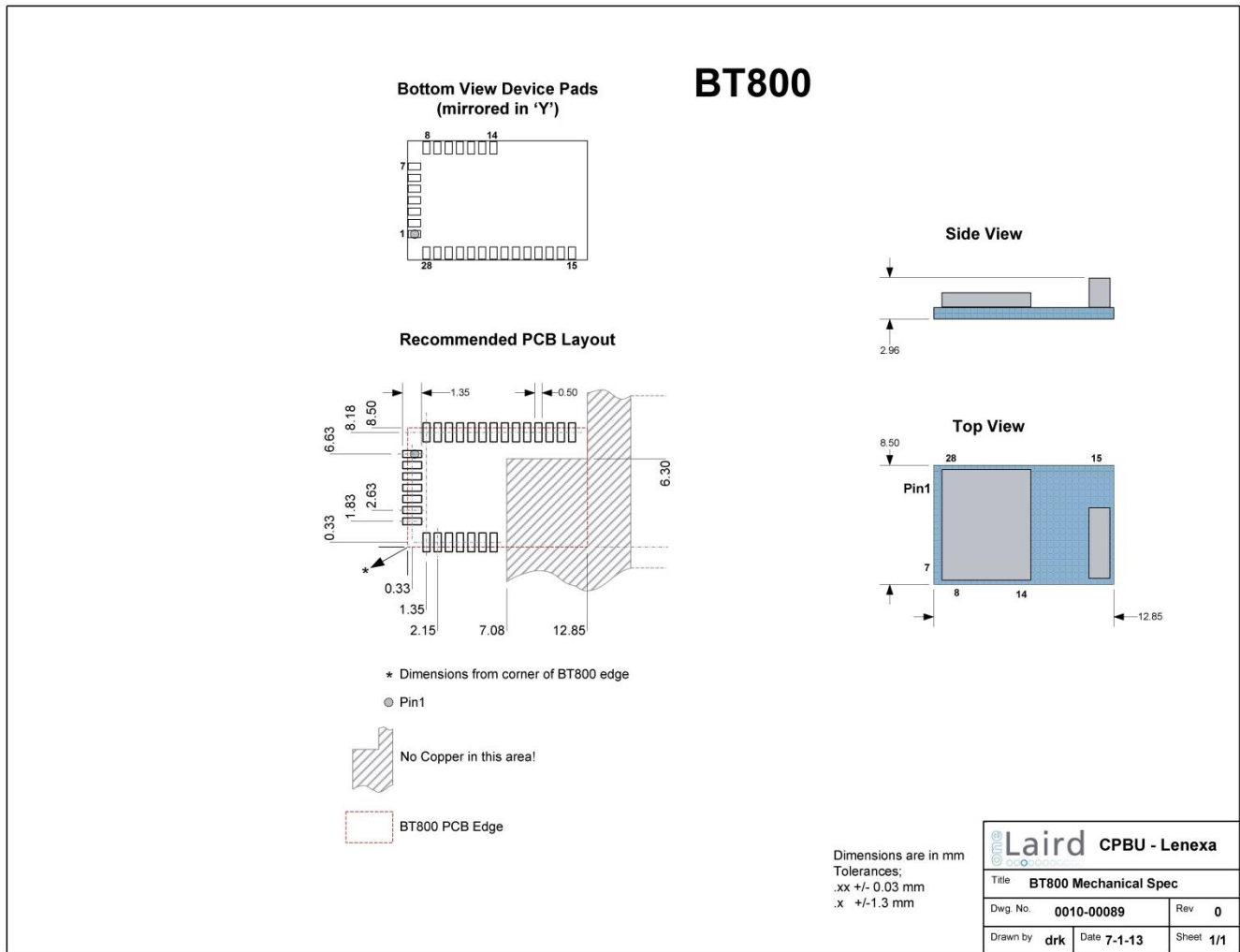

Note: Dimensions are in mm.

13 IMPLEMENTATION NOTE

13.1 PCB Layout on Host PCB

Checklist (for PCB):

- MUST locate BT800/BT810 module close to the edge of PCB.
- Use solid GND plane on inner layer (for best EMC and RF performance).
- Place GND vias close to module GND pads as possible
- Route traces to avoid noise being picked up on VCC supply.
- Antenna Keep-out area:
 - Ensure there is no copper in the antenna keep-out area on any layers of the host PCB.
 - Keep all mounting hardware and metal clear of the area to allow proper antenna radiation.
 - For best antenna performance, place the BT800 module on the edge of the host PCB, preferably in the corner with the antenna facing the corner.
 - A different host PCB thickness dielectric will have small effect on antenna.

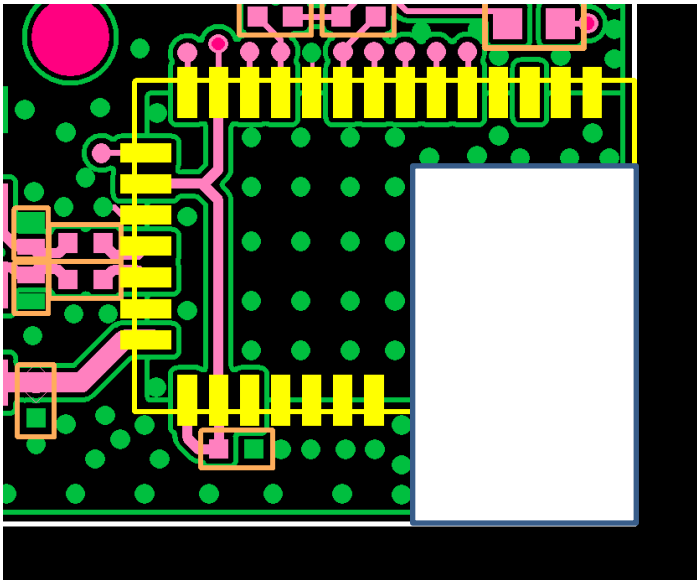

Figure 18: Recommend Antenna keep-out area (in White) used on the BT800

13.1.1 Antenna keep-out and Proximity to Metal or Plastic

Checklist (for metal /plastic enclosure):

- Minimum safe distance for metals without seriously compromising the antenna (tuning) is 40mm top/bottom and 30mm left or right.
- Metal close to the BT800 chip monopole antenna (bottom, top, left, right, any direction) will have degradation on the antenna performance. How much; that is entirely system dependent which means some testing by customer required (in their host application).
- Anything metal closer than 20mm will start to significantly degrade performance (S11, gain, radiation efficiency).
- It is best that the customer tests the Range with mock-up (or actual prototype) of the product to assess effects of enclosure height (and material whether metal or plastic).

13.1.2 USB dongle design example using BT800

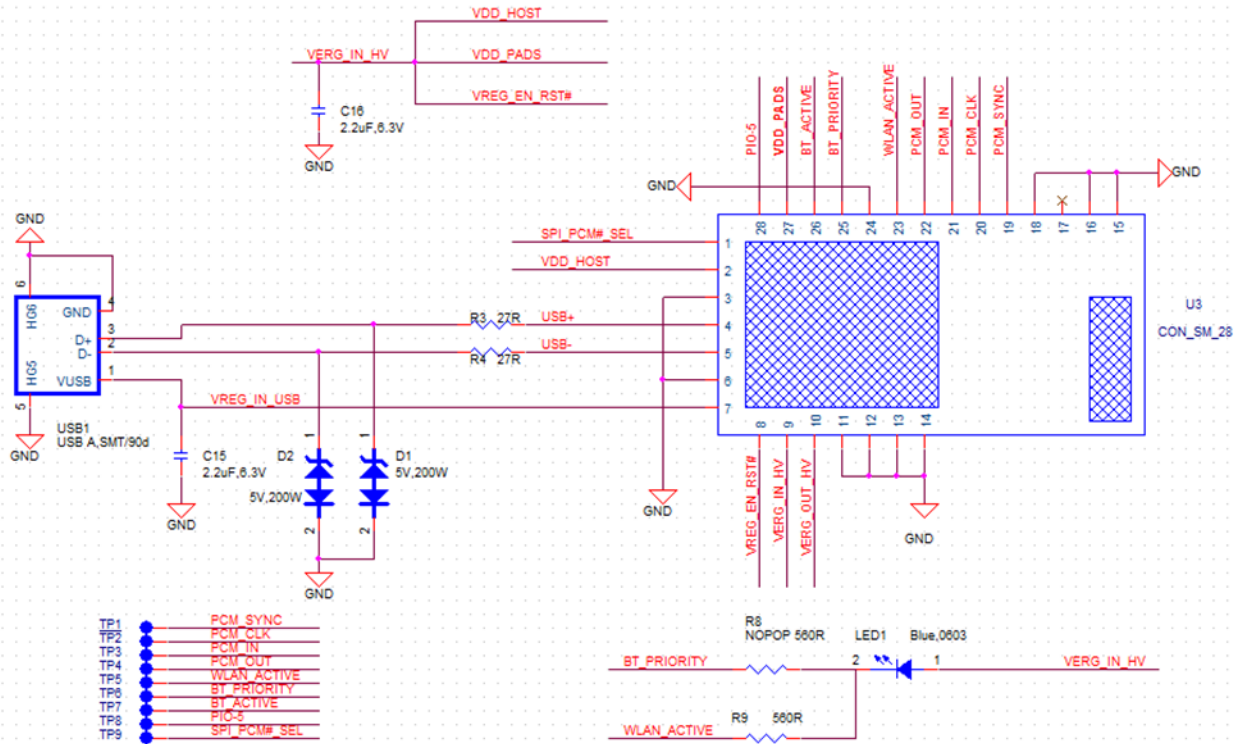

Figure 19: USB Dongle Design Schematic

13.1.3 DC power supply options for using BT800 module

- Using USB bus power (5V +/- 10%)**
 Apply USB bus power (5V +/- 10%) directly to the Pin-7 (VREG_IN_USB) and pull-high on Pin-8 (VREG_EN_RST#) to turn on the internal regulator. The BT800 module will generate 3.3V/1.8V output on Pin-9 (VREG_IN_HV)/Pin-10 (VREG_OUT_HV) that can supply to the other DC pin of the board.
- Using DC power 3.3V**
 Leave the Pin-7 (VREG_IN_USB) no connection, power the on Pin-9 (VREG_IN_HV) with 3.3V and pull-high on Pin-8 (VREG_EN_RST#) to turn on the internal regulator. The BT800 module will generate 1.8V output on Pin-10 (VREG_OUT_HV) which can supply to the other DC pin of the board.

14 APPLICATION NOTE FOR SURFACE MOUNT MODULES

14.1 Introduction

Laird Technologies surface mount modules are designed to conform to all major manufacturing guidelines. This application note is intended to provide additional guidance beyond the information that is presented in the User Manual. This Application Note is considered a living document and will be updated as new information is presented.

The modules are designed to meet the needs of a number of commercial and industrial applications. They are easy to manufacture and conform to current automated manufacturing processes.

14.2 Shipping tray

Modules are shipped in ESD (Electrostatic Discharge) safe trays that can be loaded into most manufacturers pick and place machines. Layouts of the trays are provided in.

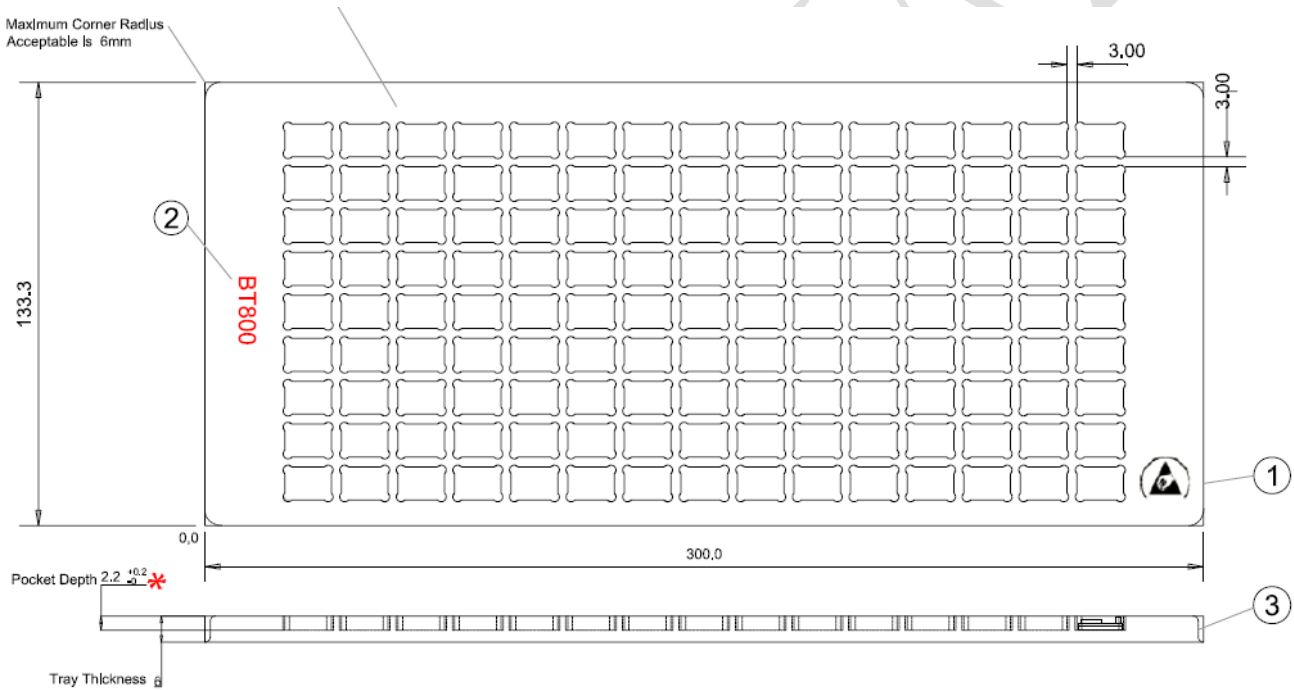

Figure 20: Shipping tray layout

14.3 Reflow Parameters

Laird Technologies surface mount modules are designed to be easily manufactured, including reflow soldering to a PCB. Ultimately it is the responsibility of the customer to choose the appropriate solder paste and to ensure oven temperatures during reflow meet the requirements of the solder paste. Laird Technologies' surface mount modules conform to J-STD-020D1 standards for reflow temperatures.

Important: During reflow, modules should not be above 260° and not for more than 30 seconds.

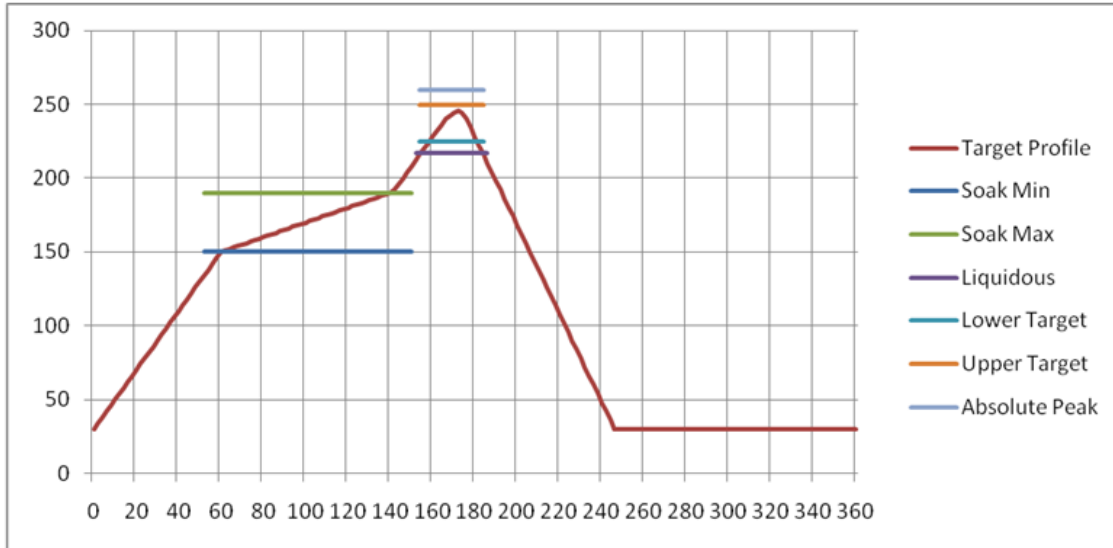

Figure 14-21: Recommended Reflow Temperature

Temperatures should not exceed the minimums or maximums presented in Table 16.

Table 16: Recommended Maximum and minimum temperatures

Specification	Value	Unit
Temperature Inc./Dec. Rate (max)	1~3	°C / Sec
Temperature Decrease rate (goal)	2-4	°C / Sec
Soak Temp Increase rate (goal)	.5 - 1	°C / Sec
Flux Soak Period (Min)	70	Sec
Flux Soak Period (Max)	120	Sec
Flux Soak Temp (Min)	150	°C
Flux Soak Temp (max)	190	°C
Time Above Liquidous (max)	70	Sec
Time Above Liquidous (min)	50	Sec
Time In Target Reflow Range (goal)	30	Sec
Time At Absolute Peak (max)	5	Sec
Liquidous Temperature (SAC305)	218	°C
Lower Target Reflow Temperature	240	°C
Upper Target Reflow Temperature	250	°C
Absolute Peak Temperature	260	°C

15 FCC AND IC REGULATORY

Model	US/FCC	CANADA/IC
BT800	SQGBT800	3147A-BT800
BT810	SQGBT800	3147A-BT800
BT820	SQGBT800	3147A-BT800

The BT800 family has been designed to operate with the antenna listed below having a maximum gain of 0.5 dBi. The required antenna impedance is 50 ohms.

Item	Part Number	Mfg.	Type	Gain (dBi)
1	AT3216-B2R7HAA	ACX	Ceramic	0.5

15.1 Documentation Requirements

In order to ensure regulatory compliance, when integrating the BT800 into a host device, it is necessary to meet the documentation requirements set forth by the applicable regulatory agencies. The following sections (FCC, Industry Canada, and European Union) outline the information that may be included in the user's guide and external labels for the host devices into which the BT800 is integrated.

FCC

Note: You must place "Contains FCC ID: SQGBT800" on the host product in such a location that it can be seen by an operator at the time of purchase.

User's Guide Requirements

The BT800 complies with FCC Part 15 Rules for a Modular Approval. To leverage Laird's grant, the conditions below must be met for the host device into which the BT800 is integrated:

1. The transmitter module is not co-located with any other transmitter or antenna that is capable of simultaneous operation.

As long as the conditions above are met, further transmitter testing is typically not required. However, the OEM integrator is still responsible for testing its end-product for any additional compliance requirements required with this module installed, such as (but not limited to) digital device emissions and PC peripheral requirements.

IMPORTANT!

In the event that the three conditions above cannot be met (for example certain device configurations or co-location with another transmitter), then the FCC authorization is no longer considered valid and the FCC ID cannot be used on the final product. In these circumstances, the OEM integrator will be responsible for re-evaluating the end product (including the transmitter) and obtaining a separate FCC authorization.

When using Laird's FCC grant for the BT800, the integrator must include specific information in the user's guide for the device into which the BT800 is integrated. The integrator must not provide information to the end user regarding how to install or remove this RF module in the user's manual of the device into which the BT800 is integrated. The following FCC statements must be added in their entirety and without modification into a prominent

Americas: +1-800-492-2320 Option 2

34

CONN-GUIDE-BT800_v0_2

Europe: +44-1628-858-940

Hong Kong: +852-2923-0610

www.lairdtech.com/bluetooth

place in the user's guide for the device into which the BT800 is integrated:

IMPORTANT NOTE: The product comply with the US/Canada portable RF exposure limit set forth for an uncontrolled environment and are safe for intended operation as described in this manual. The further RF exposure reduction can be achieved if the product can be kept as far as possible from the user body or set the device to lower output power if such function is available.

Federal Communication Commission Interference Statement

This equipment has been tested and found to comply with the limits for a Class B digital device, pursuant to Part 15 of the FCC Rules. These limits are designed to provide reasonable protection against harmful interference in a residential installation. This equipment generates, uses, and can radiate radio frequency energy and, if not installed and used in accordance with the instructions, may cause harmful interference to radio communications. However, there is no guarantee that interference will not occur in a particular installation. If this equipment does cause harmful interference to radio or television reception, which can be determined by turning the equipment off and on, the user is encouraged to try to correct the interference by one of the following measures:

1. Reorient or relocate the receiving antenna.
2. Increase the separation between the equipment and receiver.
3. Connect the equipment into an outlet on a circuit different from that to which the receiver is connected.
4. Consult the dealer or an experienced radio/TV technician for help.

FCC Caution: Any changes or modifications not expressly approved by the party responsible for compliance could void the user's authority to operate this equipment.

This device complies with Part 15 of the FCC Rules. Operation is subject to the following two conditions: (1) This device may not cause harmful interference, and (2) this device must accept any interference received, including interference that may cause undesired operation.

IMPORTANT NOTE: FCC Radiation Exposure Statement:

The product comply with the US/Canada portable RF exposure limit set forth for an uncontrolled environment and are safe for intended operation as described in this manual. The further RF exposure reduction can be achieved if the product can be kept as far as possible from the user body or set the device to lower output power if such function is available.

Industry Canada

Note: You must place "Contains IC: 3147A-BT800" on the host product in such a location that it can be seen by an operator at the time of purchase.

Radiation Exposure Statement:

Americas: +1-800-492-2320 Option 2
Europe: +44-1628-858-940
Hong Kong: +852-2923-0610
www.lairdtech.com/bluetooth

The product comply with the Canada portable RF exposure limit set forth for an uncontrolled environment and are safe for intended operation as described in this manual. The further RF exposure reduction can be achieved if the product can be kept as far as possible from the user body or set the device to lower output power if such function is available.

Déclaration d'exposition aux radiations:

Le produit est conforme aux limites d'exposition pour les appareils portables RF pour les Etats-Unis et le Canada établies pour un environnement non contrôlé.

Le produit est sûr pour un fonctionnement tel que décrit dans ce manuel. La réduction aux expositions RF peut être augmentée si l'appareil peut être conservé aussi loin que possible du corps de l'utilisateur ou que le dispositif est réglé sur la puissance de sortie la plus faible si une telle fonction est disponible.

PRELIMINARY

This radio transmitter (Contains IC: 3147A-BT800) has been approved by Industry Canada to operate with the antenna types listed in table above with the maximum permissible gain and required antenna impedance for each antenna type indicated. Antenna types not included in this list, having a gain greater than the maximum gain indicated for that type, are strictly prohibited for use with this device.

Le présent émetteur radio (Contient IC: 3147A-BT800) a été approuvé par Industrie Canada pour fonctionner avec les types d'antenne énumérés ci-dessous et ayant un gain admissible maximal et l'impédance requise pour chaque type d'antenne. Les types d'antenne non inclus dans cette liste, ou dont le gain est supérieur au gain maximal indiqué, sont strictement interdits pour l'exploitation de l'émetteur.

Under Industry Canada regulations, this radio transmitter may only operate using an antenna of a type and maximum (or lesser) gain approved for the transmitter by Industry Canada. To reduce potential radio interference to other users, the antenna type and its gain should be so chosen that the equivalent isotropically radiated power (e.i.r.p.) is not more than that necessary for successful communication.

Conformément à la réglementation d'Industrie Canada, le présent émetteur radio peut fonctionner avec une antenne d'un type et d'un gain maximal (ou inférieur) approuvé pour l'émetteur par Industrie Canada. Dans le but de réduire les risques de brouillage radioélectrique à l'intention des autres utilisateurs, il faut choisir le type d'antenne et son gain de sorte que la puissance isotrope rayonnée équivalente (p.i.r.e.) ne dépasse pas l'intensité nécessaire à l'établissement d'une communication satisfaisante.

This device complies with Industry Canada license-exempt RSS standard(s). Operation is subject to the following two conditions: (1) this device may not cause interference, and (2) this device must accept any interference, including interference that may cause undesired operation of the device.

Le présent appareil est conforme aux CNR d'Industrie Canada applicables aux appareils radio exempts de licence. L'exploitation est autorisée aux deux conditions suivantes : (1) l'appareil ne doit pas produire de brouillage, et (2) l'utilisateur de l'appareil doit accepter tout brouillage radioélectrique subi, même si le brouillage est susceptible d'en compromettre le fonctionnement.

16 EUROPEAN UNION REGULATORY

The BT800 has been tested for compliance with relevant standards for the EU market. BT800 module was tested with a 0.5 dBi chip antenna.

The OEM should consult with a qualified test house before entering their device into an EU member country to make sure all regulatory requirements have been met for their complete device.

Reference the Declaration of Conformities listed below for a full list of the standards that the modules were tested to. Test reports are available upon request.

17 EU DECLARATIONS OF CONFORMITY

17.1 BT800 / BT810 / BT820

Manufacturer:	Laird
Product:	BT800 / BT810 / BT820
EU Directive:	RTTE 1995/5/EC
Conformity Assessment:	Annex IV

Reference standards used for presumption of conformity:

Article Number	Requirement	Reference standard(s)
3.1a	Health and Safety	EN60950-1:2006+A11:2009+A1:2010+A12:2011 EN 301 489-1 V1.9.2 (2011-09) EN 301 489-17 V2.2.1 (2012-09)
3.1b	Protection requirements with respect to electromagnetic compatibility	Emissions: EN55022:2006/A1:2007 (Class B) Immunity: EN61000-4-2:2009 EN61000-4-3:2006/A1:2008/A2:2010
3.2	Means of the efficient use of the radio frequency spectrum	EN 300 328 V1.8.1 (2012-06)

Declaration:

We, Laird, declare under our sole responsibility that the essential radio test suites have been carried out and that the above product to which this declaration relates is in conformity with all the applicable essential requirements of Article 3 of the EU Directive 1999/5/EC, when used for its intended purpose.

Place of Issue:	Laird Saturn House, Mercury Park Wooburn Green HP100HH, United Kingdom tel: +44 (0)1628 858 940 fax: +44 (0)1628 528 382
Date of Issue:	July 2013
Name of Authorized Person:	Andrew Dobbing, Engineering Manager

Signature:



18 ORDERING INFORMATION

Part Number	Description
BT800	BTv4.0 Dual Mode USB HCI Module
BT810	BTv4.0 Dual Mode USB HCI Module (BlueGiga BT111 footprint)
BT820	BTv4.0 Dual Mode USB Dongle

18.1 General Comments

This is a preliminary datasheet. Please check with Laird for the latest information before commencing a design. If in doubt, ask.

PRELIMINARY

19 BLUETOOTH SIG APPROVALS

TBC

PRELIMINARY

Copyright © 2013 Laird Technologies, Inc. All rights reserved.

The information contained in this manual and the accompanying software programs are copyrighted and all rights are reserved by Laird Technologies, Inc. Laird Technologies, Inc. reserves the right to make periodic modifications of this product without obligation to notify any person or entity of such revision. Copying, duplicating, selling, or otherwise distributing any part of this product or accompanying documentation/software without the prior consent of an authorized representative of Laird Technologies, Inc. is strictly prohibited.

All brands and product names in this publication are registered trademarks or trademarks of their respective holders. This material is preliminary information furnished by Laird Technologies in this specification is believed to be accurate. Devices sold by Laird Technologies are covered by the warranty and patent indemnification provisions appearing in its Terms of Sale only. Laird Technologies makes no warranty, express, statutory, and implied or by description, regarding the information set forth herein. Laird Technologies reserves the right to change specifications at any time and without notice. Laird Technologies' products are intended for use in normal commercial and industrial applications. Applications requiring unusual environmental requirements such as military, medical life-support or life-sustaining equipment are specifically not recommended without additional testing for such application. Limited Warranty, Disclaimer, Limitation of Liability