



FCC 47 CFR PART 15 SUBPART C

TEST REPORT

For

Applicant : Honey Bee (Hong Kong) Ltd.

Address : Flat L,12/F,Phase 4, Kwun Tong Industrial Centre, 436-446 Kwun Tong Road,Kowloon, Hong Kong

Product Name : VitaSound Personal Audio Enhancer

Model Name : PAE-300

Brand Name : VitaSound

FCC ID : S9X-PAE-300-2

Report No. : MTE/DAL/T13050567

Date of Issue : May 18, 2013

Issued by : Most Technology Service Co., Ltd.

Address : No.5, Langshan 2nd Rd., North Hi-Tech Industrial park, Nanshan, Shenzhen, Guangdong, China

Tel : 86-755-8617 0306

Fax : 86-755-8617 0310

The report consists 41 pages in total. It may be duplicated completely for legal use with the approval of the applicant. It should not be reproduced except in full, without the written approval of our laboratory. The client should not use it to claim product endorsement by MOST. The test results in the report only apply to the tested sample. The test report shall be invalid without all the signatures of testing engineers, reviewer and approver.

TABLE OF CONTENTS

- 1. VERIFICATION OF CONFORMITY..... 3**
- 2. GENERAL INFORMATION..... 4**
 - 2.1 Product Information..... 4
 - 2.2 Objective..... 5
 - 2.3 Test Standards and Results..... 5
 - 2.4 Environmental Conditions..... 5
- 3. TEST FACILITY..... 6**
- 4. TEST EQUIPMENT LIST..... 8**
- 5. 47 CFR Part 15 C 15.247 Requirements..... 10**
 - 5.1 6dB Bandwidth..... 10**
 - 5.1.1 Definition..... 10
 - 5.1.2 Test Description..... 10
 - 5.1.3 Test Result..... 10
 - 5.2 Peak Output Power..... 13**
 - 5.2.1 Definition..... 13
 - 5.2.2 Test Description..... 13
 - 5.2.3 Test Result..... 13
 - 5.3 Conducted Spurious Emission..... 15**
 - 5.3.1 Definition..... 15
 - 5.3.2 Test Description..... 15
 - 5.3.3 Test Result..... 15
 - 5.4 Band Edge..... 15**
 - 5.4.1 Definition..... 18
 - 5.4.2 Test Description..... 18
 - 5.4.3 Test Result..... 19
 - 5.5 Power Spectral Density (PSD)..... 24**
 - 5.5.1 Definition..... 24
 - 5.5.2 Test Description..... 24
 - 5.5.3 Test Result..... 24
 - 5.6 Conducted Emission..... 26**
 - 5.6.1 Definition..... 26
 - 5.6.2 Test Description..... 26
 - 5.6.3 Test Result..... 27
 - 5.7 Radiated Emission..... 29**
 - 5.7.1 Definition..... 29
 - 5.7.2 Test Description..... 30
 - 5.7.3 Test Result..... 32
- APPENDIX 1 PHOTOGRAPHS OF TEST SETUP..... 37**

1. VERIFICATION OF CONFORMITY

Equipment Under Test: VitaSound Personal Audio Enhancer
Brand Name: VitaSound
Model Number: PAE-300
Series Model Name: N/A
Difference description: N/A
FCC ID: S9X-PAE-300-2
Applicant: Honey Bee (Hong Kong) Ltd.
 Flat L,12/F,Phase 4, Kwun Tong Industrial Centre, 436-446 Kwun Tong Road,Kowloon, Hong Kong
Manufacturer: Honey Bee (Hong Kong) Ltd.
 Flat L,12/F,Phase 4, Kwun Tong Industrial Centre, 436-446 Kwun Tong Road,Kowloon, Hong Kong
Technical Standards: 47 CFR Part 15 Subpart C, KDB558074
File Number: MTE/DAL/T13050567
Date of test: April 23,2013~ May 18, 2013
Deviation: None
Condition of Test Sample: Normal
Test Result: PASS

The above equipment was tested by MOST for compliance with the requirements set forth in FCC rules and the Technical Standards mentioned above. This said equipment in the configuration described in this report shows the maximum emission levels emanating from equipment and the level of the immunity endurance of the equipment are within the compliance requirements.

The test results of this report relate only to the tested sample identified in this report.

Tested by (+ signature): 
 Zhang Ling May 18, 2013

Review by (+ signature): 
 July Wen May 18, 2013

Approved by (+ signature): 
 Terry Yang May 18, 2013

2. GENERAL INFORMATION

2.1 Product Information

Product	VitaSound Personal Audio Enhancer
Trade Name	VitaSound
Model Number	PAE-300
Series Number:	N/A
Description of Differences:	N/A
Power Supply	DC 9.0V by Adapter (Input:100-240V,50/60 Hz,600mA, Output:9.0V,2.0A)
Frequency Range	2403MHz -2477MHz
Modulation Type	FHSS
Antenna Type:	1.0 dBi, PCB Antenna
Channel Number	74(CH Low: 2403MHz, CH Mid: 2440MHz, CH High: 2477MHz)
Temperature Range	0°C ~ 35°C

NOTE:

1. For a more detailed features description about the EUT, please refer to User's Manual.

2.2 Objective

The objective of the report is to perform tests according to 47 CFR Part 15 Subpart C for the EUT FCC ID Certification:

No.	Identity	Document Title
1	47 CFR Part 15(10-1-11 Edition)	Radio Frequency Devices

2.3 Test Standards and Results

Test items and the results are as bellow:

No.	Section	Description	Result	Date of Test
1	15.247(a)(2)	6dB Bandwidth	PASS	2013-05-18
2	15.247(b)(3)	Peak Output Power	PASS	2013-05-18
3	15.247(d)	Conducted Spurious Emission	PASS	2013-05-18
4	15.247(d)	Band Edge	PASS	2013-05-18
5	15.247(e)	Power Spectral Density	PASS	2013-05-18
6	15.207	Conducted Emission	PASS	2013-05-13
7	15.247(d) 15.205 15.209	Radiated Emission	PASS	2013-05-13

Note:

1. The test result judgment is decided by the limit of measurement standard
2. The information of measurement uncertainty is available upon the customer's request.
3. The method of measurement is refer to FCC KDB558074 (Measurement of Digital Transmission Systems Operating under Section 15.247 March 23, 2005).

2.4 Environmental Conditions

During the measurement the environmental conditions were within the listed ranges:

- Temperature: 15-35°C
- Humidity: 30-60 %
- Atmospheric pressure: 86-106 kPa

3. TEST FACILITY

3.1 TEST FACILITY

Test Site:	Most Technology Service Co., Ltd.
Location:	No.5, Langshan 2nd Rd, North Hi-Tech Industrial park, Nanshan, Shenzhen, Guangdong, China
Description:	<p>There is one 3m semi-anechoic an area test sites and two line conducted labs for final test. The Open Area Test Sites and the Line Conducted labs are constructed and calibrated to meet the FCC requirements in documents ANSI C63.4:2009 and CISPR 16 requirements.</p> <p>The FCC Registration Number is 490827.</p> <p>The IC Registration Number is 7103A-1.</p> <p>The CNAS Registration Number is CNAS L3573.</p>
Site Filing:	The site description is on file with the Federal Communications Commission, 7435 Oakland Mills Road, Columbia, MD 21046.
Instrument Tolerance:	All measuring equipment is in accord with ANSI C63.4:2009 and CISPR 16 requirements that meet industry regulatory agency and accreditation agency requirement.
Ground Plane:	Two conductive reference ground planes were used during the Line Conducted Emission, one in vertical and the other in horizontal. The dimensions of these ground planes are as below. The vertical ground plane was placed distancing 40 cm to the rear of the wooden test table on where the EUT and the support equipment were placed during test. The horizontal ground plane projected 50 cm beyond the footprint of the EUT system and distanced 80 cm to the wooden test table. For Radiated Emission Test, one horizontal conductive ground plane extended at least 1m beyond the periphery of the EUT and the largest measuring antenna, and covered the entire area between the EUT and the antenna. It has no holes or gaps having longitudinal dimensions larger than one-tenth of a wavelength at the highest frequency of measurement up to 1GHz.

3.2 GENERAL TEST PROCEDURES

EUT Function and Test Mode

The EUT has been tested under normal operating (TX) and standby (RX) condition.

The field strength of radiation emission was measured in the following position: EUT stand-up position (Y axis).

The following data show only with the worst case setup.

The worst case was reported.

Based on client request, all normal using modes of the normal function were tested but only the worst test data of the worst mode is reported by this report.

Conducted Emissions

The EUT is placed on the turntable, which is 0.8 m above ground plane. According to the requirements in Section 13.1.4.1 of ANSI C63.4:2009,Conducted emissions from the EUT measured in the frequency range between 0.15 MHz and 30MHz using CISPR Quasi-peak and average detector modes.

Radiated Emissions

The EUT is placed on a turn table, which is 0.8 m above ground plane. The turntable shall rotate 360 degrees to determine the position of maximum emission level. EUT is set 3m away from the receiving antenna, which varied from 1m to 4m to find out the highest emission. And also, each emission was to be maximized by changing the polarization of receiving antenna both horizontal and vertical. In order to find out the maximum emissions, exploratory radiated emission measurements were made according to the requirements in Section 13.1.4.1 of ANSI C63.4:2009.

3.3 FCC PART 15.205 RESTRICTED BANDS OF OPERATIONS

(a) Except as shown in paragraph (d) of this section, only spurious emissions are permitted in any of the frequency bands listed below:

MHz	MHz	MHz	GHz
0.090 0.110	16.42 - 16.423	399.9 - 410	4.5 - 5.15
¹ 0.495 0.505	16.69475 - 16.69525	608 - 614	5.35 - 5.46
2.1735 2.1905	16.80425 - 16.80475	960 - 1240	7.25 - 7.75
4.125 - 4.128	25.5 - 25.67	1300 - 1427	8.025 - 8.5
4.17725 - 4.17775	37.5 - 38.25	1435 - 1626.5	9.0 - 9.2
4.20725 - 4.20775	73 - 74.6	1645.5 - 1646.5	9.3 - 9.5
6.215 - 6.218	74.8 - 75.2	1660 - 1710	10.6 - 12.7
6.26775 - 6.26825	108 - 121.94	1718.8 - 1722.2	13.25 - 13.4
6.31175 - 6.31225	123 - 138	2200 - 2300	14.47 - 14.5
8.291 - 8.294	149.9 - 150.05	2310 - 2390	15.35 - 16.2
8.362 8.366	156.52475 - 156.52525	2483.5 - 2500	17.7 - 21.4
8.37625 - 8.38675	156.7 - 156.9	2655 - 2900	22.01 - 23.12
8.41425 - 8.41475	162.0125 - 167.17	3260 - 3267	23.6 - 24.0
12.29 - 12.293	167.72 - 173.2	3332 - 3339	31.2 - 31.8
12.51975 - 12.52025	240 - 285	3345.8 - 3358	36.43 - 36.5
12.57675 - 12.57725	322 - 335.4	3600 - 4400	(²)
13.36 13.41			

¹ Until February 1, 1999, this restricted band shall be 0.490-0.510 MHz.

² Above 38.6

(b) Except as provided in paragraphs (d) and (e), the field strength of emissions appearing within these frequency bands shall not exceed the limits shown in Section 15.209. At frequencies equal to or less than 1000 MHz, compliance with the limits in Section 15.209 shall be demonstrated using measurement instrumentation employing a CISPR quasi-peak detector. Above 1000 MHz, compliance with the emission limits in Section 15.209 shall be demonstrated based on the average value of the measured emissions. The provisions in Section 15.35 apply to these measurements

4. SETUP OF TEST EQUIPMENT LIST

4.1 SUPPORT EQUIPMENT

Device Type	Manufacturer	Model Name	Serial No.	Data Cable	Power Cable
IPOD	APPLE	A1367	C3TG76Q3DCP7		N/A
POWER ADAPTOR	UE	UE24WU-090200SPA	N/A		2.0-Shield
EARPHONE	SONY	N/A	N/A		N/A
Personal Audio Enhancer (Receiver)	Honeybee	HB-1101	N/A		N/A

Remark:

All the equipment/cables were placed in the worst-case configuration to maximize the emission during the test. Grounding was established in accordance with the manufacturer's requirements and conditions for the intended use.

4.2 TEST EQUIPMENT LIST

Instrumentation: The following list contains equipment used at MOST for testing. The equipment conforms to the CISPR 16-1/ANSI C63.2 Specifications for Electromagnetic Interference and Field Strength Instrumentation from 10 kHz to 1.0 GHz or above.

No.	Equipment	Manufacturer	Model No.	S/N	Calibration date	Calibration due date
1	Test Receiver	Rohde & Schwarz	ESCI	100492	2013/03/14	2014/03/14
2	L.I.S.N.	Rohde & Schwarz	ENV216	100093	2013/03/14	2014/03/14
3	Coaxial Switch	Anritsu Corp	MP59B	6200283933	2013/03/14	2014/03/14
4	Terminator	Hubersuhner	50Ω	No.1	2013/03/14	2014/03/14
5	RF Cable	SchwarzBeck	N/A	No.1	2013/03/14	2014/03/14
6	Test Receiver	Rohde & Schwarz	ESPI	101202	2013/03/14	2014/03/14
7	Bilog Antenna	Sunol	JB3	A121206	2013/03/14	2014/03/14
8	Test Antenna - Horn	Schwarzbeck	BBHA 9120C	--	2013/03/14	2014/03/14
9	Test Antenna - Horn	Schwarzbeck	BBHA 9170	--	2013/03/14	2014/03/14
10	Test Antenna - LOOP	Schwarzbeck	HFRA 5149	--	2013/03/14	2014/03/14
11	Cable	SchwarzBeck	N/A	NO.1	2013/03/14	2014/03/14
12	Cable	SchwarzBeck	N/A	NO.2	2013/03/14	2014/03/14
13	DC Power Filter	DuoJi	DL2730B	N/A	2013/03/14	2014/03/14
14	Single Phase Power Line Filter	DuoJi	FNF 202B30	N/A	2013/03/14	2014/03/14
15	3 Phase Power Line Filter	DuoJi	FNF 402B30	N/A	2013/03/14	2014/03/14
16	Spectrum Analyzer	Agilent	4408B	MY41440460	2013/03/14	2014/03/14
17	Absorbing Clamp	Luthi	MDS21	3635	2013/03/14	2014/03/14
18	Coaxial Switch	Anritsu Corp	MP59B	6200283933	2013/03/14	2014/03/14
19	AC Power Source	Kikusui	AC40MA	LM003232	2013/03/14	2014/03/14
20	Test Analyzer	Kikusui	KHA1000	LM003720	2013/03/14	2014/03/14
21	Line Impedance Network	Kikusui	LIN40MA-PCR-L	LM002352	2013/03/14	2014/03/14
22	ESD Tester	Kikusui	KES4021	LM003537	2013/03/14	2014/03/14
23	EMC PRO System	EM Test	UCS-500-M4	V0648102026	2013/03/14	2014/03/14
24	Signal Generator	IFR	2032	203002/100	2013/03/14	2014/03/14
25	Amplifier	A&R	150W1000	301584	2013/03/14	2014/03/14
26	CDN	FCC	FCC-801-M2-25	47	2013/03/14	2014/03/14
27	CDN	FCC	FCC-801-M3-25	107	2013/03/14	2014/03/14
28	EM Injection Clamp	FCC	F-203I-23mm	403	2013/03/14	2014/03/14
29	RF Cable	MIYAZAKI	N/A	No.1/No.2	2013/03/14	2014/03/14
30	Universal Radio Communication Tester	ROHDE&SCHWARZ	CMU200	0304789	2013/03/14	2014/03/14
31	Telecommunication Antenna	European Antennas	PSA 75301R/170	0304213	2013/03/14	2014/03/14
32	Temperature Chamber	Guangzhou Gongwen	GDS-250	N/A	2013/03/14	2014/03/14

NOTE: Equipments listed above have been calibrated and are in the period of validation.

5. 47 CFR Part 15 C 15.247 Requirements

5.1 6dB Bandwidth

5.1.1 Definition

Systems using digital modulation techniques may operate in the 902–928 MHz, 2400–2483.5 MHz, and 5725–5850 MHz bands. The minimum 6 dB bandwidth shall be at least 500 kHz.

5.1.2 Test Description

The EUT is powered by the Battery, is coupled to the Spectrum Analyzer (SA) through the Attenuator/DC Block. The path loss as the factor is calibrated to correct the reading. During the measurement, the EUT is activated and is set to operate at maximum power. The RF load attached to the EUT antenna terminal is 50Ohm.

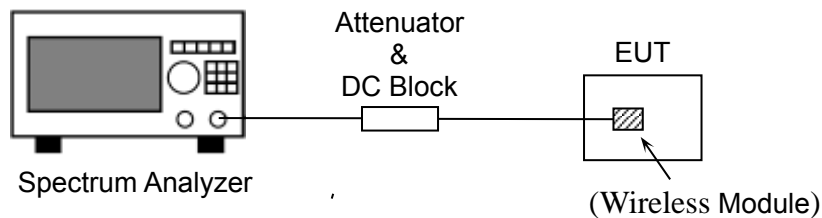
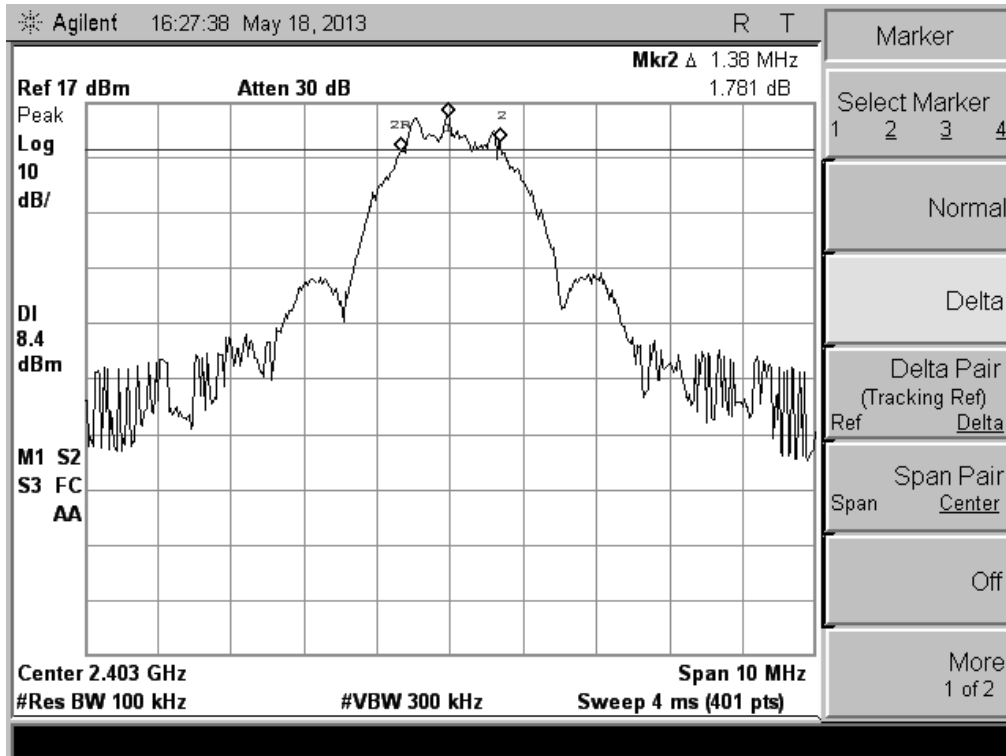

Figure 1: RF Test Setup

5.1.3 Test Result

The lowest, middle and highest channels are selected to perform testing to record the 6 dB bandwidth of the Module.

Channel	Frequency (MHz)	6 dB Bandwidth (MHz)	Limits (kHz)	Result
Low	2403	1.38	≥500	PASS
Mid	2440	1.48	≥500	PASS
High	2477	1.55	≥500	PASS



(CH Low)

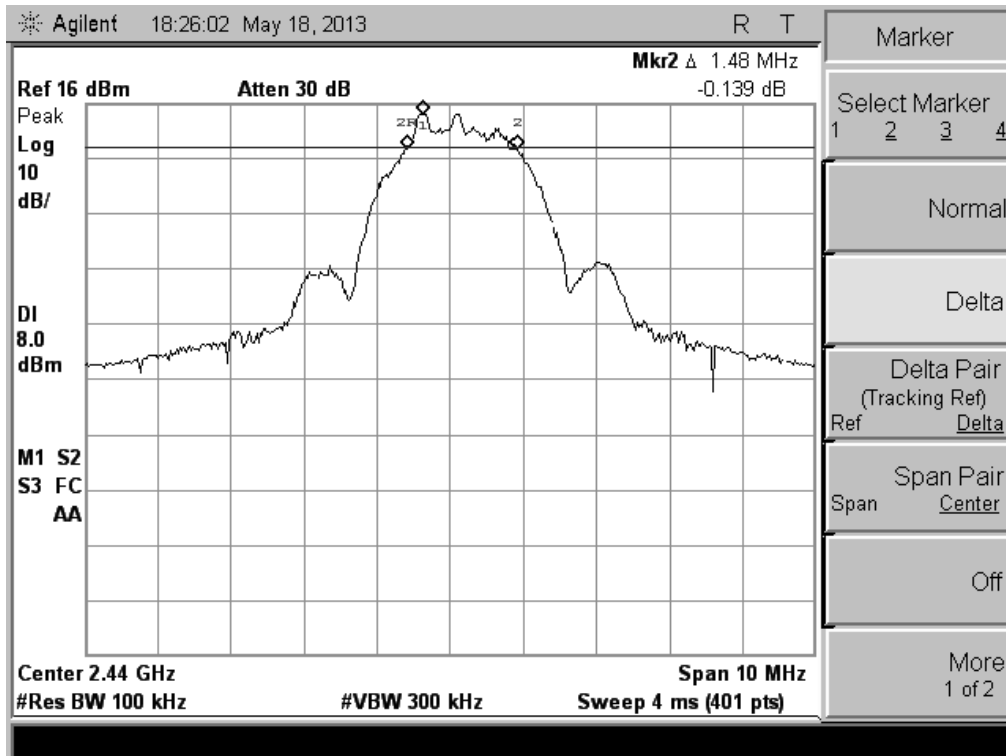

(CH Mid)

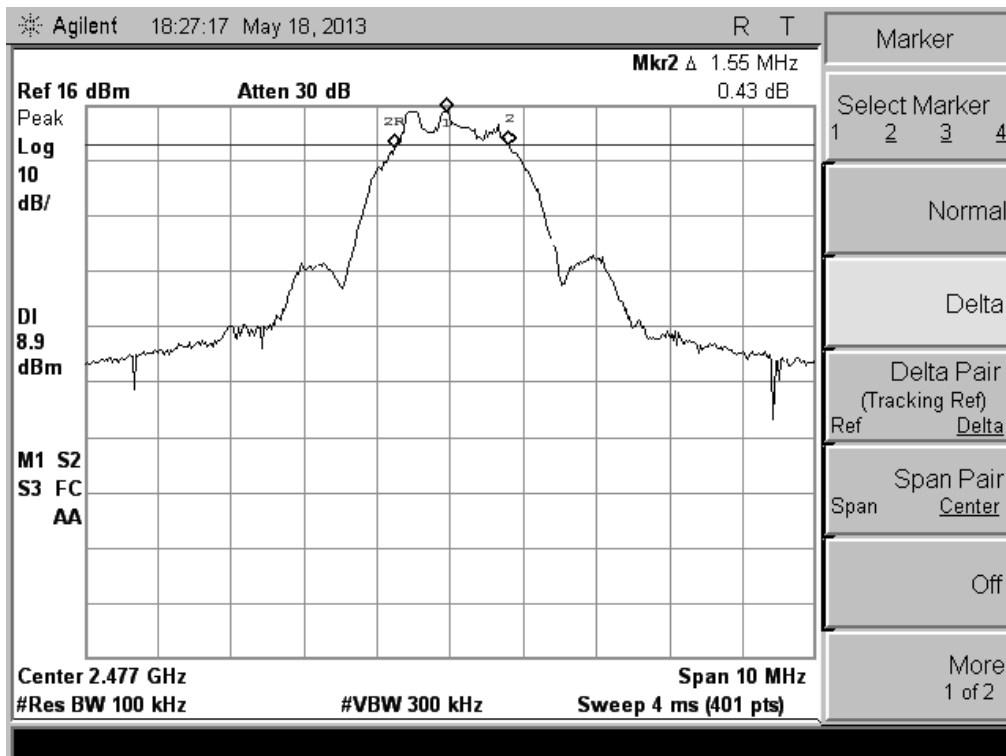

(CH High)

5.2 Peak Output Power

5.2.1 Definition

For systems using digital modulation in the 902–928 MHz, 2400–2483.5 MHz, and 5725–5850 MHz bands: 1 Watt. As an alternative to a peak power measurement, compliance with the one Watt limit can be based on a measurement of the maximum conducted output power.

5.2.2 Test Description

See section 5.1.2 of this report.

5.2.3 Test Result

The EUT operates at maximum output power mode. The lowest, middle and highest channels are selected to perform testing to verify the conducted RF output peak power of the Module.

Channel	Frequency (MHz)	Measured Output Peak Power		Limit		Verdict
		dBm	mW	dBm	mW	
Low	2403	12.04	15.996	30	1000	PASS
Mid	2440	13.79	23.933			PASS
High	2477	13.83	24.155			PASS

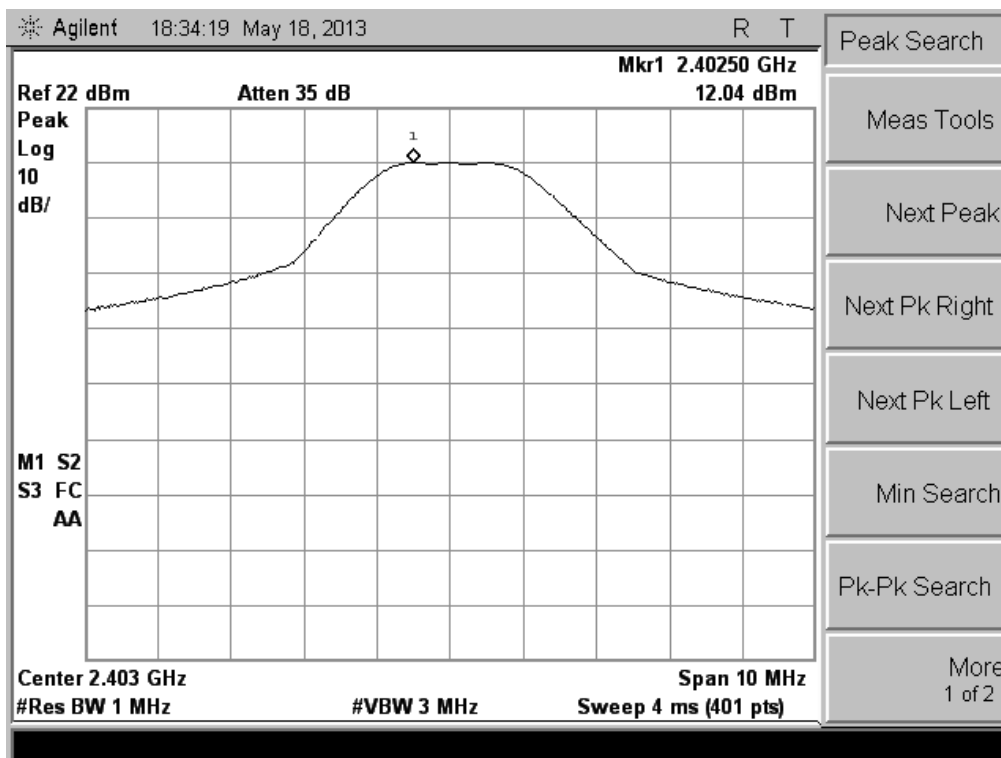

(CH Low)

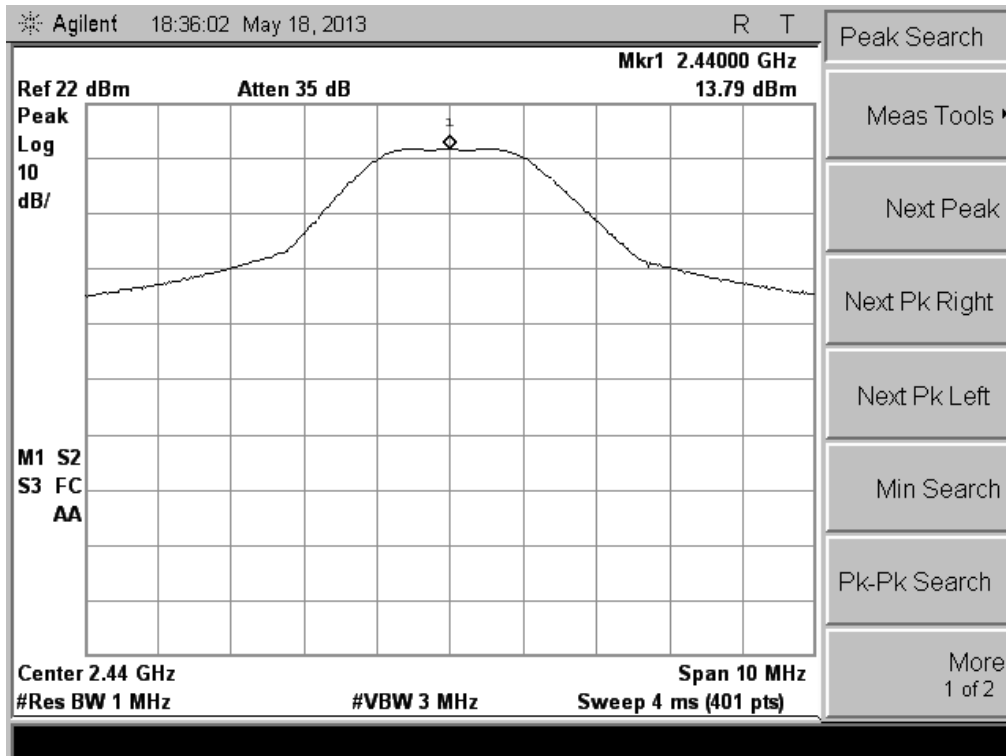

(CH Mid)

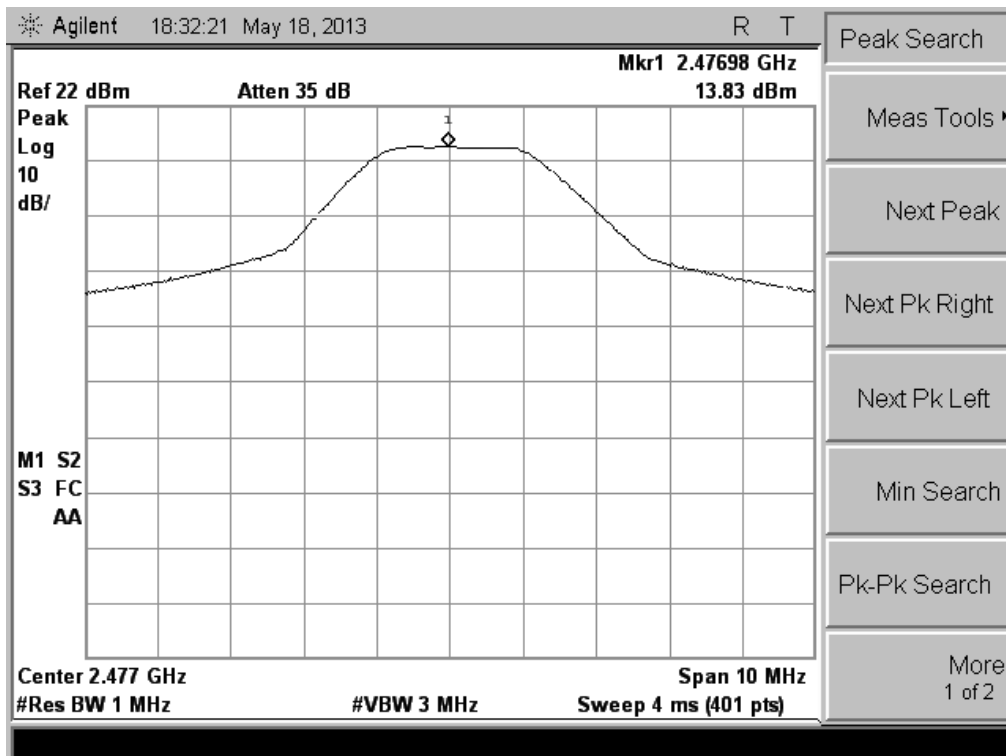

(CH High)

5.3 Conducted Spurious Emission

5.3.1 Definition

In any 100 kHz bandwidth outside the frequency band in which the spread spectrum or digitally modulated intentional radiator is operating, the radio frequency power that is produced by the intentional radiator shall be at least 20 dB below that in the 100 kHz bandwidth within the band that contains the highest level of the desired power, based on either an RF conducted or a radiated measurement, provided the transmitter demonstrates compliance with the peak conducted power limits.

5.3.2 Test Description

See section 5.1.2 of this report.

5.3.3 Test Result

1. Table for the Harmonics:

No.	Frequency (MHz)	RBW (KHz)	VBW (KHz)	Emission Power (dBm)	Limit (dBm)
Low Channel (2403MHz)					
Form 9KHz to 150KHz					
1	--	1	10	---	-13
Form 150KHz to 30MHz					
2	--	10	30	---	-13
Form 30MHz to 1000MHz					
3	--	100	300	---	-13
Above 1000MHz					
4	4806.60	1000	3000	-30.00	-13
5	--	1000	3000	---	-13
6	--	1000	3000	---	-13
Middle Channel (2440MHz)					
Form 9KHz to 150KHz					
7	--	1	10	--	-13
Form 150KHz to 30MHz					
8	--	10	30	---	-13
Form 30MHz to 1000MHz					
9	--	100	300	---	-13
Above 1000MHz					
10	1760.10	1000	3000	-25.33	-13
11	4880.20	1000	3000	-28.54	-13
12	--	1000	3000	---	
High Channel (2477MHz)					
Form 9KHz to 150KHz					
13	--	1	10	---	-13
Form 150KHz to 30MHz					
14	--	10	30	---	-13
Form 30MHz to 1000MHz					
15	--	100	300	---	-13
Above 1000MHz					
16	4940.40	1000	3000	-25.12	-13
17	--	1000	3000	---	-13

Note: “---” in the table above means that the emissions are too small to be measured and are at least 10 dB below the limit.

2. Plot for Spurious Emission:

The measuring frequency range was from 9 kHz to 10GHz, but only the worst (above 1000MHz band) test plots were display as below.

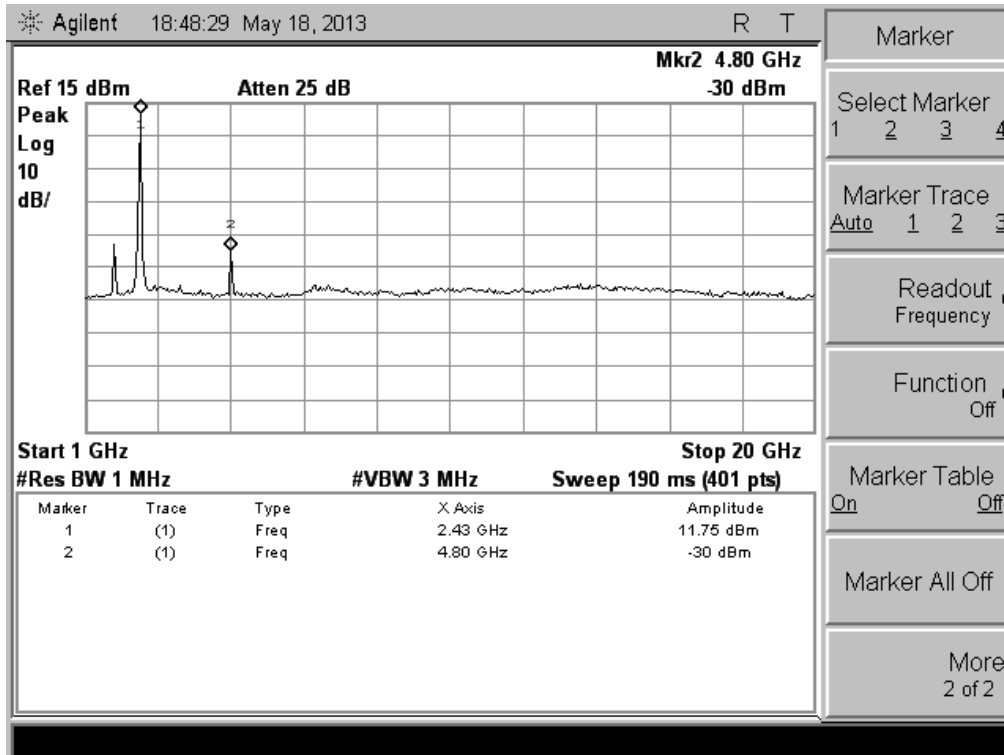

(Low Channel)

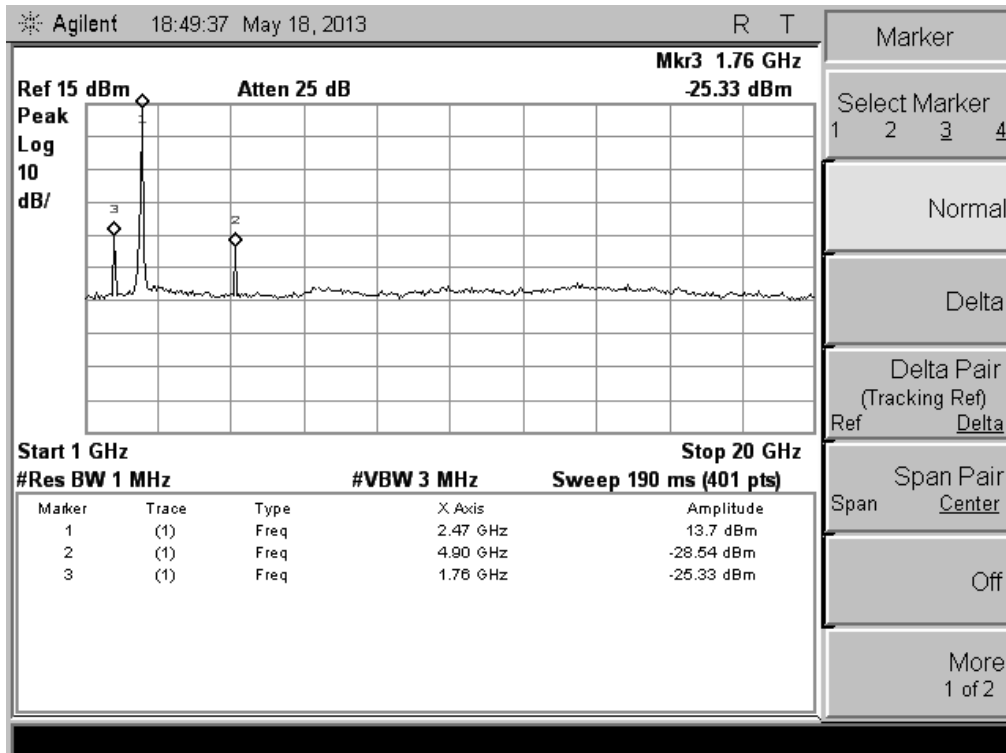

(Middle Channel)

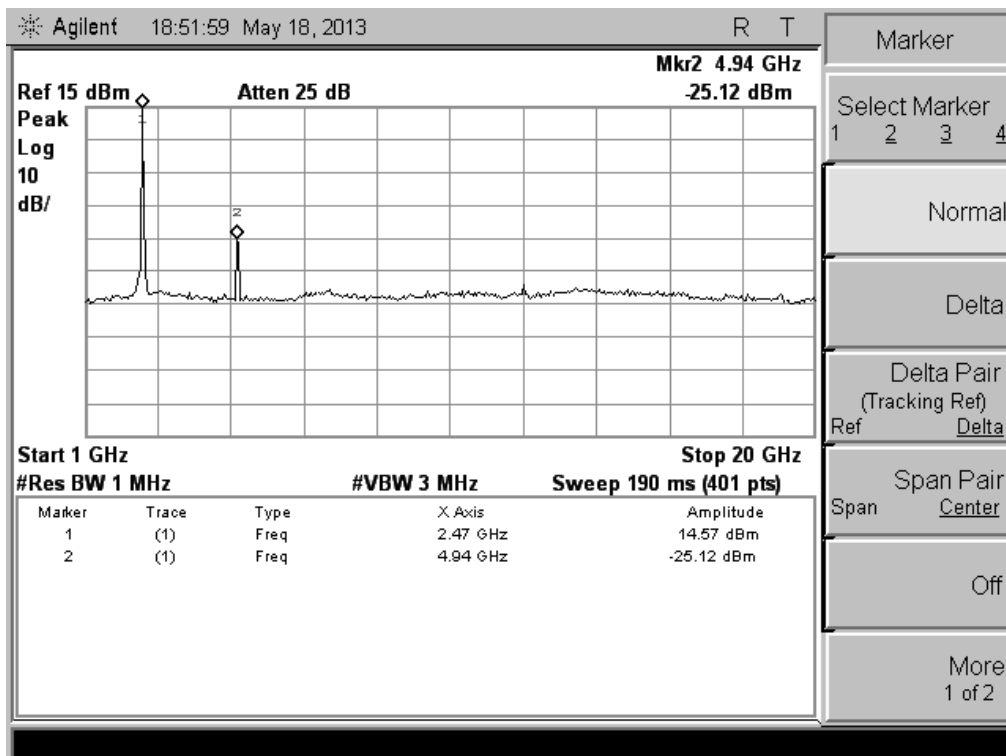

(High Channel)

5.4 Band Edge

5.4.1 Definition

In any 100 kHz bandwidth outside the frequency band in which the spread spectrum or digitally modulated intentional radiator is operating, the radio frequency power that is produced by the intentional radiator shall be at least 20 dB below that in the 100 kHz bandwidth within the band that contains the highest level of the desired power, based on either an RF conducted or a radiated measurement, provided the transmitter demonstrates compliance with the peak conducted power limits.

5.4.2 Test Description

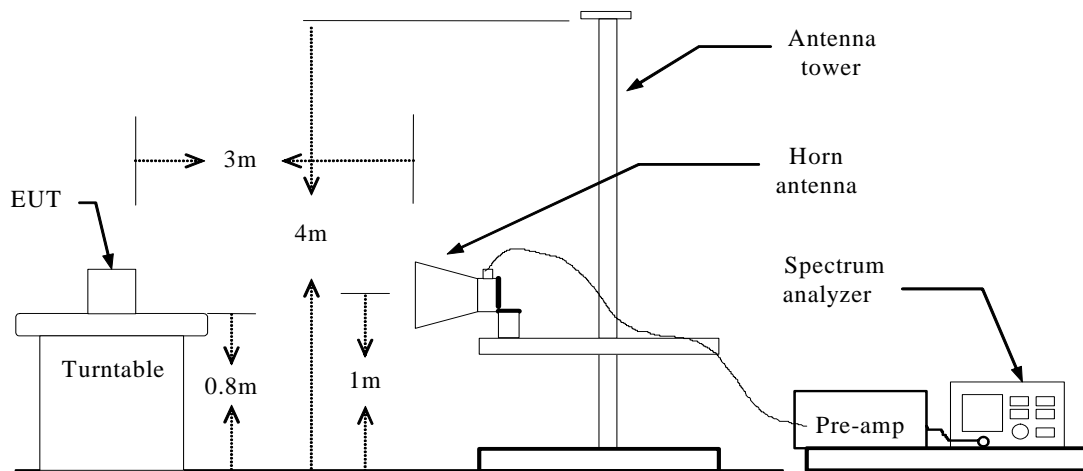

5.4.3 Test Result

The EUT operates at continuous transmit test mode. The peak and average test data of the lowest and highest channels are tested to verify the band edge emissions.

Test Mode		Channel Marked Frequency	Limit (dBuV/m)	Test Result Highest Emission (dBuV/m)			
				Vertical		Horizontal	
				Peak	Average	Peak	Average
Transmitting	Low Channel	2390MHz	74(Peak) 54(Average)	71.42	48.23	72.14	48.92
	High Channel	2483.5MHz		73.09	45.57	73.21	45.80

Test Plot:

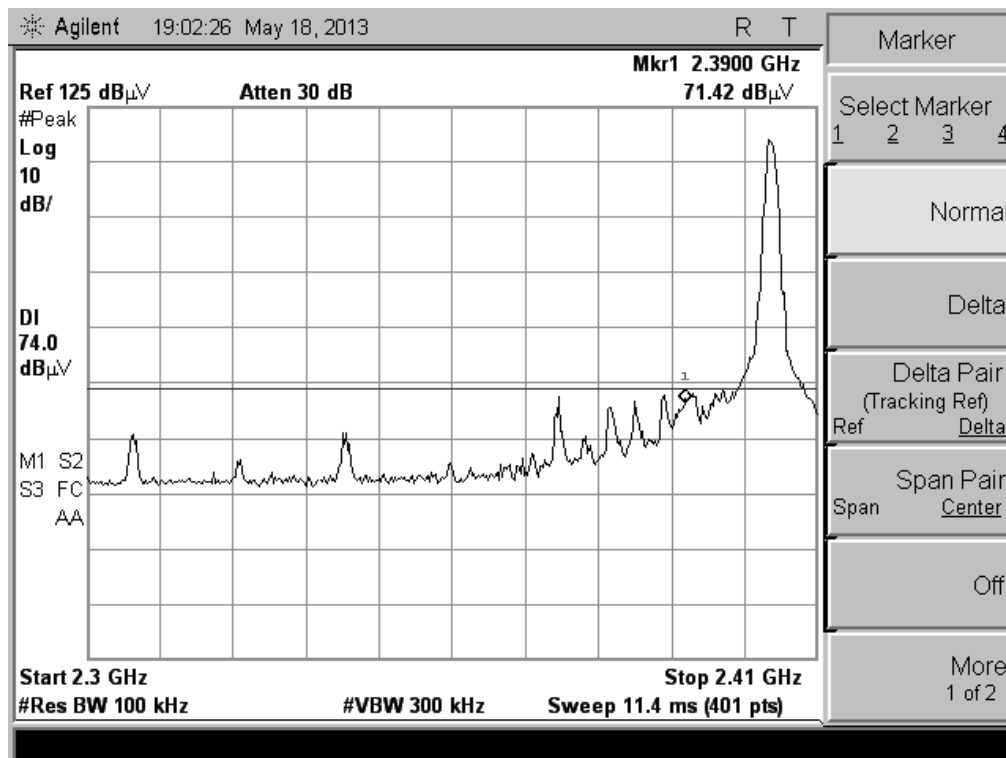

(CH Low, Vertical, Peak)

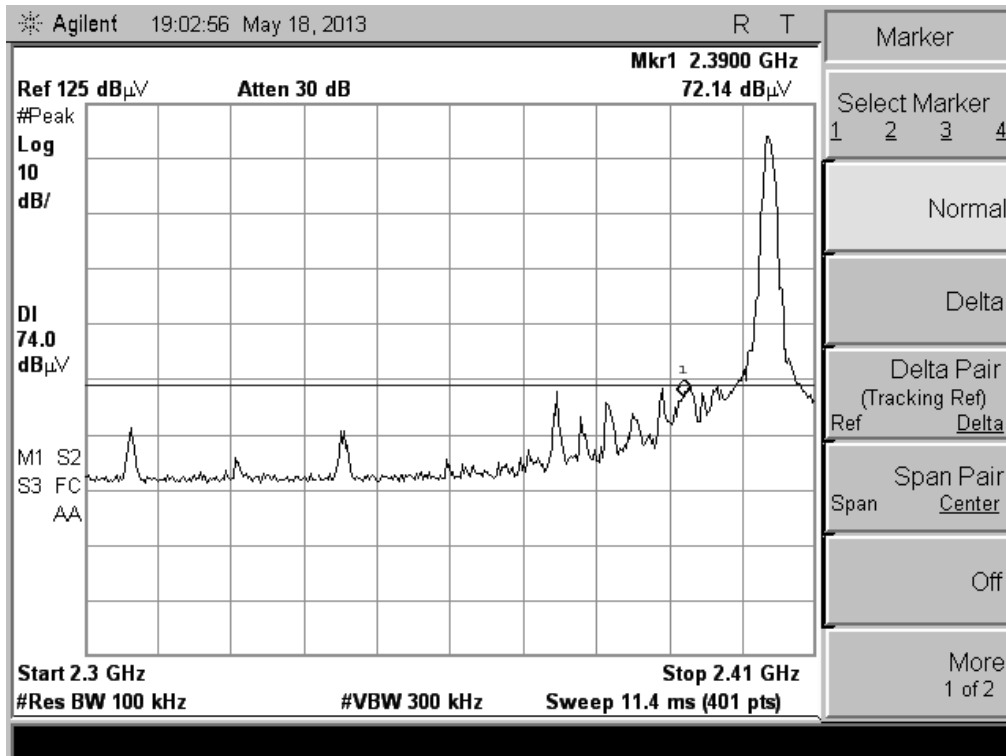

(CH Low, Horizontal, Peak)

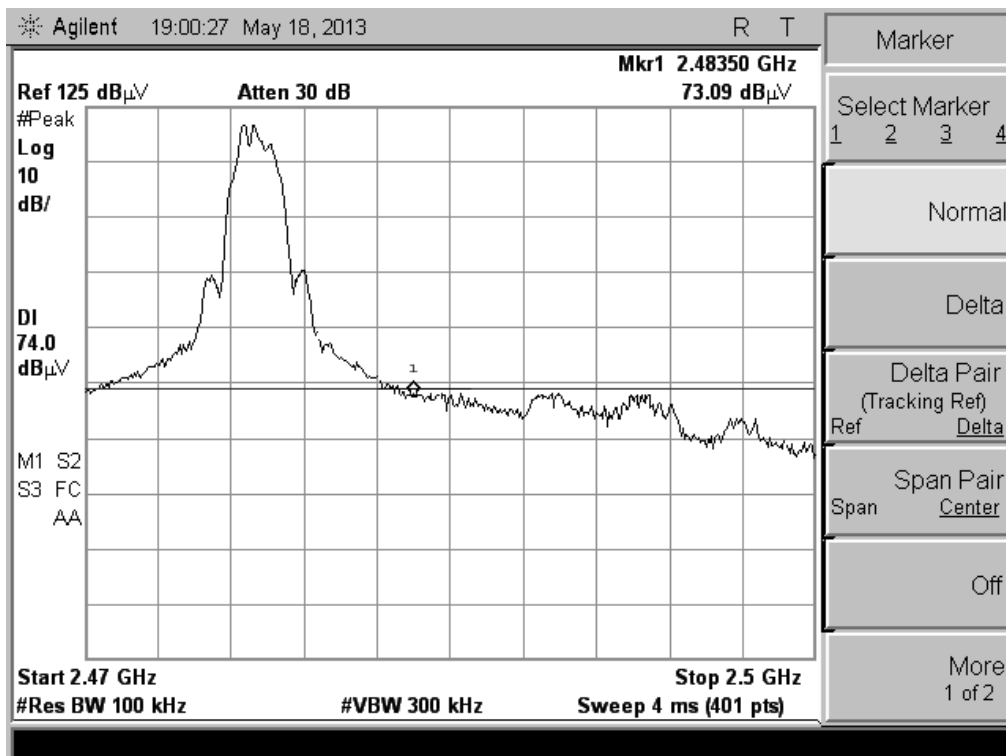

(CH High, Vertical, Peak)

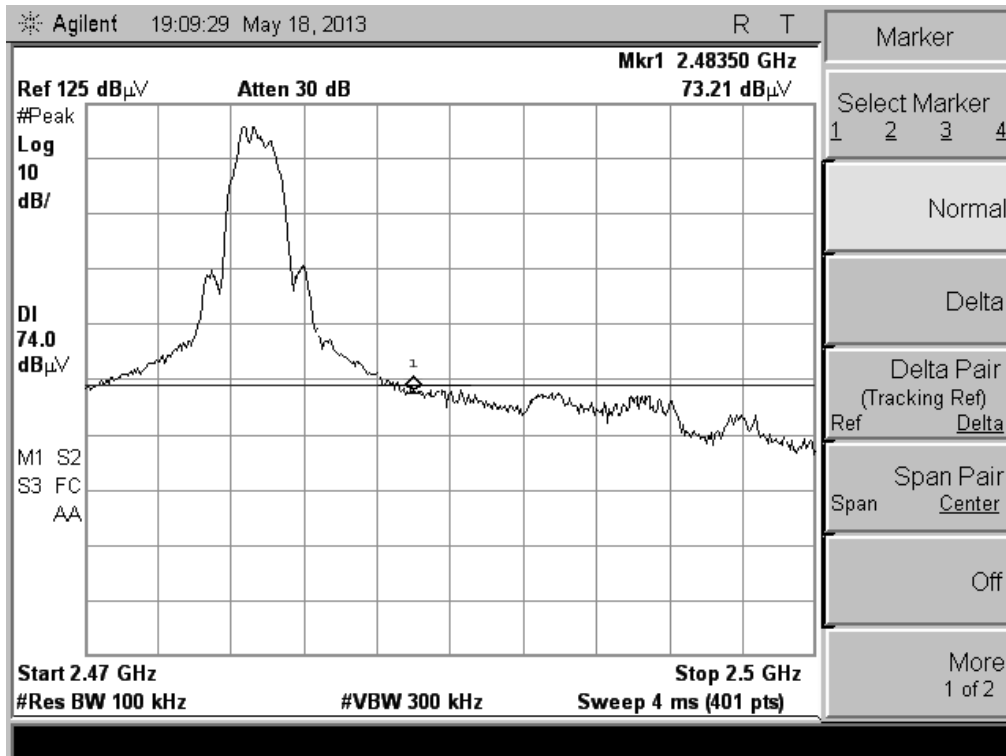

(CH High, Horizontal, Peak)

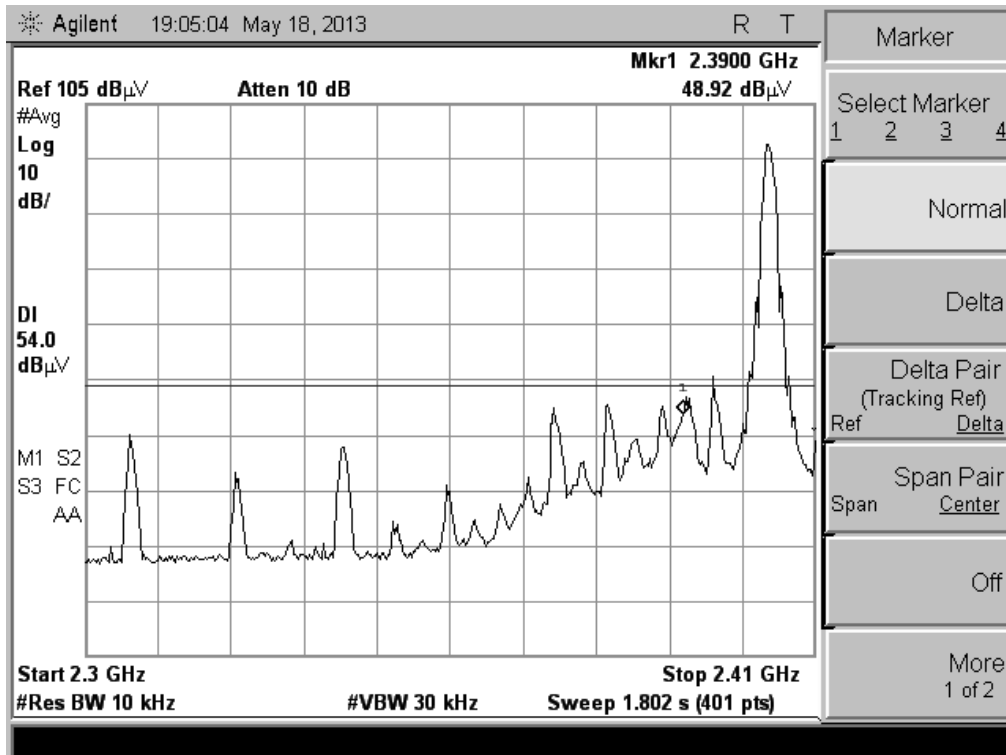

(CH Low, Horizontal, Average)

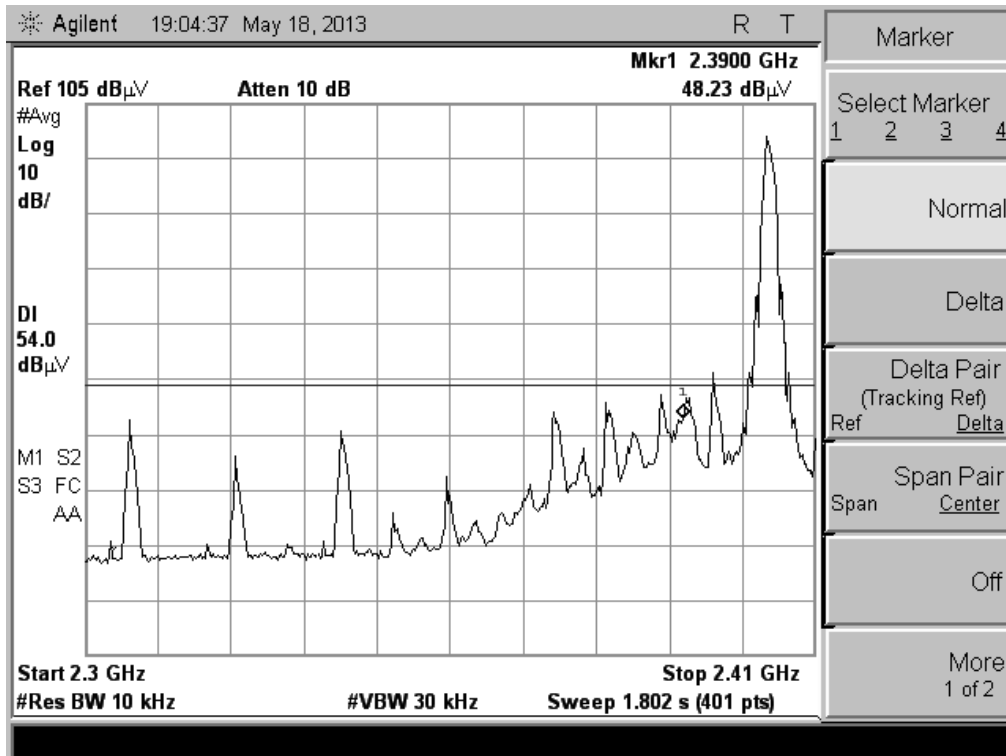

(CH Low, Vertical, Average)



(CH High, Vertical, Average)

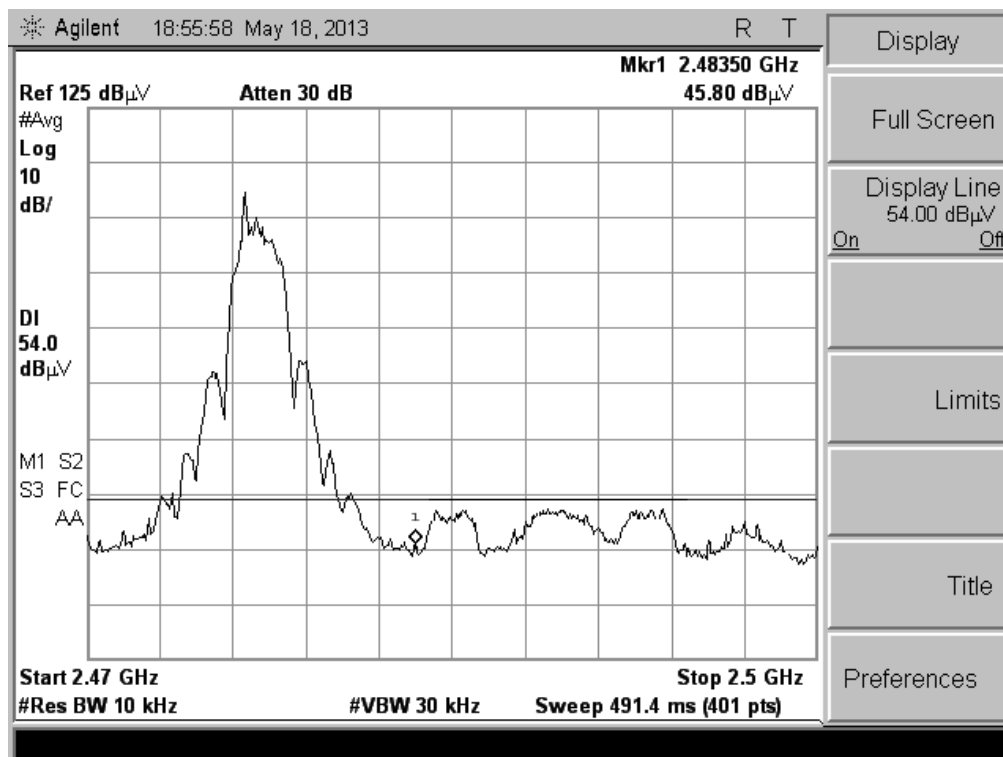

(CH High,Horizontal, Average)

5.5 Power Spectral Density (PSD)

5.5.1 Definition

For digitally modulated systems, the power spectral density conducted from the intentional radiator to the antenna shall not be greater than 8 dBm in any 3 kHz band during any time interval of continuous transmission.

5.5.2 Test Description

See section 5.1.2 of this report.

5.5.3 Test Result

The lowest, middle and highest channels are tested to verify the power spectral density.

Channel	Frequency (MHz)	PSD (dBm)	Limits(dBm)	Result
Low	2403	5.461	≤8	PASS
Mid	2440	4.779	≤8	PASS
High	2477	5.735	≤8	PASS

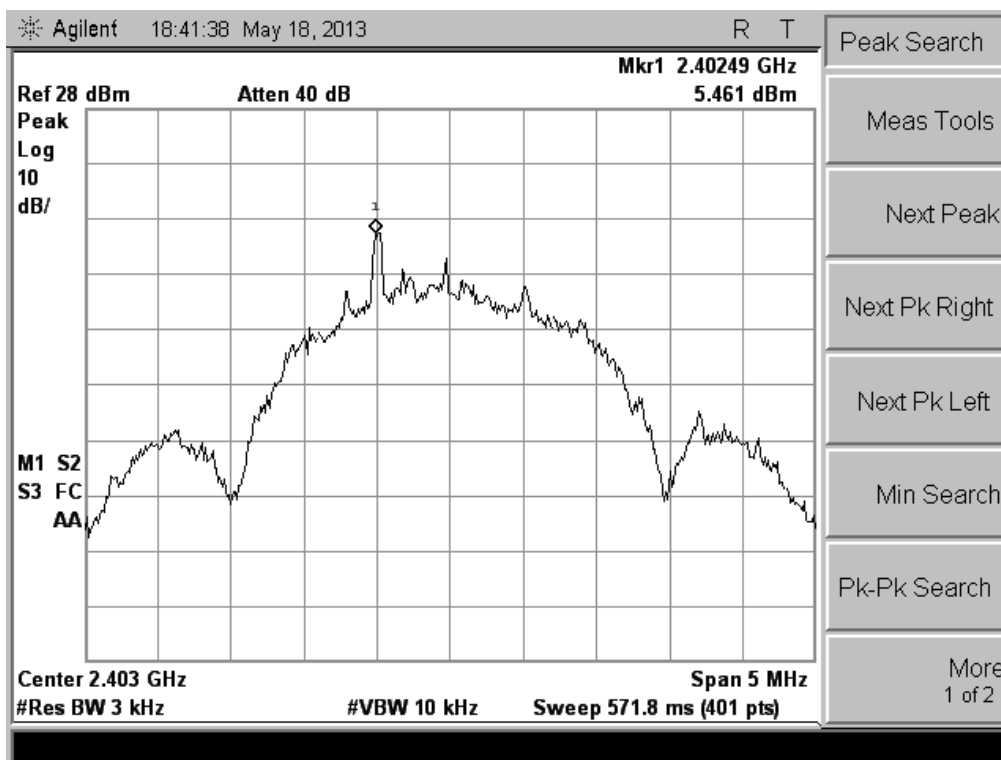

(CH Low)

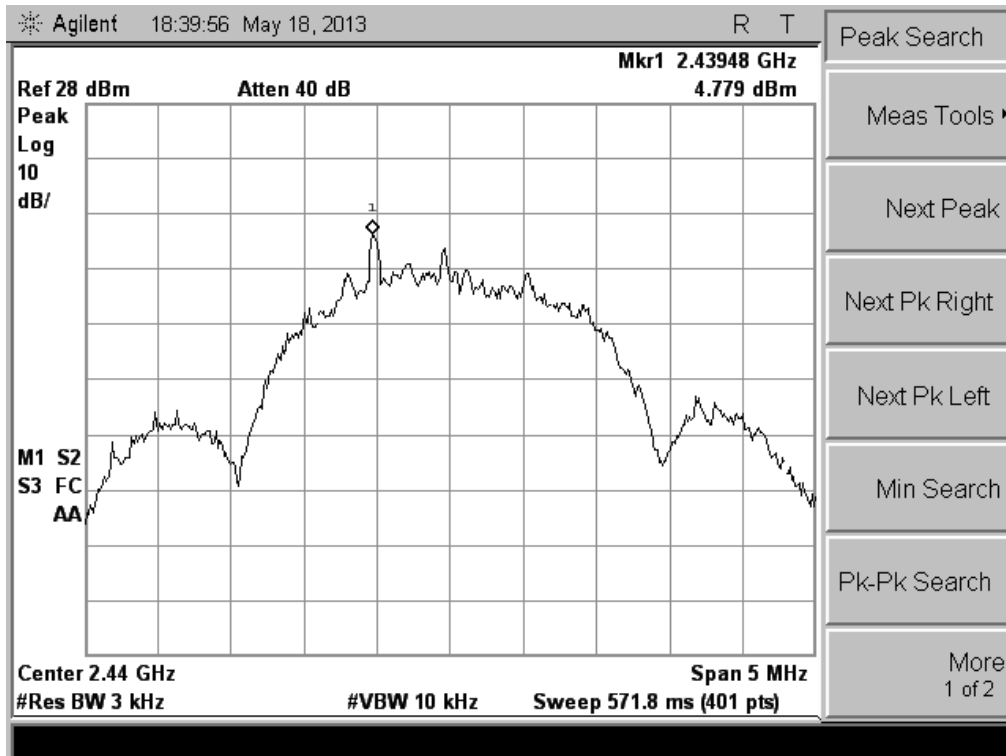

(CH Mid)

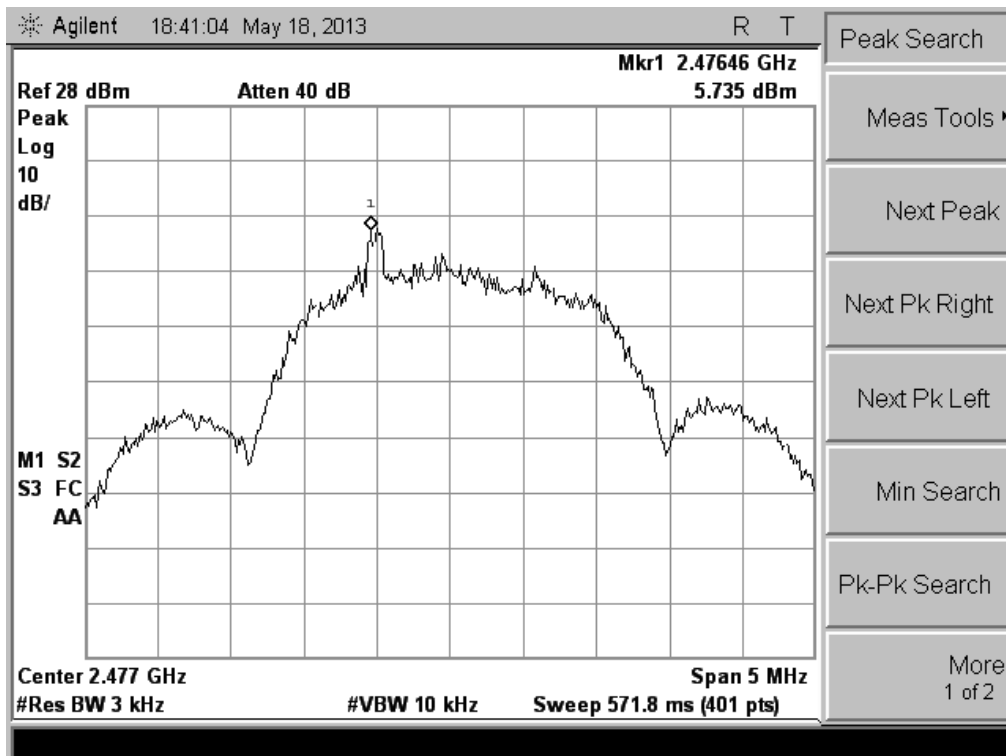

(CH High)

5.6 Conducted Emission

5.6.1 Definition

According to FCC section 15.207, for an intentional radiator that is designed to be connected to the public utility (AC) power line, the radio frequency voltage that is conducted back onto the AC power line on any frequency or frequencies, within the band 150 kHz to 30 MHz, shall not exceed the limits in the following table, as measured using a 50 μ H/50 ohms line impedance stabilization network (LISN).

Frequency	Maximum RF Line Voltage	
	Q.P.(dBuV)	Average(dBuV)
150kHz-500kHz	66-56	56-46
500kHz-5MHz	56	46
5MHz-30MHz	60	50

Note:

1. The lower limit shall apply at the transition frequency.
2. The limit decreases linearly with the logarithm of the frequency in the range 0.15 MHz to 0.50 MHz

5.6.2 Test Description

The EUT is powered by the Battery charged with the AC Adapter which is powered by 120V, 60Hz AC mains supply. The path loss as the factor is calibrated to correct the reading. During the measurement, the EUT is activated and is set to operate at maximum power.

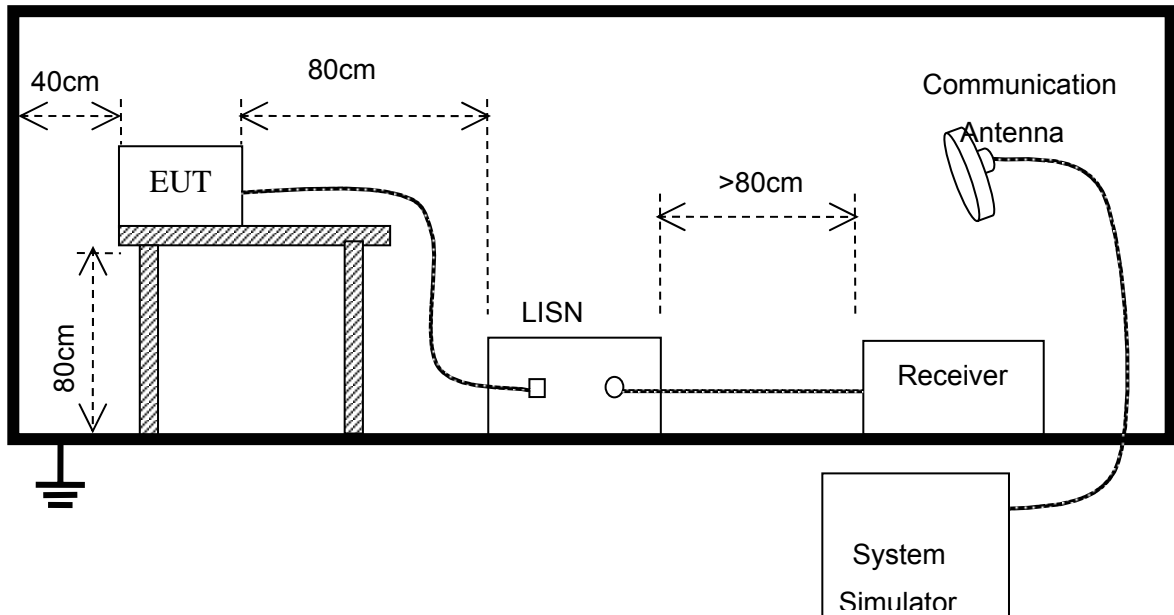

5.6.3 Test Result



Address:No.5,Langshan 2nd Rd., North Hi-Tech Industrial park
Guangdong ,China
Tel: 0755-86170306 Fax: 0755-86170310

Conducted Emission Measurement

File :H1208 Data :#4 Date: 2013-05-13 Time: 13:57:16

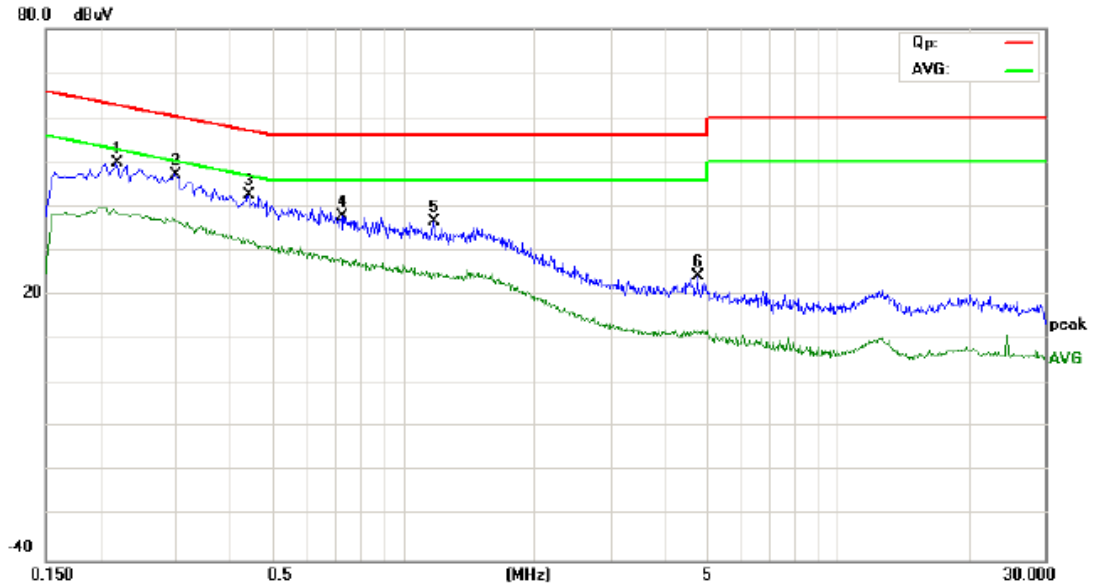

Site site #1 Phase: **N** Temperature: 26
 Limit: FCC Part15 B Class B QP Power: AC 120V/60Hz Humidity: 60 %
 EUT: VitaSound Personal Audio Enhancer
 M/N: PAE-300
 Mode: Normal Working
 Note:

No.	Mk.	Freq. MHz	Reading Level dBuV	Correct Factor dB	Measure- ment dBuV	Limit dBuV	Over dB	Detector	Comment
1	*	0.2180	38.08	11.88	49.96	62.89	-12.93	peak	
2		0.2980	35.95	11.35	47.30	60.30	-13.00	peak	
3		0.4380	32.13	10.41	42.54	57.10	-14.56	peak	
4		0.7220	27.73	10.00	37.73	56.00	-18.27	peak	
5		1.1700	26.82	9.83	36.65	56.00	-19.35	peak	
6		4.7580	12.55	11.76	24.31	56.00	-31.69	peak	

*:Maximum data x:Over limit !:over margin



Address:No.5,Langshan 2nd Rd., North Hi-Tech Industrial park
 Guangdong ,China
 Tel: 0755-86170306 Fax: 0755-86170310

Conducted Emission Measurement

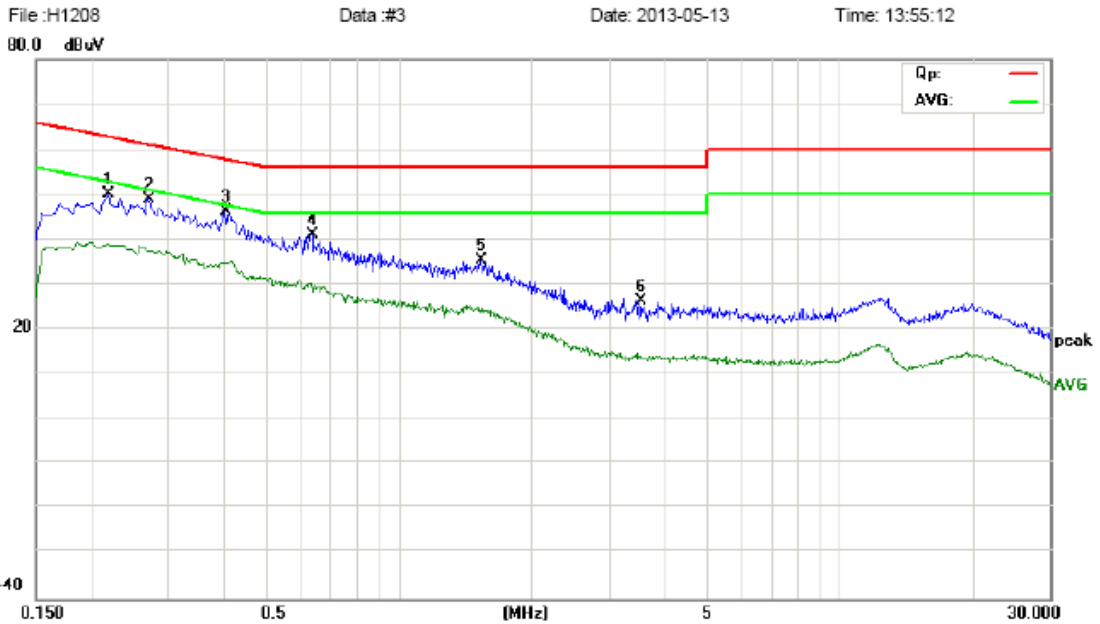

Site site #1 Phase: **L1** Temperature: 26
 Limit: FCC Part15 B Class B QP Power: AC 120V/60Hz Humidity: 60 %
 EUT: VitaSound Personal Audio Enhancer
 M/N: PAE-300
 Mode: Normal Working
 Note:

No. Mk.	Freq. MHz	Reading Level dBuV	Correct Factor dB	Measure-ment dBuV	Limit dBuV	Over dB	Detector	Comment
1	0.2180	38.41	11.88	50.29	62.89	-12.60	peak	
2	0.2700	37.57	11.53	49.10	61.12	-12.02	peak	
3 *	0.4020	35.49	10.65	46.14	57.81	-11.67	peak	
4	0.6340	31.25	10.00	41.25	56.00	-14.75	peak	
5	1.5340	25.97	9.47	35.44	56.00	-20.56	peak	
6	3.5140	15.91	10.51	26.42	56.00	-29.58	peak	

*:Maximum data x:Over limit !:over margin

5.7 Radiated Emission

5.7.1 Definition

According to FCC section 15.247(d), radiated emission outside the frequency band attenuation below the general limits specified in § 15.209(a) is not required. In addition, radiated emissions which fall in the restricted bands, as defined in § 15.205(a), must also comply with the radiated emission limits specified in § 15.209(a) (see § 15.205(c)).

According to FCC section 15.209 (a), except as provided elsewhere in this subpart, the emissions from an intentional radiator shall not exceed the field strength levels specified in the following table:

Frequency (MHz)	Field Strength ($\mu\text{V}/\text{m}$)	Measurement Distance (m)
0.009 - 0.490	2400/F(kHz)	300
0.490 - 1.705	24000/F(kHz)	30
1.705 - 30.0	30	30
30 - 88	100	3
88 - 216	150	3
216 - 960	200	3
Above 960	500	3

As shown in FCC section 15.35(b), for frequencies above 1000MHz, the field strength limits are based on average detector. When average radiated emission measurements are specified in this part, including emission measurements below 1000MHz, there also is a limit on the radio frequency emissions, as measured using instrumentation with a peak detector function, corresponding to 20dB above the maximum permitted average limit for the frequency being investigated unless a different peak emission limit is otherwise specified in the rules.

5.7.2 Test Description

A. Test Setup:

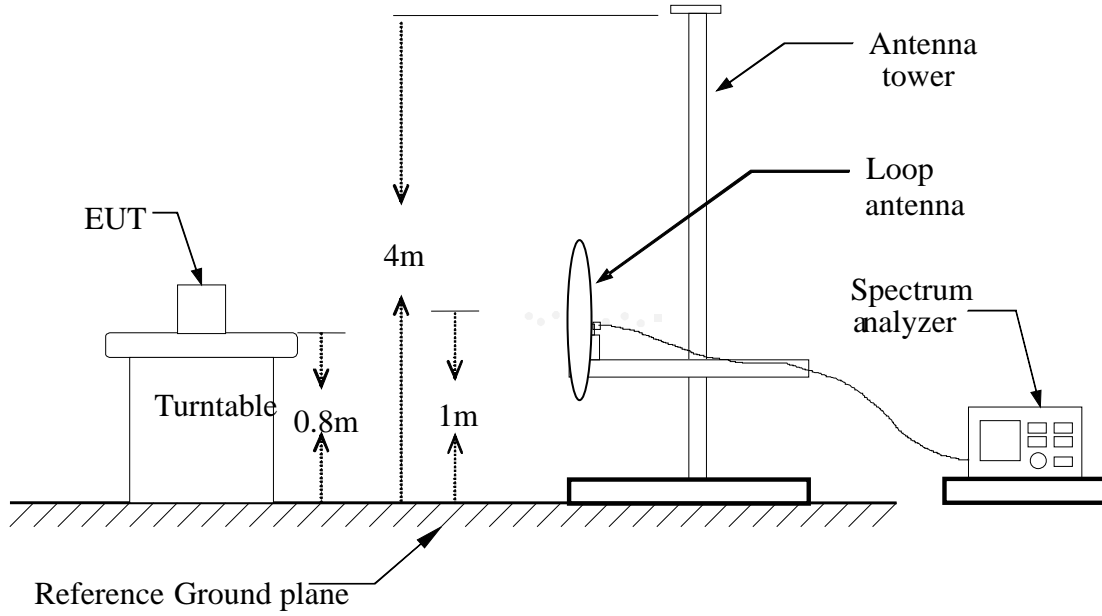

Blow 1GHz:

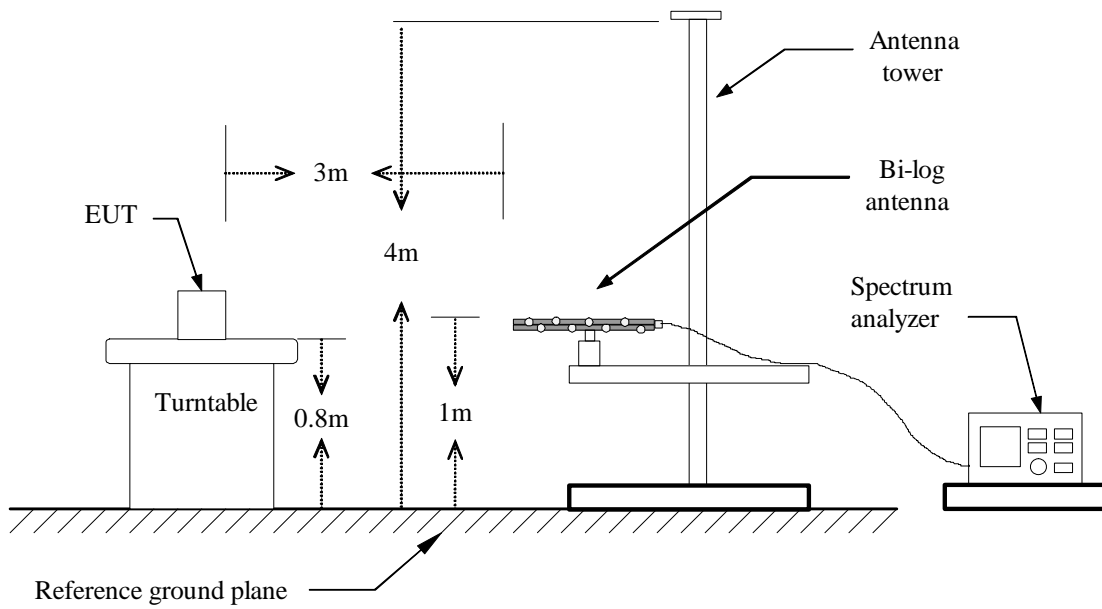

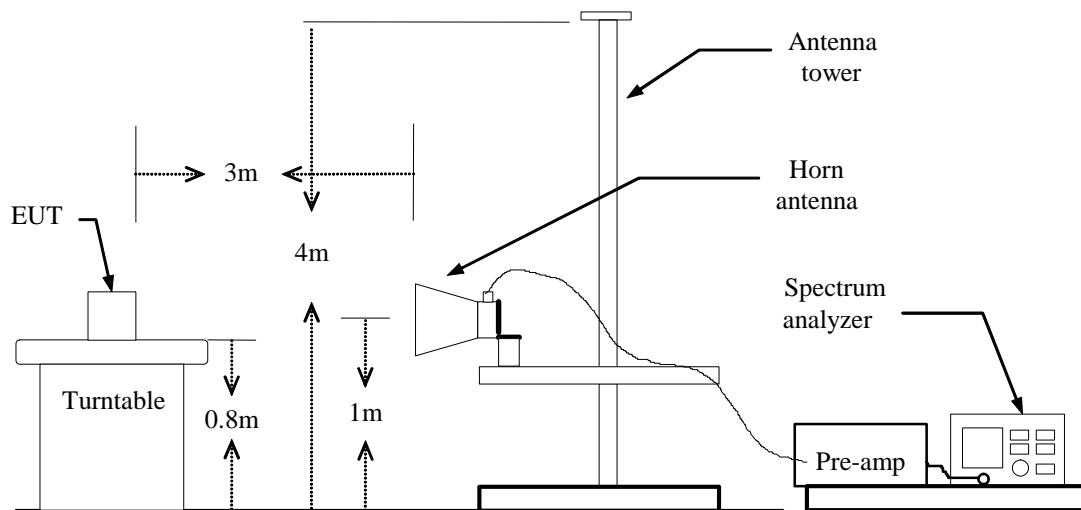
Above 1GHz:**B. Test procedures**

1. The EUT is placed on a turntable, which is 0.8m above ground plane.
2. The turntable shall be rotated for 360 degrees to determine the position of maximum emission level.
3. EUT is set 3m away from the receiving antenna, which is varied from 1m to 4m to find out the highest emissions.
4. Maximum procedure was performed on the six highest emissions to ensure EUT compliance.
5. And also, each emission was to be maximized by changing the polarization of receiving antenna both horizontal and vertical.
6. Set the spectrum analyzer in the following setting as:
 - Below 1GHz: RBW=100 kHz / VBW=300 kHz / Sweep=AUTO
 - Above 1GHz : (a) PEAK: RBW=VBW=1MHz / Sweep=AUTO
 - (b) AVERAGE: RBW=1MHz / VBW=10Hz / Sweep=AUTO
7. Repeat above procedures until the measurements for all frequencies are complete.

5.7.3 Test Result

Form 9KHz to 30MHz:

Freq. (MHz)	Ant. Pol H/V	Peak Reading (dBuV)	AV Reading (dBuV)	Ant. / CL CF (dB)	Actual Fs		Peak Limit (dBuV/m)	AV Limit (dBuV/m)	AV Margin (dB)
					Peak (dBuV/m)	AV (dBuV/m)			
N/A	H								>20
N/A	V								>20

-No detected in below 30MHz.

Form 30 MHz to 1GHz:



Address:No.5,Langshan 2nd Rd., North Hi-Tech Industrial park
Guangdong ,China
Tel: 0755-86170306 Fax: 0755-86170310

Radiated Emission Measurement

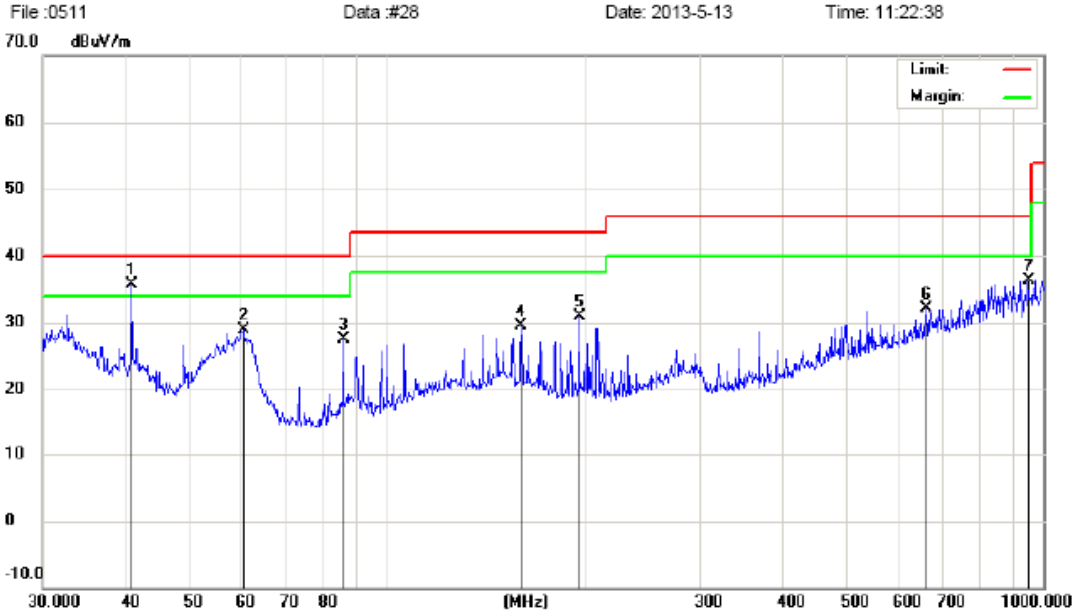

File :0511 Data :#28 Date: 2013-5-13 Time: 11:22:38
 Site site MOST 3M Polarization: *Vertical* Temperature: 26
 Limit: FCC Part15 B 3M Radiation Power: AC 110V/60Hz Humidity: 61 %
 EUT: VitaSound Personal Audio Enhancer Distance:
 M/N: PAE-300
 Mode: NORMAL WORKING
 Note:

No.	Mk.	Freq.	Reading Level	Correct Factor	Measurement	Limit	Over	Antenna Height	Table Degree
		MHz	dBuV	dB	dBuV/m	dBuV/m	dB	cm	degree
1	*	40.8446	20.27	15.52	35.79	40.00	-4.21	peak	
2		60.4919	18.01	10.84	28.85	40.00	-11.15	peak	
3		85.8983	16.08	11.40	27.48	40.00	-12.52	peak	
4		160.3456	12.16	17.30	29.46	43.50	-14.04	peak	
5		196.5098	13.86	17.13	30.99	43.50	-12.51	peak	
6		663.4728	7.84	24.30	32.14	46.00	-13.86	peak	
7		948.7610	8.39	27.86	36.25	46.00	-9.75	peak	

*:Maximum data x:Over limit !:over margin



Address:No.5,Langshan 2nd Rd., North Hi-Tech Industrial park
Guangdong ,China
Tel: 0755-86170306 Fax: 0755-86170310

Radiated Emission Measurement

File :0511 Data :#27 Date: 2013-5-13 Time: 11:20:11

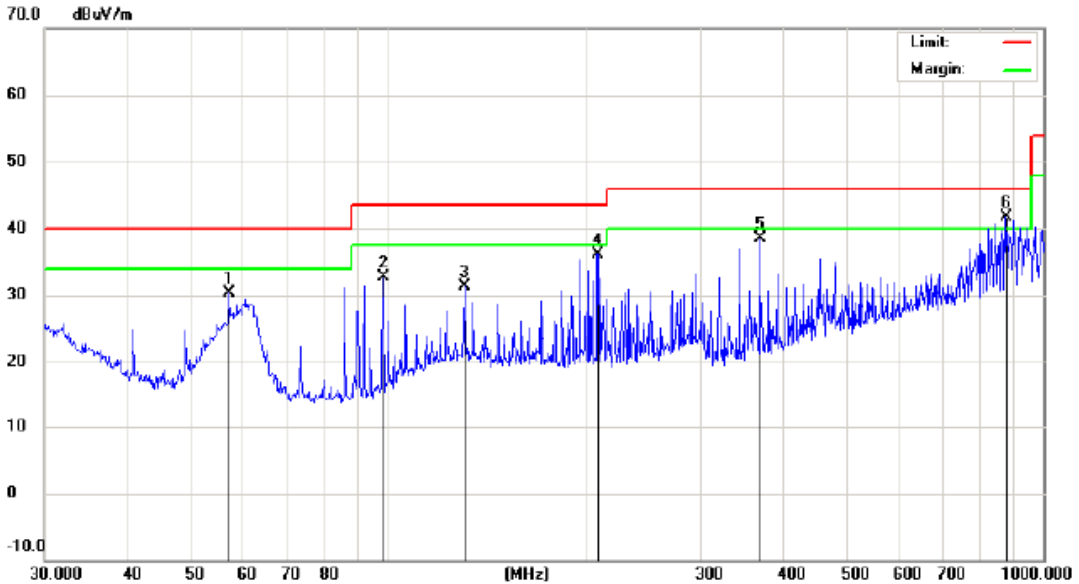

Site site MOST 3M Polarization: *Horizontal* Temperature: 26
 Limit: FCC Part15 B 3M Radiation Power: AC 110V/60Hz Humidity: 61 %
 EUT: VitaSound Personal Audio Enhancer Distance:
 M/N: PAE-300
 Mode: NORMAL WORKING
 Note:

No.	Mk.	Freq.	Reading Level	Correct Factor	Measurement	Limit	Over	Antenna Height	Table Degree	
		MHz	dBuV	dB	dBuV/m	dBuV/m	dB	cm	degree	Comment
1		57.1914	19.73	10.66	30.39	40.00	-9.61			peak
2		98.1419	19.78	12.86	32.64	43.50	-10.86			peak
3		130.8369	13.61	17.66	31.27	43.50	-12.23			peak
4		208.5803	19.95	16.12	36.07	43.50	-7.43			peak
5		369.4047	20.36	18.21	38.57	46.00	-7.43			peak
6	*	875.2470	14.57	27.05	41.62	46.00	-4.38			peak

*:Maximum data x:Over limit !:over margin

Above 1 GHz

Operation Mode: CH Low
Temperature: 20°C
Humidity: 70 % RH

Test Date: 2013-05-13
Tested by: Habby Guo
Polarity: Ver. / Hor.

Freq. (MHz)	Ant. Pol H/V	Peak Reading (dBuV)	AV Reading (dBuV)	Ant. / CL CF (dB)	Actual Fs		Peak Limit (dBuV/m)	AV Limit (dBuV/m)	AV Margin (dB)
					Peak (dBuV/m)	AV (dBuV/m)			
4806.20	H	47.56	27.35	11.58	59.14	38.93	74.00	54.00	-15.07
N/A	H								
4806.20	V	59.08	26.62	11.58	70.66	38.20	74.00	54.00	-15.80
N/A	V								

Notes:

1. Measuring frequencies from 1 GHz to the 10th harmonic of highest fundamental frequency.
2. Radiated emissions measured in frequency above 1000MHz were made with an instrument using peak/average detector mode.
3. Average test would be performed if the peak result were greater than the average limit or as required by the applicant.
4. Data of measurement within this frequency range shown “ --- ” in the table above means the reading of emissions are attenuated more than 20dB below the permissible limits or the field strength is too small to be measured.
5. Measurements above show only up to 6 maximum emissions noted, or would be lesser, with “ N/A ” remark, if no specific emissions from the EUT are recorded (ie:
6. margin>20dB from the applicable limit) and considered that's already beyond the background noise floor.
7. Margin (dB) = Remark result (dBuV/m) – Average limit (dBuV/m).
8. Only the worse test data was been recorded in the report.

Operation Mode: CH Mid

Test Date: 2013-05-13

Temperature: 20°C

Tested by: Habby Guo

Humidity: 70 % RH

Polarity: Ver. / Hor.

Freq. (MHz)	Ant. Pol H/V	Peak Reading (dBuV)	AV Reading (dBuV)	Ant. / CL CF (dB)	Actual Fs		Peak Limit (dBuV/m)	AV Limit (dBuV/m)	AV Margin (dB)
					Peak (dBuV/m)	AV (dBuV/m)			
4880.12	H	55.25	29.11	11.61	66.86	40.72	74.00	54.00	-13.28
N/A	H								
4880.12	V	51.26	28.45	11.61	62.87	40.06	74.00	54.00	-13.94
N/A	V								

Notes:

1. Measuring frequencies from 1 GHz to the 10th harmonic of highest fundamental frequency.
2. Radiated emissions measured in frequency above 1000MHz were made with an instrument using peak/average detector mode.
3. Average test would be performed if the peak result were greater than the average limit or as required by the applicant.
4. Data of measurement within this frequency range shown “ --- ” in the table above means the reading of emissions are attenuated more than 20dB below the permissible limits or the field strength is too small to be measured.
5. Measurements above show only up to 6 maximum emissions noted, or would be lesser, with “ N/A ” remark, if no specific emissions from the EUT are recorded (ie: margin>20dB from the applicable limit) and considered that's already beyond the background noise floor.
6. Margin (dB) = Remark result (dBuV/m) – Average limit (dBuV/m).
7. Only the worse test data was been recorded in the report.

Operation Mode: CH High
Temperature: 20°C
Humidity: 70 % RH

Test Date: 2013-05-13
Tested by: Habby Guo
Polarity: Ver. / Hor.

Freq. (MHz)	Ant. Pol H/V	Peak Reading (dBuV)	AV Reading (dBuV)	Ant. / CL CF (dB)	Actual Fs		Peak Limit (dBuV/m)	AV Limit (dBuV/m)	AV Margin (dB)
					Peak (dBuV/m)	AV (dBuV/m)			
4954.05	H	53.51	29.75	11.64	65.15	41.39	74.00	54.00	-12.61
N/A	H								
4954.05	V	48.82	28.50	11.64	60.46	40.14	74.00	54.00	-13.86
N/A	V								

Notes:

1. Measuring frequencies from 1 GHz to the 10th harmonic of highest fundamental frequency.
2. Radiated emissions measured in frequency above 1000MHz were made with an instrument using peak/average detector mode.
3. Average test would be performed if the peak result were greater than the average limit or as required by the applicant.
4. Data of measurement within this frequency range shown “ --- ” in the table above means the reading of emissions are attenuated more than 20dB below the permissible limits or the field strength is too small to be measured.
5. Measurements above show only up to 6 maximum emissions noted, or would be lesser, with “ N/A ” remark, if no specific emissions from the EUT are recorded (ie: margin>20dB from the applicable limit) and considered that's already beyond the background noise floor.
6. Margin (dB) = Remark result (dBuV/m) – Average limit (dBuV/m).
7. Only the worse test data was been recorded in the report.

APPENDIX 1
PHOTOGRAPHS OF TEST SETUP

CONDUCTED TEST SETUP

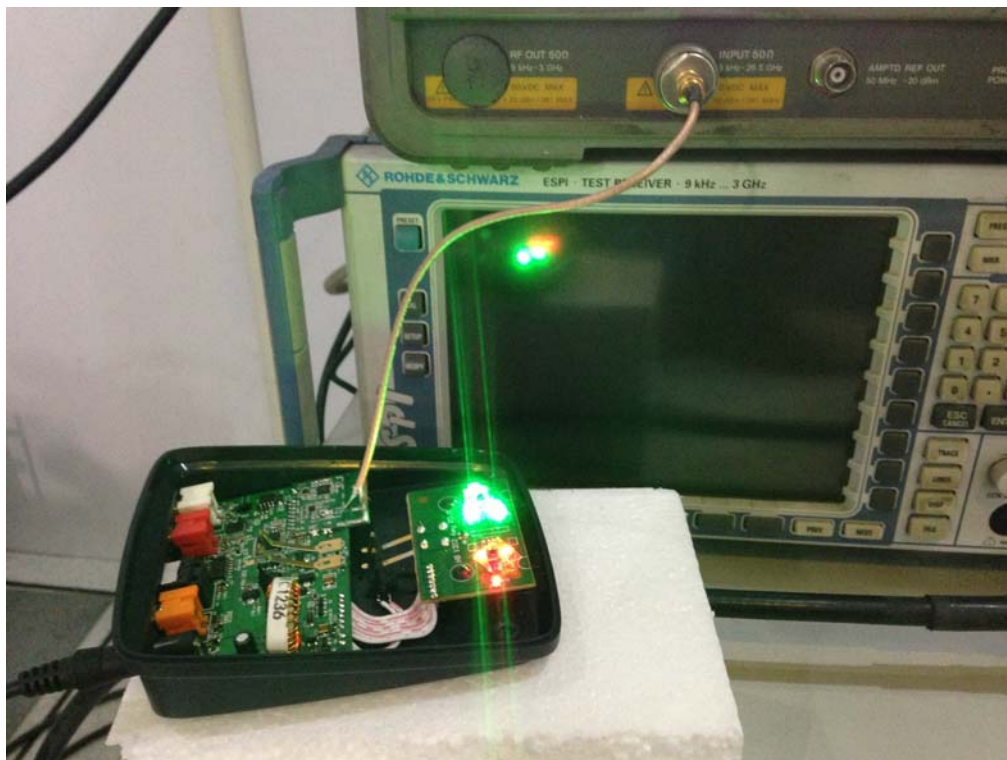

RE TEST SETUP

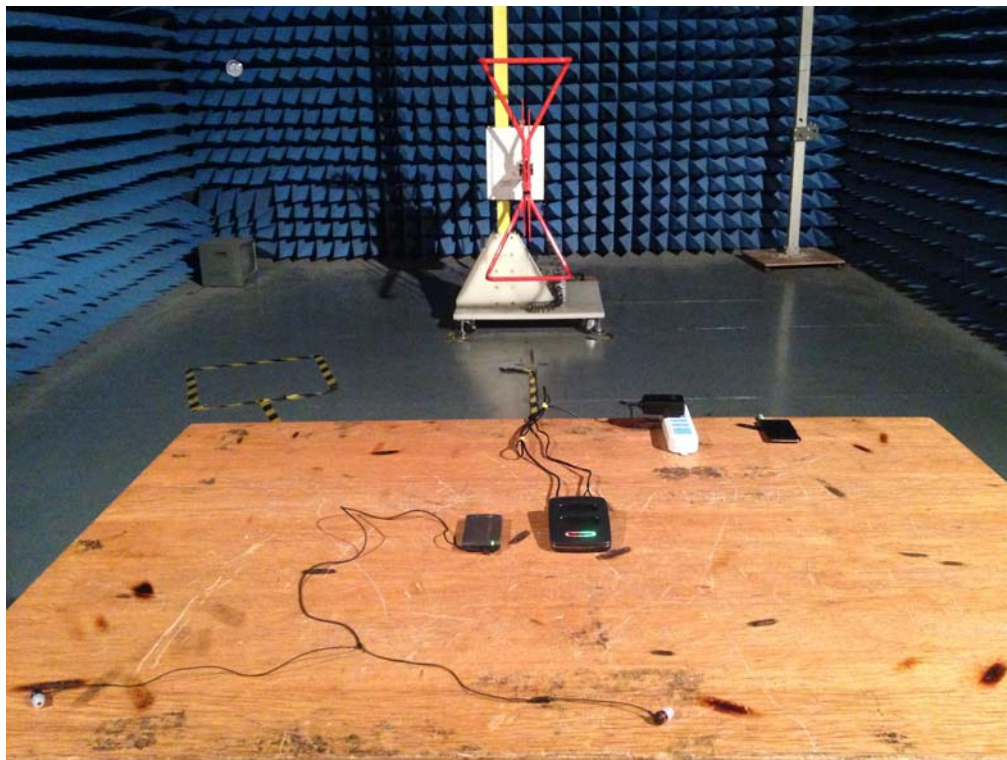

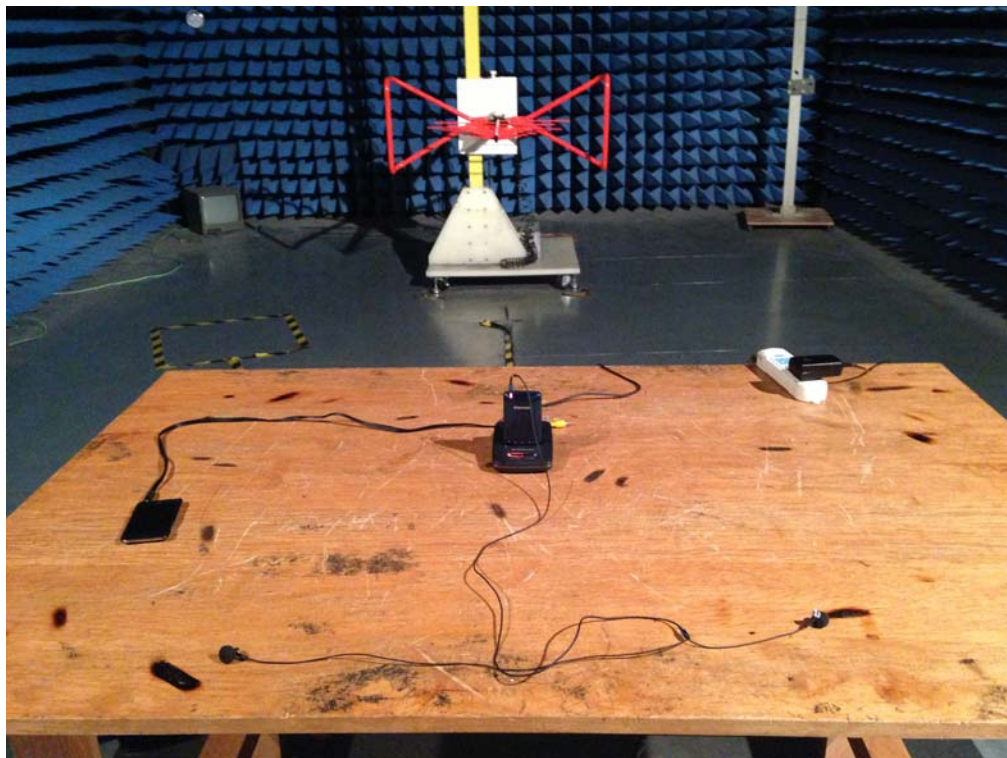

CE TEST SETUP



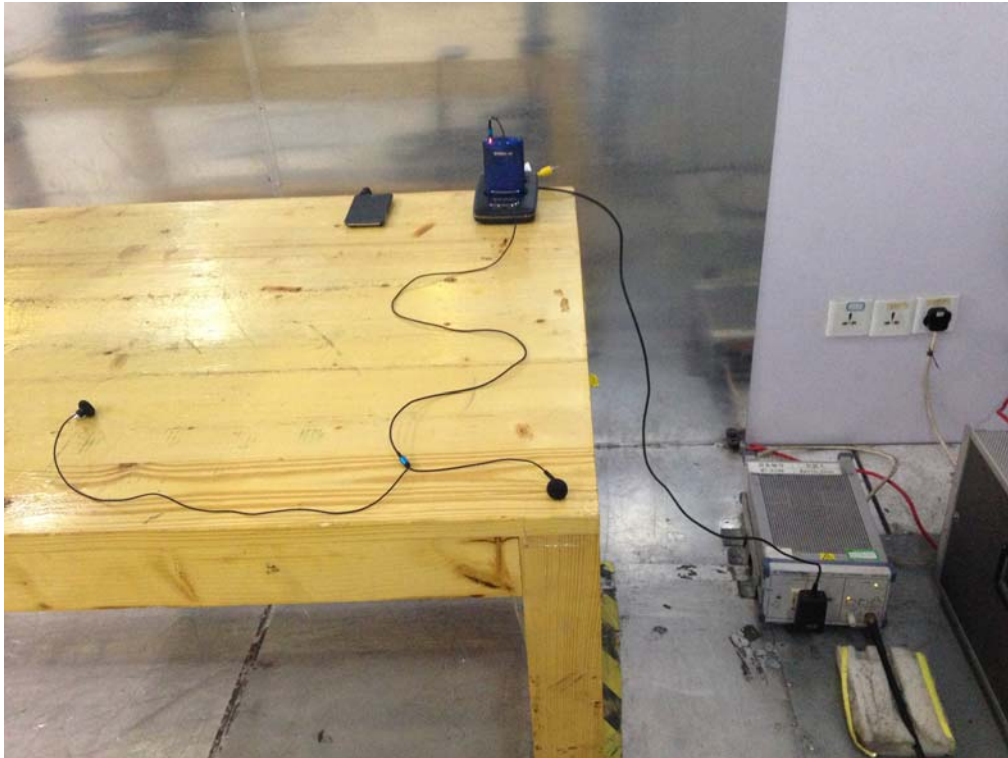

-----END OF REPORT-----