

## FCC Test Report

**Report No.:** RF160323C07-1

**FCC ID:** S4A50-0101-QT-44

**Test Model:** Amulet 655

**Series Model:** Amulet 6XYzzzzzz (where "X" can be 0-9, "Y" can be 0-9; "zzzzzz" can be any combination of "0-9", "a-z", "-", "/" or blank for marketing purpose)

**Received Date:** Mar. 22, 2016

**Test Date:** Apr. 19 ~ Sep. 20, 2016

**Issued Date:** May 09, 2016

**Applicant:** Entone Technologies (HK) Limited

**Address:** Level 28, Saxon Tower, 7 Cheung Shun Street, Lai Chi Kok, Hong Kong

**Issued By:** Bureau Veritas Consumer Products Services (H.K.) Ltd., Taoyuan Branch

**Lab Address:** No. 47-2, 14th Ling, Chia Pau Vil., Lin Kou Dist., New Taipei City, Taiwan, R.O.C.

**Test Location:** No. 19, Hwa Ya 2nd Rd., Wen Hwa Vil., Kwei Shan Dist., Taoyuan City 33383, TAIWAN (R.O.C.)



This report is for your exclusive use. Any copying or replication of this report to or for any other person or entity, or use of our name or trademark, is permitted only with our prior written permission. This report sets forth our findings solely with respect to the test samples identified herein. The results set forth in this report are not indicative or representative of the quality or characteristics of the lot from which a test sample was taken or any similar or identical product unless specifically and expressly noted. Our report includes all of the tests requested by you and the results thereof based upon the information that you provided to us. You have 60 days from date of issuance of this report to notify us of any material error or omission caused by our negligence, provided, however, that such notice shall be in writing and shall specifically address the issue you wish to raise. A failure to raise such issue within the prescribed time shall constitute your unqualified acceptance of the completeness of this report, the tests conducted and the correctness of the report contents. Unless specific mention, the uncertainty of measurement has been explicitly taken into account to declare the compliance or non-compliance to the specification. This report should not be used by the client to claim product certification, approval, or endorsement by TAF or any government agencies.

## Table of Contents

<b>Release Control Record</b> .....	<b>4</b>
<b>1 Certificate of Conformity</b> .....	<b>5</b>
<b>2 Summary of Test Results</b> .....	<b>6</b>
2.1 Measurement Uncertainty .....	6
2.2 Modification Record .....	6
<b>3 General Information</b> .....	<b>7</b>
3.1 General Description of EUT .....	7
3.2 Description of Test Modes .....	8
3.2.1 Test Mode Applicability and Tested Channel Detail .....	9
3.3 Description of Support Units .....	10
3.3.1 Configuration of System under Test .....	10
3.4 General Description of Applied Standards .....	11
<b>4 Test Types and Results</b> .....	<b>12</b>
4.1 Radiated Emission and Bandedge Measurement.....	12
4.1.1 Limits of Radiated Emission and Bandedge Measurement .....	12
4.1.2 Test Instruments .....	13
4.1.3 Test Procedures.....	14
4.1.4 Deviation from Test Standard .....	14
4.1.5 Test Set Up .....	15
4.1.6 EUT Operating Conditions.....	15
4.1.7 Test Results .....	16
4.2 Conducted Emission Measurement .....	21
4.2.1 Limits of Conducted Emission Measurement .....	21
4.2.2 Test Instruments .....	21
4.2.3 Test Procedures.....	22
4.2.4 Deviation from Test Standard .....	22
4.2.5 Test Setup.....	22
4.2.6 EUT Operating Conditions.....	22
4.2.7 Test Results .....	23
4.3 6dB Bandwidth Measurement .....	27
4.3.1 Limits of 6dB Bandwidth Measurement .....	27
4.3.2 Test Setup.....	27
4.3.3 Test Instruments .....	27
4.3.4 Test Procedure .....	27
4.3.5 Deviation from Test Standard .....	27
4.3.6 EUT Operating Conditions.....	27
4.3.7 Test Result.....	28
4.4 Conducted Output Power Measurement.....	29
4.4.1 Limits of Conducted Output Power Measurement .....	29
4.4.2 Test Setup.....	29
4.4.3 Test Instruments .....	29
4.4.4 Test Procedures.....	29
4.4.5 Deviation from Test Standard .....	29
4.4.6 EUT Operating Conditions.....	29
4.4.7 Test Results .....	29
4.5 Power Spectral Density Measurement.....	30
4.5.1 Limits of Power Spectral Density Measurement .....	30
4.5.2 Test Setup.....	30
4.5.3 Test Instruments .....	30
4.5.4 Test Procedure .....	30
4.5.5 Deviation from Test Standard .....	30
4.5.6 EUT Operating Condition .....	30

4.5.7 Test Results .....	31
4.6 Conducted Out of Band Emission Measurement.....	32
4.6.1 Limits of Conducted Out of Band Emission Measurement.....	32
4.6.2 Test Setup.....	32
4.6.3 Test Instruments .....	32
4.6.4 Test Procedure .....	32
4.6.5 Deviation from Test Standard .....	32
4.6.6 EUT Operating Condition .....	32
4.6.7 Test Results .....	32
<b>5 Pictures of Test Arrangements.....</b>	<b>34</b>
<b>Appendix – Information on the Testing Laboratories .....</b>	<b>35</b>



### Release Control Record

Issue No.	Description	Date Issued
RF160323C07-1	Original release	Sep. 20, 2016

## 1 Certificate of Conformity

**Product:** High Definition IP TV receiver

**Brand:** entone, amino

**Test Model:** Amulet 655

**Series Model:** Amulet 6XYzzzzzz (where "X" can be 0-9, "Y" can be 0-9; "zzzzzz" can be any combination of "0-9", "a-z", "-", "/", or blank for marketing purpose)

**Sample Status:** Engineering Sample

**Applicant:** Entone Technologies (HK) Limited

**Test Date:** Apr. 19 ~ Sep. 20, 2016

**Standards:** 47 CFR FCC Part 15, Subpart C (Section 15.247)  
ANSI C63.10:2013

The above equipment has been tested by **Bureau Veritas Consumer Products Services (H.K.) Ltd., Taoyuan Branch**, and found compliance with the requirement of the above standards. The test record, data evaluation & Equipment Under Test (EUT) configurations represented herein are true and accurate accounts of the measurements of the sample's EMC characteristics under the conditions specified in this report.

**Prepared by :**  , **Date:** Sep. 20, 2016  
Polly Chien / Specialist

**Approved by :**  , **Date:** Sep. 20, 2016  
Ken Liu / Senior Manager

## 2 Summary of Test Results

47 CFR FCC Part 15, Subpart C (Section 15.247)			
FCC Clause	Test Item	Result	Remarks
15.207	AC Power Conducted Emission	Pass	Meet the requirement of limit. Minimum passing margin is -18.77dB at 0.48203MHz.
15.205 / 15.209 / 15.247(d)	Radiated Emissions and Band Edge Measurement	Pass	Meet the requirement of limit. Minimum passing margin is -0.1dB at 4804.00MHz.
15.247(d)	Antenna Port Emission	Pass	Meet the requirement of limit.
15.247(a)(2)	6dB bandwidth	Pass	Meet the requirement of limit.
15.247(b)	Conducted power	Pass	Meet the requirement of limit.
15.247(e)	Power Spectral Density	Pass	Meet the requirement of limit.
15.203	Antenna Requirement	Pass	Antenna connector is IPEX not a standard connector.

### 2.1 Measurement Uncertainty

Where relevant, the following measurement uncertainty levels have been estimated for tests performed on the EUT as specified in CISPR 16-4-2:

Measurement	Frequency	Expanded Uncertainty (k=2) ( $\pm$ )
Conducted Emissions at mains ports	150kHz ~ 30MHz	2.44 dB
Radiated Emissions up to 1 GHz	30MHz ~ 200MHz	3.59 dB
	200MHz ~ 1000MHz	3.60 dB
Radiated Emissions above 1 GHz	1GHz ~ 18GHz	2.29 dB
	18GHz ~ 40GHz	2.29 dB

### 2.2 Modification Record

There were no modifications required for compliance.

### 3 General Information

#### 3.1 General Description of EUT

Product	High Definition IP TV receiver
Brand	entone, amino
Test Model	Amulet 655
Series Model	Amulet 6XYzzzzzz (where “X” can be 0-9, “Y” can be 0-9; “zzzzzz” can be any combination of “0-9”, “a-z”, “-”, “/” or blank for marketing purpose)
Model Difference	Refer to Note for more details
Sample Status	Engineering Sample
Power Supply Rating	12Vdc (adapter)
Modulation Type	GFSK
Transfer Rate	1Mbps
Operating Frequency	2402MHz~2480MHz
Number of Channel	40
Channel Spacing	2MHz
Output Power	0.551mW
Antenna Type	PIFA antenna with 1.8dBi gain
Antenna Connector	IPEX
Accessory Device	Adapter, Remote controller (Brand: Stylus, Nova)
Data Cable Supplied	2m shielded HDMI cable without core 2m non-shielded RJ45 cable without core

Note:

1. All models are listed as below.

Brand	Model	Difference
entone, amino	Amulet 655 (Main test model)	Marketing purpose
	Amulet 6XYzzzzzz (where “X” can be 0-9, “Y” can be 0-9; “zzzzzz” can be any combination of “0-9”, “a-z”, “-”, “/” or blank for marketing purpose)	

2. The EUT uses following adapter.

Brand	Asian Power Devices Inc.
Model	WA-36A12R
Input Power	100-240Vac, 50-60Hz, 0.9A Max.
Output Power	12Vdc, 3A
Power Line	1.8m DC cable with 1 core attached on adapter

3. The EUT uses 500GB / 1TB HDD.

### 3.2 Description of Test Modes

40 channels are provided to this EUT:

Channel	Freq. (MHz)	Channel	Freq. (MHz)	Channel	Freq. (MHz)	Channel	Freq. (MHz)
0	2402	10	2422	20	2442	30	2462
1	2404	11	2424	21	2444	31	2464
2	2406	12	2426	22	2446	32	2466
3	2408	13	2428	23	2448	33	2468
4	2410	14	2430	24	2450	34	2470
5	2412	15	2432	25	2452	35	2472
6	2414	16	2434	26	2454	36	2474
7	2416	17	2436	27	2456	37	2476
8	2418	18	2438	28	2458	38	2478
9	2420	19	2440	29	2460	39	2480



### 3.2.1 Test Mode Applicability and Tested Channel Detail

EUT Configure Mode	Applicable to				Description
	RE $\geq$ 1G	RE $<$ 1G	PLC	APCM	
A	√	√	√	√	EUT + 1TB HDD
B	-	√	√	-	EUT + 500GB HDD

Where RE $\geq$ 1G: Radiated Emission above 1GHz & Bandedge Measurement  
 RE $<$ 1G: Radiated Emission below 1GHz  
 PLC: Power Line Conducted Emission  
 APCM: Antenna Port Conducted Measurement

Note:

1. The EUT had been pre-tested on the positioned of each 3 axis. The worst case was found when positioned on **X-plane**.
2. "-" means no effect.

#### Radiated Emission Test (Above 1GHz):

- Pre-Scan has been conducted to determine the worst-case mode from all possible combinations between available modulations, data rates and antenna ports (if EUT with antenna diversity architecture).
- Following channel(s) was (were) selected for the final test as listed below.

EUT Configure Mode	Available Channel	Tested Channel	Modulation Type	Date Rate (Mbps)
A	0 to 39	0, 19, 39	GFSK	1

#### Radiated Emission Test (Below 1GHz):

- Pre-Scan has been conducted to determine the worst-case mode from all possible combinations between available modulations, data rates and antenna ports (if EUT with antenna diversity architecture).
- Following channel(s) was (were) selected for the final test as listed below.

EUT Configure Mode	Available Channel	Tested Channel	Modulation Type	Date Rate (Mbps)
A, B	0 to 39	0	GFSK	1

#### Power Line Conducted Emission Test:

- Pre-Scan has been conducted to determine the worst-case mode from all possible combinations between available modulations, data rates and antenna ports (if EUT with antenna diversity architecture).
- Following channel(s) was (were) selected for the final test as listed below.

EUT Configure Mode	Available Channel	Tested Channel	Modulation Type	Date Rate (Mbps)
A, B	0 to 39	0	GFSK	1

#### Antenna Port Conducted Measurement:

- This item includes all test value of each mode, but only includes spectrum plot of worst value of each mode.
- Pre-Scan has been conducted to determine the worst-case mode from all possible combinations between available modulations, data rates and antenna ports (if EUT with antenna diversity architecture).
- Following channel(s) was (were) selected for the final test as listed below.

EUT Configure Mode	Available Channel	Tested Channel	Modulation Type	Date Rate (Mbps)
A	0 to 39	0, 19, 39	GFSK	1

**Test Condition:**

Applicable to	Environmental Conditions	Input Power	Tested by
RE≥1G	25 deg. C, 65% RH	120Vac, 60Hz	Chris Lin
RE<1G	25 deg. C, 65% RH	120Vac, 60Hz	Chris Lin
PLC	25 deg. C, 65% RH	120Vac, 60Hz	Chris Lin
APCM	25 deg. C, 60% RH	120Vac, 60Hz	Frank Liu

**3.3 Description of Support Units**

The EUT has been tested as an independent unit together with other necessary accessories or support units. The following support units or accessories were used to form a representative test configuration during the tests.

ID	Product	Brand	Model No.	Serial No.	FCC ID	Remarks
A.	USB Flash Drive	HP	v250W	01	NA	-
B.	Notebook	DELL	E5410	6RP2YM1	FCC DoC Approved	-

Note:

1. All power cords of the above support units are non-shielded (1.8m).
2. Items B acted as communication partners to transfer data.

ID	Descriptions	Qty.	Length (m)	Shielding (Yes/No)	Cores (Qty.)	Remarks
1.	IR	1	1	-	0	Provided by manufacturer
2.	HDMI	1	2	Y	0	Accessory of EUT
3.	RJ45, Cat5e	1	2	N	0	Accessory of EUT
4.	Fiber	1	1.8	N	0	-
5.	AV	1	1.45	N	0	Provided by manufacturer
6.	RJ45, Cat5e	1	3	N	0	-

**3.3.1 Configuration of System under Test**

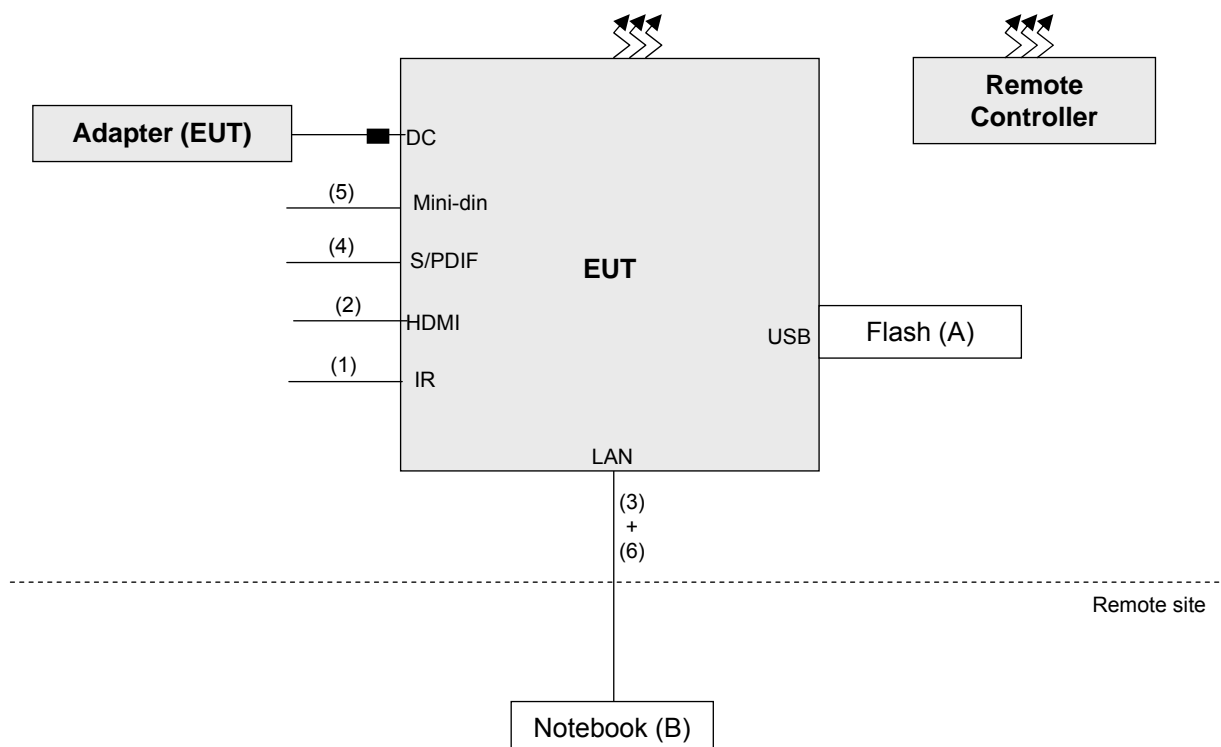

### 3.4 General Description of Applied Standards

The EUT is a RF Product. According to the specifications of the manufacturer, it must comply with the requirements of the following standards:

**FCC Part 15, Subpart C (15.247)**  
**558074 D01 DTS Meas Guidance v03r05**  
ANSI C63.10:2013

All test items have been performed and recorded as per the above standards.

Note: The EUT has been verified to comply with the requirements of FCC Part 15, Subpart B, Class B (DoC).  
The test report has been issued separately.

## 4 Test Types and Results

### 4.1 Radiated Emission and Bandedge Measurement

#### 4.1.1 Limits of Radiated Emission and Bandedge Measurement

Radiated emissions which fall in the restricted bands must comply with the radiated emission limits specified as below table. Other emissions shall be at least 20dB below the highest level of the desired power:

Frequencies (MHz)	Field Strength (microvolts/meter)	Measurement Distance (meters)
0.009 ~ 0.490	2400/F(kHz)	300
0.490 ~ 1.705	24000/F(kHz)	30
1.705 ~ 30.0	30	30
30 ~ 88	100	3
88 ~ 216	150	3
216 ~ 960	200	3
Above 960	500	3

**Note:**

1. The lower limit shall apply at the transition frequencies.
2. Emission level (dBuV/m) = 20 log Emission level (uV/m).
3. For frequencies above 1000MHz, the field strength limits are based on average detector, however, the peak field strength of any emission shall not exceed the maximum permitted average limits, specified above by more than 20dB under any condition of modulation.

#### 4.1.2 Test Instruments

Description & Manufacturer	Model No.	Serial No.	Cal. Date	Cal. Due
Test Receiver ROHDE & SCHWARZ	ESCI	100424	Oct. 12, 2015	Oct. 11, 2016
Spectrum Analyzer ROHDE & SCHWARZ	FSP40	100039	May 03, 2016	May 02, 2017
			May 03, 2015	May 02, 2016
BILOG Antenna SCHWARZBECK	VULB9168	9168-155	Jan. 07, 2016	Jan. 06, 2017
HORN Antenna SCHWARZBECK	BBHA 9120D	9120D-1170	Jan. 08, 2016	Jan. 07, 2017
HORN Antenna SCHWARZBECK	BBHA 9170	BBHA9170241	Jan. 18, 2016	Jan. 17, 2017
Preamplifier Agilent	8449B	3008A01960	Aug. 09, 2015	Aug. 08, 2016
			Aug. 09, 2016	Aug. 08, 2017
Preamplifier Agilent	8447D	2944A10631	Aug. 09, 2015	Aug. 08, 2016
			Aug. 09, 2016	Aug. 08, 2017
RF signal cable HUBER+SUHNER	SUCOFLEX 104	Cable-CH4-02 (295012+309220)	Aug. 09, 2015	Aug. 08, 2016
			Aug. 09, 2016	Aug. 08, 2017
RF signal cable HUBER+SUHNER	SUCOFLEX 104	Cable-CH4-03(250724)	Aug. 09, 2015	Aug. 08, 2016
			Aug. 09, 2016	Aug. 08, 2017
Software BV ADT	ADT_Radiated_ V7.6.15.9.4	NA	NA	NA
Antenna Tower inn-co GmbH	MA 4000	010303	NA	NA
Antenna Tower Controller BV ADT	AT100	AT93021703	NA	NA
Turn Table BV ADT	TT100	TT93021703	NA	NA
Turn Table Controller BV ADT	SC100.	SC93021703	NA	NA
High Speed Peak Power Meter	ML2495A	0824011	Aug. 11, 2015	Aug. 10, 2016
			Aug. 11, 2016	Aug. 10, 2017
Power Sensor	MA2411B	0738171	Aug. 11, 2015	Aug. 10, 2016
			Aug. 11, 2016	Aug. 10, 2017

- Note: 1. The calibration interval of the above test instruments is 12 months and the calibrations are traceable to NML/ROC and NIST/USA.  
2. The test was performed in HwaYa Chamber 4.  
3. The horn antenna and preamplifier (model: 8449B) are used only for the measurement of emission frequency above 1GHz if tested.  
4. The FCC Site Registration No. is 460141.  
5. The IC Site Registration No. is IC7450F-4.

#### 4.1.3 Test Procedures

- a. The EUT was placed on the top of a rotating table 0.8 meters (for below 1GHz) / 1.5 meters (for above 1GHz) above the ground at 3 meter chamber room for test. The table was rotated 360 degrees to determine the position of the highest radiation.
- b. The EUT was set 3 meters away from the interference-receiving antenna, which was mounted on the top of a variable-height antenna tower.
- c. The height of antenna is varied from one meter to four meters above the ground to determine the maximum value of the field strength. Both horizontal and vertical polarizations of the antenna are set to make the measurement.
- d. For each suspected emission, the EUT was arranged to its worst case and then the antenna was tuned to heights from 1 meter to 4 meters and the rotatable table was turned from 0 degrees to 360 degrees to find the maximum reading.
- e. The test-receiver system was set to quasi-peak detect function and specified bandwidth with maximum hold mode when the test frequency is below 1 GHz.
- f. The test-receiver system was set to peak and average detect function and specified bandwidth with maximum hold mode when the test frequency is above 1 GHz. If the peak reading value also meets average limit, measurement with the average detector is unnecessary.

Note:

1. The resolution bandwidth and video bandwidth of test receiver/spectrum analyzer is 120kHz for Quasi-peak detection (QP) at frequency below 1GHz.
2. The resolution bandwidth of test receiver/spectrum analyzer is 1 MHz and the video bandwidth is 3 MHz for Peak detection (PK) at frequency above 1GHz.
3. The resolution bandwidth of test receiver/spectrum analyzer is 1MHz and the video bandwidth is 3MHz for RMS Average (Duty cycle < 98%) for Average detection (AV) at frequency above 1GHz, then the measurement results was added to a correction factor ( $10 \log(1/\text{duty cycle})$ ).
4. The resolution bandwidth of test receiver/spectrum analyzer is 1MHz and the video bandwidth is 10Hz (Duty cycle  $\geq 98\%$ ) for Average detection (AV) at frequency above 1GHz.
5. All modes of operation were investigated and the worst-case emissions are reported.

#### 4.1.4 Deviation from Test Standard

No deviation.

#### 4.1.5 Test Set Up

<Frequency Range 30MHz~1GHz>

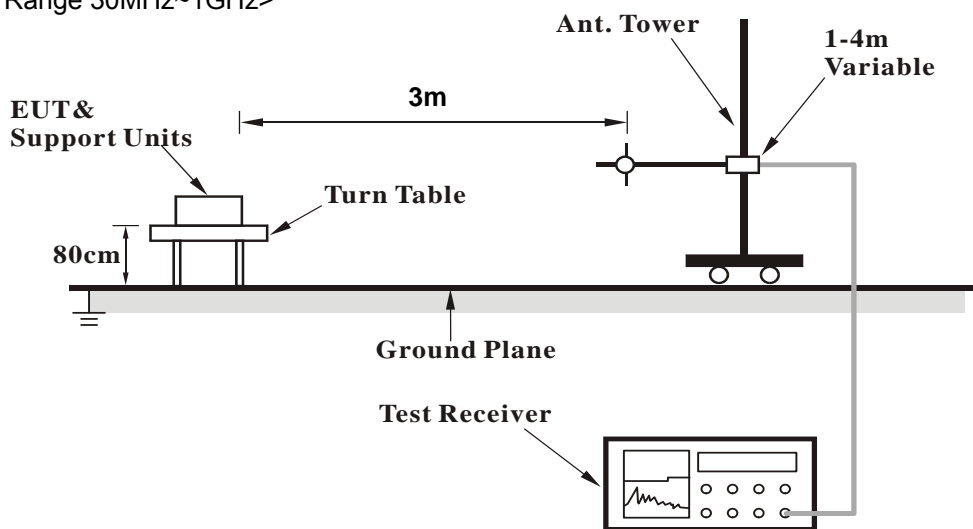

<Frequency Range above 1GHz>

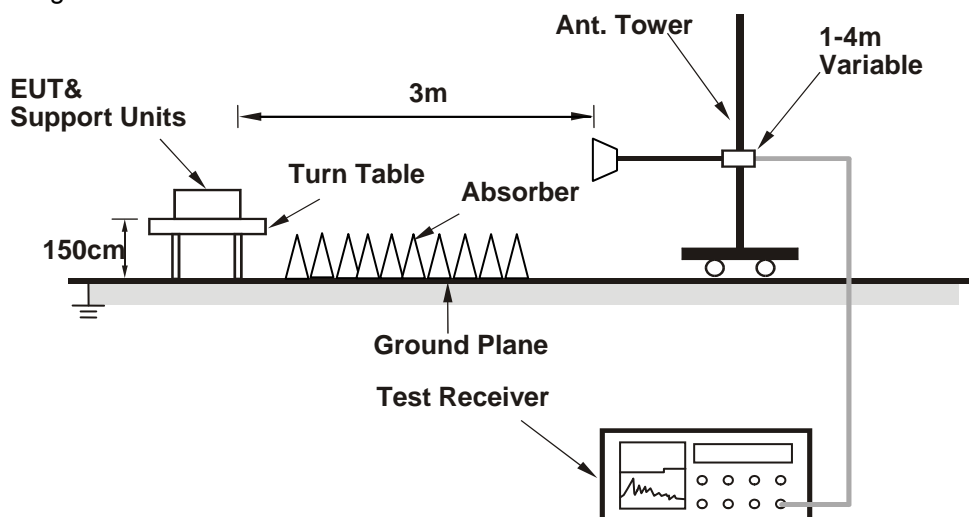

For the actual test configuration, please refer to the attached file (Test Setup Photo).

#### 4.1.6 EUT Operating Conditions

- a. Set the EUT under transmission condition continuously at specific channel frequency.

#### 4.1.7 Test Results

##### Above 1GHz Data

CHANNEL	TX Channel 0	DETECTOR FUNCTION	Peak (PK)
FREQUENCY RANGE	1GHz ~ 25GHz		Average (AV)

ANTENNA POLARITY & TEST DISTANCE: HORIZONTAL AT 3 M								
NO.	FREQ. (MHz)	EMISSION LEVEL (dBuV/m)	LIMIT (dBuV/m)	MARGIN (dB)	ANTENNA HEIGHT (m)	TABLE ANGLE (Degree)	RAW VALUE (dBuV)	CORRECTION FACTOR (dB/m)
1	2390.00	54.8 PK	74.0	-19.2	1.23 H	342	22.90	31.90
2	2390.00	44.8 AV	54.0	-9.2	1.23 H	342	12.90	31.90
3	*2402.00	82.0 PK			1.23 H	342	49.90	32.10
4	*2402.00	81.4 AV			1.23 H	342	49.30	32.10
5	4804.00	58.5 PK	74.0	-15.5	1.78 H	301	52.00	6.50
<b>6</b>	<b>4804.00</b>	<b>53.9 AV</b>	<b>54.0</b>	<b>-0.1</b>	<b>1.78 H</b>	<b>301</b>	<b>47.40</b>	<b>6.50</b>

ANTENNA POLARITY & TEST DISTANCE: VERTICAL AT 3 M								
NO.	FREQ. (MHz)	EMISSION LEVEL (dBuV/m)	LIMIT (dBuV/m)	MARGIN (dB)	ANTENNA HEIGHT (m)	TABLE ANGLE (Degree)	RAW VALUE (dBuV)	CORRECTION FACTOR (dB/m)
1	2390.00	54.9 PK	74.0	-19.1	1.05 V	114	23.00	31.90
2	2390.00	43.9 AV	54.0	-10.1	1.05 V	114	12.00	31.90
3	*2402.00	75.3 PK			1.00 V	109	43.20	32.10
4	*2402.00	74.6 AV			1.00 V	109	42.50	32.10
5	4804.00	54.6 PK	74.0	-19.4	1.00 V	267	48.10	6.50
6	4804.00	49.5 AV	54.0	-4.5	1.00 V	267	43.00	6.50

##### Remarks:

1. Emission Level(dBuV/m) = Raw Value(dBuV) + Correction Factor(dB/m)
2. Correction Factor(dB/m) = Antenna Factor(dB/m) + Cable Factor(dB)
3. The other emission levels were very low against the limit.
4. Margin value = Emission Level – Limit value
5. " \* ": Fundamental frequency.



CHANNEL	TX Channel 19	DETECTOR FUNCTION	Peak (PK)
FREQUENCY RANGE	1GHz ~ 25GHz		Average (AV)

**ANTENNA POLARITY & TEST DISTANCE: HORIZONTAL AT 3 M**

NO.	FREQ. (MHz)	EMISSION LEVEL (dBuV/m)	LIMIT (dBuV/m)	MARGIN (dB)	ANTENNA HEIGHT (m)	TABLE ANGLE (Degree)	RAW VALUE (dBuV)	CORRECTION FACTOR (dB/m)
1	*2440.00	82.7 PK			1.54 H	338	50.50	32.20
2	*2440.00	81.0 AV			1.54 H	338	48.80	32.20
3	4880.00	57.3 PK	74.0	-16.7	1.09 H	299	50.70	6.60
4	4880.00	53.6 AV	54.0	-0.4	1.09 H	299	47.00	6.60

**ANTENNA POLARITY & TEST DISTANCE: VERTICAL AT 3 M**

NO.	FREQ. (MHz)	EMISSION LEVEL (dBuV/m)	LIMIT (dBuV/m)	MARGIN (dB)	ANTENNA HEIGHT (m)	TABLE ANGLE (Degree)	RAW VALUE (dBuV)	CORRECTION FACTOR (dB/m)
1	*2440.00	75.4 PK			1.00 V	82	43.20	32.20
2	*2440.00	74.6 AV			1.00 V	82	42.40	32.20
3	4880.00	55.6 PK	74.0	-18.4	1.00 V	217	49.00	6.60
4	4880.00	50.9 AV	54.0	-3.1	1.00 V	217	44.30	6.60

**Remarks:**

1. Emission Level(dBuV/m) = Raw Value(dBuV) + Correction Factor(dB/m)
2. Correction Factor(dB/m) = Antenna Factor(dB/m) + Cable Factor(dB)
3. The other emission levels were very low against the limit.
4. Margin value = Emission Level – Limit value
5. " \* ": Fundamental frequency.

CHANNEL	TX Channel 39	DETECTOR FUNCTION	Peak (PK)
FREQUENCY RANGE	1GHz ~ 25GHz		Average (AV)

**ANTENNA POLARITY & TEST DISTANCE: HORIZONTAL AT 3 M**

NO.	FREQ. (MHz)	EMISSION LEVEL (dBuV/m)	LIMIT (dBuV/m)	MARGIN (dB)	ANTENNA HEIGHT (m)	TABLE ANGLE (Degree)	RAW VALUE (dBuV)	CORRECTION FACTOR (dB/m)
1	*2480.00	83.1 PK			1.03 H	337	50.70	32.40
2	*2480.00	82.5 AV			1.03 H	337	50.10	32.40
3	2483.50	56.2 PK	74.0	-17.8	1.14 H	340	23.80	32.40
4	2483.50	44.0 AV	54.0	-10.0	1.14 H	340	11.60	32.40
5	4960.00	57.8 PK	74.0	-16.2	1.61 H	358	51.00	6.80
6	4960.00	53.7 AV	54.0	-0.3	1.61 H	358	46.90	6.80

**ANTENNA POLARITY & TEST DISTANCE: VERTICAL AT 3 M**

NO.	FREQ. (MHz)	EMISSION LEVEL (dBuV/m)	LIMIT (dBuV/m)	MARGIN (dB)	ANTENNA HEIGHT (m)	TABLE ANGLE (Degree)	RAW VALUE (dBuV)	CORRECTION FACTOR (dB/m)
1	*2480.00	75.0 PK			1.28 V	121	42.60	32.40
2	*2480.00	74.2 AV			1.28 V	121	41.80	32.40
3	2483.50	55.9 PK	74.0	-18.1	1.30 V	125	23.50	32.40
4	2483.50	43.9 AV	54.0	-10.1	1.30 V	125	11.50	32.40
5	4960.00	54.6 PK	74.0	-19.4	1.01 V	122	47.80	6.80
6	4960.00	49.2 AV	54.0	-4.8	1.01 V	122	42.40	6.80

**Remarks:**

1. Emission Level(dBuV/m) = Raw Value(dBuV) + Correction Factor(dB/m)
2. Correction Factor(dB/m) = Antenna Factor(dB/m) + Cable Factor(dB)
3. The other emission levels were very low against the limit.
4. Margin value = Emission Level – Limit value
5. " \* ": Fundamental frequency.

Below 1GHz worst-case data:

CHANNEL	TX Channel 0	DETECTOR FUNCTION	Quasi-Peak (QP)
FREQUENCY RANGE	30MHz ~ 1GHz		
TEST MODE	A		

**ANTENNA POLARITY & TEST DISTANCE: HORIZONTAL AT 3 M**

NO.	FREQ. (MHz)	EMISSION LEVEL (dBuV/m)	LIMIT (dBuV/m)	MARGIN (dB)	ANTENNA HEIGHT (m)	TABLE ANGLE (Degree)	RAW VALUE (dBuV)	CORRECTION FACTOR (dB/m)
1	52.86	28.0 QP	40.0	-12.0	1.50 H	144	42.0	-14.0
2	320.40	40.1 QP	46.0	-5.9	1.00 H	247	51.9	-11.8
3	481.08	33.5 QP	46.0	-12.5	1.50 H	147	42.5	-9.0
4	599.98	42.2 QP	46.0	-3.8	1.00 H	300	48.4	-6.2
5	750.14	41.9 QP	46.0	-4.1	1.25 H	128	44.9	-3.0
6	874.47	41.1 QP	46.0	-4.9	1.00 H	187	42.3	-1.2

**ANTENNA POLARITY & TEST DISTANCE: VERTICAL AT 3 M**

NO.	FREQ. (MHz)	EMISSION LEVEL (dBuV/m)	LIMIT (dBuV/m)	MARGIN (dB)	ANTENNA HEIGHT (m)	TABLE ANGLE (Degree)	RAW VALUE (dBuV)	CORRECTION FACTOR (dB/m)
1	46.97	32.4 QP	40.0	-7.6	2.00 V	144	46.6	-14.2
2	320.41	33.5 QP	46.0	-12.5	1.00 V	214	45.3	-11.8
3	374.51	35.7 QP	46.0	-10.3	1.50 V	110	46.6	-10.9
4	624.41	40.3 QP	46.0	-5.7	1.00 V	155	45.9	-5.6
5	750.56	33.5 QP	46.0	-12.5	1.50 V	150	36.5	-3.0
6	874.47	37.9 QP	46.0	-8.1	1.25 V	258	39.1	-1.2

Remarks:

1. Emission Level(dBuV/m) = Raw Value(dBuV) + Correction Factor(dB/m)
2. Correction Factor(dB/m) = Antenna Factor(dB/m) + Cable Factor(dB)
3. The other emission levels were very low against the limit.
4. Margin value = Emission Level – Limit value

CHANNEL	TX Channel 0	DETECTOR FUNCTION	Quasi-Peak (QP)
FREQUENCY RANGE	30MHz ~ 1GHz		
TEST MODE	B		

**ANTENNA POLARITY & TEST DISTANCE: HORIZONTAL AT 3 M**

NO.	FREQ. (MHz)	EMISSION LEVEL (dBuV/m)	LIMIT (dBuV/m)	MARGIN (dB)	ANTENNA HEIGHT (m)	TABLE ANGLE (Degree)	RAW VALUE (dBuV)	CORRECTION FACTOR (dB/m)
1	49.30	24.1 QP	40.0	-15.9	1.00 H	298	38.1	-14.0
2	280.21	33.8 QP	46.0	-12.2	1.25 H	329	46.7	-12.9
3	319.02	38.6 QP	46.0	-7.4	2.00 H	323	50.4	-11.8
4	600.38	42.5 QP	46.0	-3.5	1.00 H	56	48.7	-6.2
5	749.79	40.6 QP	46.0	-5.4	2.00 H	133	43.6	-3.0
6	875.91	38.4 QP	46.0	-7.6	1.50 H	229	39.6	-1.2

**ANTENNA POLARITY & TEST DISTANCE: VERTICAL AT 3 M**

NO.	FREQ. (MHz)	EMISSION LEVEL (dBuV/m)	LIMIT (dBuV/m)	MARGIN (dB)	ANTENNA HEIGHT (m)	TABLE ANGLE (Degree)	RAW VALUE (dBuV)	CORRECTION FACTOR (dB/m)
1	45.42	31.0 QP	40.0	-9.0	1.25 V	10	45.4	-14.4
2	319.02	30.6 QP	46.0	-15.4	1.00 V	205	42.4	-11.8
3	375.29	36.1 QP	46.0	-9.9	2.00 V	144	47.0	-10.9
4	625.60	40.2 QP	46.0	-5.8	1.50 V	210	45.8	-5.6
5	749.79	33.2 QP	46.0	-12.8	1.25 V	51	36.2	-3.0
6	875.91	38.1 QP	46.0	-7.9	1.00 V	30	39.3	-1.2

**Remarks:**

1. Emission Level(dBuV/m) = Raw Value(dBuV) + Correction Factor(dB/m)
2. Correction Factor(dB/m) = Antenna Factor(dB/m) + Cable Factor(dB)
3. The other emission levels were very low against the limit.
4. Margin value = Emission Level – Limit value

## 4.2 Conducted Emission Measurement

### 4.2.1 Limits of Conducted Emission Measurement

Frequency (MHz)	Conducted Limit (dBuV)	
	Quasi-peak	Average
0.15 - 0.5	66 - 56	56 - 46
0.50 - 5.0	56	46
5.0 - 30.0	60	50

Note: 1. The lower limit shall apply at the transition frequencies.  
 2. The limit decreases in line with the logarithm of the frequency in the range of 0.15 to 0.50MHz.

### 4.2.2 Test Instruments

Description & Manufacturer	Model No.	Serial No.	Cal. Date	Cal. Due
Test Receiver ROHDE & SCHWARZ	ESCI	100613	Nov. 16, 2015	Nov. 15, 2016
RF signal cable (with 10dB PAD) Woken	5D-FB	Cable-cond1-01	Dec. 26, 2015	Dec. 25, 2016
LISN ROHDE & SCHWARZ (EUT)	ESH3-Z5	835239/001	Feb. 26, 2016	Feb. 25, 2017
LISN ROHDE & SCHWARZ (Peripheral)	ESH3-Z5	100220	Nov. 13, 2015	Nov. 12, 2016
Software ADT	BV ADT_Cond_ V7.3.7.3	NA	NA	NA

Note: 1. The calibration interval of the above test instruments is 12 months and the calibrations are traceable to NML/ROC and NIST/USA.  
 2. The test was performed in HwaYa Shielded Room 1.  
 3. The VCCI Site Registration No. is C-2040.

### 4.2.3 Test Procedures

- The EUT was placed 0.4 meters from the conducting wall of the shielded room with EUT being connected to the power mains through a line impedance stabilization network (LISN). Other support units were connected to the power mains through another LISN. The two LISNs provide 50 ohm/ 50uH of coupling impedance for the measuring instrument.
- Both lines of the power mains connected to the EUT were checked for maximum conducted interference.
- The frequency range from 150kHz to 30MHz was searched. Emission levels under (Limit - 20dB) was not recorded.

**NOTE:** All modes of operation were investigated and the worst-case emissions are reported.

### 4.2.4 Deviation from Test Standard

No deviation.

### 4.2.5 Test Setup

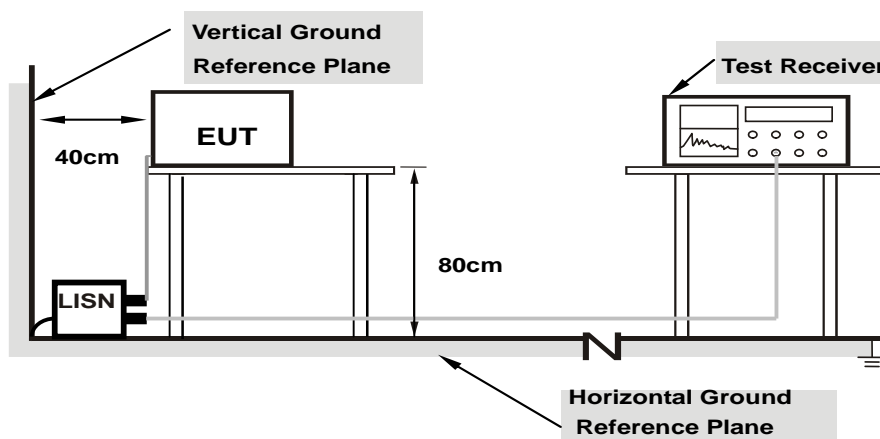

**Note:** 1.Support units were connected to second LISN.

For the actual test configuration, please refer to the attached file (Test Setup Photo).

### 4.2.6 EUT Operating Conditions

Same as 4.1.6.

### 4.2.7 Test Results

Phase	Line (L)	Detector Function	Quasi-Peak (QP) / Average (AV)
Test Mode	A		

No	Freq. [MHz]	Corr. Factor (dB)	Reading Value [dB (uV)]		Emission Level [dB (uV)]		Limit [dB (uV)]		Margin (dB)	
			Q.P.	AV.	Q.P.	AV.	Q.P.	AV.	Q.P.	AV.
			1	0.20469	10.16	26.86	12.37	37.02	22.53	63.42
2	0.47422	10.19	19.83	13.40	30.02	23.59	56.44	46.44	-26.42	-22.85
3	1.41016	10.24	5.03	-1.43	15.27	8.81	56.00	46.00	-40.73	-37.19
4	3.34375	10.33	17.70	7.15	28.03	17.48	56.00	46.00	-27.97	-28.52
5	11.57031	10.50	17.58	12.12	28.08	22.62	60.00	50.00	-31.92	-27.38
6	17.26563	10.57	13.42	9.11	23.99	19.68	60.00	50.00	-36.01	-30.32

REMARKS:

1. Q.P. and AV. are abbreviations of quasi-peak and average individually.
2. The emission levels of other frequencies were very low against the limit.
3. Margin value = Emission level - Limit value
4. Correction factor = Insertion loss + Cable loss
5. Emission Level = Correction Factor + Reading Value.

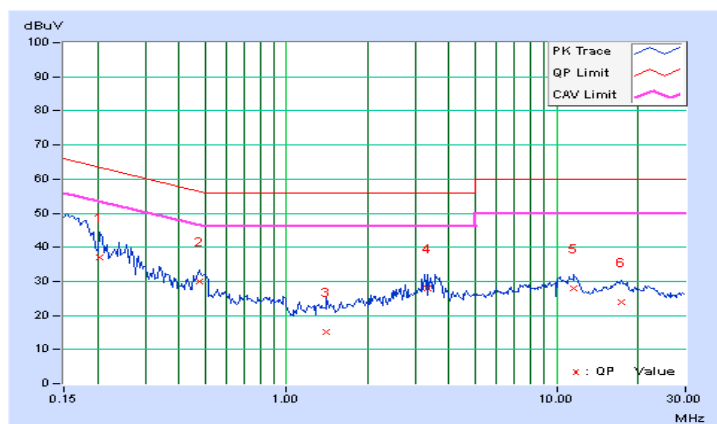

Phase	Neutral (N)	Detector Function	Quasi-Peak (QP) / Average (AV)
Test Mode	A		

No	Freq. [MHz]	Corr. Factor (dB)	Reading Value [dB (uV)]		Emission Level [dB (uV)]		Limit [dB (uV)]		Margin (dB)	
			Q.P.	AV.	Q.P.	AV.	Q.P.	AV.	Q.P.	AV.
			1	0.16953	10.14	34.00	21.53	44.14	31.67	64.98
2	0.20469	10.16	26.35	11.91	36.51	22.07	63.42	53.42	-26.91	-31.35
3	0.43125	10.19	13.27	7.24	23.46	17.43	57.23	47.23	-33.77	-29.80
4	3.62891	10.37	17.73	7.02	28.10	17.39	56.00	46.00	-27.90	-28.61
5	11.25781	10.58	16.30	10.88	26.88	21.46	60.00	50.00	-33.12	-28.54
6	19.75000	10.78	4.20	-0.65	14.98	10.13	60.00	50.00	-45.02	-39.87

**REMARKS:**

1. Q.P. and AV. are abbreviations of quasi-peak and average individually.
2. The emission levels of other frequencies were very low against the limit.
3. Margin value = Emission level - Limit value
4. Correction factor = Insertion loss + Cable loss
5. Emission Level = Correction Factor + Reading Value.

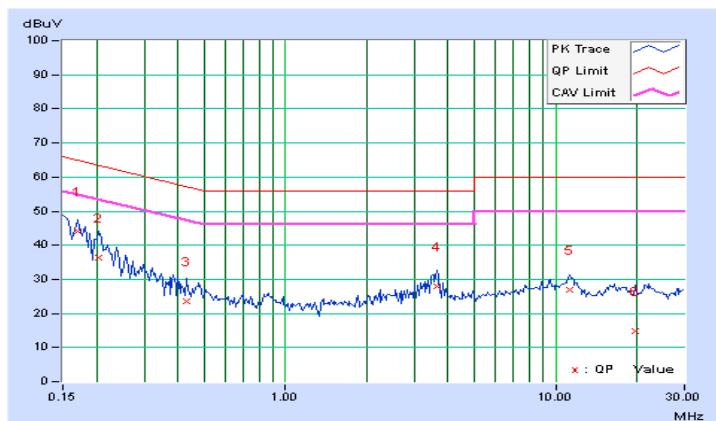



Phase	Line (L)	Detector Function	Quasi-Peak (QP) / Average (AV)
Test Mode	B		

No	Freq. [MHz]	Corr. Factor (dB)	Reading Value [dB (uV)]		Emission Level [dB (uV)]		Limit [dB (uV)]		Margin (dB)	
			Q.P.	AV.	Q.P.	AV.	Q.P.	AV.	Q.P.	AV.
			1	0.18906	10.15	28.40	12.31	38.55	22.46	64.08
<b>2</b>	<b>0.48203</b>	<b>10.19</b>	<b>20.72</b>	<b>17.34</b>	<b>30.91</b>	<b>27.53</b>	<b>56.30</b>	<b>46.30</b>	<b>-25.39</b>	<b>-18.77</b>
3	1.23047	10.23	4.18	-2.82	14.41	7.41	56.00	46.00	-41.59	-38.59
4	3.48828	10.33	18.76	7.69	29.09	18.02	56.00	46.00	-26.91	-27.98
5	11.63672	10.50	16.11	11.28	26.61	21.78	60.00	50.00	-33.39	-28.22
6	21.83203	10.58	11.35	6.37	21.93	16.95	60.00	50.00	-38.07	-33.05

REMARKS:

1. Q.P. and AV. are abbreviations of quasi-peak and average individually.
2. The emission levels of other frequencies were very low against the limit.
3. Margin value = Emission level - Limit value
4. Correction factor = Insertion loss + Cable loss
5. Emission Level = Correction Factor + Reading Value.

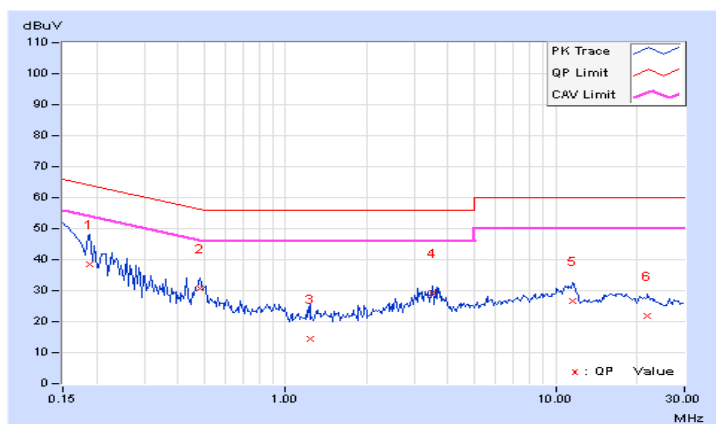

Phase	Neutral (N)	Detector Function	Quasi-Peak (QP) / Average (AV)
Test Mode	B		

No	Freq. [MHz]	Corr. Factor (dB)	Reading Value [dB (uV)]		Emission Level [dB (uV)]		Limit [dB (uV)]		Margin (dB)	
			Q.P.	AV.	Q.P.	AV.	Q.P.	AV.	Q.P.	AV.
			1	0.18516	10.15	28.87	13.43	39.02	23.58	64.25
2	0.44297	10.19	9.18	4.18	19.37	14.37	57.01	47.01	-37.64	-32.64
3	0.83750	10.20	7.35	0.89	17.55	11.09	56.00	46.00	-38.45	-34.91
4	3.48438	10.37	18.11	6.93	28.48	17.30	56.00	46.00	-27.52	-28.70
5	11.74609	10.59	17.23	11.18	27.82	21.77	60.00	50.00	-32.18	-28.23
6	17.73438	10.73	11.25	6.73	21.98	17.46	60.00	50.00	-38.02	-32.54

REMARKS:

1. Q.P. and AV. are abbreviations of quasi-peak and average individually.
2. The emission levels of other frequencies were very low against the limit.
3. Margin value = Emission level - Limit value
4. Correction factor = Insertion loss + Cable loss
5. Emission Level = Correction Factor + Reading Value.

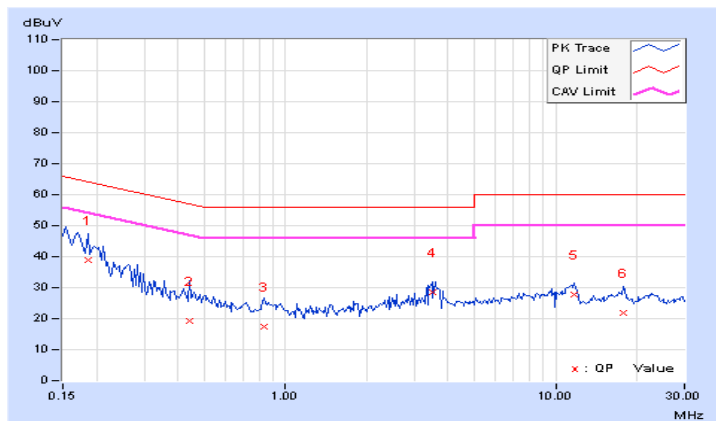

### 4.3 6dB Bandwidth Measurement

#### 4.3.1 Limits of 6dB Bandwidth Measurement

The minimum of 6dB Bandwidth Measurement is 0.5 MHz.

#### 4.3.2 Test Setup

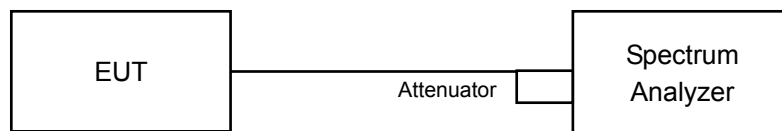

#### 4.3.3 Test Instruments

Refer to section 4.1.2 to get information of above instrument.

#### 4.3.4 Test Procedure

- Set resolution bandwidth (RBW) = 100kHz
- Set the video bandwidth (VBW)  $\geq 3 \times$  RBW, Detector = Peak.
- Trace mode = max hold.
- Sweep = auto couple.
- Measure the maximum width of the emission that is constrained by the frequencies associated with the two amplitude points (upper and lower) that are attenuated by 6 dB relative to the maximum level measured in the fundamental emission

#### 4.3.5 Deviation from Test Standard

No deviation.

#### 4.3.6 EUT Operating Conditions

The software provided by client to enable the EUT under transmission condition continuously at lowest, middle and highest channel frequencies individually.

### 4.3.7 Test Result

Channel	Frequency (MHz)	6dB Bandwidth (MHz)	Minimum Limit (MHz)	Pass / Fail
0	2402	0.51	0.5	Pass
19	2440	0.52	0.5	Pass
39	2480	0.52	0.5	Pass

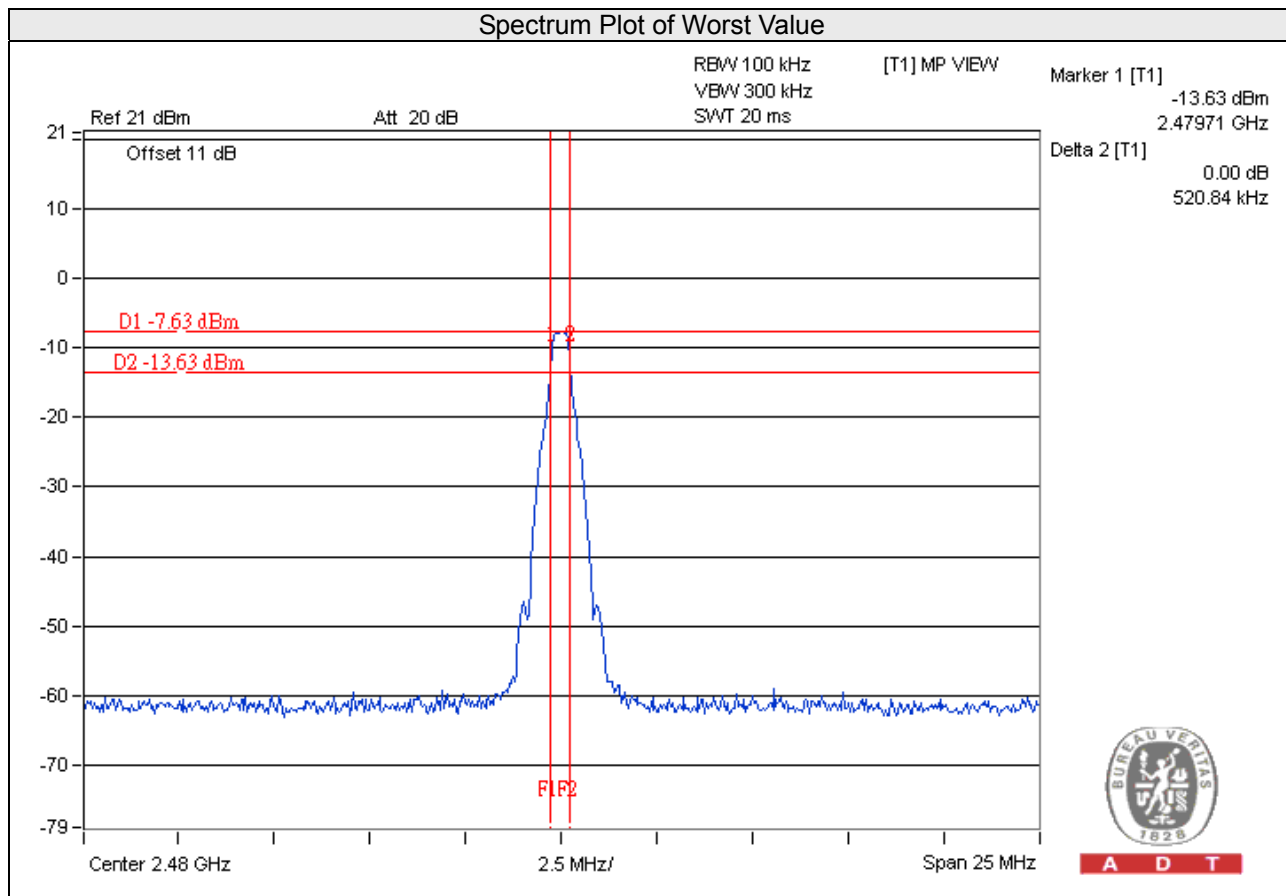

#### 4.4 Conducted Output Power Measurement

##### 4.4.1 Limits of Conducted Output Power Measurement

For systems using digital modulation in the 2400–2483.5 MHz bands: 1 Watt (30dBm)

##### 4.4.2 Test Setup

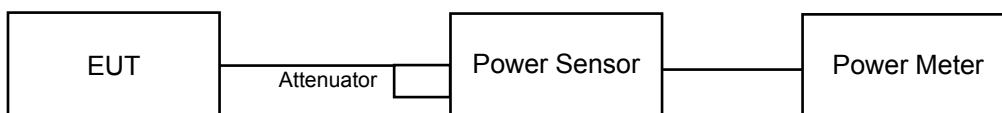

##### 4.4.3 Test Instruments

Refer to section 4.1.2 to get information of above instrument.

##### 4.4.4 Test Procedures

558074 D01 DTS Meas Guidance v03r05 section 9.2.3.2

A peak power sensor was used on the output port of the EUT. A power meter was used to read the response of the peak power sensor and set the detector to PEAK. Record the power level.

##### 4.4.5 Deviation from Test Standard

No deviation.

##### 4.4.6 EUT Operating Conditions

Same as 4.3.6.

##### 4.4.7 Test Results

Channel	Frequency (MHz)	Peak Power (mW)	Peak Power (dBm)	Limit (dBm)	Pass/Fail
0	2402	0.542	-2.66	30	Pass
19	2440	<b>0.551</b>	-2.59	30	Pass
39	2480	0.548	-2.61	30	Pass

## **4.5 Power Spectral Density Measurement**

### **4.5.1 Limits of Power Spectral Density Measurement**

The Maximum of Power Spectral Density Measurement is 8dBm.

### **4.5.2 Test Setup**

Same as 4.3.2

### **4.5.3 Test Instruments**

Refer to section 4.1.2 to get information of above instrument.

### **4.5.4 Test Procedure**

- a. Set analyzer center frequency to DTS channel center frequency.
- b. Set the span to 1.5 times the DTS bandwidth.
- c. Set the RBW to:  $3 \text{ kHz} \leq \text{RBW} \leq 100 \text{ kHz}$ .
- d. Set the VBW  $\geq 3 \times \text{RBW}$ .
- e. Detector = peak.
- f. Sweep time = auto couple.
- g. Trace mode = max hold.
- h. Allow trace to fully stabilize.
- i. Use the peak marker function to determine the maximum amplitude level within the RBW.

### **4.5.5 Deviation from Test Standard**

No deviation.

### **4.5.6 EUT Operating Condition**

Same as 4.3.6

### 4.5.7 Test Results

Channel	Freq. (MHz)	PSD (dBm)	Limit (dBm)	Pass / Fail
0	2402	-19.16	8	Pass
19	2440	-18.51	8	Pass
39	2480	-17.94	8	Pass

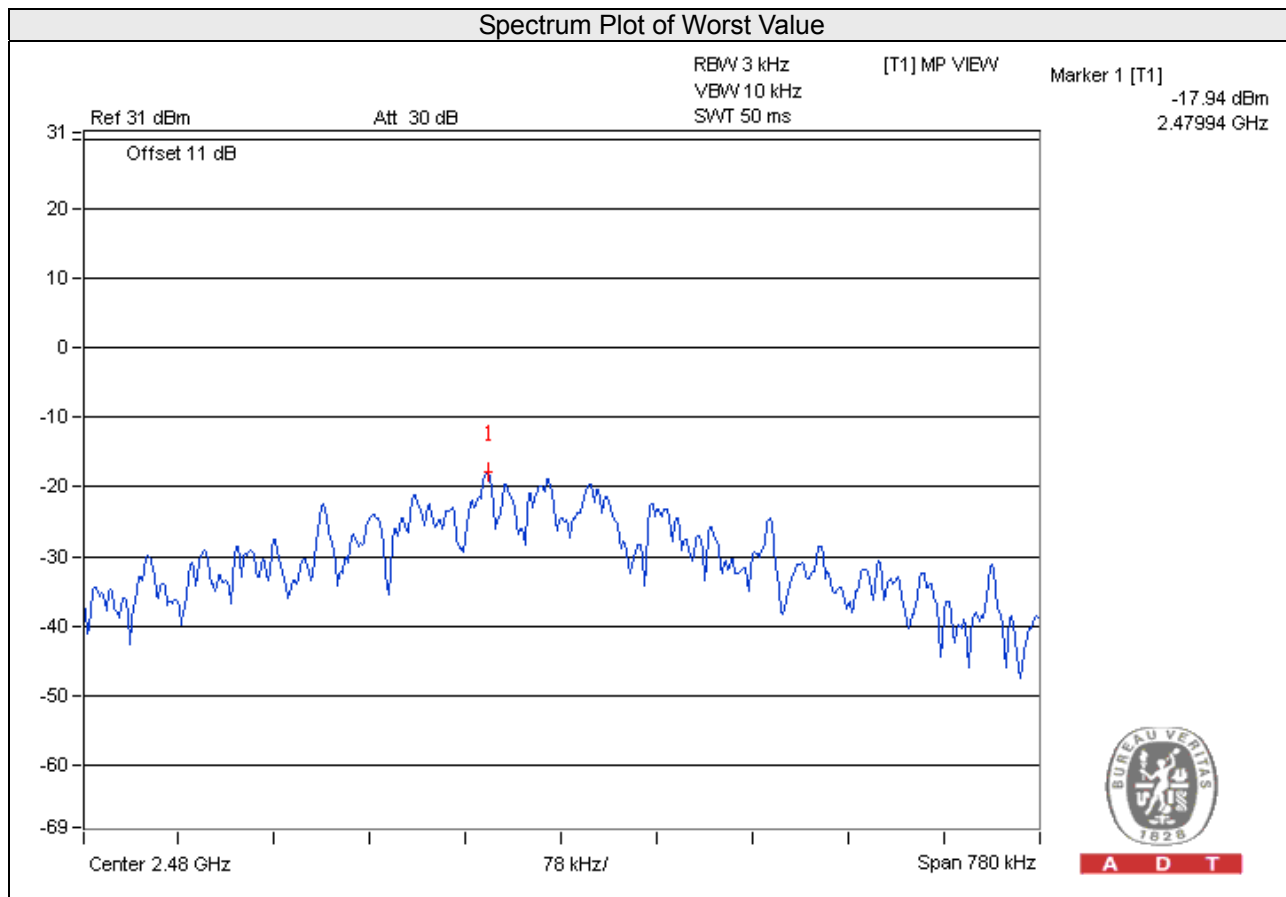

## 4.6 Conducted Out of Band Emission Measurement

### 4.6.1 Limits of Conducted Out of Band Emission Measurement

Below -20dB of the highest emission level of operating band (in 100kHz Resolution Bandwidth).

### 4.6.2 Test Setup

Same as 4.3.2

### 4.6.3 Test Instruments

Refer to section 4.1.2 to get information of above instrument.

### 4.6.4 Test Procedure

#### Measurement Procedure REF

- a. Set the RBW = 100 kHz.
- b. Set the VBW  $\geq$  300 kHz.
- c. Detector = peak.
- d. Sweep time = auto couple.
- e. Trace mode = max hold.
- f. Allow trace to fully stabilize.
- g. Use the peak marker function to determine the maximum power level in any 100 kHz band segment within the fundamental EBW.

#### Measurement Procedure OOBE

- a. Set RBW = 100 kHz.
- b. Set VBW  $\geq$  300 kHz.
- c. Detector = peak.
- d. Sweep = auto couple.
- e. Trace Mode = max hold.
- f. Allow trace to fully stabilize.
- g. Use the peak marker function to determine the maximum amplitude level.

### 4.6.5 Deviation from Test Standard

No deviation.

### 4.6.6 EUT Operating Condition

Same as 4.3.6

### 4.6.7 Test Results

The spectrum plots are attached on the following pages. D1 line indicates the highest level, and D2 line indicates the 20dB offset below D1. It shows compliance with the requirement.



### CH 0

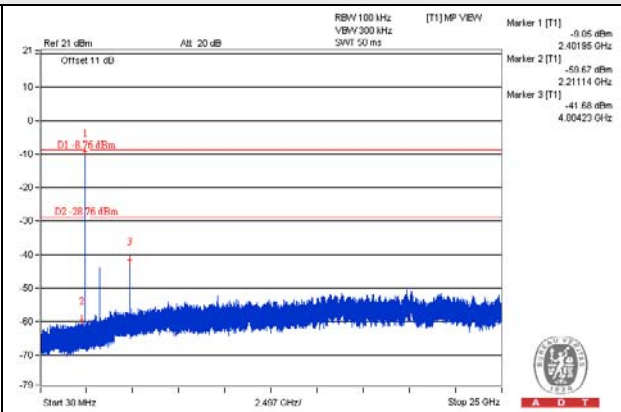
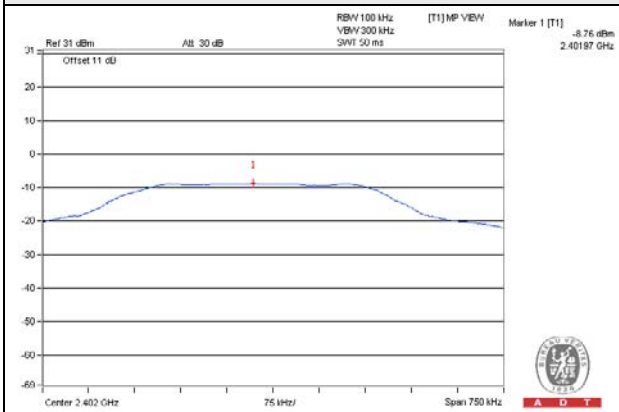

### CH 19

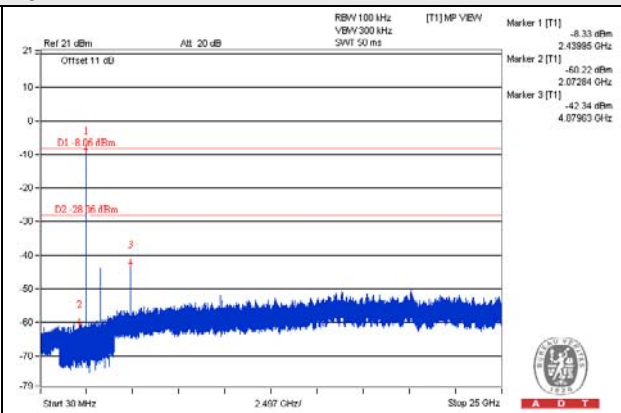
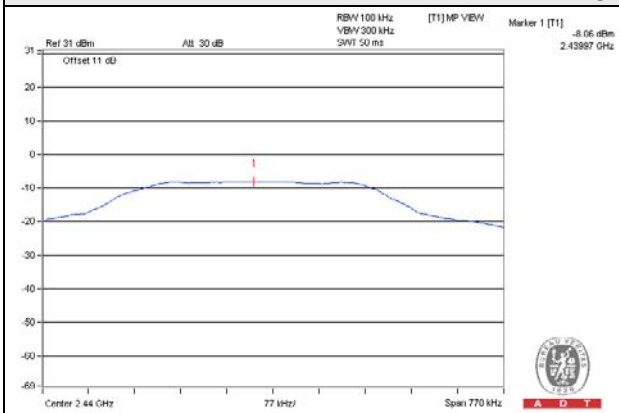

### CH 39

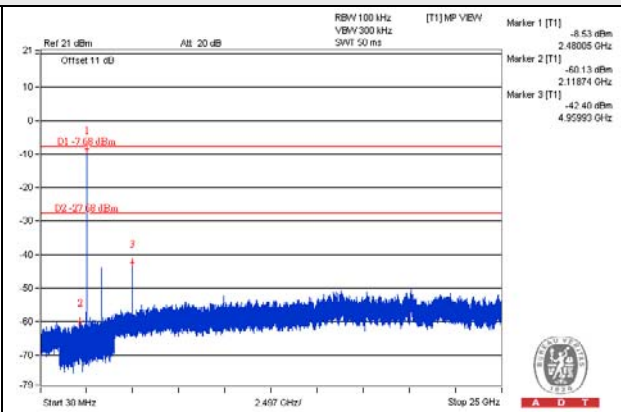
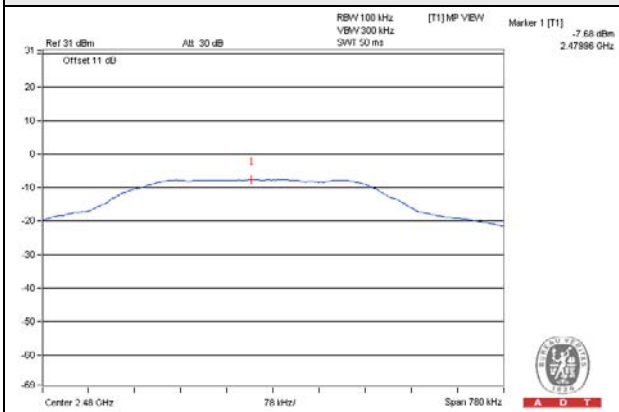

### CH 0 Band edge

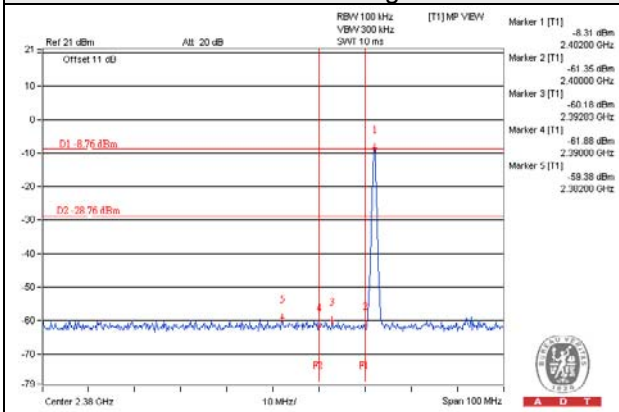

### CH 39 Band edge

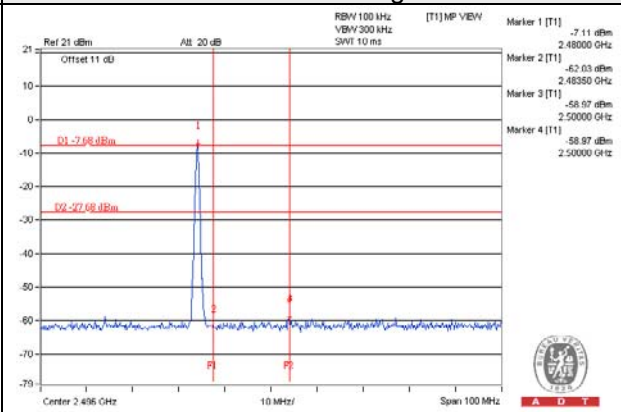

## 5 Pictures of Test Arrangements

Please refer to the attached file (Test Setup Photo).



## Appendix – Information on the Testing Laboratories

We, Bureau Veritas Consumer Products Services (H.K.) Ltd., Taoyuan Branch, were founded in 1988 to provide our best service in EMC, Radio, Telecom and Safety consultation. Our laboratories are accredited and approved according to ISO/IEC 17025.

If you have any comments, please feel free to contact us at the following:

**Linko EMC/RF Lab**

Tel: 886-2-26052180

Fax: 886-2-26051924

**Hsin Chu EMC/RF/Telecom Lab**

Tel: 886-3-6668565

Fax: 886-3-6668323

**Hwa Ya EMC/RF/Safety**

Tel: 886-3-3183232

Fax: 886-3-3270892

**Email:** [service.adt@tw.bureauveritas.com](mailto:service.adt@tw.bureauveritas.com)

**Web Site:** [www.bureauveritas-adt.com](http://www.bureauveritas-adt.com)

The address and road map of all our labs can be found in our web site also.

--- END ---