



















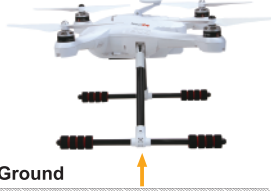

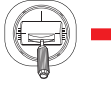



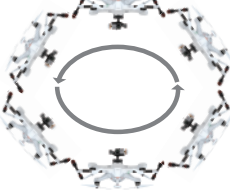

# 10.0 Operation Instruction

Model ( ← is the nose direction)	Mode 1	Mode 2
<b>THROTTLE</b> Up/down 		
<b>PITCH</b> Forward/backward Scout X4 nose move up/down 		
<b>ROLL (lean)</b> Left / right 		
<b>YAW (turn)</b> Left / right 		
<b>AUTO Take Off</b> You should have triple blink = 8sats for this feature. ARM/UNLOCK motors in manual mode 		   
<b>GPS hold mode</b> You can fly in this mode simply move the controls when you let go of the control, the Scout X4 will stop NOTE: You must CENTER the throttle stick for altitude hold 		  <p>DO NOT switch to manual before landing it is safer to land in GPS hold mode. switch to manual AFTER landing to lock motors</p>
<b>ROUND FLY mode</b> This mode is used for making circles around a object of interest. RADIUS is set in the F12E menu by adjusting Position 2 value for AUX3 		   <p>MIX switch to "1" position      Move FMOD switch to "2" The Round Fly will start      Move FMOD switch to "0" The Round Fly will stop</p>
<b>RETURN TO HOME</b> Activating this feature will casue the Scout X4 to climb to 15m at this height it will fly to the starting location and proceed to land. 		  <p>You can stop RTH by switching to GPS hold MAKE SURE the throttle stick is set to 50% when switching. NEVER switch to MANUAL from RTH, this can cause a crash.</p>

## 11.0 DEVO F12E Radio function setup and operation instructions

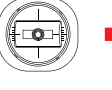
Function	Switch	Transmitter setting	Instructions
<b>AUTO Take Off</b>	<b>RUDD D/R</b>	Model Menu ↓ Device Output ↓ Flap ↓ RUDD D/R ↓ Active	Place aircraft on level ground → Unlock Motors → Move throttle stick to lowest position → Set MIX switch to "0" Position → Set RUDD D/R switch to "1" Position  <b>IMPORTANT:</b> ONLY use this function with BLUE TRIPLE blink = 8 or more satellites, AUTO take off with less satellites may result in a crash. AFTER completing auto-take-off, you can take control by moving the throttle stick to 50%, then flip the RUDD D/R switch to "0" position.
<b>GPS hold mode</b>	<b>MIX SW</b>	Model Menu ↓ Device Output ↓ Gear ↓ MIX SW ↓ Active	"0" position: Manual mode      "1" position: GPS hold mode "2" position: Return To Home MIX switch to "1" position → Throttle stick return neutral NEVER use this mode with less than 8 satellites locked, you should see BLUE TRIPLE BLINK. Before switching mode, always put the throttle stick to middle position ( 50% ). IF the GPS signal degrades, the X4 will automatically enter "Altitude hold mode" note in this mode it will drift, but will hold its altitude. After flying 50% of the battery, do NOT switch from GPS mode to Manual, this may cause a sudden drop / crash. You can land in GPS mode, after landing, keep the throttle stick DOWN and switch to manual, then lock the motors.
<b>Round Fly Mode</b>	<b>FMOD</b>	Model Menu ↓ Device Output ↓ AUX3 ↓ FMOD SW ↓ Active	"0" Position: OFF      "1" Position: Not in use "2" Position: activate Round Fly This mode require 8 satellites locked, you should see BLUE TRIPLE BLINK. Before activating the round-fly mode, you should be in "GPS hold mode" always put the throttle stick to middle position ( 50% ) The default roundfly radius is 5 meters (15 feet), You can change the Round Fly radius by editing the AUX 3 EPA (End Point Adjustment) on the F12E transmitter, for details on editing EPA settings, see the F12E instruction manual. After having changed the setting, you should turn FMOD switch to "0" position to save the data, then return to "2" position to read the new Roundly radius.
<b>Return TO Home</b>	<b>MIX SW</b>	Model Menu ↓ Device Output ↓ Gear ↓ MIX SW ↓ Active	"0" position: Manual mode      "1" position: GPS hold mode "2" position: Return To Home Throttle stick return neutral → MIX switch to "2" position The Return To Home mode, only work when you have a solid GPS lock, it is recommend to avoid flying if GPS lock is missing. After engaging Return to Home mode, lave the throttle stick at 50% (centered) do not touch any switches on the F12E radio. You can REGAIN control of the Scout X4, make sure the throttle is centered, then flip the MIX switch to "1" position. in a emergency like loss of control link between the F12e and the Scout X4, the Failsafe system will automatically start RTH, you may not be able to interupt a emergency RTH, simply let the aircraft continue until it lands.

Function	Switch	Transmitter setting	Instructions
<b>Hyper IOC Mode</b>	<b>ELEV D/R</b>	Model Menu ↓ Device Output ↓ AUX2 ↓ ELEV D/R ↓ Active	 <p>IOC or Intelligent Orientation Control mode Means the aircraft's flight direction is only relative to the original take-off point (where you armed the motors). REGARDLESS of the actual aircraft heading, with this mode you can fly past something and pan the aircraft to frame your shot, without having to worry what direction the aircraft is facing.</p> <p>ELEV D/R switch "0" position: IOC OFF      "1" position: IOC ON</p> <p>The IOC mode require a strong GPS lock, you should have triple blinks on the blue GPS indicator light.</p> <p>IOC is inactive if the Scout X4 is less than 10 meter (30 feet) from the original take-off position. (point where you armed the motors)</p> <p>Fly the Scout X4 manually to past 10 meters using the GPS mode, activate the IOC mode when you are past 10meters, the Scout X4 will now fly IOC until you change mode, you can pan freely for video shots, when you push the stick right or left, the Scout X4 will move sideways relative to the original take-off position. Pushing the pitch stick up will push the Scout X4 away from you, bulling the stick back, bring the Scout X4 back to the starting point. When flying in IOC mode, you can make the Scout X4 retun home by simply puling the PITCH stick down.</p> <p><b>WARNING:</b> The IOC turns off when the aircraft get closer than 10meters to the take off point, be prepared for this, as the system will switch back to GPS hold mode at that point. this switch can cause confusion if the pilot are not prepared.</p>
<b>Extend/Retract of Landing Gear</b>	<b>GEAR</b>	Model Menu ↓ Device Output ↓ AUX4 ↓ GEAR SW ↓ Active	<p>"0" Position: Extend landing Gear</p> <p>"1" Position: Retract landing Gear</p> <p><b>NOTE:</b> REMEMBER your landing gear, it is easy to forget the landing-gear when flying FPV. its not a good idea to land on your camera. When activating the RTH (Return To Home) system, either by the pilot of by the failsafe system.</p> <p>The Scout X4 will automatically extend the landing gear to protect your camera and make sure the Scout X4 land safely.</p> <p>You can not change the landing gear after the Scout X4 have automatically extended for landing. you must land and lock / unlock motors.</p>

## 12.0 DEVO F12E Radio Setting

### 12.1 Boot Screen(Main interface)

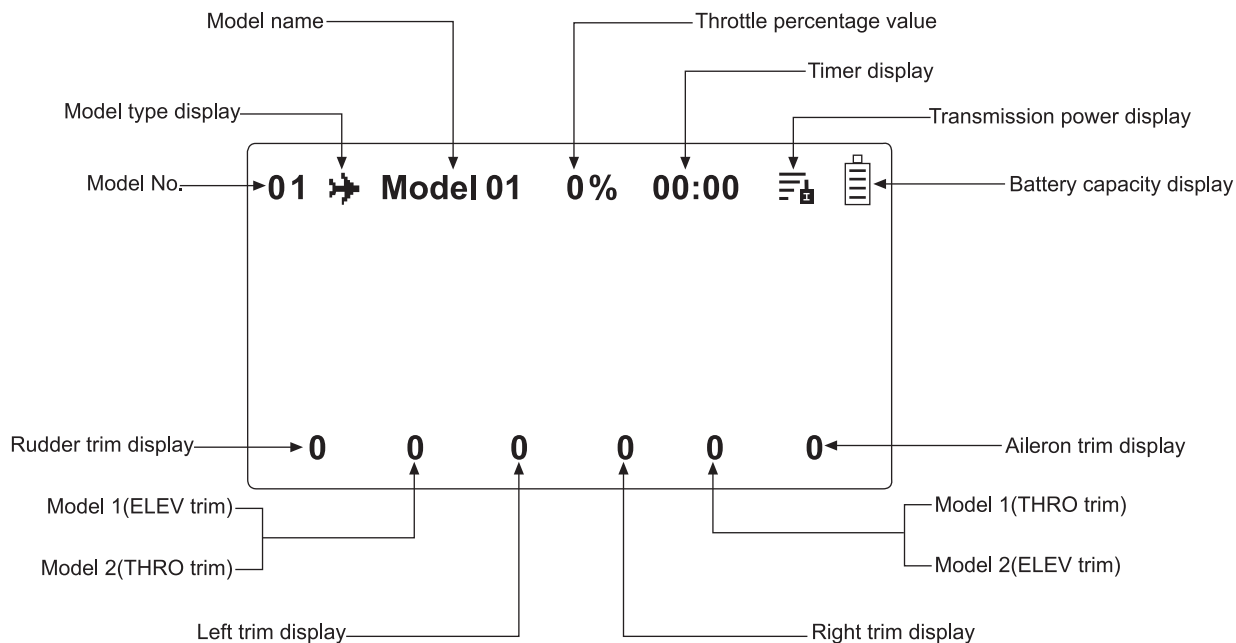

## 12.2 Model Select

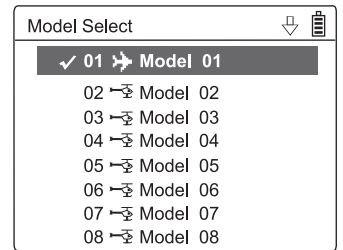

Press UP or DN button to select the stored model No. For example "Model 01", press EXT to return back "Model Menu" after finished.

## 12.3 Model Name

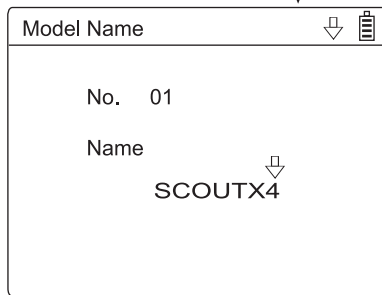
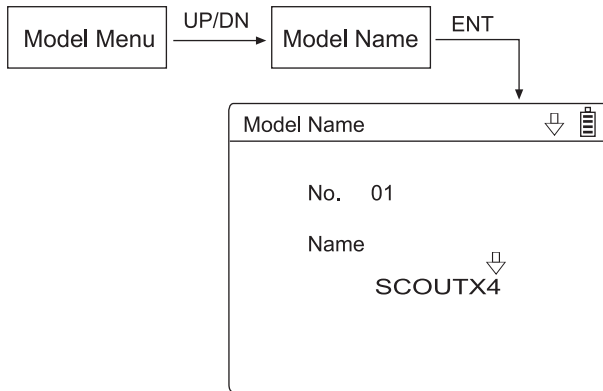

Press UP or DN button to select the characters which need to be changed, Named model as "SCOUTX4". Press EXT to return "Model Menu".

## 12.4 Type Select

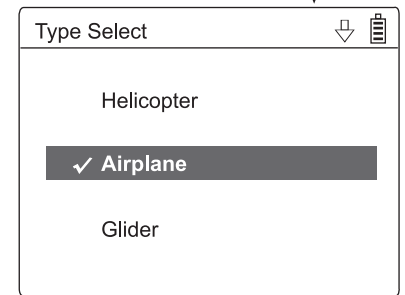
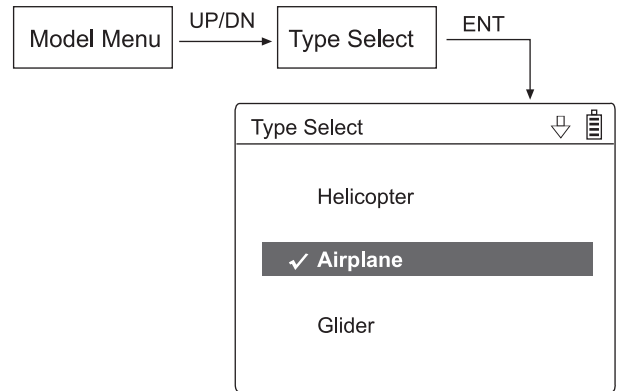

Select the model type by R or L button, and confirmed with ENT, once finished will return to "Model Menu" automatically

## 12.5 Wing Type

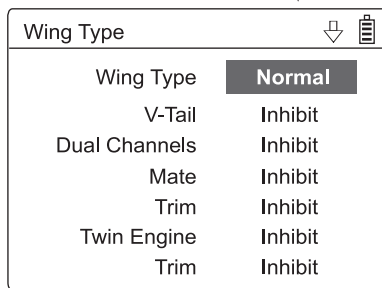
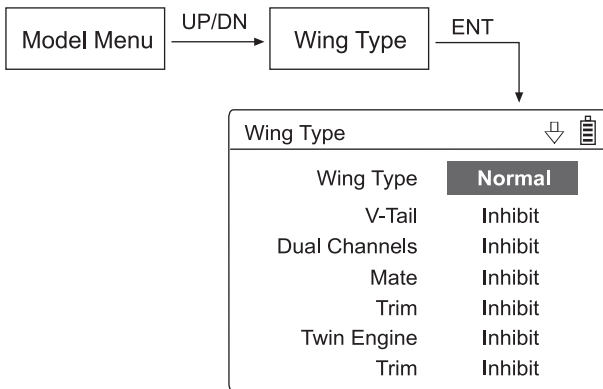

Press R or L to select "Normal", then press EXT to return "Model Menu".

## 12.6 Device Output

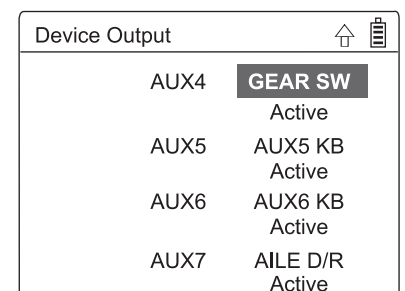
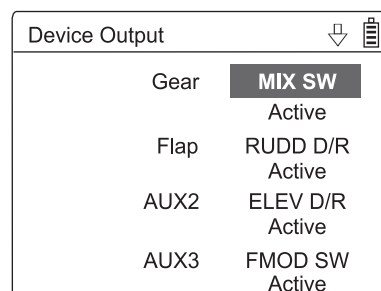
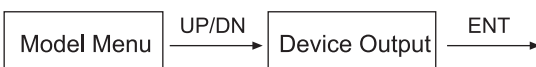

Press EXT to return back "Model Menu" after finished.

## 12.7 Sensor Setting

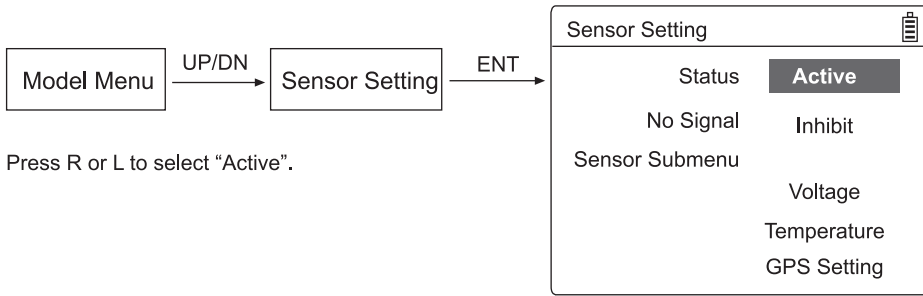

Press R or L to select "Active".

### (1) Voltage Setting

Press UP or DN to select Voltage in the Sensor Setting. Press ENT to enter Voltage interface.

Voltage	
Internal: V0	Inhibit
External: V1	Active
	<b>21.4V</b>
External: V2	Inhibit

Internal shows the Radio battery voltage.

External shows the aircraft battery voltage.

**Scout X4 default setting is 21.4V, please fly back the copter when you get a warning asap.**

### (2) GPS Receive Setting

Press UP or DN to select GPS setting on the Sensor Setting interface, then press ENT to enter GPS Setting interface.

GPS Setting	
Altitude Type	<b>Relative</b>
Speed Unit	Km/h
Date Type	DD-MM-YY
Time Zone	UTC+08:00

(2.1) Altitude Type setting:

Press R or L to select Absolute or Relative.

(2.2) Speed Unit setting:

Press R or L to select Km/h or Knot.

### (2.3) Date Type setting:

Press R or L to select DD-MM-YY\ MM-DD-YY\ YY-MM-DD.

### (2.4) Time Zone:

Press R or L to select Time Zone, then press EXT to return "Main Menu".

## 12.8 Reverse Switch

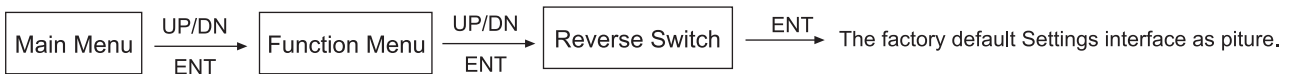

Reverse Switch	
Elevator	<b>Normal</b>
Aileron	Normal
Throttle	Normal
Rudder	Normal
Gear	Normal
Flap	Normal
AUX2	Normal
AUX3	Normal

Reverse Switch	
AUX4	<b>Normal</b>
AUX5	Normal
AUX6	Normal
AUX7	Normal

Press EXT to return back "Function Menu" after finished.

## 12.9 Servo Travel Adjust

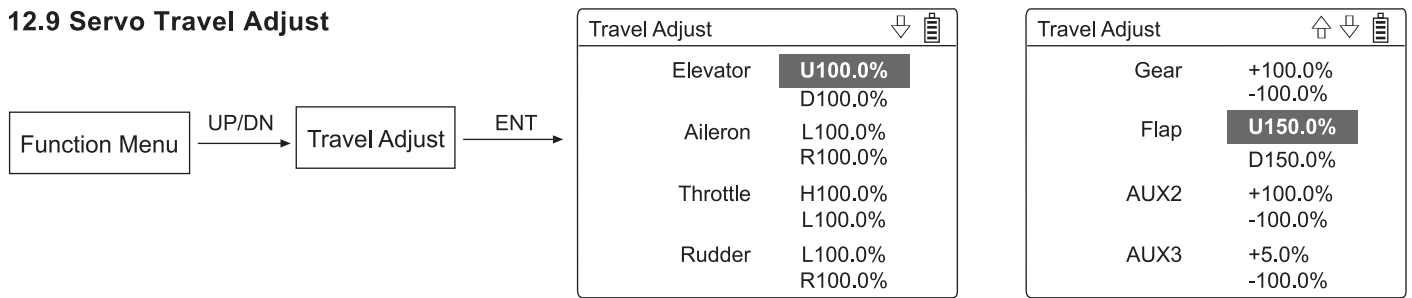

Press UP or DN to select Flap channel, Press R or L to set as **U150.0% and D150.0%**.

Press UP or DN to select AUX3 channel, press R or L to set **+5.0%(5 means Roundly cruise flying radius is 5 metre) and -100.0%**, then press EXT to return Function Menu.

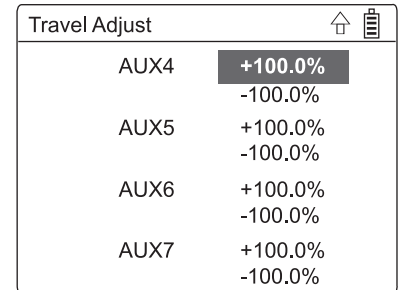

## 12.10 Senser View

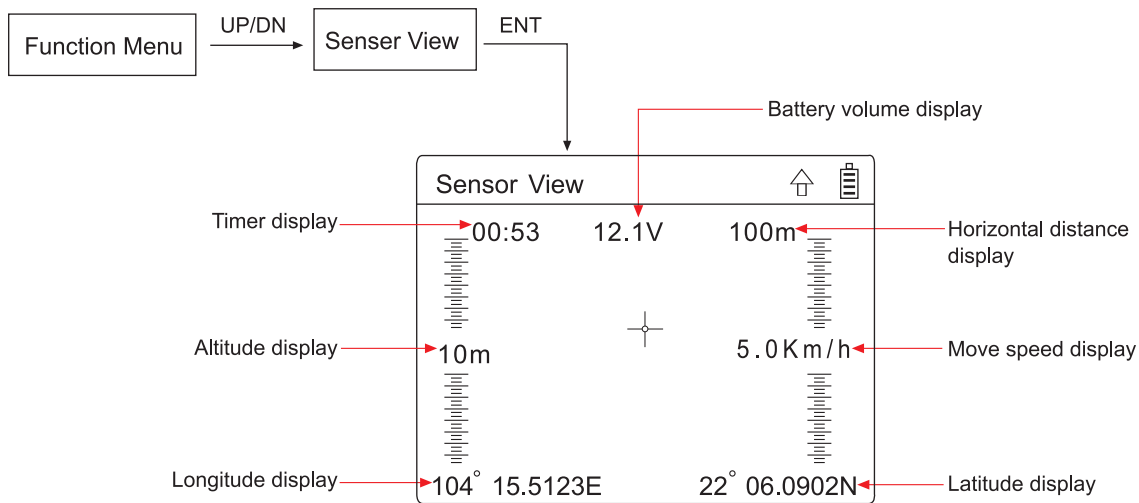

Press R or L to select viewport display. When set the image as background, Information will be displayed on the image.

## 12.11 Video Setting

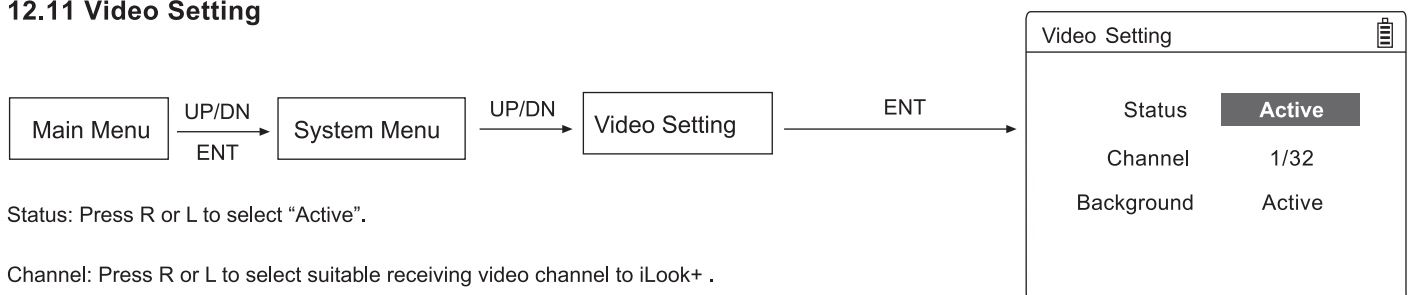

Status: Press R or L to select "Active".

Channel: Press R or L to select suitable receiving video channel to iLook+ .

Background: Press R or L to select Active, Real-time image could be set as background in Main Menu.

Press EXT to show full screen image in Main Menu.

## 12.12 Timer Setting

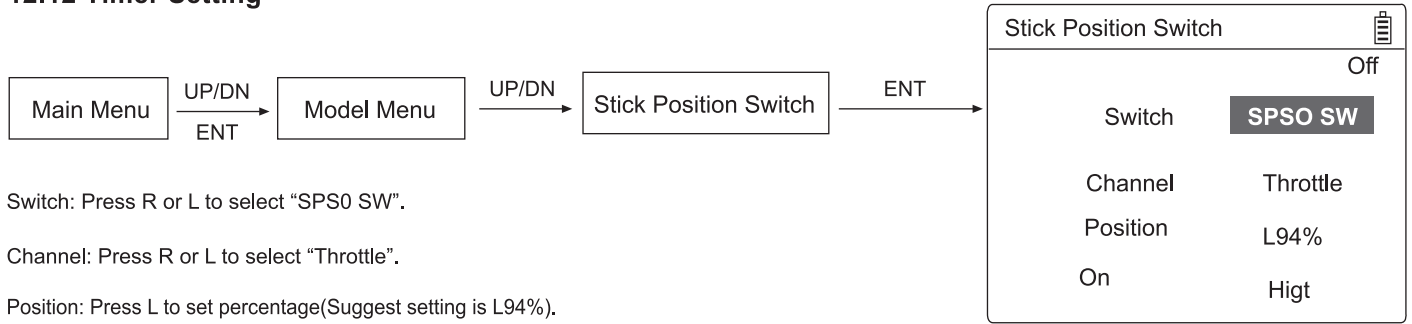

Switch: Press R or L to select "SPSO SW".

Channel: Press R or L to select "Throttle".

Position: Press L to set percentage(Suggest setting is L94%).

On setting: Press R or L to select "High" as rocker direction of on.

Move up and down of the throttle to check if the direction of the switch is set correctly. Then press EXT to return "Main Menu".

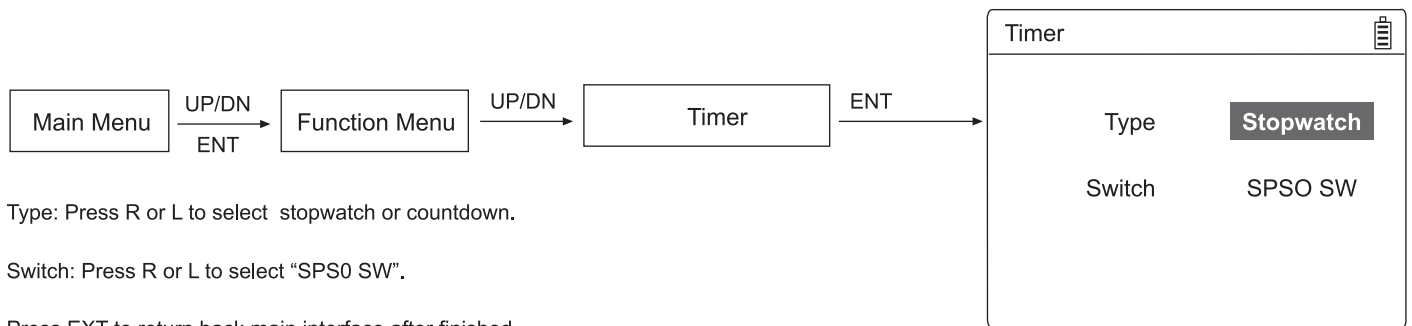

Type: Press R or L to select stopwatch or countdown.

Switch: Press R or L to select "SPSO SW".

Press EXT to return back main interface after finished.

**Usage:** Toggle the throttle up to L94% to start the time, toggle the throttle down to L94% to stop the time, press DN to reset.

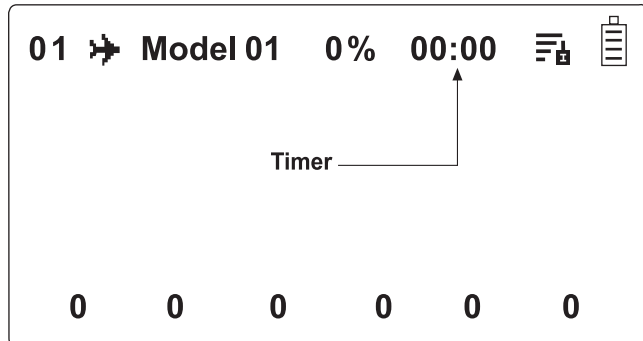

## 13.0 FCS-X4 Main controller guideline

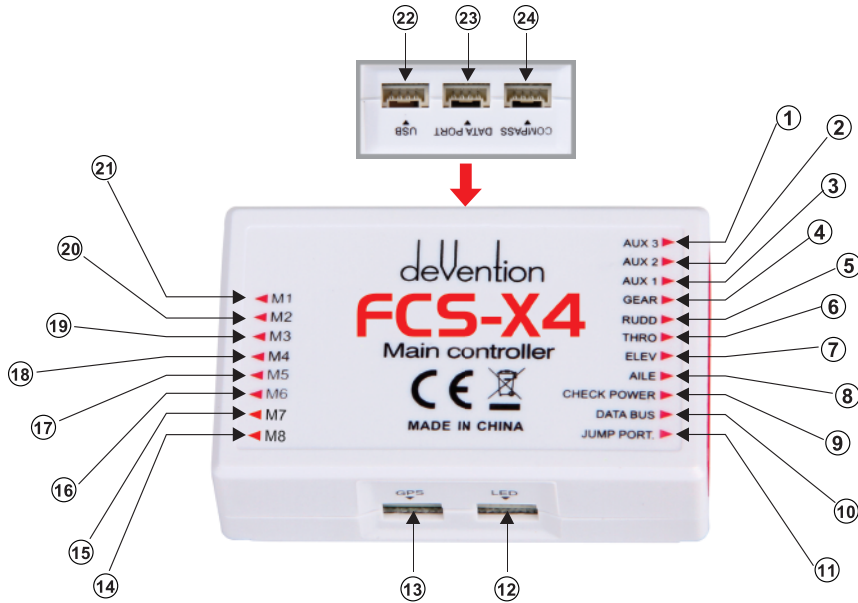

①	To roundly cruise flight mode	⑨	To check voltage(connect with power board)	⑰	Connect with fifth way brushless ESC
②	To hyper IOC	⑩	Used for data transmission-connect the PPM OUT port of BT-2401A/2402A	⑱	Connect with forth way brushless ESC
③	To one key to take off	⑪	Jumper port, when regular receiver is need, insert random equipped bind plug pls.	⑲	Connect with third way brushless ESC
④	Control Mode Switch	⑫	To link LED	⑳	Connect with second way brushless ESC
⑤	To control Rudder	⑬	To link GPS module(red white blue black four color cable)	㉑	Connect with first way brushless ESC
⑥	To control Throttle	⑭	Connect with eighth way brushless ESC	㉒	Upgrade channel
⑦	To control Elevator (forward & backward)	⑮	Connect with seventh way brushless ESC	㉓	Data communcation port
⑧	To control Aileron (leftward & rightward)	⑯	Connect with sixth way brushless ESC	㉔	To link Compass (red black double color cable)

## 14.0 DEVO RX707(CE)/RX709(FCC) Receiver guideling

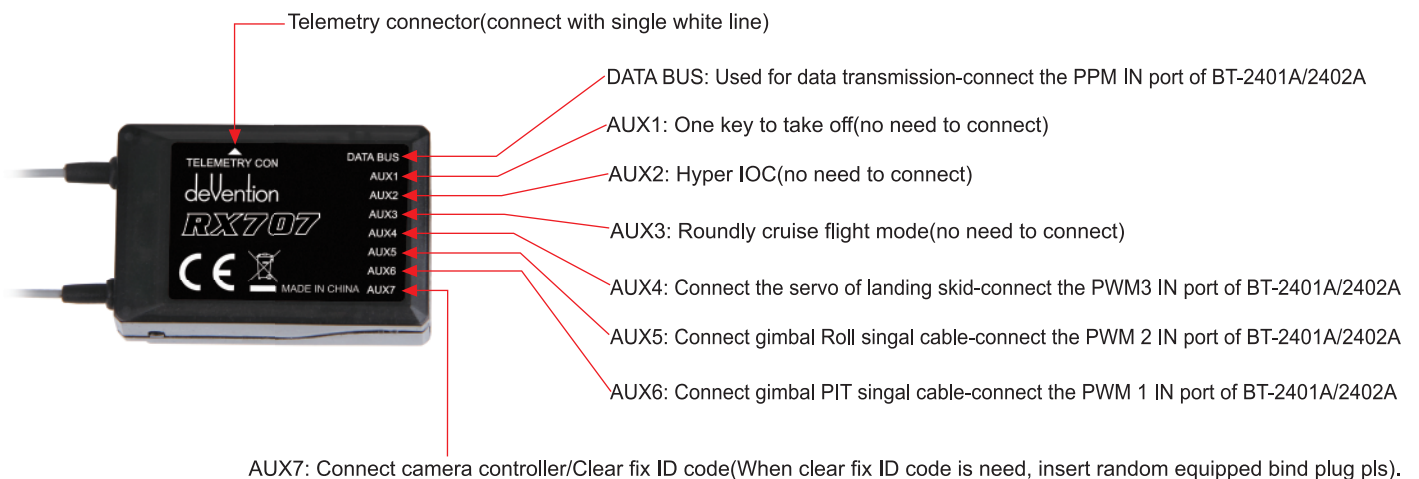

**Attention: DEVO RX707(CE) and DEVO RX709(FCC)have the same ports.**



## 15.0 Instruction for knobs of G-3D gimbal

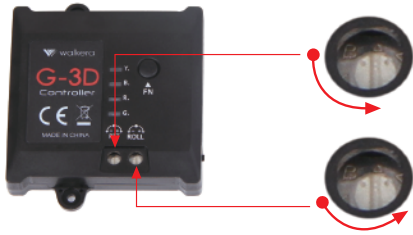

**PIT:** Set up gimbal tilt angle(control angle range  $-135^{\circ}\sim 90^{\circ}$ ), please refer to the mid-point as starting point, proper adjust the knob in counterclockwise direction.

**ROLL:** Set up gimbal rolling angle(control angle range  $45^{\circ}\sim 45^{\circ}$ ), please refer to the mid-point as starting point, proper adjust the knob in counterclockwise direction.

## 16.0 iLook+ Camera Setting

### 16.1 Pictures illustration

### 16.2 Specifications

#### (1) Video

- a. Video Resolution: 1920 x1080 Full HD
- b. FPS: 30
- c. Micro High Speed SD card: Max 64G
- d. Imaging Sensor: 3,000,000 Pixels
- e. Video Format: MOV
- f. Photo: 4032x3024 Pixels



#### (2) 5.8G wireless

- a. 5.8G wireless image transmission
- b. FCC Output Power $\leq 200\text{mW}$
- c. CE Output Power $\leq 25\text{mW}$
- d. CE Bind B section: 8 channels
- e. FCC Bind B section: 4 channels



### 16.3 iLook+(FCC/CE) camera transmitting channel selection

There are 8 different channels can be selected. You can choose the best frequency channel according to the image quality as bellow:

Channel	1	2	3	4	5	6	7	8
Frequency	5866MHz	5847MHz	5828MHz	5809MHz	5790MHz	5771MHz	5752MHz	5733MHz
code position (off/on)	 ON	 ON	 ON	 ON	 ON	 ON	 ON	 ON

**Note:** Only transmitting channel 2, 4, 6, 8 are available for the iLook/iLook+(FCC).

## 16.4 Video and Photo user guide

### Warm tips:

- (1) Micro SD card must be inserted to the iLook+ camera before connecting the power, and took off after disconnecting the power.  
(Recommend to use high speed SD card)
- (2) Insert MICRO SD card, the camera is powered on, the red indicator light indicates the camera is initialized, the red light goes out indicates the camera enters standby mode initialization is complete.
- (3) Insert MICRO SD card, the camera is powered on, if the red indicator light blinks rapidly means formatting it is necessary.pls stir video/ photo switch to  position press shutter last for 5 sec.format after the completion of the proposed re-energized camera.

### (1) Video instruction

#### (1.1) Radio Operation

Switch	Transmitter setting	Instructions
AILE D/R	<p style="text-align: center;"> <b>Model Menu</b>            ↓  <b>Device Output</b>            ↓  <b>AUX7</b>            ↓  <b>AILE D/R</b>            ↓  <b>Active</b> </p>	<p>(1) It's a must to turn the switch of iLook+ to " " position.</p> <p>(2) Start video: turn the AILE D/R switch from "0" position to "1" position, wait for 1-2 seconds, then return to "0" position, the camera will start to video (the red indicator keeps flash with an interval of 0.5 second). The red indication of video status can be seen on the transmitter.</p> <p>Stop video: turn the AILE D/R switch from "0" position to "1" position, wait for 1-2 seconds, then return to "0" position, the camera will stop video (the red indicator lights out). And the red indication of video status can not be seen on the transmitter.</p> <p>(3) Make sure that the video recorded will not be saved in the SD card if you haven't finished the "stop video" operation.</p>

#### (1.2) Manual Operation

Turn the Video/Photo Switch to  first please, press the shutter button once, iLook+ camera starts to Video(the Red indicator flash for 0.5sec interval); Press the shutter button again, iLook+ camera stops video(The Red indicator light out).

#### (2) Photo instruction

Please Turn the video/photo switch to , Press the shutter button once, iLook camera Will take a photo (The Red indicator blinks once then light out), press the shutter button again, it will take another photo.

## 17.0 Connect charger instruction

Slide the power switch to "ON" position when charging, press the power button for 3-5 seconds till the power indicator keeps on.

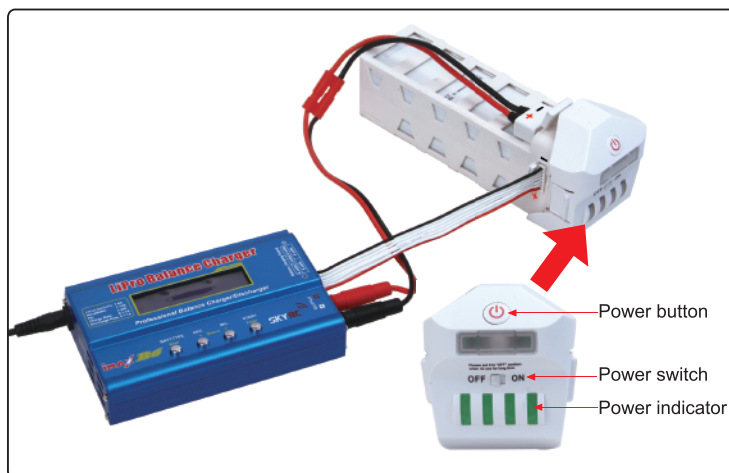

For details, please refer to iMAX B6 user manual.

## **FCC Information**

This device complies with part 15 of the FCC results. Operations is subject to the following two conditions:

- (1) This Device may not cause harmful interface, and
- (2) This device must accept any interference received, including interference that may cause undesired operation.

Note: This equipment has been tested and found to comply with the limits for CLASS B digital device, pursuant to part 15 of FCC Rules. These Limits are designed to provide reasonable protection against harmful interference when the equipment is operated in a commercial environment. This equipment generates, users can radiate radio frequency energy and, if not installed and used in accordance with the instructions, may cause harmful interference to radio communications. However, there is no guarantee that interference will not occur in a particular installation. If this equipment dose cause harmful interference to radio or television reception, which can be determined by turning the equipment off and on, the user is encouraged to try contact the interference by one or more of the following measures:

- 1.1 Reorient or relocate the receiving antenna.
- 1.2 Increase the separation between the equipment and receiver.
- 1.3 Connect the equipment into an outlet on a circuit different from that two which receiver is connected.
- 1.4 Consult the dealer or experienced radio/TV technician for help.

## **WARNING**

Changes or modifications not expressly approved by the manufacturer could void the user's authority to operate the equipment.

## **RF exposure statement**

This module meets the requirements for a mobile device that may be used at separation distances of more than 20cm from the human body. It may be used in hand-held controllers that provide a separation distance of at least 5cm between the antenna and the body (excluding hands wrists). The instructions to the user for the host device must include information requiring the product be used in a manner to ensure the appropriate separation (20cm or 5cm) between antenna and body and requiring that the transmitter not be collocated with another transmitter device.

Tel.: (8620) 8491 5115 8491 5116

Fax.: (8620) 8491 5117

Email: [heli@walkera.com](mailto:heli@walkera.com)  
[info@walkera.com](mailto:info@walkera.com)

Add.: Taishi Industrial Park, Dongchong Town  
nansha District, 511475 Guangzhou

# deVention

Specifications, contents of parts and availability  
are subject to change, Walkera is not responsible  
for inadvertent errors  
in this publication.



Web: [www.walkera.com](http://www.walkera.com)