



**FCC CFR47 PART 15 SUBPART B
FCC CFR47 PART 15 SUBPART C**

CERTIFICATION TEST REPORT

FOR

BASE STATION RECEIVER

MODEL NUMBER: SS10-R

FCC ID: RQT-SS10RA

REPORT NUMBER: 09U12762-2

ISSUE DATE: AUGUST 21, 2009

Prepared for
DIGITAL SUN, INC.
5655 SILVER CREEK VALLEY ROAD, SUIT 434
SAN JOSE, CA 95138, U.S.A.

Prepared by
COMPLIANCE CERTIFICATION SERVICES
47173 BENICIA STREET
FREMONT, CA 94538, U.S.A.
TEL: (510) 771-1000
FAX: (510) 661-0888



NVLAP LAB CODE 200065-0

Revision History

<u>Rev.</u>	<u>Issue Date</u>	<u>Revisions</u>	<u>Revised By</u>
--	08/21/09	Initial Issue	F. Ibrahim

TABLE OF CONTENTS

1. ATTESTATION OF TEST RESULTS	4
2. TEST METHODOLOGY	5
3. FACILITIES AND ACCREDITATION	5
4. CALIBRATION AND UNCERTAINTY	5
4.1. <i>MEASURING INSTRUMENT CALIBRATION</i>	5
4.2. <i>SAMPLE CALCULATION</i>	5
4.3. <i>MEASUREMENT UNCERTAINTY</i>	5
5. EQUIPMENT UNDER TEST	6
5.1. <i>DESCRIPTION OF EUT</i>	6
5.2. <i>MAXIMUM OUTPUT POWER</i>	6
5.3. <i>DESCRIPTION OF AVAILABLE ANTENNAS</i>	6
5.4. <i>SOFTWARE AND FIRMWARE</i>	6
5.5. <i>WORST-CASE CONFIGURATION AND MODE</i>	7
5.6. <i>DESCRIPTION OF TEST SETUP</i>	8
6. TEST AND MEASUREMENT EQUIPMENT	12
7. ANTENNA PORT TEST RESULTS	13
7.1. <i>802.15.4 ZIGBEE MODE IN THE 2.4 GHz BAND</i>	13
7.1.1. <i>6 dB BANDWIDTH</i>	13
7.1.2. <i>OUTPUT POWER</i>	17
7.1.3. <i>AVERAGE POWER</i>	21
7.1.4. <i>POWER SPECTRAL DENSITY</i>	22
7.1.5. <i>CONDUCTED SPURIOUS EMISSIONS</i>	26
7.2. <i>TRANSMITTER ABOVE 1 GHz</i>	33
7.3. <i>WORST-CASE BELOW 1 GHz</i>	42
7.4. <i>DIGITAL DEVICE BELOW 1 GHz</i>	45
8. AC POWER LINE CONDUCTED EMISSIONS	48
9. MAXIMUM PERMISSIBLE EXPOSURE	52
10. SETUP PHOTOS	55

1. ATTESTATION OF TEST RESULTS

COMPANY NAME: DIGITAL SUN, INC.
5655 SILVER CREEK VALLEY ROAD, SUIT 434
SAN JOSE, CA 95138, U.S.A.

EUT DESCRIPTION: BASE STATION RECEIVER

MODEL: SS10-R

SERIAL NUMBER: 60128

DATE TESTED: AUGUST 11 TO 13, 2009

APPLICABLE STANDARDS	
STANDARD	TEST RESULTS
CFR 47 Part 15 Subpart C	Pass

Compliance Certification Services, Inc. (CCS) tested the above equipment in accordance with the requirements set forth in the above standards. All indications of Pass/Fail in this report are opinions expressed by CCS based on interpretations and/or observations of test results. Measurement Uncertainties were not taken into account and are published for informational purposes only. The test results show that the equipment tested is capable of demonstrating compliance with the requirements as documented in this report.

Note: The results documented in this report apply only to the tested sample, under the conditions and modes of operation as described herein. This document may not be altered or revised in any way unless done so by CCS and all revisions are duly noted in the revisions section. Any alteration of this document not carried out by CCS will constitute fraud and shall nullify the document. This report must not be used by the client to claim product certification, approval, or endorsement by NVLAP, NIST, any agency of the Federal Government, or any agency of any government.

Approved & Released For CCS By:



FRANK IBRAHIM
EMC SUPERVISOR
COMPLIANCE CERTIFICATION SERVICES

Tested By:

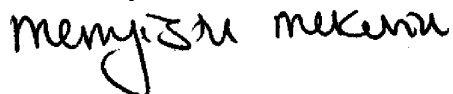

MENGISTU MEKURIA
EMC ENGINEER
COMPLIANCE CERTIFICATION SERVICES

2. TEST METHODOLOGY

The tests documented in this report were performed in accordance with ANSI C63.4-2003, FCC CFR 47 Part 2, and FCC CFR 47 Part 15.

3. FACILITIES AND ACCREDITATION

The test sites and measurement facilities used to collect data are located at 47173 Benicia Street, Fremont, California, USA.

CCS is accredited by NVLAP, Laboratory Code 200065-0. The full scope of accreditation can be viewed at <http://www.ccsemc.com>.

4. CALIBRATION AND UNCERTAINTY

4.1. MEASURING INSTRUMENT CALIBRATION

The measuring equipment utilized to perform the tests documented in this report has been calibrated in accordance with the manufacturer's recommendations, and is traceable to recognized national standards.

4.2. SAMPLE CALCULATION

Where relevant, the following sample calculation is provided:

$$\begin{aligned} \text{Field Strength (dBuV/m)} &= \text{Measured Voltage (dBuV)} + \text{Antenna Factor (dB/m)} + \\ &\text{Cable Loss (dB)} - \text{Preamp Gain (dB)} \\ 36.5 \text{ dBuV} + 18.7 \text{ dB/m} + 0.6 \text{ dB} - 26.9 \text{ dB} &= 28.9 \text{ dBuV/m} \end{aligned}$$

4.3. MEASUREMENT UNCERTAINTY

Where relevant, the following measurement uncertainty levels have been estimated for tests performed on the apparatus:

PARAMETER	UNCERTAINTY
Conducted Disturbance, 0.15 to 30 MHz	3.52 dB
Radiated Disturbance, 30 to 1000 MHz	4.94 dB

Uncertainty figures are valid to a confidence level of 95%.

5. EQUIPMENT UNDER TEST

5.1. DESCRIPTION OF EUT

The EUT is an 802.15.4 Zigbee half duplex transceiver.

The radio module is manufactured by Digital Sun, Inc.

5.2. MAXIMUM OUTPUT POWER

The transmitter has a maximum peak conducted output power as follows:

Frequency Range (MHz)	Mode	Output Power (dBm)	Output Power (mW)
2405 - 2475	802.15.4 Zigbee	20.31	107.40

5.3. DESCRIPTION OF AVAILABLE ANTENNAS

The radio utilizes a dipole antenna, with a maximum gain of 2 dBi.

5.4. SOFTWARE AND FIRMWARE

Probe:

- The firmware was DSProbeTest, rev. 0.2, build 52.
- The Probe has no driver software.
- The test utility was DS Development Tool 2, rev. 0.1 (no build number).

Receiver:

- The firmware was DSReceiver, rev. 0.14, build 2557.
- The Receiver driver is an off-the-shelf USB-to-serial chip from FTDI, with the driver built into newer versions of Windows. Version is FTDI-driver-R9052154.zip. This driver was used only during the digital & line portions of the testing; normal use of the system does not require a driver.
- The test utility was DS Development Tool 2, rev. 0.1 (no build number).

5.5. WORST-CASE CONFIGURATION AND MODE

For radiated emissions below 1 GHz, the EUT was set to transmit at the channel with highest output power.

Worst-case data rate was selected as 250 Kb/s per input from client.

For the digital portion radiated test both units are tested together. Battery powered sensor was in an active mode while the receiver actively transferring data to the support laptop that are connected with other peripherals (printer and mouse).

5.6. DESCRIPTION OF TEST SETUP

SUPPORT EQUIPMENT

PERIPHERAL SUPPORT EQUIPMENT LIST				
Description	Manufacturer	Model	Serial Number	FCC ID
24 V TRANSFORMER	RAIN BIRD	FAU265-0656	637473-01 Rev A	N/A

I/O CABLES

I/O CABLE LIST						
Cable No.	Port	# of Identical Ports	Connector Type	Cable Type	Cable Length	Remarks
1	AC	1	AC	UN-SHIELDED	2.0 m	N/A

TEST SETUP

The EUT is a stand-alone unit during the tests. A support laptop used only to change power and channels setting when necessary.

SETUP DIAGRAM FOR TESTS

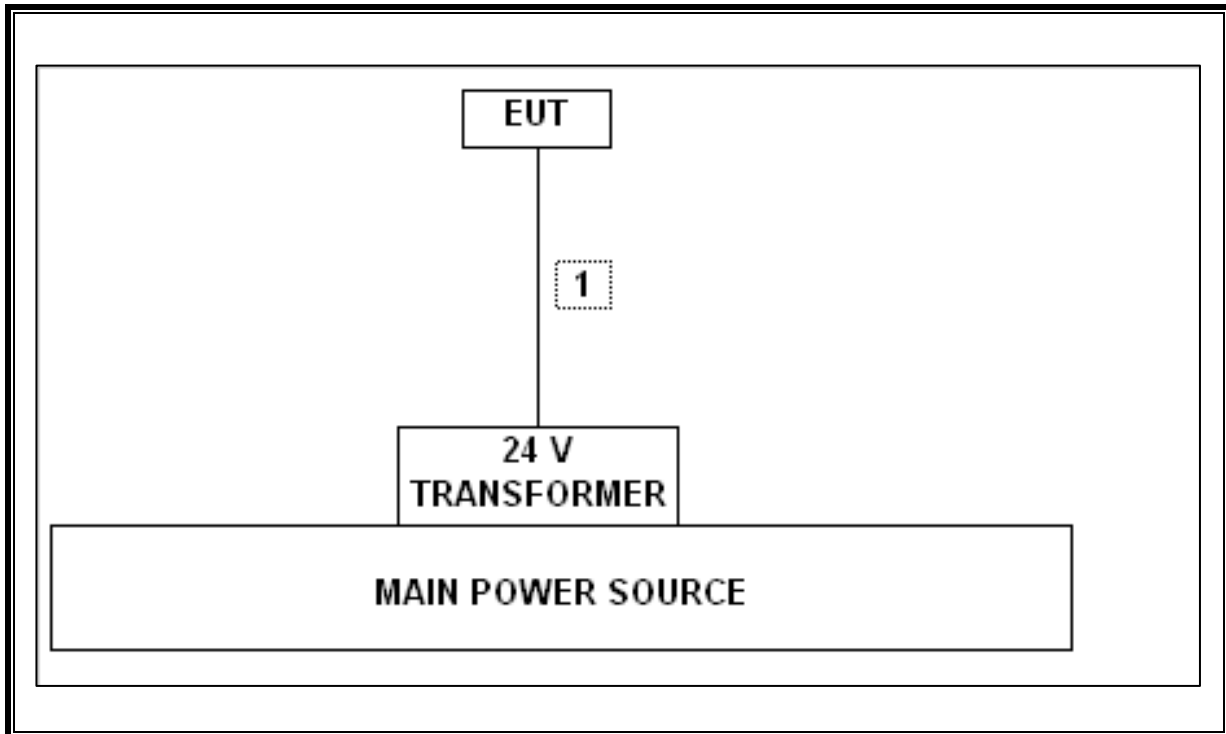

SETUP FOR DIGITAL DEVICE TESTS

SUPPORT EQUIPMENT

PERIPHERAL SUPPORT EQUIPMENT LIST				
Description	Manufacturer	Model	Serial Number	FCC ID
LAPTOP	DELL	D620	(01)07898349890528	DoC
AC/DC ADAPTER	DELL	PA-12	CN-ODF263-71615-66C-2F83	DoC
MOUSE	HP	MU48a	LZE01650095	N/A
PRINTER	Microline 186	D22300A	AC5C018494A0	DoC
Sensor	Digital Sun	SS10-S	50354	DoC

I/O CABLES

I/O CABLE LIST						
Cable No.	Port	# of Identical Ports	Connector Type	Cable Type	Cable Length	Remarks
1	AC	3	AC	UN-SHELDDED	2.0 m	N/A
2	DC	1	DC	UN-SHELDDED	2.0 m	Ferrite at one End
3	USB	1	MINI-USB	UN-SHELDDED	1.0 m	N/A
4	USB	1	USB	UN-SHELDDED	2.0 m	N/A

TEST SETUP

The EUT is connected to a host laptop computer via USB cable during the tests. Test software exercised the radio card.

SETUP DIAGRAM FOR DIGITAL DEVICE TESTS

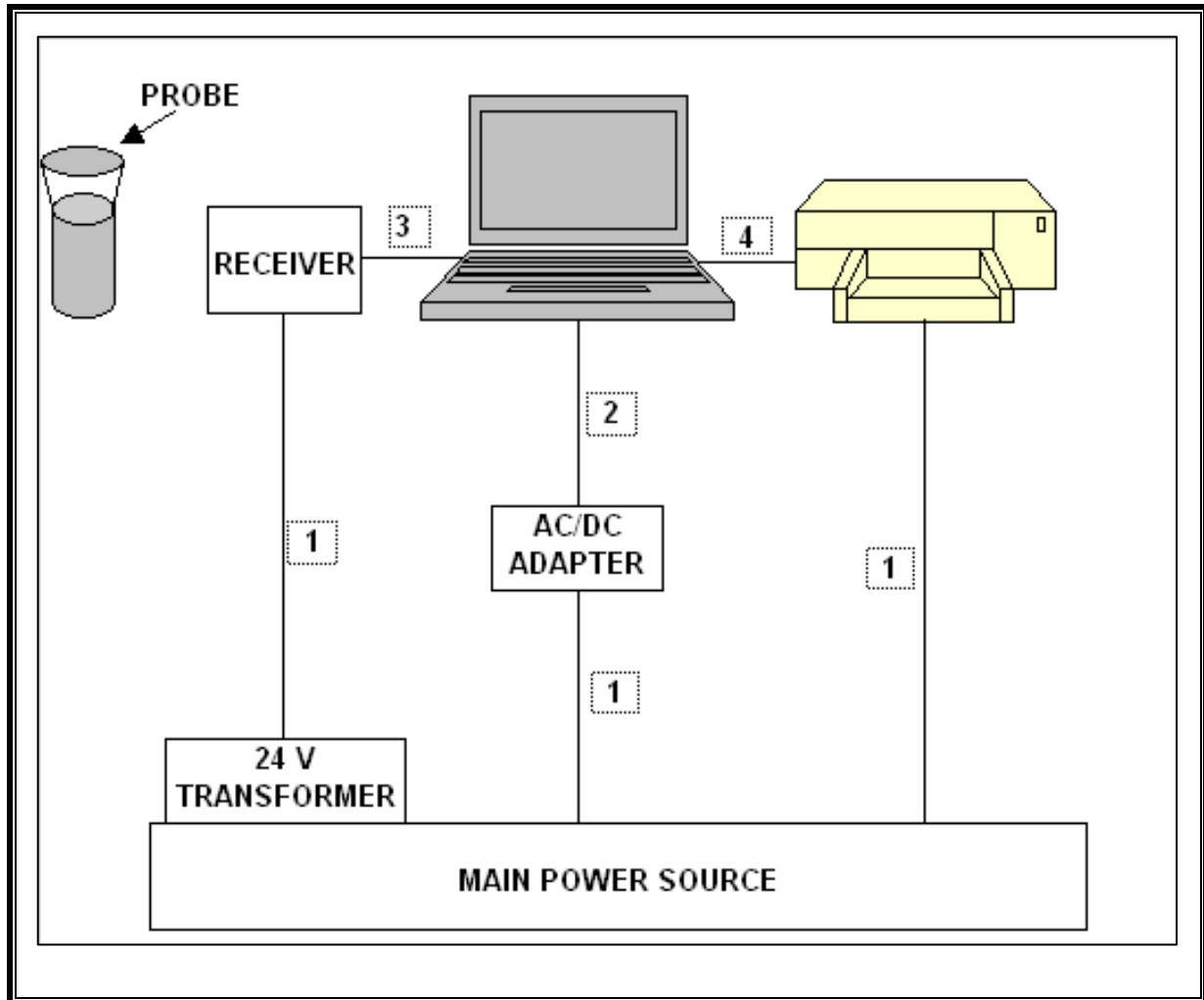

6. TEST AND MEASUREMENT EQUIPMENT

The following test and measurement equipment was utilized for the tests documented in this report:

TEST EQUIPMENT LIST					
Description	Manufacturer	Model	Asset	Cal Date	Cal Due
Peak Power Meter	Agilent / HP	E4416A	C00963	12/4/2007	12/4/2009
Peak / Average Power Sensor	Agilent / HP	E9327A	C00964	12/7/2007	12/7/2009
Spectrum Analyzer, 44 GHz	Agilent / HP	E4446A	C01159	11/7/2008	2/7/2010
Spectrum Analyzer, 44 GHz	Agilent / HP	E4446A	C00996	1/20/2009	4/20/2010
Antenna, Horn, 18 GHz	EMCO	3115	C00872	1/29/2009	1/29/2010
Antenna, Horn, 18 GHz	EMCO	3115	C00783	1/29/2009	1/29/2010
Antenna, Bilog, 2 GHz	Sunol Sciences	JB1	C01011	1/14/2009	1/14/2010
Antenna, Bilog, 2 GHz	Sunol Sciences	JB1	C01171	1/14/2009	1/14/2010
Preamplifier, 26.5 GHz	Agilent / HP	8449B	C01063	2/4/2009	2/4/2010
Preamplifier, 26.5 GHz	Agilent / HP	8449B	C00749	2/4/2009	2/4/2010
Preamplifier, 1300 MHz	Agilent / HP	8447D	C00778	12/16/2008	12/16/2009
Preamplifier, 1300 MHz	Agilent / HP	8447D	C00558	12/16/2008	12/16/2009
EMI Test Receiver, 30 MHz	R & S	ESHS 20	N02396	8/6/2009	5/6/2011
LISN, 30 MHz	FCC	LISN-50/250-25-2	N02625	10/29/2008	10/29/2009
LISN, 10 kHz ~ 30 MHz	Solar	8012-50-R-24-BNC	N02481	10/29/2008	10/29/2009

7. ANTENNA PORT TEST RESULTS

7.1. 802.15.4 ZIGBEE MODE IN THE 2.4 GHz BAND

7.1.1. 6 dB BANDWIDTH

LIMITS

FCC §15.247 (a) (2)

The minimum 6 dB bandwidth shall be at least 500 kHz.

TEST PROCEDURE

The transmitter output is connected to a spectrum analyzer. The RBW is set to 100 kHz and the VBW is set to 300 kHz. The sweep time is coupled.

RESULTS

Channel	Frequency (MHz)	6 dB Bandwidth (MHz)	Minimum Limit (MHz)
Low	2405	1.65	0.5
Middle	2445	1.65	0.5
High	2475	1.60	0.5

6 dB BANDWIDTH

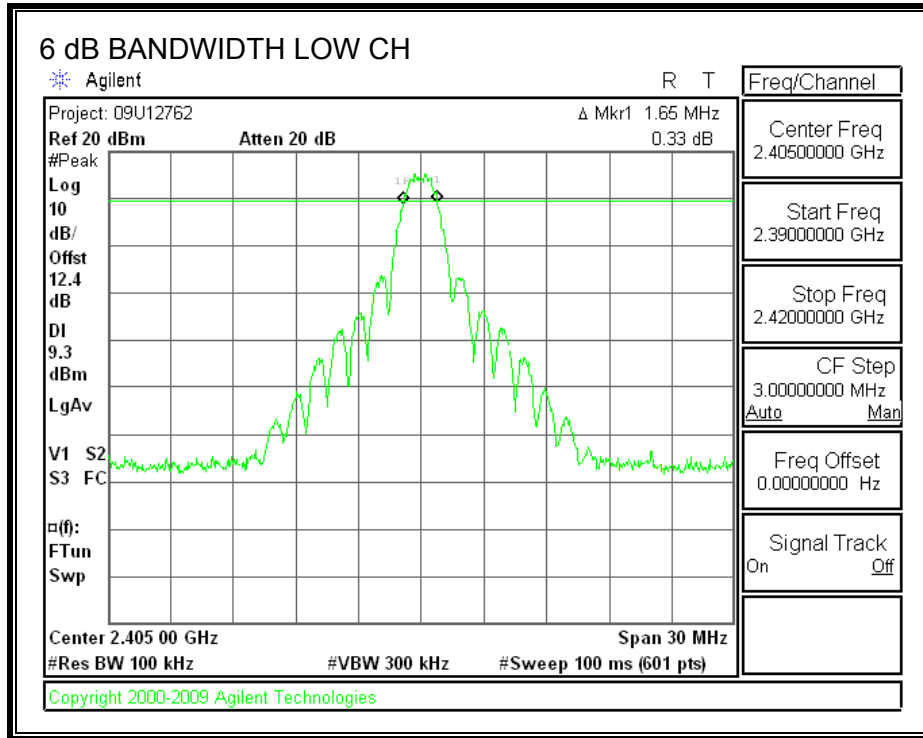

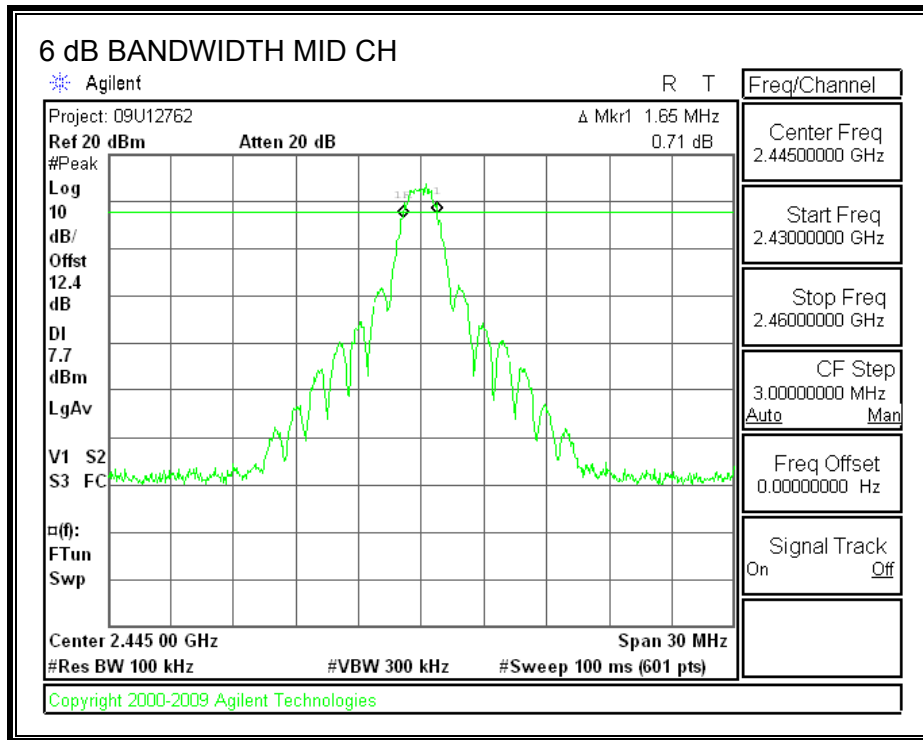

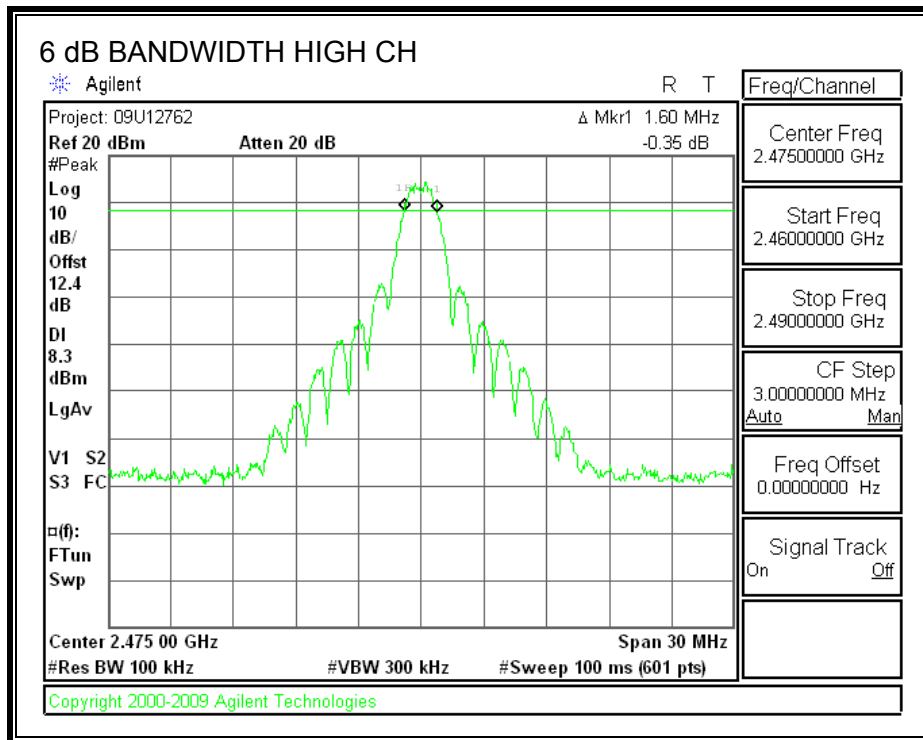

7.1.2. OUTPUT POWER

LIMITS

FCC §15.247 (b)

The maximum antenna gain is less than or equal to 6 dBi, therefore the limit is 30 dBm.

TEST PROCEDURE

Peak power is measured using the Channel bandwidth Alternative peak output power procedure specified in "TCB Training for Devices covered under Scopes A1 - A4" by Joe Dichoso, May 2003.

RESULTS

Channel	Frequency (MHz)	Spectrum Analyzer Reading (dBm)	Attenuator and Cable Offset (dB)	Output Power (dBm)	Limit (dBm)	Margin (dB)
Low	2405	7.91	12.4	20.31	30	-9.69
Middle	2445	6.21	12.4	18.61	30	-11.39
High	2475	6.60	12.4	19.00	30	-11.00

OUTPUT POWER

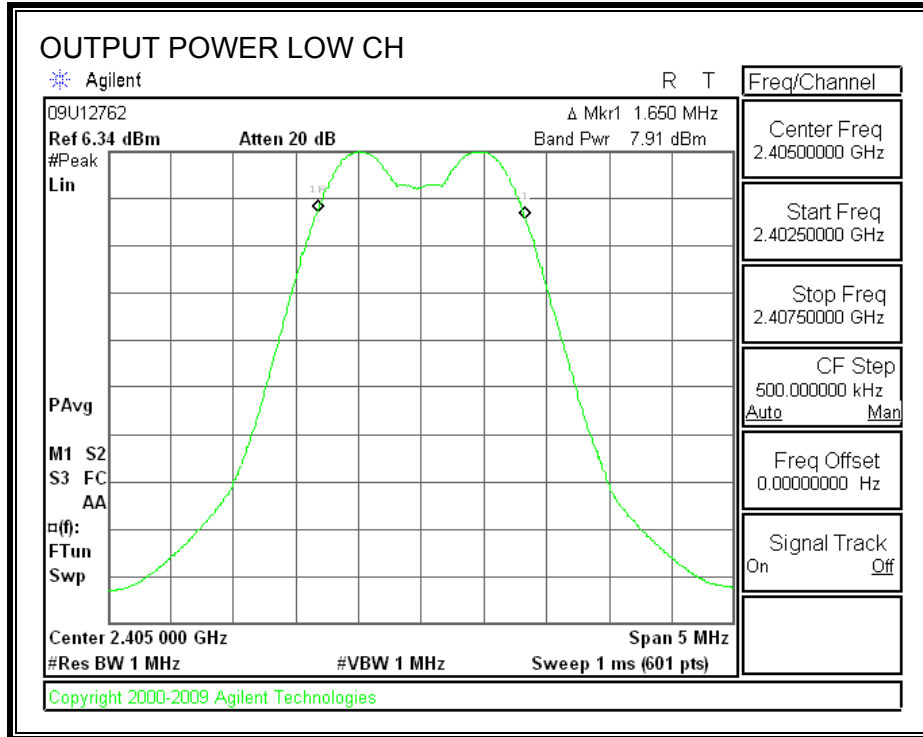

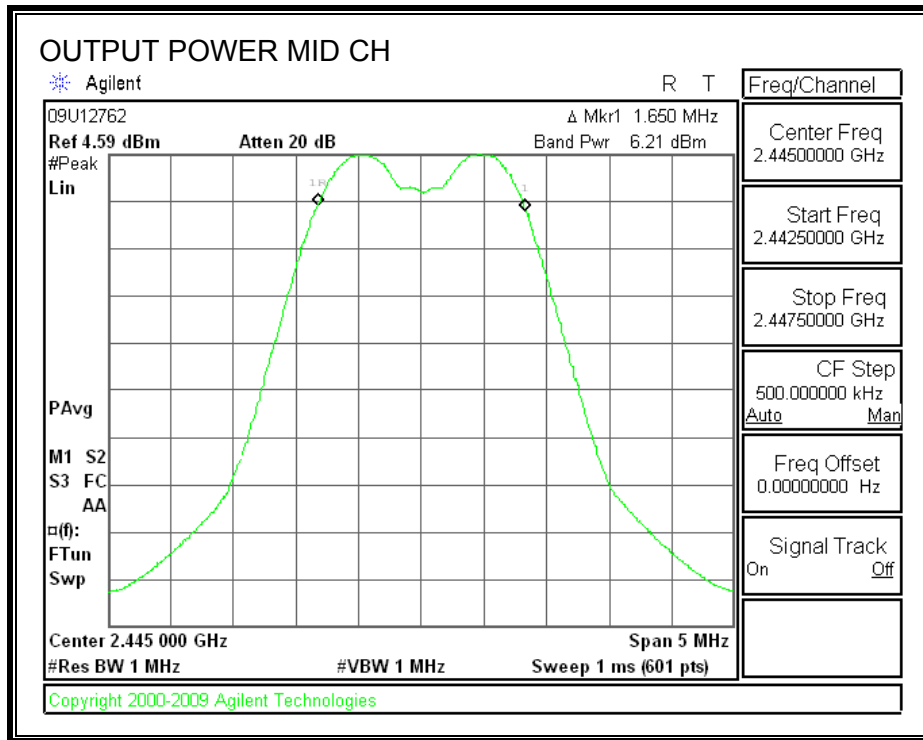

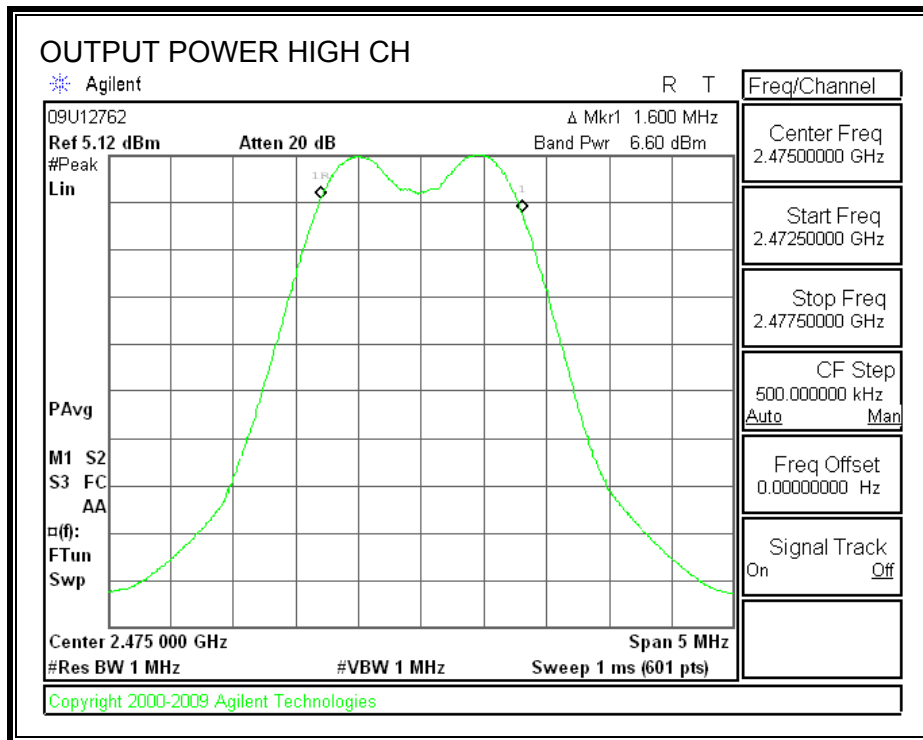

7.1.3. AVERAGE POWER

LIMITS

None; for reporting purposes only.

TEST PROCEDURE

The transmitter output is connected to a power meter.

RESULTS

The cable assembly insertion loss of 11 dB (including 10 dB pad and 1 dB cable) was entered as an offset in the power meter to allow for direct reading of power.

Channel	Frequency (MHz)	Power (dBm)
Low	2405	18.44
Middle	2445	16.41
High	2475	17.12

7.1.4. POWER SPECTRAL DENSITY

LIMITS

FCC §15.247 (e)

The power spectral density conducted from the transmitter to the antenna shall not be greater than 8 dBm in any 3 kHz band during any time interval of continuous transmission.

TEST PROCEDURE

Output power was measured based on the use of a peak measurement, therefore the power spectral density was measured using PSD Option 1 in accordance with FCC document "Measurement of Digital Transmission Systems Operating under Section 15.247", March 23, 2005.

RESULTS

Channel	Frequency (MHz)	PPSD (dBm)	Limit (dBm)	Margin (dB)
Low	2405	4.62	8	-3.38
Middle	2445	2.52	8	-5.48
High	2475	2.52	8	-5.48

POWER SPECTRAL DENSITY

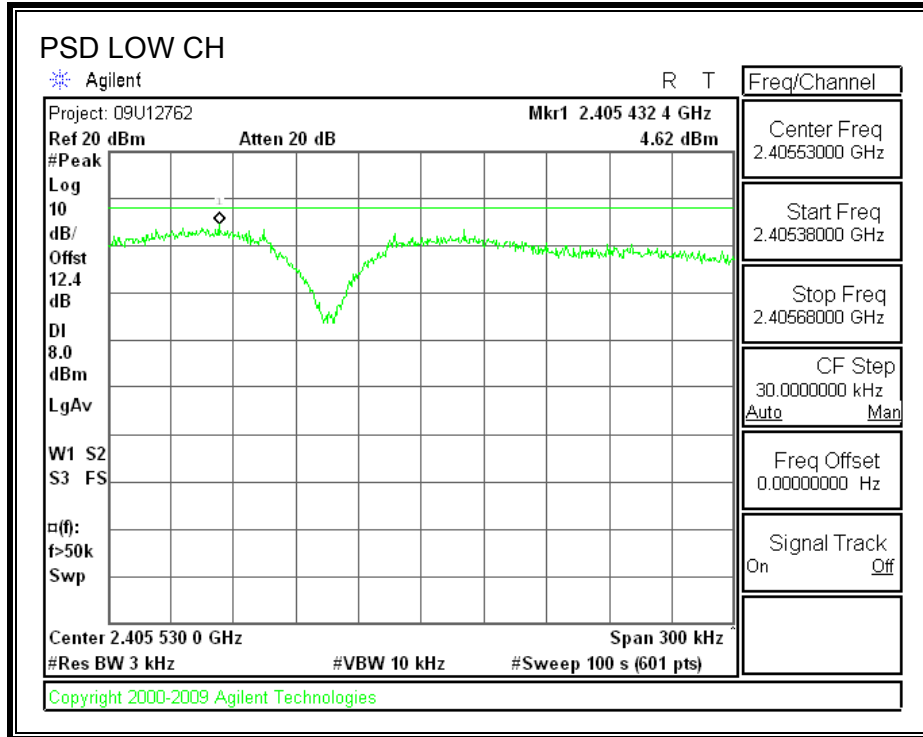

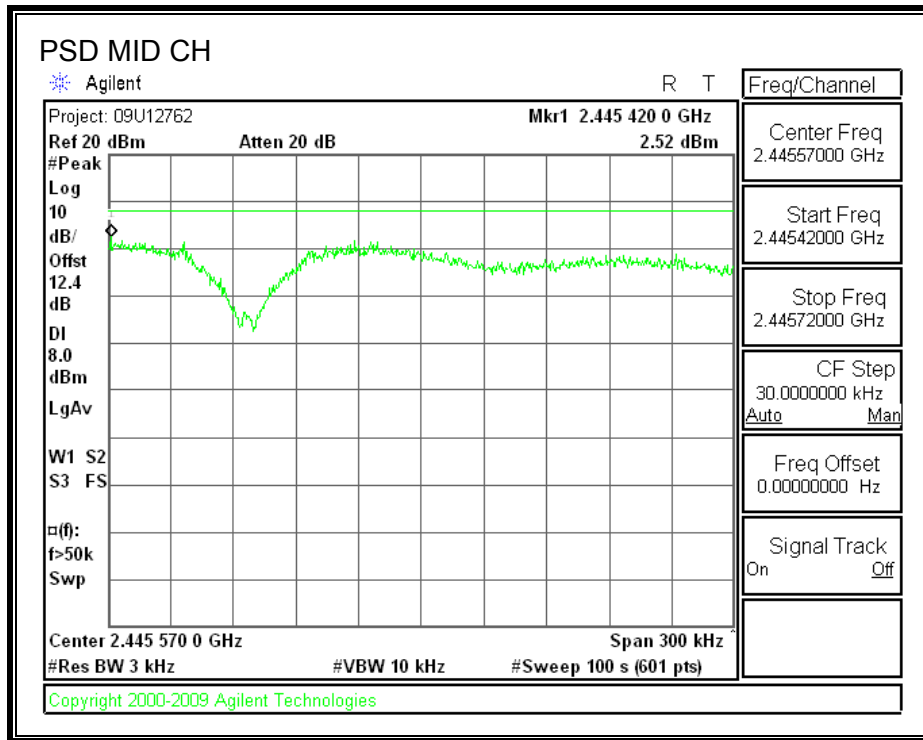

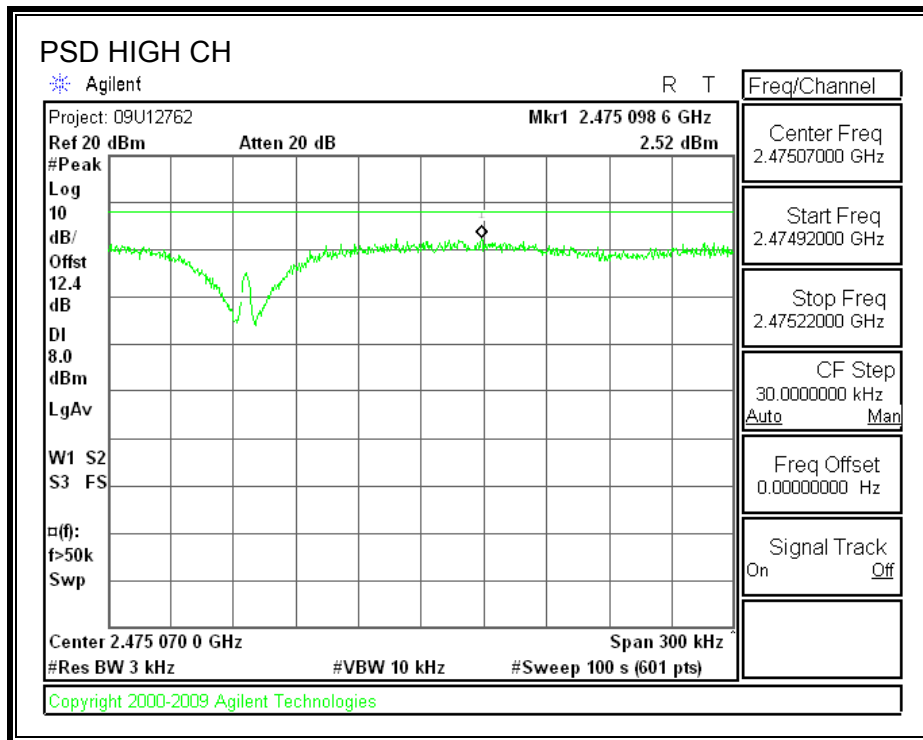

7.1.5. CONDUCTED SPURIOUS EMISSIONS

LIMITS

FCC §15.247 (d)

Output power was measured based on the use of a peak measurement, therefore the required attenuation is 20 dB.

TEST PROCEDURE

The transmitter output is connected to a spectrum analyzer. The resolution bandwidth is set to 100 kHz. The video bandwidth is set to 300 kHz.

The spectrum from 30 MHz to 26 GHz is investigated with the transmitter set to the lowest, middle, and highest channels.

RESULTS

SPURIOUS EMISSIONS, LOW CHANNEL

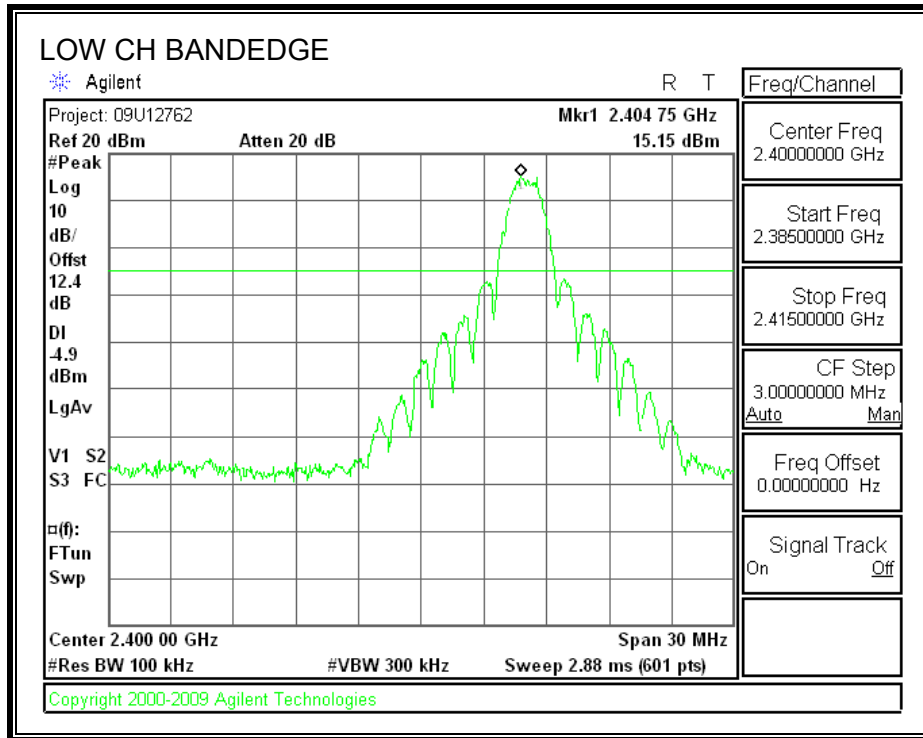

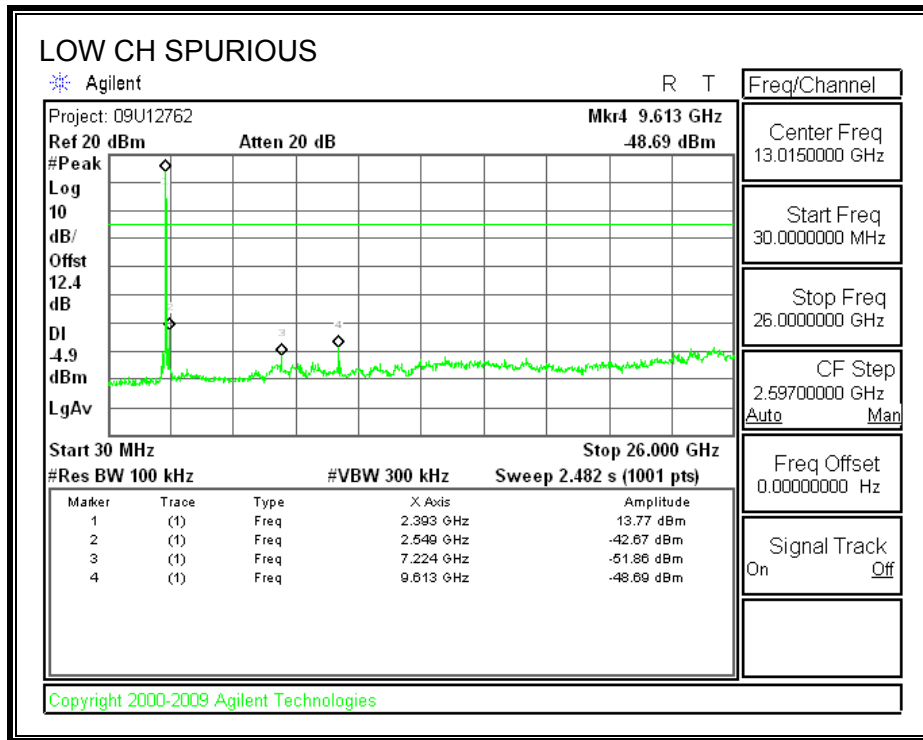

SPURIOUS EMISSIONS, MID CHANNEL

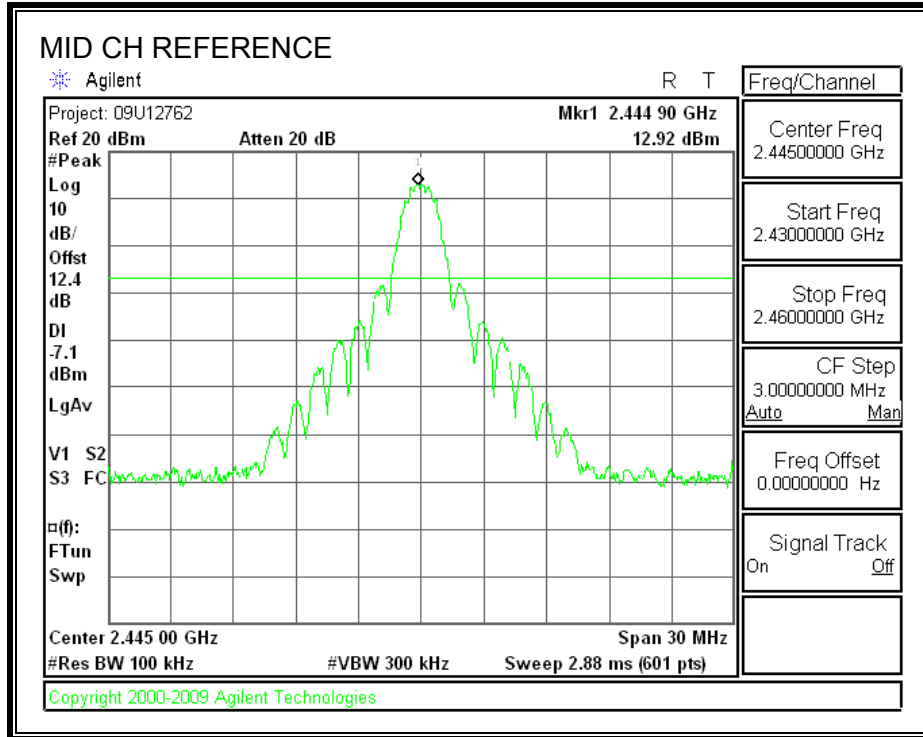

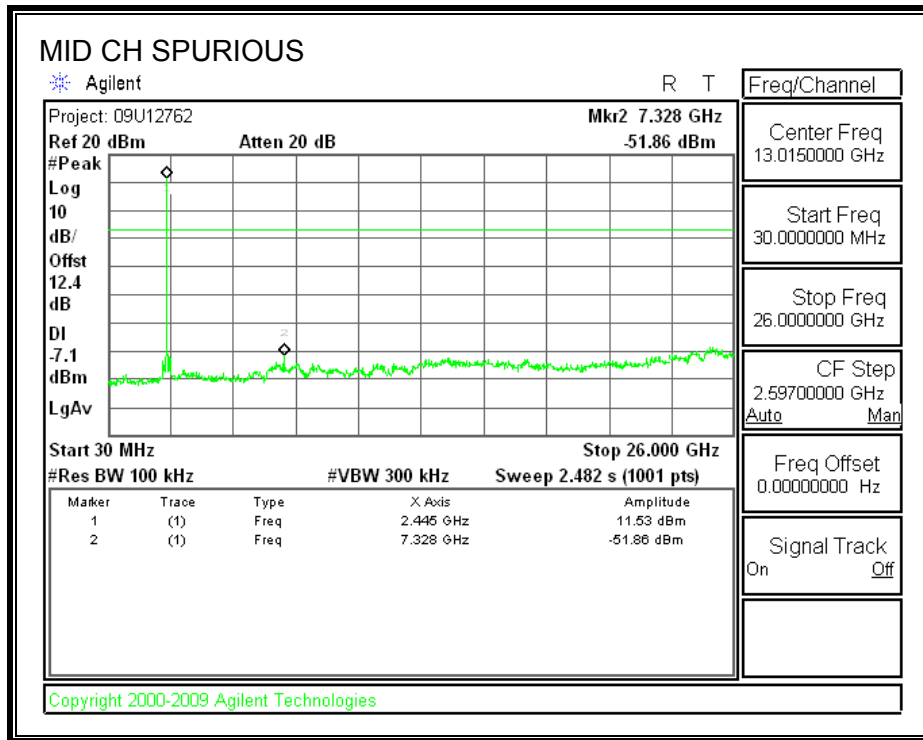

SPURIOUS EMISSIONS, HIGH CHANNEL

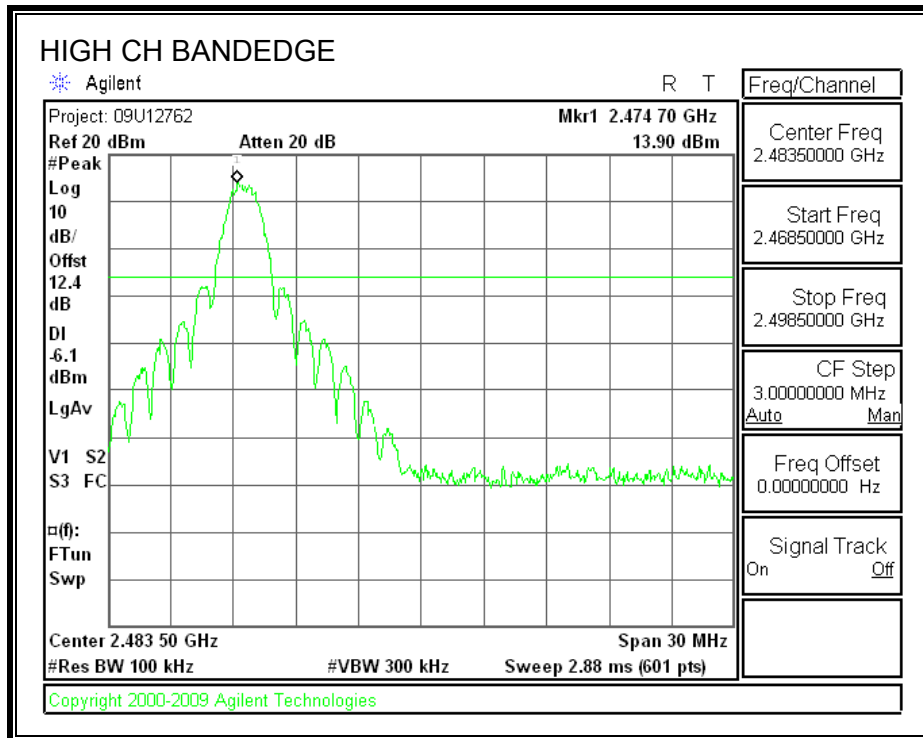

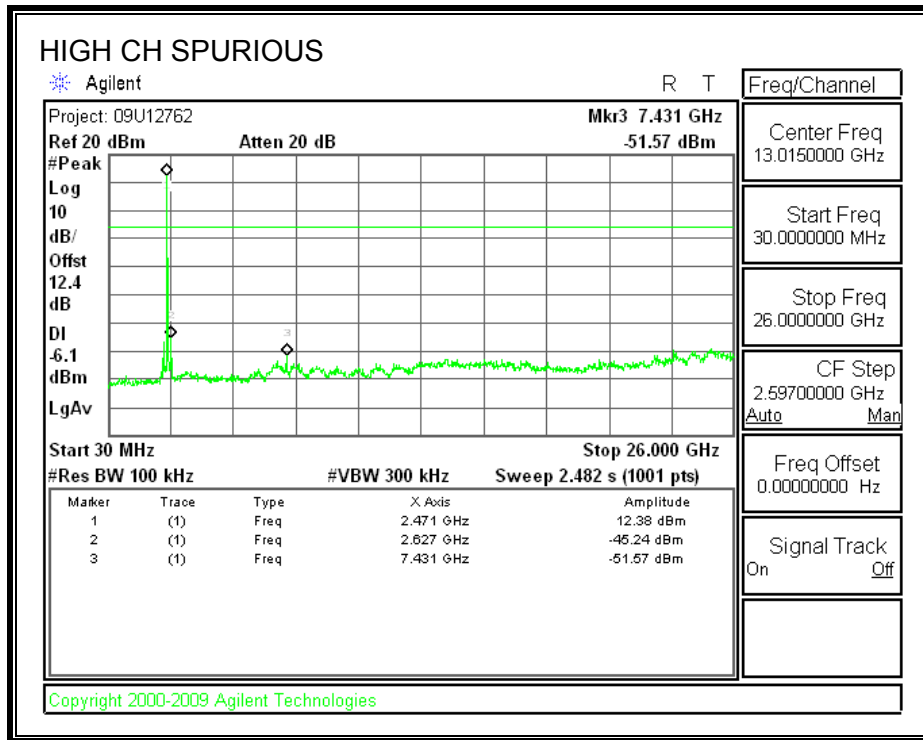

7.2. TRANSMITTER ABOVE 1 GHz

RESTRICTED BANDEDGE (LOW CHANNEL, HORIZONTAL)

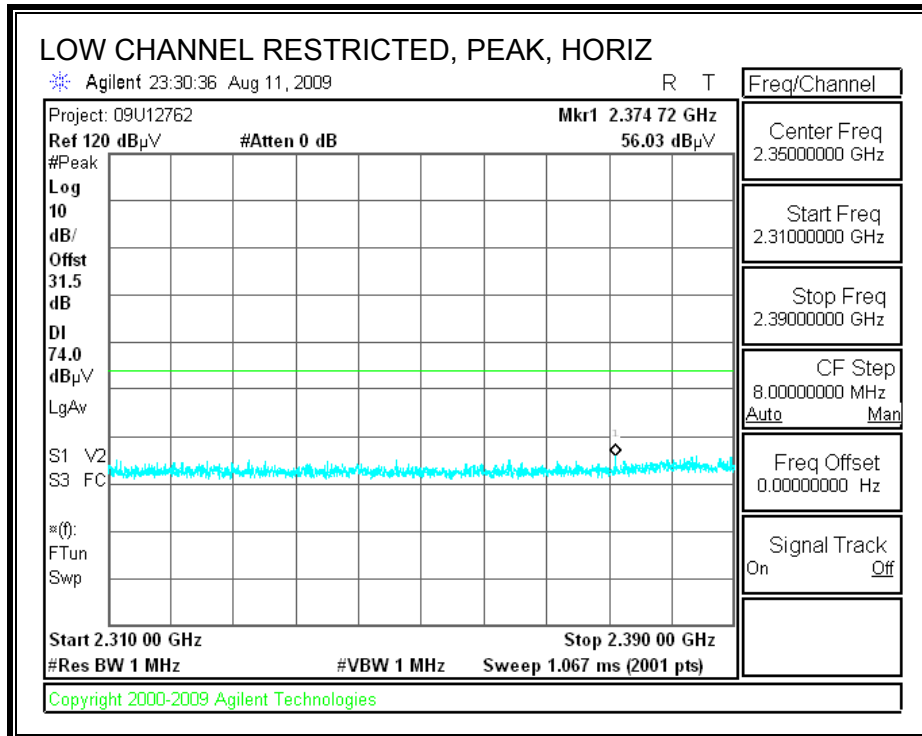

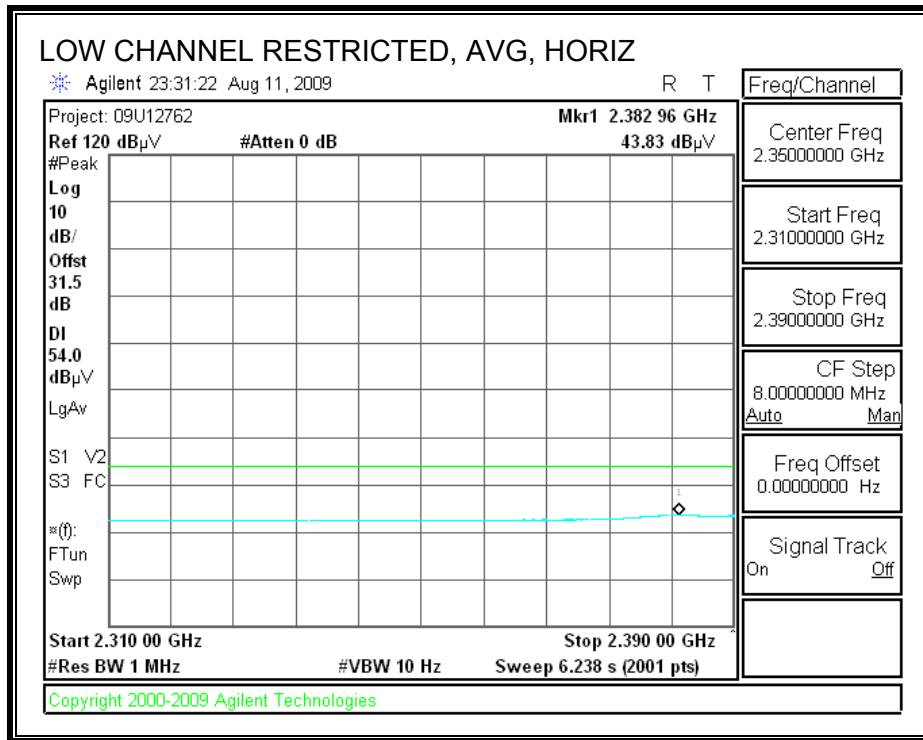

RESTRICTED BANDEDGE (LOW CHANNEL, VERTICAL)

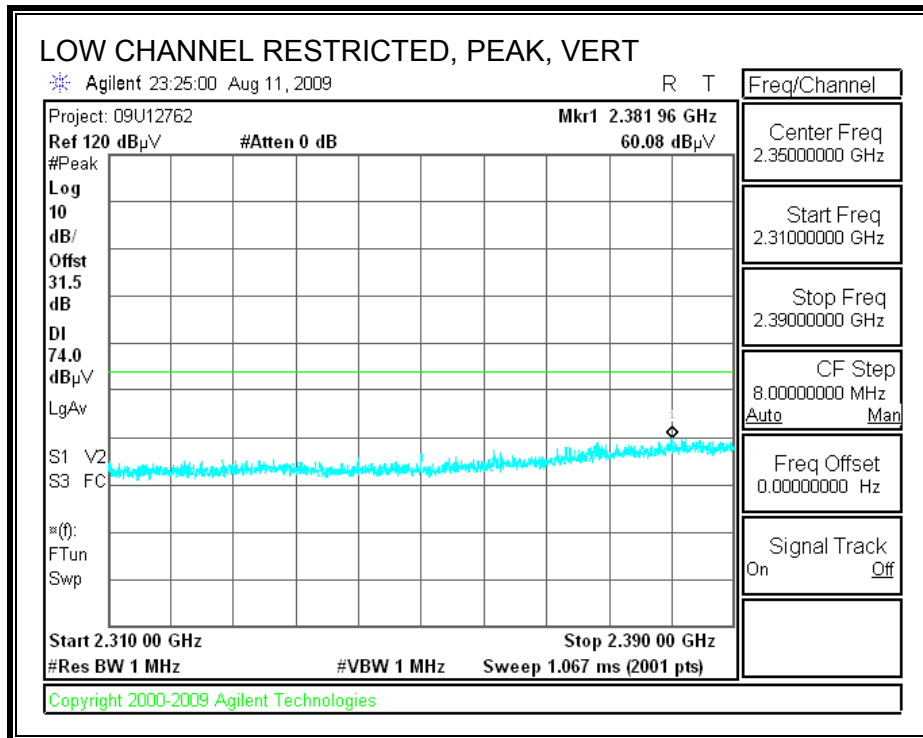

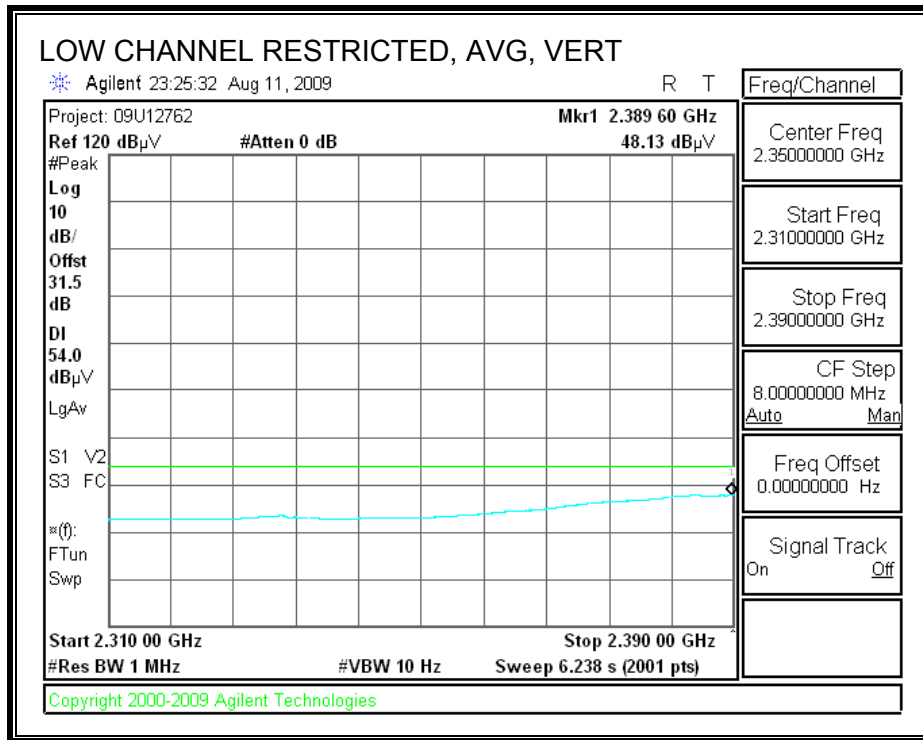

RESTRICTED BANDEDGE (HIGH CHANNEL, HORIZONTAL)

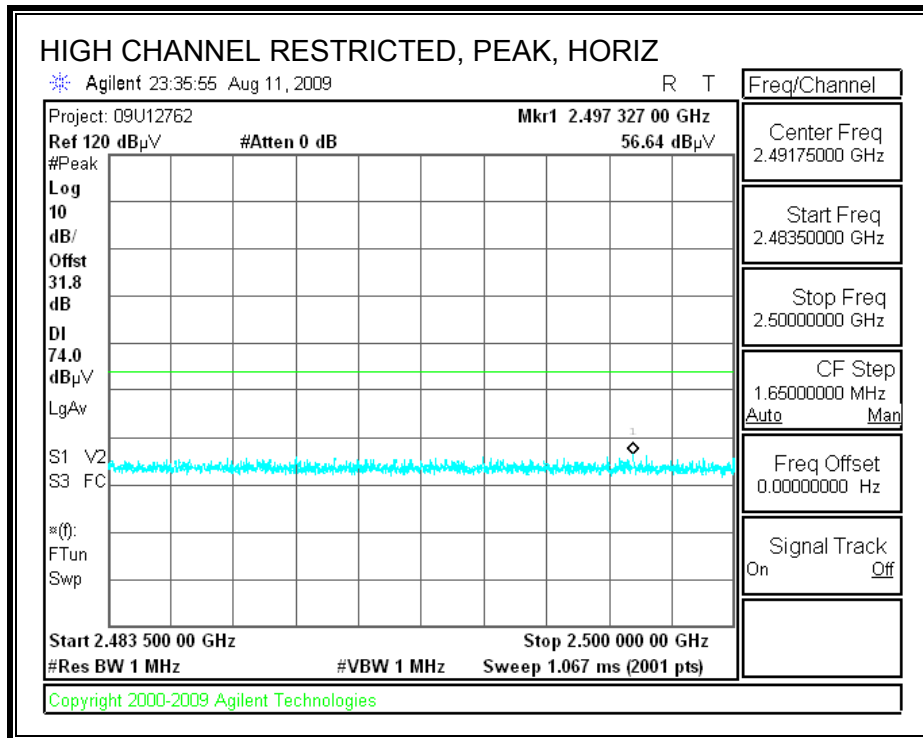

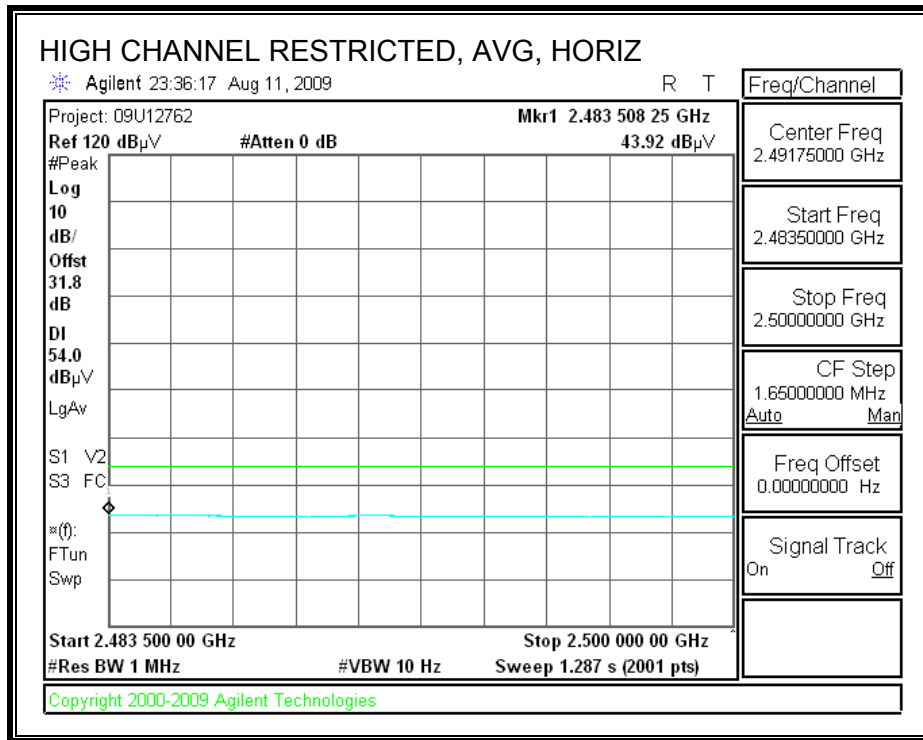

RESTRICTED BANDEDGE (HIGH CHANNEL, VERTICAL)

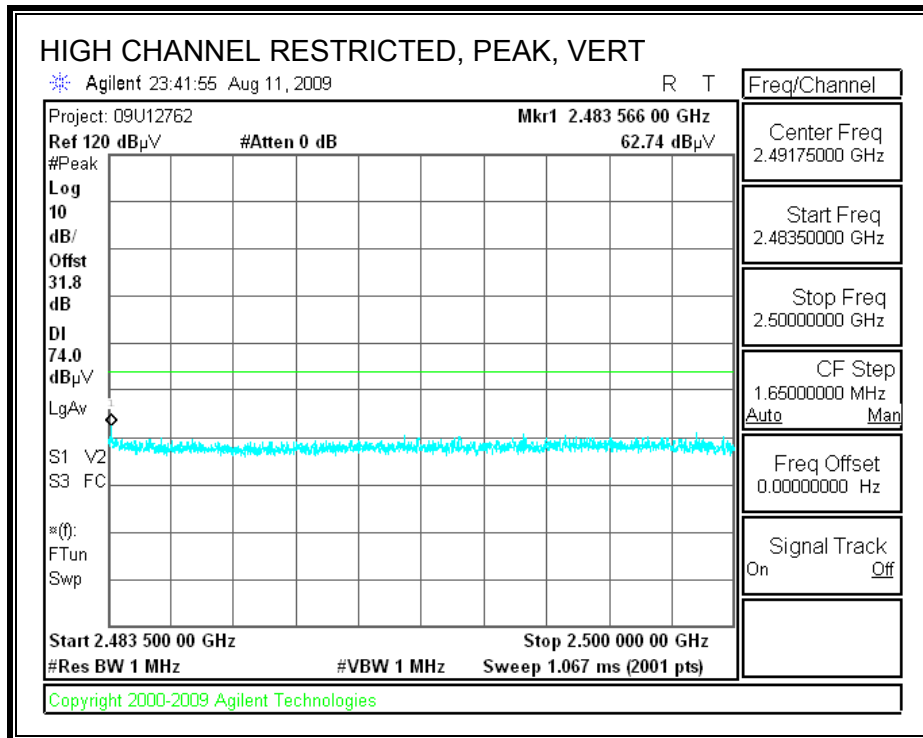

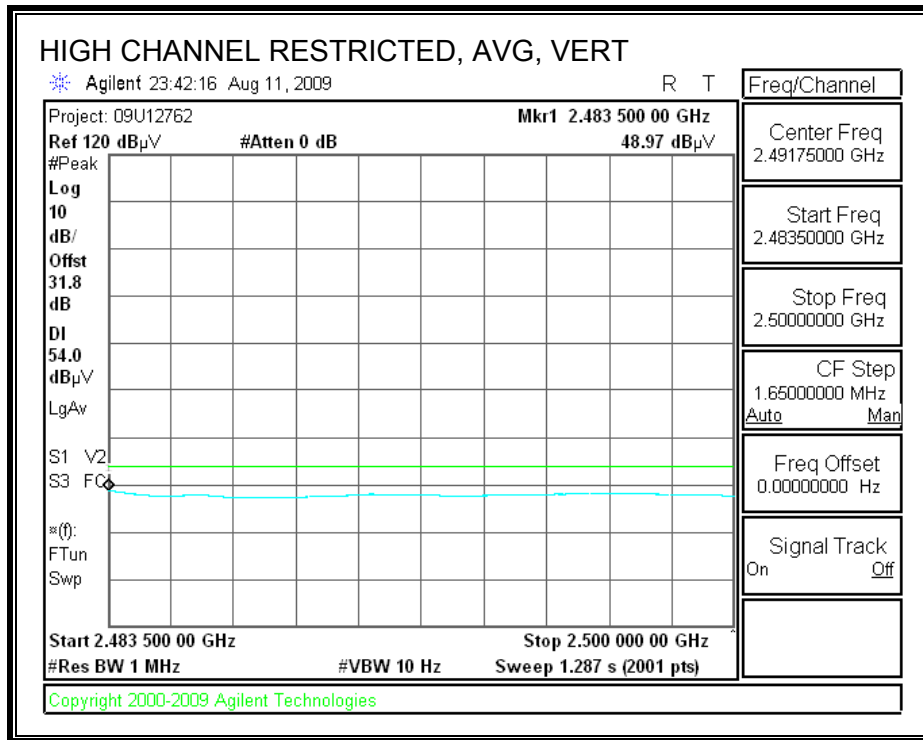

HARMONICS AND SPURIOUS EMISSIONS

High Frequency Measurement
 Compliance Certification Services, Fremont 5m Chamber

Company: DIGITAL SUN, INC.
 Project #: 09U12762
 Date: 8/11/2009
 Test Engineer: MENGISTU MEKURIA
 Configuration: EUT ALONE
 Mode: TXMODE

Test Equipment:

Horn 1-18GHz	Pre-amplifer 1-26GHz	Pre-amplifer 26-40GHz	Horn > 18GHz	Limit
T60; S/N: 2238 @3m	T34 HP 8449B			FCC 15.205

Hi Frequency Cables

3' cable 22807700	12' cable 22807600	20' cable 22807500	HPF	Reject Filter	Peak Measurements RBW=VBW=1MHz Average Measurements RBW=1MHz ; VBW=10Hz
3' cable 22807700	12' cable 22807600	20' cable 22807500		R_001	

Average=Peak-Duty Cycle (-20)

f	Dist	Read Pk	Read Avg.	AF	CL	Amp	D Corr	Fltr	Peak	Avg	Pk Lim	Avg Lim	Pk Mar	Avg Mar	Notes
GHz	(m)	dBuV	dBuV	dB/m	dB	dB	dB	dB	dBuV/m	dBuV/m	dBuV/m	dBuV/m	dB	dB	(V/H)
Low Ch, 2405MHz															
4.810	3.0	62.8	33.5	32.7	5.8	-34.8	0.0	0.0	66.4	37.1	74	54	-7.6	-16.9	V
12.025	3.0	49.4	19.0	38.5	9.7	-32.5	0.0	0.0	65.2	34.8	74	54	-8.8	-19.2	V
4.810	3.0	58.9	29.5	32.7	5.8	-34.8	0.0	0.0	62.5	33.2	74	54	-11.5	-20.8	H
12.025	3.0	46.3	15.9	38.5	9.7	-32.5	0.0	0.0	62.1	31.7	74	54	-11.9	-22.3	H
Mid Ch, 2445MHz															
4.890	3.0	66.8	37.4	32.7	5.8	-34.8	0.0	0.0	70.5	41.1	74	54	-3.5	-12.9	V
7.335	3.0	64.7	33.4	35.5	7.3	-34.1	0.0	0.0	73.4	42.1	74	54	-0.6	-11.9	V
12.225	3.0	50.4	19.7	38.5	9.8	-32.5	0.0	0.0	66.3	35.5	74	54	-7.7	-18.5	V
4.890	3.0	57.9	28.9	32.7	5.8	-34.8	0.0	0.0	61.6	32.7	74	54	-12.4	-21.3	H
7.335	3.0	64.8	33.5	35.5	7.3	-34.1	0.0	0.0	73.5	42.2	74	54	-0.5	-11.8	H
12.225	3.0	48.4	17.9	38.5	9.8	-32.5	0.0	0.0	64.2	33.7	74	54	-9.8	-20.3	H
High Ch, 2475MHz															
4.950	3.0	60.2	31.3	32.8	5.9	-34.8	0.0	0.0	64.0	35.2	74	54	-10.0	-18.8	V
7.425	3.0	64.8	33.1	35.6	7.3	-34.1	0.0	0.0	73.7	42.0	74	54	-0.3	-12.0	V
12.375	3.0	50.1	19.9	38.4	9.9	-32.5	0.0	0.0	65.9	35.8	74	54	-8.1	-18.2	V
4.950	3.0	55.1	25.0	32.8	5.9	-34.8	0.0	0.0	59.0	28.8	74	54	-15.0	-25.2	H
7.425	3.0	63.6	32.4	35.6	7.3	-34.1	0.0	0.0	72.5	41.2	74	54	-1.5	-12.8	H
12.375	3.0	46.7	16.4	38.4	9.9	-32.5	0.0	0.0	62.6	32.3	74	54	-11.4	-21.7	H

f	Measurement Frequency	Amp	Preamp Gain	Avg Lim	Average Field Strength Limit
Dist	Distance to Antenna	D Corr	Distance Correct to 3 meters	Pk Lim	Peak Field Strength Limit
Read	Analyzer Reading	Avg	Average Field Strength @ 3 m	Avg Mar	Margin vs. Average Limit
AF	Antenna Factor	Peak	Calculated Peak Field Strength	Pk Mar	Margin vs. Peak Limit
CL	Cable Loss	HPF	High Pass Filter		

7.3. WORST-CASE BELOW 1 GHz

SPURIOUS EMISSIONS 30 TO 1000 MHz (WORST-CASE CONFIGURATION)

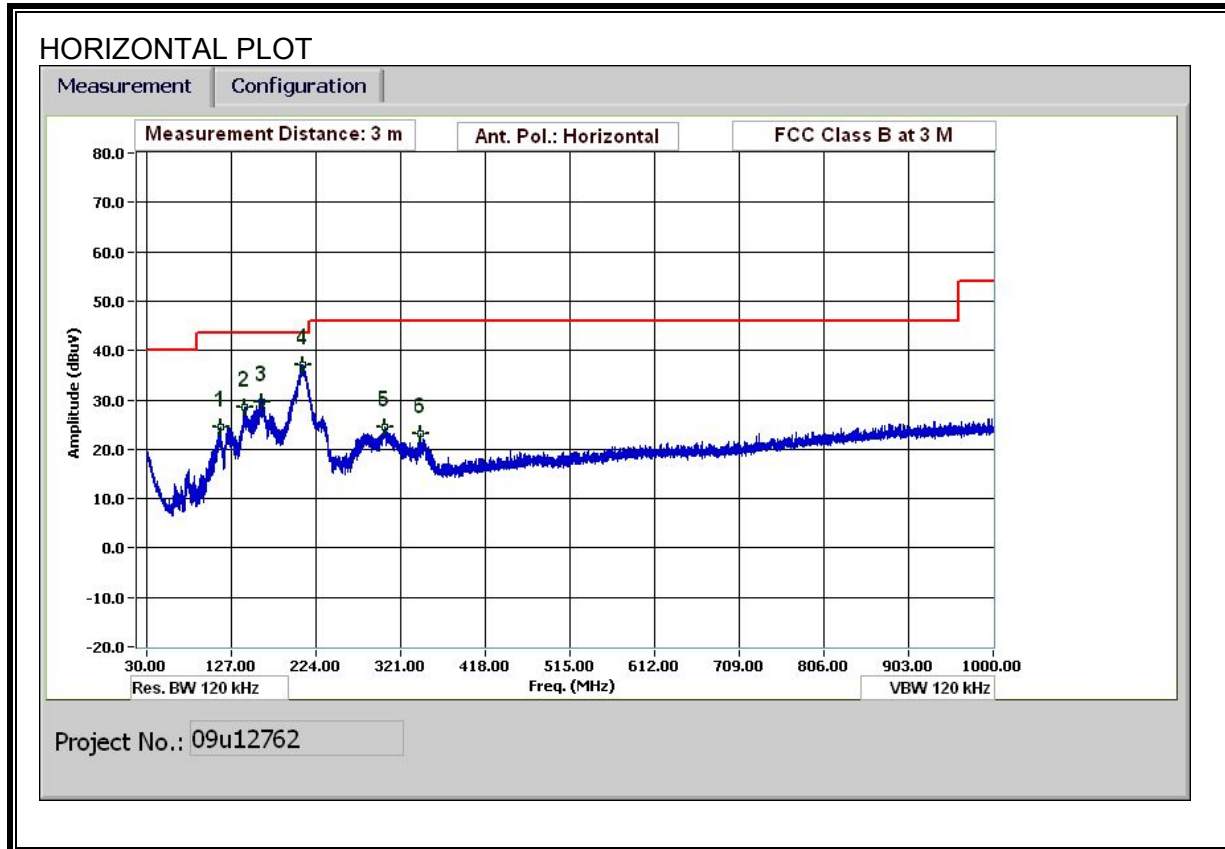

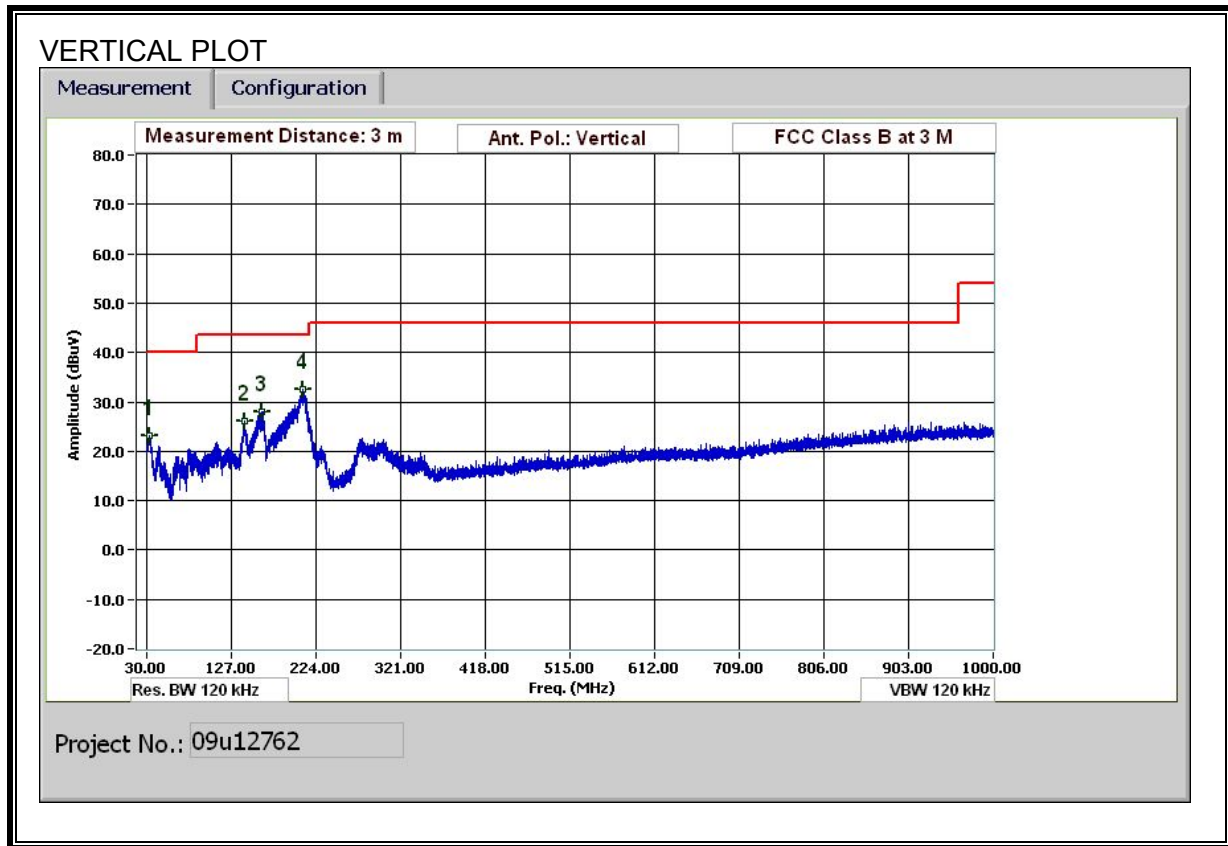

HORIZONTAL AND VERTICAL DATA

30-1000MHz Frequency Measurement
 Compliance Certification Services, Fremont 5m Chamber

Test Engr: Mengistu Mekuria
 Date: 08/12/09
 Project #: 09U12762
 Company: Digital Sun, Inc
 EUT Description: Base Station Receiver
 EUT M/N: 5510-R
 Test Target: FCC Class B
 Mode Oper: Tx Mode

f Measurement Frequency Amp Preamp Gain Margin Margin vs. Limit
 Dist Distance to Antenna D Corr Distance Correct to 3 meters
 Read Analyzer Reading Filter Filter Insert Loss
 AF Antenna Factor Corr. Calculated Field Strength
 CL Cable Loss Limit Field Strength Limit

f MHz	Dist (m)	Read dBuV	AF dB/m	CL dB	Amp dB	D Corr dB	Filter dB	Corr. dBuV/m	Limit dBuV/m	Margin dB	Ant. Pol. V/H	Det. P/A/QP	Notes
33.120	3.0	32.5	18.5	0.5	28.4	0.0	0.0	23.1	40.0	-16.9	V	P	
142.205	3.0	39.9	13.0	1.0	27.9	0.0	0.0	26.0	43.5	-17.5	V	P	
161.765	3.0	41.7	12.9	1.1	27.7	0.0	0.0	28.0	43.5	-15.5	V	P	
209.407	3.0	46.7	11.9	1.2	27.4	0.0	0.0	32.4	43.5	-11.1	V	P	
114.603	3.0	39.5	12.4	0.9	28.1	0.0	0.0	24.6	43.5	-18.9	H	P	
142.205	3.0	42.5	13.0	1.0	27.9	0.0	0.0	28.6	43.5	-14.9	H	P	
162.005	3.0	43.3	12.8	1.1	27.7	0.0	0.0	29.5	43.5	-14.0	H	P	
208.567	3.0	51.4	11.9	1.2	27.4	0.0	0.0	37.2	43.5	-6.3	H	P	
302.891	3.0	36.8	13.5	1.5	27.4	0.0	0.0	24.4	46.0	-21.6	H	P	
343.933	3.0	35.0	14.2	1.6	27.7	0.0	0.0	23.1	46.0	-22.9	H	P	

Rev. 1.27.09

Note: No other emissions were detected above the system noise floor.

7.4. DIGITAL DEVICE BELOW 1 GHz

SPURIOUS EMISSIONS 30 TO 1000 MHz (DIGITAL DEVICE, HORIZONTAL)

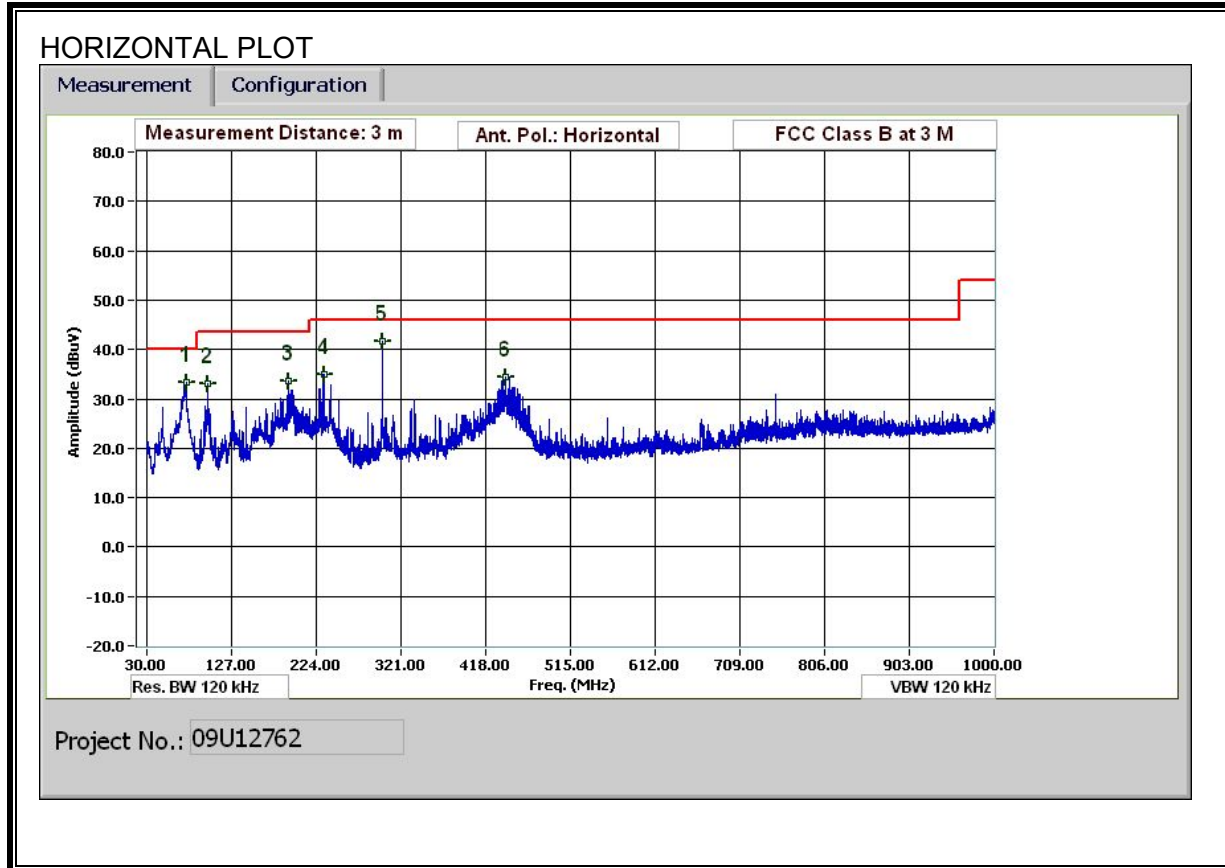

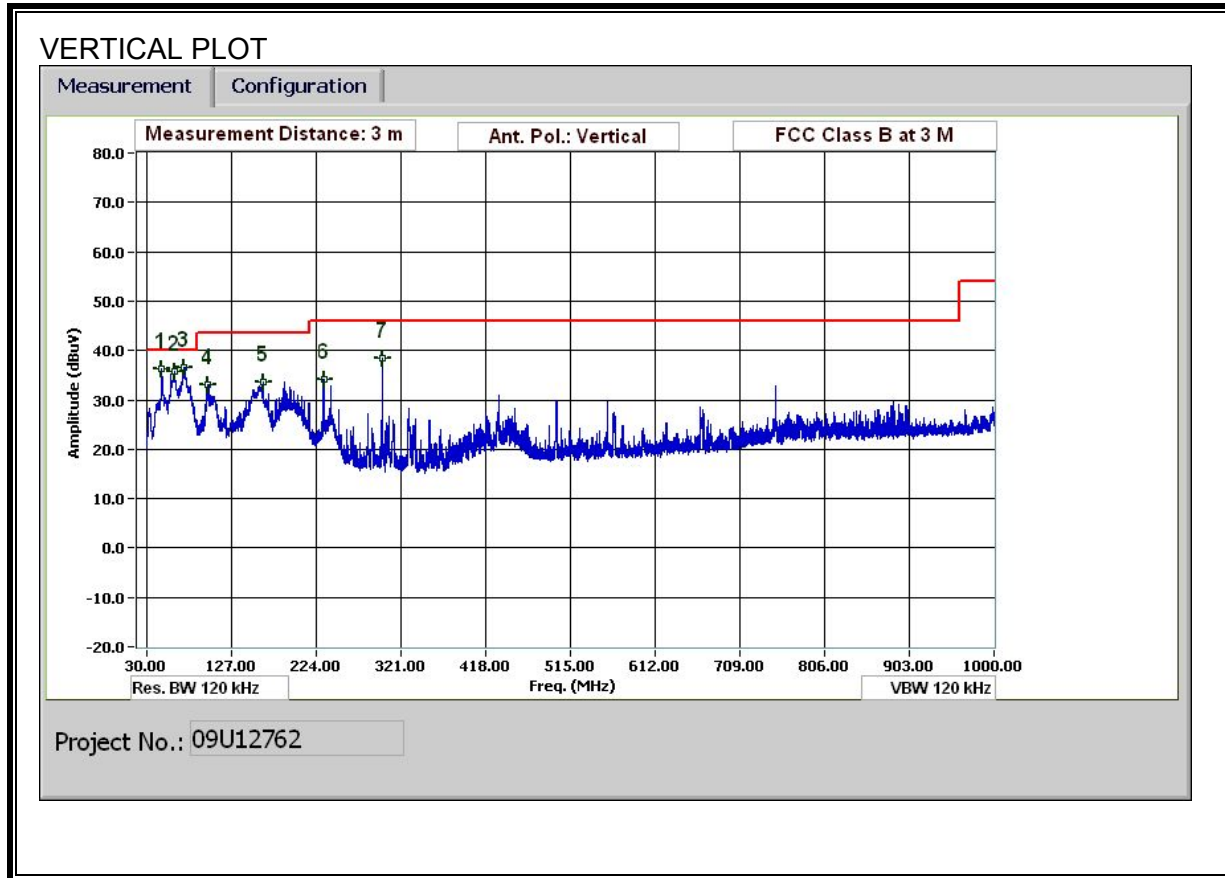

HORIZONTAL AND VERTICAL DATA

30-1000MHz Frequency Measurement
 Compliance Certification Services, Fremont 5m Chamber

Test Engr: Mengistu Mekuria
 Date: 08/12/09
 Project #: 09U12762
 Company: Digital Sun, Inc
 EUT Description: Sensor Probe and Receiver
 EUT M/N: 5510-S and 5510-R
 Test Target: FCC Class B
 Mode Oper: Normal Mode

f	Measurement Frequency	Amp	Preamp Gain	Margin	Margin vs. Limit
Dist	Distance to Antenna	D Corr	Distance Correct to 3 meters		
Read	Analyzer Reading	Filter	Filter Insert Loss		
AF	Antenna Factor	Corr.	Calculated Field Strength		
CL	Cable Loss	Limit	Field Strength Limit		

f MHz	Dist (m)	Read dBuV	AF dB/m	CL dB	Amp dB	D Corr dB	Filter dB	Corr. dBuV/m	Limit dBuV/m	Margin dB	Ant. Pol. V/H	Det. P/A/QP	Notes
47.281	3.0	55.6	9.7	0.6	29.6	0.0	0.0	36.2	40.0	-3.8	V	P	
61.681	3.0	56.7	7.9	0.7	29.6	0.0	0.0	35.7	40.0	-4.3	V	P	
72.962	3.0	57.3	8.1	0.7	29.6	0.0	0.0	36.5	40.0	-3.5	V	P	
99.603	3.0	51.6	10.0	0.9	29.5	0.0	0.0	33.0	43.5	-10.5	V	P	
163.446	3.0	51.1	10.6	1.2	29.3	0.0	0.0	33.6	43.5	-9.9	V	P	
232.448	3.0	49.7	11.9	1.4	28.8	0.0	0.0	34.1	46.0	-11.9	V	P	
299.411	3.0	52.4	13.3	1.6	28.8	0.0	0.0	38.5	46.0	-7.5	V	P	
75.002	3.0	54.2	7.9	0.8	29.6	0.0	0.0	33.3	40.0	-6.7	H	P	
99.963	3.0	51.6	10.1	0.9	29.5	0.0	0.0	33.1	43.5	-10.4	H	P	
191.647	3.0	50.2	11.3	1.2	29.0	0.0	0.0	33.8	43.5	-9.8	H	P	
233.048	3.0	50.6	11.9	1.4	28.8	0.0	0.0	35.0	46.0	-11.0	H	P	
299.411	3.0	55.6	13.3	1.6	28.8	0.0	0.0	41.6	46.0	-4.4	H	P	
440.657	3.0	46.2	15.8	2.0	29.5	0.0	0.0	34.5	46.0	-11.5	H	P	

Rev. 1.27.09

Note: No other emissions were detected above the system noise floor.

8. AC POWER LINE CONDUCTED EMISSIONS

LIMITS

FCC §15.207 (a)

Frequency of Emission (MHz)	Conducted Limit (dBuV)	
	Quasi-peak	Average
0.15-0.5	66 to 56*	56 to 46*
0.5-5	56	46
5-30	60	50

*Decreases with the logarithm of the frequency.

TEST PROCEDURE

ANSI C63.4

RESULTS

6 WORST EMISSIONS

CONDUCTED EMISSIONS DATA (115VAC 60Hz)										
Freq. (MHz)	Reading			Class (dB)	Limit QP	EN B		Margin		Remark L1 / L2
	PK (dBuV)	QP (dBuV)	AV (dBuV)			AV	QP (dB)	AV (dB)		
0.15	39.27	--	1.83	0.00	66.00	56.00	-26.73	-54.17	L1	
4.03	30.09	--	19.58	0.00	56.00	46.00	-25.91	-26.42	L1	
17.29	38.85	--	23.36	0.00	60.00	50.00	-21.15	-26.64	L1	
0.18	39.39	--	4.16	0.00	64.39	54.39	-25.00	-50.23	L2	
4.20	32.13	--	21.67	0.00	56.00	46.00	-23.87	-24.33	L2	
17.38	35.98	--	21.83	0.00	60.00	50.00	-24.02	-28.17	L2	
6 Worst Data										

LINE 1 RESULTS

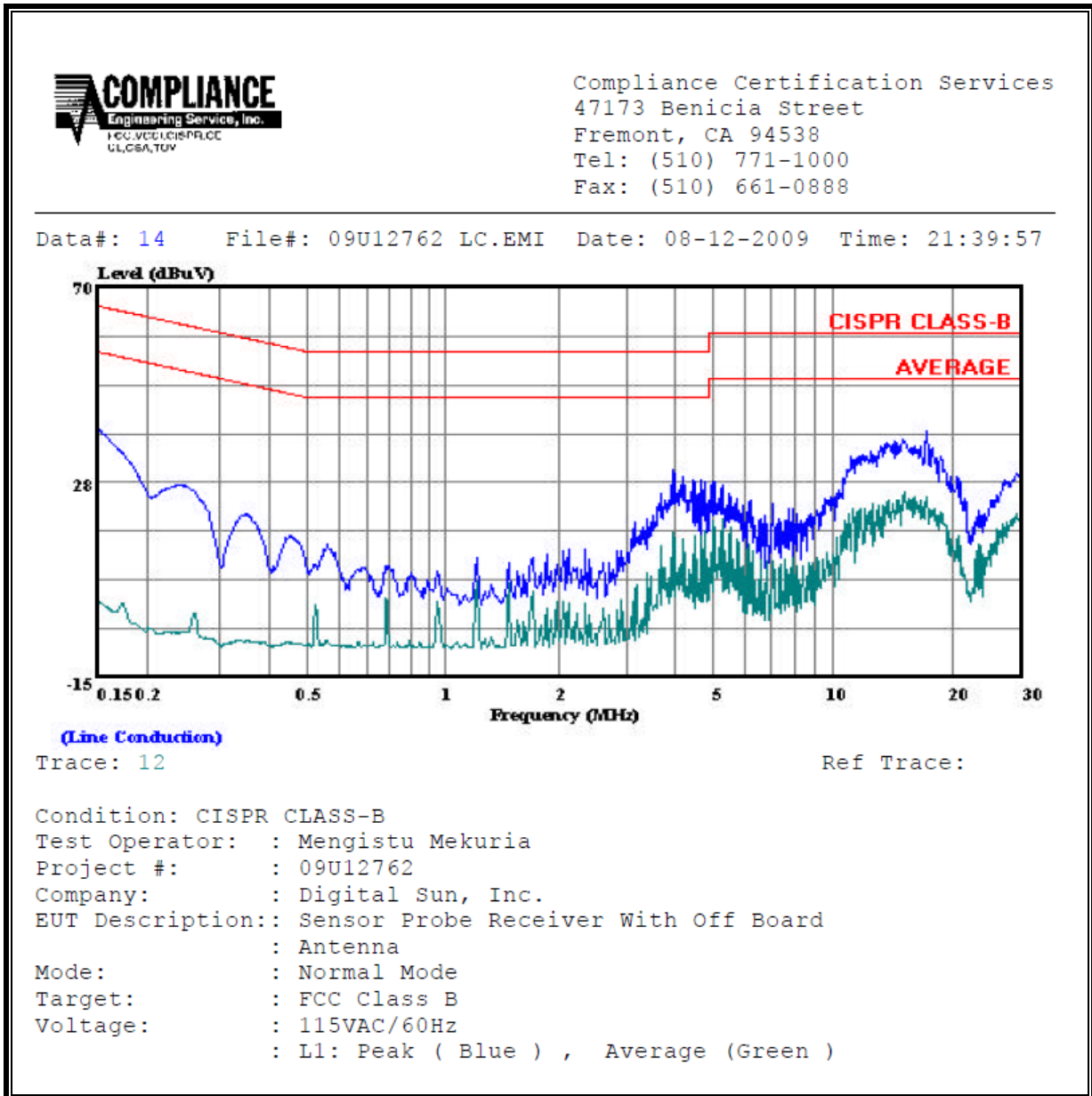

LINE 2 RESULTS

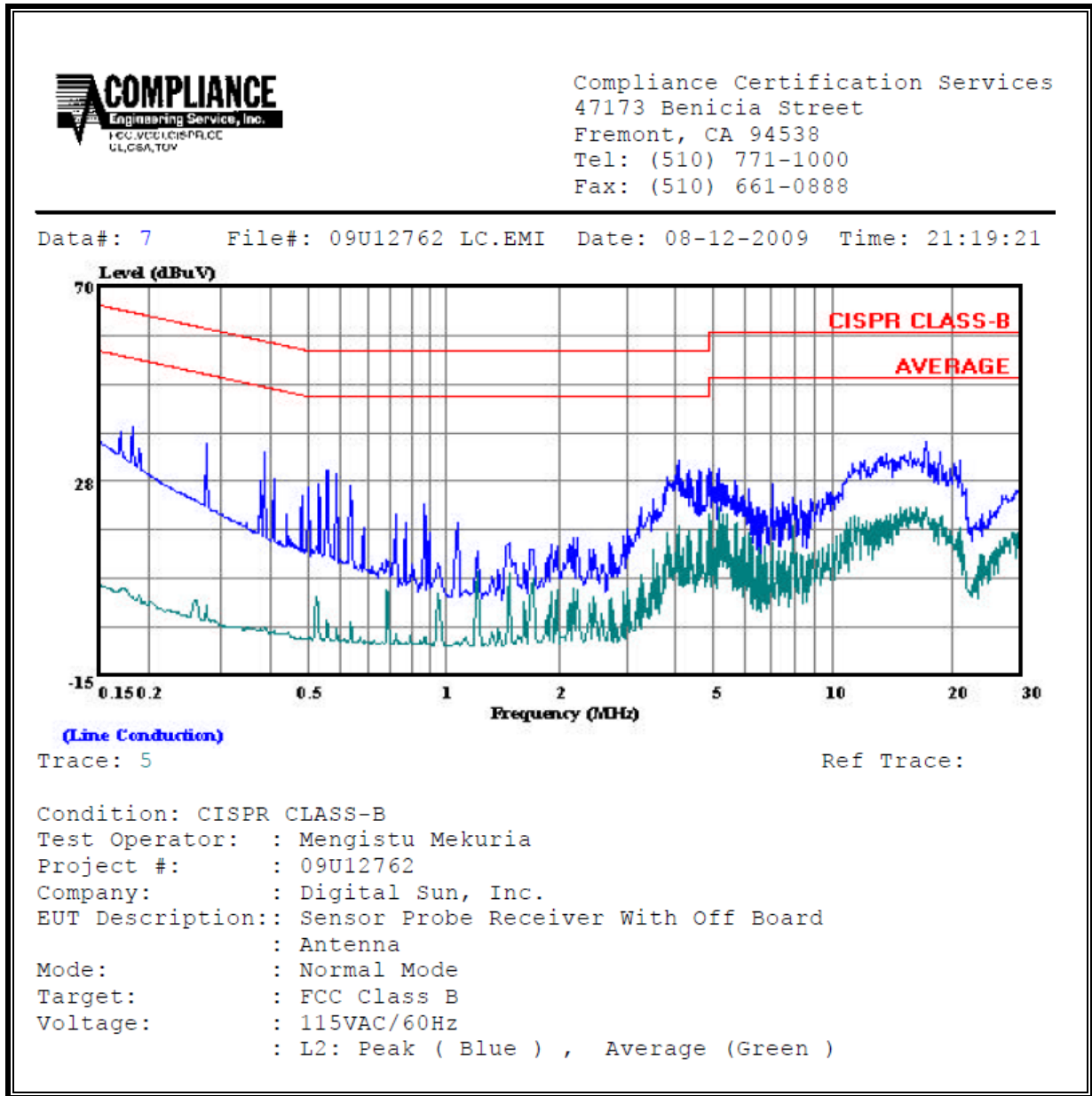

9. MAXIMUM PERMISSIBLE EXPOSURE

FCC RULES

§1.1310 The criteria listed in Table 1 shall be used to evaluate the environmental impact of human exposure to radio-frequency (RF) radiation as specified in §1.1307(b), except in the case of portable devices which shall be evaluated according to the provisions of §2.1093 of this chapter.

TABLE 1—LIMITS FOR MAXIMUM PERMISSIBLE EXPOSURE (MPE)

Frequency range (MHz)	Electric field strength (V/m)	Magnetic field strength (A/m)	Power density (mW/cm ²)	Averaging time (minutes)
(A) Limits for Occupational/Controlled Exposures				
0.3–3.0	614	1.63	*(100)	6
3.0–30	1842/f	4.89/f	*(900/f ²)	6
30–300	61.4	0.163	1.0	6
300–1500	f/300	6
1500–100,000	5	6
(B) Limits for General Population/Uncontrolled Exposure				
0.3–1.34	614	1.63	*(100)	30
1.34–30	824/f	2.19/f	*(180/f ²)	30

TABLE 1—LIMITS FOR MAXIMUM PERMISSIBLE EXPOSURE (MPE)—Continued

Frequency range (MHz)	Electric field strength (V/m)	Magnetic field strength (A/m)	Power density (mW/cm ²)	Averaging time (minutes)
30–300	27.5	0.073	0.2	30
300–1500	f/1500	30
1500–100,000	1.0	30

f = frequency in MHz

* = Plane-wave equivalent power density

NOTE 1 TO TABLE 1: Occupational/controlled limits apply in situations in which persons are exposed as a consequence of their employment provided those persons are fully aware of the potential for exposure and can exercise control over their exposure. Limits for occupational/controlled exposure also apply in situations when an individual is transient through a location where occupational/controlled limits apply provided he or she is made aware of the potential for exposure.

NOTE 2 TO TABLE 1: General population/uncontrolled exposures apply in situations in which the general public may be exposed, or in which persons that are exposed as a consequence of their employment may not be fully aware of the potential for exposure or can not exercise control over their exposure.

EQUATIONS

Power density is given by:

$$S = \text{EIRP} / (4 * \text{Pi} * D^2)$$

where

S = Power density in W/m²
EIRP = Equivalent Isotropic Radiated Power in W
D = Separation distance in m

Power density in units of W/m² is converted to units of mW/cm² by dividing by 10.

Distance is given by:

$$D = \text{SQRT} (\text{EIRP} / (4 * \text{Pi} * S))$$

where

D = Separation distance in m
EIRP = Equivalent Isotropic Radiated Power in W
S = Power density in W/m²

For multiple colocated transmitters operating simultaneously in frequency bands where the limit is identical, the total power density is calculated using the total EIRP obtained by summing the Power * Gain product (in linear units) of each transmitter.

$$\text{Total EIRP} = (P_1 * G_1) + (P_2 * G_2) + \dots + (P_n * G_n)$$

where

P_x = Power of transmitter x
G_x = Numeric gain of antenna x

In the table(s) below, Power and Gain are entered in units of dBm and dBi respectively and conversions to linear forms are used for the calculations.

LIMITS

From FCC §1.1310 Table 1 (B), the maximum value of S = 1.0 mW/cm²

RESULTS

Band	Mode	Separation Distance (m)	Output Power (dBm)	Antenna Gain (dBi)	FCC Power Density (mW/cm ²)
2.4 GHz	802.15.4 Zigbee	0.20	20.31	2.00	0.034