



## USER MANUAL

---

### **Elo Touch Solutions** Elo I-Series Pay 7" Terminal



**Copyright © 2023 Elo Touch Solutions, Inc. All Rights Reserved.**

No part of this publication may be reproduced, transmitted, transcribed, stored in a retrieval system, or translated into any language or computer language, in any form or by any means, including, but not limited to, electronic, magnetic, optical, chemical, manual, or otherwise without prior written permission of Elo Touch Solutions, Inc.

**Disclaimer**

The information in this document is subject to change without notice. Elo Touch Solutions, Inc., and its Affiliates (collectively "Elo") makes no representations or warranties with respect to the contents herein, and specifically disclaims any implied warranties of merchantability or fitness for a particular purpose. Elo reserves the right to revise this publication and to make changes from time to time in the content hereof without obligation of Elo to notify any person of such revisions or changes.





**Trademark Acknowledgments**



Elo, Elo (logo), Elo Touch, Elo Touch Solutions, EloView®, are trademarks of Elo and its Affiliates.







# Table of Contents

<b>Section 1: Introduction</b> .....	10
<b>Product Description</b> .....	10
<b>Important Information</b> .....	10
<b>Terminal Identification (TID)</b> .....	10
<b>Merchant Identification (MID)</b> .....	10
<b>Operator ID</b> .....	10
<b>'Batch' end-of-day banking (settlement)</b> .....	10
<b>Cash Register Interface</b> .....	10
<b>PCI-PTS</b> .....	11
<b>Payment Card Industry Data Security Standard (PCI-DSS) Advice</b> .....	11
<b>Monthly Updates</b> .....	11
<b>Overview – Specifications</b> .....	13
<b>Features: Front View</b> .....	16
<b>Features: Back View</b> .....	17
<b>Section 2: Getting Started</b> .....	18
<b>Unpacking and Initial Inspection</b> .....	18
<b>Micro SD/ PSAM Card Installation</b> .....	19
<b>Charging System &amp; Power</b> .....	21
<b>Charging the Handheld computer through USB type C Port</b> .....	21
<b>Charging Safety Features:</b> .....	错误!未定义书签。
<b>Battery Status / Descriptions</b> .....	错误!未定义书签。

<b>Power Button</b> .....	<b>21</b>
<b>Power LED Status</b> .....	<b>21</b>
<b>Power / Function Buttons Features and Gestures</b> .....	<b>22</b>
<b>Power button On-Screen display menu features</b> .....	<b>22</b>
<b>Gestures</b> .....	<b>22</b>
<b>Status Bar Icons and Definition</b> .....	<b>23</b>
<b>About Touch Gestures</b> .....	<b>24</b>
<b>Out of Box Experience (OOBE) (TBC)</b> .....	<b>25</b>
<b>EloView® Home Screen (TBC)</b> .....	<b>26</b>
<b>EloView® Quick Settings (TBC)</b> .....	<b>27</b>
<b>Lock and Home Screens</b> .....	<b>28</b>
<b>Notification Panel</b> .....	<b>29</b>
<b>Application Drawer</b> .....	<b>32</b>
<b>Customize and add a shortcut to the Home Screen</b> .....	<b>33</b>
<b>Section 3: System Settings</b> .....	<b>34</b>
 <b>Network &amp; Internet</b> .....	<b>34</b>
<b>Wi-Fi</b> .....	<b>34</b>
<b>Mobile Network</b> .....	<b>35</b>
<b>Airplane Mode</b> .....	<b>35</b>
<b>Hotspot &amp; Tethering</b> .....	<b>36</b>
<b>Wi-Fi hotspot</b> .....	<b>36</b>
<b>USB tethering</b> .....	<b>36</b>

<b>Bluetooth Tethering</b> .....	<b>36</b>
<b>Ethernet</b> .....	<b>36</b>
 <b>Connected Devices</b> .....	<b>37</b>
<b>Bluetooth</b> .....	<b>37</b>
<b>Cast</b> .....	<b>37</b>
.....	<b>38</b>
<b>Printing</b> .....	<b>39</b>
<b>USB</b> .....	<b>40</b>
 <b>Apps &amp; Notification</b> .....	<b>41</b>
 <b>Battery</b> .....	<b>44</b>
<b>Battery Saver</b> .....	<b>44</b>
<b>Battery Manager</b> .....	<b>44</b>
<b>Battery Percentage</b> .....	<b>44</b>
 <b>Display</b> .....	<b>45</b>
<b>Auto Idle Mode</b> .....	<b>45</b>
<b>Brightness Level</b> .....	<b>45</b>
<b>Nigh Light Feature</b> .....	<b>45</b>
<b>Adaptive Brightness</b> .....	<b>46</b>
<b>Wallpaper</b> .....	<b>46</b>

<b>Advanced</b> .....	<b>47</b>
<b>Dark theme</b> .....	<b>47</b>
• <b>To switch screen theme on dark (black color) or light (white color), tap Dark.</b> .....	<b>47</b>
<b>Screen timeout</b> .....	<b>47</b>
<b>Auto-rotation screen</b> .....	<b>48</b>
<b>Font size</b> .....	<b>48</b>
<b>Display size</b> .....	<b>48</b>
<b>Screen saver</b> .....	<b>48</b>
<b>Screen Orientation</b> .....	<b>49</b>
<b>Screen Density</b> .....	<b>49</b>
 <b>Sound</b> .....	<b>50</b>
<b>Volumes</b> .....	<b>50</b>
<b>Do not Disturb</b> .....	<b>51</b>
<b>Prevent Ringing</b> .....	<b>52</b>
<b>Default Notification Sound</b> .....	<b>52</b>
<b>Default Alarm Sound</b> .....	<b>53</b>
<b>Screen Locking Sound</b> .....	<b>54</b>
<b>Advanced</b> .....	<b>54</b>
 <b>Storage</b> .....	<b>55</b>
<b>Internal Shared Storage</b> .....	<b>55</b>
<b>Storage Manager</b> .....	<b>55</b>

<b>SD card</b> .....	<b>55</b>
 <b>Elo Settings</b> .....	<b>56</b>
 <b>Wakeup Source</b> .....	<b>56</b>
<b>Permission Manger</b> .....	<b>57</b>
<b>Show Passwords</b> .....	<b>57</b>
<b>Lock Screen</b> .....	<b>57</b>
 <b>Location</b> .....	<b>58</b>
 <b>Security</b> .....	<b>59</b>
<b>Screen Lock</b> .....	<b>59</b>
<b>Swipe Security</b> .....	<b>59</b>
<b>Pattern Security</b> .....	<b>59</b>
<b>Pin Security</b> .....	<b>60</b>
<b>Password Security</b> .....	<b>61</b>
 <b>Accounts</b> .....	<b>62</b>
 <b>Accessibility</b> .....	<b>63</b>
 <b>System</b> .....	<b>64</b>
<b>Languages &amp; Input</b> .....	<b>64</b>

<b>Gestures</b> .....	65
<b>Date &amp; Time</b> .....	66
<b>Advanced</b> .....	67
<b>Reset options</b> .....	67
<b>Multiple users</b> .....	67
<b>To switch users</b> .....	67
<b>To add user</b> .....	67
<b>To delete guest from the device</b> .....	67
<b>To rename Admin Profile info</b> .....	68
 <b>About Device</b> .....	69

<b>Section 4: Operational</b> .....	70
<b>About Camera App</b> .....	70
<b>Camera Features</b> .....	70
<b>Video Features</b> .....	72
<b>Take a Picture and Record Video</b> .....	74
<b>About  File Application</b> .....	75
<b>Delete Files</b> .....	75
<b>Copy and Move Files</b> .....	76
<b>Share Files</b> .....	76
<b>Scanning QR code with Integrated Camera</b> .....	77
<b>NFC / EMV</b> .....	78



<b>SCR</b> .....	79
<b>MSR</b> .....	80
<b>About Elo Mobile Factory Full Reset</b> .....	81
Section 5: Maintenance and Troubleshooting .....	82
<b>Elo Mobile POS Care and Handling</b> .....	82
Section 6: Elo Service and Support .....	83
<b>Elo Service and Support</b> .....	83
<b>Returning a Terminal for Service</b> .....	83
Section 7: Regulatory Information.....	84
<b>Electrical Safety Information</b> .....	84
<b>Emissions and Immunity Information</b> .....	84
Radio Equipment Directive .....	86
<b>Agency Certifications</b> .....	88
Waste Electrical & Electronic Equipment Directive (WEEE).....	89
<b>Electronic Regulatory Labels</b> .....	89
Power Specifications.....	90
Section 8: Warranty Information .....	91
Visit our website <b>www.elotouch.com</b> for the latest information below:.....	91

# Section 1: Introduction

## Product Description

Thank you for choosing Elo I-Series Pay 7" terminal, it delivers an enterprise-grade, Android POS computer ready to help you assist customers. This all-in-one device offers built-in capabilities to accept payments, conduct business, and track sales all from the palm of your hand. Complete with a 7-inch HD touch display, integrated payment, flexible Android 12 OS, and Qualcomm 660 octa-core processor, the I-Series Pay 7" terminal provides seamless integration, effortless provisioning, and simplified device management via EloView® or your preferred 3<sup>rd</sup> party MDM.

With rugged Corning Gorilla Glass technology to provide protection against unintentional spills, the I-Series Pay 7" is purpose-built to endure commercial use. From table service and line busting to curbside pickup and accepting payment almost anywhere, Elo's I-Series Pay 7" allows your employees to be ready on the go.

## Important Information

### Terminal Identification (TID)

Each terminal contains an electronically programmed eight-digit number known as a Terminal Identification (TID). This is printed in full on the merchant's copy of all transaction receipts.

### Merchant Identification (MID)

Your bank will have issued you with a MID, supplied in a separate documentation pack directly from them. If you do not have this number, please contact your bank.

Before taking transactions, you should confirm the MID printed on your Terminal Report matches the MID issued by your bank. If not, please contact your helpdesk.

You may have separate the MIDs for American Express, Diners Club, JCB and, and Duet cards, and the mobile Top Up service, if you have requested these.

### Operator ID

Your terminal may require you to input an Operator ID during a Voice Referral transaction. The Operator ID will be provided by the Authorization center.

RECEIPT: The inclusion of a \*symbol printed on the Merchant Copy of the transaction receipt indicates that the transaction was authorized using the Voice Referral process.

### 'Batch' end-of-day banking (settlement)

At the end of each business day, the Settlement procedure must be performed on the terminal. If you do not complete this procedure, you may experience delays in funds being transferred to your bank account.

### Cash Register Interface

If you have an SP terminal or PIN Pad integrated with your cash register/till system, many of the functions of the terminal will be carried out by cash register functions.

Certain functions described in this user manual may not be available via the cash register interface.

If your terminal operates in conjunction with a cash register, your head office or the product manufacturer will have provided additional instructions.

## **PCI-PTS**

PCI SSC's approval only applies to PEDs that are identical to the PED tested by a PCI Security Standards Council recognized laboratory. If any aspect of the PED is different from that which was tested by the laboratory – even if the PED conforms to the basic product description contained in the letter — the PED model should not be considered approved, nor promoted as approved. For example, if a PED contains firmware, software, or physical construction that has the same name or model number as those tested by the laboratory, but in fact are not identical to those PED samples tested by the laboratory, then the PED should not be considered or promoted as approved.

No vendor or other third party may refer to a PED as "PCI Approved," nor otherwise state or imply that PCI SSC has, in whole or part, approved any aspect of a vendor or its PEDs, except to the extent and subject to the terms and restrictions expressly set forth in a written agreement with PCI SSC, or in an approval letter. All other references to PCI SSC's approval are strictly and actively prohibited by PCI SSC. When granted, an approval is provided by PCI SSC to ensure certain security and operational characteristics important to the achievement of PCI SSC's goals, but the approval does not under any circumstances include any endorsement or warranty regarding the functionality, quality, or performance of any particular product or service. PCI SSC does not warrant any products or services provided by third parties. Approval does not, under any circumstances, include or imply any product warranties from PCI SSC, including, without limitation, any implied warranties of merchantability, fitness for purpose or non-infringement, all of which are expressly disclaimed by PCI SSC. All rights and remedies regarding products and services, which have received an approval, shall be provided by the party providing such products or services, and not by PCI SSC or the payment brand participants.

## **Payment Card Industry Data Security Standard (PCI-DSS) Advice**

### **Monthly Updates**

Once a month, your terminal will connect to the Elo Terminal Management System to download new software and important configuration changes. This update will typically occur overnight. For this reason, it is suggested that your terminal be powered on at all times. For POS terminals, it is recommended for the device to be left on the charging stand or connected to the power supply when not in use. In the event that the terminal is powered off when the update takes place, or having a low battery in the case of portable models, the system will notify you that the update has failed. Please leave your terminal on the following night to ensure the upgrade is completed or call your helpdesk for assistance.

The Elo I-Series Pay 7" terminal contains a payment application that stores, processes and transmits cardholder data. It therefore falls within the scope of the Payment Card Industry Data Security Standards (PIC-DSS).

This section contains advice to assist you with PCI-DSS compliance.

Please note it is the responsibility of the merchant to ensure the merchant copies of receipts and reports showing cardholder details are stored securely for the period of time specified by your bank. Please also ensure they are disposed of in a secure manner at the end of that period. Failure to do so may result in charge-backs or fraudulent activity.

## **1. Retention of full magnetic strip, card validation code or PIN block data**

The payment application within the Elo I-Series Pay 7" terminals does not retain card data. You need to take no further action to ensure your PCI DSS compliant environment meets this specific requirement.

## **2. Protection of stored cardholder data**

The payment application within the Elo I-Series Pay 7" terminals protect stored cardholder data in a secure manner.

You must ensure you give the correct copy of the receipt to the cardholder (clearly marked CARDHOLDER COPY) and retain the merchant receipts in a secure area with limited access to authorized staff. The merchant receipts must be destroyed by incineration or by cross-shredding when they become obsolete. Your bank will advise on the period necessary for retention of receipts.

You should perform an End of Day Banking/Settlement every day. Your terminal may be configured to perform this process automatically every day; if you are unsure how your terminal is configured, please contact your helpdesk.

## **3. Provision of secure authentication features**

The payment application operates in the Elo I-Series Pay 7" terminal hardware environment and does not require username or password access. You need take no further action to ensure your PCI DSS compliant environment meets this specific requirement.

## **4. Secure payment applications**

The Elo I-Series Pay 7" terminal and its software applications have been designed in line with PCI DSS and industry best practices. You need take no further action to ensure your PCI DSS compliant environment meets this specific requirement.

## **5. Protection of wireless transmissions**

The Elo I-Series Pay 7" terminal utilizes Wi-Fi wireless transmissions in accordance with PCI DSS and industry best practices.

## **6. Testing payment applications to address vulnerabilities**

Elo have a process to identify newly discovered security vulnerabilities and have timely development and deployment of security patches and upgrades. You need take no further action to ensure your PCI DSS compliant environment meets this specific requirement.

## **7. Secure network implementation**

The payment application operates in the Elo I-Series Pay 7" terminal hardware environment and does not need to log application activity.

## **8. Ensuring cardholder data must never be stored on a server connected to the Internet**

If you are using the Elo I-Series Pay 7" device on a Local Area Network for the payment transaction interface and you are using a local server to store and forward the transaction data, you must take steps to protect the transaction data in accordance with DSS requirements.

## **9. Secure remote software updates**

Software updates will be carried out automatically by the Elo Terminal Management System. This system ensures only authenticated payment software is loaded onto your terminal.

## 10. Secure remote access to payment application

There is no remote access to the payment application.

## 11. Encryption of sensitive traffic over public networks

Transactions sent over network connections are always encrypted by the payment application using Secure Socket Layer (SSL) technology.

You must never communicate sensitive cardholder data by any means unless it is encrypted. Elo will never request such data from you.

Sensitive cardholder data means:

- The Card Number (often known as Primary Account Number or PAN),
- The Cardholder Name, the Card Expiration Date,
- The Card CV2 Number (the last three digits printed on the card signature strip, or for American Express, the four-digit value printed on the front of the card).

Your helpdesk may request the first six digits of a card number from you to assist with troubleshooting a problem. This should be provided along with the name of the card issuer when requested, to enable your helpdesk to assist.

You will not be asked for a full card number by your helpdesk.

## 12. Encrypt all non-console administrative access

This is not applicable to the Elo payment application.

## 13. Maintain instructional documentation/training programs for cardholders, resellers, & integrators

As well as the information in this user manual, Elo will make available to you via its website [www.elotouch.com](http://www.elotouch.com) for further information regarding PCI DSS compliance.

## Overview – Specifications

	<b>I-Series Pay 7"</b>
<b>Enclosure Color</b>	Black
<b>Operating System</b>	Android 12 with Google Play Services
<b>Processor</b>	Qualcomm Snapdragon 660 2.2GHz Octa-Core Processor
<b>Memory</b>	4GB
<b>Storage</b>	64GB
<b>Display</b>	7" Optically bonded high-definition LED 1920*1080 400 nits typ. 1000:1 contrast ratio typ.
<b>Touch Screen</b>	Projective capacitive with Corning Gorilla Glass Water rejection

<b>Front Camera</b>	1x 5MP, Fixed Focus
<b>Sensors</b>	Accelerometer (automatically adjust display orientation)
<b>Extended Storage</b>	1x MicroSD slot
<b>PSAM</b>	2x PSAM card slot
<b>I/O Ports</b>	USB Type-C for display, charging and data
<b>Payment</b>	EMV Contactless ISO 14443-A/B, MiFare, ISO-18092 EMV Chip Card Reader 3-Track MSR ISO 7810/7811
<b>Certifications / Supported Payment Schemes</b>	<ul style="list-style-type: none"> <li>• PCI-PTS V6.2 (In progress)</li> <li>• EMV L1 &amp; L2 (In progress)</li> <li>• Visa PayWave (In progress)</li> <li>• MasterCard Contactless (In progress)</li> <li>• Amex ExpressPay (In progress)</li> <li>• Discover D-PAS (In progress)</li> <li>• UnionPay QuickPass (In progress)</li> <li>• JCB Jspeedy (In progress)</li> <li>• TQM (In progress)</li> <li>• Interac Flash (In progress)</li> <li>• EFTPOS (In progress)</li> <li>• Common SECC / UKCC (In progress)</li> </ul>
<b>Wireless</b>	IEEE 802.11a/b/g/n/ac with 2x2 MU-MIMO
<b>Bluetooth</b>	Bluetooth 5.0
<b>LED</b>	1x Amber/White LED for power RGBW LED for EMV-CL reader RGBW LED for SCR reader
<b>Keyboard</b>	On screen keyboard
<b>Audio</b>	1x Microphone 1x 1W Speaker 1x Buzzer
<b>Buttons</b>	1x Power button 1x Home button
<b>Dimensions</b>	TBC" x TBC" x TBC" / TBC mm x TBC mm x TBC mm
<b>Shipping Box Dimensions</b>	TBC" x TBC" x TBC" / TBC mm x TBC mm x TBC mm
<b>Gross Weight</b>	TBC lbs / TBC g
<b>Net Weight</b>	TBC lbs / TBC g
<b>Temperature</b>	Operating: 0°C to 40°C (32°F to 104°F)

	Storage: -20°C to 50°C (-4°F to 122°F)
Humidity	5% to 90% non-condensing
Regulatory Approvals and Declarations	<ul style="list-style-type: none"> <li>UL, FCC (US) – Class B (In progress/TBC)</li> <li>cUL, IC (Canada) (In progress/TBC)</li> <li>CB (International safety) (In progress/TBC)</li> <li>CE (Europe) – Class B (In progress/TBC)</li> <li>RCM (Australia) (In progress/TBC)</li> </ul>
ESD	8kV contact, 15kV air, Class-A(In progress/TBC)
Ingress Protection/Sealing	IP54 to the front facing side per IEC standard 60529

## Features: Front View

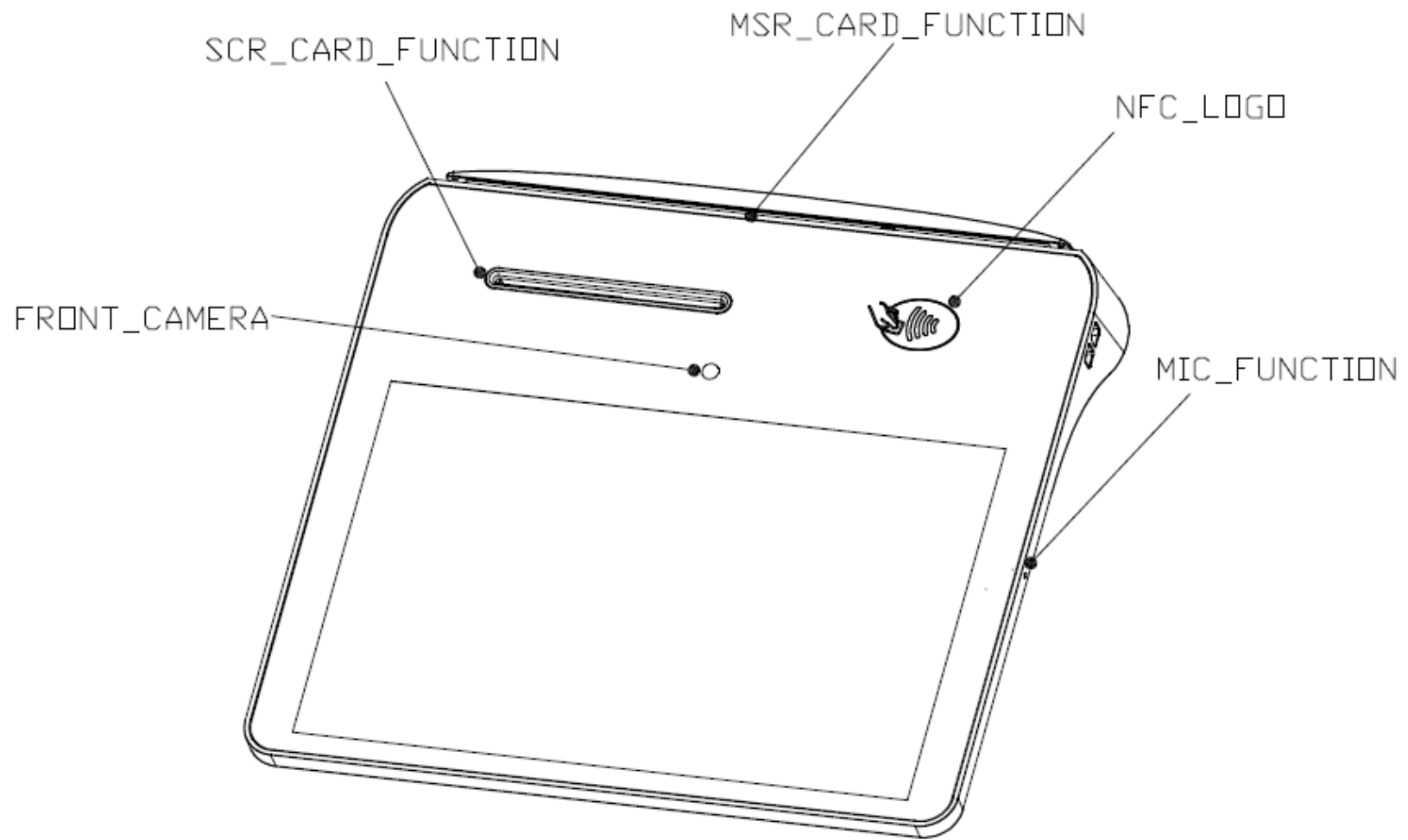



## Features: Back View

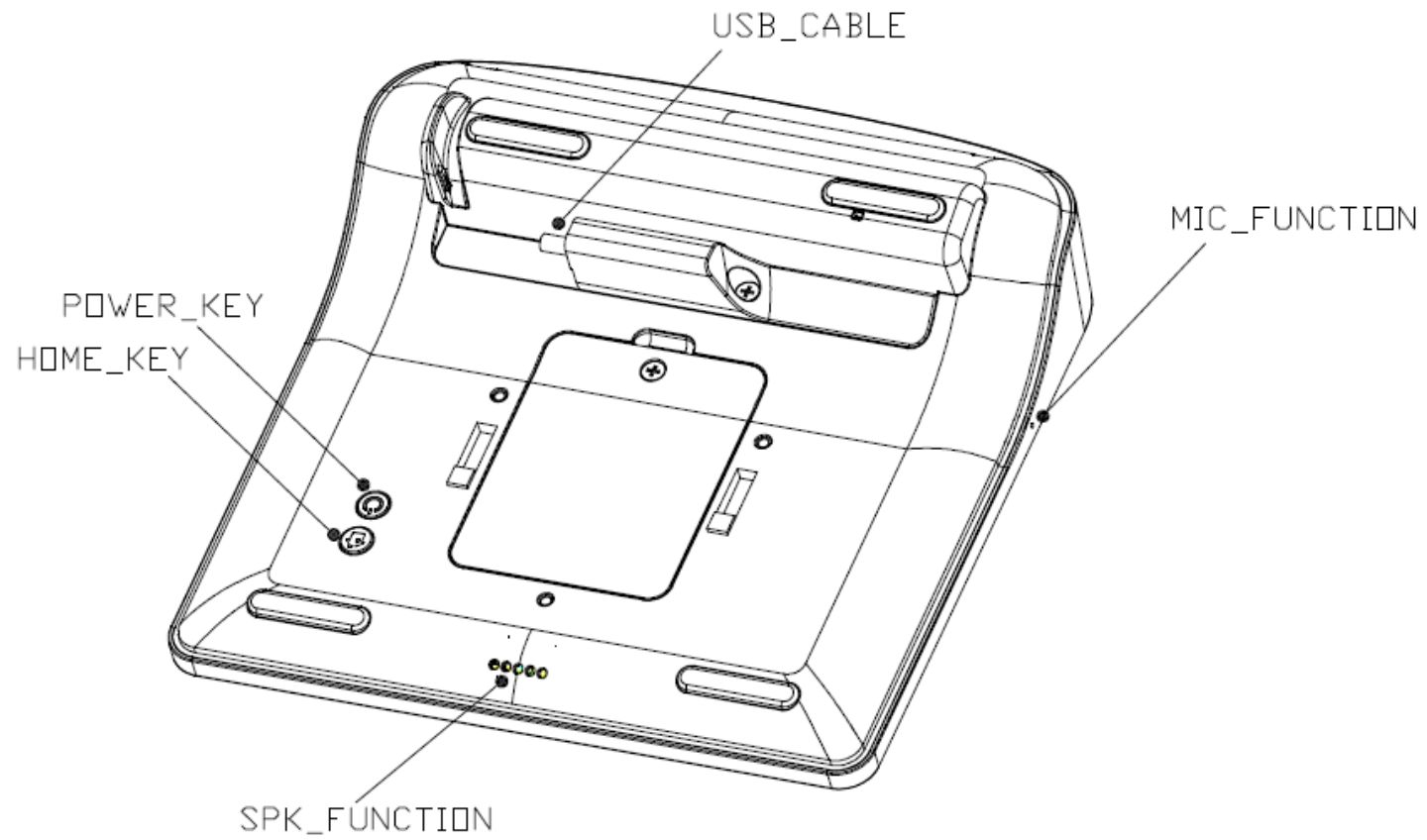

# Section 2: Getting Started

## Unpacking and Initial Inspection

The I-Series Pay 7" terminal fulfills PCI-PTS security requirements. Upon receipt of your device, the following inspection should be performed.

- Check if any damage on the shipping carton.
- Open the carton box and verify all contents listed below are included in the box:
  - ❖ Elo I-Series Pay 7" Terminal.
  - ❖ USB-C Power Adapter.
  - ❖ Quick Install Guide.
- Check if the information (product name, serial number, etc.) matches the delivery information.
- Remove all protective material, plastic wrapping from the device, inspect the device carefully if any damage or signs of tampering.
  - ❖ Inspect the security seals and labels to make sure no signs of peeling or tampering.
  - ❖ Inspect chip card acceptor to make sure that there's no untoward obstruction(s) or suspicious objects at the opening.
  - ❖ Inspect MSR slot to make sure that there is no other additional reader or inserted object(s).
  - ❖ Inspect appearance of device to make sure that there is no tamper evidence. It is important to review especially in the touchscreen area.
  - ❖ Power on the device, check if any tamper warning message shown on the screen and make sure the red LED in the front is not turned on.
  - ❖ Inspect the HW/FW version and check if it runs well.

**Note:** Keep the packing material and shipping carton, which must be re-used whenever the device is shipped.



**Do not use a device that has been damaged or tampered with. The Elo I-Series Pay 7" terminal comes equipped with tamper-evident label(s). If any of the label or components appears damaged, please notify the shipping company and your Elo representatives or service provider immediately.**

## USBC Cable Installation

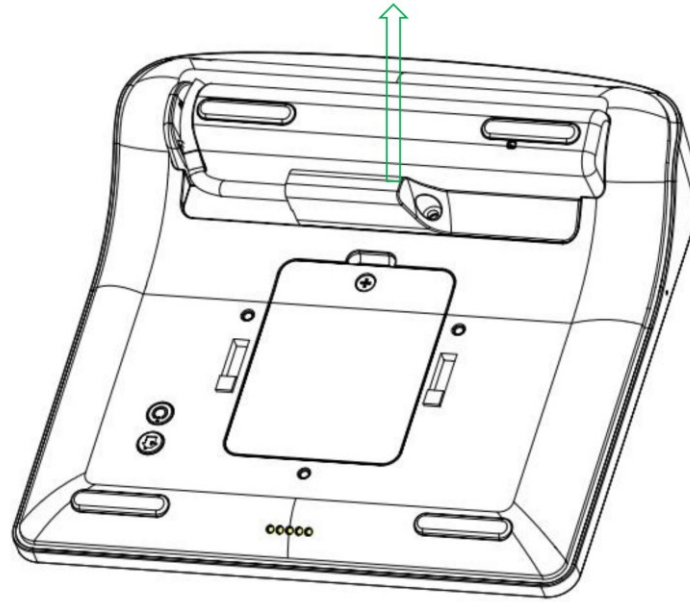

1. turn off the crew
2. Turn up the USB\_COVER

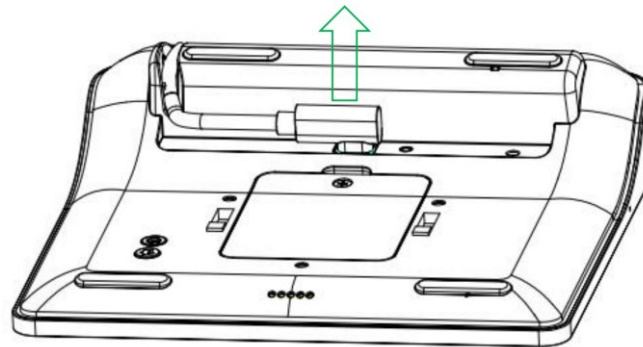

Push the USB\_CABLE follow green arrow

## Micro SD/ PSAM Card Installation

- First save files and shutdown the terminal.

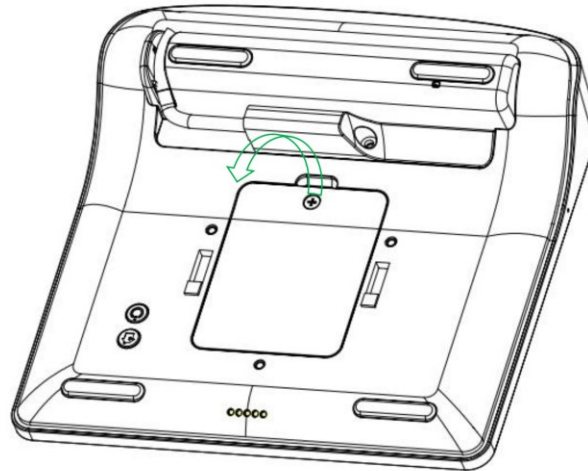

Turn up the PSAM-COVER

- Unscrew and remove the plastic cover over the card slots.

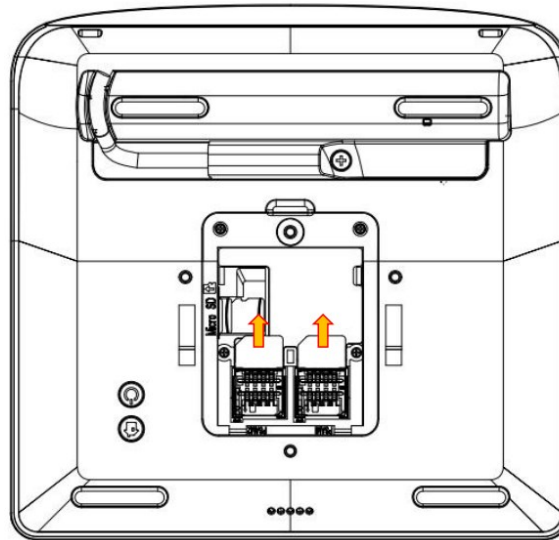

PSAM is pushed out in the arrow direction,

## System & Power

### Charging the Handheld computer through USB type C Port

- The Elo I-Series Pay 7" terminal is powered by a rechargeable battery (Li-ion polymer Battery). A charger (USB-C type wall adapter) is included with the computer.
- With Qualcomm Quick Charge 4.0 a charge to 90% will take about 60 – 90 minutes.

### Power Button

**Note:** If any reason the device does not display video while it is charging. Press the power button once and if battery icon  appears into the display screen it means it is in the OFF state.

- To turn ON the power of mobile POS press and hold power button for 2 seconds.
- To Shut down or Restart, press and hold the power button for more than 5 seconds and follow the on-screen display menu.
- To force the system to Shut down, press and hold the power button for 12 seconds.
- To bring the system out of sleep/standby mode, press the power button once or touch the screen.

### Power LED Status

POWER LED STATUS	DESCRIPTION
OFF	OFF
Solid White	Power ON
Solid Amber	Power ON, Suspended

### Home Button

- To return to Android Home, press the Home button once.

## Power / Function Buttons Features and Gestures

### Power button On-Screen display menu features

If the power button is pressed for more than 5 seconds, a pop-up screen menu will appear.

#### Android Home

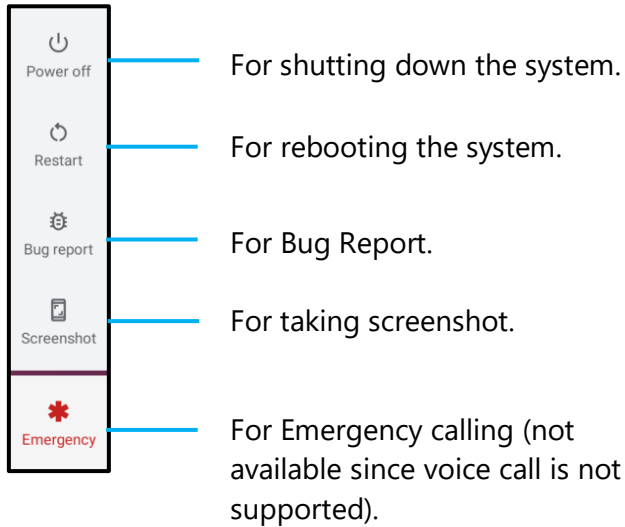

#### EloView®

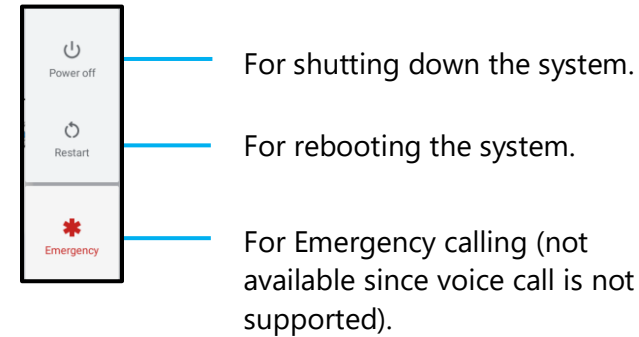





















### Gestures

**Note:** The following gesture will only work if the programmable function buttons are set as "Volume up and down". See [Key Remap](#) from Settings.

- Pressing power button twice will activate Camera.
  - ❖ To enable or disable this feature see *Settings on System* → *Gesture on this user manual*.

## Status Bar Icons and Definition

	Connected to GPRS mobile network		Roaming
	GPRS in use		No signal
	Connected to EDGE mobile network		No SIM card installed
	EDGE in use		Vibrate mode
	Connected to 3G mobile network		Ringer is silenced
	3G in use		Phone microphone is mute
	Mobile network signal strength		Battery is very low
	Connected to a Wi-Fi network		Battery is low
	Bluetooth is on		Battery is partially drained
	Connected to a Bluetooth device		Battery is full
	Airplane mode		Battery is charging
	Alarm is set		GPS is on
	Speakerphone is on		Receiving location data from GPS
	New Gmail message		More notifications
	New text or multimedia message		Call in progress
	Problem with text or multimedia message delivery		Call in progress using a Bluetooth headset
	New Google Talk message		Missed call
	New voicemail		Call on hold
	Upcoming event		Call forwarding is on
	Data is syncing		Song is playing
	Problem with sign-in or sync		Uploading data
	SD card or USB storage is full		Downloading data
	An open Wi-Fi network is available		Download finished
	Phone is connected via USB cable		Connected to or disconnected from virtual private network (VPN)
	Phone is sharing its data connection via USB (USB tethering)		Carrier data use threshold approaching or exceeded
	Phone is sharing its data connection as a Wi-Fi hotspot (Wi-Fi tethering)		Application update available
	Phone is tethered in multiple ways		System update available

## About Touch Gestures



### Tap

Briefly touch surface with fingertip



### Press

Touch surface for an extended period of time.

### Press and Hold / Touch and Hold

Touch surface for an extended period of time and continue to hold the finger against the screen.

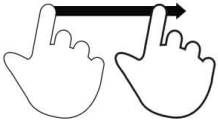

### Drag

Move fingertip over surface without losing contact.



### Flick

Quickly swipe surface with fingertip.

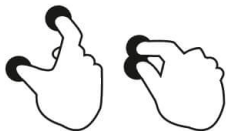

### Spread - Zoom in

Touch surface with two finger and move them apart.



### Pinch - Zooming out

Touch surface with two fingers and bring them closer together.



## Out of Box Experience (OOBE) (TBC)

### Step 1:

- Choose the following set up method.

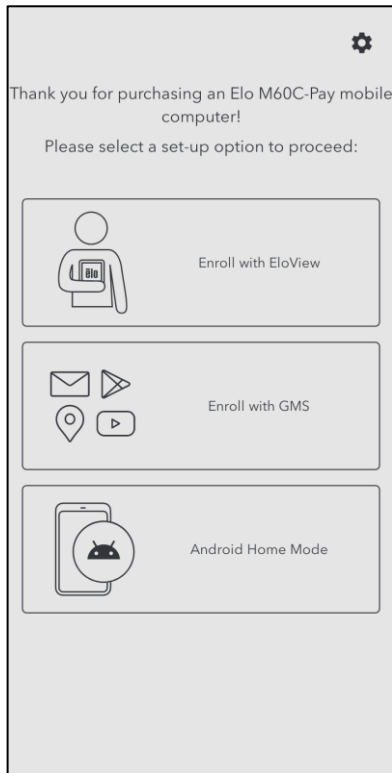

### Step 2:

- Follow on-screen instructions to complete the setup.
- To enroll with EloView® you must connect to Wi-Fi.

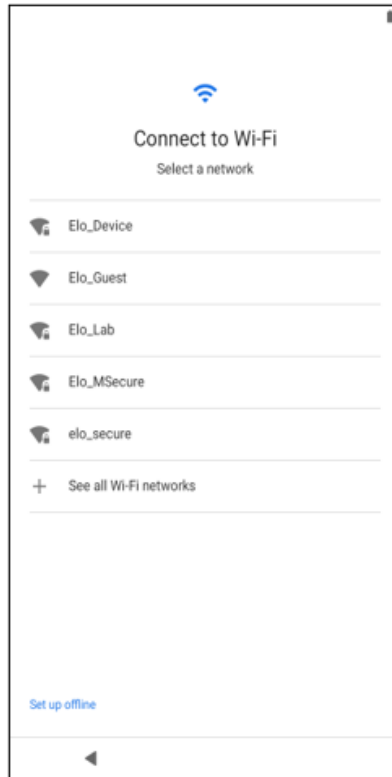

### Step 3:

- EloView® Home (screen locked at default).

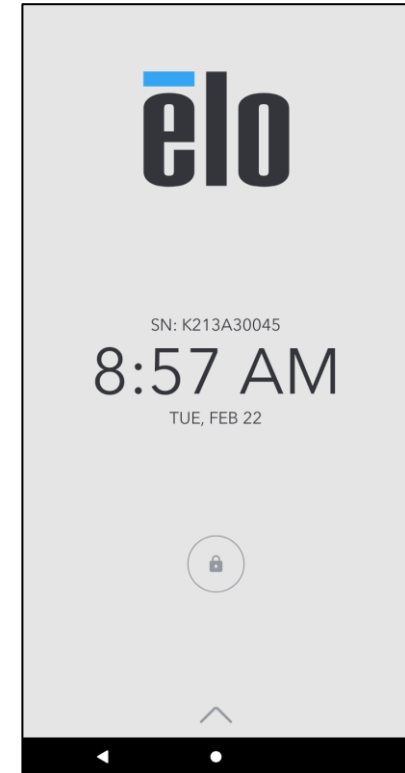

## EloView® Home Screen (TBC)

The EloView® Home Screen is the starting point for navigating of the device. You can place your favorite apps and widgets here.

**Note:** The images below may appear differently on your mobile POS device.

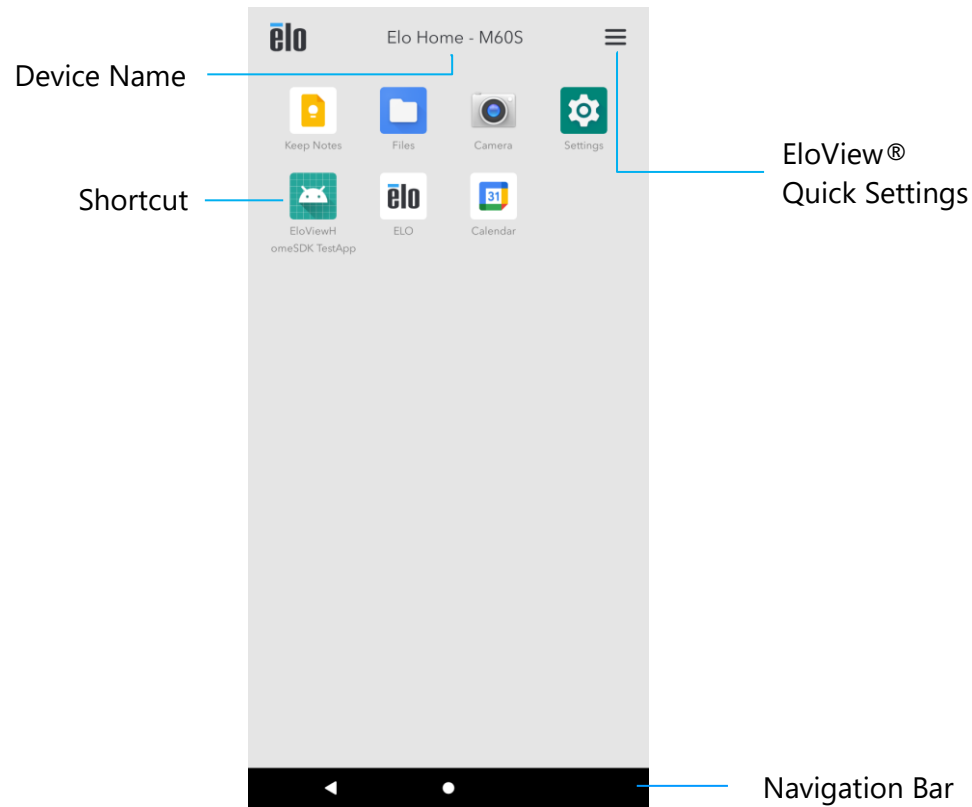

### Navigation Bar

 **Back** - Return to the previous page.

 **Home** - Return to the home screen.

## EloView® Quick Settings (TBC)

To access the Quick Settings, tap  3 lines menu from EloView® Home Screen. Located on the upper right side.

### Settings:

- Wi-Fi
- Bluetooth
- Battery
  - ❖ Tap an Icon once to enable or disable.
  - ❖ Press and hold an Icon to access the settings.

### Volume

- Move slide bar Left or Right to adjust the volume.

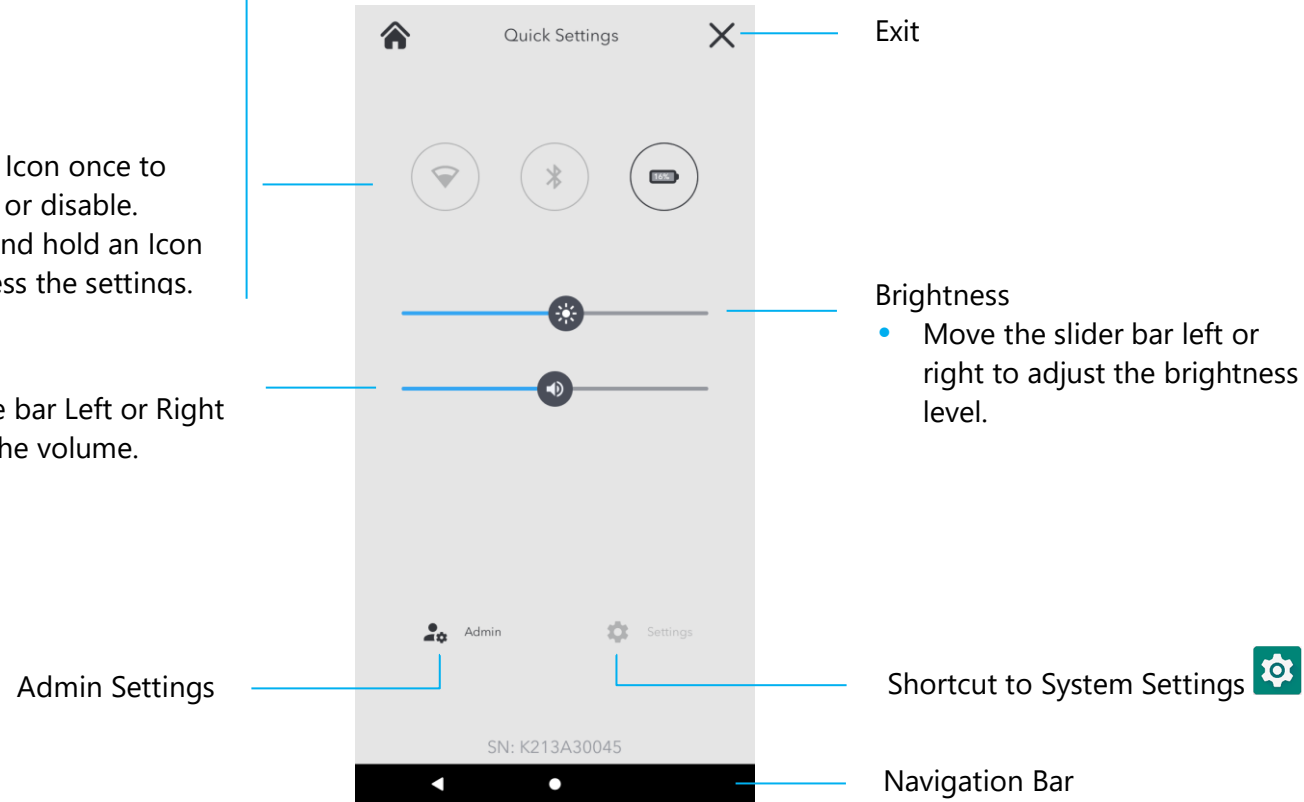

# Lock and Home Screens

**Note:** The images below may appear differently from the actual computer.

## Lock Screen

Time & Date

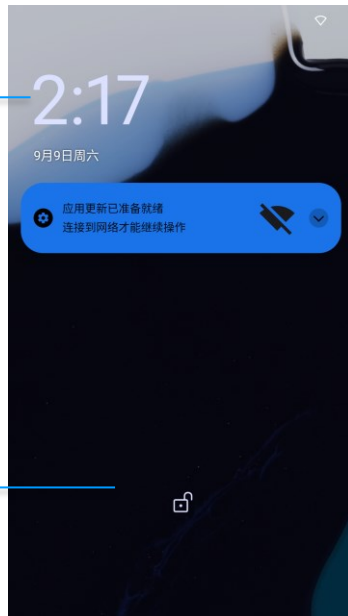

Lock Feature

## Home

Notifications

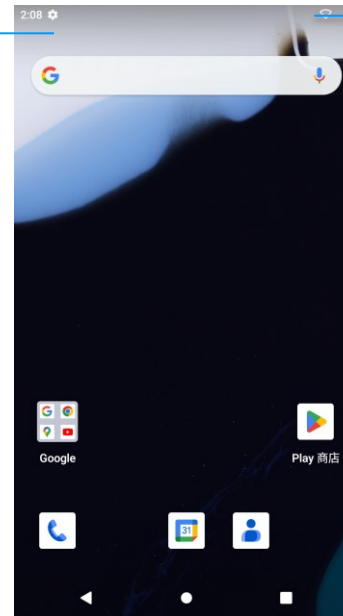

Status Bar



**Home Screen** is the starting point for navigating the computer. You can place your favorite apps and widgets here.

- To unlock the screen to **Home Screen**, swipe up on the **Lock Screen**.

**Note:** The default security is Swipe. Refer to Security settings section in this manual for advanced settings.

- To Lock the screen, press the power button once.

## Navigation Bar

-  **Recent App** - Return to the previous page.
-  **Home** - Return to the home screen.
-  **Back** - Switch between recently used apps.

## Notification Panel

The notification panel allows for quick access to setting shortcuts and notification alerts.

**Note:** The images below may appear differently from the actual computer.



## To open the Notification Panel

- From the **Home Screen**, swipe down from the top of the touch screen.
- To clear a single notification alert, drag the notification all the way to the left or right.
- To clear all notification alerts, tap "**Clear**".
- To customize notification alerts, drag the notification halfway to the left or right then tap  setting.
- To exit tap **Navigation Bar** feature or swipe up the notification alert menu.

## Quick Access Panel

Access Panel allows for quick access frequently used settings, Brightness, and a shortcut to System Settings.

**Note:** The images below may appear differently from the actual computer.

### Quick Access Panel

- Wi-Fi
- Bluetooth
- Do not Disturb
- Mute mode
- Airplane mode
- Alarm
- Sleep mode
- ❖ Tap an Icon once to enable or disable.
- ❖ Press and hold an Icon to access the settings.



### Brightness

- Move the slider bar left or right to adjust screen brightness.

Shortcut to System Settings 

Navigation Bar

### To open the Full Quick Access Panel

- From the **Lock Screen**, swipe down from top of the touch screen once.
- From the **Home Screen**, swipe down with two fingers from top of the touch screen.
- If the Notification Panel is open swipe down from the **Quick Settings bar**.
- For additional shortcut Icon's swipe screen from right to left.
- Tap **Navigation Bar** to exit.

## Application Drawer

The application drawer is a menu containing all the applications installed on the device including System Settings. This is different from the Home Screen, as it contains every installed app and cannot be customized.

**Note:** The images below may appear different from the actual computer.

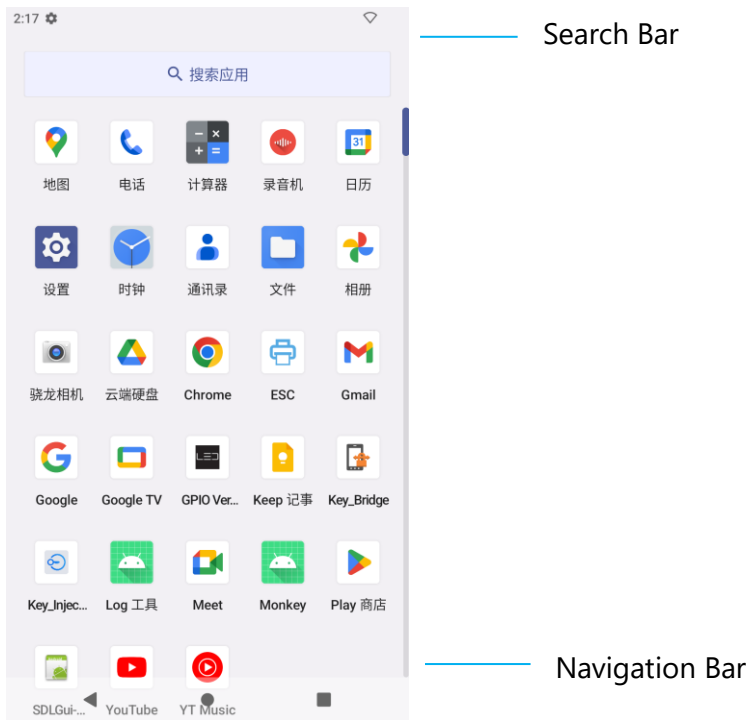

### To open the Application Drawer (Manager)

- Swipe up the **Navigation Bar** from the **Home Screen**.
- To open an application, tap once.
- To exit from the **Application Drawer**, tap the Navigation Bar or swipe down.



## Customize and add a shortcut to the Home Screen

**Note:** The images below may appear different from the actual computer.

- From the **Application drawer**, press and hold an app or (Icon) then drag the Icon to move the app to the **Home Screen**.
- Drag the Icon into new location and release.

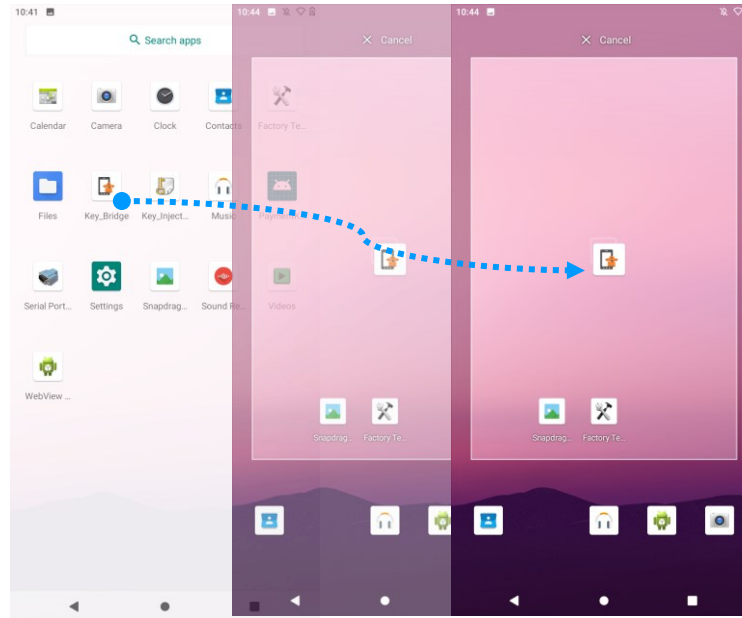

- To cancel, drag the icon to "**X Cancel**".
- To remove a shortcut Icon from home screen, press and hold the Icon then drag the Icon to "**X Remove**".
- To uninstall an app, press and hold then drag the icon to "**Uninstall**".

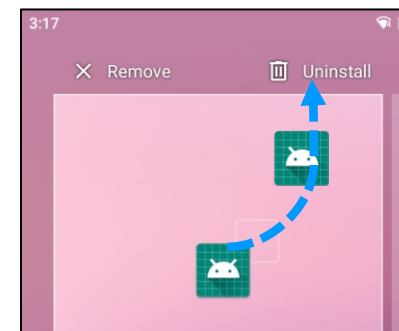
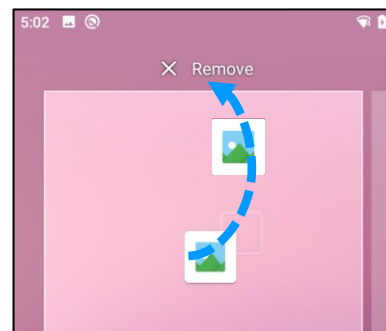
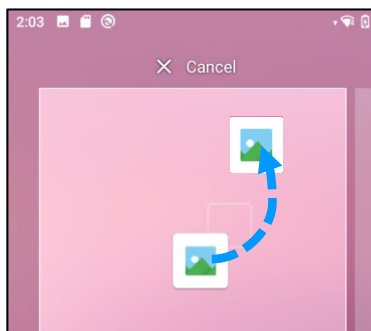

# Section 3: System Settings





## Network & Internet

The Network & Internet application allows you to access Wi-Fi, Airplane Mode, Mobile plan, Hotspot, Tethering and Advanced settings of Data Saver, VPN and DNS.

To set up Network and Internet, enter to System Settings  → Network & Internet

### Wi-Fi

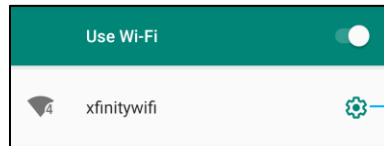

- Tap **Wi-Fi**.
- Tap **Use Wi-Fi** to enable .
- From the list, select a wireless network.
- When prompted enter the network password.
- Tap **Connect**.

For additional Network detail information's (IP address, Security, Frequency and Advanced), tap  setting of the network (e.g., xfinitywifi).





Wireless network setting



### Joining Wi-Fi using QR code

- From the list of saved Wi-Fi scroll down and tap  Add network .
- Tap  (QR code) icon to the right of Add network.
- Position the viewfinder over the QR code on another device.

#### Sharing Wi-Fi using QR code

- Tap  setting of the connected device.
- Tap  (Share) icon.

#### Disconnecting a connected Wireless Network



- Tap  setting of the connected device.
- Tap  (FORGET) icon to disconnect.

## Mobile Network

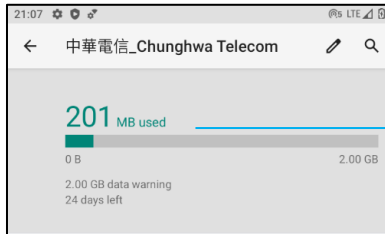

- Tap **Mobile network**.
- Internet service provider and data usage is shown on the top.



Total Data Usage

- Tap **Mobile data** to enable mobile data .
- Tap **Roaming** to enable roaming .
- Tap **Preferred Network Type** to choose preferred network available, e.g., LTE(Recommended)/3G.

App Data Usage

- Tap  to set the period for mobile data usage calculation.
- Tap  to set data warning & limit.

Automatically Select Network / APN

- Tap **Advanced**.
- Tap toggle switch  to enable Automatic network select.
- Tap **Access Point Names** to select APN from the available APNs list.

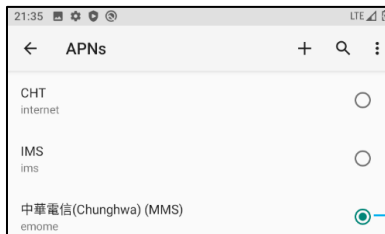

Tap to select the APN to be used

## Airplane Mode

This will disable all of the wireless transmission functions. Including cellular, Wi-Fi, and Bluetooth.



- To enable , tap **Airplane mode**.

## Hotspot & Tethering

### Wi-Fi hotspot

This feature is for sharing Internet network connection with another device using Wi-Fi.

**Note:** The mobile POS must be connected to Wi-Fi or cellular network (cellular SKUs). See *Network & Internet connection on this user manual*.

- Tap **Hotspot and tethering**.
- Tap **Wi-Fi hotspot**.
- Tap toggle switch to ON .
- Tap  QR code.
- The QR code is for another device to scan the password for easy connect.
- To enter manually the password, tap **Hotspot password**.

### USB tethering

This feature is for sharing Internet connection to another device using a USB cable.

**Note:** The USB cable must be connected first from mobile POS to another device or PC. See *Connected device → USB on this user manual*.

- Tap **Hotspot and tethering**.
- Tap **USB tethering**, to enable .

### Bluetooth Tethering



This feature is for sharing internet network connection to another device using Bluetooth.

**Note:** The Bluetooth must be paired first from mobile POS to another device or PC. See *Connected devices → Bluetooth on this user manual*.

- Tap **Hotspot and tethering**.
- To enable , tap **Bluetooth tethering**.

### Ethernet

**Note:** To connect the mobile POS to Ethernet, it will need an Elo I/O hub (E863687). When available, the mobile POS will automatically prioritize the ethernet connection. If does not, please follow the steps below:

- Place the mobile POS into the Elo hub.
- Set Wi-Fi to disable.
  - ❖ Go to Wi-Fi settings, tap **Use Wi-Fi** to disable .
- Tap **Ethernet**.
- Tap toggle switch to enable .



## Connected Devices

The Connected devices application allows you to pair Bluetooth devices, NFC, and USB (Tethering File transfer MDI and PTP)

To setup, enter to **System Settings**  → **Connected devices**

### Bluetooth

**Note:** Elo mobile POS supports Bluetooth 5.1 Classic/LE and Beacon; to remain PCI-PTS compliant, only devices supporting Bluetooth Security Mode -4 (Authenticated Link / Secure Connection) can be paired and connected to the Elo mobile POS.

**Note:** Make sure the BT device is on discoverable.

- Tap **Connection preferences**.
- Tap **Bluetooth**.
- Tap toggle switch to ON .
- Tap + **Pair new device**.
- From Available devices screen, tap a device to pair.
- When a pairing request message appears.
  - ❖ Verify the pairing number is the same.
  - ❖ If the pairing requests a PIN, enter the PIN.
- Tap **PAIR**, to connect.
- When the Bluetooth device is successfully connected to mobile POS, the connection will show as Active or Connected.

### Unpair a paired Bluetooth Device

- Navigate back to 'Connected devices' screen, from **AVAILABLE MEDIA DEVICES** or **PREVIOUSLY CONNECTED DEVICES**.
- Tap  settings of the connected device.
- In the settings menu, it is possible to **DISCONNECT**, **FORGET** (to unpair the device) and to enable and disable Phone calls, Media audio and Contact sharing.

### Cast

This allows to mirror Elo mobile POS screen on a wireless display device (e.g., Smart TV).

**Note:** Make sure the wireless display capable device and mobile POS are on the same wireless network. See Network & Internet connection section of this user manual.

- Tap **Connection preferences**.
- Tap Cast.

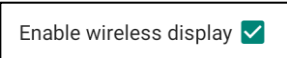
- Tap  3-dots menu.
- Tap **Enable wireless display**  to begin scanning for compatible displays.
- From the list, tap a wireless display (e.g., TV) from the Wireless Display device (TV), if prompted tap **Allow**.

#### Disconnect and forget a connected wireless display

- To stop the device from casting, tap the connected wireless display (e.g., TV).
- Tap **DISCONNECT**.



#### To forget a device

- Tap  setting of connected wireless display.
- From wireless display options screen, tap **FORGET**.

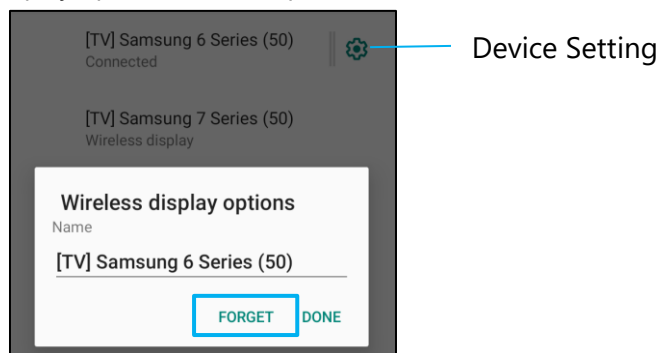

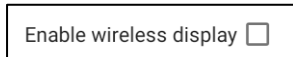

#### To stop scanning available wireless display to cast

- Tap  3-dots menu.
- Tap **Enable wireless display** to be unchecked



## Printing

**Note:** Make sure mobile POS and printer are connected to the same network.

- Tap **Connection preferences**.
- Tap **Printing**.
- Tap **Default Print Service**.
- Tap toggle switch to ON .
- Tap  3-dots menu.
- Tap **Add printer**.

### To add a printer using Wi-Fi printer:

- Tap **Wi-Fi direct printing** to enable .
- If prompted, tap '**ALLOW ONLY WHILE USING THE APP**' to allow the device.
- Tap **Wi-Fi Direct printers** to start searching for a Wi-Fi printer to add.
- Tap the printer's name to connect.

### To add a printer entering IP address:

- Tap **Add printer by IP address**.
- Enter the printer's IP address.

## USB

For data transfer and network sharing using a USB connection.

**Note:** To activate the USB settings, connect the USB cable from mobile POS to another device or PC. Once the mobile POS detects the device, it will become available in the USB preference settings.

- Tap USB.
- From USB Preferences under USE USB FOR choose and tap a feature to enable.

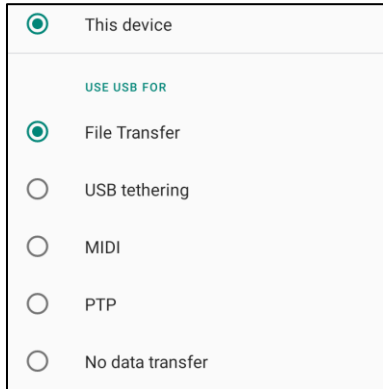

- **File transfer** – This will share mobile POS internal and SD shared storage.
- **USB tethering** – This will share internet network connection.
- **MIDI** - Musical Instrument Digital Interface.
- **PTP** - Picture Transfer Protocol.
- **No data transfer** – (Default Setting) No data will be transferred even if the USB cable is connected.





## Apps & Notification

App & Notification settings are to streamline app alerts by changing which apps send notifications and how the notifications alert you.

To manage App & Notification, enter to System Settings  → App & Notification  
**Setting notifications**

- In the Recently opened apps, tap **SEE ALL APPS** or **App info**.
- From App Info screen tap an App to set the notification (e.g., Android Keyboard).
- In the App property settings, you can also **DISABLE**, **ENABLE**, and **FORCE STOP** the app.

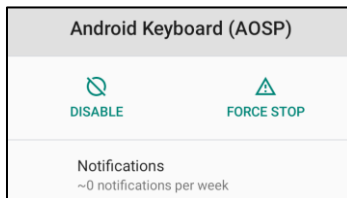

- To enable or disable notifications, tap **Notifications**. Then select **Show notifications**.

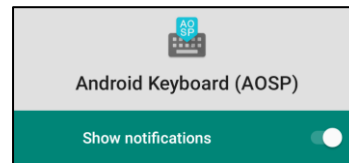
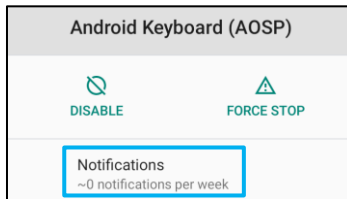

- To add a dot for unread notifications, tap **Advanced** then tap **Allow notification dot**.

### Resetting App Preferences

This will not lose any app data.

- Tap  3-dots menu from App Info screen.
- Tap **Reset app preferences** then tap **RESET APP**.

### Setting Permission manager to an application

- To manage a preference's permissions to an app (e.g., **Android Keyboard**), tap **Permissions**.
- To allow a permission to an application, tap an app from **DENIED** menu.
- To deny a permission to an application, tap an app from **ALLOWED** menu.

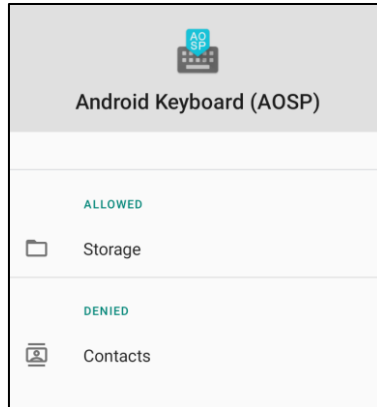

### Setting notifications in the lock screen

- To set up notification in the lock screen from Apps and notification screen, tap **Notifications**.
- Tap **Notification on lock screen**. Then follow on-screen instruction on how notifications appear in the lock screen.

### For additional settings

- Tap **Advanced**.
- Tap a feature to enable or disable.

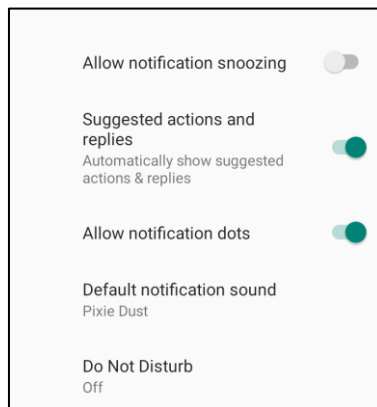

## Setting Permission manager on apps using storage, and location

- To give permission to an app, tap **Permission manager** from Apps and **notifications screen**.
- In the menu of permission manager, tap an app to manage that app's permissions (e.g., Camera).
- From the camera properties, choose an app to manage.
- To allow a permission to an application, tap an app from **DENIED** menu.
- To deny a permission to an application, tap an app from **ALLOWED** menu.

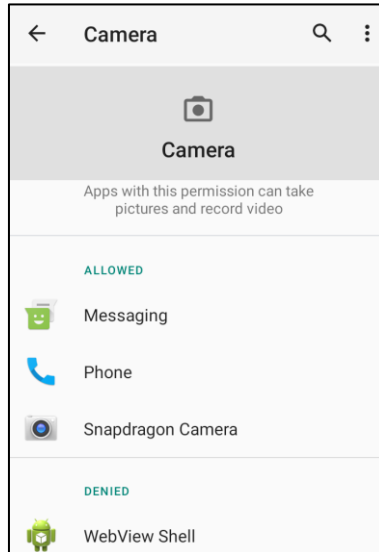

## Setting Emergency alerts

- Tap **Advanced** from the Apps and notifications screen.
- Tap **Emergency alerts**.
- From the menu of alerts, tap a feature to enable or disable.

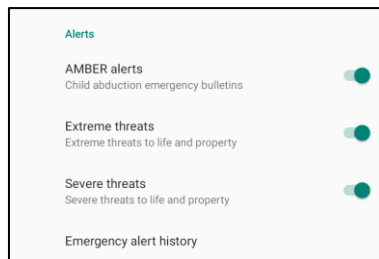

- For Alert reminder settings, tap **Alert reminder sound**.





The battery application monitors the battery's status, performance, and charging state.

**To modify Battery settings, enter to System Settings  → Battery**

### **Battery Saver**

The battery saver turns off, or restricts, background activity, some visual effects, and other high-power features to extend battery life.

**Note:** The Battery Saver will suspend these features when the device is charging.

- Tap **Battery Saver**.
- To manually enable or disable Battery Saver, tap **TURN ON NOW or TURN OFF NOW**.
- In the ON mode, the screen theme display will turn dark, and the battery status icon will display this icon .
- To automatically enable Battery Saver in a certain power percentage threshold, tap **Set a schedule**.
- Tap **Based on percentage to** set a power percentage when the Battery Saver feature will enable.
- From the slider bar move the slider right or left to choose the power percentage from 5% to 75%. The default is 5%.
- To do nothing, tap **No Schedule**.
- Enabling  "Turn off when full charged", the Battery Saver turns off when battery is at 90%.

### **Battery Manager**

When the Battery Manager detects that apps are draining the battery, you will have the option to restrict the application. Restricted apps may not work properly, and notifications may be delayed.

- Tap **Battery Manager**.
- Tap **Use Battery Manager** to enable.

### **Battery Percentage**

This feature will show battery percentage in the status bar.



- To enable and disable, tap **Battery percentage**.

## Display

The Display application manages the screen's display settings.

To modify Display settings, enter to System Settings  → Display

### Auto Idle Mode

- Tap **Auto idle mode** to enable  or disable .

### Brightness Level

- Tap **Brightness level**.
- Move the slider bar right or left to adjust the screen's brightness.



### Nigh Light Feature

This feature will tint the screen to amber. This makes easier to look at the screen or read in dim light.

- Tap **Nigh Light**.
- Tap **TURN ON NOW**.
- To adjust intensity, move the slider bar right or left.

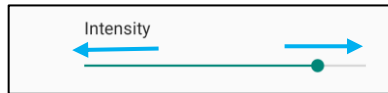

- To disable, tap **TURN OFF NOW**.

### Customizing a Time Schedule



- Tap **Schedule**.
- Select **Turn on at custom time**.
  - ❖ Tap **Start time** to set the time (for example at 10:00PM).
    - Tap **OK** to execute.
  - ❖ Tap **Enter time** to set the time (for example at 6:00AM),
    - Tap **OK** to execute.
- To disable the time schedule

- ❖ Tap **Schedule**.

- ❖ Tap **None**.

### **Adaptive Brightness**

This feature will automatically adjust the screen brightness to your environment.

- Tap **Adaptive Brightness**.
- Tap **Adaptive Brightness** to enable  or disable .

### **Wallpaper**

- Tap **Wallpaper**.
- Select a wallpaper from the following options.
  - ❖ Live Wallpapers
  - ❖ Snapdragon Gallery → Download – Picture – Screenshot
- Select an image or picture you want as a wallpaper from the folders.
- Tap SET WALLPAPER.



## Advanced

### Dark theme

- To switch screen theme on dark (black color) or light (white color), tap **Dark**.

### Screen timeout

- Tap Screen timeout.
- Select the time limit from the following option.

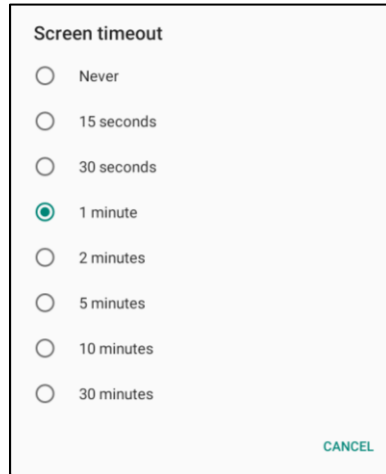

The screenshot shows a settings dialog titled "Screen timeout". It contains a list of radio button options: "Never", "15 seconds", "30 seconds", "1 minute", "2 minutes", "5 minutes", "10 minutes", and "30 minutes". The "1 minute" option is selected, indicated by a green dot. A "CANCEL" button is located at the bottom right of the dialog.

- Tap to save.

### Auto-rotation screen

- Tap Auto-rotation screen to enable or disable.

### Font size

- Tap Font size.
- Move the slider bar left or right to adjust the text size.

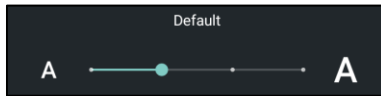

### Display size

- Tap Display size.
- Move the slider bar to left or right to adjust the screen size.

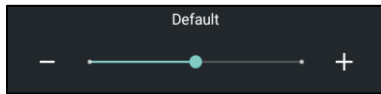

### Screen saver

- Tap Screen saver.
- Tap Current screen saver to make changes to the current settings.

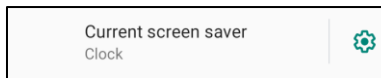

- Select a screen saver from Clock, Colors, Photo Frame, and Photo Table.
- For additional clock, Photo Frame, and Photo Table screen savers, tap  setting.

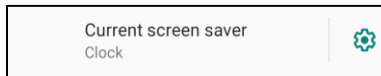

- To activate Screen saver, tap **START NOW**.





### Screen Orientation

- Tap Screen Orientation.
- Select the orientation from the following option.

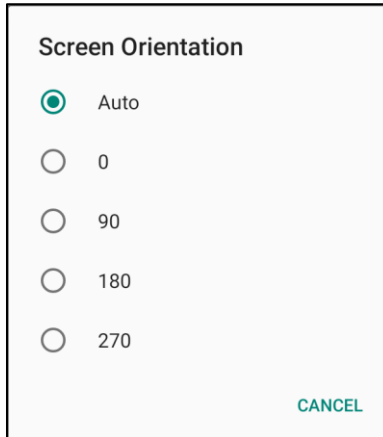

- Tap to save.

### Screen Density

- Tap Screen Density.
- Select the density from the following option.

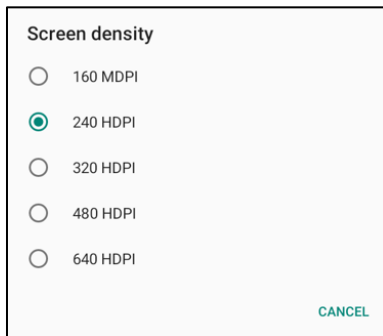

- Tap to save.

## Sound

The sound application is to manage audio, do not Disturb features.

**To modify settings, enter to System Settings  → Sound Volumes**

- To decrease or increase the following sound volume, drag slider left or right.

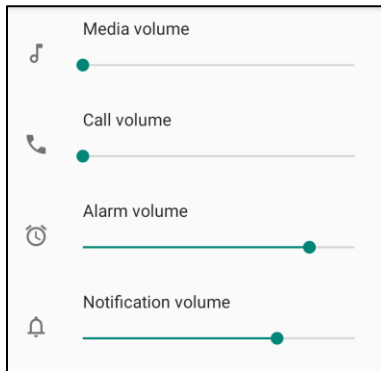

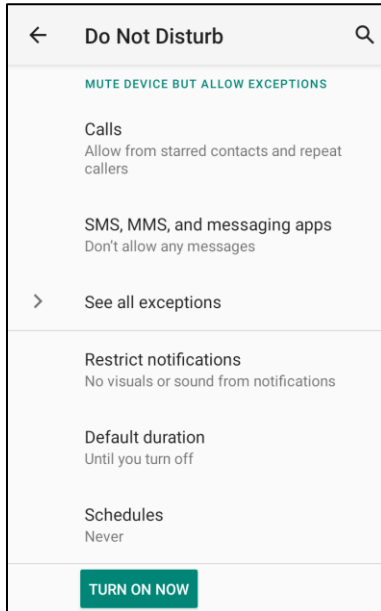

## Do not Disturb

- Tap **Do not Disturb**.
- Tap **TURN ON NOW**, to enable Do not Disturb,
  - ❖ To manage settings, tap a feature you wish to manage and follow on-screen instructions to complete the set up.



- To disable, tap **TURN OFF NOW**.

## Prevent Ringing

- Tap **Shortcut to prevent ringing**.
- Tap toggle switch to  enable.
  - ❖ To disable , tap toggle switch.

## Default Notification Sound

- Tap **Default notification sound**.
- Select a sound from the list (e.g., Pixie Dust) and tap **OK** to save.

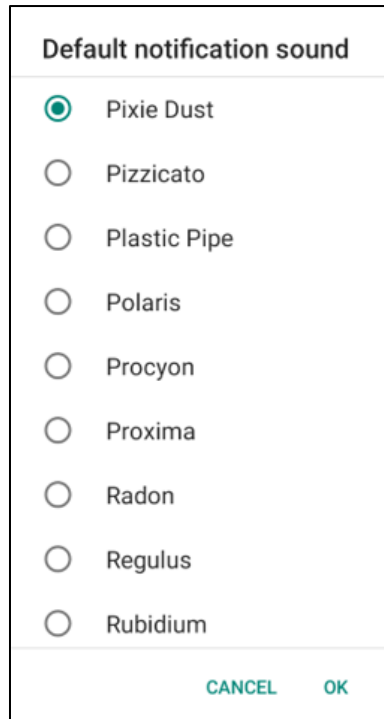

## Default Alarm Sound

- Tap **Default Alarm sound**.
- Select an alarm sound from the list (e.g., Cesium) and tap **OK** to save.

Default alarm sound

Cesium

Cesium

Fermium

Hassium

Helium

Krypton

Neon

Neptunium



Nobelium

CANCEL OK

## Screen Locking Sound

- To enable  or disable , tap Screen locking Sounds.

### Advanced

- To enable  or disable  on the following features below, tap a feature.

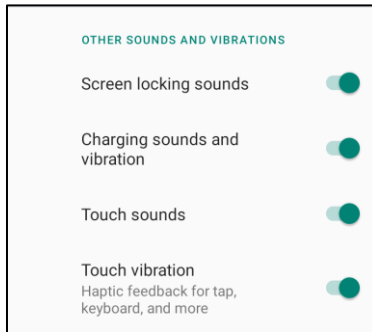



## Storage

### To manage Storage, enter to System Settings → Storage Internal Shared Storage

To check the status of internal memory storage, tap Internal Shared storage.

#### Storage Manager

This feature is to help free up storage space, storage manager removes backed up photos and video from the device.

- To enable  or disable , tap Storage manager.
- To make changes to set days on removing photos and videos, tap Remove photos & Videos.
- Select from the options below.

Over 30 days old  
Over 60 days old  
Over 90 days old

- Tap Recent App to exit.

#### SD card

- To manage SD card, tap SD card.
- To safely eject SD card, tap  eject.
- To remount the SD card, tap SD card.
- Tap MOUNT.

## Elo Settings

The Elo settings allows you to access the following features.

To access, enter to **System Settings**  → **Elo Settings**

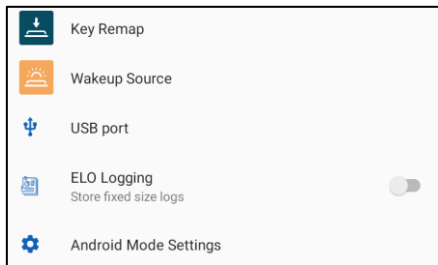

- This will allow you to program the left and right function buttons.
- This will allow you to program the left, right function buttons and Touch Screen to wake the device.
- Reserved for debugging purpose.
- This will allow you to enable GMS and ASOP mode.

## Wakeup Source

The Wakeup Source applications allows you to program the “Left, Right programmable buttons and Touch Screen” to wake up the device from sleep or idle mode.

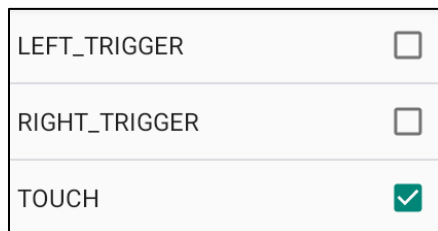

Tap to Enable (Checked) or Disable (Unchecked).  
Double quick tap for wake on touch.





The Privacy application is to give you control over what permissions of applications can have.

**To manage permission, enter to System Settings  → Privacy**



### **Permission Manger**

This is to grant permission of an App that uses storage, and location.

- To manage permissions to an app, tap **Permission manager**.
- From the menu of permission manager, tap an app you wish to manage (e.g., Camera).
- From the camera property shows what applications has camera permissions.
- To allow a permission to an application, tap an app from **DENIED** menu.
- To deny a permission to an application, tap an app from **ALLOWED** menu.



### **Show Passwords**

This will display character briefly as you type a password.

- To enable  and disable  , tap **Show passwords**.

### **Lock Screen**

This will show all notification content in the lock screen.

- To enable  and disable  , tap **Lock screen**.

## Location

To modify Location settings, enter to System Settings  → Location

- Tap Location.
- To enable or disable, tap Use location

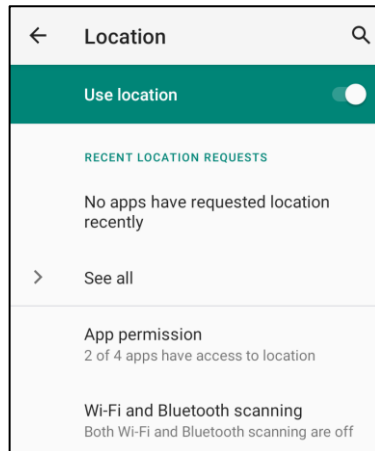

- For apps have requested location recently, tap **See all**.
- To update permission, tap **App permission**.
- To scan for Wi-Fi networks and Bluetooth, tap **Wi-Fi and Bluetooth scanning**,

**Note:** This feature allows app and services to scan for Wi-fi networks and Bluetooth anytime. This can be used to improve location-based features and services.



To change Security settings, enter to System Settings  → Security  
**Screen Lock**

- Tap **Screen lock**.
- From the menu select a security you wish to set. The default security is Swipe.

### **Swipe Security**

- Tap **Swipe**.

### **Pattern Security**

- Tap **Pattern**.
- Draw a Pattern for security (see image for an example) and tap **NEXT**.

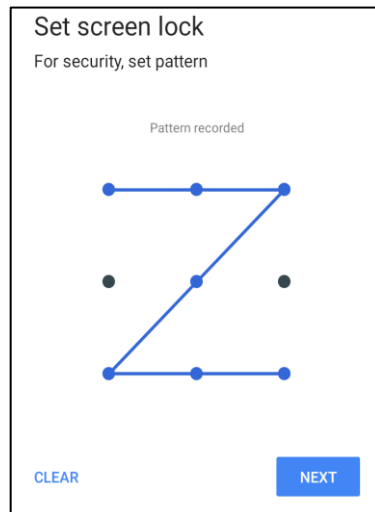

- Draw the same pattern again and tap **CONFIRM**.
- Follow on-screen instruction and tap **DONE**.

## Pin Security

- Tap **PIN**.
- Tap **YES**.
- Enter a PIN number must be at least 4 digits minimum and tap **NEXT**.

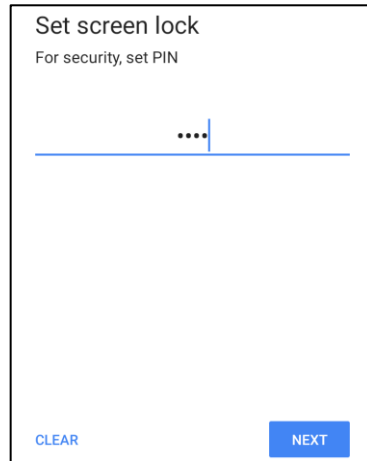

Set screen lock  
For security, set PIN

....|

CLEAR NEXT

- Re-enter PIN numbers and tap **CONFIRM**.
- Follow on-screen instruction and tap **DONE**.

## Password Security

- Tap **Password**.
- Tap **YES**.
- Enter a password, must be at least 4 characters minimum and tap **NEXT**.

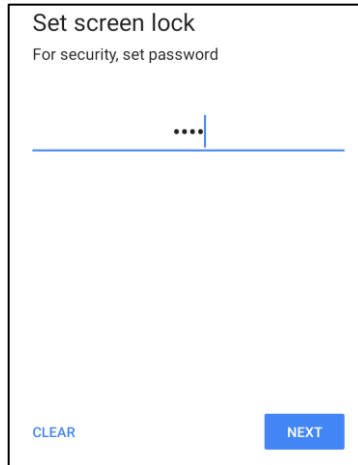

Set screen lock  
For security, set password

....

CLEAR NEXT

- Re-enter password and tap **CONFIRM**.
- Follow on-screen instruction and tap **DONE**.

## Remove Screen Lock

- To remove screen lock, tap **Screen lock**.
- If prompted enter the Password (only applicable for PIN, PATTERN and PASSWORD security).
- Tap **None** to remove screen lock.
- Tap **YES**.
- Tap **REMOVE** to confirm.



## Accounts



**To add an account, enter to System Settings  → Accounts**

- To set up an account, tap Account.
- Tap + **Add account**.
- Enter an email account.
- Enter an Account type you want to add (PERSONAL - POP3 or PERSONAL – IAMP).
- Follow the on-screen instructions to complete the setup.

# Accessibility

The Accessibility is a large on-screen menu to control Elo mobile POS device. You can control display, audio & on-screen text and more.

## To modify settings, enter to System Settings → Accessibility

- From the menu, select a feature to change the setting.
- To enable  or disable , tap the feature.
- To adjust slide bar, drag slider right or left.



- For other settings, tap the feature and follow the on-screen instruction to complete the setup.

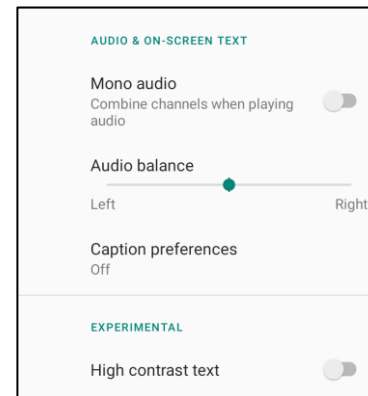
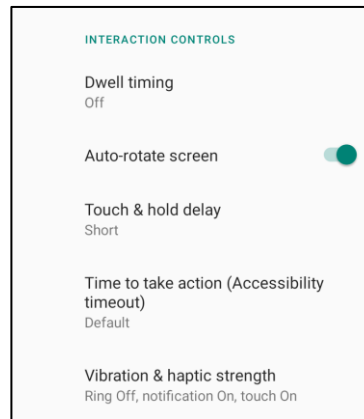
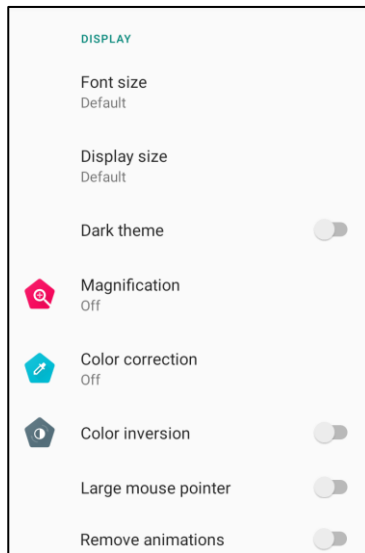



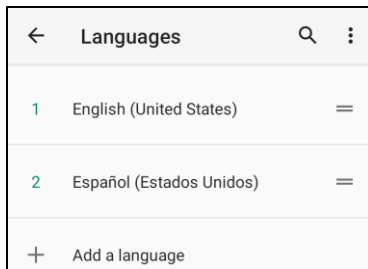

**To modify settings, enter to System Settings  → System Languages & Input**

- To change language, tap **Languages & input**.
- Tap **Language**.
- Tap + Add a language, then choose from the list of languages to add (e.g., Espanol).



- After choosing a language, tap  3-dots menu then tap Remove.
- To change a language e.g., from English to Espanol, tap English then tap .



- Tap OK to remove selected language.

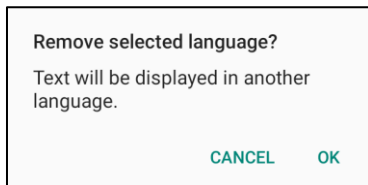





## Gestures

- Tap **Gestures**.

### For camera gesture

- Tap **Jump to camera**.
- Tap Jump to camera to enable  or disable .
- ❖ When set to enable, pressing power button twice will activate, the digital camera.

### For notification volume gesture

- Tap **Prevent ringing**
- Tap toggle switch to ON or OFF.



- When set to Mute mode and notification volume is active, pressing power + volume up buttons together, the notification volume will be muted.
- The mute icon will also show into status bar.



## Date & Time

**Note:** The recommended setting for “**Date and Time**” is to use, “**USE network provided time**”.

And for **Time zone** when is set to “**USE network provided zone**”, you need a sim card to work.

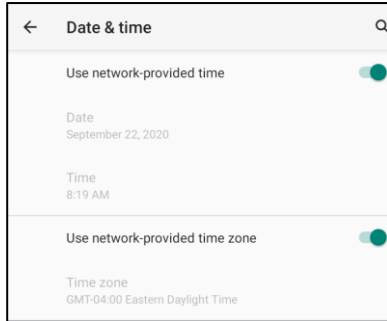

### For manual settings

- To set time and date, tap **Date & Time**.
- Tap **Use network-provided time** to disable.
- Tap **Date** then enter date.
- Tap **Time** then enter time.

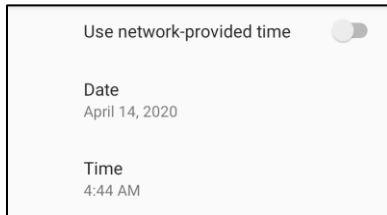

- To set time zone, tap **Use network -provided time** and select your time zone.

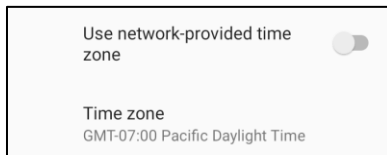

- To set to 12 hours format, tap **Use locale default**.

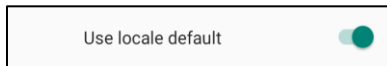

- To set 24 formats, tap **Use 24-hours format**.

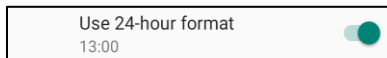

## Advanced

### Reset options

- To select a following option to reset, tap Reset options.
- From the list, select an item to reset then tap to execute and follow on-screen instruction.

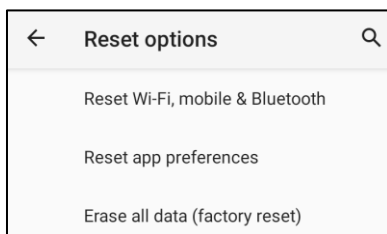

### Multiple users

- Tap Multiple users.
- Tap toggle switch to  ON.

#### To switch users

- Tap a user or name from the following option.

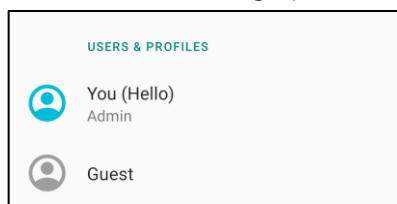

#### To add user

**Note:** only admin can add users.

- Tap + **Add user or profile**.
- To set up apps and contents for the user, tap **User**. Follow on-screen instructions to complete account set up.
- To set up restriction access to apps and content for the users, tap **Restricted profile**. Follow on-screen instructions to complete account set up.

#### To delete guest from the device

- Tap  3-dot menu from **Multiple Users** screen.
- Tap **Delete Guest** from this device.

### To rename Admin Profile info

- Tap  **admin**.
- Enter the name.
- Tap **OK** to save.



## About Device

For viewing specific information of mobile POS.

To view and modify settings, enter to System Settings  → About Device

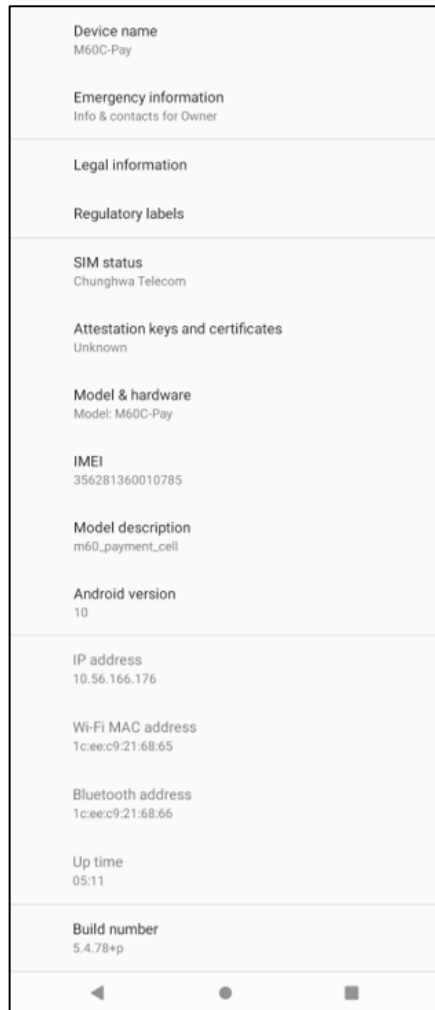

- Tap once to change the device name.
- Tap once to view add, and update emergency information.
- Tap once to view the information.
- Tap once to view SIM status.
- Tap once to view the information.
- Tap once to view Model, Hardware and Serial number information.
- Tap once to view IMEI information – IMEI and IMEI SV (Cellular SKUs).
- Tap once to view Elo mobile POS Model description.
- Tap once to view Android version, Security, system update, Baseband version, Kernel version and Build number
- Network/Wi-Fi/Bluetooth information.
- Android OS Version.

# Section 4: Operational

## About Camera App

### Camera Features

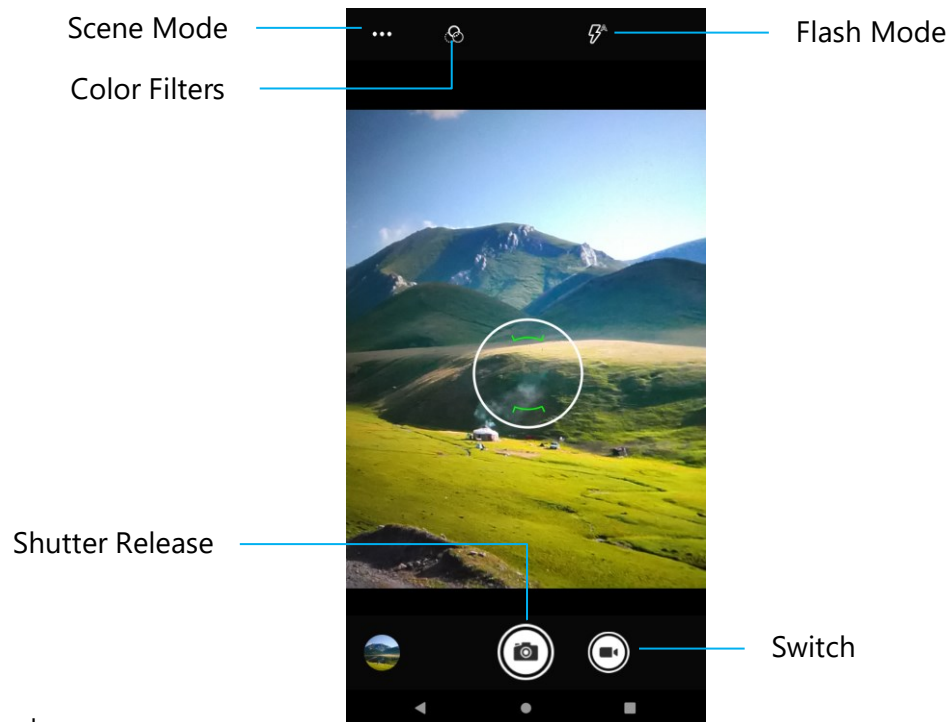

**Switch** – A switch for Video Capture mode.

**Scene Mode** – For selecting the best exposure settings to fit the type of scene being shot. That is, in addition to the amount of light in the scene.

Options include: Automatic, HDR.

**Flash Mode** – For flash control. Options include Auto, On, Off.

**Color Filter** – For photo effect. Options include Mono – Sepia – Negative – Solarize – Posturize – Aqua.

**Shutter Release** – For taking picture.

## Advanced Settings

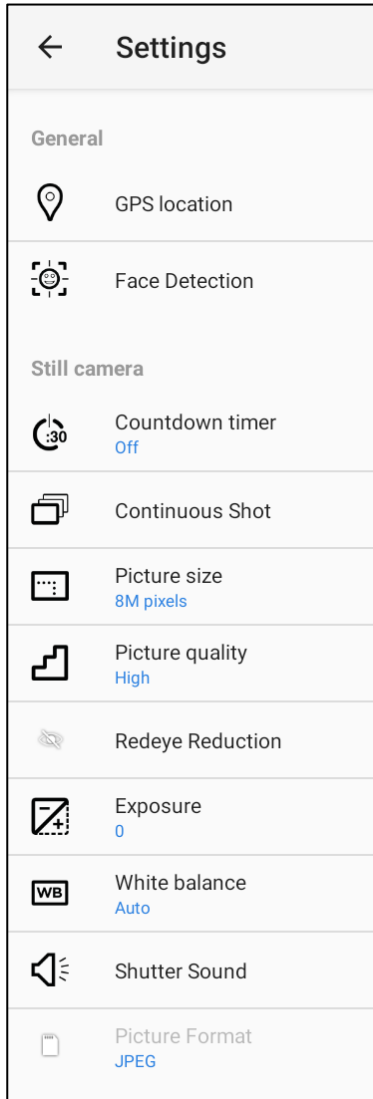

- For showing location information in an image to show the photographer where the camera was when the photo was taken.
- For detecting faces in the images and recognize them to automatically adjust focus and exposure.
- Is a timer that gives a delay between pressing the shutter release. It is most used to let photographers to take a photo themselves (often with family), hands free.
- For taking multiple photographs to be taken within a short timeframe and in rapid succession.
- For changing picture resolution.
- For enhancing photos and images.
- For reducing reddyeye when taking a picture using flash.
- Exposure is the amount of light which reaches your camera sensor. It is a crucial part of how bright or dark your pictures appear.
- For eliminating the discoloration in an image due to certain colors in the scene having more intensity and/or a higher or lower "temperature".
- Play a tone when taking a picture.
- For changing the file format of picture.

## Video Features

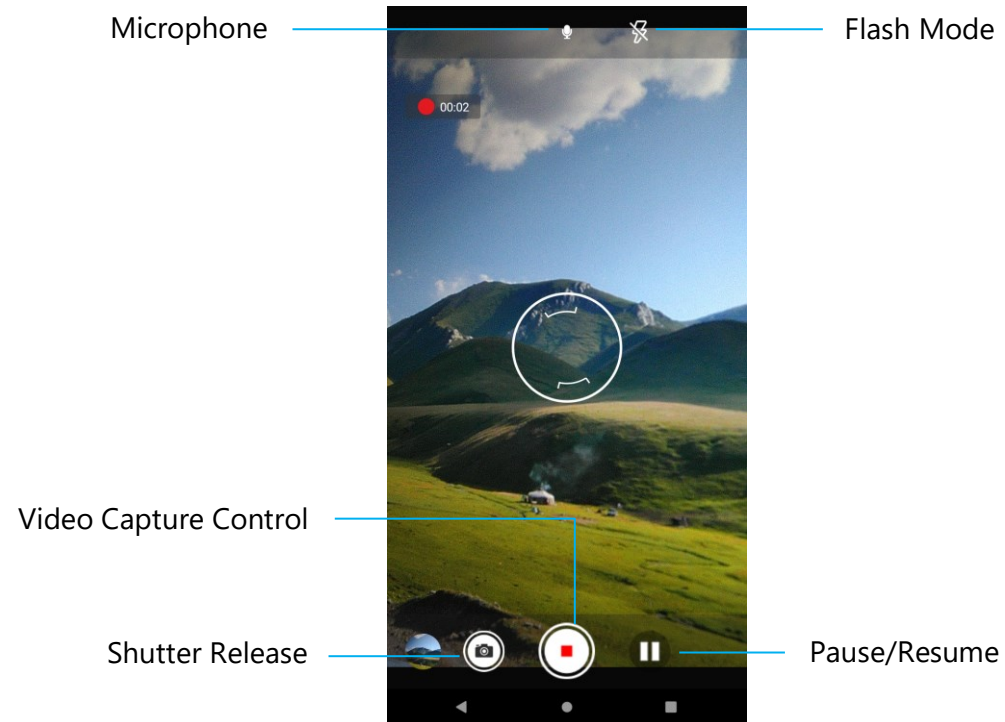

**Shutter Release** – Taking a picture while video recording is in progress.

**Video Capture Control** – Start/Stop capturing video.











**Pause/Resume** – Pause/Resume capturing video.

**Flash Mode** – For flash control. Options include Auto, On, Off.

**Microphone** – For capturing sound on video.



## Advanced Settings

Video camera	
	Video quality HD 1080p
	Video duration 10 minutes
	Noise Reduction Off
	Video Encoder H264
	Audio Encoder AAC
	Video Rotation 0
	Time lapse Off
	Video High FrameRate Off
System	
	Restore defaults
	Version Info 2.0.002



- For changing video resolution.
- Is an auto timer to stop video recording without pressing video capture Icon.
- Is a feature reducing noise and causes the image to lose its sharpness. This mode is only recommended to use while you are taking pictures in artificial light like indoors.
- For changing video encoder for the video file.
- For changing audio encoder for the video file.
- For changing rotation of the video.
- For changing interval when time lapse feature is enabled.
- HFR refers to higher frame rates than typical prior practice (e.g., 24 fps for standard movies).
- For restoring default settings.
- Shows camera application version information.

## Take a Picture and Record Video

- Tap  Snapdragon **camera app** to access the Digital camera.
- To change camera and video settings, see features.
- From the switch, located on bottom left side of the mobile POS select one from the following options.





For Panorama, tap  Panorama icon.

- ❖ To take panoramic pictures, tap  panorama shutter icon.
- ❖ Slowly move the device across to take a panoramic picture.
- ❖ When finished, tap  stop icon.





For Video recording, tap  Video icon.

- ❖ To record videos, tap  Capture icon.
- ❖ To mute and unmute sound while recording, tap microphone icon.
- ❖ When finished recording, tap  Stop icon













For camera, tap  Camera icon.



- ❖ To take pictures, tap  Shutter release icon.
- ❖ To enable and disable shutter sound, go to advanced settings. See camera features.
- ❖ To zoom an object or scene place two fingers on the screen together, spreads them apart to zoom in and pinch to zoom out.
- ❖ To auto focus an object or scene, tap touch screen.
- ❖ To play recorded video, tap  Play icon.

## About File Application





The File Manager app helps to manage, delete, print, shares and transfer files between the mobile storage and a computer. To access pictures, videos, screenshots, audios, downloads, and mobile internal / external storage, go to application drawer.

- Tap  File application from the application drawer.
- Tap  3 lines menu and choose one of the following options.
- Tap  Image icon for pictures and screenshots.
  - ❖ Tap  Camera folder for photos.
  - ❖ Tap  Screenshots folder for screenshot images.
  - ❖ Tap  Video for recorded videos.
  - ❖ Tap  Camera folder.
  - ❖ Tap  Audio for recorded audios.
  - ❖ Tap  for Downloaded items.
  - ❖ Tap  for mobile internal storage folders.
  - ❖ Tap  for mobile external storage folders.

### Delete Files

- To delete files from the folders above, press and hold an item or tap  3 dots menu to select all items in the folder.
- Tap  to delete.
- Tap OK to confirm.

## Copy and Move Files





- To copy or move files into new location press and hold an item from the folders above or tap  3 dots menu to select all items in the folder.
- Tap  3 dots menu again and choose "Copy to" or "Move to".
- Tap  3 lines menu and choose from the following options where you want to move or copy the item.
- To create a new folder, tap  3 dots menu.
- Rename the folder.
- Tap Copy or Move to confirm.
- Print File.

**Note:** To print you must set a printer. See Settings → Connected device → Print.

- To print files from the folders above, tap an item once.
- Tap  3 dots menu and tap Print.



## Share Files

**Note:** Make sure both devices Bluetooth are paired. See Connected devices → Bluetooth on this user manual.

- To share files from the folders above, press and hold an item.
- tap  share icon.
- To share via Bluetooth, tap  Bluetooth icon.
- To share via email, tap  email icon
- For more options hold an item from the folders above.
- Tap  3 dots menu and choose from the following options and follow on-screen instructions.

## Scanning QR code with Integrated Camera (Pictures need to be updated)

To test the functionality of the camera for reading QR code, open (Camera / Snapdragon app) from application drawer. The App will allow to enable the camera as imager, decode the barcode data, and display the barcode content.

- Open the camera application (Snapdragon).
- Take a photo of the following QR code below.
- Tap the photo gallery at lower left corner.
- Below the QR code picture, tap the QR icon .
- Tap the content of the QR code .
- After tapping the content ([www.elotouch.com](http://www.elotouch.com)), the website will open.

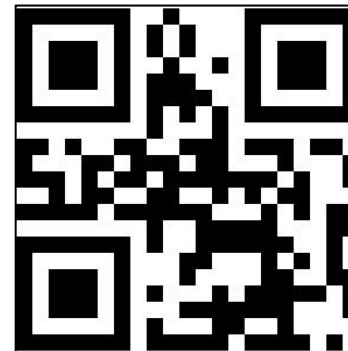
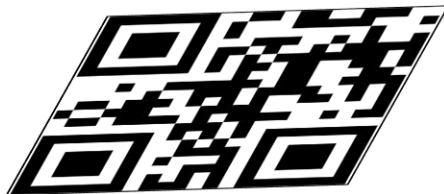
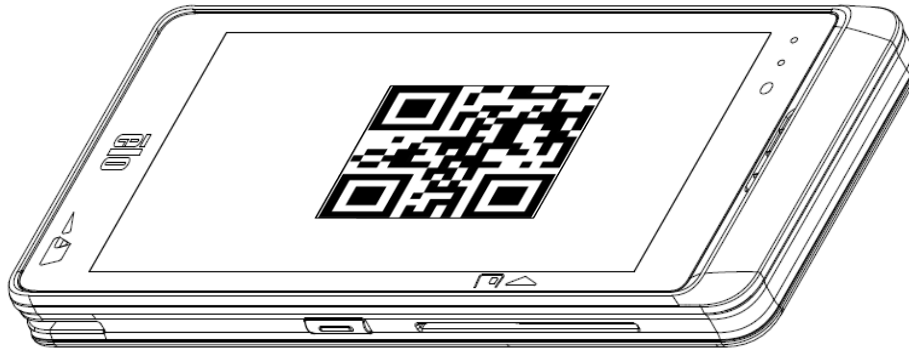

## NFC / EMV

### NFC/EMV Contactless Reader Spec

EMVCo L1 and L2 contactless certified:

- Visa PayWave.
- MasterCard PayPass.
- AMEX ExpressPay.
- Discover D-PAS.
- JCB Jspeedy.
- UnionPay QuickPass.
- From Available devices screen, tap a device to pair.

Compatible with:

- ISO14443-Type A & B (for EMV cards) read and write mode.
- ISO18092.
- MiFare.

### Reading NFC and EVM card

- To start reading NFC card, open the Elo demo payment app or depending which application is installed.
- Follow the on-screen instruction.
- When device is ready to read, place the NFC card at the location as show below.
- When the card is read by default a beep sound will turn ON.

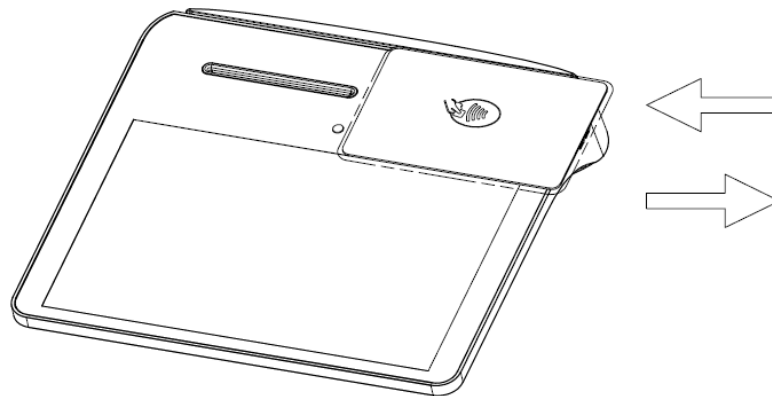

## SCR

### Smart Card Reader

- Compliant with ISO7816 standard.
- Compliant with PCI-PTS, EMVCo L1 and L2.
- Supported Card schemes.
  - ❖ Visa.
  - ❖ Mastercard.
  - ❖ American Express.
  - ❖ Discover.
  - ❖ JCB.
  - ❖ UnionPay.

### Reading SCR Card

- To start reading SCR, open the Elo demo Payment app or depending which application is installed.
- Follow the on-screen instructions.
- Insert the card at the location.

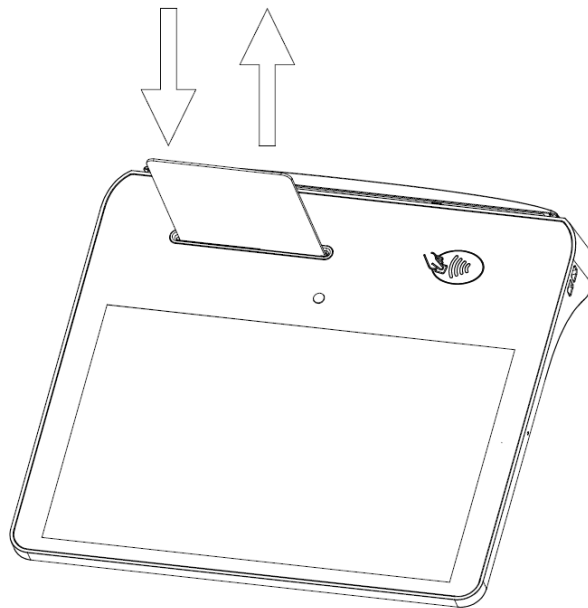

## MSR

Bidirectional MSR capable of reading up to three tracks of data on ISO 7810/7811.

### Reading MSR Card

- To start reading MSR, open the Elo demo Payment app or depending which application is installed.
- Follow the on-screen instructions.
- Swipe the card at the location.

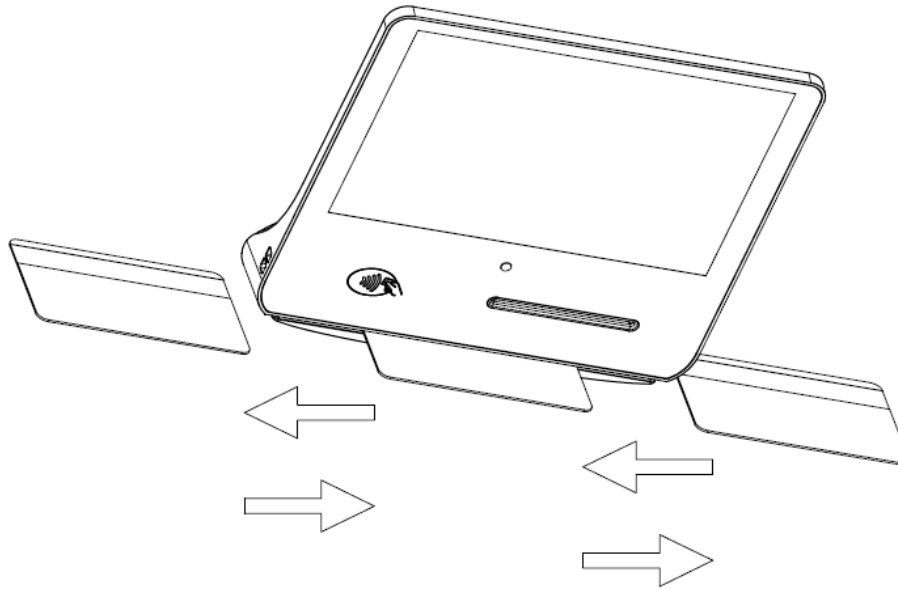



## About Elo Mobile Factory Full Reset

A full factory reset should only be performed if all other recovery methods have failed and all other troubleshooting options. Performing a full factory reset results in loss of data. This options will recover the original factory image state by erasing all data in the main storage on the Elo handheld computer.

**Note:** Performing a factory reset on **bootloader menu**, if you added a Google Account to Elo handheld Computer make sure you have your Google credential (Username and password) associated with the Elo handheld computer. If you don't have it you will not be able to use the device after reset. This is a security measure that prevents unauthorized user from using the device if they do a factory reset on bootloader menu.

### To Reset

- Enter to **System Settings**  → **System** → **Advanced** → **Reset Options**.
- Tap **Erase all data**.
- Under **Erase all data (factory reset)** or **Erase all data (factory reset to EloVidw® Mode)**, tap Erase all data .
- Under **Erase all data?**, tap Erase all data.
- When successfully done, the device will auto reboot.

# Section 5: Maintenance and Troubleshooting

## Elo Mobile POS Care and Handling

The following tips will help maintain optimal performance of your Elo mobile POS:

- To prepare for cleaning the touchscreen, power down the device (if possible), or ensure your on-screen software can tolerate false touches while you clean.
- Do not get liquids inside the unit. Do not spray the Elo product directly. Instead, use wet wipes, a sprayed cloth or a dampened cloth with the excess moisture squeezed off.
- Select only non-abrasive cleaning wipes or cloths to avoid scratching touchscreens.
- Avoid highly concentrated alcohol (> 70%), non-diluted bleach or ammonia solutions, as these may cause discoloration.
- Wipe the surfaces with the appropriate wipes or cloths and approved cleaning products and allow them to dry.
- For additional cleaning methods, recommended cleaning and disinfectant solutions, please visit <https://www.elotouch.com/support/technical-support/cleaning>

**Note:** The Elo I-Series Pay 7" POS terminal comes equipped with tamper evident labels. The terminal unit contains no user serviceable parts. Do not, under any circumstance, attempt to disassemble the terminal. Perform only those adjustments troubleshooting actions specified in this user guide. For all other services, contact your local Elo service provider. Service conducted by non-authorized representatives may void any warranty.

# Section 6: Elo Service and Support

## Elo Service and Support

### Technical Specifications

visit [www.elotouch.com/products](http://www.elotouch.com/products)  
for technical specifications for this device

### Support

visit [www.elotouch.com/support](http://www.elotouch.com/support) for technical support

Refer to last page for worldwide technical support phone numbers.

**Note:** Customers outside the United States are advised to contact their local representatives for assistance regarding service, return, or replacement of terminals.

## Returning a Terminal for Service

Elo recommends contacting technical support for troubleshooting before proceeding with returns. After it is determined a product repair is required, visit the Elo website to access the online RMA portal. All products must have an RMA number before being returned to Elo. The product Serial Number will be required to obtain an RMA.

Visit <https://myelo.elotouch.com/support/s/> and Navigate to the Product Returns and Repairs section or directly access the RMA Portal by visiting <http://portal.elotouch.com/>

**Note:** Before returning a Elo I-Series Pay 7" POS terminal to Elo, you must obtain an RMA number. The following procedure describes the RMA process for how to return one or more Elo I-Series Pay 7" terminals for repair or replacement.

1. **Get the product PN and SN from the printed labels on the back of each I-Series Pay 7" terminal to be returned.**
2. **Obtain the RMA number(s) by completing the following.**
3. **Describe the problem(s).**
4. **Provide the shipping address where the repaired or replacement unit to be returned.**
5. **Keep a record information and documentation related to the RMA.**

# Section 7: Regulatory Information

## Electrical Safety Information

Compliance is required with respect to the voltage, frequency, and current requirements if indicated on the manufacturer's label. Connection to a different power source than those specified herein will likely result in improper operation, damage to the equipment, or pose a fire hazard if the limitations are not followed.

There are no operator serviceable parts inside this equipment. There are hazardous voltages generated by this equipment which constitute a safety hazard. Service should be provided only by a qualified service technician.

Contact a qualified electrician or the manufacturer if there are questions about the installation prior to connecting the equipment to mains power.

## Emissions and Immunity Information

Notice to Users in the United States:

### FCC

§ 15.19 This device complies with part 15 of the FCC Rules. Operation is subject to the following two conditions: (1) This device may not cause harmful interference, and (2) this device must accept any interference received, including interference that may cause undesired operation of the device.

§ 15.21 Changes or modifications not expressly approved by the party responsible for compliance could void the user's authority to operate the equipment.

§ 15.105 This equipment has been tested and found to comply with the limits for a Class B digital device, pursuant to part 15 of the FCC Rules. These limits are designed to provide reasonable protection against harmful interference in a residential installation. This equipment generates, uses, and can radiate radio frequency energy and, if not installed and used in accordance with the instructions, may cause harmful interference to radio communications. However, there is no guarantee that interference will not occur in a particular installation. If this equipment does cause harmful interference to radio or television reception, which can be determined by turning the equipment off and on, the user is encouraged to try to correct the interference by one or more of the following measures:

- Reorient or relocate the receiving antenna.
- Increase the separation between the equipment and receiver.
- Connect the equipment into an outlet on a circuit different from that to which the receiver is connected.
- Consult the dealer or an experienced radio/TV technician for help.

This equipment should be installed and operated to ensure a minimum of 0 cm spacing to any person.

Notice to Users in Canada for IC compliance: This equipment complies with the Class B limits for radio noise emissions from digital apparatus as established by the Radio Interference Regulations of Industrial Canada.

### **RF Exposure Information**

This equipment complies with FCC radiation exposure limits set forth for an uncontrolled environment.

This equipment must be installed and operated in accordance with provided instructions and the antenna(s) used for this transmitter must be installed to provide a separation distance of at least 20 cm from all persons and must not be co-located or operating in conjunction with any other antenna or transmitter.

### **IC Radiation Exposure Statement**

This equipment complies with IC radiation exposure limits set forth for an uncontrolled environment. This equipment should be installed and operated with minimum distance 20cm between the radiator & your body.

This device for operation in the band 5150–5250 MHz is only for indoor use to reduce the potential for harmful interference to co-channel mobile satellite systems.

L'appareil est conforme aux limites d'exposition au rayonnement IC spécifiées pour les environnements non contrôlés. La distance entre le radiateur et le corps doit être d'au moins 20 cm lors de l'installation et du fonctionnement de l'appareil.

L'appareil fonctionne dans la bande 5150–5250 MHz et n'est utilisé qu'en intérieur pour réduire les interférences nuisibles aux systèmes mobiles par satellite à canal identique.

### **CAN ICES3 (B)/NMB3(B)**

This device contains license-exempt transmitter(s)/receiver(s) that comply with Innovation, Science and Economic Development Canada's license-exempt RSS(s). Operation is subject to the following two conditions:

1. This device may not cause interference.
2. This device must accept any interference, including interference that may cause undesired operation of the device.

L'émetteur/récepteur exempt de licence contenu dans le présent appareil est conforme aux CNR d'Innovation, Sciences et Développement économique Canada applicables aux appareils radio exempts de licence. L'exploitation est autorisée aux deux conditions suivantes:

1. L'appareil ne doit pas produire de brouillage;
2. L'appareil doit accepter tout brouillage radioélectrique subi, même si le brouillage est susceptible d'en compromettre le fonctionnement.

Notice to Users in the European Union: Use only the provided power cords and interconnecting cabling provided with the equipment. Substitution of provided cords and cabling may compromise electrical safety or CE Mark Certification for emissions or immunity as required by the following standards:

This Information Technology Equipment (ITE) is required to have a CE Mark on the Manufacturer's label which means that the equipment has been tested to the following Directives and Standards: This equipment has been tested to the requirements for the CE Mark as required by EMC Directive 2014/30/ EU as indicated in European Standard EN 55032 Class B and the Low Voltage Directive 2014/35/EU as indicated in European Standard EN 62368-1.

### General Information to all Users

This equipment generates, uses, and can radiate radio frequency energy. If not installed and used according to this manual the equipment may cause interference with radio and television communications. There is, however, no guarantee that interference will not occur in any particular installation due to site-specific factors.

1. In order to meet emission and immunity requirements, the user must observe the following:
  - i. Use only the provided I/O cables to connect this digital device with any computer.
  - ii. To ensure compliance, use only the provided manufacturer's approved line cord.
  - iii. The user is cautioned that changes or modifications to the equipment not expressly approved by the party responsible for compliance could void the user's authority to operate the equipment.
2. If this equipment appears to cause interference with radio or television reception, or any other device:
  - i. Verify as an emission source by turning the equipment off and on. If you determine that this equipment is causing the interference, try to correct the interference by using one or more of the following measures:
    - a. Move the digital device away from the affected receiver.
    - b. Reposition (turn) the digital device with respect to the affected receiver.
    - c. Reorient the affected receiver's antenna.
    - d. Plug the digital device into a different AC outlet so the digital device and the receiver are on different branch circuits.
    - e. Disconnect and remove any I/O cables that the digital device does not use. (Unterminated I/O cables are a potential source of high RF emission levels.)
    - f. Plug the digital device into only a grounded outlet receptacle. Do not use AC adapter plugs. (Removing or cutting the line cord ground may increase RF emission levels and may also present a lethal shock hazard to the user.)

If you need additional help, consult your dealer, manufacturer, or an experienced radio or television technician.

## Radio Equipment Directive

Elo hereby declares that the radio equipment type, Elo handheld Computer, is in compliance with Directive 2014/53/EU. The full text of the EU Declaration of Conformity is available at the following internet address: [www.elotouch.com](http://www.elotouch.com)

This device is designed and intended for indoor use only.

	AT	BE	BG	HR	CY	CZ	DK
	EE	FI	FR	DE	EL	HU	IE
	IT	LV	LT	LU	MT	NL	PL
	PT	RO	SK	SI	ES	SE	UK

This device is restricted to indoor use

Operation frequency and radio-frequency power are listed as below:

- WLAN 802.11 a/b/g/n/ac.
  - ❖ 2400~2483.5MHz < 17dBm EIRP.
  - ❖ 5150~5250MHz < 18dBm EIRP.
- BT 2400~2483.5MHz < 11dBm EIRP.

## ECC/DEC/ (04)08

The use of the frequency band 5150-5350 MHz is restricted to indoor operation because of the protection requirements of satellite services EC R&TTE Directive EU Directive 2014/53/EU of the European Parliament and of the Council of 16 April 2014 on the harmonization of the laws of the Member States relating to the making available on the market of radio equipment and repealing Directive 1999/5/EC Text with EEA relevance.



Identification mark and the relevant technical documentation is held by: Elo Touch Solutions, Inc. 670 N. McCarthy Boulevard Suite 100 Milpitas, CA 95035 USA

### USA FCC ID:

- TBD

### Canada IC ID:

- TBD

## Agency Certifications

The following certifications and marks have been issued or declared for this peripheral:

- UL, FCC (US) – Class B. (In progress/TBC)
- cUL, IC (Canada). (In progress/TBC)
- CB (International Safety). (In progress/TBC)
- CE (Europe) – Class B. (In progress/TBC)
- RCM (Australia). (In progress/TBC)



## Waste Electrical & Electronic Equipment Directive (WEEE)



This product should not be disposed of with household waste. It should be deposited at a facility that enables recovery and recycling. Elo has put in place recycling arrangements in certain parts of the world. For information on how you can access these arrangements, please visit [www.elotouch.com/e-waste-recycling-program/](http://www.elotouch.com/e-waste-recycling-program/).



**Replace the battery with same type only. Improper replacement of battery may cause in risk of burns, fire, and explosions. Dispose the battery according to local regulations. Risk of fire and burns if properly handled. Do not open and crush, heat above 60° C / 140° F or incinerate. If there is a serious swelling of the battery, do not continue using.**

## Electronic Regulatory Labels

To view e-labels, (1) Enter to System Settings  → (2) Tap "About Device" → (3) Tap "Regulatory labels".

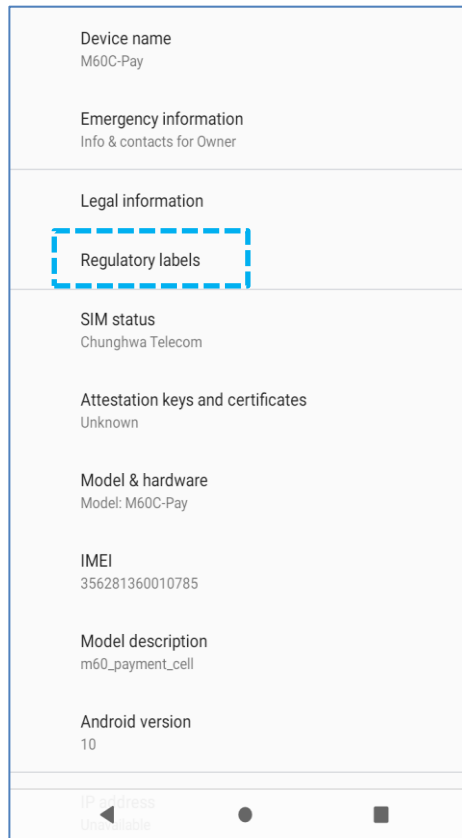

Product Name: Mobile POS  
 Model: EMC0600  
 Elo PN: E863128  
 Description: EMC0600-2UWA-0-AQ-POS-WIFI-GY-G

United States FCC ID: RBWEMC0600  
 This device complies with Part 15 of the FCC Rules.  
 Operation is subject to the following two conditions:  
 (1)This device may not cause harmful interference, and  
 (2)This device must accept any interference received,  
 including interference that may cause undesired operation.

Canada IC: 10757B-EMC0600  
 CAN ICES-003(B)/NMB-003(B)

Europe  

EU Importer: Elo Touch Solutions, Inc.  
 EU Contact : Elo Touch Solutions (Belgium) NV  
 Wingepark 5B / 301  
 3110 Rotselaar, Belgium  
 Brand Name: Elo

   670 N.McCarthy Blvd.  
 Suite 100  
 Milpitas, CA 95035  
 WWW.elotouch.com

Product Name: Mobile POS  
 Model name: EMC0600C  
 Elo PN: E862945  
 Description: EMC0600-2UWA-0-AQ-POS-CELL-US-GY-G

United States FCC ID: RBWEMC0600C  
 This device complies with Part 15 of the FCC Rules.  
 Operation is subject to the following two conditions:  
 (1)This device may not cause harmful interference, and  
 (2)This device must accept any interference received,  
 including interference that may cause undesired operation.

Canada IC: 10757B-EMC0600C  
 CAN ICES-003(B)/NMB-003(B)

Europe  

EU Importer: Elo Touch Solutions, Inc.  
 EU Contact : Elo Touch Solutions (Belgium) NV  
 Wingepark 5B / 301  
 3110 Rotselaar, Belgium  
 Brand Name: Elo

   670 N.McCarthy Blvd.  
 Suite 100  
 Milpitas, CA 95035  
 WWW.elotouch.com

Product Name: Mobile POS  
 Model name: EMC0600C  
 Elo PN: E993295  
 Description: EMC0600-2UWA-0-AQ-POS-CELL-EU-GY-G

United States FCC ID: RBWEMC0600C  
 This device complies with Part 15 of the FCC Rules.  
 Operation is subject to the following two conditions:  
 (1)This device may not cause harmful interference, and  
 (2)This device must accept any interference received,  
 including interference that may cause undesired operation.

Canada IC: 10757B-EMC0600C  
 CAN ICES-003(B)/NMB-003(B)

Europe  

EU Importer: Elo Touch Solutions, Inc.  
 EU Contact : Elo Touch Solutions (Belgium) NV  
 Wingepark 5B / 301  
 3110 Rotselaar, Belgium  
 Brand Name: Elo

   670 N.McCarthy Blvd.  
 Suite 100  
 Milpitas, CA 95035  
 WWW.elotouch.com

## Power Specifications

---

**Electrical Ratings**

---

Input	5VDC/3A, 9VDC/2A, 20VDC/2.25A(TBC)
-------	------------------------------------

---

**Operating Conditions**

---

Temperature	0°C - 50°C
-------------	------------

---

Humidity	10% to 90% (non-condensing)
----------	-----------------------------

---

Altitude	0 to +10,000 ft (3,048m)
----------	--------------------------

---

**Storage Conditions**

---

Temperature	-30°C - 60°C
-------------	--------------

---

Humidity	5% to 95% (non-condensing)
----------	----------------------------

---

Altitude	0 to +35,000 ft (10,668m)
----------	---------------------------

---

**Note:** This unit is intended to be supplied by an UL listed power source/device (Billion / Model: BQ018-090200CXX) suitable for use at Tma 50 degree C whose output meets LPS (or PS2) and is rated as Class II, 5Vd.c., 3A min., or contact Elo certified dealers for power adapters.

# Section 8: Warranty Information

For warranty information, go to <http://support.elotouch.com/warranty/>

Visit our website [www.elotouch.com](http://www.elotouch.com) for the latest information below:

- Product information.
- Specifications.
- Upcoming events.
- Press releases.
- Software drivers.

To find out more about our extensive range of Elo touch solutions, go to [www.elotouch.com](http://www.elotouch.com) or call the office nearest you.

Google, Android, Google Play and other marks are trademarks of Google LLC.

---

#### North America

Tel +1 408 597 8000  
Fax +1 408 597 8001  
[elosales.na@elotouch.com](mailto:elosales.na@elotouch.com)

#### Europe

Tel +32 (0)16 70 45 00  
Fax +32 (0)16 70 45 49  
[elosales@elotouch.com](mailto:elosales@elotouch.com)

#### Asia-Pacific

Tel +86 (21) 3329 1385  
Fax +86 (21) 3329 1400  
[www.elotouch.com.cn](http://www.elotouch.com.cn)

#### Latin America

Tel +52 55 2281 -6958  
[elosales.latam@elotouch.com](mailto:elosales.latam@elotouch.com)

