

FCC TEST REPORT

Under :

FCC 15 Subpart C, Paragraph 15.249: 2002

Prepared For :

Shenzhen Lian Yi Da Science Co., Ltd.

#2009A, Saige Building, Huaqiang Road North, Shenzhen China

FCC ID: RAWLYD208CA

EUT: Wireless Camera

Model: LYD208CA

October 15, 2003

Report Type: Original Report

Test Engineer: Peter Lin

Test Date: September 28, 2003

Review By: 

Apollo Liu / Manager

TABLE OF CONTENTS

1. General Information	3
1. 1 Notes.....	3
1. 2 Testing Laboratory.....	3
1. 3 Details of Applicant.....	3
1. 4 Application Details.....	3
1. 5 Test Item	3
1. 6 Test Standards.....	4
2. Technical Test.....	5
2. 1 Summary of Test Results	5
3. EUT Modifications	6
4. Conducted Power Line Test.....	7
4. 1 Test Equipment.....	7
4. 2 Test Procedure	7
4. 3 Test Setup	7
4. 4 Configuration of the EUT.....	8
4. 5 EUT Operating Condition.....	9
4. 6 Conducted Power Line Emission Limits	9
4. 7 Conducted Power Line Test Result.....	10
5. Radiated Emission Test	12
5. 1 Test Equipment.....	12
5. 2 Test Procedure	12
5. 3 Radiated Test Setup	12
5. 4 Configuration of the EUT.....	13
5. 5 EUT Operating Condition.....	13
5. 6 Radiated Emission Limit	13
5. 7 Radiated Emission Test Result.....	14
6. Band Edge	16
6. 1 Test Equipment.....	16
6. 2 Test Procedure	16
6. 3 Radiated Test Setup	16
6. 4 Configuration of The EUT.....	17
6. 5 EUT Operating Condition.....	17
6. 6 Band Edge FCC 15.249(d) Limit.....	17
6. 7 Band Edge Test Result.....	17
7. Photos of Testing.....	18
7. 1 EUT Test Photographs.....	18
7. 2 EUT Detailed Photographs.....	19
8. FCC ID Label.....	23
9. Test Equipment.....	24

1. General Information

1.1 Notes

The test results of this report relate exclusively to the test item specified in 1.5. The KMO Lab does not assume responsibility for any conclusions and generalizations drawn from the test results with regard to other specimens or samples of the type of the equipment represented by the test item. The test report may only be reproduced or published in full. Reproduction or publication of extracts from the report requires the prior written approval of the KMO Lab.

1.2 Testing Laboratory

Ke Mei Ou Laboratory Co., Ltd.

7A, Jiexiangge, Jiahuixincheng, No.3027, Shennan Rd., Futian, Shenzhen, Guangdong, P.R.China.

Tel: +86 755 83642690 Fax: +86 755 83297077

Email: kmolab@tom.com

Internet: www.kmolab.com

1.3 Details of Applicant

Name : Shenzhen Lian Yi Da Science Co., Ltd.
Address : #2009A, Saige Building, Huaqiang Road North, Shenzhen China.
Contact : Mingsheng Deng / Manager
Tel : + 86 755 83681353
Fax : + 86 755 83681731

1.4 Application Details

Date of Receipt of Application : September 18, 2003
Date of Receipt of Test Item : September 18, 2003
Date of Test : September 28, 2003~October 13, 2003

1.5 Test Item

Manufacturer : Shenzhen Lian Yi Da Electron Factory
Address : Block B, Baoshan Industrial Park, Minzhi Village, Longhua Town, Baoan District, Shenzhen City
Contact : Xiaobo Wang / R&D
Tel : + 86 755 28169931
Fax : + 86 755 28169931
Brand Name : LYD
Model No. : LYD208CA, LYD203C
Description : Wireless Camera

Additional Information

Frequency : 2414.2MHz
Maximum Range : N/A
Number of Channels : Single
Transmitter Antenna : Directional
Power Supply : DC 5V
Current Consumption : 500 mA

1. 6 Test Standards

FCC 15 Subpart C, Paragraph 15.249: 2002

Note: All radiated measurements were made in all three orthogonal planes. The values reported are the maximum values.

2. Technical Test

2.1 Summary of Test Results

The EUT has been tested according to the following specifications:

Standard	Test Type	Result	Notes
FCC Part 15, Paragraph 15.207	Conducted Test	PASS	Complies
FCC Part 15 Subpart C Paragraph 15.249(a) and 15.249(b) Limit	Field Strength of Fundamental	PASS	Minimum passing margin is -27.67 dB at 2414.2 MHz Vertical
FCC Part 15, Paragraph 15.209	Radiated Test	PASS	Complies
FCC Part 15 Subpart C Paragraph 15.249(d) Limit	Measured Band Edges	PASS	Complies.

3. EUT Modifications

No modification by Ke Mei Ou Laboratory Co., Ltd.

4. Conducted Power Line Test

4.1 Test Equipment

Please refer to Section 9 this report.

4.2 Test Procedure

The EUT was tested according to ANSI C63.4 - 2001. The frequency spectrum from 0.15 MHz to 30 MHz was investigated. The LISN used was 50 ohm / 50 uHenry as specified by section 5.1 of ANSI C63.4 - 2001. cables and peripherals were moved to find the maximum emission levels for each frequency.

4.3 Test Setup

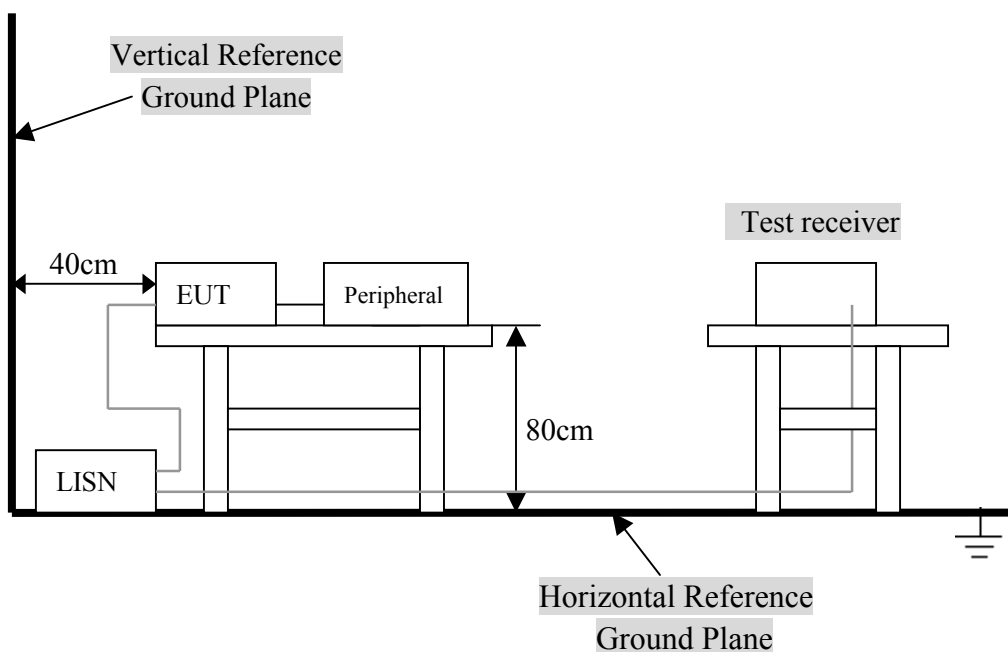

For the actual test configuration, Please refer to the related items – Photos of Testing.

4. 4 Configuration of the EUT

The EUT was configured according to ANSI C63.4-2001. EUT was used DC 5V (Power by Class 2 Adaptor). The operation frequency is from 2414.2MHz. Enable the signal transmitted from the external antenna from EUT to receiver. All interface ports were connected to the appropriate peripherals. All peripherals and cables are listed below.

A. EUT

Device	Manufacturer	Model #	FCC ID
Wireless Camera	Shenzhen Lian Yi Da Science Co., Ltd.	LYD208CA	RAWLYD208CA

B. Internal Devices

Device	Manufacturer	Model #	FCCID / DoC
N/A			

C. Peripherals

Device	Manufactruer	Modle # Serial #	FCC ID/ DoC	Cable
Wireless Receiver	Shenzhen Lian Yi Da Science Co., Ltd.	LYD208	N/A	No-Shielded, 1.2m

4. 5 EUT Operating Condition

Operating condition is according to ANSI C63.4 - 2001.

- A. Setup the EUT and simulators as shown on follow.
- B. Enable RF signal and confirm EUT active.
- C. Modulate output capacity of EUT up to specification.

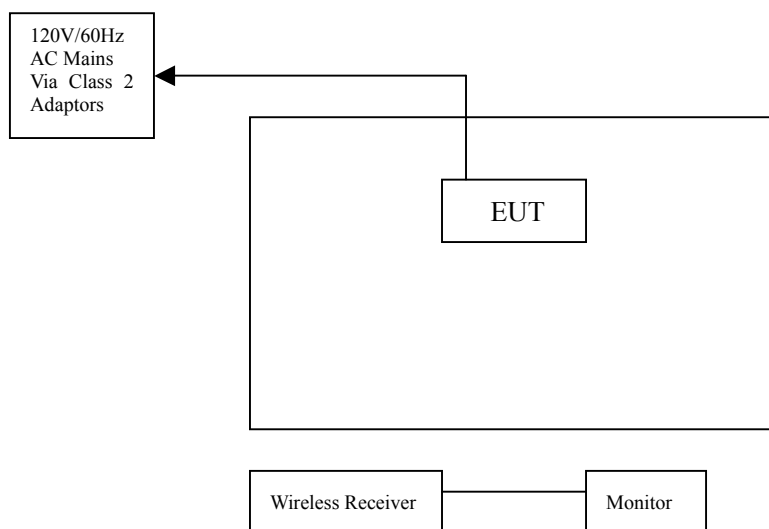

4. 6 Conducted Power Line Emission Limits

FCC Part 15 Paragraph 15.207 (dBuV)		
Frequency Range (MHz)	Class A QP/AV	Class B QP/AV
0.15 – 0.5	79/66	66-56/56-46
0.5 – 5.0	73/60	56/46
5.0 - 30	73/60	60/50

NOTE : In the above table, the tighter limit applies at the band edges.

4.7 Conducted Power Line Test Result

The frequency spectrum from 0.15 MHz to 30 MHz was investigated. All readings are quasi -peak values with a resolution bandwidth of 9 KHz.

- Temperature : 26 °C
- Humidity : 53 % RH

Note: The RF voltage was scanned from 150KHz to 30MHz on each AC lines (hot and neutral) of the EUT and no significant emissions were found in this frequency band.

Conducted Emission

EN55022

EUT: Wireless Camera M/N:LYD208CA

Manufacturer: Shenzhen Lian Yi Da Science Co., Ltd.

Operating Condition: Transmitter

Test Site: Ke Mei Ou Laboratory

Operator: Peter Lin

Test Specification: LINE&NEUTRAL

Comment:

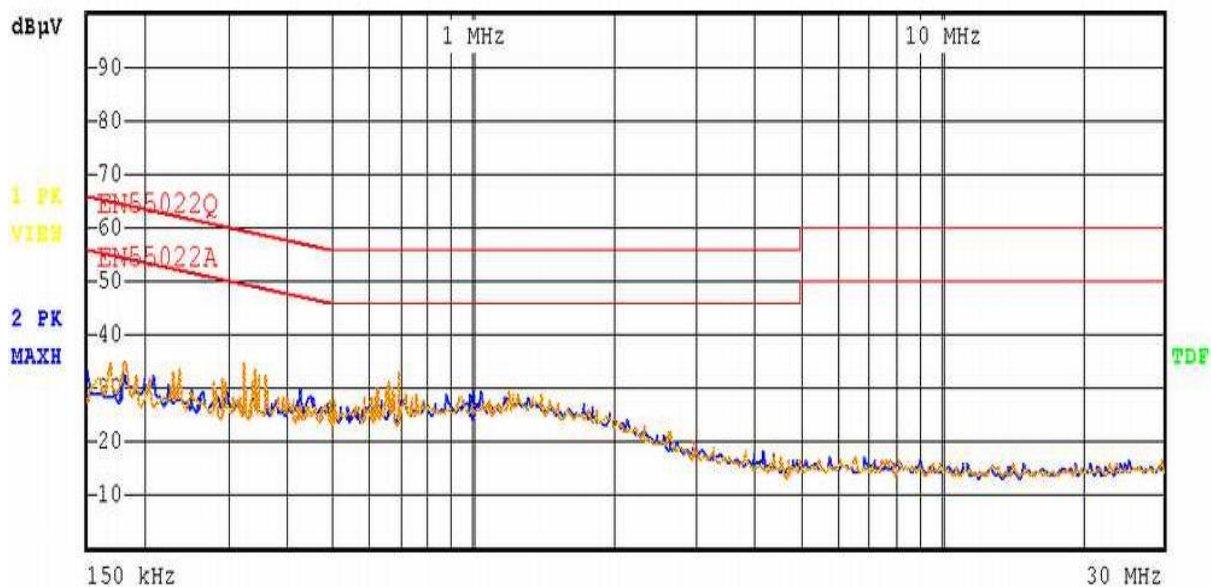

5. Radiated Emission Test

5.1 Test Equipment

Please refer to Section 9 this report.

5.2 Test Procedure

1. The EUT was tested according to ANSI C63.4 - 2001. The radiated test was performed at Ke Mei Ou Laboratory .This site is on file with the FCC laboratory division, Registration No. 125782.
2. The EUT, peripherals were put on the turntable which table size is 1m x 1.5 m, table high 0.8 m. All set up is according to ANSI C63.4-2001.
3. The frequency spectrum from 30 MHz to 1 GHz was investigated. All readings from 30 MHz to 1 GHz are quasi-peak values with a resolution bandwidth of 120 KHz. All readings are above 1 GHz , peak values with a resolution bandwidth of 1 MHz . Measurements were made at 3 meters.
4. The antenna high is varied from 1 m to 4 m high to find the maximum emission for each frequency.
5. Maximizing procedure was performed on the six (6) highest emissions to ensure EUT compliance is with all installation combinations. All data was recorded in the peak detection mode. Quasi-peak readings was performed only when an emission was found to be marginal (within -4 dB of specification limit), and are distinguished with a "QP" in the data table.
6. The antenna polarization: Vertical polarization and Horizontal polarization.

5.3 Radiated Test Setup

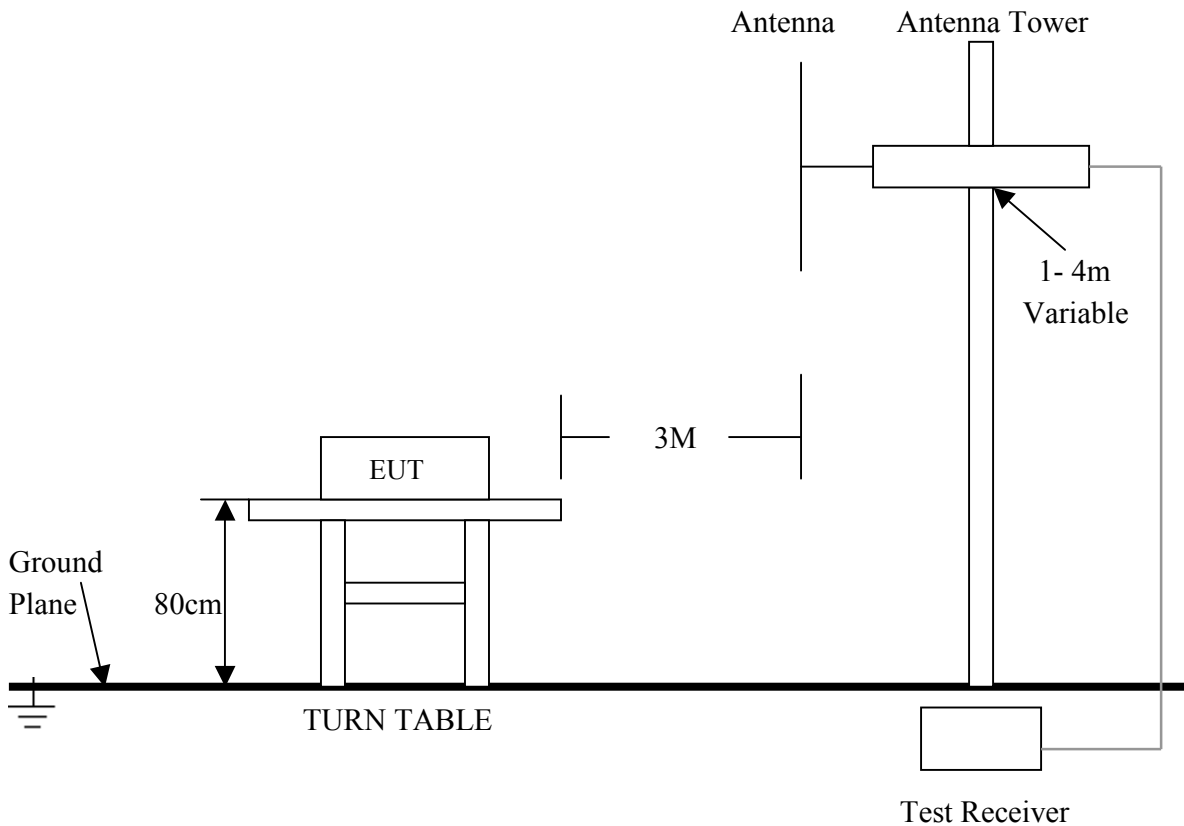

For the actual test configuration, please refer to the related items – Photos of Testing.

5.4 Configuration of the EUT

Same as section 4.4 of this report

5.5 EUT Operating Condition

Same as section 4.5 of this report.

5.6 Radiated Emission Limit

All emission from a digital device, including any network of conductors and apparatus connected thereto, shall not exceed the level of field strength specified below :

A. FCC Part 15 Subpart C Paragraph 15.249(a) Limit

Fundamental Frequency (MHz)	Field Strength of Fundamental (3m)		Field Strength of Harmonics (3m)	
	mV/m	dBuV/m	uV/m	dBuV/m
902~928	50	94(Average) 114(Peak)	500	54(Average) 74(Peak)
2400~2493.5	50	94(Average) 114(Peak)	500	54(Average) 74(Peak)

- Note:**
- (1) RF Voltage (dBuV) = 20 log RF Voltage (uV)
 - (2) Distance refers to the distance in meters between the measuring instrument antenna and the closed point of any part of the device or system.
 - (3) The emission limit in this paragraph is based on measurement instrumentation employing an average detector. Measurement using instrumentation with a peak detector function, corresponding to 20dB above the maximum permitted average limit.

B. Frequencies in restricted band are complied to limit on Paragraph 15.209.

Frequency (MHz)	Distance (m)	Field Strength (dBuV/m)
30 - 88	3	40.0
88 - 216	3	43.5
216 - 960	3	46.0
ABOVE 960	3	54.0

- Note:**
- (1) RF Voltage (dBuV) = 20 log RF Voltage (uV)
 - (2) In the Above Table, the tighter limit applies at the band edges.
 - (3) Distance refers to the distance in meters between the measuring instrument antenna and the closed point of any part of the device or system.

5. 7 Radiated Emission Test Result

A. Fundamental Radiated Emission Data

Product : Wireless Camera Test Mode : Transmitter
 Test Item : Fundamental Radiated Emission Data Temperature : 25 °C
 Test Voltage : DC 5V (Power by Class 2 Adaptor) Humidity : 56%RH
 Test Result : **PASS**

Freq. (MHz)	Emission (dBuV/m)	HORIZ / VERT	Limits (dBuV/m)	Margin (dB)
2414.2	85.80	HORIZ	114	-28.20
2414.2	86.33	VERT	114	-27.67

Note: (1) All Readings are Peak value.
 (2) Emission Level = Reading Level + Probe Factor + Cable Loss.
 (3) The average measurement was not performed when the peak measured data under the limit of average detection.

B. Harmonics Radiated Emission Data

Product : Wireless Camera Test Mode : Transmitter
 Test Item : Harmonics Radiated Emission Data Temperature : 25 °C
 Test Voltage : DC 5V (Power by Class 2 Adaptor) Humidity : 56%RH
 Test Result : **PASS**

Freq. (MHz)	Emission (dBuV/m)	HORIZ / VERT	Limits (dBuV/m)	Margin (dB)
4828.1	61.3	HORZ	74.0	-12.7
4828.0	61.1	VERT	74.0	-12.9
7242.2	54.2	HORZ	74.0	-19.8
7242.2	54.8	VERT	74.0	-19.2
9656.6	52.4	HORZ	74.0	-21.6
9656.5	52.3	VERT	74.0	-21.7
12070.3	42.3	HORZ	74.0	-31.7
12070.1	41.0	VERT	74.0	-33.0

Note: (1) All Reading Levels below 1GHz are Quasi-Peak, above are peak and average value.
 (2) Emission Level = Reading Level + Probe Factor + Cable Loss.

C. General Radiated Emission Data

Product	: Wireless Camera	Test Mode	: Transmitter
Test Item	: General Radiated Emission Data	Temperature	: 25 °C
Test Voltage	: DC 5V (Power by Class 2 Adaptor)	Humidity	: 56%RH
Test Result	: PASS		

Freq. (MHz)	Emission (dBuV/m)	HORIZ / VERT	Limits (dBuV/m)	Margin (dB)
114.012	18.65	HORIZ	43.5	-24.85
114.011	18.56	VERT	43.5	-24.94
150.032	22.10	HORIZ	43.5	-21.40
150.025	25.54	VERT	43.5	-17.96
250.036	21.43	HORIZ	46.0	-24.57
250.000	23.45	VERT	46.0	-22.55
384.075	26.51	HORIZ	46.0	-19.49
384.075	26.39	VERT	46.0	-19.61
500.126	19.80	HORIZ	46.0	-26.20
336.075	20.39	VERT	46.0	-25.61
729.864	20.15	HORIZ	46.0	-25.85
729.879	19.24	VERT	46.0	-26.76

Note:

- (1) All Reading Levels below 1GHz are Quasi-Peak, above are peak and average value.
- (2) Emission Level = Reading Level + Probe Factor + Cable Loss.

6. Band Edge

6.1 Test Equipment

Please refer to Section 9 this report.

6.2 Test Procedure

1. The EUT was tested according to ANSI C63.4 - 2001. The radiated test was performed at Ke Mei Ou Laboratory. This site is on file with the FCC laboratory division, Registration No. 125782.
2. The EUT, peripherals were put on the turntable which table size is 1m x 1.5 m, table high 0.8 m. All set up is according to ANSI C63.4-2001.

6.3 Radiated Test Setup

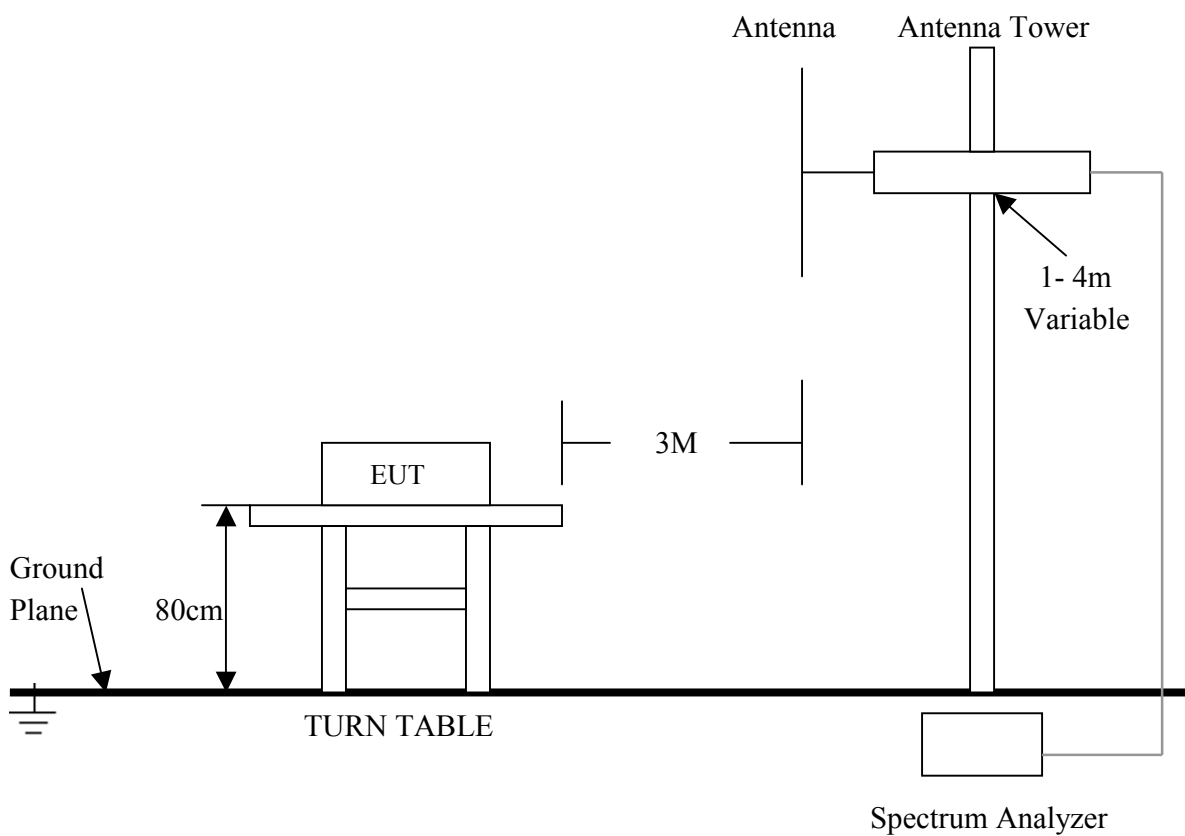

For the actual test configuration , please refer to the related items – Photos of Testing

6. 4 Configuration of The EUT

Same as section 4 . 4 of this report

6. 5 EUT Operating Condition

Same as section 4 . 5 of this report.

6. 6 Band Edge FCC 15.249(d) Limit

In any 100kHz bandwidth outside the frequency band in which the spread spectrum intentional radiator is operating, the radio frequency power that is produced by the intentional radiator shall be at least 50dB below that in the 100kHz bandwidth within the band that contains the highest level of the desired power, based on either an RF conducted or a radiated measurement, Attenuation below the general limits specified in Section 15.209(a) is not required. In addition, radiated emissions which fall in the restricted bands, as defined in Section 15.205(a), must also comply with the radiated emission limits specified in Section 15.209(a) (see Section 15.205(c)).

6. 7 Band Edge Test Result

Product	: Wireless Camera	Test Mode	: Transmitter
Test Item	: Band Edge	Temperature	: 25 °C
Test Voltage	: DC 5V (Power by Class 2 Adaptor)	Humidity	: 56%RH
Test Result	: PASS		

Freq. (MHz)	Emission (dBuV/m)	Limits (dBuV/m)	Margin (dB)
2393.800	30.68	74.0	-43.32

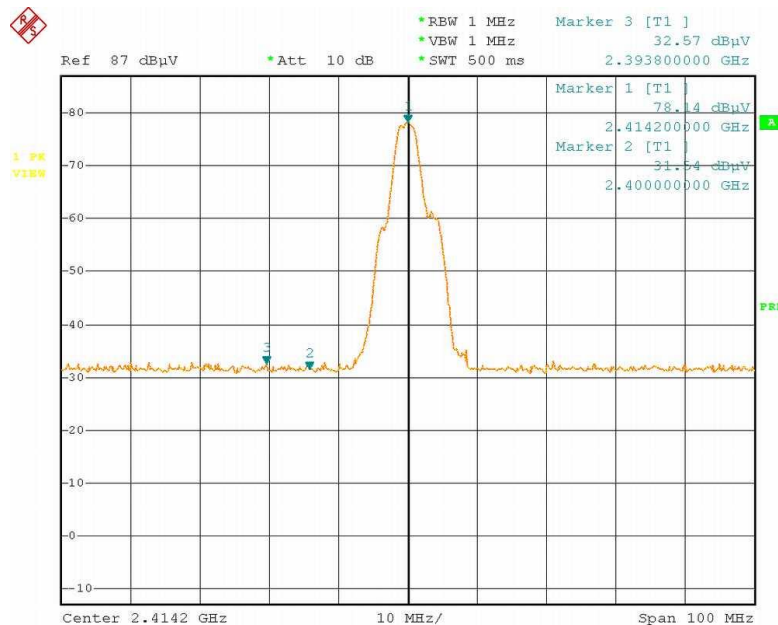

Date: 13.OCT.2003 21:27:20

- Note:**
- (1) The field strength of any emissions which appear outside of this band shall not exceed the general radiated emission limits in Section 15.209.
 - (2) The average measurement was not performed when the peak measured data under the limit of average detection.

7. Photos of Testing

7.1 EUT Test Photographs

Conducted emission test view



Radiated emission test view

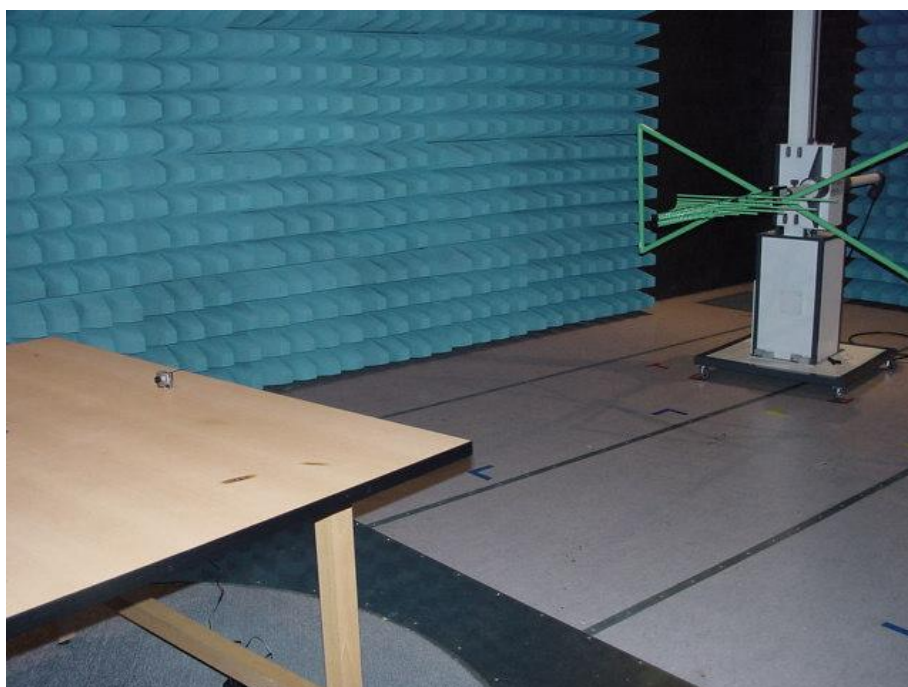

7.2 EUT Detailed Photographs

(1) EUT top view

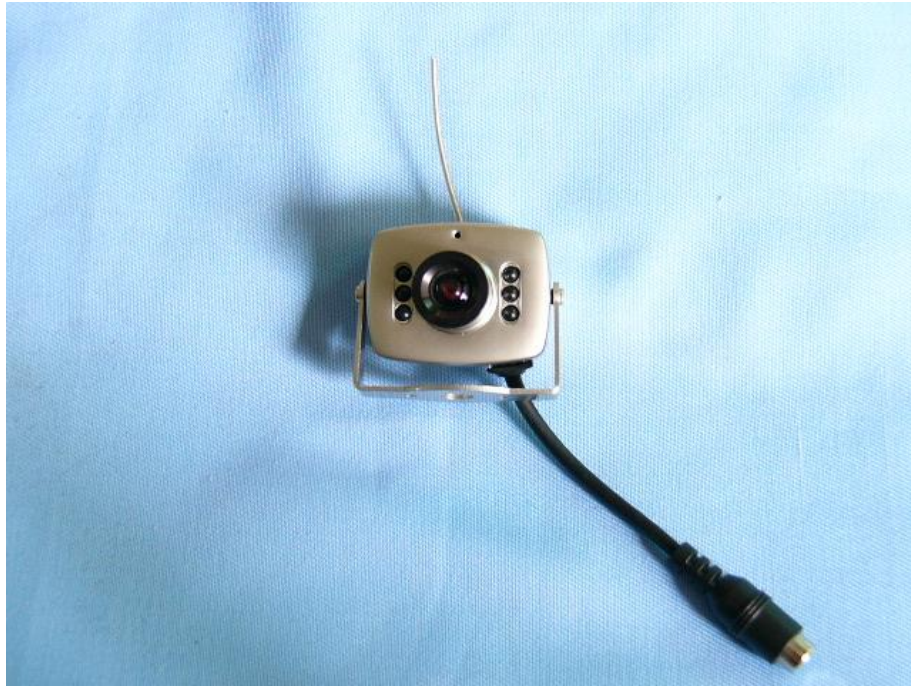

(2) EUT bottom view



(3) EUT inside whole view

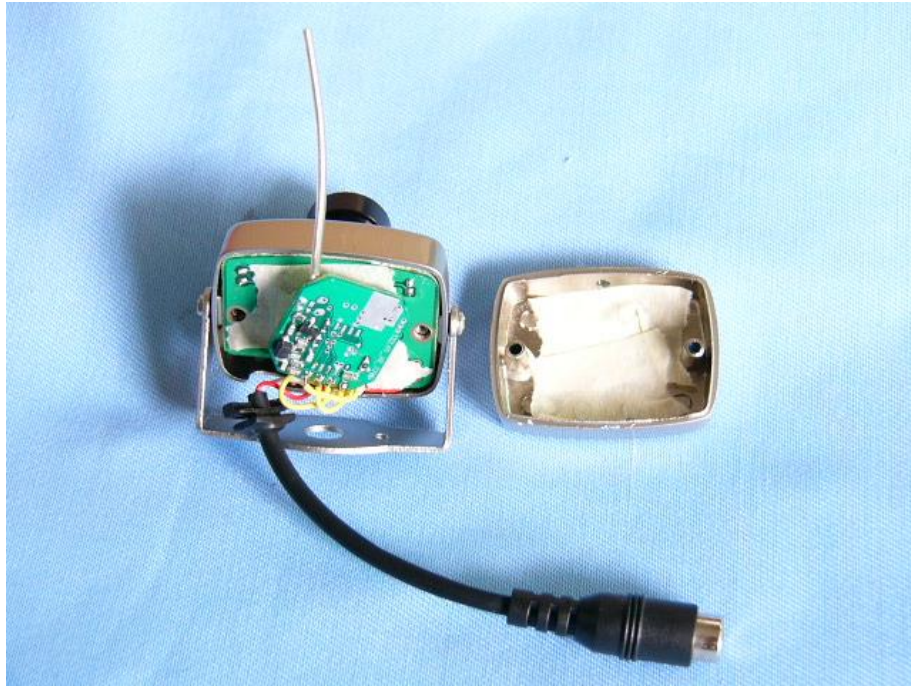

(4) Main&RF board component side

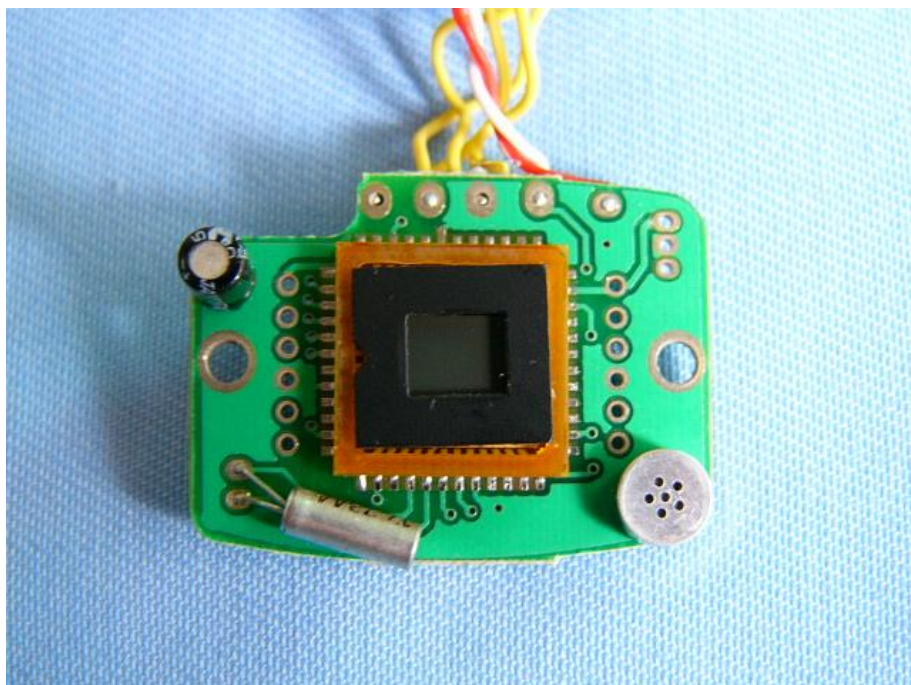

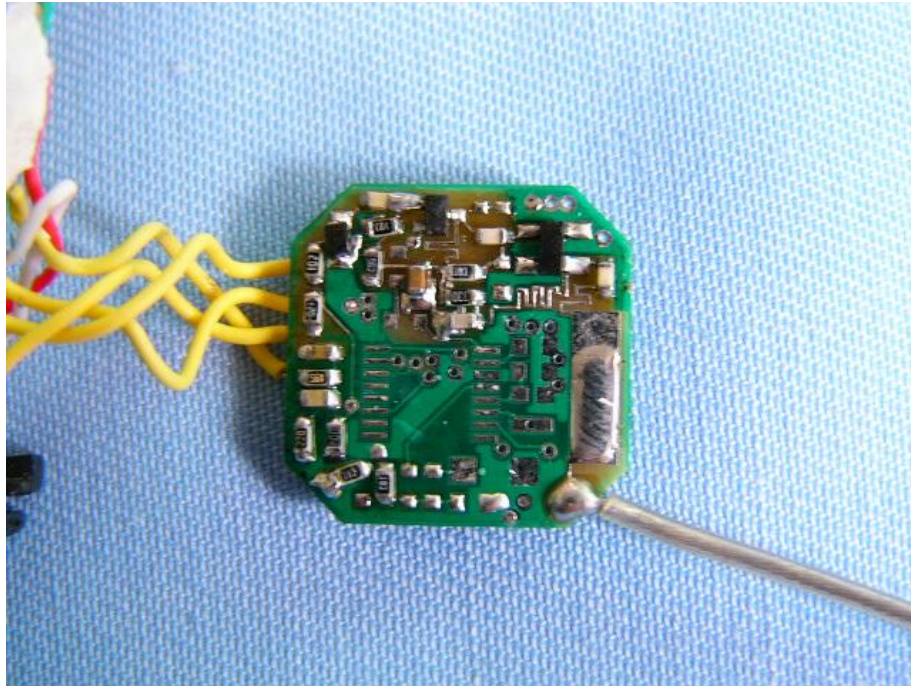

(5) Main&RF board solder side



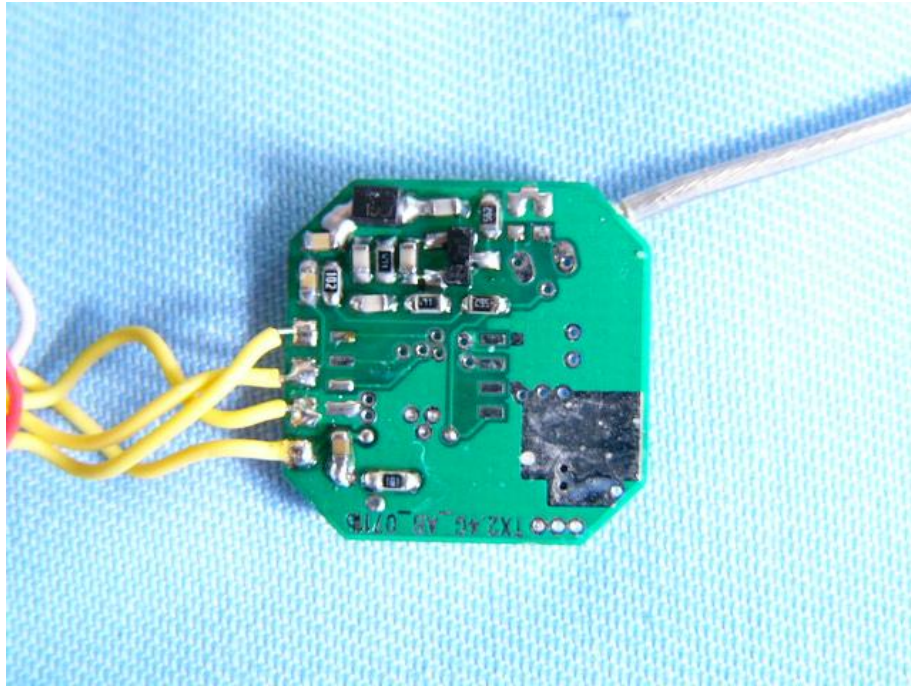

8. FCC ID Label

FCC ID: RAWLYD208CA

This device complies with Part 15 of the FCC Rules. Operation is subject to the following two conditions: (1) this device may not cause harmful interference, and (2) this device must accept any interference received, including interference that may cause undesired operation.

The Label must not be a stick-on paper label. The Label on these products must be permanently affixed to the product and readily visible at the time of purchase and must last the expected lifetime of the equipment not be readily detachable.

Proposed Label Location on EUT

EUT Bottom View/Proposed FCC ID Location



9. Test Equipment

The following test equipments were used during the radiated & conducted emission test:

Equipment/ Facilities	Manufacturer	Model #	Serial No.	Date of Cal.	Due Date
Turntable	KMO	KSZ001T	200306	NCR	NCR
Antenna Tower	KMO	KSZ002AT	200307	NCR	NCR
OATS	KMO	KSZSITE001	N/A	July 06, 2003	July 06, 2004
EMI Test Receiver	Rohde & Schwarz	ESPI3	100180	Oct.18, 2002	Oct.18, 2003
Signal Generator	Rohde & Schwarz	SMT03	100059	Feb.01, 2003	Feb.01, 2004
Bilog Antenna	Chase	CBL6111C	2576	Feb.01, 2003	Feb.01, 2004
Ultra Broadband Antenna	Rohde & Schwarz	HL 562	100110	June.05, 2003	June.05, 2004
AMN	Rohde & Schwarz	ESH3-Z5	100196	Oct. 23,2003	Oct. 23, 2004
AMN	Rohde & Schwarz	ESH3-Z5	100197	Oct. 23,2003	Oct. 23, 2004
Pulse Limiter	Rohde & Schwarz	ESH3-Z2	N/A	N/A	N/A
KMO Shielded Room	KMO	KMO-001	N/A	N/A	N/A
EMI Test Receiver	Rohde & Schwarz	ESCS30	100003	Feb. 27, 2003	Feb.27, 2004
AMN	Rohde & Schwarz	ESH3-Z5	100002	Feb. 01, 2003	Feb.01, 2004
LISN	Kyoritsu	KNW-407	8-1441-8	Feb. 23, 2003	Feb.23, 2004
EMI Test Receiver	Rohde & Schwarz	ESI26	838786/013	Feb. 01, 2003	Feb.01, 2004
Bilog Antenna	Chase	CBL6112B	2591	Feb. 01, 2003	Feb.01, 2004
Horn Antenna	Rohde & Schwarz	HF906	100014	Feb. 01, 2003	Feb.01, 2004
Radio Communication Test Set	IFR	2955B	100015	Feb 01, 2003	Feb 01, 2004
Multifunction Synthesizer	Hewlett-Packard	8904A	100016	Feb 01, 2003	Feb 01, 2004
Temperature Chamber	TABAI	PSL-4GTW	N/A	Feb 06,2003	Feb 06, 2004
3m Semi-Anechoic Chamber	Albatross Projects	9mX6mX6m	N/A	Feb. 01, 2003	Feb.01, 2004