

4.3.1 AIS Transponder Block Diagram

4.3 Description of the Components

MX531

Fig. 4-3 Block diagram of the Transponder Unit

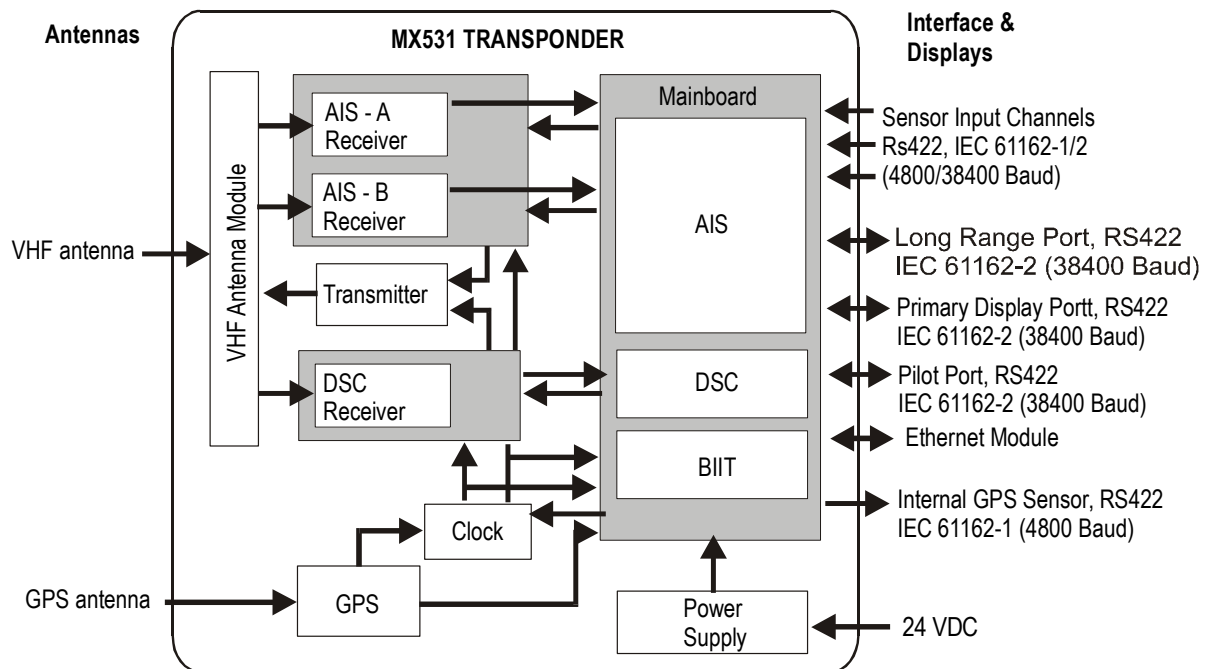

The Block diagram of the Transponder Unit shows the internal structure of the AIS Electronics Unit with the following parts:

VHF Radio

- VHF Receiver AIS Channel A
- VHF Receiver AIS Channel B
- VHF Receiver DSC Channel 70
- VHF Transmitter

GPS

- 12-channel GPS chip

Motherboard and Peripheral Components