



Report No: SYBH(R)142102007EB-1
FCC ID: QISC209S

FCC TEST REPORT OF CDMA 1X Digital Mobile Phone

M/N: HUAWEI C209s

DEC. 06, 2007

Reliability Laboratory of Huawei Technologies Co., Ltd.

All Right Reserved

Notice

1.	The laboratory has obtained the accreditation of China National Accreditation Service for Conformity Assessment (CNAS), and accreditation number: L0310.
2.	The laboratory has obtained the accreditation of THE AMERICAN ASSOCIATION FOR LABORATORY ACCREDITATION (A2LA), and Accreditation Council Certificate Number: 2174.01.
3.	The laboratory has been listed on the US Federal Communications Commission list of test facilities recognized to perform electromagnetic emissions measurements. The site recognition number is 97456.
4.	The laboratory also has been listed by the VCCI to perform EMC measurements. The accreditation number is C1758, R1672, and T153.
5.	The test report is invalid if not marked with "exclusive stamp for the test report".
6.	Any copy of the test report is invalid if not re-marked with the "exclusive stamp for the test report".
7.	The test report is invalid if not marked with the stamps or the signatures of the persons responsible for performing, revising and approving the test report.
8.	The test report is invalid if there is any evidence of erasure and/or falsification.
9.	If there is any dissidence for the test report, please file objection to the test centre within 15 days from the date of receiving the test report.
10.	Normally, the test report is only responsible for the samples that have undergone the test.
11.	Context of the test report cannot be used partially or in full for publicity and/or promotional purposes without previous written approval of the laboratory.

REPORT ON FCC TEST REPORT OF CDMA 1X Digital Mobile Phone

M/N: HUAWEI C209s

Report No: SYBH(R)142102007EB-1

REGULATION **FCC CFR47 Part 2: Subpart J;**
FCC CFR47 Part 24: Subpart E;
FCC CFR47 Part 15: Subpart B;

CONCLUSION There are 10 items need to be tested, 10 items have been tested. The sample of the model completely meets the requirements

Final Judgement: Pass

General Manager

2007.12.06

Date

张兴海

Name

signature



**Technical Responsibility
For Area of Testing**

2007.12.05

Date

余 辉

Name

signature



Test Lab Engineer

2007.12.05

Date

胡 俊

Name

signature

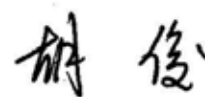

Contents

1	<u>Summary</u>	5
2	<u>Product Description</u>	6
2.1	PRODUCTION INFORMATION	6
2.2	MODIFICATION INFORMATION.....	6
3	<u>Test Site Description</u>	7
3.1	TESTING PERIOD	7
3.2	GENERAL SET UP DESCRIPTION	7
4	<u>Product Description</u>	8
4.1	TECHNICAL CHARACTERISTICS	8
4.2	EUT IDENTIFICATION LIST	10
5	<u>Main Test Instruments</u>	11
6	<u>Transmitter Measurements</u>	12
6.1	EFFECTIVE ISOTROPIC RADIATED POWER OF TRANSMITTER (EIRP).....	12
6.2	CONDUCTED OUTPUT POWER	15
6.3	MODULATION CHARACTERISTICS	17
6.4	OCCUPIED BANDWIDTH.....	19
6.5	BAND EDGES COMPLIANCE	21
6.6	SPURIOUS EMISSION AT ANTENNA TERMINAL	23
6.7	RADIATED SPURIOUS RADIATION.....	25
6.8	FREQUENCY STABILITY	29
7	<u>EMC Test</u>	33
7.1	CONDUCTED EMISSION AT POWER PORT	33
7.2	RADIATED EMISSION OF ENCLOSURE IN IDLE MODE	36
8	<u>System Measurement Uncertainty</u>	39
9	<u>Appendixes</u>	40

1 Summary

The table below summarizes the measurements and results for the CDMA 1X Digital Mobile Phone HUAWEI C209s. Detailed results and descriptions are shown in the following pages.

Table 1 Summary of results

FCC Measurement Specification	FCC Limits Part(s)	Description	Result
2.1046	24.232	Effective Isotropically Radiated Power of Transmitter	PASS
2.1046	24.232	Conducted Power of Transmitter	PASS
2.1047		Modulation Characteristics	PASS
2.1049		Occupied Bandwidth	PASS
2.1051	24.238	Band Edges Compliance	PASS
2.1051	24.238	Spurious Emission at Antenna Terminals	PASS
2.1053	24.238	Radiated Spurious Emissions	PASS
2.1055	24.235	Frequency Stability	PASS
-	15.107	Conducted Emission at Power Port	PASS
-	15.109	Radiated Emission of Enclosure in Idle Mode	PASS

2 Product Description

2.1 Production Information

2.1.1 General Description

The CDMA 1X Digital Mobile Phone HUAWEI C209s is subscriber equipment in the CDMA system. The frequency band is PCS band. The Mobile Phone implements such functions as RF signal receiving / Transmitting, CDMA protocol processing, voice and SMS service etc.

2.1.2 Support function and Service

The Mobile Station C209s support the function and service as follows:

Table 2 Service and Test mode List

Service Name	Characteristic	Corresponding Test Mode	Note
voice and SMS	Modulation: QPSK	TM1*	
voice and SMS	Modulation: HPSK	TM3*	

Note: * Refer to ANSI/TIA-98-E section 1.3 for the information of TM (Test Mode).

2.2 Modification Information

For original equipment, following table is not application.

Table 3 Modification Information

Model Number	Board/Module	Original Version	New Version	Modify Information
Not applicable!				
Not applicable!				
Not applicable!				

3 Test Site Description

The test site of:

Huawei Technologies Co. Ltd.
P.O. Box 518129
Huawei base, bantian,
Longgang District, Shenzhen, China

The test site description has been submitted to  and registration granted under the registration number **97456** on March 11, 2003. The test site has been accredited by



and the accredited number is **2174.01** in Jan of 2004.

3.1 Testing Period

The test have been performed during the period of

November 12, 2007 to December 04, 2007

3.2 General Set up Description

The CDMA 1X Digital Mobile Phone HUAWEI C209s can support CDMA mode and PCS Band. During this measurement, the Mobile Station just works in CDMA mode and PCS Band.

TM1: Forward Traffic Channel Radio Configuration 1, Reverse Traffic Channel Radio Configuration 1

TM3: Forward Traffic Channel Radio Configuration 3, Reverse Traffic Channel Radio Configuration 3

Parameter	Units	Value
\hat{I}_{or}	dBm/1.25 MHz	-104
$\frac{Pilot Ec}{I_{or}}$	dB	-7
$\frac{Traffic Ec}{I_{or}}$	dB	-7.4

4 Product Description

4.1 Technical Characteristics

4.1.1 Frequency Range

Table 4 Frequency Range

Uplink band:	1850 to 1910 MHz
Downlink band:	1930 to 1990 MHz

4.1.2 Channel Spacing / Separation

Table 5 Channel Spacing / Separation

Channel spacing:	50 kHz
Channel separation:	1.25 MHz

4.1.3 Type of Emission

Table 6 Type of Emission

Emission Designation:	1M25F9W
-----------------------	----------------

According to CFR 47 (FCC) part 2, subpart C, section 2.201 and 2.202

4.1.4 Environmental Requirements

Table 7 Environmental Requirements

Minimum temperature:	- 10 °C
Maximum temperature:	+ 55 °C
Relative Humidity:	5% ~ 95%RH

4.1.5 Power Source

Table 8 Power Source

AC voltage nominal:	~120V
AC voltage range	~100V - 240V
AC current maximal:	200mA

4.1.6 Tune-up Procedure

According to CFR (FCC) part 2, subpart 2, section 2.1033 (9)

Please reference the document Tune-up Procedure in TCF.

4.1.7 Applied DC Voltages and Currents

According to CFR (FCC) part 2, subpart 2, section 2.1033 (8)
 The voltage and current in the final RF stage is:

Table 9 Applied RF module DC Voltages and Currents

Voltage:	== 2.85VDC
Current:	150mA According to CFR (FCC) part 2, subpart 2, section 2.1033 (8)

4.2 EUT Identification List

4.2.1 Board Information

Table 10 Board Information

1900MHz CDMA 1X Digital Mobile Phone		
C209s		
Board and Module		
Equipment Designation / Description	Serial Number	Remarks
-Main board	020GJS7N7A344276	HC1C208SM
-LCD	17060950A0011D	WD-G1206WT-6WLVa
-Battery	BYD7A2937103	HBC80S

4.2.2 Adapter Technical Data

AC/DC Adapter Model :	TPCA-053065E	XQLCHW03
Manufacturer :	TECH-POWER ELECTRONICS (SHENZHEN) CO.,LTD.	Shenzhen OCT Xinqiao Technology Co.,LTD.
Input Voltage :	~ 100-240V ~50/60Hz	~ 100-240V ~50/60Hz
Output Voltage :	=== 5.3V	=== 5.3V
Rated Power :	4W	4W
S/N :	TPI721295906	AKD790216358

4.2.3 Battery Technical Data

Battery Model: HBC80S
 Rated capacity: 800mAh
 Nominal Voltage: === 3.7V
 Charging Voltage: === 4.2V

4.2.4 FCC Identification

Grantee Code: QIS
Product Code: C209S
FCC Identification: QISC209S

5 Main Test Instruments

Table 11 Main Test Equipments

Equipment Description	Manufacturer	Model	Serial Number	Calibrated until (MM.DD.YYYY)
Test Receiver Display Unit	R&S	ESMI 804.8932.52	829214/011	04.22.2008
Test Receiver RF Unit	R&S	ESMI 1032.5640.53	829550/008	04.22.2008
Receiver	R&S	ESIB 26	100318	05.21.2008
Receiver	R&S	ESCS30	830245/018	05.29.2008
Pre-Amplifier	Agilent	8447D	2944A10146	05.21.2008
Pre-Amplifier	Agilent	83017A	3950M00246	05.21.2008
Loop Antenna	Schwarzbeck	FMZB1516	1516115	05.29.2008
BiLog Antenna	Schaffner	CBL 6112B	2747	02.25.2008
BiLog Antenna	Schaffner	CBL 6112B	2536	06.07.2008
Horn Antenna	ETS-Lindgren	3117	00062549	06.05.2008
Horn Antenna	ETS-Lindgren	3116	00031541	03.20.2008
Dipole	Schwarzbeck	D69250-UHAP/D69250-VHAP	979/917	08.27.2008
Signal Generator	R&S	SMT06	830264/009	09.29.2008
Signal Generator	R&S	SMR 40	100325	12.09.2007
Artificial Mains Network	R&S	ENV4200	100001	07.20.2008
Power Supply	Keithley	2306	1045337	08.14.2008
Climate Chamber	WEISS	ACS-1	3604040034	06.05.2008
Universal Radio Communication Tester	R&S	CMU200	108035	07.19.2008
Wireless communication test set	Agilent	8960	GB43461081	08.23.2008
Spectrum Analyzer	R&S	FSU26	200002	08.21.2008

6 Transmitter Measurements

6.1 Effective Isotropic Radiated Power of Transmitter (EIRP)

6.1.1 Test Conditions

Table 12 Test Conditions

Preconditioning:	1 hour
Measured at:	enclosure
Ambient temperature:	24
Relative humidity:	54%
Test Configurations:	TM1 and TM3 at frequency B、 M、 T

6.1.2 Test Specifications and Limits

6.1.2.1 Specification

CFR 47 (FCC) part 2.1046 and part 24.232

6.1.2.2 Supporting Standards

Table 13 Supporting Standards:

ANSI/TIA-603-C: 2004	Land Mobile FM or PM Communications Equipment Measurement and Performance Standards
ANSI/TIA-98-E: 2003	Recommended Minimum Performance Standards for cdma2000 Spread Spectrum Mobile Stations

6.1.2.3 Limits

Compliance with part 24.232, in no any case may the peak power of a mobile station transmitter exceed 2 W. And calculate longitude EIRP by following formula : $EIRP(dBm) = 10 * \log(EIRP_{in\ mwatts})$.
 $EIRP(dBm) = ERP(dBm) + 2.15dB$.

Test 14 Limits

Maximum Output Power (Watts)	< 2 Watts
Maximum Output Power (dBm)	< 33 dBm

6.1.3 Test Method and Setup

- For transmitters other than single sideband, independent sideband and controlled carrier radiotelephone, E.I.R.P. shall be measured when the transmitter is adjusted in accordance with the tune-up procedure to give the values of current and voltage on the circuit elements specified in 2.1033(c)(8). Connect the Mobile Station to the wireless communication tester Agilent 8960 via the air interface. The band class is set as PCS band.
- Test the Radiated maximum output power by the Agilent 8960 received from test antenna.
- Use substitution method to verify the Maximum output power. The EUT is substituted by a dipole antenna. The dipole is connected to a signal generator. And then adjust the output level of the signal generator to get the same received power recorded in step (b) on Agilent 8960, and record the power level of Signal Generator. Of course, the cable loss at the test frequency should be compensated.

Test setup

Step 1: Pre-test

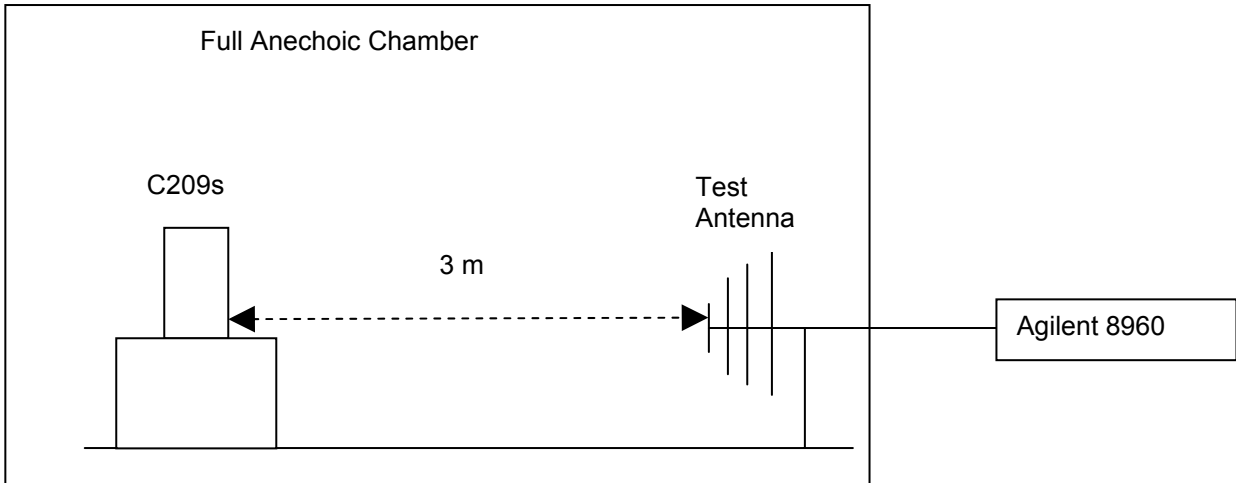

Step 2: Substitution method to verify the maximum EIRP

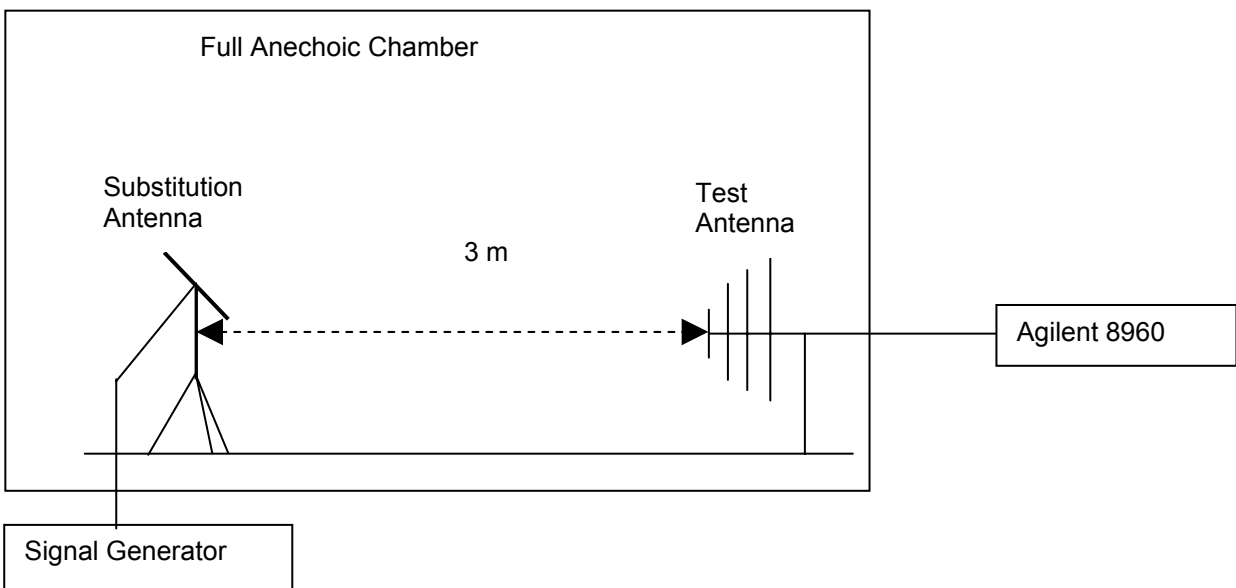

Figure 1. Test Set-up

NOTE:

1. Effective radiated power (ERP) refers to the radiation power output of the EUT, assuming all emissions are radiated from half-wave dipole antennas substitution Results.
2. Effective Isotropic Radiated Power (EIRP). The product of the power supplied to the antenna and the antenna gain in a direction relative to an isotropic antenna.

6.1.3.1 Measurement Results

Table 15 Measurement Results

TEST CONDITIONS	RF Output Power		
	Channel25(B) 1851.25MHz	Channel 600(M) 1880.00MHz	Channel 1175(T) 1908.75MHz

		dBm		dBm		dBm	
		Measured	Limit	Measured	Limit	Measured	Limit
TM1	T _{nom} (24 °C) V _{nom} (3.7 V)	20.95	33	21.02	33	20.93	33
TM3	T _{nom} (24 °C) V _{nom} (3.7 V)	20.83	33	20.97	33	20.96	33

6.1.3.2 Substitution Results

Table 16 Substitution Results

Test Mode	Freq. [MHz]	Meas. Level [dBm]	Substitution Antenna Type	SGP [dBm]	Substitution Gain [dBi]	Cable Loss [dB]	Substitution Level (EIRP) [dBm]	Limit [dBm]	Result
TM1	1851.25	20.95	Dipole Ant.	16.75	5.18	1.0	20.93	33	Pass
TM1	1880.00	21.02	Dipole Ant.	16.59	5.46	1.0	21.05	33	Pass
TM1	1908.75	20.93	Dipole Ant.	16.14	5.77	1.0	20.91	33	Pass
TM3	1851.25	20.83	Dipole Ant.	16.67	5.18	1.0	20.85	33	Pass
TM3	1880.00	20.97	Dipole Ant.	16.50	5.46	1.0	20.96	33	Pass
TM3	1908.75	20.96	Dipole Ant.	16.21	5.77	1.0	20.98	33	Pass

Note: a, For get the EIRP (Effective Isotropic Radiated Power) in substitution method, the following formula should take to calculate it,

$$\text{EIRP [dBm]} = \text{SGP [dBm]} - \text{Cable Loss [dB]} + \text{Gain [dBi]}$$

SGP: Signal Generator Level

b, A CDMA signal with bandwidth of 1.25MHz are created by the vector generator R&S SMU200A.

c, RBW=10kHz, VBW=300kHz, and integrated by the instrument to 1.25MHz.

6.1.4 Conclusion

The equipment **PASSED** the requirement of this clause.

6.2 Conducted output power

6.2.1 Test Conditions

Table 17 Test Conditions

Preconditioning:	0.5 hour
Measured at:	Antenna connector
Ambient temperature:	24
Relative humidity:	58%
Test Configurations:	TM1 and TM3 at frequency B、 M、 T

6.2.2 Test Specifications and Limits

6.2.2.1 Specification

CFR 47 (FCC) part 2.1046 and part 24.232

6.2.2.2 Supporting Standards

Table 18 Supporting Standards:

ANSI/TIA-603-C:2004	Land Mobile FM or PM Communications Equipment Measurement and Performance Standards
ANSI/TIA-98-E: 2003	Recommended Minimum Performance Standards for cdma2000 Spread Spectrum Mobile Stations

6.2.2.3 Limits

Compliance with part 24.232, in no any case may the peak power of a mobile station transmitter exceed 2 W. The calculated longitude EIRP by following formula:

$$\text{EIRP(dBm)} = 10 * \log (\text{EIRP}_{\text{in mwatts}}).$$

And for conducted power, we can use Antenna Gain to calculate the limit. So the conducted power:

$$P_{\text{cod}}(\text{dBm}) = \text{EIRP}(\text{dBm}) - \text{Gain}(\text{dBi}).$$

and $\text{Gain}(\text{dBi}) = \text{Gain}(\text{dBd}) + 2.15\text{dB}$

Table 19 Limits

Maximum Output Power (Watts)	< 2 Watts=33 dBm
Antenna Gain(dBi):	0dBi (Peak)
Maximum Conducted Output Power (dBm)	< 33dBm

6.2.3 Test Method and Setup

(a)For transmitters other than single sideband, independent sideband and controlled carrier radiotelephone, Conducted maximum power shall be measured when the transmitter is adjusted in accordance with the tune-up procedure to give the values of current and voltage on the circuit elements

specified in 2.1033(c)(8). Connect the Mobile Station to the wireless communication tester Agilent 8960 via the antenna connector. The band class is set as PCS band.
 (b)Test the Conducted maximum output power by the Agilent 8960.

Test setup

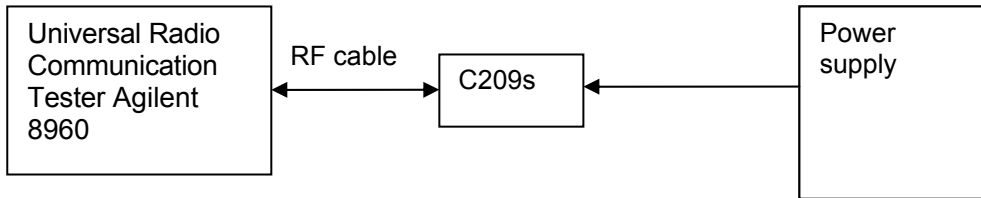

Figure 2. Test Set-up

6.2.4 Measurement Results

Table 20 Measurement Results

PCS band		RF Output Power					
TEST CONDITIONS		Channel 25(B) 1851.25MHz		Channel 600(M) 1880.00MHz		Channel 1175(T) 1908.75MHz	
		dBm		dBm		dBm	
		Measured	Limit	Measured	Limit	Measured	Limit
TM1	T _{nom} (25 °C) V _{nom} (3.7 V)	20.92	33	20.83	33	20.96	33
TM3	T _{nom} (25 °C) V _{nom} (3.7 V)	20.82	33	20.90	33	20.87	33

6.2.5 Conclusion

The equipment **PASSED** the requirement of this clause.

6.3 Modulation Characteristics

6.3.1 Test Conditions

Table 21 Test Conditions

Preconditioning:	1 hour
Measured at:	Antenna connector
Ambient temperature:	23.5 °C
Relative humidity:	57 %
Test Configurations:	TM1 and TM3 at frequency M

6.3.2 Test Specifications and Limits

6.3.2.1 Specification

CFR 47 (FCC) part 2.1047 and part 24 subpart E.

6.3.2.2 Supporting Standards

Table 22 Supporting Standards:

ANSI/TIA-603-C: 2004	Land Mobile FM or PM Communications Equipment Measurement and Performance Standards
ANSI/TIA-98-E: 2003	Recommended Minimum Performance Standards for cdma2000 Spread Spectrum Mobile Stations.

6.3.2.3 Limits

No specific modulation characteristics requirement limits in part 2.1047 and part 24 subpart E.

Table 23 Limits

Limits	Not applicable
--------	----------------

6.3.3 Test Method and Setup

Connect the Mobile Station to the Universal Radio Communication Tester CMU200 via the antenna connector. The band class is set as PCS band; the Mobile Station's output is matched with 50 Ω loads. Test method was according to ANSI/TIA-98-E. The waveform quality and constellation of the Mobile Station was tested.

Test setup

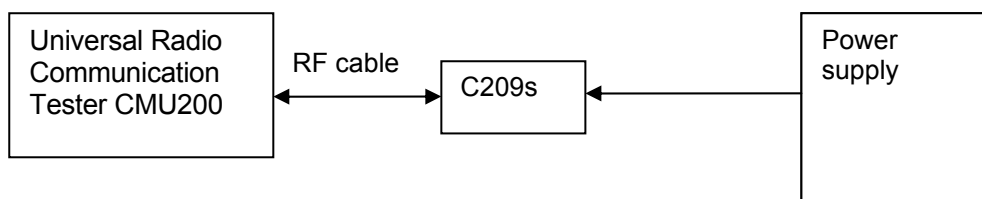

Figure 3. Test Set-up

6.3.4 Measurement Results

Table 24 Measurement Results

TEST CONDITIONS		Modulation Characteristic	
		Channel 600(M) 1880.00Mhz	
		Measured	
		TM1	TM3
T _{nom} (+25 °C)	V _{nom} (3.7V)	Refer to Appendix A	Refer to Appendix A

6.3.5 Conclusion

The equipment **PASSED** the requirement of this clause.

For the measurement results refer to appendix A.

6.4 Occupied Bandwidth

6.4.1 Test Conditions

Table 25 Test Conditions

Preconditioning:	1 hour
Measured at:	RF connector
Ambient temperature:	26 °C
Relative humidity:	53 %
Test Configurations:	TM1 and TM3 at frequency B、 T

6.4.2 Test Specifications and Limits

6.4.2.1 Specification

CFR 47 (FCC) part 2.1049 and part 24 subpart E.

6.4.2.2 Supporting Standards

Table 26 Supporting Standards:

ANSI/TIA-603-C: 2004	Land Mobile FM or PM Communications Equipment Measurement and Performance Standards
ANSI/TIA-98-E: 2003	Recommended Minimum Performance Standards for cdma2000 Spread Spectrum Mobile Stations.

6.4.2.3 Limits

No specific occupied bandwidth requirement in part 24 subpart E, but the occupied bandwidth was defined in part 2.1049: the frequency bandwidth such that, below its lower and above its upper frequency limits, the mean powers radiated are each equal to 0.5 percent of the total mean power radiated by a given emission shall be measured.

Table 27 Limits

Upper /lower frequency limits	0.5% of the mean power
-------------------------------	------------------------

6.4.3 Test Method and Setup

Mobile Station was connected to the wireless communication test set Agilent 8960 and the Spectrum Analyzer FSU26 via the divider. The band class is set as PCS band; Mobile Station was controlled to transmit Maximum power. Measure and record the Occupied Bandwidth of the Mobile Station by the Spectrum Analyzer FSU26

The OBW, that is the frequency bandwidth such that, below its lower and above its upper frequency limits, the mean powers radiated are each equal to 0.5 percent of the total mean power radiated by a given emission shall be measured under the following conditions as applicable:

Refer to 47CFR part2.1049 section (g)&(h).

(g) Transmitter in which the modulating base band comprises not more than three independent channels - when modulated by the full complement of signals for which the transmitter is rated. The level of modulation for each channel should be set to that prescribed in rule parts applicable to the

services for which the transmitter is intended. If specific modulation levels are not set forth in the rules, the tests should provide the manufacturer’s maximum rated condition.

(h) Transmitters employing digital modulation techniques - when modulated by an input signal such that its amplitude and symbol rate represent the maximum rated conditions under which the equipment will be operated. The signal shall be applied through any filter networks, pseudorandom generators or other devices required in normal service. Additionally, the occupied bandwidth shall be shown for operation with any devices used for modifying the spectrum when such devices are optional at discretion of the user.

Measurement bandwidth (RBW): 30 kHz (Resolution bandwidth)
 Video bandwidth (VBW): 300 kHz

Test Set-up

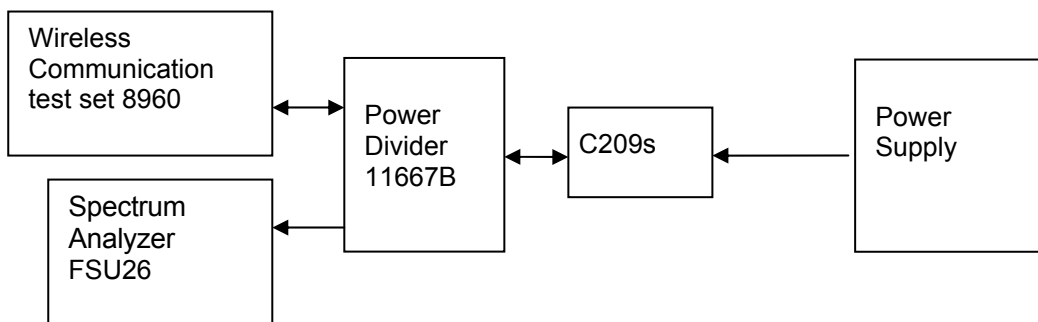

Figure 4. Test Set-up

6.4.4 Measurement Results

Table 28 Measurement Results

PCS Band		Occupied Bandwidth					
		Channel 25 (B) 1851.25MHz				Channel 1175(T) 1908.75MHz	
TEST CONDITIONS		Measured (MHz)				Measured (MHz)	
		TM1	TM3			TM1	TM3
T _{nom} (+25°C)	V _{nom} (3.7V)	1.2740	1.2740			1.2660	1.2660

6.4.5 Conclusion

The equipment **PASSED** the requirement of this clause.
 For the measurement results refer to appendix B.

6.5 Band Edges Compliance

6.5.1 Test Conditions

Table 29 Test Conditions

Preconditioning:	1 hour
Measured at:	Antenna connector
Ambient temperature:	24.5°C
Relative humidity:	53%
Test Configurations:	TM1 and TM3 at frequency B、 T

6.5.2 Test Specifications and Limits

6.5.2.1 Specification

CFR 47 (FCC) part 2.1051 and part 24.238

6.5.2.2 Supporting Standards

Table 30 Supporting Standards:

ANSI/TIA-603-C: 2004	Land Mobile FM or PM Communications Equipment Measurement and Performance Standards
ANSI/TIA-98-E: 2003	Recommended Minimum Performance Standards for cdma2000 Spread Spectrum Mobile Stations.

6.5.2.3 Limits

Compliance with 24.238, all spurious emission must be attenuated below the transmitter power by at least $43 + 10 \log_{10} P$. (Whereas P is the rated power of the EUT).

Table 31 Limits

Rated Power:	21.0dBm
Required attenuation:	$43 + 10 \log (0.125) = 34.0$, 21.0dBm – 34.0dB
Absolute level	- 13 dBm

6.5.3 Test Method and Setup

Mobile Station was connected to the wireless communication test set Agilent 8960 and the Spectrum Analyzer FSU26 via the divider, the band class is set as PCS band. Mobile Station was controlled to transmit Maximum power. Measure and record Band edge compliance of the Mobile Station by the FSU26.

Test Set-up

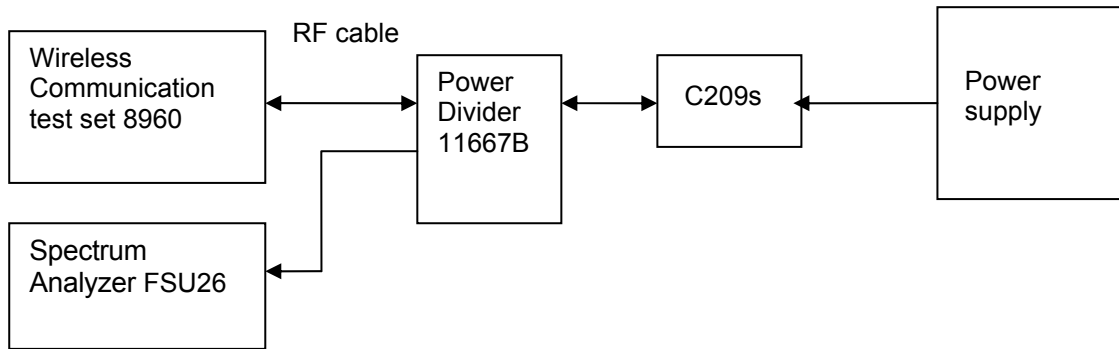

Figure 5. Test Set-up

6.5.4 Measurement Results at Band Edges

Table 32 Measurement Results outside Band Edges-- Single Carrier

Band	Frequency of Band edges [MHz]	Channel Number	Test Mode	Conducted Power [dBm]	Spurious Level measured [dBm]	FCC limit	Result
T_{nom} (25 °C), V_{nom} (3.7V)							
PCS Band	1850	25 (B)	TM1 & TM3	20.92	<-13(See appendix C)	- 13 dBm	Pass
	1910	1175 (T)	TM1 & TM3	20.88	<-13(See appendix C)	- 13 dBm	Pass

6.5.5 Conclusion

The equipment **PASSED** the requirement of this clause.
For the measurement results refer to appendix C.

6.6 Spurious Emission at Antenna Terminal

6.6.1 Test Conditions

Table 33 Test Conditions

Preconditioning:	1 hour
Measured at:	Antenna connector
Ambient temperature:	24°C
Relative humidity:	52 %
Test Configurations:	TM1 and TM3 at frequency B、 M、 T

6.6.2 Test Specifications and Limits

6.6.2.1 Specification

CFR 47 (FCC) part 2.1051 and part 24.238

6.6.2.2 Supporting Standards

Table 34 Supporting Standards:

ANSI/TIA-603-C: 2004	Land Mobile FM or PM Communications Equipment Measurement and Performance Standards
ANSI/TIA-98-E: 2003	Recommended Minimum Performance Standards for cdma2000 Spread Spectrum Mobile Stations. Release C

6.6.2.3 Limits

Compliance with part 24.238, all spurious emission must be attenuated below the transmitter power by at least $43 + 10 \log_{10} P$. (Whereas P is the rated power of the EUT).

Table 35 Limits

Rated Power:	21.0 dBm
Required attenuation:	$43 + 10 \log(0.125) = 34.0$, 21.0 dBm – 34.0 dB
Absolute level	- 13 dBm

6.6.3 Test Method and Setup

Mobile Station was connected to the wireless communication test set Agilent 8960 and the Spectrum Analyzer FSU26 via the divider, the band class is set as PCS band. Mobile Station was controlled to transmit Maximum power. Measure and record the Conducted Spurious Emission of the Mobile Station by the Spectrum Analyzer FSU26.

According to part 24.238, the defined measurement bandwidth as following:

24.238(b) Measurement procedure: Compliance with these rules is based on the use of measurement instrumentation employing a resolution bandwidth of 1000 kHz or greater.

Measurement bandwidth (RBW) for 9 kHz up to 150kHz: 1kHz;
 Measurement bandwidth (RBW) for 150kHz up to 30MHz: 10kHz;
 Measurement bandwidth (RBW) for 30MHz up to 3GHz: 1MHz;

Measurement bandwidth (RBW) for 3GHz up to 20GHz: 1MHz;

Test Set-up

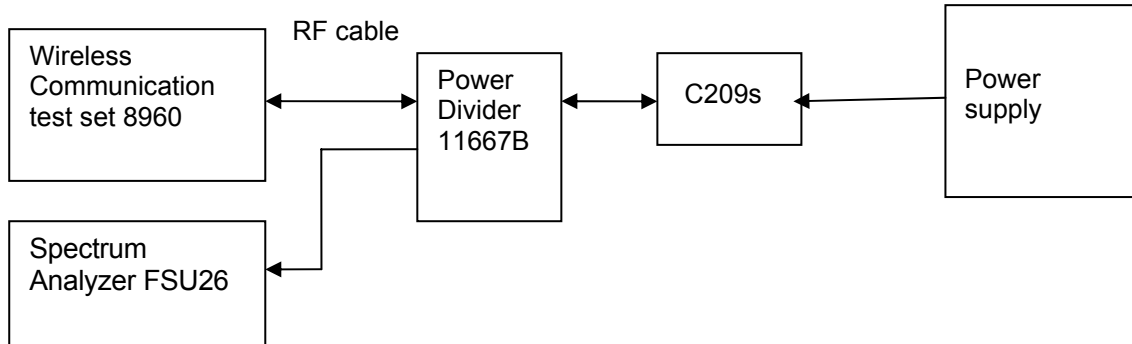

Figure 6. Test Set-up

6.6.4 Measurement Results at Conducted Spurious Emission

Table 36 Measurement Results

Channel Number	Test Mode	Test Range (Frequency)	Conducted Power [dBm]	Spurious Level measured [dBm]	FCC limit	Result
Channel 25(B)	TM1	9 kHz ~20GHz	20.85	<- 13 dBm (See appendix D)	- 13 dBm	Pass
	TM3	9 kHz ~20GHz	20.91	<- 13 dBm (See appendix D)	- 13 dBm	Pass
Channel 600(M)	TM1	9 kHz ~20GHz	20.87	<- 13 dBm (See appendix D)	- 13 dBm	Pass
	TM3	9 kHz ~20GHz	20.83	<- 13 dBm (See appendix D)	- 13 dBm	Pass
Channel 1175(T)	TM1	9 kHz ~20GHz	20.93	<- 13 dBm (See appendix D)	- 13 dBm	Pass
	TM3	9 kHz ~20GHz	20.98	<- 13 dBm (See appendix D)	- 13 dBm	Pass

6.6.5 Conclusion

The equipment **PASSED** the requirement of this clause. For the measurement results refer to appendix D.

6.7 Radiated Spurious Radiation

6.7.1 Test Conditions

Table 37 Test Conditions

Preconditioning:	1 hour
Measured at:	enclosure
Ambient temperature:	22 °C
Relative humidity:	53 %
Test Configurations:	TM1 at frequency M

6.7.2 Test Specifications and Limits

6.7.2.1 Specification

CFR 47 (FCC) part 2.1053 and part 24.238

6.7.2.2 Supporting Standards

Table 38 Supporting Standards:

ANSI/TIA-603-C: 2004	Land Mobile FM or PM Communications Equipment Measurement and Performance Standards
ANSI/TIA-98-E: 2003	Recommended Minimum Performance Standards for cdma2000 Spread Spectrum Mobile Stations.

6.7.2.3 Limits

Compliance with 24.238, all spurious emission must be attenuated below the transmitter power by at least $43 + 10 \log_{10} P$. (Whereas P is the rated power of the EUT).

Table 39 Limits

Rated Power:	21 dBm (0.125W)
Required attenuation:	$43 + 10 \log_{10} (0.125W) = 34$ dB
Absolute level	21 dBm – 34 dB = - 13 dBm

6.7.3 Test Method and Setup

(a) Measurements were made to detect spurious emissions radiated directly from the cabinet, control circuits, power leads, or intermediate circuit elements under normal conditions of installation and operation. Curves or equivalent data were supplied showing the magnitude of each harmonic and other spurious emission. For this test, single sideband, independent sideband, and controlled carrier transmitters shall be modulated under the conditions specified in paragraph 2.1049(c) as appropriate. For equipment operating on frequencies below 890 MHz, an Open Field Test is normally required with the measuring instrument antenna located in the far field at all test frequencies. In the event it is either impractical or impossible to make open field measurements (e.g. a broadcast transmitter installed in a building) measurement will be accepted of the equipment as installed. Such measurements must be accompanied by a description of the site where the measurements were made showing the location of

any possible source of reflections, which might distort the field strength measurements. Information submitted shall include the relative radiated power of each spurious emission with the reference to the rated power output of the transmitter, assuming all emissions are radiated from half-wave dipole antennas.

- (b) Measurements specified in paragraph (a) of this section shall be made for the following equipment:
- (1) Those in which the spurious emission are required to be 60 dB or more below the mean power of the transmitter.
 - (2) All equipment operating on frequencies higher than 25 MHz
 - (3) All equipment where the antenna is an integral part of, and attached directly to the transmitter.
 - (4) Other types of equipment as required, when deemed necessary by the Commission.

Huawei Mobile Station is equipment with non-integral antenna. And it should test according to part (b) of above section.

BTS simulator is connected to a communication antenna, by which communicates with the Handset inside the test site. The BTS simulator controls the Handset to transmit at maximum power which defined in specification of product when in traffic mode, The Handset operates on a typical channel.

The test procedure:

- (a) For transmitters other than single sideband, independent sideband and controlled carrier radiotelephone, E.R.P. shall be measured when the transmitter is adjusted in accordance with the tune-up procedure to give the values of current and voltage on the circuit elements specified in 2.1033(c)(8). Connect the Mobile Station to the BTS simulator via the air interface. The band class is set as PCS band.
- (b) Test the Radiated maximum output power by the Rohde and Schwarz ESMI Test Receiver from test antenna.
- (c) Use substitution method to verify the Maximum output power. The EUT is substituted by a dipole antenna. The dipole is connected to a signal generator. And then adjust the output level of the signal generator to get the same received power recorded in step (b) on ESMI Test Receiver, and record the power level of Signal Generator. Of course, the cable loss at the test frequency should be compensated.

According to part 24.238, the defined measurement bandwidth as following:

24.238 (b) Measurement procedure: Compliance with these rules is based on the use of measurement instrumentation employing a resolution bandwidth of 1000 kHz or greater.

Measurement bandwidth (RBW) for 9 kHz up to 1 GHz: 1MHz;
Measurement bandwidth (RBW) for 1GHz up to 26.5GHz: 1MHz;

Test setup

Step 1: Pre-test

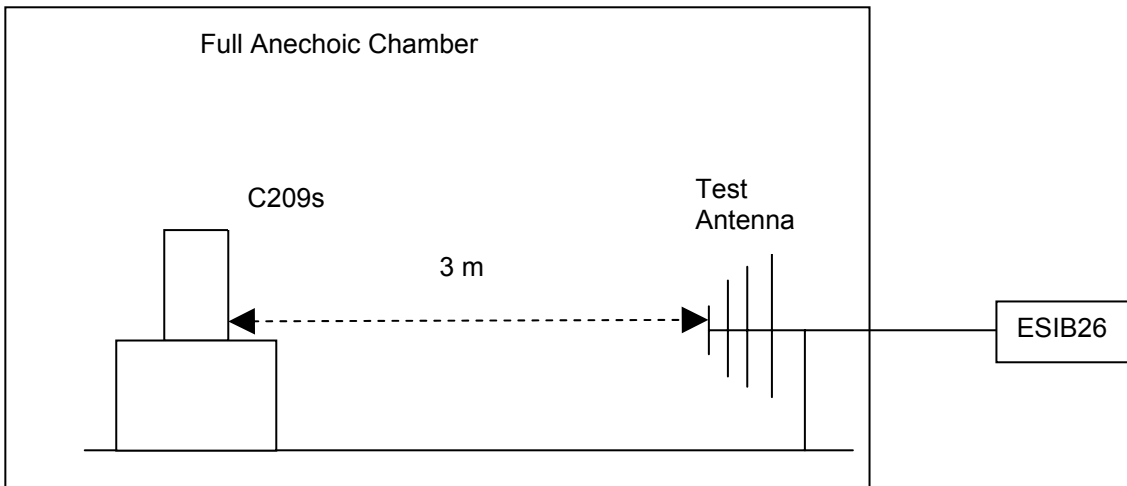

Step 2: Substitution method to verify the maximum ERP

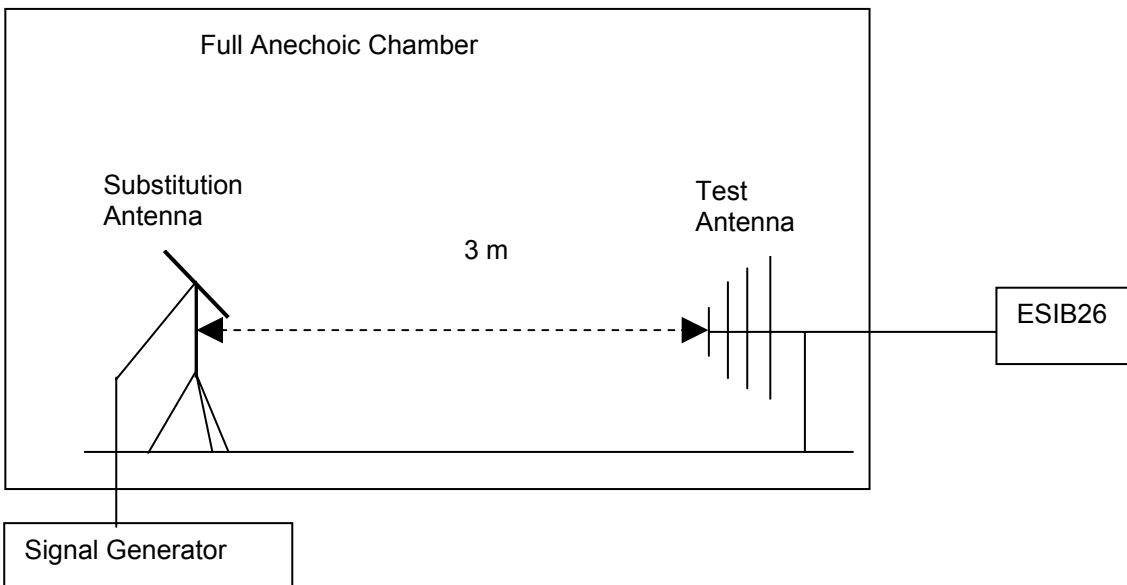

Figure 7. Test Set-up

NOTE: Effective radiated power (ERP) refers to the radiation power output of the EUT, assuming all emissions are radiated from half-wave dipole antennas.

6.7.4 Measurement Results

6.7.4.1 Pre-test Measurement Results

Table 40 Measurement Results

Channel Number	Test Range (Frequency)	Rated Power [dBm]	Spurious Level measured [dBm]	FCC limit	Result
600	9 kHz ~26.5GHz	21	<- 13 dBm (See appendix F)	- 13 dBm	Pass

6.7.4.2 Substitution Results

No peak found in pre- test. All frequency points' margin are bigger than 20dB, so the substitution method isn't used.

Calculation Sample:

Table 41 Substitution Results

Freq. [MHz]	Measurement Value [dBm]	Substitution Antenna Type	Gain [dBd]	Cable Loss [dB]	Signal Generator Level [dBm]	Substitution Level [dBm]	FCC limit [dBm]	Result

Note: For get the E.R.P. (Efficient Radiated Power) in substitution method, the following formula should take to calculate it,

$$E.R.P. [dBm] = SGP [dBm] - Cable Loss [dB] + Gain [dBd]$$

NOTE: SGP- Signal Generator Level

6.7.5 Conclusion

The equipment **PASSED** the requirement of this clause.
For the measurement results refer to appendix E.

6.8 Frequency Stability

6.8.1 Test Conditions

Table 42 Test Conditions

Preconditioning:	1 hour
Measured at:	Antenna connector
Ambient temperature:	See below
Relative humidity:	55% at 25°C
Test Configurations:	TM1 and TM3 at frequency M

6.8.2 Test Specifications and Limits

6.8.2.1 Specification

CFR 47 (FCC) part 2.1055 and part 24.235

6.8.2.2 Supporting Standards

Table 43 Supporting Standards:

ANSI/TIA-603-C: 2004	Land Mobile FM or PM Communications Equipment Measurement and Performance Standards
EIA/TIA-98E: 2003	Recommended Minimum Performance Standards for cdma2000 Spread Spectrum Mobile Stations.

6.8.2.3 Limits

No specific frequency stability requirement in part 2.1055 and part 24.235.

6.8.3 Test Method and Setup

The frequency stability shall be measured with variation of ambient temperature as follows:

- (1) From -30° to $+50^{\circ}$ centigrade for all equipment except that specified in subparagraphs
- (2) and (3) of paragraph 2.1055

(a) Frequency measurements shall be made at the extremes of the specified temperature range and at intervals of not more than 10° centigrade through the range. A period of time sufficient to stabilize all of the components of the oscillator circuit at each temperature level shall be allowed prior to frequency measurement. The short-term transient effects on the frequency of the transmitter due to keying (except for broadcast transmitters) and any heating element cycling normally occurring at each ambient temperature level also shall be shown. Only the portion or portions of the transmitter containing the frequency determining and stabilizing circuitry need be subjected to the temperature variation test.

(b) The frequency stability shall be measured with variation of primary supply voltage as follows:

- (1) Vary primary supply voltage from 85 to 115 percent of the nominal value for other than hand carried battery equipment.
- (2) For hand carried, battery powered equipment, reduce primary supply voltage to the battery operating end point, which shall be specified by the manufacturer.
- (3) The supply voltage shall be measured at the input to the cable normally provided with the equipment, or at the power supply terminals if cables are not normally provided. Effects on frequency of transmitter keying (except for broadcast transmitters) and any heating element cycling at the nominal supply voltage and at each extreme also shall be shown.

(c) When deemed necessary, the Commission may require tests of frequency stability under conditions

in addition to those specifically set out in paragraphs (a), (b), (c) of this section. (For example, measurements showing the effect of proximity to large metal objects, or of various types of antennas, may be required for portable equipment.)

The EUT can only work in such extreme voltage 3.5V and 4.2V , so here the EUT is tested in the 3.5V and 4.2V.

Test Set up

Connect the Mobile Station to the Wireless Communication test set 8960 via the connector. Then measure the frequency error by the Wireless Communication test set 8960. The Mobile Station's output is matched with a 50 Ω loads.

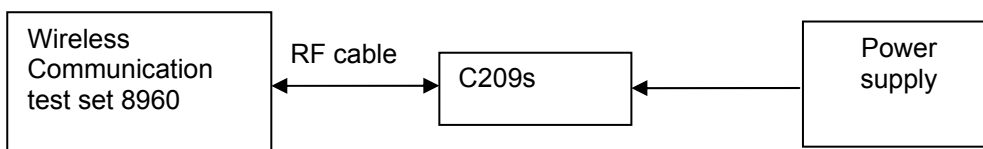

Figure 8. Test Set up

6.8.4 Measurement Results

6.8.4.1 Measurement Results vs. Variation of Temperature

- PCS, TM1, 3.7V DC Channel No.600(1880.00MHz)

Table 44 Measurement Results vs. Variation of Temperature—TM1

Temperature	Conducted Power (dBm)	Nominal Frequency (MHz)	Measured Frequency Error(Hz)	Result
-30 °C	20.81	1880.0	3	Pass
-20 °C	20.92	1880.0	8	Pass
-10 °C	20.96	1880.0	4	Pass
0 °C	20.85	1880.0	-4	Pass
+10 °C	20.94	1880.0	6	Pass
+20 °C	20.92	1880.0	-6	Pass
+30 °C	20.84	1880.0	2	Pass
+40 °C	20.91	1880.0	2	Pass
+50 °C	21.03	1880.0	-6	Pass

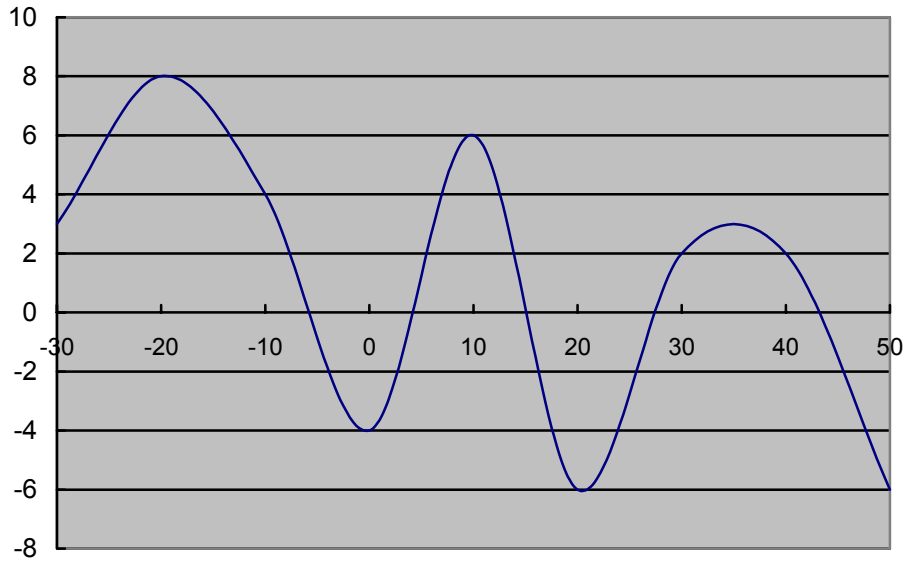

Figure 9. TM1 Test Graph

- PCS, TM3, 3.7V DC Channel No.600(1880.00MHz)

Table 45 Measurement Results vs. Variation of Temperature—TM3

Temperature	Conducted Power (dBm)	Nominal Frequency (MHz)	Measured Frequency Error(Hz)	Result
-30 °C	20.92	1880.0	-9	Pass
-20 °C	20.86	1880.0	-6	Pass
-10 °C	20.94	1880.0	5	Pass
0 °C	20.87	1880.0	-3	Pass
+10 °C	21.04	1880.0	11	Pass
+20 °C	20.81	1880.0	-4	Pass
+30 °C	21.10	1880.0	-3	Pass
+40 °C	20.85	1880.0	6	Pass
+50 °C	20.93	1880.0	9	Pass

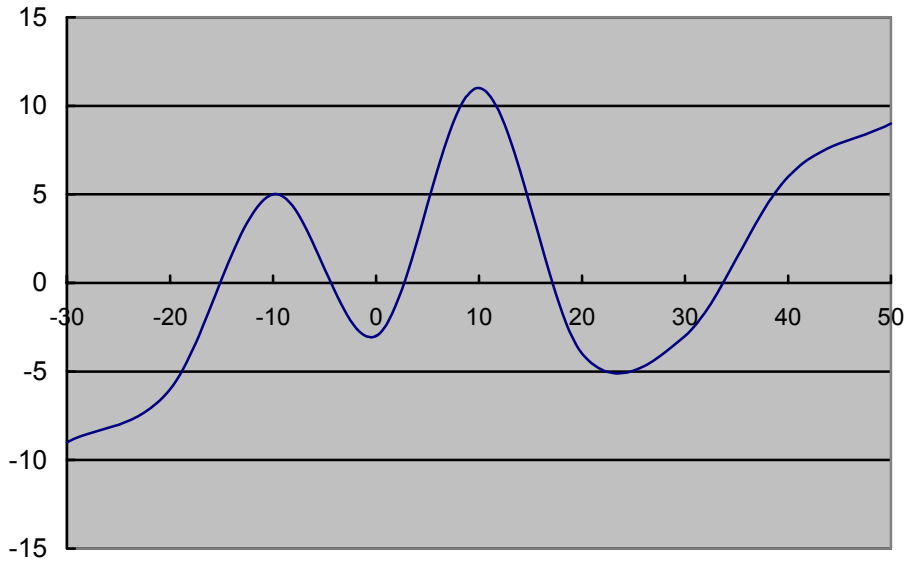

Figure 10. TM3 Test Graph

6.8.4.2 Measurement Results vs. Variation of Voltage

- **PCS, TM1, 25 °C ,Channel No. 600(1880.00MHz)**

Table 46 Measurement Results vs. Variation of Voltage - TM1

Voltage	Conducted Power (dBm)	Nominal Frequency (MHz)	Measured Frequency Error(Hz)	Result
3.4	20.93	1880.0	-8	Pass
3.7	21.02	1880.0	6	Pass
4.2	20.88	1880.0	-6	Pass

- **PCS, TM3, 25 °C ,Channel No. 600(1880.00MHz)**

Table 47 Measurement Results vs. Variation of Voltage - TM3

Voltage	Conducted Power (dBm)	Nominal Frequency (MHz)	Measured Frequency Error(Hz)	Result
3.4	21.05	1880.0	-6	Pass
3.7	20.91	1880.0	-7	Pass
4.2	21.02	1880.0	4	Pass

6.8.5 Conclusion

The equipment **PASSED** the requirement of this clause.

7 EMC Test

7.1 Conducted Emission at Power Port

7.1.1 Test Conditions

Table 48 Test Conditions

Preconditioning:	1 hour
Measured at:	Power port
Ambient temperature:	23.5°C
Relative humidity:	55 %
Test Configurations:	TM1 at frequency M

7.1.2 Test Specifications and Limits

7.1.2.1 Specification

CFR 47 (FCC) part 15.107

7.1.2.2 Supporting Standards

Table 49 Supporting Standards:

ANSI C63.4: 2003	Methods of Measurement of Radio-Noise Emissions from Low Voltage Electrical and Electronic Equipment in the Range of 9 kHz to 40 GHz
------------------	--------------------------------------------------------------------------------------------------------------------------------------

7.1.2.3 Limits

Compliance with part 15.107, conducted emission must meet the requirement of following table.

Table 50 Limits

Frequency of Emission (MHz)	Conducted Limit (dB μ V)	
	Quasi-peak	Average
0.15-0.5	66 to 56 *	56 to 46 *
0.5-5	56	46
5-30	60	50

Note: * Decreases with the logarithm of the frequency.

7.1.3 Test Method and Setup

The Table-top EUT was placed upon a non-metallic table 0.8 m above the horizontal metal reference ground plane. EUT was connected to LISN and LISN was connected to reference Ground Plane. EUT was 80cm from LISN. The set-up and test methods were according to ANSI C63.4: 2003.

Conducted Disturbance at AC Port measurements were undertaken on the L and N Lines. The emissions were measured using a Quasi-Peak Detector and Average Detector.

Huawei Mobile Station was communicated with the BTS simulator through Air interface, the BTS simulator controls the Mobile Station to transmitter the maximum power which defined in specification of product. The Mobile Station operated on the typical channel.

Measurement bandwidth (RBW) for 150kHz to 30 MHz: 9 kHz;

Test Set-up

The Mobile Station was setup in the screened chamber and operated under nominal conditions.

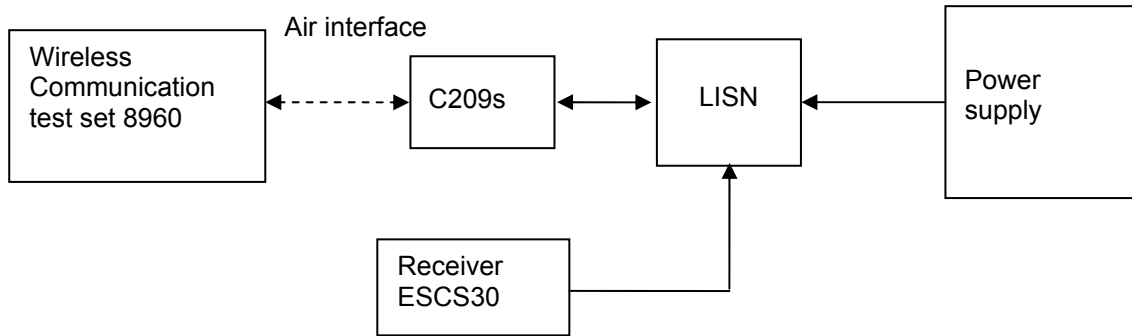

Figure 11. Test Set-up

7.1.4 Measurement Results

7.1.4.1 ADAPTER TPCA-053065E

Table 51 MEASUREMENT RESULT:QP DECTER

Frequency (MHz)	Level (dBμV)	Transd (dB)	Limit (dBμV)	Margin (dB)	Line	PE
0.181500	43.30	10.1	64	20.7	N	FLO
0.703500	42.60	10.0	56	13.4	L3	FLO
1.149000	42.00	10.1	56	14.0	L3	FLO
2.134500	42.90	10.1	56	13.1	L3	FLO
7.305000	36.00	10.1	60	24.0	L3	FLO
19.666500	39.90	10.3	60	20.1	N	FLO

Table 52 MEASUREMENT RESULT:AV DECTER

Frequency (MHz)	Level (dBμV)	Transd (dB)	Limit (dBμV)	Margin (dB)	Line	PE
0.186000	32.00	10.1	54	22.0	N	FLO
0.775500	29.60	10.0	46	16.4	L3	FLO
1.185000	28.50	10.1	46	17.5	L3	FLO
2.517000	30.60	10.1	46	15.4	L3	FLO
5.158500	25.50	10.1	50	24.5	L3	FLO
20.386500	27.30	10.3	50	22.7	N	FLO

7.1.4.2 ADAPTER XQLCHW03

Table 53 MEASUREMENT RESULT:QP DECTER

Frequency (MHz)	Level (dB μ V)	Transd (dB)	Limit (dB μ V)	Margin (dB)	Line	PE
0.316500	43.70	10.1	60	16.3	L3	FLO
0.694500	35.20	10.0	56	20.8	L3	FLO
1.936500	39.00	10.1	56	17.0	L3	FLO
2.143500	32.30	10.1	56	23.7	L3	FLO
5.293500	26.90	10.2	60	33.1	L3	FLO
20.071500	18.40	10.3	60	41.6	L3	FLO

Table 54 MEASUREMENT RESULT:AV DECTER

Frequency (MHz)	Level (dB μ V)	Transd (dB)	Limit (dB μ V)	Margin (dB)	Line	PE
0.316500	44.30	10.2	50	5.7	L3	FLO
0.555000	31.50	10.0	46	14.5	L3	FLO
1.590000	28.40	9.9	46	17.6	L3	FLO
3.633000	26.40	10.1	46	19.6	L3	FLO
9.766500	34.50	10.9	50	15.5	L3	FLO
12.921000	29.50	11.6	50	20.5	L3	FLO

7.1.5 Conclusion

The equipment **PASSED** the requirement of this clause.
For the measurement results refer to appendix F.

7.2 Radiated Emission of Enclosure in idle mode

7.2.1 Test Conditions

Table 55 Test Conditions

Preconditioning:	0.5 hour
Measured at:	enclosure
Ambient temperature:	25 °C
Relative humidity:	45 %
Test Configurations:	TM1 at frequency M

7.2.2 Test Specifications and Limits

7.2.2.1 Specification

CFR 47 (FCC) part 15.109

7.2.2.2 Supporting Standards

Table 56 Supporting Standards:

ANSI C63.4: 2003	Methods of Measurement of Radio-Noise Emissions from Low Voltage Electrical and Electronic Equipment in the Range of 9 kHz to 40 GHz
------------------	--------------------------------------------------------------------------------------------------------------------------------------

7.2.2.3 Limits

The Radiated Emission of enclosure of EUT should compliance with the requirement of part 15.109. The limit showed in following table.

Table 57 Limits

Frequency of Emission (MHz)	Radiated Limit	
	Unit(μ v/m)	Unit(dB μ V/m)
30-88	100	40
88-216	150	43.5
216-960	200	46
960-1000	500	54

7.2.3 Test Method and Setup

The test site semi-anechoic chamber has met the requirement of NSA tolerance 4dB according to the standards: ANSI C63.4 (2003). The test distance was 3m. The EUT was set-up on insulator 80cm above the Ground Plane. The set-up and test methods were according to ANSI C63.4. The Radiated Disturbance measurements were made using a Rohde and Schwarz ESMI Test Receiver and control software ES-K1.

A preliminary scan and a final scan of the emissions were made from 30 MHz to 1GHz by using test

script of software; the emissions were measured using a Quasi-Peak Detector. The maximal emission value was acquired by adjusting the antenna height, polarisation and turntable azimuth in accordance with the software setup. Normally, the height range of antenna was 1m to 4m, the azimuth range of turntable was 0°to 360°, The receive antenna has two polarizations V and H.

Huawei Mobile Station was communicated with the BTS simulator through Air interface. The Mobile Station operated on the typical channel and the Mobile Station worked in idle mode, transmitter was not work in this test.

Measurement bandwidth: 30 MHz – 1000 MHz: 120 k Hz

Test set up

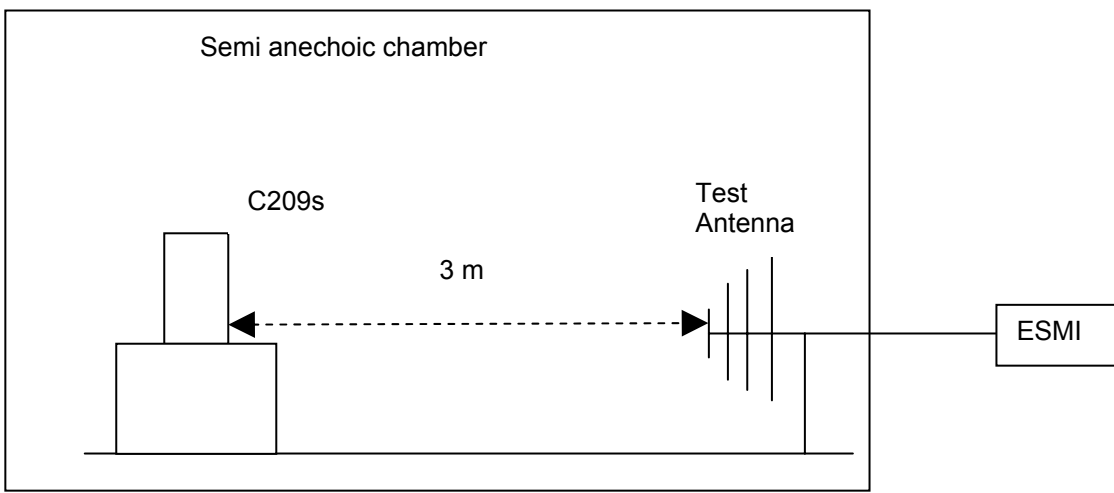

Figure 12. Test set up

7.2.4 Measurement Results

7.2.4.1 ADAPTER TPCA-053065E

Table 58 MEASUREMENT RESULT: QP DECTER

Frequency (MHz)	Level (dBμV/m)	Transd (dB)	Limit (dBμV/m)	Margin (dB)	Height (cm)	Azimuth (deg)	Polarisation
53.100000	27.40	-16.9	40.0	12.6	112.0	58.00	VERTICAL
53.460000	25.20	-17.0	40.0	14.8	128.0	67.00	VERTICAL
174.060000	21.50	-14.1	43.5	22.0	147.0	329.00	HORIZONTAL
192.420000	24.60	-14.2	43.5	18.9	156.0	340.00	HORIZONTAL
529.200000	23.10	-5.0	46.0	22.9	312.0	23.00	HORIZONTAL
973.680000	28.40	1.7	54.0	25.6	220.0	227.00	VERTICAL

7.2.4.2 ADAPTER XQLCHW03

Table 59 MEASUREMENT RESULT: QP DECTER

Frequency (MHz)	Level (dB μ V/m)	Transd (dB)	Limit (dB μ V/m)	Margin (dB)	Height (cm)	Azimuth (deg)	Polarisation
43.980000	31.00	-13.5	40.0	9.0	108.0	360.00	VERTICAL
55.680000	20.90	-17.6	40.0	19.1	190.0	32.00	VERTICAL
153.420000	21.10	-14.5	43.5	32.4	162.0	15.00	HORIZONTAL
252.180000	25.20	-10.8	46.0	10.8	100.0	360.00	HORIZONTAL
528.600000	23.00	-5.0	46.0	23.0	273.0	82.00	VERTICAL
959.400000	29.60	1.6	46.0	16.4	155.0	84.00	HORIZONTAL

7.2.5 Conclusion

The equipment **PASSED** the requirement of this clause.
For the measurement results refer to appendix G.

8 System Measurement Uncertainty

For a 95% confidence level, the measurement expanded uncertainties for defined systems, in accordance with the recommendations of ISO 17025 as following:

Table 60 System Measurement Uncertainty

Items		Extended Uncertainty
Effective Radiated Power of Transmitter	ERP(dBm)	U=3dB; k=2
Band Width	Magnitude (%)	U = 0.2%; k=2
Band Edge Compliance	Disturbance Power (dBm)	U = 2.0dB; k=2
Conducted Spurious Emission at Antenna Terminal	Disturbance Power (dBm)	U = 2.0dB; k=2
Frequency Stability	Frequency Accuracy(ppm)	U = 0.21ppm; k=2
Field Strength of Spurious Radiation	ERP(dBm)	U=2.2dB; k=2
Conducted Output Power	Power(dBm)	U=0.39dB; k=2
Conducted Emission at Power Port	Disturbance Voltage (dB μ V)	U=4dB; k=2
Radiated Emission of enclosure at idle mode	Field strength (dB μ V/m)	U=5dB; k=2

9 Appendixes

Appendix A	Measurement Results Modulation Characteristics	3 pages
Appendix B	Measurement Results Occupied Bandwidth	5 pages
Appendix C	Measurement Results Band Edges	5 pages
Appendix D	Measurement Results Spurious Emission at Antenna Terminal	25pages
Appendix E	Measurement Results Radiated Spurious Emission	5 pages
Appendix F	Measurement Results Conducted Emission at Power Port	3 pages
Appendix G	Measurement Results Radiated Emission of Enclosure at Ideal Mode	3 pages
Appendix H	Photos of Test Setup	6 pages