

The Comba logo is rendered in a blue, sans-serif font. The background of the page features a white document shape with a blue border and a large, stylized blue and purple geometric graphic on the right side.

COMFLEX NG MRU

MEDIUM POWER REMOTE UNIT

USER MANUAL

The information contained herein is confidential and the property of Comba and is supplied without liability for errors or omissions. No part may be reproduced, disclosed or used except as authorised by contract or other written permission. The copyright and the foregoing restriction on reproduction and use extend to all media in which the information may be embodied.

A large, stylized graphic on the right side of the page, composed of overlapping geometric shapes in shades of blue and purple, creating a sense of depth and modernity.

Table of Contents

1. OVERVIEW	1
1.1. APPEARANCE	1
1.2. NETWORK ARCHITECTURE	1
1.3. PHYSICAL PORTS AND INDICATION.....	2
2. TECHNICAL SPECIFICATION	4
2.1. FREQUENCY BANDS.....	4
2.2. RU GAIN	4
2.3. OUTPUT POWER.....	4
2.4. ELECTRICAL SPECIFICATION	5
2.4.1. <i>Input Power Voltage</i>	5
2.4.2. <i>Power Consumption</i>	5
2.5. MECHANICAL AND ENVIRONMENTAL.....	5
2.5.1. <i>Equipment size and weight</i>	5
2.5.2. <i>Environmental</i>	5
2.6. TRANSMISSION INTERFACE SPECIFICATION	5
3. INSTALLATION INSTRUCTIONS	6
3.1. PACKING LIST.....	6
3.2. . TOOL S REQUIREMENT	6
3.3. . INSTALLATIONS	7
3.3.1. <i>MRU Installation Step</i>	7
3.3.2. <i>Grounding</i>	9

Document History

Page No.	Version	Revised By	Details of Change
n/a	1-0-0	HaiLong Deng	First Release

List of Abbreviations

Abbreviation	Meaning
AC	Alternating Current
DC	Direct Current
ANT	Antenna
CLI	Command-Line Interface
GUI	Graphical User Interface
LED	Light-Emitting Diode
LMT	Local Maintenance Terminal
LTE	Long Term Evolution
NR	New Radio
PSU	Power Supply Unit
RF	Radio Frequency
Rx	Receive
Tx	Transmit
UL	Uplink
DL	Downlink

1. OVERVIEW

The ComFlex NG DAS system is an analog digital combination system that supports both wireless and direct access methods, and supports 4G and 5G standards. The wireless access method amplifies the RF signal by selecting the corresponding frequency band of the operator through digital signal processing, while the direct access method attenuates the RF signal through POI modules to ensure compatibility between the wireless and wired access sources. MU also converts radio frequency signals into optical signals, which are pulled far to the remote RU through optical fibers. RU amplifies the signal again and covers the network through Passive DAS.

1.1. APPEARANCE

The following figures shows the appearance of the Medium Power Remote.



Figure 1 Medium Power Remote Unit

1.2. NETWORK ARCHITECTURE

Following is the typical network architecture of ComFlex NG series Distributed Antenna System, Medium Power Remote is connected with the MU by optical fiber cable. The RF output of the RU is connected to antenna by RF cables. The MU and RU are powered by PSU in the equipment room or outdoor PSU.

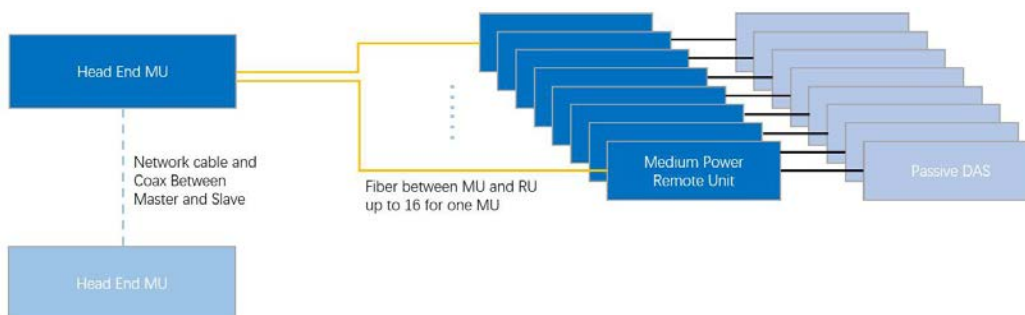

Figure 2 Medium Power Remote Network Diagram

1.3. PHYSICAL PORTS AND INDICATION

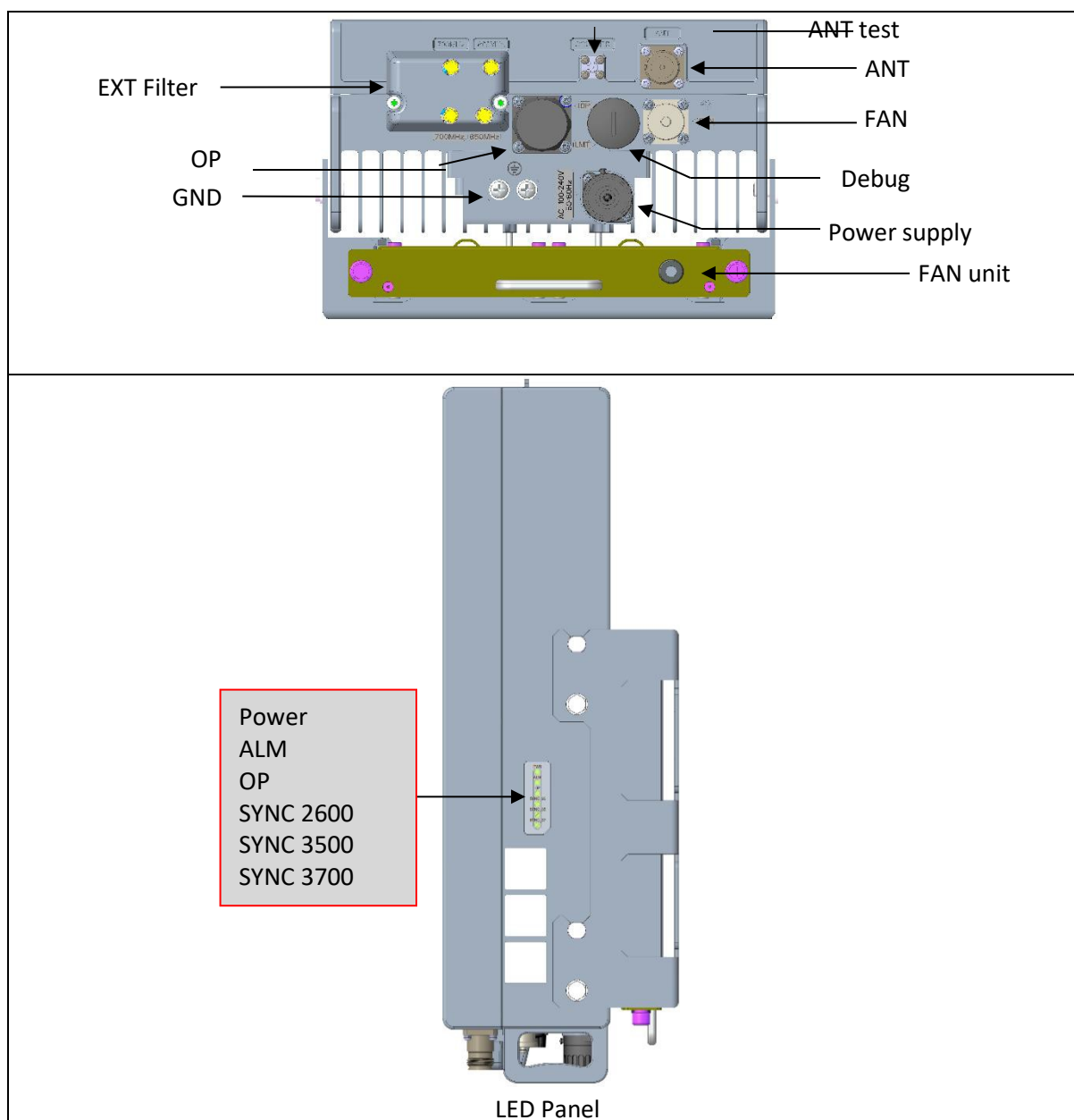

Figure 3 Port and Indication

Table 1 Ports at bottom side

Port	Connecter	Description
EXT filter	SMA	Connected ext 700/850MHz filter
OP	SC-APC	Connected optical fiber form MU
GND	M6 bolt	Connected GND wire
ANT test	SMA	Use for ANT port signal test
ANT	DIN4.3-10	Connected antenna
FAN	8pin-circle	Connected FAN unit
Debug	RJ45	Ethernet interface for LMT
Power supply	4pin-circle	Connected power supply

Table 2 LED indicator

LED Lable	Status	Description
PWR	Solid Green	Unit is powered ON and Operational
	Flashing Green	Unit is powered on and NOT Operational
	Off	Unit is not powered
ALM	Green	RU is NOT in alarm
	Red	RU is in alarm
OP	Green	Optical Link is established and operational
	Red	Optical Link is NOT established and operational
SYNC2600	Green	2600 TDD Sync established
	Off	2600 TDD Sync not established
SYNC3500	Green	3500 TDD Sync established
	Off	3500 TDD Sync not established
SYNC3700	Green	3700 TDD Sync established
	Off	3700 TDD Sync not established

2. TECHNICAL SPECIFICATION

2.1. FREQUENCY BANDS

Table 3 Medium Power Remote frequency bands

Band	TX Frequency (MHz)	RX Frequency (MHz)	IBW (MHz)
B12	728-746	698-716	18
B13	746-758	776-788	12
B14	758-768	788-798	10
B5	862-894	817-849	32
B66	2110-2200	1695-1780	90/85
B25	1930-2000	1850-1915	70/65
B41	2496-2690	2496-2690	194
N77	3450-3550	3450-3550	100
N77	3700-3980	3700-3980	280

2.2. RU GAIN

Table 4 Typical output power allocation

Band	TX Gain (dB)	RX Gain (dB)
B12	40	35
B13	40	35
B14	40	35
B5	40	35
B66	43	35
B25	43	35
B41	47	35
N77	47	35
N77	47	35

2.3. OUTPUT POWER

Table 5 Typical output power allocation

Band	TX Frequency (MHz)	Output power(dBm)
B12	728-746	30
B13	746-758	
B14	758-768	
B5	862-894	30
B66	2110-2200	33
B25	1930-2000	33
B41	2496-2690	37
N77	3450-3550	37
N77	3700-3980	37

2.4. ELECTRICAL SPECIFICATION

2.4.1. INPUT POWER VOLTAGE

Table 6 Input power voltage

Unit	Operation Voltage Range
MRU-78517192537-AC	100V to 240V AC
MRU-78517192537-DC	48V DC

2.4.2. POWER CONSUMPTION

Table 7 Power consumption

Mode	Output Power (W)	Typical Power Consumption (W)	Maximum Power Consumption (W)
Normal	21	160	190

2.5. MECHANICAL AND ENVIRONMENTAL

2.5.1. EQUIPMENT SIZE AND WEIGHT

Table 8 Equipment size and weight

Dimension (H x W x H)	Weight
480mm x 250mm x 130mm	15 kg (without mounting bracket)

2.5.2. ENVIRONMENTAL

Table 9 Equipment environment specification

Item	Specifications
Operation Temperature(°C)	-20 - +55
Operation Humidity	5 – 95%, non-condensing
Storage Temperature(°C)	-40 - +55
Environmental Protection	IP 30
Cooling	Convection (fans optional)

2.6. TRANSMISSION INTERFACE SPECIFICATION

Table 10 Fronthaul interface specification

Item	Specifications
Port Type	SC-APC
No. of Ports	1
Wave length (nm)	TX 1310+ RX 1550+WDM
Topology	Star
Maximum optical loss	8dBo

3. INSTALLATION INSTRUCTIONS

3.1. PACKING LIST

Table 11 Package list

NO	Description	Model	Quantity	Remarks
1	MRU	MRU-78517192537-AC / MRU-78517192537-DC	1 Pcs	





ACCESSORIES INCLUDED

NO	Description	Item code	Quantity	Remarks
1	GND Cable	6AWG,2m	1 Pcs	
3	Expansion bolt	M10x110	4 Pcs	
4	Mounting bracket 1	ADAS-S5100-5812	1 Pcs	
7	Screw	M6x16	4Pcs	
	FAN	MPRU-S5100	1 Pcs	

3.2. TOOLS REQUIREMENT

The requirement for the installation tools as follows:

Table 12 Tool Requirement

Tool Type	Usage
 Percussion drill	Drill the hole of $\Phi 14$ mm
 Open spanner	10 mm and 16 mm
 Hammer	Use to install the expansion bolt when use wall-mounted
 Cross screwdriver	$\phi 5$ mm
 Hexagon socket universal wrench	Use to open the window coverings and fix the mounting bracket

3.3. INSTALLATIONS

3.3.1. MRU INSTALLATION STEP

The Installation method of MRU is divided into wall-mount.

Step1: Remove the mounting rack from the MRU, use percussion drill to drill 4 pole of $\Phi 14$ with 65-75 mm depth, as shown in Figure 4.

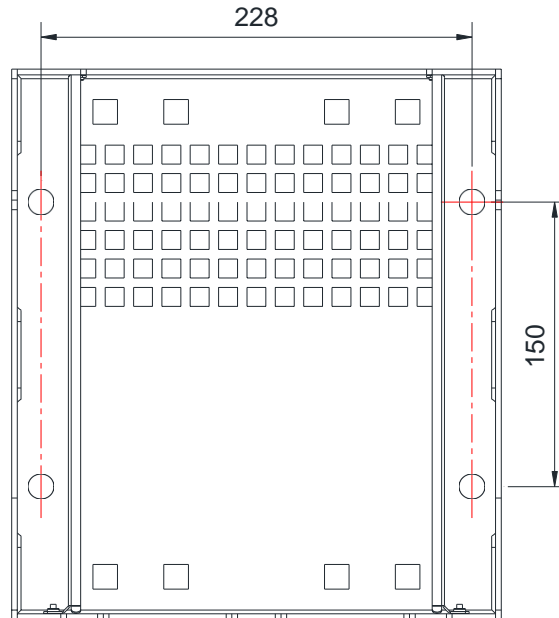

Figure 4 Wall-mounting Drilling Dimension Diagram

Step2: use hammer push 4 M10 expansion bolt into the hole of the wall, fix the mounting bracket (ADAS-S5100-5812) to the wall according the Figure 5.

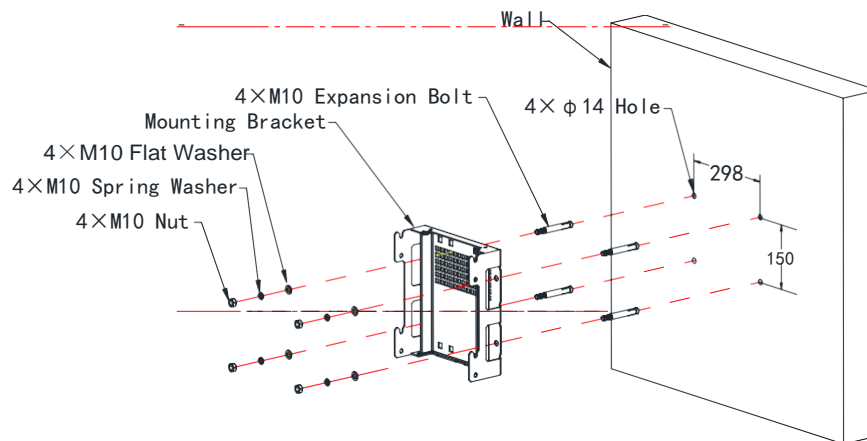

Figure 5 Mounting Bracket Installation Diagram

Step3: Lift the device, align the four mounting screws with the slot of the mounting tray, and tighten the four M8 screws on the left and right sides to secure the device, as shown in Figure 6.

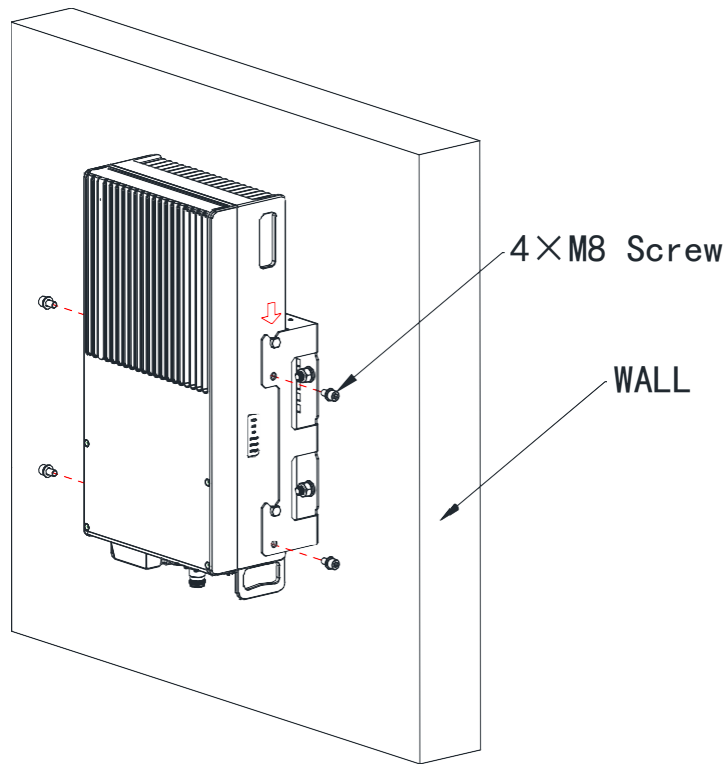

Figure 6 Wall Mounting (without Splitter)

If need the Splitter, please use RF Cable to connect the TX port of MRU to the COM port of splitter, as shown in Figure 7.

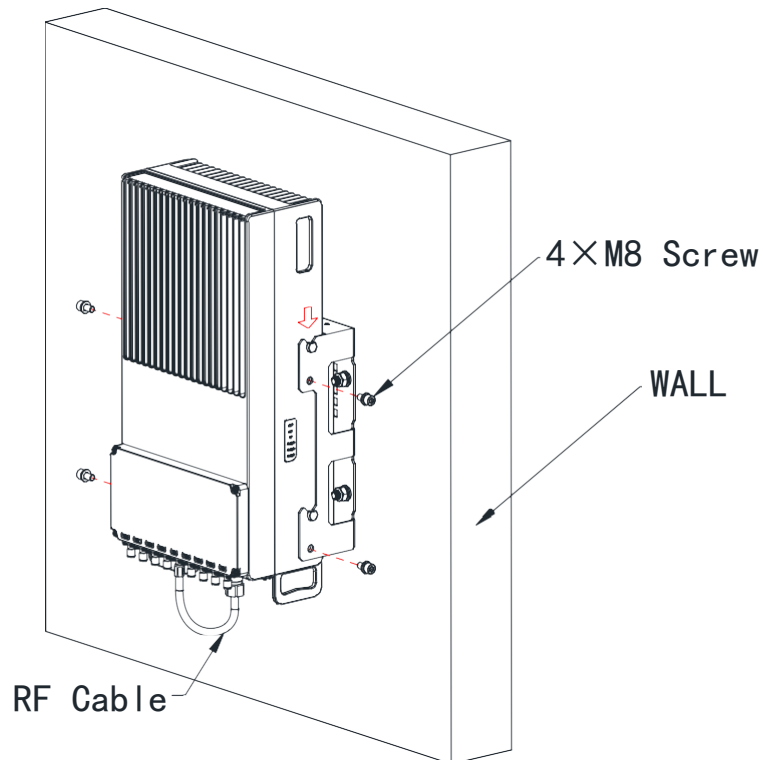

Figure 7 Wall Mounting (with Splitter)

If need the FAN, please insert the fan into the guide rail of the bracket and lock it with two M5 screws, and then connect the plug of the fan to the fan socket of the MRU, as shown in Figure 8.

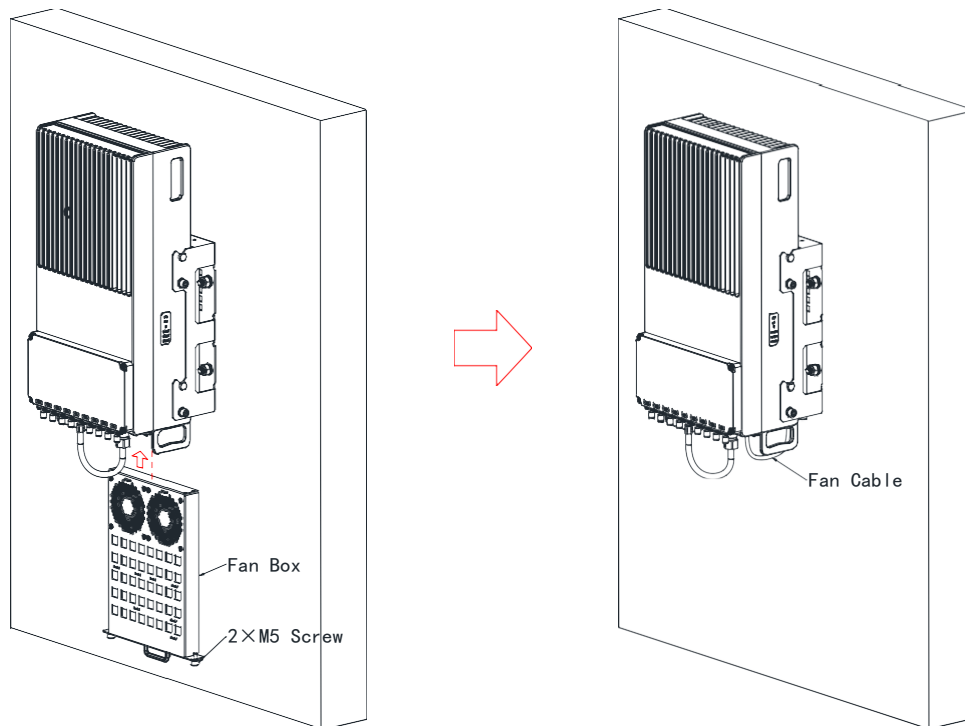

Figure 8 Fan Installation

3.3.2. GROUNDING

The Grounding cable is provided with the screw which will be installed at the chassis as shown in Figure 9.

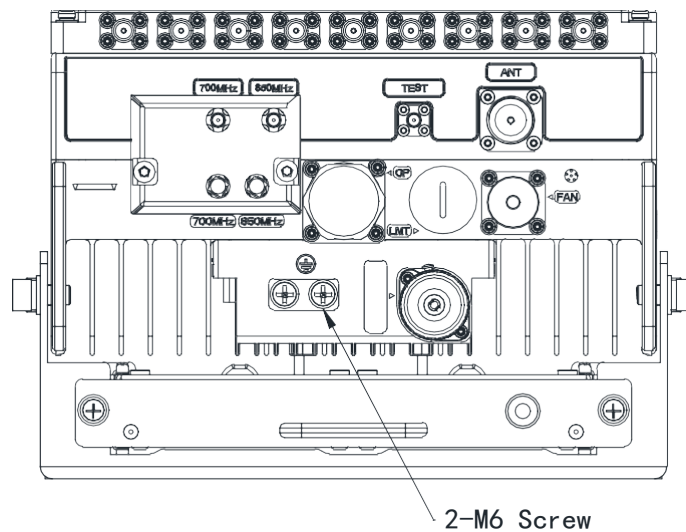

Figure 9 Grounding Cable Diagram

--End--

Part 20 and part 90 signal booster, this is a 90.219 class B device.

WARNING! This is NOT a CONSUMER device. It is designed for installation by FCC LICENSEES and QUALIFIED INSTALLERS. You MUST have an FCC LICENSE or express consent of an FCC Licensee to operate this device. You must register part 90 Class B signal boosters (as defined in 47 CFR 90.219) online at www.fcc.gov/signal-boosters/registration. Unauthorized use may result in significant forfeiture penalties, including penalties in excess of \$100,000 for each continuing violation.

Note: The grantee is not responsible for any changes or modifications not expressly approved by the party responsible for compliance. Such modifications could void the user's authority to operate the equipment.

WARNING!

Use only authorized and approved antennas, cables and/or coupling devices! The use of unapproved antennas, cables or coupling devices could cause damage and may be of violation of FCC regulations. The use of unapproved antennas, cables and/or coupling devices is illegal under FCC regulations and may subject the user to fines.

Any installation, adjustment, maintenance and repair of the equipment must only be carried out by trained, authorized personnel. At all times, personnel must comply with any safety notices and instructions. The design of the antenna installation needs to be implemented in such a way so as to ensure RF radiation safety levels and non-environmental pollution during operation.

Note: Antennas, feeders and couplers are not included in the packing list; solution provider should consider these accessories according to site conditions.

WARNING! Antenna gain should not exceed **5dBi**

To comply with FCC RF exposure compliance requirements, each individual antenna used for this transmitter must be installed to provide a separation distance greater than **3.2m** or more from all persons during normal operation and must not be co-located with any other antenna for meeting RF exposure requirements.

Contact information, i.e., licensee for Class B devices at (<https://signalboosters.fcc.gov/signal-boosters/>).