

Introduction of WS-2000/4000

- (1) Simple & refined design for the use in the office and a house.
- (2) Basically designed for the desktop, this can be installed in any place thanks to the wall mount bracket.
- (3) Clear and high voice quality (8Kbps / 13 Kbps QCELP, 8Kbps EVRC)
- (4) A user can easily adjust the volume of the handset with the volume control, and set the volume at the optimal level.
- (5) With a built-in back-up battery, you will stay on the call without a power failure.
- (6) LCD visually indicates the status of the terminal.
- (7) Outgoing Lock function can control who can access and use the terminal.
- (8) Simple and quick transmission of the stored number in the phone book with One-Touch and Two-Touch Dial.
- (9) The Hotline Call function allows the most frequently used number to be connected when a user picks up the handset.
- (10) This terminal provides the user-friendly multi-functional service like Alarm, DND, Alert Beep per 1 minute, Storing a memo during the conversation and so on.
- (11) Various warning tone and sound indicate the low battery and the incorrect use of the terminal.
- (12) Various supplementary services such as Three-way calling, Call waiting, Call transfer and Call forwarding are supported by being interfaced with the system (System dependent)
- (13) Packet, Circuit and PC fax communication are provided with a connection to a PC.
- (14) The Voice Privacy function prevents the illegal wiretapping.
- (15) The Authentication Key function prevents the owner's phone number from being cloned by others.
- (16) Calling Line Identification function (CLIP) is provided. (System dependent)
- (17) A simple and convenient menu ensures the easy installation of the terminal.

- (18) Thanks to a Full Duplex Speaker Phone, a user can converse with Echo-Free.
- (19) Being a system dependent, this terminal transmits DTMF for ARS connection.
- (20) This terminal supports High Speed Packet Data by using MSM 5000 family chip.

1. Installation

Thank you for purchasing this product. Please check whether the product package contains the following items. If there are items missing, please contact the store where the unit was purchased.

Phone



Power Supply(SMPS)

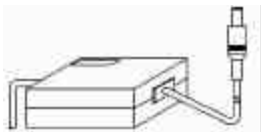

Antenna



Manual



Power Cord



1.1 Installation Procedure

- ? Connect the DC jack to the back panel of the phone as shown in the figure below.

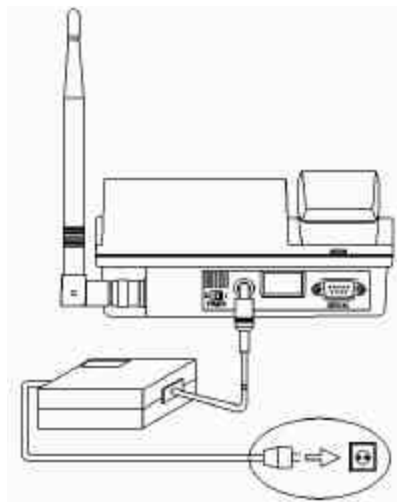
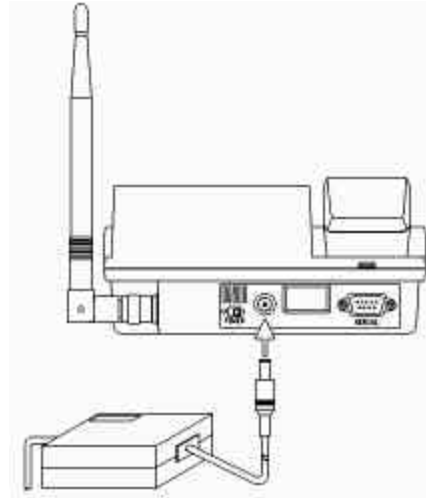

- ? Connect the plug of the SMPS to a power outlet and to SMPS for the phone.

- ? Turn power on by moving the switch button to the right as shown in the following figure. The power-up sound indicates the phone is initialized.

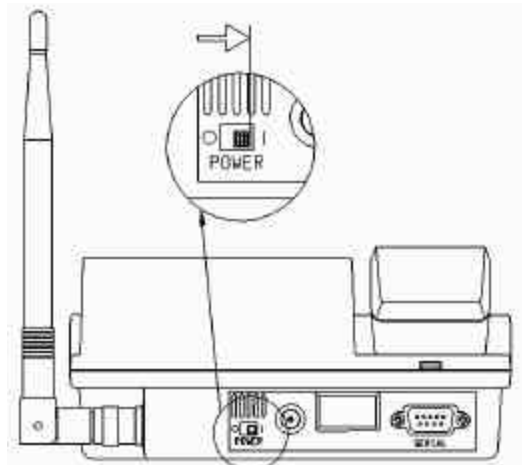

- ? Adjust the antenna direction until the maximum Antenna power sign is displayed on the LCD screen.
(Each bar indicates the received signal strength. More bars indicate higher signal strength and a better service condition.)

? See 2.1 Power-Up / Power-Down

1.2 Installing the Wall Bracket (Optional)

Before finalizing the precise location of the phone, please perform the signal strength test to ensure the best operating condition location for the assembled unit.

- ? For installing the unit into a concrete wall, make 3mm holes with a drill at the marked location and attach the Installation Panel. When installing mounting screws, do not screw them in all the way. Leave a 2mm space between the screw head and the installed panel.

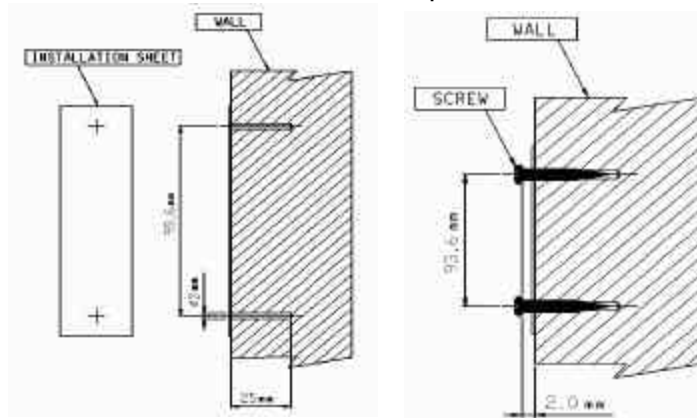

- ? On the bottom of the phone, please find the wall mounting slots(A1 ~A4). Install A1 and A2 onto the top screws. Push the wall mounting slots A3 and A4 onto the bottom screws until the phone is securely seated.

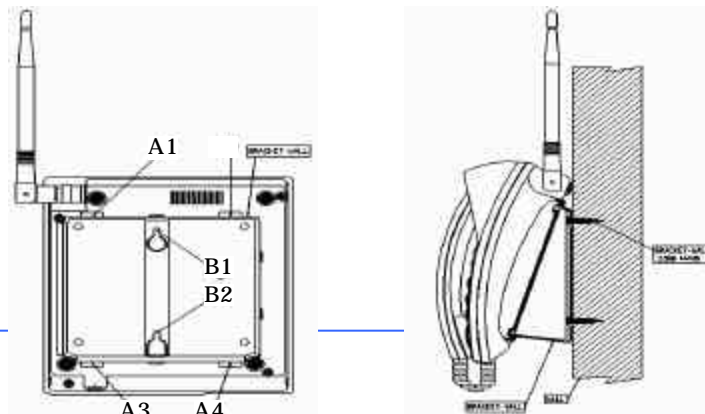

1.3 Phone Description

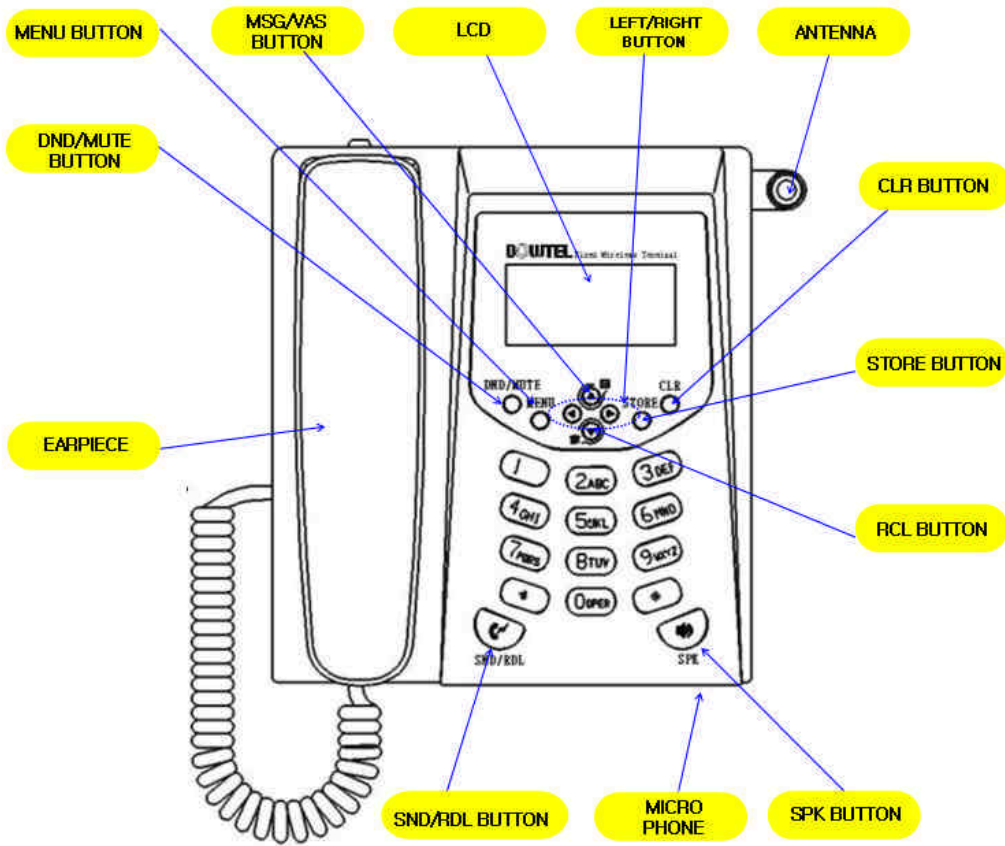

(Figure 1.2 – 1)

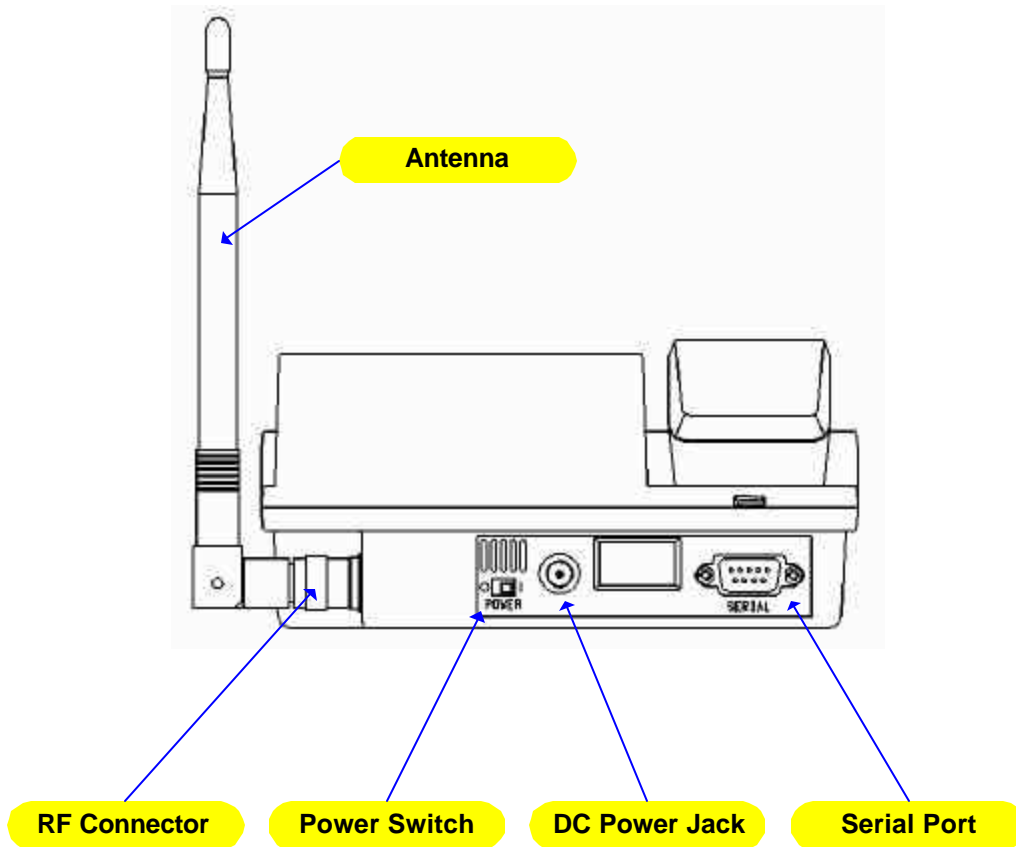

(Figure 1.2-2)

1.4 Safety Instructions

Basic safety precautions should always be followed to reduce the risk when using this unit.

- Read and follow all instructions marked on the product.
- To reduce the risk of electric shock, do not disassemble this unit. When the unit is subsequently used, incorrect reassembly can cause electric shock. When service is required, take the unit to an authorized service center.
- Do not hold or make contact with the antenna while making a call.
- Do not overload the wall outlets and the extension cord.
- Do not use this product near the water and never spill any liquid on the unit. This may result in the risk of fire or electric shock.
- Do not place this product on an unstable location (cart, stand or table). If this product should fall from an unstable location, the result may be risk of serious damage.
- Do not cover the slots and openings on the unit. They are provided for ventilation and protection against overheating. Do not place this product near the heater or radiator where proper ventilation is not provided.
- This product should only be operated from the type of power source marked on the product. If you are not sure of the type of power available, consult your dealer or local power company.
- Never push objects of any kind into this product, since this may result in a serious voltage short and may result in the risk of fire or electric shock.
- During thunderstorms, avoid using this product. There may be a remote risk of an electric shock from lighting.
- Unplug this product from the wall outlets and obtain service from an authorized service center under the following conditions:
 - When the power supply plug is damaged or frayed.
 - If liquid has been spilled into this product.
 - If this product has been exposed to water or rain.
 - If this product does not work properly when the operating instructions are followed.
 - If this product has been dropped or damaged.

- If this product exhibits a distinct change in performance.

2. Before Using Your Phone

2.1 Power-Up / Power-Down

2.1.1 General Power-Up

? Manufacturer's logo will be displayed for 1 second when the power is turned on.



(Figure 2.1.1-1)

? The screen (Figure 2.1.1-2) will be displayed with the power-up sound.

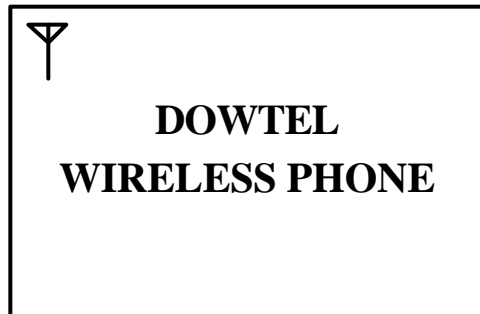

(Figure 2.1.1-2)

? If the phone receives the signal from the Service Provider, the screen displays the default date and time set by the factory. (Figure 2.1.1-3)

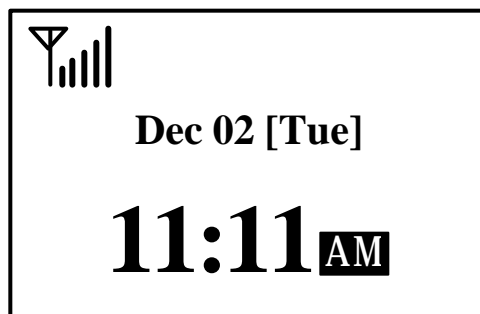

(Figure 2.1.1-3)

2.1.2 No Service

If the “No Service” message appears as illustrated in Figure 2.1.2, the location where the phone is installed may be an area where the signal from the Service Provider is not being delivered to the phone.

If the number of bars beside the Ant. symbol on the screen (Figure 2,1,1-3) is small, the received signal strength is weak. < Reference 2.3.1 RSSI Icon>

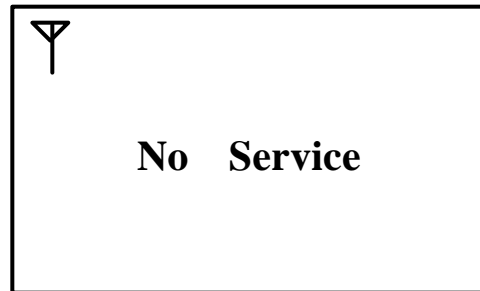

(Figure 2.1.2)

In this case, adjust the direction of the antenna until the maximum possible number of bars is displayed.

If a condition continues, as illustrated in Figure 2.1.2, or the maximum possible number of bars remains few despite changing the direction of the antenna, please contact the service center.

2.1.3 Registration Required

If the “Registration Required” message appears (Figure 2.1.3), this phone has not been registered to the Service Provider.

In this case, contact the Service Provider immediately.

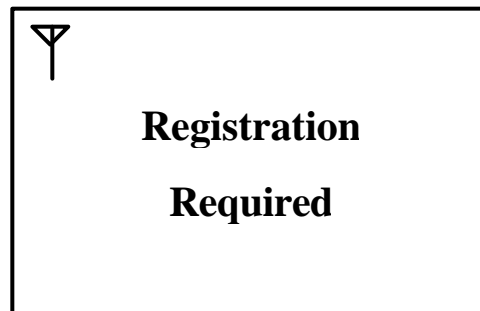

(Figure 2.1.3)

2.1.4 Power

Two types of power are used in this phone.

- AC power : 90 ~ 400 V
- Internal Battery

If the AC power is suddenly disconnected to the phone by a power failure, or for any other reason, the power source is automatically changed from AC power to the internal battery. When the power switch is in ON status and even though AC power is disconnected, this terminal will remain on operation.

To disconnect all power from the phone, whether internal or external, the power switch must be in the OFF position.

2.2 Keypad

As shown in the figure below, there are 12-Dial Buttons and 10-Function Buttons in this phone.

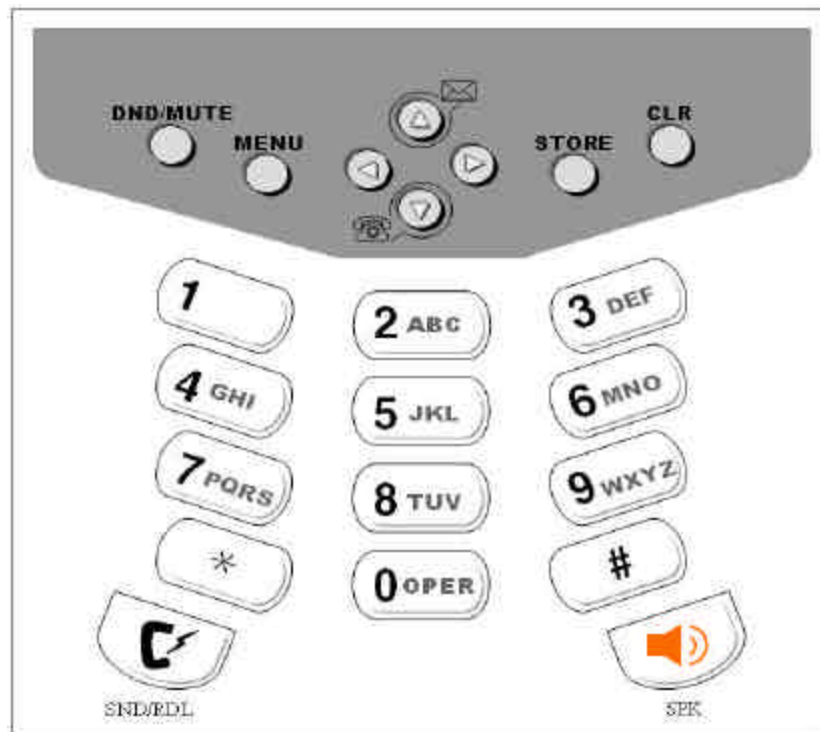

(Figure 2.2.1)

2.2.1 DND/MUTE

DND/MUTE



DND/MUTE

- Use this button to set the [DND(Do Not Disturb)] function to the on/off position. The DND function prohibits incoming calls when the phone is in the idle-state. (Reference 3.8)
- Use this button to set the [MUTE] function to the on/off position. The Mute function prohibits all sound from being transmitted to the calling party through the handset or microphone during a conversation.

2.2.2 RCL



RCL

Use this button to find the last dialed phone number and to search the stored numbers in the Phone Book.

To go sub-menu, press [MENU], select the icon and press this button.

2.2.3 MENU



Use this button to set the [MENU] mode or return to the Idle-state.

2.2.4 LEFT / RIGHT



Use this button to set the [MENU] mode, adjust the ringer and voice volume, and store/find phone numbers in the Phone Book.

2.2.5 STORE



Use this button to store the Phone Numbers and setting-value under the [MENU] mode.

2.2.6 MSG/VAS

**MSG/VAS**

- Use this button to retrieve text messages from the SMS (**S**hort **M**essage **S**ervice) transmitted and received during the idle-state.
- Use this button to make a call to the VMC (**V**oice **M**essage **C**enter) to retrieve voice mail after picking up the handset or turning on the speakerphone.
- To go sub-menu, press [MENU], select the icon and press this button.

2.2.7 CLR (Clear)**CLR**

Use this button to erase an incorrectly dialed number or to erase a number incorrectly entered into the Phone Book

2.2.8 SPEAKER [SPK]

Use this button to make or receive a call using the speakerphone.

2.2.9 SEND & REDIAL [SND/RDL]

**SND/RDL**

Use this button to send a dialed number when a call is placed and/or to redial and send the last number dialed.

2.2.8 Dial Button (0~9, * , #)

- Use this button to store a phone number
- There are small alphabetical characters beside the numeric numbers on each Dial Button. The alphabetical characters are provided to enable the user to store an alphabetical name that relates to the stored phone number.

<Example for use>

To store the name "DOWTEL3", use the following procedure:

<u>3</u>	<u>6</u>	<u>6</u>	<u>6</u>	<u>9</u>	<u>8</u>	<u>3</u>	<u>3</u>	<u>5</u>	<u>5</u>	<u>5</u>	<u>3</u>	<u>3</u>	<u>3</u>	<u>3</u>	<u>?</u>	[STORE]
D	O	W	T	E	L											3

As shown in the example above, the output alphabetical character is serially displayed on the LCD screen when the button is repeatedly pressed.

<Note>

You can store the name not only with uppercase character but also with lowercase character. The default mode is set to the uppercase character. Press [RCL] button when you want to change the mode and vice versa.

2.3 ICONS

Various icons are displayed on the first line of the LCD screen to indicate the

setting-status and operating-status of the phone.

2.3.1 RSSI Icon



- Indicates the received signal strength and relates to the quality of service.
- There are 5 bars displayed in graduated lengths. Five bars displayed next to the Antenna Symbol indicate the best signal strength and quality of service.
- Where only 1-bar exists, a poor signal strength and/or service condition exists. If a condition exists displaying a flashing Antenna icon, the phone is capable of only marginally dependable phone operation, and the phone is in danger of being disconnected.
- When there are no bars displayed on the screen, a call may not be placed or received and this condition indicates no signal is being received from the service provider in the user's area.

2.3.2 Connecting Icon



- Appears after the [SND/RDL] button has been activated, indicating the phone is processing a call

2.3.3 Off-Hook Icon



- Off Hook-Switch mode
- Displayed when the handset is picked up from the receiver.

2.3.4 Speaker Phone Icon



- Indicates the phone is in the Speaker Phone Mode.
- Displayed when a call is made using the speaker and microphone.

2.3.5 Voice Mute Icon.



- Indicates the status that the user's voice, any surrounding sounds, and keypad tone are not transmitted to the calling party.
- When this function is set during a conversation, no sound will be transmitted to the calling party.

2.3.6 PC Fax Receive Mode Icon



- Indicates the status that the phone is set in PC Fax Receive Mode to receive the facsimile transmission using data service.
- "Fax Rcv Mode" message is displayed on the bottom of the screen with this icon.
- If a call is received, the Fax Utility connected with the phone in the PC is automatically activated and the facsimile is received. The user will be unable to speak through the handset or speakerphone while the facsimile is being received.
- The user cannot receive the voice call from the other party when this mode is set and only can receive the facsimile. However, the user can make a voice call to the other party even if this mode is set unless the

facsimile is being received.

2.3.7 Modem Receive Mode Icon



- Indicates the status that the phone is set in Modem Receive Mode to transmit/receive the file using data service.
- “Modem Rcv Mode” message is displayed on the bottom line of the screen with this icon.
- If a call is received, the Communication Utility connected with the phone in the PC is automatically activated and the file is received. The user will be unable to speak through the handset or speakerphone while the facsimile is being received.
- The user cannot receive the voice call from the other party when this mode is set and only can receive the data files. However, the user can make a voice call to the other party even if this mode is set unless the data file is being received.

2.3.8 Battery Icon



- Indicates the strength of the installed, internal battery
- The battery strength is displayed in a range of 5-bars (strongest charge) to 0-bars (no charge).
- When the battery strength is weakening, the phone beeps to indicate a battery recharge is needed.

2.3.9 DND (Do Not Disturb) Icon



- Indicates the status the DND (Do Not Disturb) function has been set. This status will not allow any incoming calls.
- The icon will flash when activated.

2.3.10 Message Icon



- Indicates the status that the phone has received a Text Message and/or Voice Message.
- When the message is received, this icon is displayed on the screen and an accompanying tone will sound.
- The received message may be read and the voice mail may be retrieved through the Voice Mail Center (VMC) in the system using the [MSG/VAS] button.

2.3.11 Alarm Icon



- ? This icon comes on when the Alarm function is set. If this icon is displayed, the Alarm works at the specified time.

2.3.12 Upper Case Icon



- ? This icon shows all characters will be written in Upper Case when inputting a Text message and storing a phone books or memorizing.

2.3.13 Lower Case Icon



- ? This icon shows all characters will be written in Lower Case when inputting a Text message and storing a phone books or memorizing.

2.4 Sound & Tone

2.4.1 Power-Up Sound

When the phone's power is turned on, a beep-sound is transmitted.

2.4.2 Dial Tone

This sound indicates that the phone is able to connect with the system and a call may be made or received.

2.4.3 Warning Tone

When the phone is unable to connect with the system or the handset is incorrectly placed on the receiver, a tone is emitted through the handset or speaker.

2.4.4 Howler Tone

If the same situation, the connection failure of the phone with the system and the misplacement of the handset, continues after the Warning Tone, a much louder tone will sound for 30 seconds through the speaker.

2.4.5 Keypad Tone

When the keypad is pressed, a tone will be emitted through the speaker or handset.

2.4.6 Ring Sound

When a call is being received, a beep will be emitted through the speaker.

2.4.7 Alert Beep per 1 min

When a call is placed, there will be an alert beep every 1minute during the conversation.

2.4.8 Low Battery Warning Tone

When the phone is relying on the internal battery for power and the battery strength is weak, a low battery warning tone will sound through the speaker.

2.4.9 SMS/VMS Notification Tone

A SMS/VMS notification tone will sound through the speaker when the phone has received a SMS or VMS message.

2.4.10 Error Beep Tone

An Error Beep Tone will sound when the keypad is pressed incorrectly. In this case, the incorrect operation is ignored.

3. Basic Function

3.1 Making Calls

3.1.1 Using the Handset

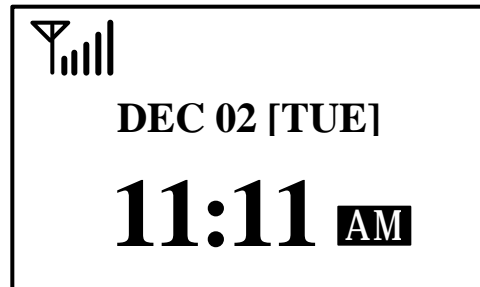
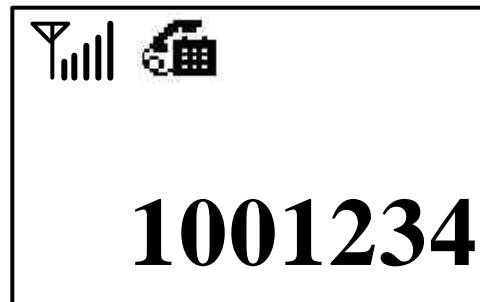

Figure 3.1.1-1)

? To place a call, lift the handset from the receiver and dial the desired phone number.



(Figure 3.1.1-2)

? Press the [SND/RDL] button.

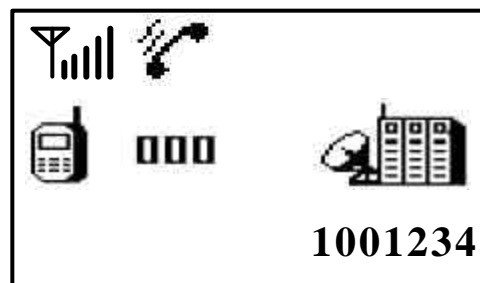

(Figure 3.1.1-3)

? The call is connected.

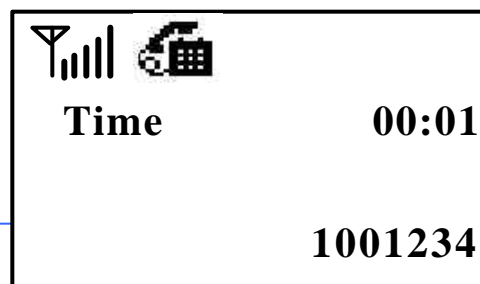

(Figure 3.1.1-4)

3.1.2 Using the Speaker Phone

? To place a call using the speaker phone, press the [SPK] button and dial the desired phone number.

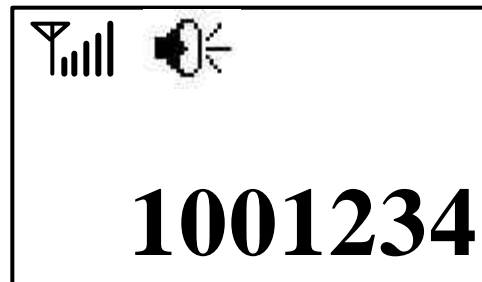

(Figure 3.1.2-1)

? Press the [SND/RDL] button.

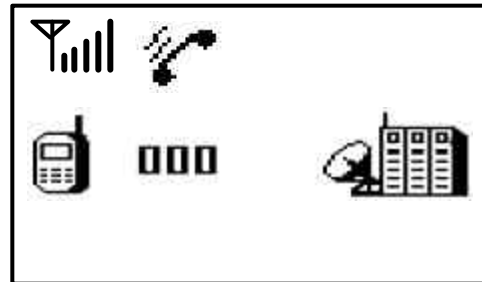

(Figure 3.1.2-2)

? The call is connected.

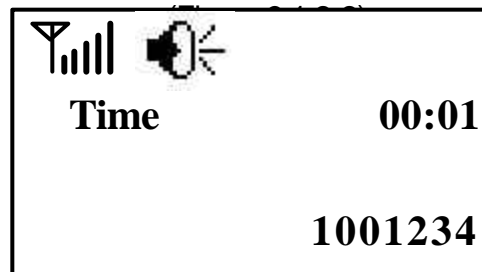

(Figure 3.1.2-3)

3.1.3 On-Hook Dialing

? Dial the phone number, and then press the [SND/RDL] button.

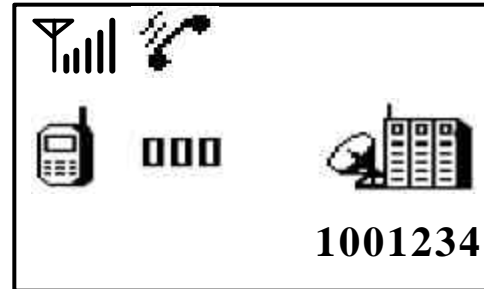

(Figure 3.1.3-1)

? The speaker phone operates automatically, connecting the call.

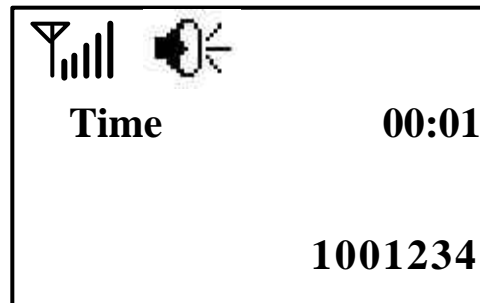

(Figure 3.1.3-2)

3.1.4 Redial the Last Number Called

<Method 1>

? Pick up the handset or press the [SPK] button, followed by the [SND/RDL] button.

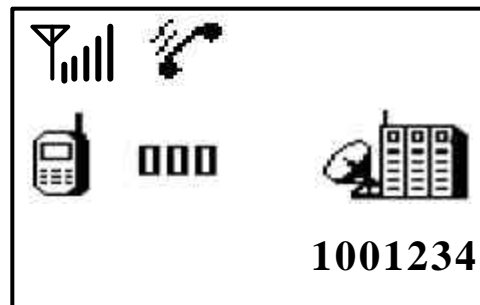

(Figure 3.1.4-1)

? The last number dialed is connected automatically.

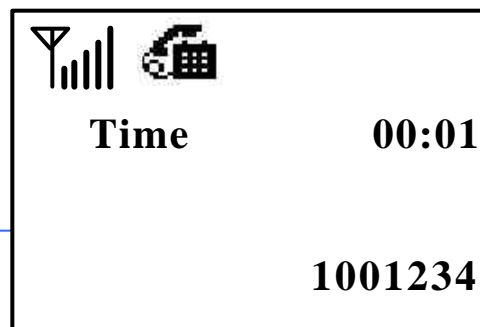

(Figure 3.1.4-2)

<Method 2>

? Press the [SND/RDL] button. The Speaker Phone operates automatically.

? The last number dialed is connected.

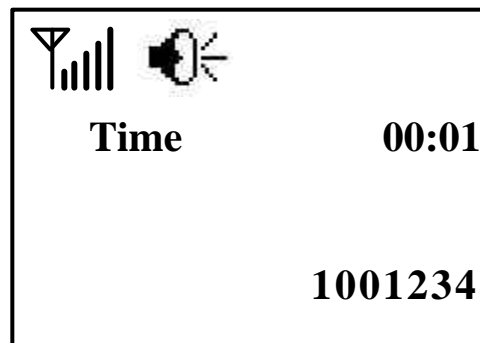

(Figure 3.1.4-3)

3.1.5 Speed Dial

This phone will store up to 99 phone numbers using 2-digit addresses (01~99) in the Phonebook. The stored numbers in the Phonebook allow a call to be placed by pressing 1-digit or 2-digit address.

This phone has the ability to search and edit numbers stored in the Phone Book. The methods for storing, searching and editing a stored phone number are explained next chapter.

3.1.5.1 One-Touch Dialing

The One-Touch Dialing function allows a call to be placed using the memory station number ([1] ~ [9]).

<Method 1>

? Pick up the handset or press the [SPK] button.

? Press the memory station number stored in the address [1] ~ [9] for approximately 2 seconds, or press the memory station number quickly, and then press the [SND/RDL] button.

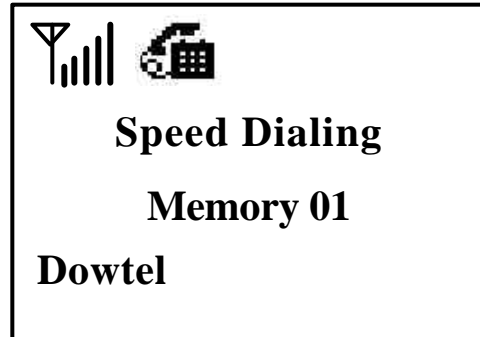

(Figure 3.1.5.1-1)

(Example)

To make a call to the number stored in address [1], press the [SND/RDL] button after pressing [1] button shortly or pressing [1] button for approximately 2 seconds.

? The number in the Phone Book is connected.

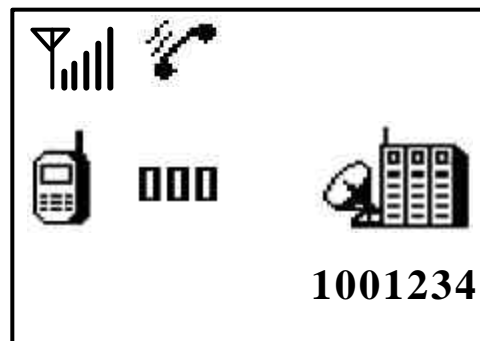

(Figure 3.1.5.1-2)

<Method 2>

? Press the button of the phone number stored in the address [1] ~ [9], and then press the [SND/RDL] button.

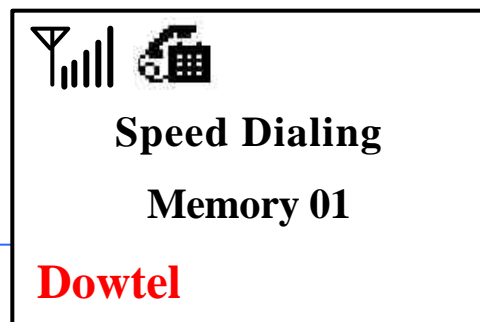

(Figure 3.1.5.1-3)

? The speaker phone operates automatically and the phone number stored in the Phone Book is connected.

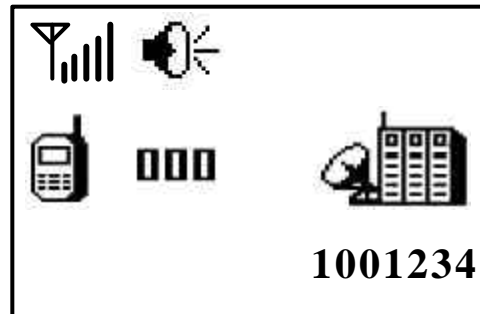

(Figure 3.1.5.1-4)

3.1.5.2 Two-Touch Dialing

To make a call using the phone numbers stored in addresses 01 through 99.

<Method 1>

? Pick up the handset or press the [SPK] button.

? Quickly press the first number, followed by the second number for approximately 2 seconds to reach the phone number stored in any address [01] ~ [99].

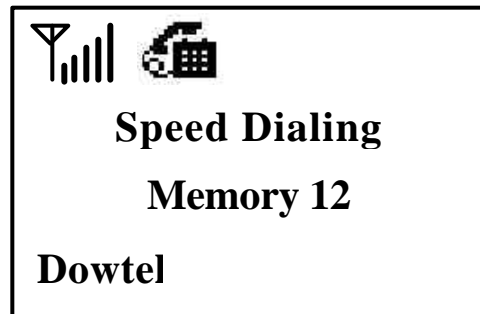

(Figure 3.1.5.2-1)

(Example)

To make a call to the number stored in address [12], quickly press the [1] button, followed by [2] button, held for approximately 2 seconds or press [1] and [2] in quick succession, followed by the [SND/RDL] button.

? The number in the Phone Book is connected.

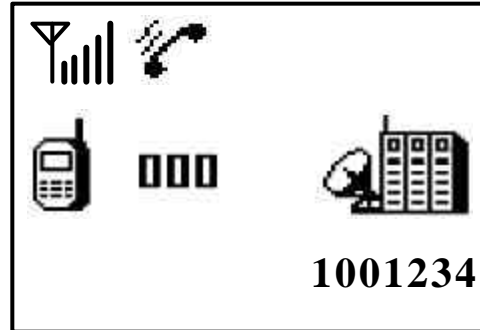

(Figure 3.1.5.2-2)

<Method 2>

? Press the button of the phone number stored in any Address [10] ~ [99], and then press the [SND/RDL] button.

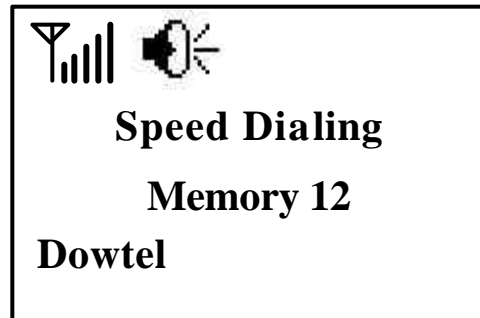

(Figure 3.1.5.2-3)

? The speaker phone operates automatically and the phone number stored in the Phone Book is connected.

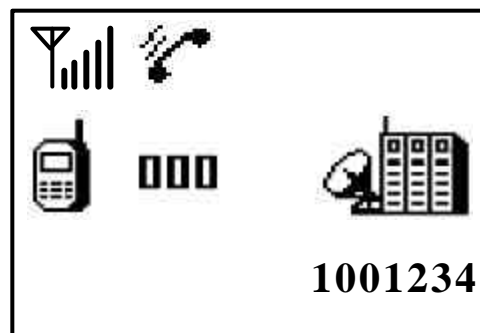

(Figure 3.1.5.2-4)

3.2 Answering Calls

3.2.1 On-Hook State

? When a call is being received, the phone will ring.

? If the system supports a caller ID service, the calling party information will be displayed on the third line of the screen. If the calling party number is stored in the Phone Book, the stored information will be displayed on the fourth line of the screen.

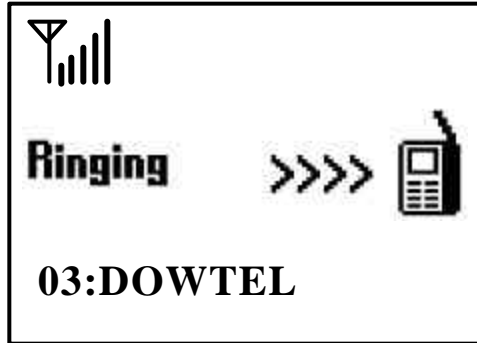

(Figure 3.2.1-1)

[Note]

The calling party information is not displayed unless the service provider provides Caller ID service.

? Pick up the handset or press the [SPK] button to connect the call.

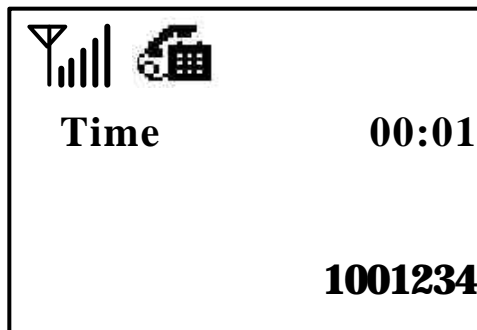

(Figure 3.2.1-2)

3.2.2 Off-Hook State

? If a call is being received while the handset is picked up or the speaker is on, click the Hook Switch or press [SPK]



(Figure 3.2.1-3)

button, to connect the call.

? The Figure 3.2.2-2 is displayed on the screen.

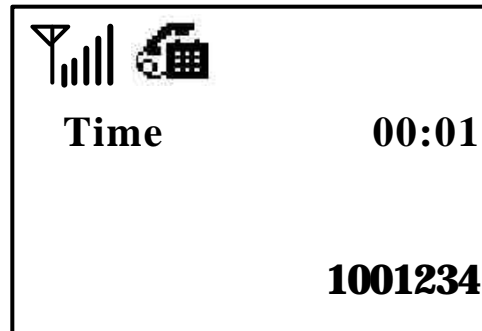

(Figure 3.2.2-2)

3.3 Disconnecting Calls

3.3.1 Using the Handset

? Hang up the handset when the call is finished.

? If the calling party hangs up the phone first, the warning-tone sound will be heard through the earpiece until the handset is placed on the receiver.

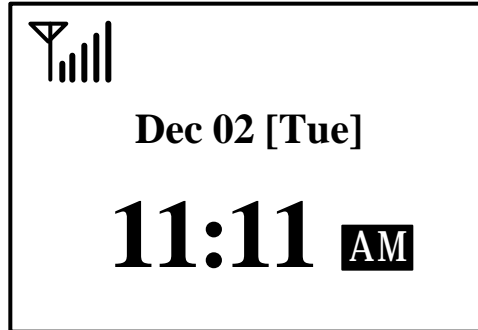

(Figure 3.3.1)

3.3.2 Using the Speaker Phone

? Press the [SPK] button when the call is finished.

? If the calling party hangs up the phone first, the [SPK] lamp will turn off automatically and the speaker phone will not operate.

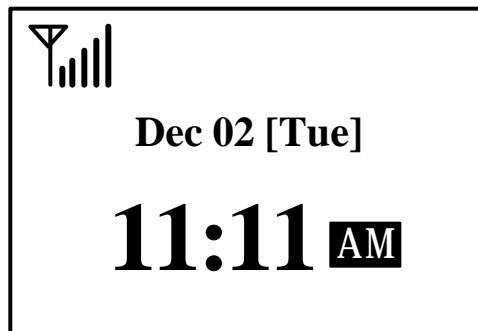

(Figure 3.3.2)

3.4 Transfer Between Handset & Speaker Phone

3.4.1 Transfer to Speaker Phone in Off-Hook State

? When the [SPK] button is pressed in the Off-Hook state, the

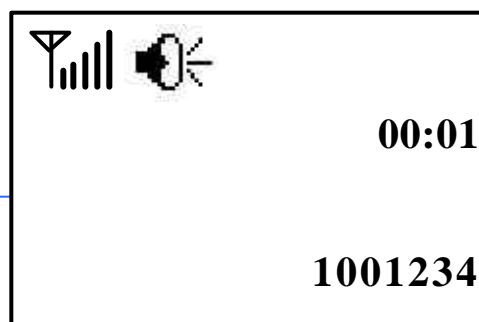

[SPK] lamp will turn on and the callers voice will be heard through the speaker.

3.4.2 Transfer to Handset in Speaker ON State

? If the handset is picked up when the [SPK] lamp is on, the [SPK] lamp will turn off and the callers voice will be heard through the earpiece.

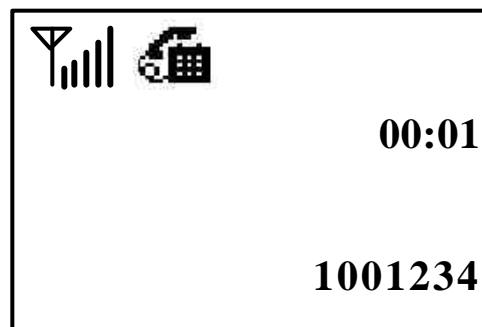

(Figure 3.4.2)

3.5 Volume Control

Following 4 volumes can be adjusted from low to high in 5 different volume levels.

3.5.1 Keypad Tone Control

? The Keypad Tone volume can be adjusted by pressing [?] or [?] button when the handset is on the receiver and the [SPK] button is off.

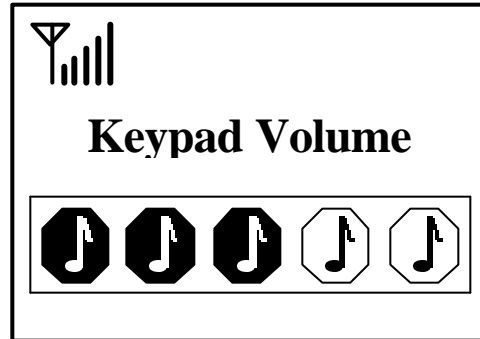

(Figure 3.5.1)

3.5.2 Ear Volume Control

? After the handset is picked up, the loudness of the earpiece can be adjusted by pressing [?] or [?] button.

[Note]

In this case the Keypad Beep Tone volume will not be changed even though the earpiece volume has been adjusted.

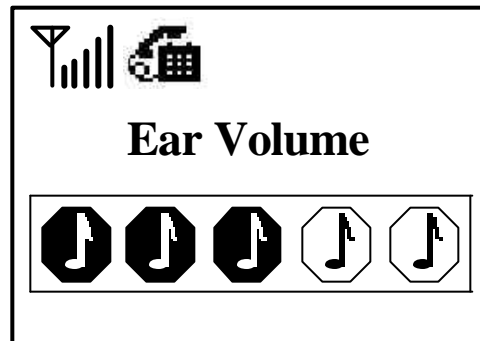

(Figure 3.5.2)

3.5.3 Speaker Volume Control

? After the [SPK] button is activated, the Speaker Volume can be adjusted by pressing [?] or [?] button.

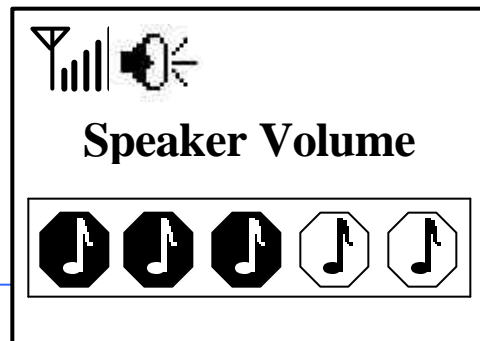

(Figure 3.5.3-1)

3.5.4 Ringer Volume Control

? The Ringer Volume can be adjusted by pressing [?] or [?] button while the phone is ringing.

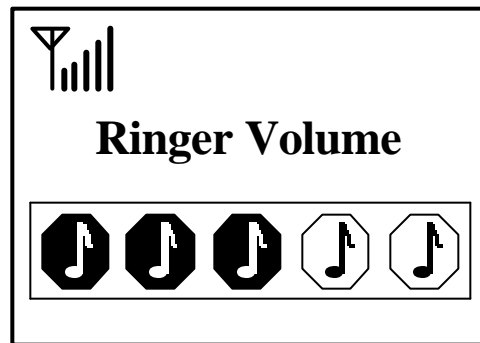

(Figure 3.5.4-1)

3.6 Hot Line

This function is used to make an automatic call to a designated number without dialing the designated number and pressing the [SND/RDL] button.

Hot Line operates in 2 modes.

? Timed Hot Line : Makes a call to the designated number without dialing or pressing the [SND/RDL] button within the Sending Time (4 ~ 8 seconds)

after picking up the handset.

- ? **Immediate Hot Line** : Automatically makes a call to the designated number as soon as the handset is lifted from the receiver.

The Hot Line number may be registered at address 99 in the Phone Book using the Phone Book function. (Reference 4.4 Using the Phone Book)
Use the Menu Mode (Reference 5.4.3 Hotline Call) to set up the Hot Line function (ON/OFF) and the Sending Time.

<Note>

This function only operates when the Hot Line function is on and only after the Hot Line number is registered at address 99 in the Phone Book.

3.6.1 Timed Hot Line

- ? Pick up the handset or press the [SPK] button.

- ? If the phone is not dialed or if the [SND/RDL] button is not pressed during the sending time (4~8 seconds), the call is connected automatically **(Default sending time is 6 seconds).**



(Figure 3.6.1)

- ? If the phone is dialed or if the [SND/RDL] button is pressed within the sending time, the Hot Line function will be canceled

3.6.2 Immediate Hot Line

When the handset is lifted from the receiver or when the [SPK] button is pressed, the Hot Line is immediately connected.

3.7 Do Not Disturb (DND)

Set the DND function to avoid incoming calls when you are not in the mood to be disturbed by an incoming call.

[Setting ON]

? Press the [DND/MUTE] button when the handset is on the phone and the [SPK] lamp is off. The DND icon will flash and “Do not disturb” message will be displayed simultaneously.

? When there is an incoming call, the phone will not respond the call.

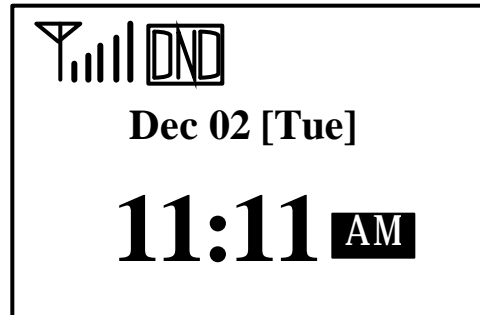

(
(Figure 3.7-1)

[DND Setting OFF]

? Press the [DND/MUTE] button when the handset is on the receiver and the [SPK] lamp is off.

? The DND icon and “Do not disturb” message will disappear and the phone will return to the normal operating mode.

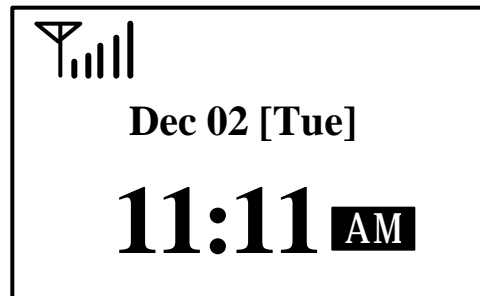

(Figure 3.7-2)

3.8 Microphone Mute

3.8.1 Functions

Use the Microphone Mute function to block transmission of voice or surrounding sound of a caller and the keypad tone during a conversation to the party called.

3.8.2 Using Function

? Press the [DND/MUTE] button to block the outgoing voice during the conversation.

A mute icon will be displayed as shown in Figure 3.8.2-1 and a voice and surrounding sound of a user will not be heard at the other party.

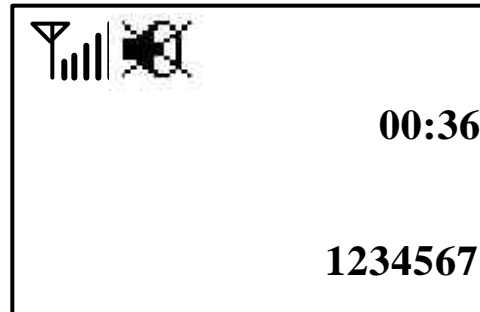

(Figure 3.8.2-1)

? Press the [DND/MUTE] button to remove the Mute function, then a speaker and a microphone will again activate to enable the other party to hear a voice and surrounding sound.

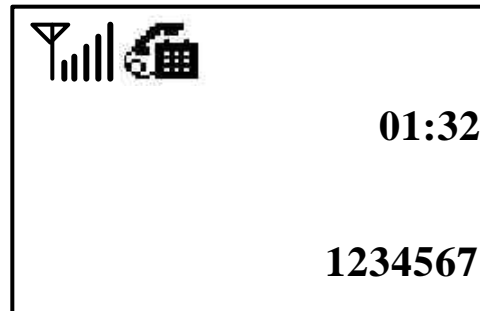

(Figure 3.8.2-2)

<Note>

This function is valid for a single call. After the call is finished, the phone is returned to [Unmute] status automatically. So the additional setting for [Unmute] is not necessary.

4. Additional Functions

4.1 Short Message Service (SMS)

The phone is capable of transmitting and/or receiving simple text or voice

messages.

? When a text message is received, an icon(Figure 4.1-1) will appear on the screen accompanied by the SMS/VMS notification tone.

? To retrieve a text message, press [CLR] button to return to the idle-state of the screen and then press [MSG/VAS] button.

Select button <1> to read the received message.

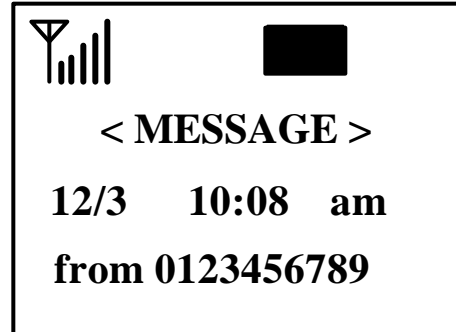

(Figure 4.1-1)

? When a voice message is arrived, an icon(Figure 4.1-2) will appear on the screen accompanied by the SMS/VMS notification tone.

? To retrieve a voice message, press [CLR] button to return to the idle-state of the screen and then press [MSG/VAS] button.

Select button <1> to get the received voice mail.

The phone number of the calling party and the number of the message stored in the Message Center will appear on the screen, and the [VMC] menu will appear on the bottom of the screen. At this time, press the [STORE] button and then [SEND] button to go to the Message Center.

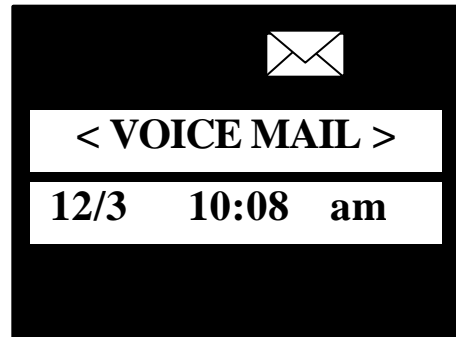

(Figure 4.1-2)

? To send the text message,

- 1) Press the [MSG/VAS] button at the idle state of the screen,
- 2) Press button <2> to input a phone number of a receiver and press [STORE] button,
- 3) Write the message and then press [STORE] button,
- 4) Input the phone number of a sender and then press [STORE] button,
- 5) And select priority,
- 6) Finally press [STORE] button, to send the text message.

4.2 Alarm Reminder

After setting this Alarm Reminder function with a desired alarm time, the phone will ring to alarm a user at the specified time.

[Reference]

- There are two types of mode; Onetime Mode and Always Mode
- **Onetime Mode;**
If the phone is set to the Onetime Mode, the alarm will ring at the specified time just one time.
The setting mode will be released automatically.
- **Always Mode;**
With this mode, the alarm rings at a specified time every day until the setting value is released. The method of setting/editing this function is explained in the next chapter (5.5.1 Alarm Setting).

When the alarm rings:

- ? Pick up the handset or press [SPK/RDL] button. This action will cause the ring to stop and the phone to return to its normal state.
- ? If no action is taken during the alarm, the ring will be stopped automatically after 30 seconds.

4.3 Voice Privacy (System Dependent)

There are "Standard" and "Enhanced" in the Voice Privacy function. Standard basically provides the confidential function of IS-95A. Enhanced is a more upgraded one for the confidential function and is selected according to a customer's demand.

4.3.1 In Idle State (On-Hook State)

- ? Press; [MENU] → 3 → 3
- ? Select <Enhanced> mode or <Standard> mode by using [?] or [?] button, followed by the [STORE] button.

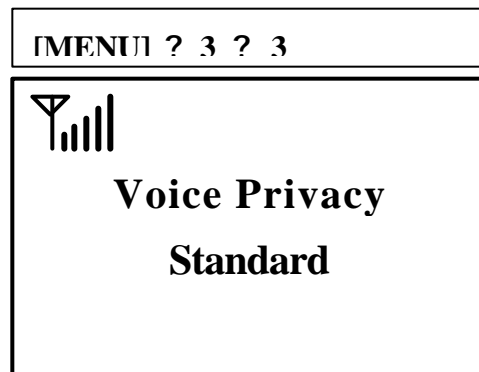

(Figure 4.3.1)

4.3.2 During a Conversation

? Press [MENU] button during a conversation and press <1>.

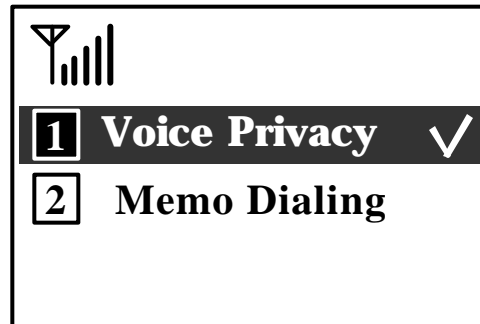

(Figure 4.3.2-1)

? Select <Enhanced> mode or <Standard> mode by using [?] or [?] button, followed by the [STORE] button.



(Figure 4.3.2-2)

4.4 Authentication (System Dependant)

The phone has its own authentication key function. This will prohibit any illegal use of the phone. Your service provider will need to register your phone using this authentication function.

4.5 Using the Phone Book

4.5.1 Storing a Phone Number in Idle-State

? When the phone is in idle-state,

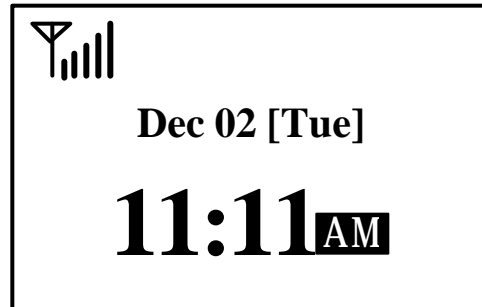

(Figure 4.5.1-1)

? Enter the phone number using the dial button, followed by the [STORE] button.

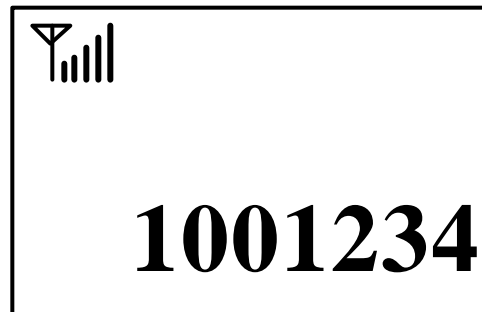

(Figure 4.5.1-2)

? The Figure 4.5.1-3 is displayed on the screen.

? Type the name using the dial button, followed by the [STORE] button.

? To pass over the name entry, skip the above steps, and press the [STORE] button directly.

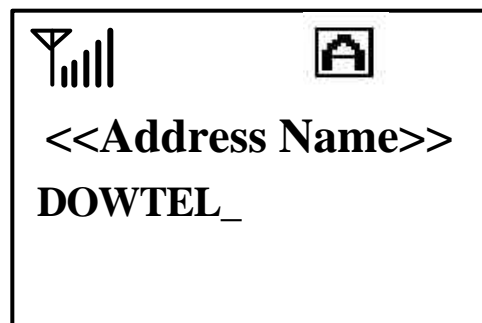

(Figure 4.5.1-3)

? The Figure 4.5.1-4 is displayed on the screen asking the memory location.

? Press the memory location number to store the phone number, followed by the [STORE] button.

? In this example, if the [STORE] button is immediately pressed, the number is stored at memory location number [03].

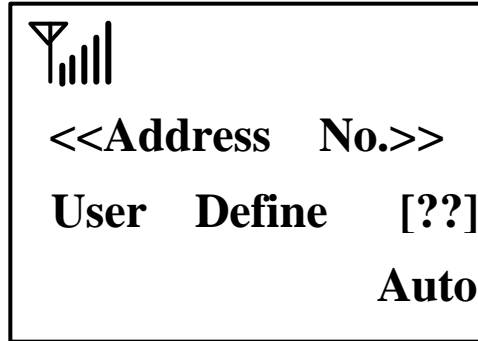

(Figure 4.5.1-4)

4.5.2 Storing a Memo During a Conversation

During a conversation, a number memo may be entered using the dial button. This function is used to make a notation of a number that may be later stored in the Phone Book. Additionally, the number notated in the memo may be accessed to place a call to that number after the current call is finished.

? During a conversation, press the [MENU] button



(Figure 4.5.2-1)

? Press the [2] button, and then enter the phone number using the keypad.

? Even though the dial button is pressed during a call, the keypad tone will not be transmitted to the other party and the number will only be

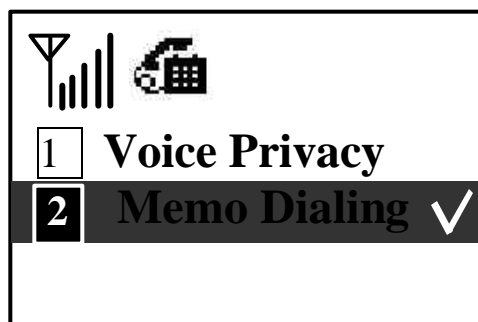

(Figure 4.5.2-2)

displayed on the screen as a number memo.

? After the current call is finished, the number memo will remain on the screen until the handset is either picked up or another button is pressed.

? To store the number memo as a stored number in the Phone Book, press the [STORE] button. (Reference 4.5.1)

? To call the number in the number memo, press the [SND/RDL] button.



(Figure 4.5.2-3)

4.5.3 Searching for a Stored Number

? When the phone is in idle-state, the screen (Figure 4.5.3-1) is displayed after pressing the [RCL] button.

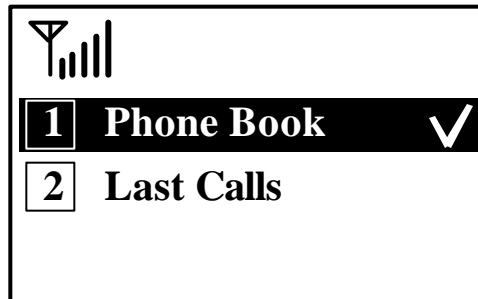

(Figure 4.5.3-1)

? When the [1] button is pressed, the screen (Figure 4.5.3-2) is displayed.

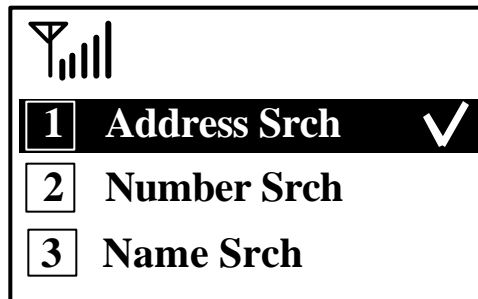

(Figure 4.5.3-2)

4.5.3.1 Address Srch

? The Address Srch is displayed on the screen by pressing the [1] button. (Figure 4.5.3-3)

? Enter the memory location number using the dial button.

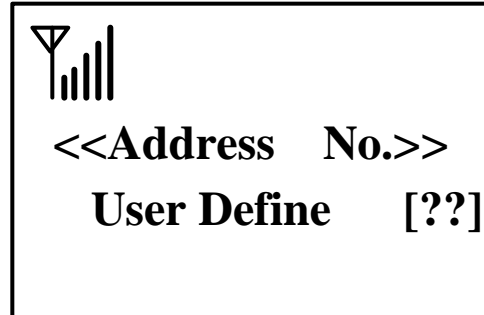

(Figure 4.5.3-3)

? The name and number are displayed on the screen as shown in Figure 4.5.3-4

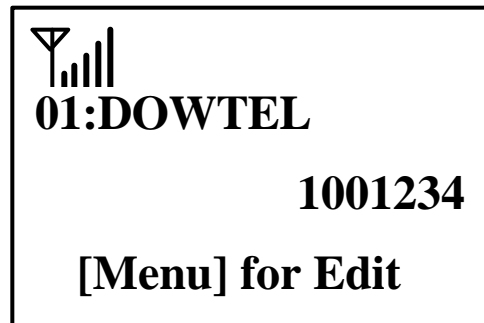

(Figure 4.5.3-4)

4.5.3.2 Number Srch

? If the [2] button in the Figure 4.5.3-2 is pressed, the screen (Figure 4.5.3-6) is displayed on the screen.

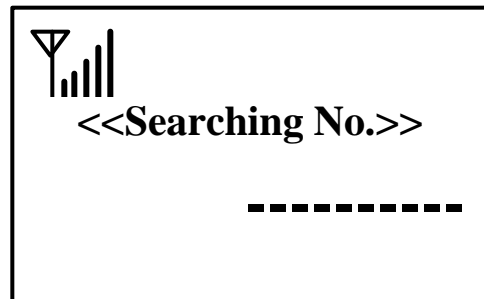

(Figure 4.5.3-6)

4.5.3.3 Name Srch

? If the [3] button in the Figure 4.5.3-2 is pressed, the screen (Figure 4.5.3-7) is displayed on the screen.

? Enter the name to search using the dial button, and then press the [STORE] button.

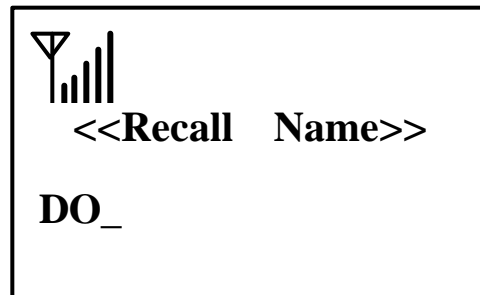

(Figure 4.5.3-7)

? All stored names are displayed on the screen as shown in Figure 4.5.3-8.

? Select the address using the [?] or [?] button, followed by the [STORE] button. The number of stored address is displayed.

? To make the call, press the [SND/RDL] button or pick up the handset.,

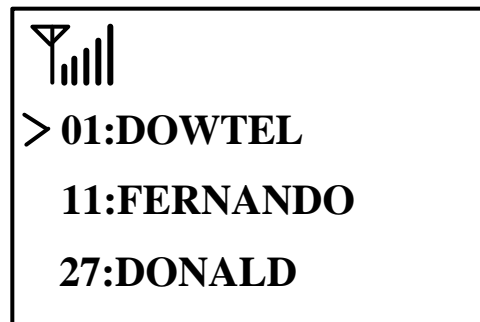

(Figure 4.5.4-8)

4.5.3.4 All Lists

? If the [4] button is pressed (Figure 4.5.3-2), the screen (Figure 4.5.3-9) is displayed.

? Select the number using the [?] or [?] button, followed by the [STORE] button. The number of the stored number is displayed.

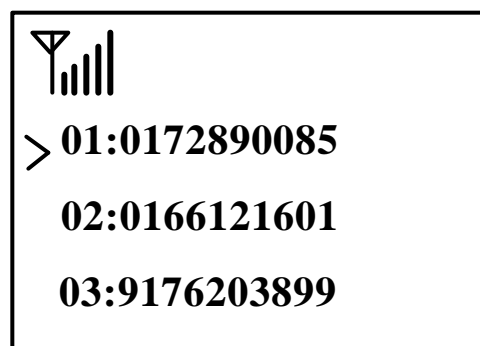

(Figure 4.5.3-9)

? Press the [SND/RDL] button or pick up the handset, and call will be made.

4.5.4 Editing a Stored Number

? When searching for a number using the stored address or name, the screen (Figure 4.5.4-1) is displayed.

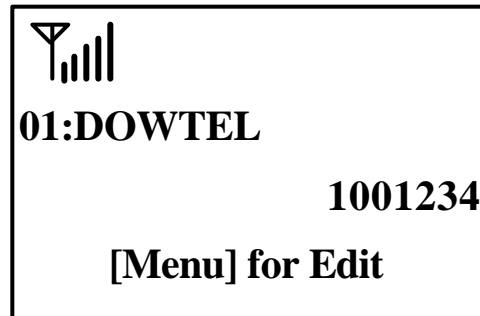

(Figure 4.5.4-1)

? Press the [Menu] button in the Figure 4.5.5-1, and the screen is changed (Figure 4.5.4-2.)

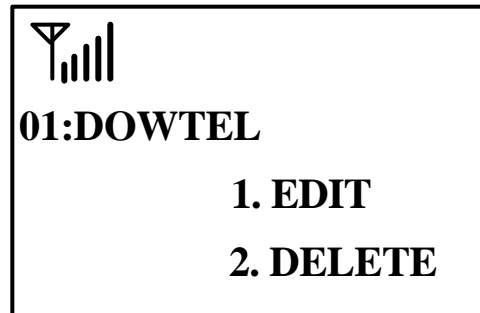

(Figure 4.5.4-2)

? Select the [1] button (Figure 4.5.4-1), and change the number using the [CLR] and dial button.

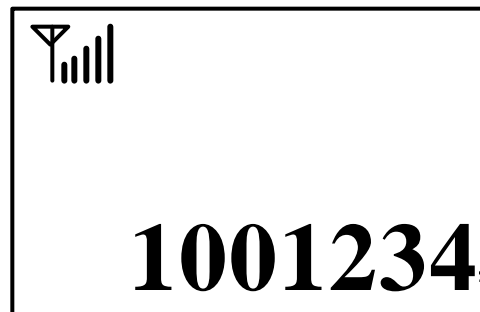

(Figure 4.5.4-3)

? After changing the number in Figure 4.5.4-3, press the [STORE] button.

? The screen is changed automatically as shown in Figure 4.5.4-4. The name may then be changed using the [CLR] followed by the dial button.

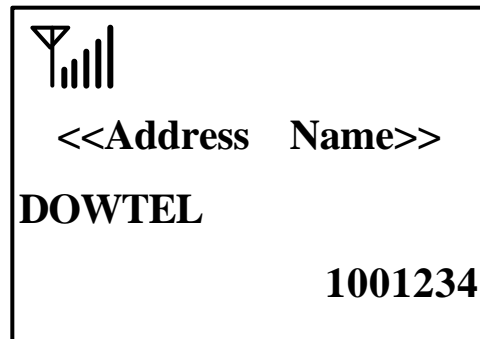

(Figure 4.5.4-4)

? To store the original address or to enter another desired address into 01 ~ 99, press the [STORE] button.

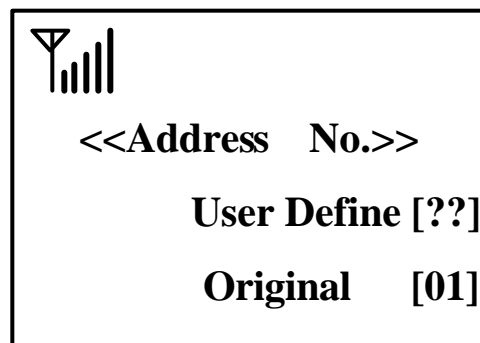

(Figure 4.5.4-5)

? When the address entered (Figure 4.5.4-4) already has existed or stored in the phone book, the Overwrite option will appear to replace the address or not.

? If "Yes" is selected, the address will

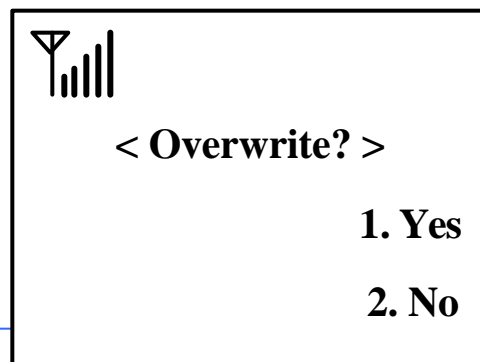

(Figure 4.5.4-6)

be replaced.

? If "No" is selected, the screen will return to Figure 4.5.4-5. The original number will remain at that address and the new number will be stored at a new address.

? When above all storing procedures are finished, the stored address and name will be displayed on the screen.

? After a few seconds, the phone will return to the idle-state.

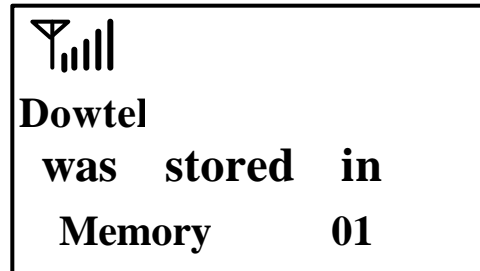

(Figure 4.5.4-7)

4.5.5 Erasing a Stored Number

? Search for the number using the address or name, the screen (Figure 4.5.5-1) is displayed. (Reference 4.5.3)

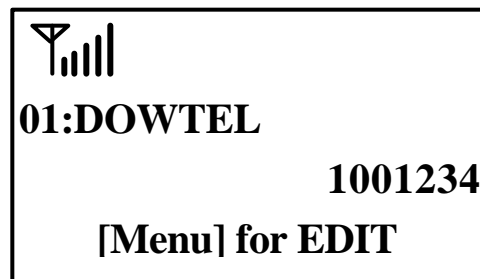

(Figure 4.5.5-1)

? Press the [Menu] button in the Figure 4.5.5-2, and the screen goes to the edit state.

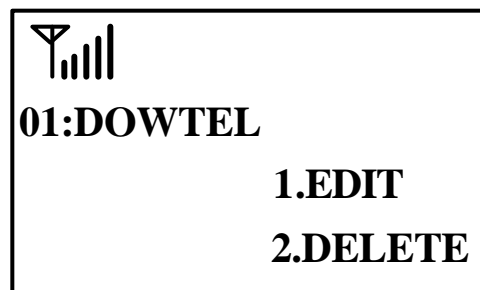

(Figure 4.5.5-2)

? If the [2] button is selected (Figure 4.5.5-2), the screen will be changed (Figure 4.5.5-3).

? If "Yes" is selected, the address will be erased.

? If "No" is selected, the address will not be erased and the screen will be changed (Figure 4.5.5-1).

? Figure 4.5.5-4 illustrates the erase procedure is in process because "Yes" was selected by a [1] button.

? After a few seconds, the phone will return to the idle-state.

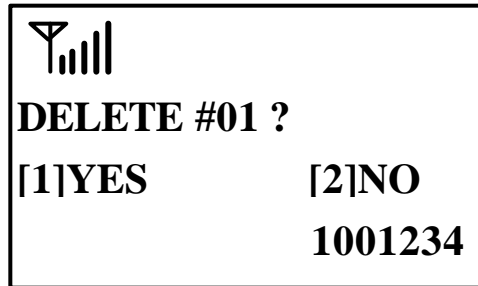

(Figure 4.5.5-3)



(Figure 4.5.5-4)

4.6 List of Numbers Dialed

4.6.1 Last Calls

? Press the [RCL] button when the phone is in the idle-state.

? When the [2] button is pressed, the screen (Figure 4.6.1-1) is displayed.

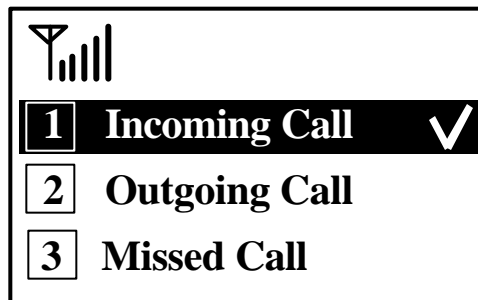

(Figure 4.6.1-1)

4.6.1.1 Incoming Call

? When the [1] button is pressed, the screen (Figure 4.6.1-2) is displayed.

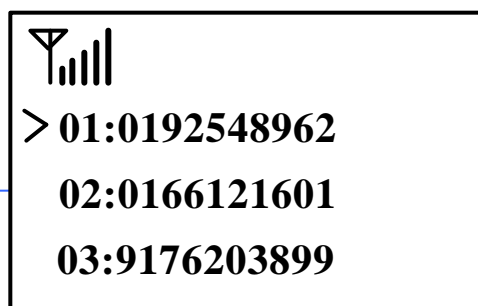

(Figure 4.6.1-2)

? The incoming call list of up to 10 numbers is displayed.

4.6.1.2 Outgoing Call

? The outgoing call list of up to 10 numbers previously dialed will be displayed on the screen if [2] button is pressed in Figure 4.6.1.2

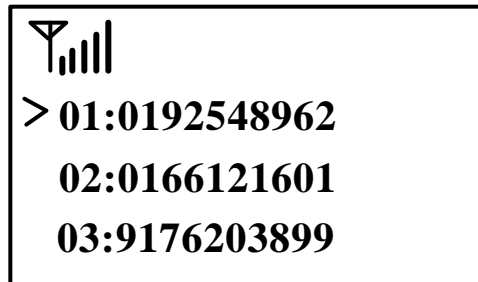

(Figure 4.6.1.2)

4.6.1.3 Missed Call

? The missed call list of up to 10 numbers will be displayed on the screen if [3] button is pressed in Figure 4.6.1.3

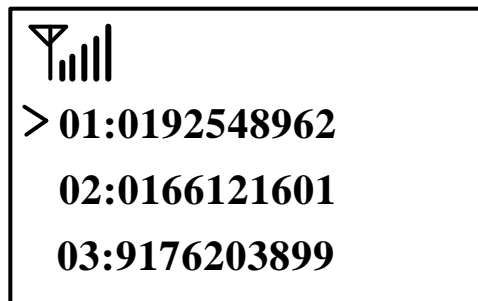

(Figure 4.6.1.3)

4.7 DATA Service

4.7.1 Definition

WS-2000/4000 provides Data and Fax service. It is capable of transmitting and receiving Data or Facsimile information through a wireless path by being connected to a Notebook (or Desktop PC).
The following services are available.

- ? **Async Data Service**
 - File transmit and receive
 - PC communication
- ? **PC Fax Service**
 - Wireless Fax transmit/receive using the Winfax or Hotfax
- ? **Packet Data Service**
 - FTP, Internet, Intranet, LAN, E-Mail etc.

4.7.2 Using the Data Service

Reference the Appendix B. Data Service Manual.

<Note>

To receive data using the Async Data Service and PC Fax Service. (Reference 5.5.2 PC Fax & Modem and Table DS-1), set the WS-2000/4000 to the receiving mode.

[Note]

- ? This phone supports both Async Data Service benefiting the large capacity of file transmission at 14.4kbps as the international standard and Packet Data Service ideal in the business which requires the frequent access.
- ? An Internet account (free or charged) must be acquired by a service provider to use the Packet Data Service,

5. Menu

5.1 Menu Mode

5.1.1 Main Menu

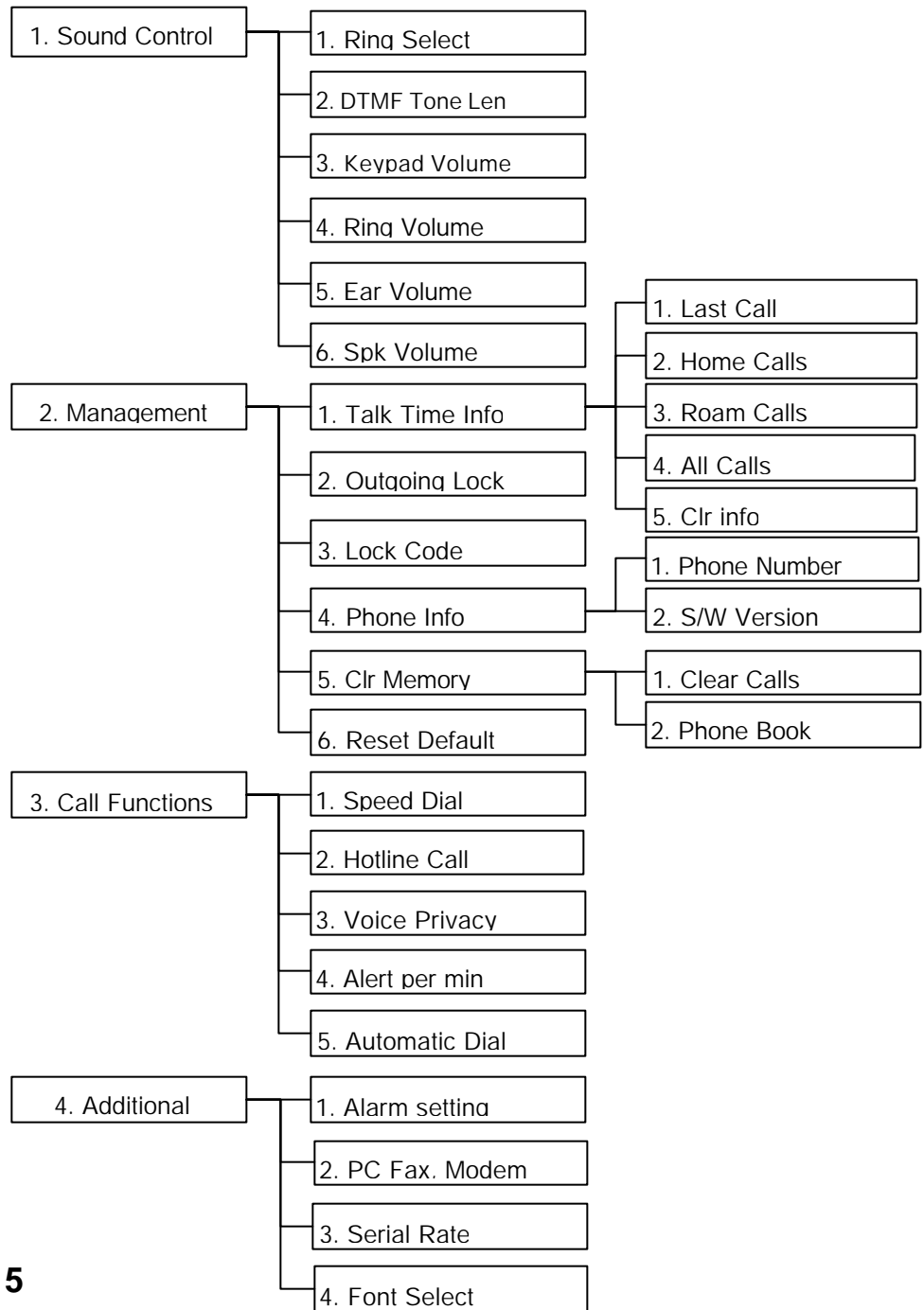

5

.1.2 Additional Menu

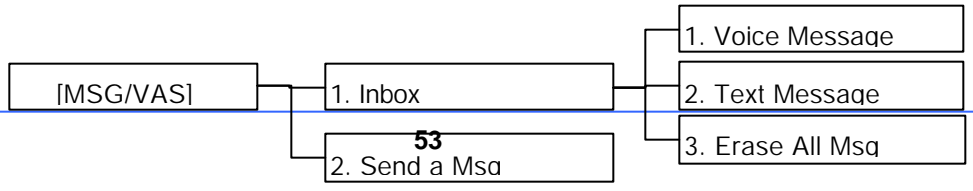

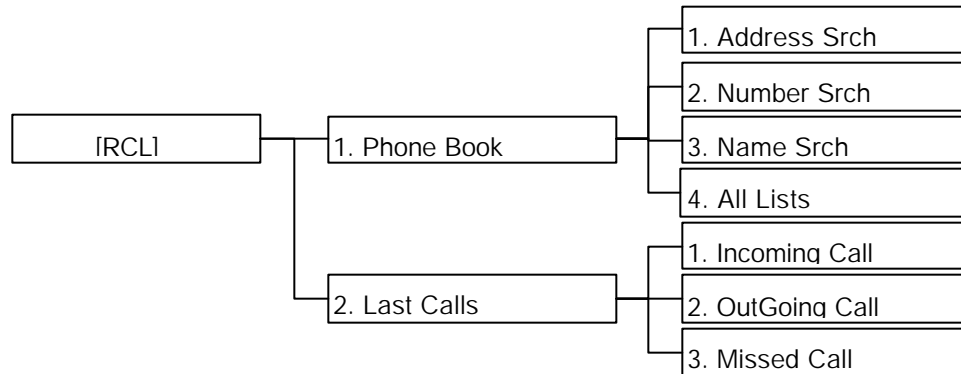

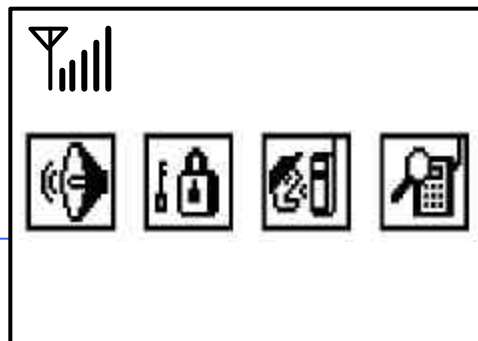

? To go to menu mode, press [MENU] and the screen will appear as Figure 5.1.



(Figure 5.1) Main Menu

? To go sub-menu, press [MENU],
 select the icon and press [STORE] or or
 butt  

5.2 Sound Control

Tone, Sound volume and ring types can be adjusted by using the Menu Mode.

? In Figure 5.1 above, press [1] button or [?] or [?] button, and it will display Figure 5.2. Then, when [STORE] button is pressed, <Sound Control> menu becomes selected.

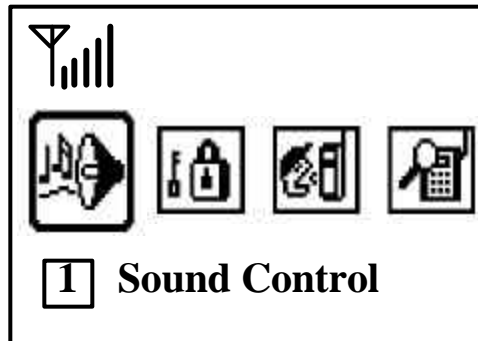

(Figure 5.2) Sound Control Menu

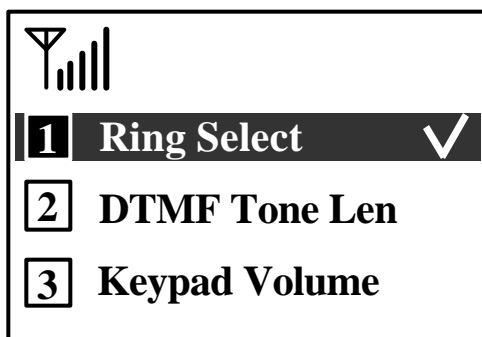

(Figure 5.2-1) Sound Control Menu 1

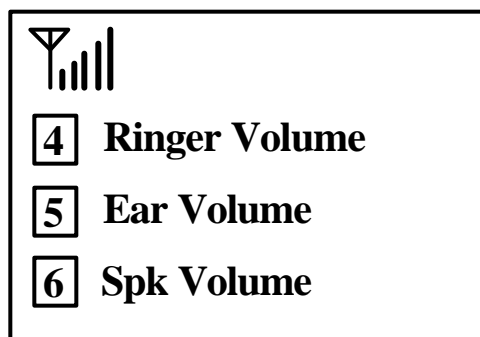

(Figure 5.2-2) Sound Control Menu 2

5.2.1 Ring Select

To select the type of Ring when a call is received,

? Press ;

[MENU] ® 1 ® 1

[MENU] ? 1 ? 1

There are 6 Bell-Type and 4 Melody-Type rings available.

? The screen (Figure 5.2.1) is displayed with the current ring setting

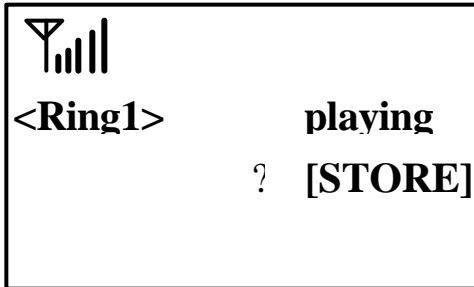

To store the ring type, use [?] or [?] button to select the desired ring type and then press [STORE] button.

(Figure 5.2.1) Ring Select

5.2.2 DTMF Tone Length

When dial buttons are pressed during a calling state for the additional service of system or for the connection with ARS system, DTMF Tone length which is transmitted over the air can be selected into 2 types of mode;

- <Short Mode> that sends DTMF Tone for 0.2 seconds after pressing the dial button.
- <Long Mode> that sends DTMF Tone continuously as long as the dial button is pressed.

? Press;

[MENU] ® 1 ® 2

[MENU] ? 1 ? 2

? The screen (Figure 5.2.2) is displayed.

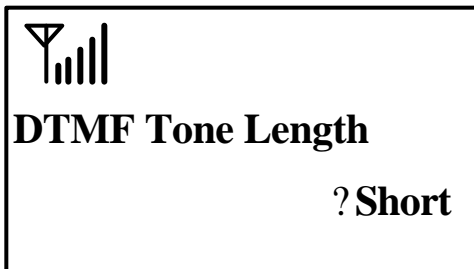

? At this time, select the DTMF Mode desired using the [?] or [?] button, followed by the [STORE] button to save.

(Figure 5.2.2) DTMF Tone Length

5.2.3 Keypad Volume

The Keypad Volume menu is used to adjust the keypad tone volume in <Silent> or 5-volume levels.

? Press ;

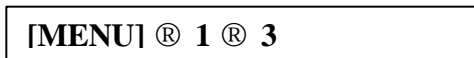

[MENU] ® 1 ® 3

? The current tone level is displayed on the screen (Figure 5.2.3).

? Select the tone level desired using the [?] or [?] button, followed by the [STORE] button.

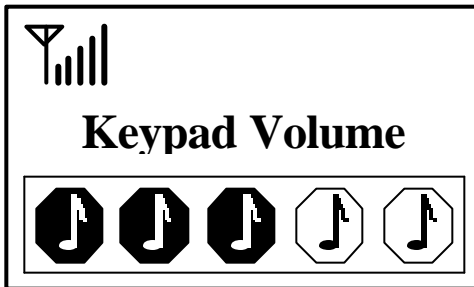

(Figure 5.2.3) Keypad Tone Volume

[Speed Menu]

To select the tone level, use the [?] or [?] button when the handset is on the receiver(On-Hook state) and [SPK] lamp is off.

5.2.4 Ring Volume

The Ring Volume menu is used to select the ringer volume in case of an incoming call. This function ranges from <Silent> mode to 5-volume levels.

? Press;

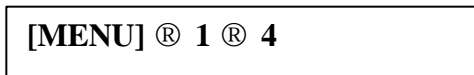

[MENU] ® 1 ® 4

? The current volume level is displayed on the screen (Figure 5.2.4).

? Select the volume level desired using the[?] or [?] button followed by the [STORE] button to store the ringer volume setting.

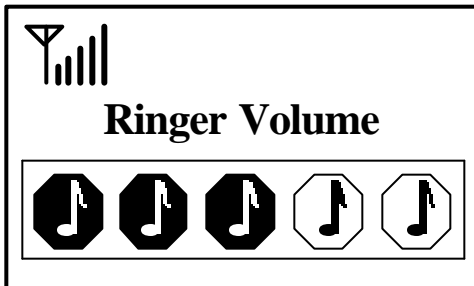

(Figure 5.2.4) Ringer Volume

[Speed Menu]

To select the volume level, use the [?] or [?] button while the phone is ringing. It will display Figure 5.2.4 allowing the adjustment of the ringer volume level.

5.2.5 Ear Volume

The Ear Volume menu is used to select the earpiece volume. This function has 5-volume levels.

? Press;

[MENU] ® 1 ® 5

? The current volume level is displayed on the screen (Figure 5.2.5).

? Select the volume level desired using the [?] or [?] button followed by the [STORE] button to store the volume setting.

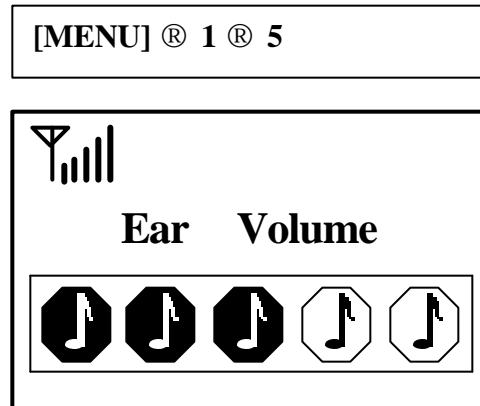

(Figure 5.2.5) Ear Volume

[Speed Menu]

To select the volume level, use the [?] or [?] button while the handset is lifted from the receiver (Off-Hook state). Figure 5.2.5 will be displayed directly.

5.2.6 Spk Volume

The Spk Volume menu is used to select the speaker volume level. This function has 5-volume levels.

? Press;

[MENU] ® 1 ® 6

? The current volume level is displayed on the screen (Figure 5.2.6).

? Select the volume level desired using the [?] or [?] button followed by the [STORE] button to store the volume setting.

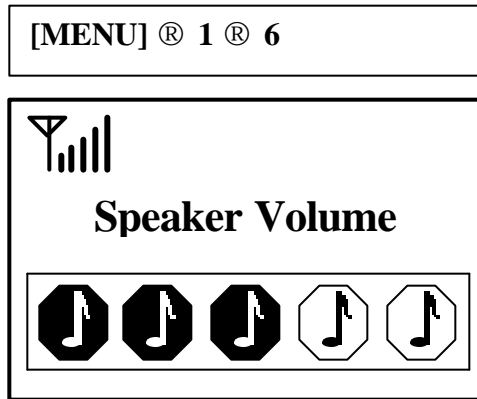

(Figure 5.2.6) Speaker Volume

[Speed Menu]

To select the volume level, use the [?] or [?] button when the [SPK] lamp is on. Figure 5.2.6 will be displayed directly.

5.3 Management

Important information such as limiting the use of a phone, Phone Book erasing, and resetting as default are included in this menu and the Pass Code is required to limit others from using the phone.

? Press [2] button or use [?] or [?] button. If the screen changes to Figure 5.3, press [STORE] button to enter the <Management> menu.

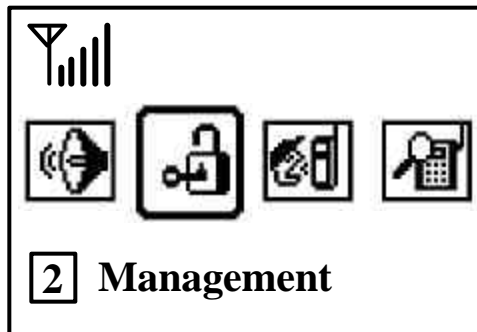

(Figure 5.3)

? Press; **[MENU] ® 2**

[MENU] ® 2

? The phone requests the user's password (Figure 5.3-1.)

The default password is "0000".

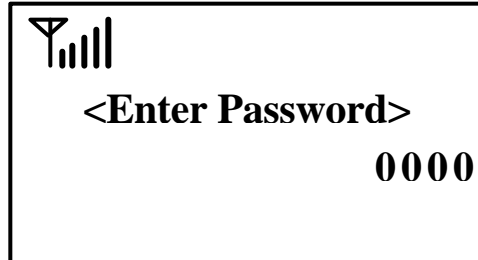

(Figure 5.3-1)

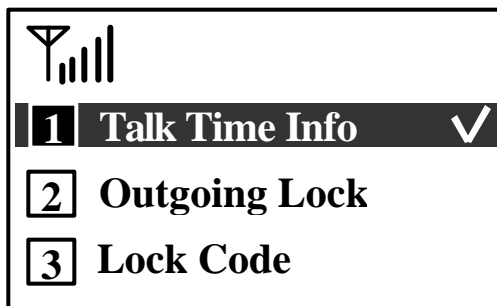

(Figure 5.3-2) Management Menu 1

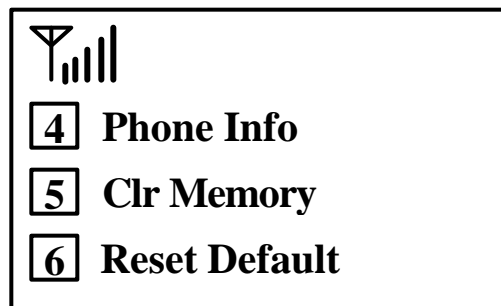

(Figure 5.3-3) Management Menu 2

5.3.1 Talk Time Info(Information)

The function enables a user to search or erase the recent call time or the total call time recorded.

? Press ; **[MENU] ® 2 ® Password ® 1**

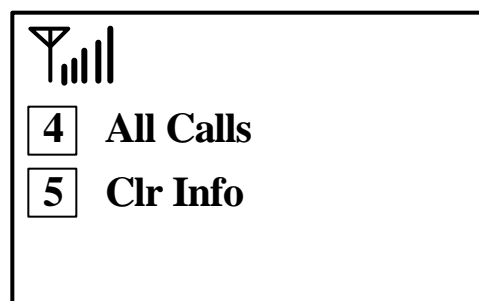
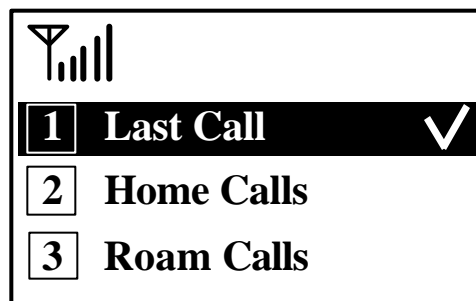

(Figure 5.3.1)

[Note]

The items shown in numbers 1 and 2 in this menu are initialized automatically when the power is turned off and on again.

5.3.1.1 Last Call

? The last number dialed is displayed on the screen when the [1] button is pressed (Figure 5.3.1.)

? The call time shows [Hour:Minute:Second] (Figure 5.3.1-1)

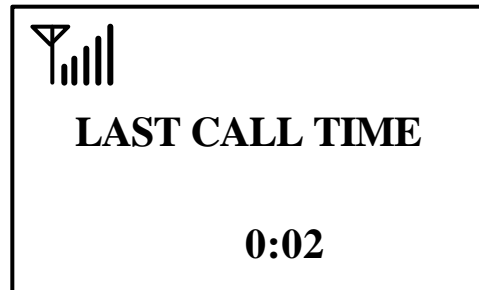

(Figure 5.3.1-1)

5.3.1.2 Home Calls

? The Home calls time is displayed on the screen by pressing the [2] button (Figure 5.3.1.)

? The Home calls time is displayed [Hour:Minute:Second] in order. (Figure 5.3.1-2)

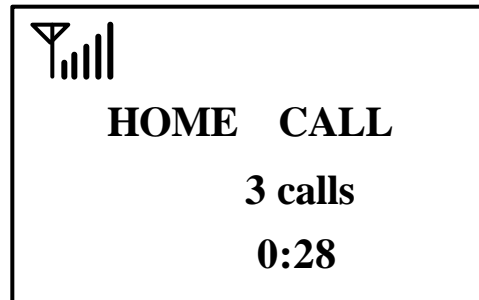

(Figure 5.3.1-2)

5.3.1.3 Roam Calls

? The call time at the Roaming side, not at the home side, will be displayed on the screen if [3] button is pressed in Figure 5.3.1.

? The Roam calls time shows [Hour:Minute:Second] in order (Figure 5.3.1-3).

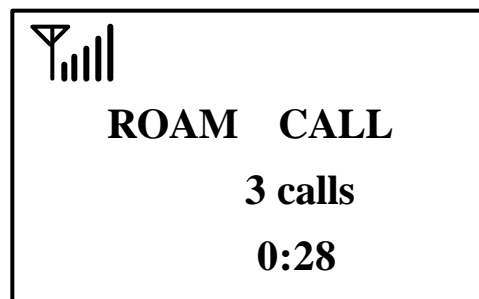

(Figure 5.3.1-3)

5.3.1.4 All Calls

? All outgoing calls time will be displayed on the screen if [4] button is pressed in Figure 5.3.1.

? The calls time shows [Hour:Minute:Second] in order (Figure 5.3.1-4).

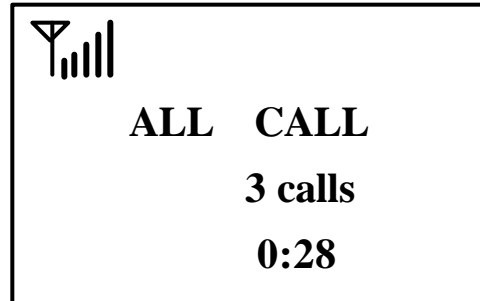

(Figure 5.3.1-4)

5.3.1.5 Clear Information

The above items are initialized automatically when the power is turned off and on again. But these items can be also initialized by using the following menu;

? Press the [5] button in Figure 5.3.1 to display the information screen of Figure 5.3.1-5.

? Press the [1] button, to erase the records.

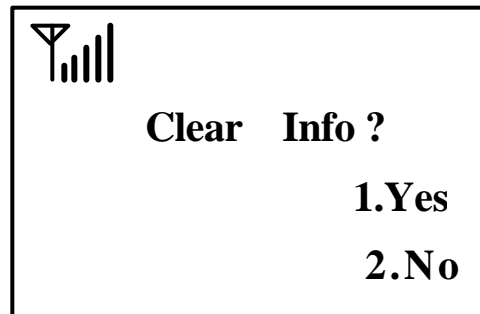

(Figure 5.3.1-5)

5.3.2 Outgoing (Call) Lock

This menu is used to limit or permit a call.

? Press ;

[MENU]→2→Password→2

? The <Yes>/<No> menu is toggled in the bottom of the screen by [?] or [?] button.

? When the <Yes> menu is displayed, press the [STORE] button to set this mode to limiting an outgoing call. Once set, outgoing calls can not be made.

[MENU]® 2® Password® 2

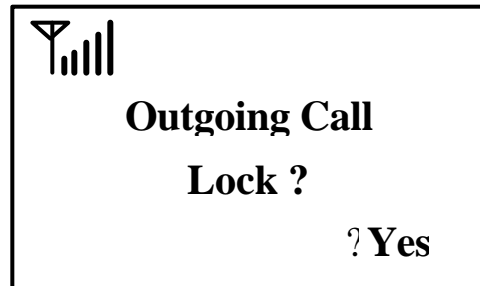

(Figure 5.3.2)

5.3.3 Lock Code (Edit)

This menu is used to change the user's password.

? Press;

[MENU]? 2→Password→3

? Enter the new password using dial button, and then press the [STORE] button to save.

? To ensure the correct password was recorded in Figure 5.3.3-1, a prompt to reenter the new password will appear.

? Enter the new password again, followed by the [STORE] button.

[MENU]® 2® Password® 3



(Figure 5.3.3-1)

? If the reentered new password in Figure 5.3.3-2 is not correct, the phone is returned to the Figure 5.3.3-1.



(Figure 5.3.3-2)

5.3.4 Phone Info(rmation)

The Phone Information menu displays own number of the phone and the software version.

? Press ;

[MENU]→2→Password→4

? The Figure 5.3.4 is displayed on the screen.

[MENU]® 2® Password® 4

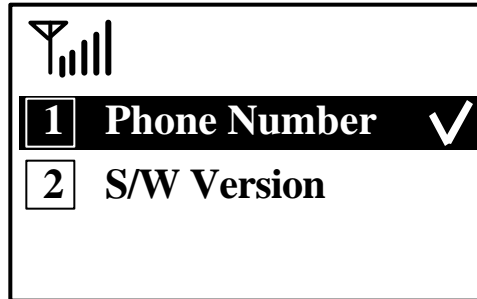

(Figure 5.3.4)

5.3.4.1 Phone Number

? Press the [1] button (Figure 5.3.4) to display own number of a user's phone.

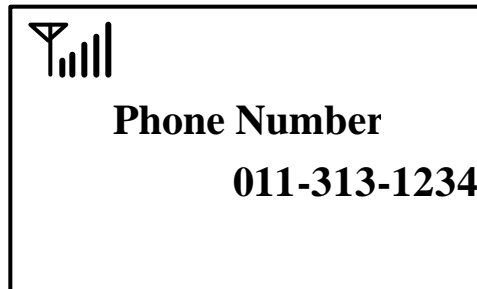

(Figure 5.3.4.1)

5.3.4.2 S/W Version

? Press the [2] button (Figure 5.3.4) and the installed S/W Version in the phone is displayed on the screen.

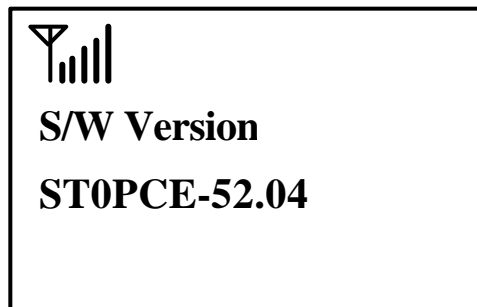

(Figure 5.3.4.2)

5.3.5 Clr Memory

The Clear Memory menu is used to erase the list of last-dialed numbers and the stored numbers in the Phone Book.

? Press;
[MENU] (2 (Password (5

[MENU]® 2® Password® 5

? The Figure 5.3.5 is displayed on the screen.

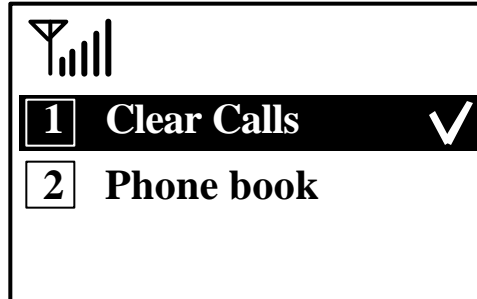

(Figure 5.3.5)

5.3.5.1 Clear calls

? Press the [1] button in Figure 5.3.5 and Figure 5.3.5-1 is displayed.

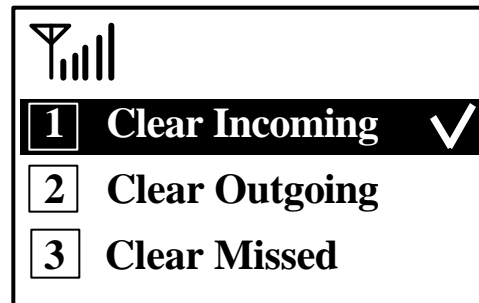

(Figure 5.3.5-1)

5.3.5.1-1 Clear Incoming

? Press;
[MENU] (2 (Password (5 (1 (1

[MENU]® 2® Password® 5® 1® 1

? The Figure 5.3.5-2 is displayed on the screen.

? Using the [?] or [?] button to toggle Yes or No, select Yes to erase the last 10 numbers dialed, followed by the [STORE] button.

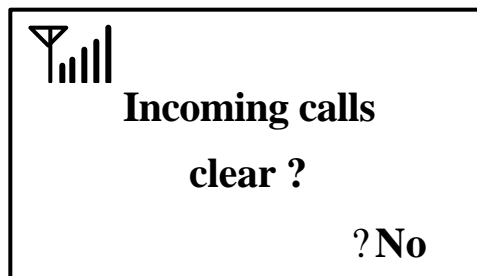

(Figure 5.3.5-2)

5.3.5.1-2 Clear Outgoing

? Press;
[MENU]® 2® Password® 5® 1® 2

[MENU] (2) Password (5) 1 (2)

? The Figure 5.3.5-3 is displayed on the screen.

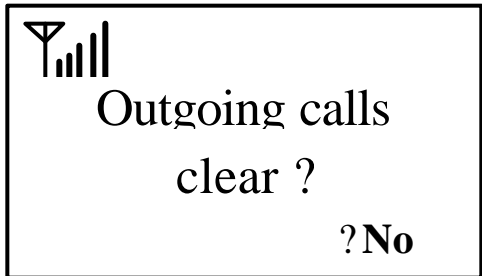

? Using the [?] or [?] button to toggle Yes or No, select Yes to erase the last 10 numbers dialed, followed by the [STORE] button.

(Figure 5.3.5-3)

5.3.5.1-3 Clear Missed

? Press;
[MENU]® 2® Password® 5® 1® 3

[MENU]® 2® Password® 5® 1 (3)

? The Figure 5.3.5-4 is displayed on the screen.

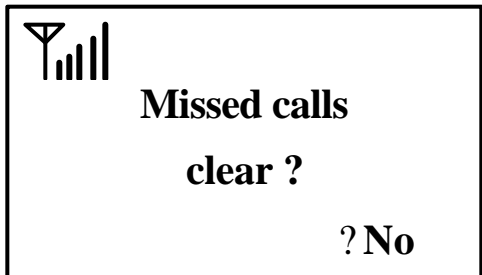

? Using the [?] or [?] button to toggle Yes or No, select Yes to erase the last 10 numbers dialed, followed by the [STORE] button.

(Figure 5.3.5-4)

? To release this function, press the [STORE] button when <Yes> is displayed.

5.3.5.2 (Clr) Phone Book

? If [2] button is pressed in Figure 5.3.5, Figure 5.3.5.2 is displayed on the screen.

? Using the [?] or [?] button to toggle Yes or No, select Yes to erase all the records in the Phone Book, followed by the [STORE] button

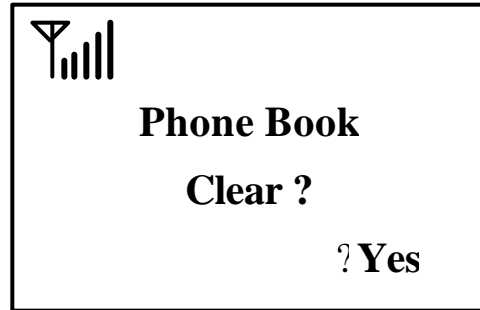

(Figure 5.3.5.2)

5.3.6 Reset Default

The Reset Default menu is used to return the changed functions to the initial status.

? Press;
[MENU] → 2 → Password → 6



? The Figure 5.3.6 is displayed.

? Using the [?] or [?] button to toggle Yes or No, select Yes to start the initializing process, followed by the [STORE] button

? Following this sequence, the power of the phone is turned off and on automatically.

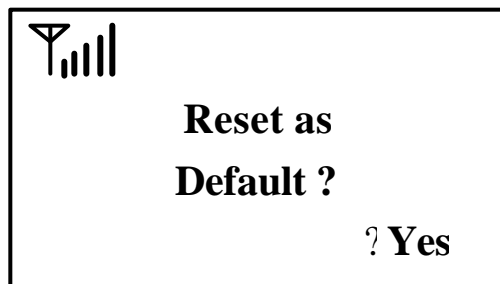

(Figure 5.3.6)

? If the [STORE] button is pressed when “No” is displayed, the phone is returned to the idle-state.

The Check Points when using the Reset As Default Function

When using this function to re-initialize the phone, only the following items will be re-initialized to the default value.

No.	Item	Default Value	Remark
1	Keypad Volume	3 Steps	5.2.3
2	Ringer Volume	3 Steps	5.2.4
3	Ear Volume	3 Steps	5.2.5
4	Speaker Volume	3 Steps	5.2.6
5	Outgoing Lock	No	5.3.2
6	Speed Dial	Enabled	5.4.1
7	Hotline Call	Disabled	5.4.3
8	Timed Hotline Call	6 seconds	5.4.3
9	Voice Privacy	Standard	5.4.4
10	Alert per 1min	Disabled	5.4.5
11	Automatic Dial	Disabled	5.4.6
12	Delay Time for Automatic Dial	6 seconds	5.4.6
13	Dial Time	After 6 seconds	5.4.6
14	Alarm Setting	Off	5.5.1
15	Alarm Time	Hour 00:00	5.5.1

(Table 5.3.6)

5.4 Call Functions

The Call Functions menu is used to set or release some useful call functions

? Press [3] button or use [?] or [?] button in figure 5.1. If Figure 5.4 is displayed, press [STORE] to go to <Call Functions> menu.

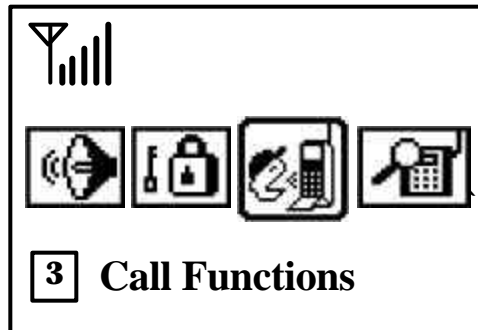

(Figure 5.4)

? With a procedure of Figure 5.4-1



? Press ; [MENU] ® 3

? Figure 5.4-1 and 5.4-2 will be displayed.

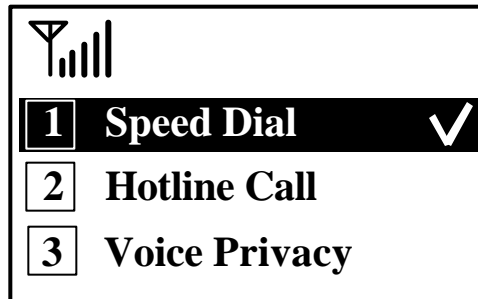

(Figure 5.4-1) Call Functions Menu 1



(Figure 5.4-2) Call Functions Menu 2

5.4.3 Hot-Line Call

This menu is used to release Hot-Line call function.

? Press ; **[MENU] → 3 → 2**

[MENU] ® 3 ® 2

? In order to have a call connected right away with the handset lifted, use [?] or [?] button to have Figure 5.4.3-1 and then press [STORE] button.

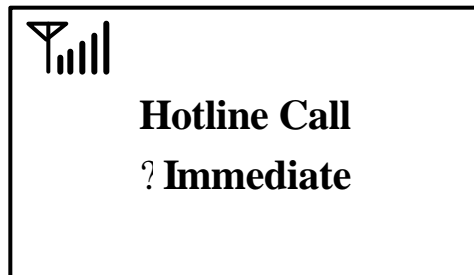

(Figure 5.4.3-1)

? In order to have a call connected in a certain time after the handset is lifted, press [STORE] button if Figure 5.4.3-2 is displayed.

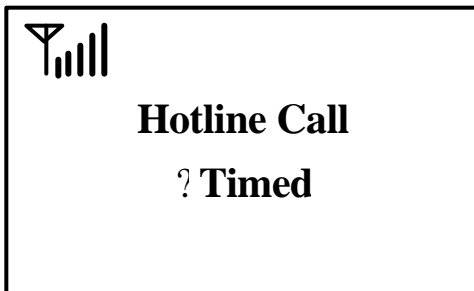

(Figure 5.4.3-2)

? If [STORE] button is pressed again, Figure 5.4.3-3 will be displayed. This is to set the waiting time in Hot Line.

Use the [?] or [?] button to set the desired time and press [STORE] to save.

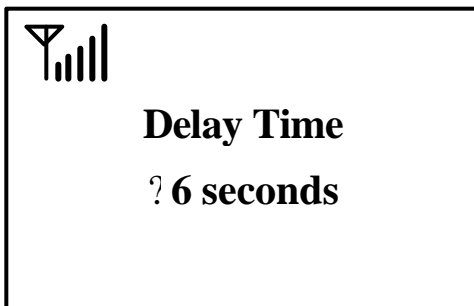

(Figure 5.4.3-3)

The time setting ranges from 4 to 8 seconds.

For more information on Hot Line function, refer to chapter 3.6 Hot Line.

5.4.4 Voice Privacy

The Voice Privacy menu is used to set or release the privacy function and offers protection from illegal wiretapping.

? In Figure 5.4, if the [4] button is pressed, Figure 5.4.4-1 is displayed on the screen.

[MENU] ® 3 ® 3

? Press ; .[MENU] → 3 → 3

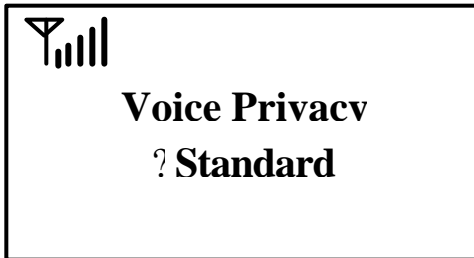

? After pressing the [STORE] button, the phone is in the normal privacy mode and the phone sends the voice in this privacy mode.

(Figure 5.4.4-1)

? Press [?] or [?] button, and Figure 5.4.4-2 is displayed on the screen.



? Press [STORE] button to have the phone send the voice in the enhanced privacy mode to block the wiretapping.

(Figure 5.4.4-2)

5.4.5 Alert per 1 Min

The Alert per 1 Min menu is used to set or release an alert sound every 1-minute during the call.

? Press ; [MENU] ® 3 ® 4

[MENU] ® 3 ® 4

The Figure 5.4.5 is displayed on the screen.

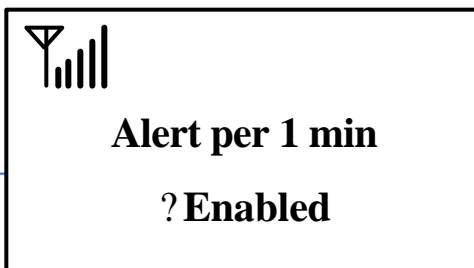

(Figure 5.4.5)

? Select the “Yes” or “No” menu using the [?] or [?] button, followed by the [STORE] button.

5.4.6 Automatic Dial

The Automatic Dial menu is used to make an automatic call within a set time even if the [SND/RDL] button is not pressed after dialing the number.

? Press ; **[MENU] ® 3 ® 5**

[MENU] ® 3 ® 5

? The Figure 5.4.6-1 is displayed on the screen.

? Select the “Yes” or “No” menu using the [?] or [?] button, followed by the [STORE] button.

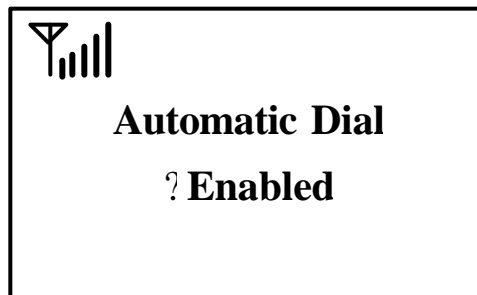

(Figure 5.4.6-1)

? Select the “Yes” menu, and Figure 5.4.6-2 is displayed on the screen.

? Select the desired time using the [?] or [?] button, followed by the [STORE] button.

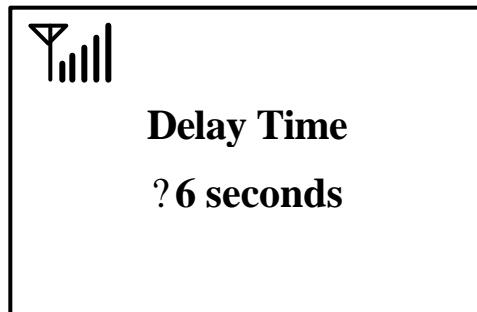

(Figure 5.4.6-2)

5.5 Additional (Features)

The Additional Functions menu is used to set the Alarm Function and the Data Receive Mode when using the data service utilizing the PC.

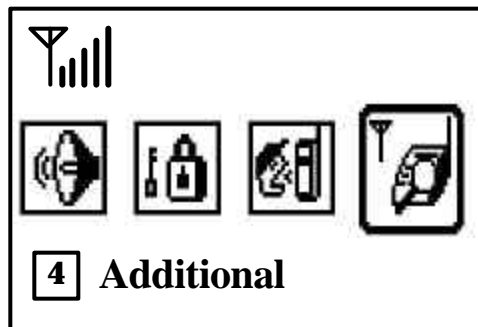

(Figure 5.5)

? Press ; **[MENU]** ® 4



? Press [4] button or use [?] or [?] button in Figure 5.1, and Figure 5.5-1 will be displayed.

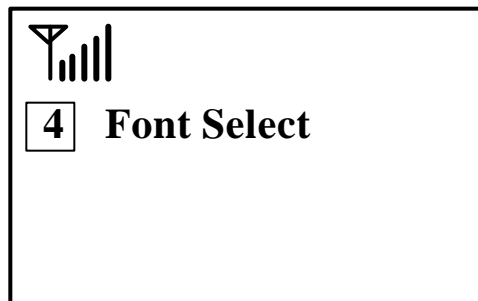
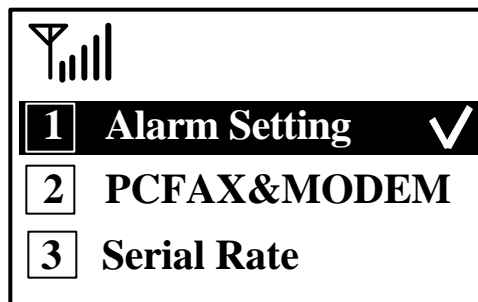

(Figure 5.5-1)

5.5.1 Alarm Setting

The Alarm Setting menu is used to set the alarm function and the alarm time to the on/off positions.

? In Figure 5.5, press [1] button to set the alarm time.



? Press ; [MENU] → 4 ® 1

The Figure 5.5.1-1 is displayed on the screen.

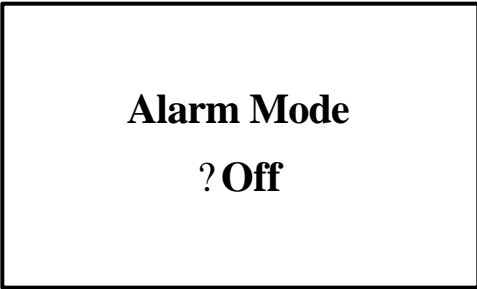

(Figure 5.5.1-1)

The default value is “Off” and to change it to “Only Once” or “Always” mode use [?] or [?] button.

? When Figure 5.5.1-2 is shown, press [STORE] button to set “Only Once” mode and the alarm will work only one time at the entered time.

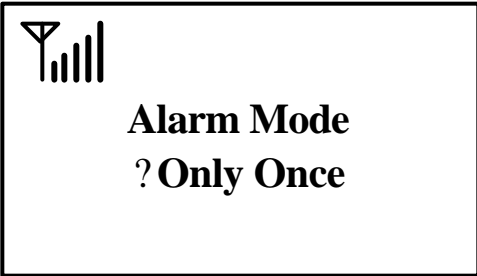

(Figure 5.5.1-2)

? When Figure 5.1.1-3 is displayed, press [STORE] to set “Always” mode and the alarm will work every single day at the entered time.

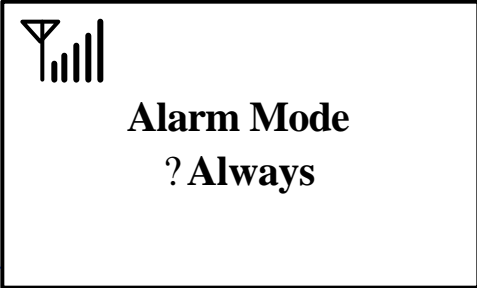

(Figure 5.5.1-3)

? After setting the alarm mode, Figure 5.5.1-4 will be displayed to indicate the alarm time.

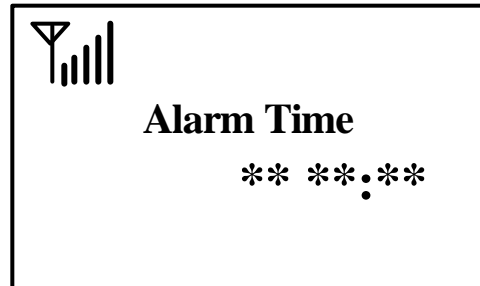

(Figure 5.5.1-4)

[Reference]

In case of the incorrect setting, press [CLR] button, then the time set is erased in reverse order.

5.5.2 PC FAX & MODEM

The PC Fax & Modem menu is used to set the phone to data receive mode when using Data Service to receive a facsimile to PC or when communicating to PC.

? In Figure 5.5, press [2] button and Figure 5.5.2-1 will be displayed.



Press ; [MENU] ® 4 ® 2

? The Figure 5.5.2-1 is displayed on the screen.

? After pressing the [STORE] button, the voice-call mode is set.

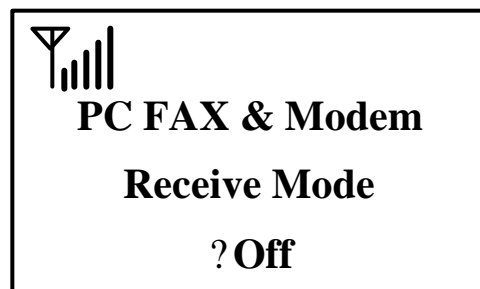

(Figure 5.5.2-1)

? To reach Figure 5.5.2-2 using the [?] or [?] button in the Figure 5.5.2-1, press the [STORE] button.

? The phone will remain in the Modem Receive Mode.

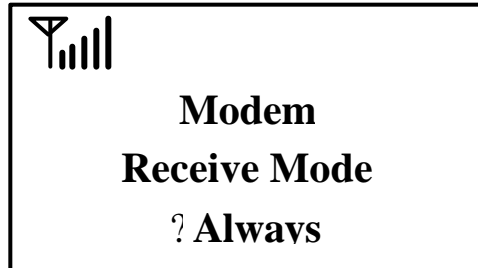

(Figure 5.5.2-2)

? To reach Figure 5.5.2-3 using the [?] or [?] button in the Figure 5.5.2-1, press the [STORE] button.

? In this case the phone will stay in the Modem Receive Mode one time and will subsequently return to the voice-call mode.

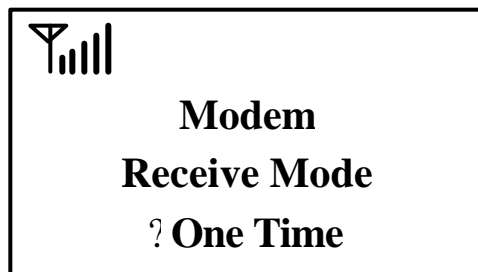

(Figure 5.5.2-3)

? To reach Figure 5.5.2-4 using the [?] or [?] button in the Figure 5.5.2-1, press the [STORE] button.

? In this case, the phone will always stay in the PC Fax Receive Mode.

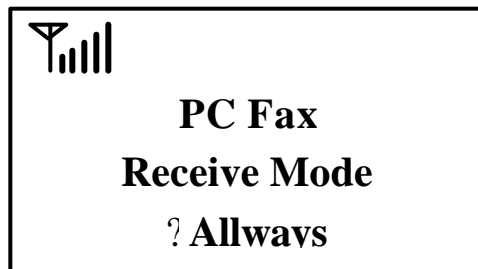

(Figure 5.5.2-4)

? To reach Figure 5.5.2-5 using the [?] or [?] button in the Figure 5.5.2-1, press the [STORE] button.

? The phone works in the PC Fax Receive Mode once and will subsequently return to the voice-call mode.

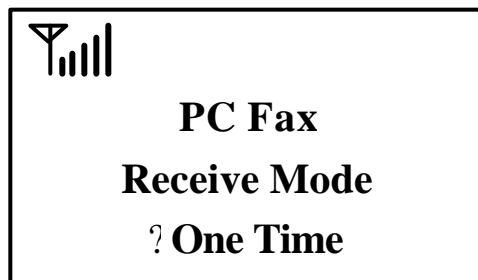

(Figure 5.5.2-5)

? When the phone is set in the PC Fax Receive Mode, the PC Fax Receive Mode Icon is displayed.

? When the phone is set in the Modem receive Mode, the Modem Receive Mode Icon(2.3.7) is displayed.

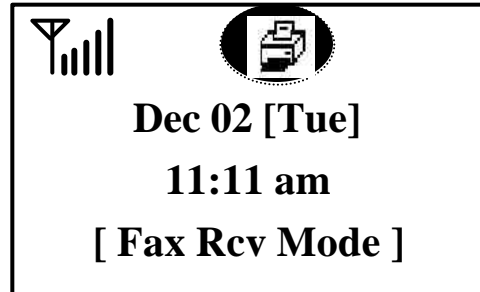

(Figure 5.5.2-6)

5.5.3 Serial Rate

This is about operating the menu to show the interface speed setting between a phone and a PC.

? Press ; **[MENU] ® 4 ® 3**

? Using the [?] or [?] button, select desired data rate in the following options.

- 19,200 bps
- 115,200 bps

And then, press **[STORE]** button.
(Figure 5.5.3)

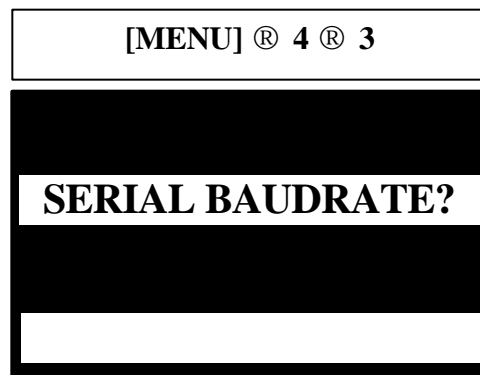

[Reference]

The default value is 115,200bps. If other Baud Rate is set and the phone turns off and on, the Baud Rate of this phone will be automatically set as 115,200bps and the setting for the desired Baud Rate is required again.

5.5.4 Font Select

This phone model supplies 2 types of text fonts. The Font Select menu is used to select the text font displayed on the LCD. The default text font is in “Ming style”. is “Gothic style”.

? Press ; **[MENU] ® 4 ® 4**

? Using the [?] or [?] button, select the font, followed by the [STORE] button.

? The phone returns to the idle-state and displays the changed text font.

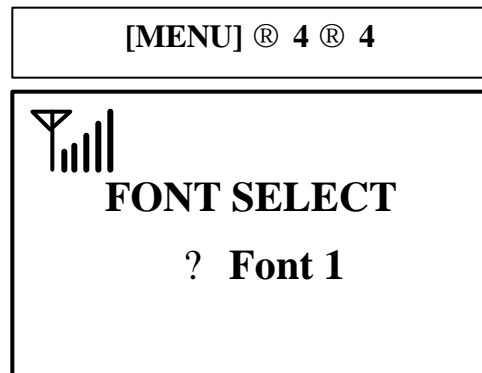

(Figure 5.5.4)

Appendix A: Troubleshooting

Problems	Remedy
No display of the phone at all.	<ul style="list-style-type: none">-Check and see if the power supply is connected properly and in a good manner.- Check if power switch is turned on.
Mal-operation while in use or no operation	<ul style="list-style-type: none">- Turn off and on of the power switch at the backside of the phone and if the same symptom occurs, contact the service center.
“No Service” is displayed on the screen	<ul style="list-style-type: none">-Wait for 2 minutes after the power is turned on.- Move the phone to another location.- Adjust the antennas direction.
No voice from the handset	<ul style="list-style-type: none">-Check the connection cable between the phone and handset.- Adjust the speaker volume or handset volume
A caller is able to hear called party, but a called party is unable to hear the voice of a calling party	<ul style="list-style-type: none">- Check the connection cable between the phone and handset.
The phone does not ring when a call is received.	<ul style="list-style-type: none">- Adjust the ringer volume.
Long distance call or the overseas call does not work	<ul style="list-style-type: none">- Check the menu setup.
Voice call works but Data Service does not work	<ul style="list-style-type: none">- Check the PC setup in Data Service Manual.

If the same problem persists, consult the nearest service center.

Appendix B: Specifications

Item		Phone Type	
Size (W* D * H mm)		170* 190* 80 mm	
Weight (g)		1000 (Including Backup Battery)	
Talk Time		2 Hrs more	
Standby Time		50 Hrs (-85dBm, slot mode2)	
Frequency Range		Tx: 824~849MHz,1850~1910MHz Rx: 869~894MHz,1930~1990MHz	
Frequency Accuracy		±300 Hz / ±150 Hz	
Bandwidth		1.25MHz	
Main Processor		Qualcomm MSM5000	
Max Data Transmission		153 kbps	
Input Power		90~270VAC, 48~62 Hz	
Output Power		DC <u>12V@1A</u>	
Operating Temperature		0~50?	
Battery		Ni-Cd	
Features	LED		Speaker Phone
	LCD		4Line 16Column
	Air Interface		IS-95C, Backword Compatible
	Vocoder		8K/13K QCELP, 8K EVRC
	Receiver Volume Control		5 Levels
	Max REN Load	US STD Phone	5 Sets
		European STD Phone	3 Sets
	Caller ID Presentation		Available (LCD Display)
	PCO		Optional
	Hook Flash Function		Available
	Dial tone at off-Hook		Available
	Ringer Frequency Selection		10 Tone & Melody
	ON/OFF Time Selection		6 items
	Dial Tone Selection		4 items
	ANT		Dipole Antenna
	External ANT		Directional Pane ANT(Optional)

Safety Information

1 . SAFETY INFORMATION FOR FIXED WIRELESS TERMINALS

.POTE NTIALLY EXPLOSIVE ATMOSPHERES

Turn your phone OFF when in any area with a potentially explosive atmosphere and obey all signs and instructions. Sparks in such areas could cause an explosion or fire resulting in bodily injury or even death.

.INTERFERENCE TO MEDICAL DIVICES

Certain electronic equipment may be shielded against RF signal from you wireless phone. (pacemakers, Hearing Aids, and so on)

Turn your phone OFF in health care facilities when any regulations posted in these areas instruct you to do so.

RF signals may affect improperly installed or inadequately shielded electronic system in motor vehicles.

.EXPOSURE TO RF ENERGY

Use only the supplied or an approved replacement antenna.

Do not touch the antenna unnecessarily when the phone is in use.

Do not move the antenna close to, or touching any exposed part of the body when making a call.

SAR INFORMATION

THIS MODEL PHONE MEETS THE GOVERNMENT 'S REQUIREMENTS FOR EXPOSURE TO RADIO WAVES.

Your wireless phone is a radio transmitter and receiver. It is designed and manufactured not to exceed the emission limits for exposure to radio frequency (RF) energy set by the Federal Communications Commission of the U.S. Government. These limits are part of comprehensive guidelines and establish permitted levels of RF energy for the general population. The guidelines are based on standards that were developed by independent scientific organizations through periodic and thorough evaluation of scientific studies. The standards include a substantial safety margin designed to assure the safety of all persons, regardless of age and health.

The exposure standard for wireless mobile phones employs a unit of measurement known as the Specific Absorption Rate, or SAR. The SAR limit set by the FCC is 1.6 W/kg. *Tests for SAR are conducted with the phone transmitting at its highest certified power level in all tested frequency bands. Although the SAR is determined at the highest certified power level, the actual SAR level of the phone while operating can be well below the maximum value. This is because the phone is designed to operate at multiple power levels so as to use only the power required to reach the network. In general, the closer you are to a wireless base station antenna, the lower the power output. Before a phone model is available for sale to the public, it must be tested and certified to the FCC that it does not exceed the limit established by the government-adopted requirement for safe exposure.

The tests are performed in positions and locations (e.g., at the ear and worn on the body) as required by the FCC for each model. The highest SAR value for this model phone when worn on the body, as described in this user guide, is **0.861 W/kg**. (Body worn measurements differ among phone models, depending upon available accessories and FCC requirements). While there may be differences between the SAR levels of various phones and at various positions, they all meet the government requirement for safe exposure. The FCC has granted an Equipment Authorization for this model phone with all reported SAR levels evaluated as in compliance with the FCC RF exposure guidelines. SAR information on this model phone is on file with the FCC and can be found under the Display Grant section of [http://www.fcc.gov / oet / fccid](http://www.fcc.gov/oet/fccid) after searching on **[FCC ID : PV4WS-4000](#)**.

Additional information on Specific Absorption Rates (SAR) can be found on the Cellular Telecommunications & Internet Association (CTIA) web-site at <http://phonefacts.net>. *In the United States and Canada, the SAR limit for mobile phones used by the public is 1.6 watts/kg (W/kg) averaged over one gram of tissue. The standard incorporates a substantial margin of safety to give additional protection for the public and to account for any variations in measurements.

FCC RF EXPOSURE INFORMATION

In August 1996 the Federal Communications Commission (FCC) of the United States with its action in Report and Order FCC 96-326 adopted an updated safety standard for human exposure to radio frequency (RF) electromagnetic energy emitted by FCC regulated transmitters. Those guidelines are consistent with the safety standard previously set by both U.S. and international standards bodies. The design of this phone complies with the FCC guidelines and these international standards.

To comply with FCC RF exposure requirements, a minimum separation distance of **2.5cm (0.98 inch)** must be maintained between the user/ bystander and the back of the unit, including the antenna.

For more information about RF exposure, please visit the FCC website at www.fcc.gov

WARNING! Read this information before use

FCC Compliance Information

This device complies with Part 15 of FCC Rules.
Operation is subject to the following two conditions:

- (1) This device may not cause harmful interference, and
- (2) This device must accept any interference received.
Including interference that may cause undesired operation.

Information to User

This equipment has been tested and found to comply with the limits for a Class B digital device, pursuant to part 15 of the FCC Rules. These limits are designed to provide reasonable protection against harmful interference in a residential installation. This equipment generates, uses and can radiate radio frequency energy and, if not installed and used in accordance with the instructions, may cause harmful interference to radio communications. However, there is no guarantee that interference will not occur in a particular installation. If this equipment does cause harmful interference to radio or television reception, which can be determined by turning the equipment off and on, the user is encouraged to try to correct the interference by one or more of the following measures:

- Reorient or relocate the receiving antenna.
- Increase the separation between the equipment and receiver.
- Connect the equipment into an outlet on a circuit different from that to which the receiver is connected.
- Consult the dealer or an experienced radio/ tv technician for help.