

Trace L Antenna on a 62 mm wide x 64 mm long x 0.813 mm thick PCB with metal screws:

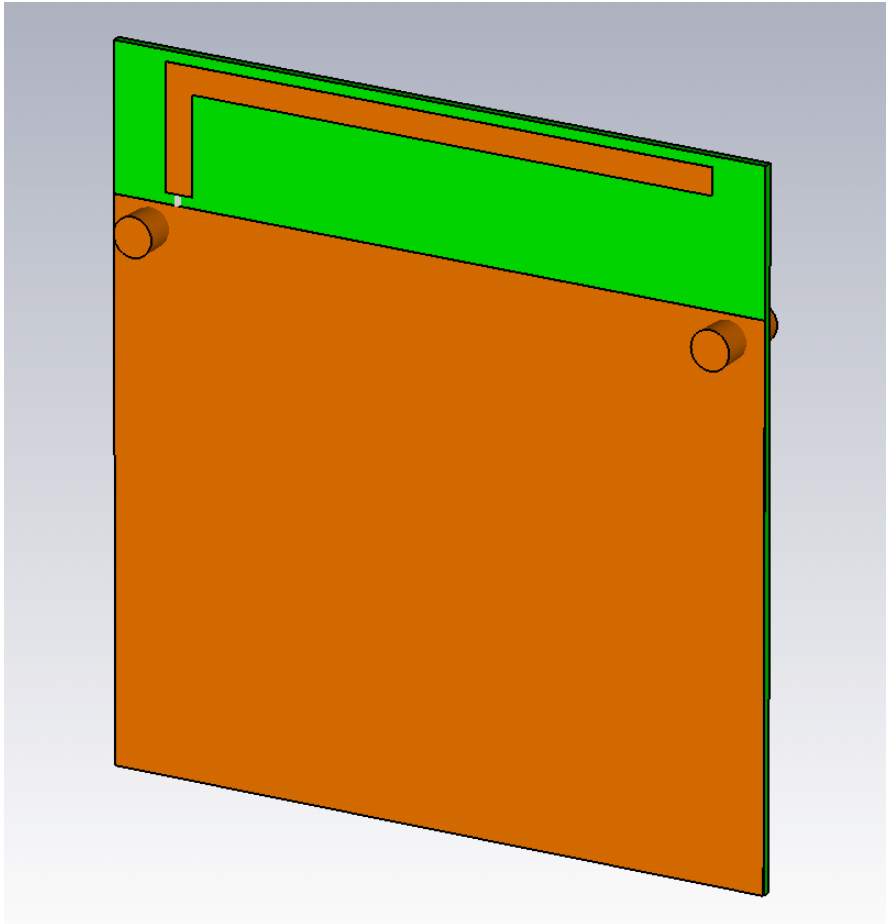

Impedance Matching:

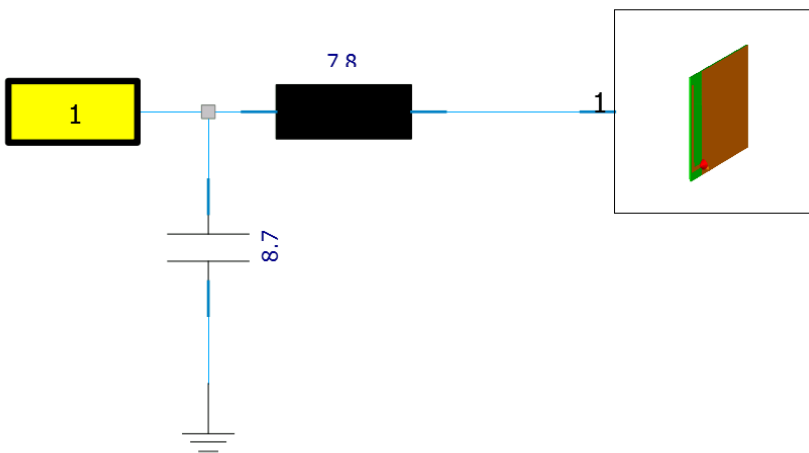

Input Reflection Coefficient:

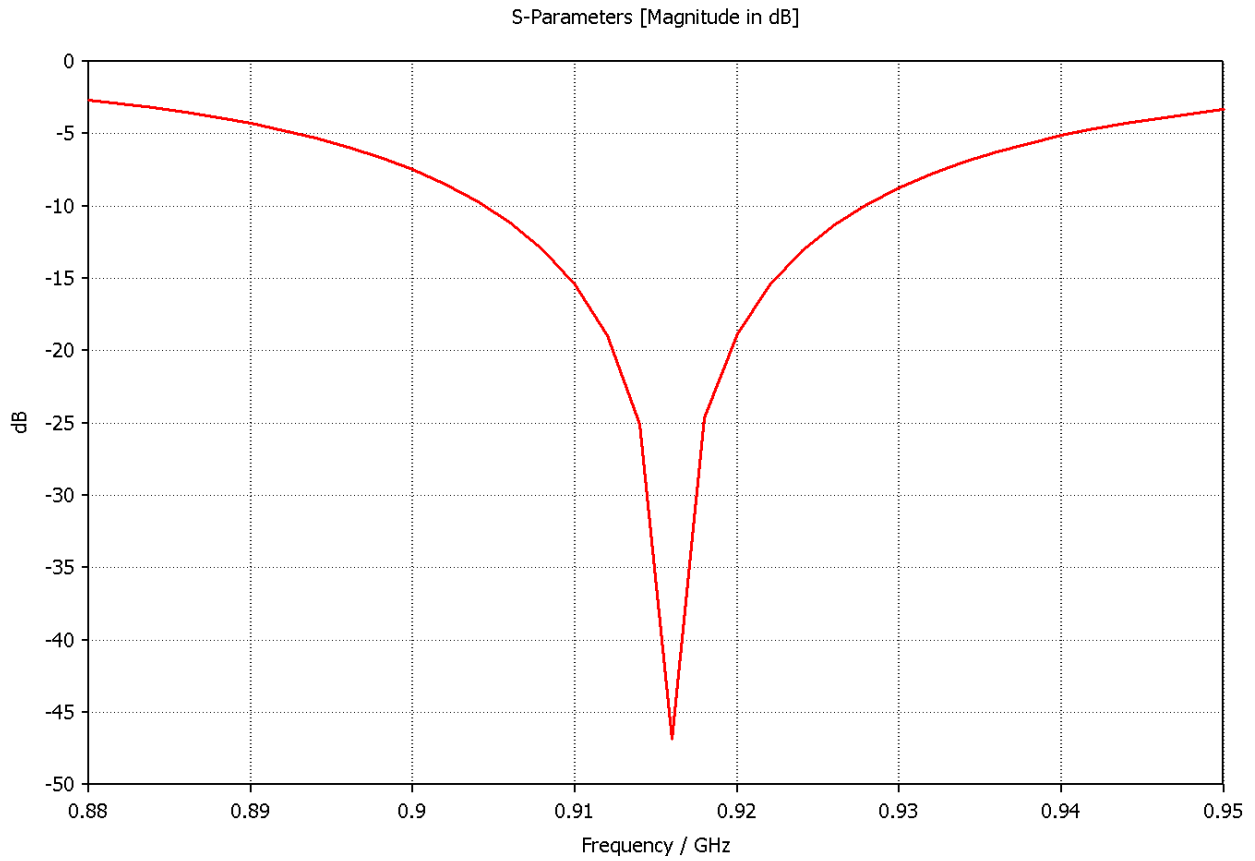

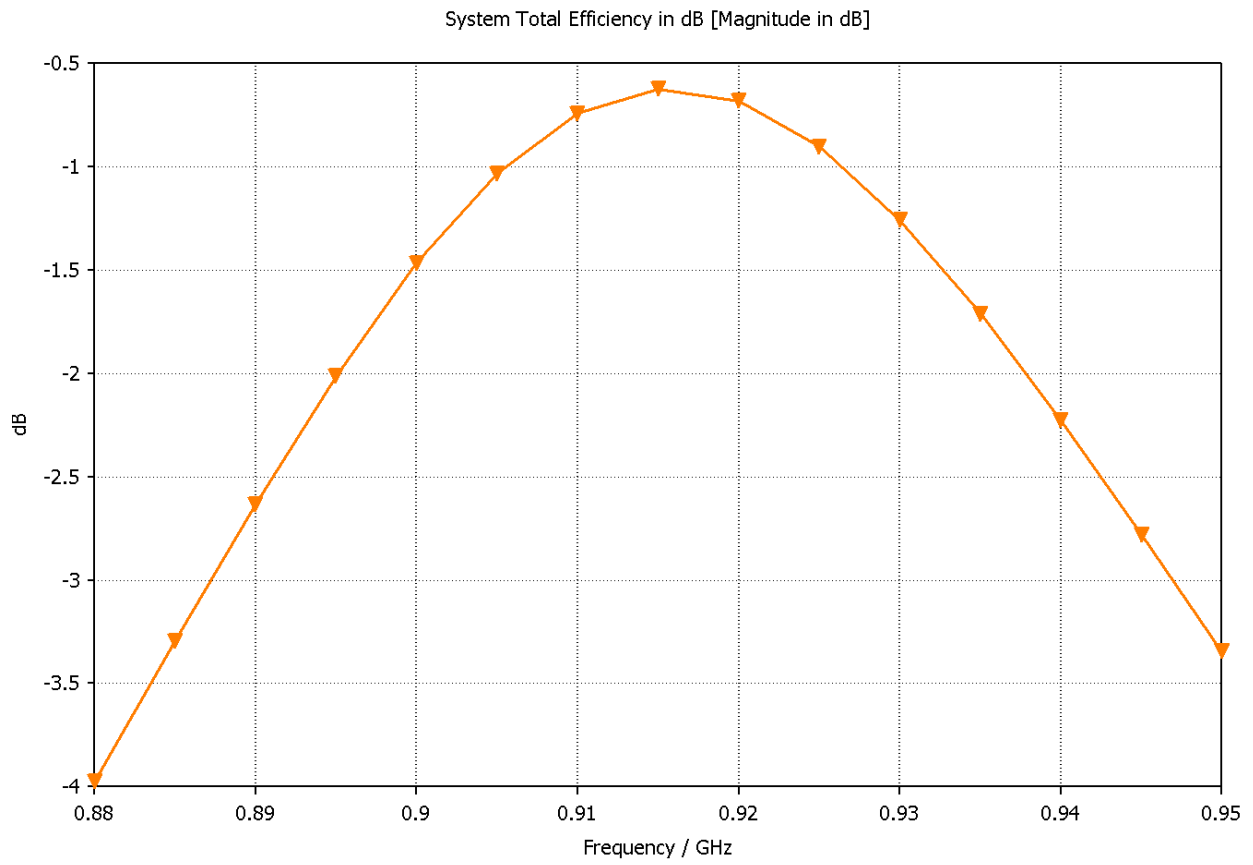

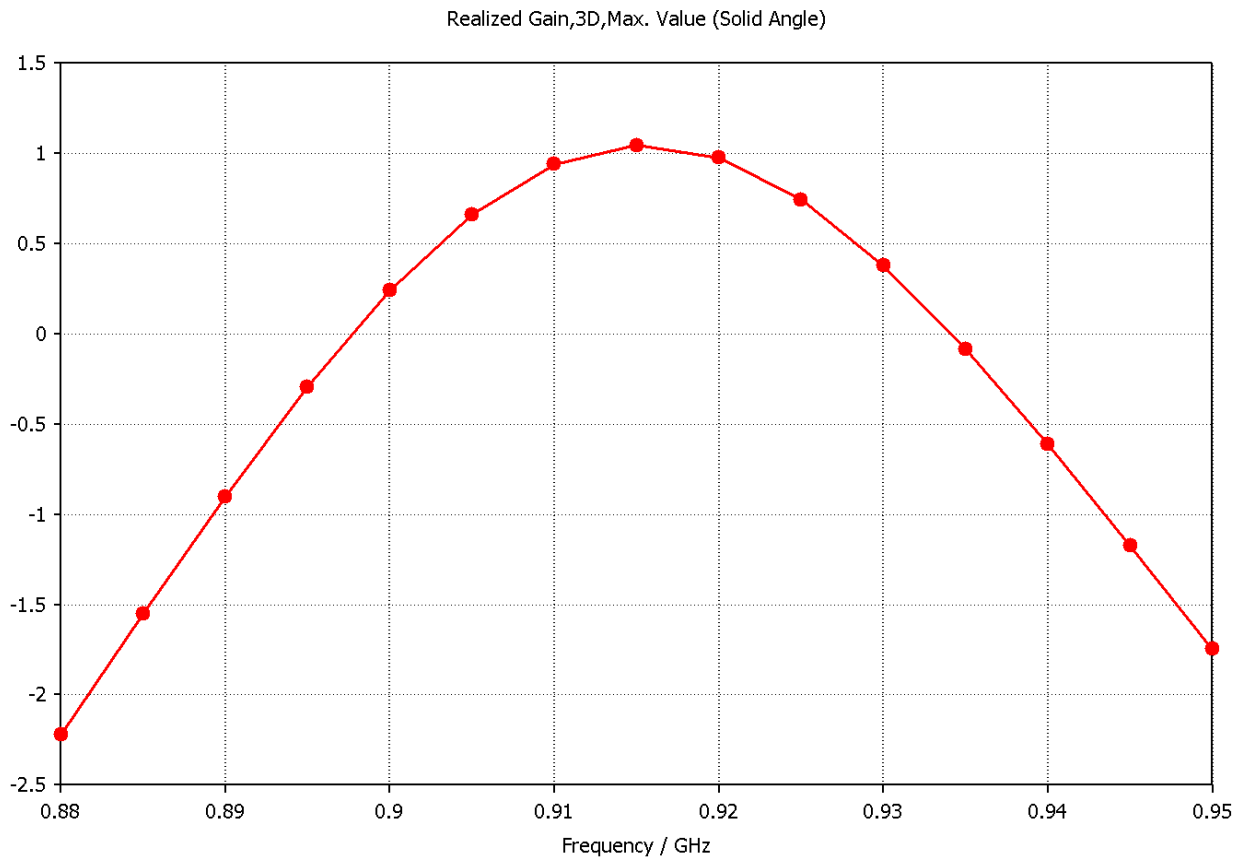

Total Gain:

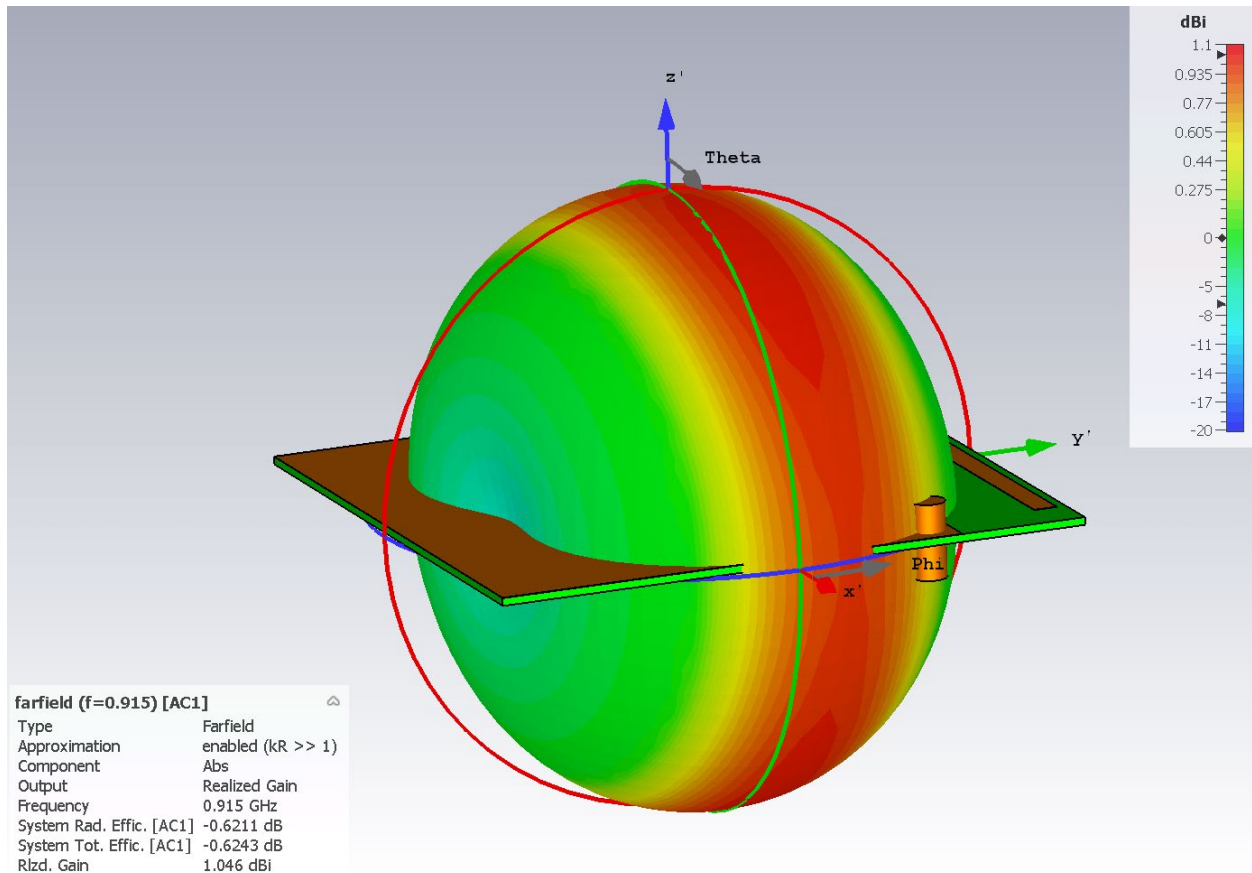

Total Gain (rotated about the z' axis):

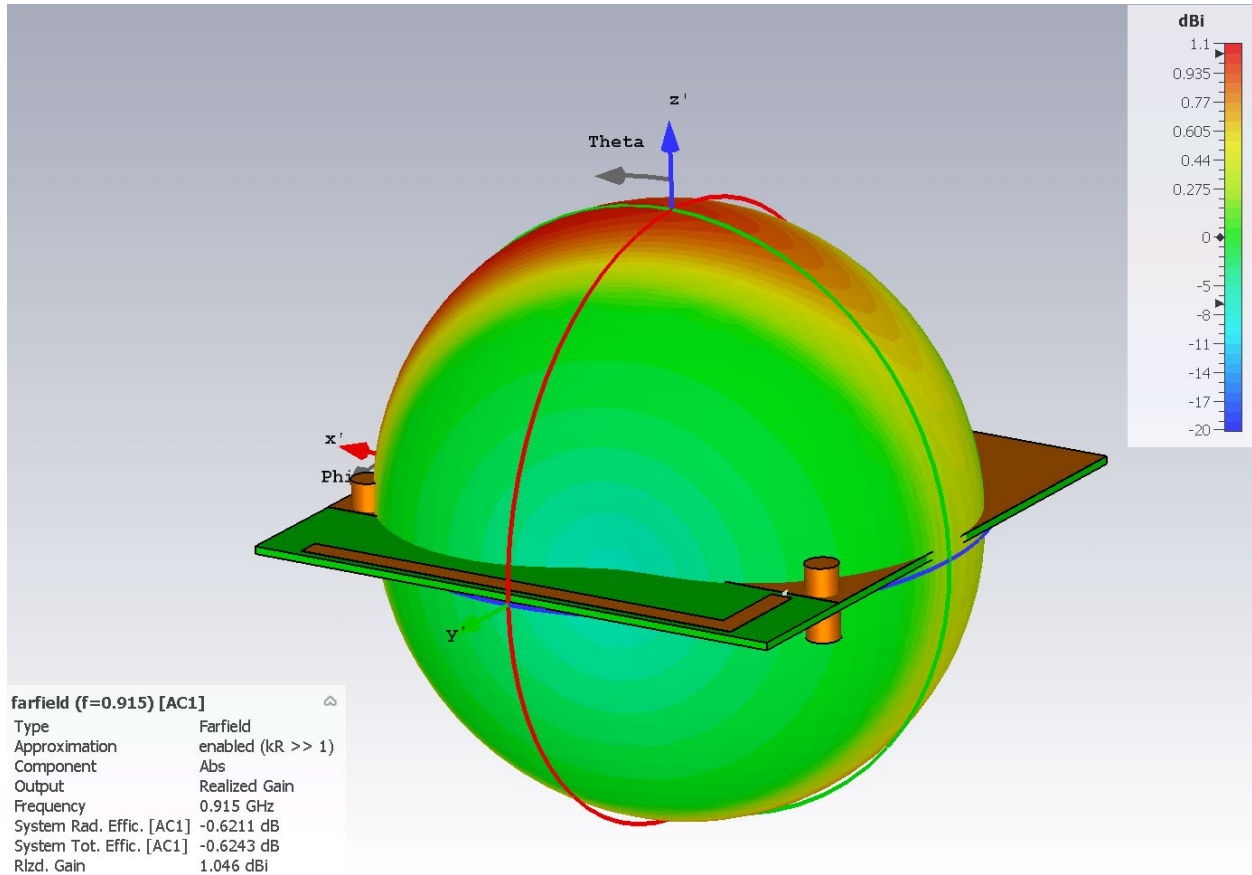

Gain, Phi Polarization:

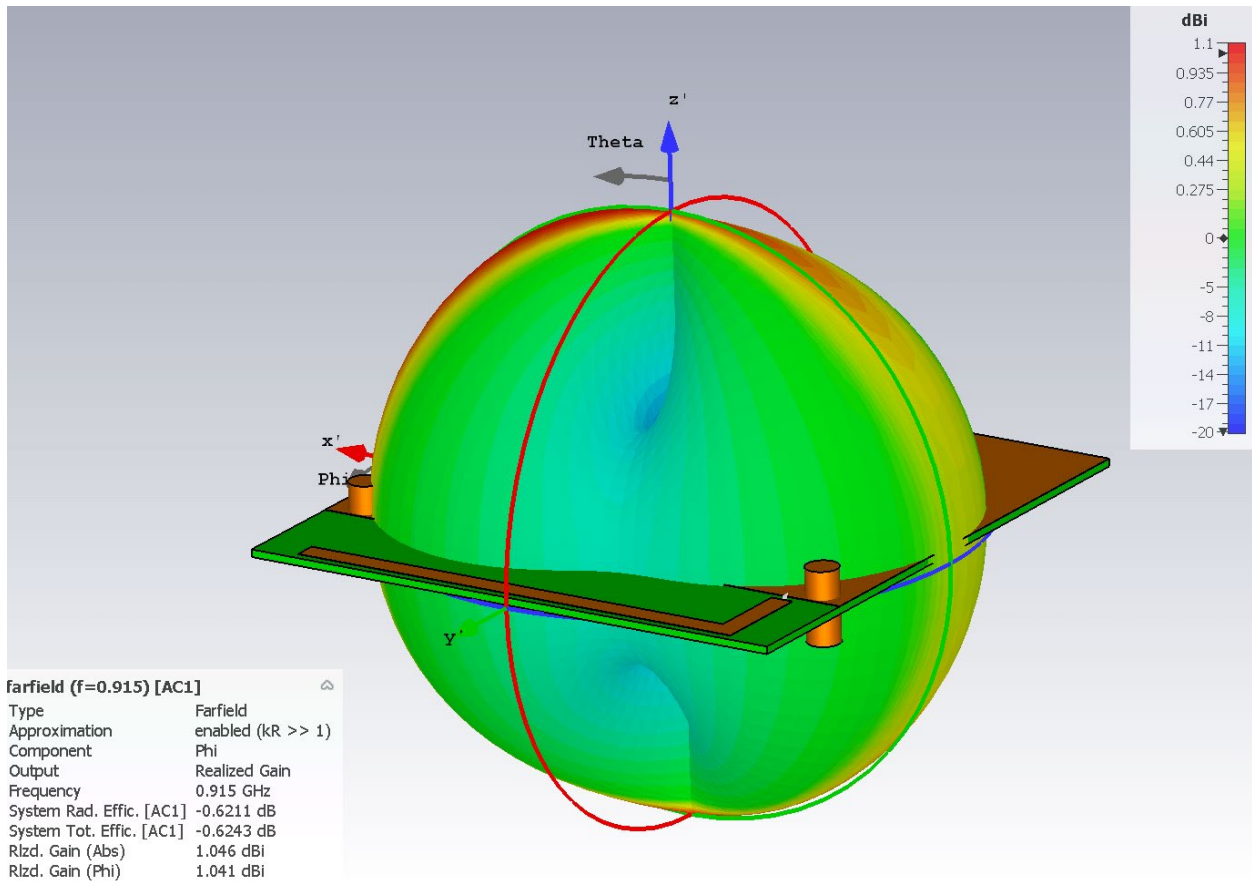

Gain, Theta Polarization:

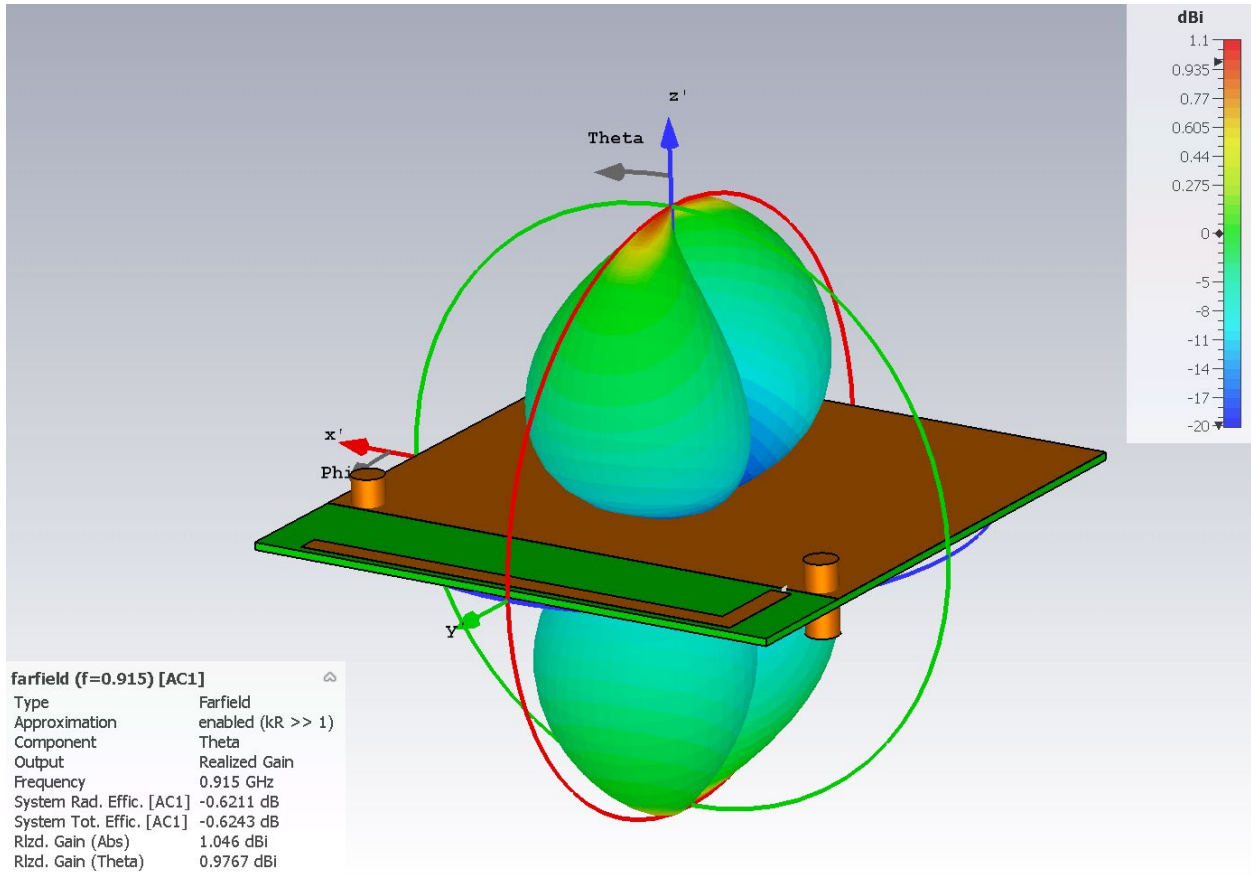



x-y plane (Theta = 90 degrees), Phi Polarization:

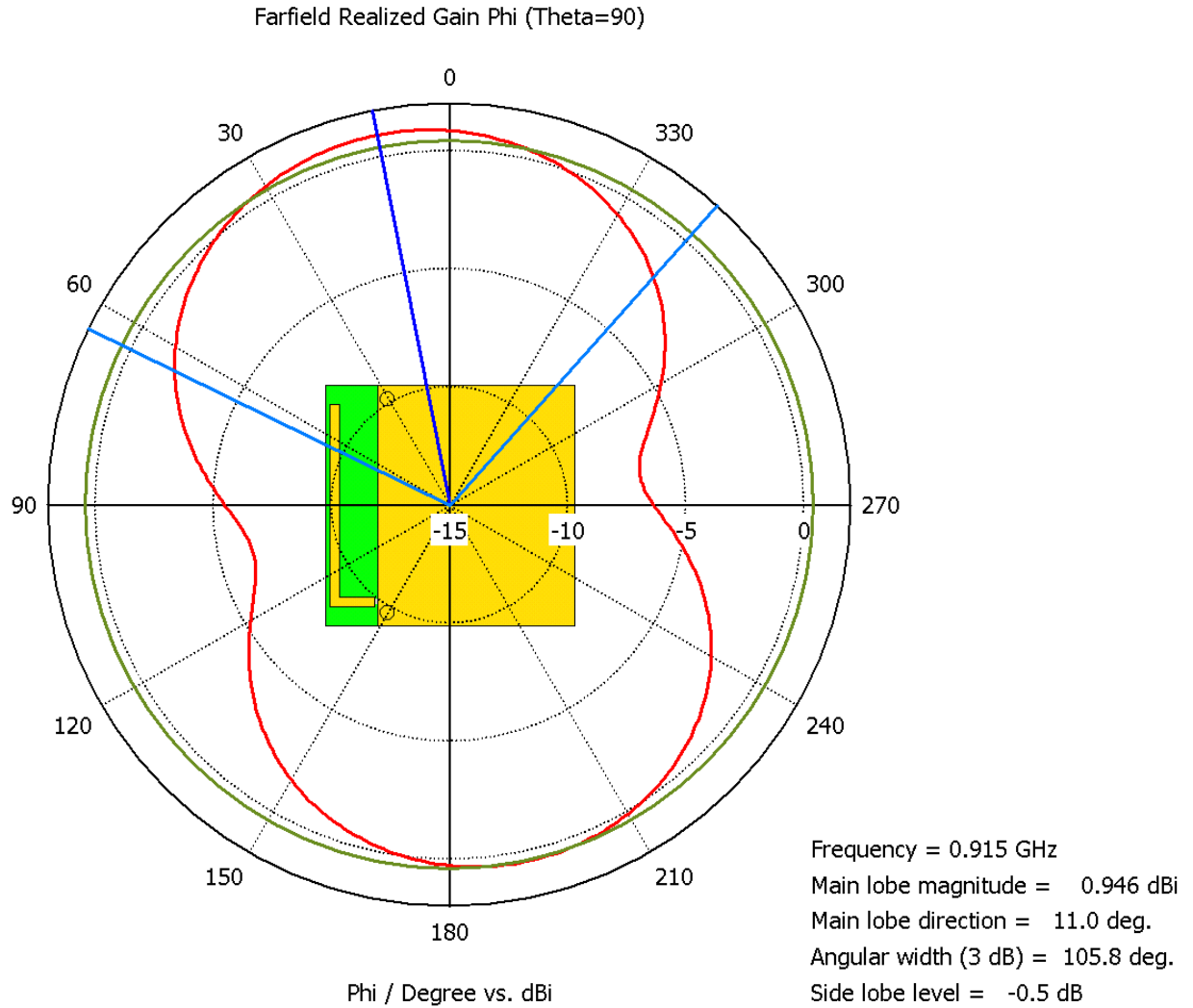

x-y plane (Theta = 90 degrees), Theta Polarization (none):

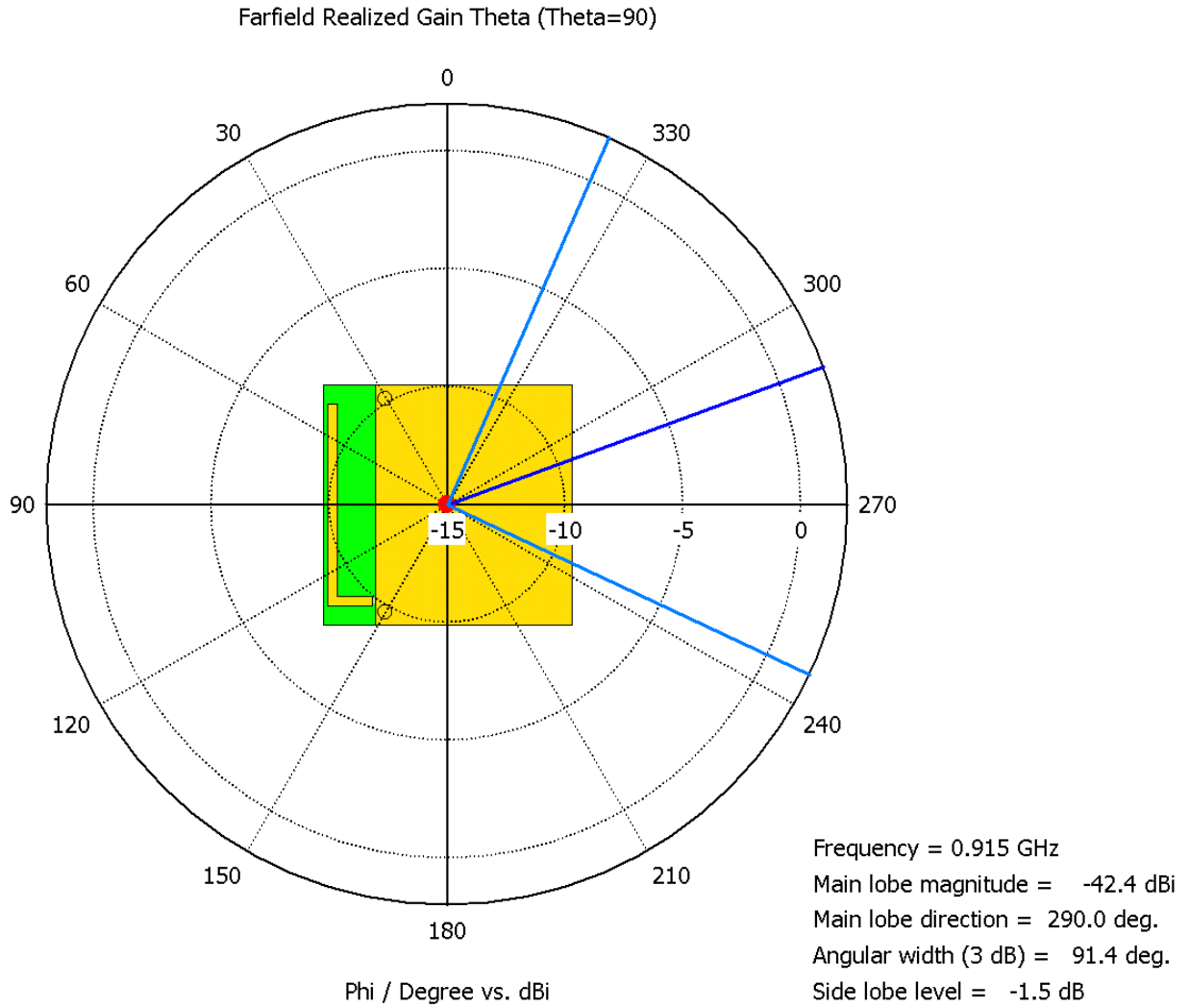

x-z plane (Phi = 0 degrees), Phi Polarization:

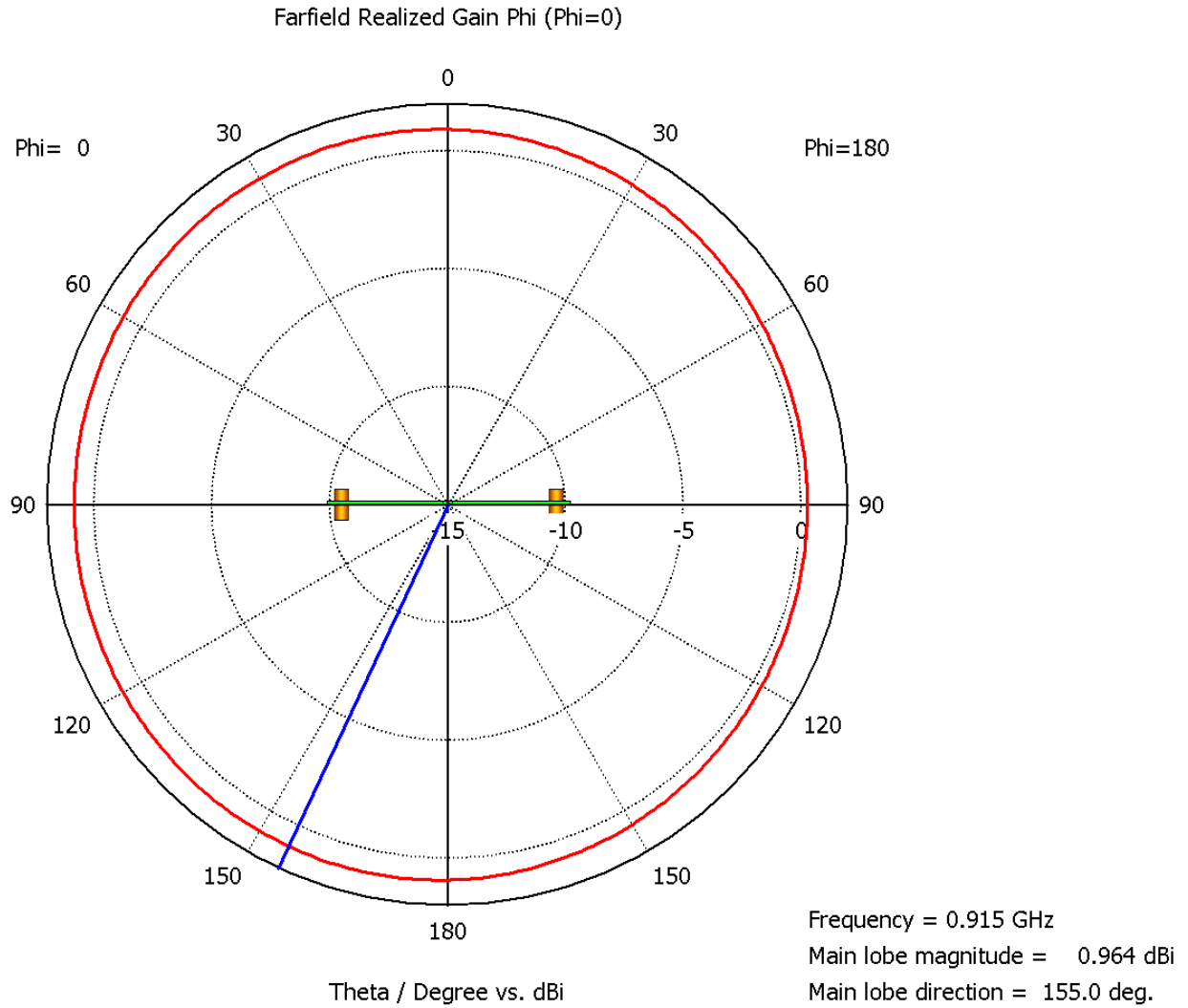

x-z plane (Phi = 0 degrees), Theta Polarization:

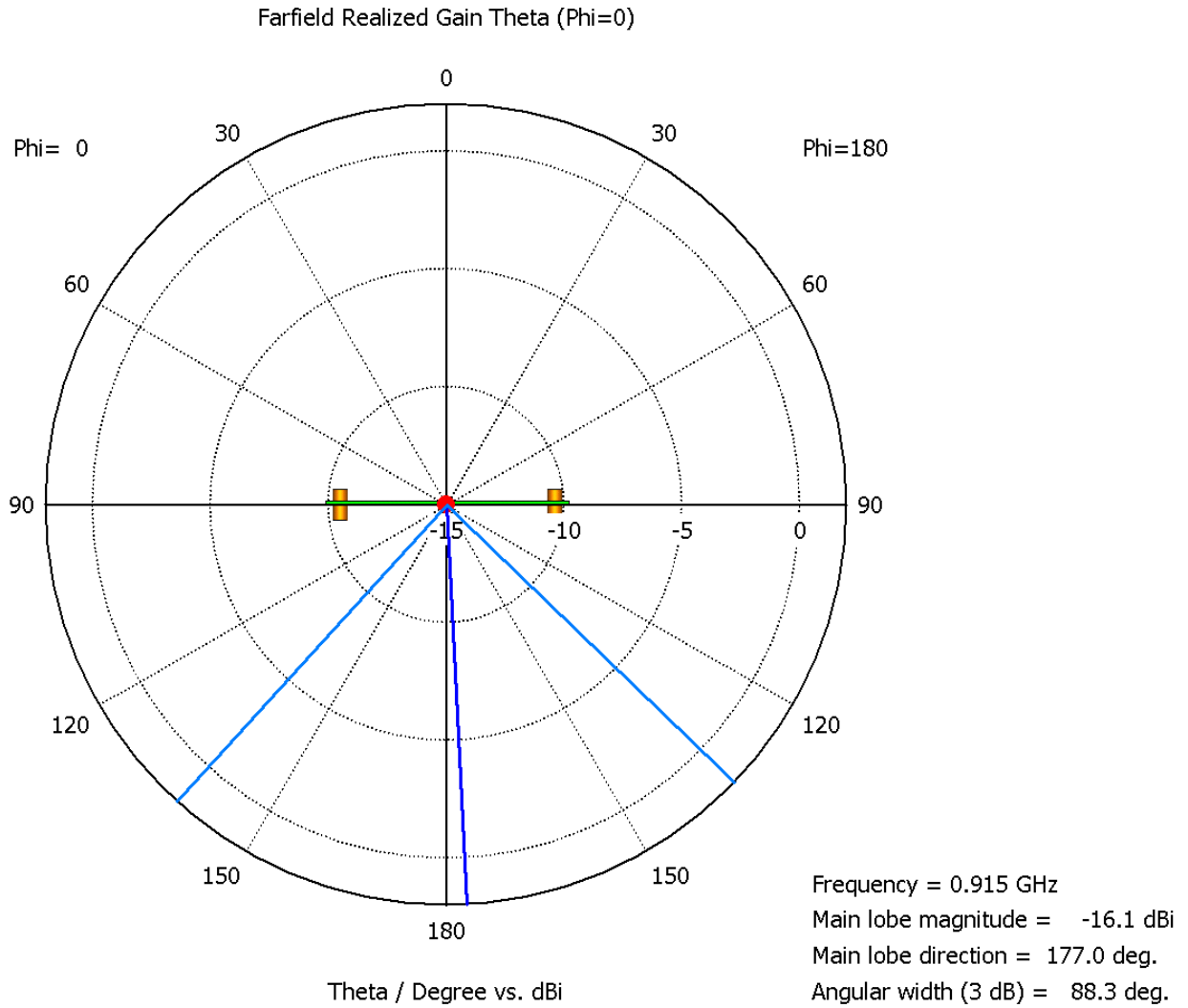

y-z plane (Phi = 90 degrees), Phi Polarization:

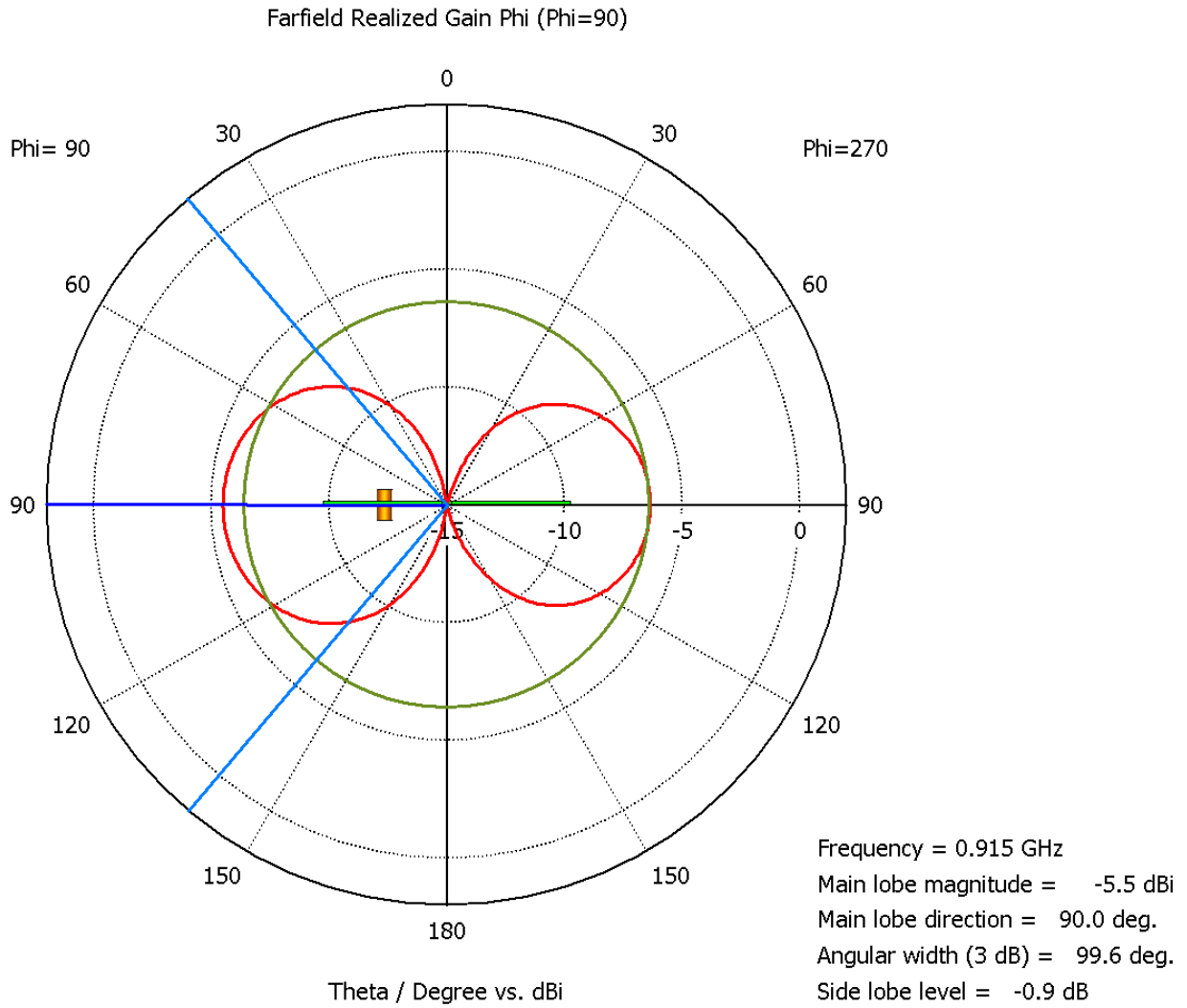

y-z plane (Phi = 90 degrees), Theta Polarization:

