



849 NW STATE ROAD 45  
NEWBERRY, FL 32669 USA  
PH: 888.472.2424 OR 352.472.5500  
FAX: 352.472.2030  
EMAIL: [INFO@TIMCOENGR.COM](mailto:INFO@TIMCOENGR.COM)  
[HTTP://WWW.TIMCOENGR.COM](http://WWW.TIMCOENGR.COM)

**FCC PART 90**  
**CLASS II PERMISSIVE CHANGE**  
**TEST REPORT**

APPLICANT	SUMMATION RESEARCH INC.
	3950 DOW ROAD
	MELBOURNE FL 32934-9215 USA
FCC ID	OQW-STR1820
MODEL NUMBER	STR-1820
PRODUCT DESCRIPTION	LAND MOBILE UHF RADIO FOR DATA COMMUNICATIONS
DATE SAMPLE RECEIVED	1/14/2011
DATE TESTED	2/8/2011
TESTED BY	JOSEPH SCOGLIO
APPROVED BY	MARIO R. DE ARANZETA
TIMCO REPORT NO.	108UT11TestReport.doc
TEST RESULTS	<input checked="" type="checkbox"/> PASS <input type="checkbox"/> FAIL

**THE ATTACHED REPORT SHALL NOT BE REPRODUCED EXCEPT IN FULL WITHOUT THE WRITTEN APPROVAL OF TIMCO ENGINEERING, INC.**



Certificate # 0955-01



## TABLE OF CONTENTS

GENERAL REMARKS.....	3
GENERAL INFORMATION .....	4
EQUIPMENT LIST.....	5
TEST PROCEDURE .....	6
OTHER MODULATION CHARACTERISTICS.....	7
OCCUPIED BANDWIDTH.....	8
OCCUPIED BANDWIDTH PLOTS.....	10

## GENERAL REMARKS

The attached report shall not be reproduced except in full without the written permission of Timco Engineering Inc.

## Summary

The device under test does:

- fulfill the general approval requirements as identified in this test report  
 not fulfill the general approval requirements as identified in this test report

## Attestations

This equipment has been tested in accordance with the standards identified in this test report. To the best of my knowledge and belief, these tests were performed using the measurement procedures described in this report.

All instrumentation and accessories used to test products for compliance to the indicated standards are calibrated regularly in accordance with ISO 17025 requirements.



Testing Certificate # 0955-01

I attest that the necessary measurements were made, under my supervision, at:

Timco Engineering Inc.  
849 NW State Road 45  
Newberry, Fl 32669



## Authorized Signatory Name:

Mario de Aranzeta C.E.T.  
Compliance Engineer/ Lab. Supervisor

**Date: February/8/2011**

Applicant: SUMMATION RESEARCH INC.  
FCC ID: OQW-STR1820  
Report: S\SUMMATION RESEARCH\108UT11\108UT11TestReport.doc

**GENERAL INFORMATION**

**DUT Specification**

<b>DUT Description</b>	LAND MOBILE RADIO FOR DATA COMMUNICATIONS
<b>FCC ID</b>	OQW-STR1820
<b>Model Number</b>	STR-1820
<b>Type of Emission</b>	11K2F3D, 16K0F3D, 16K0F2D, 11K2F2D
<b>Modulation</b>	FM
<b>DUT Power Source</b>	<input type="checkbox"/> 110-120Vac/50- 60Hz
	<input checked="" type="checkbox"/> DC Power 12V
	<input type="checkbox"/> Battery Operated Exclusively
<b>Test Item</b>	<input type="checkbox"/> Prototype
	<input checked="" type="checkbox"/> Pre-Production
	<input type="checkbox"/> Production
<b>Type of Equipment</b>	<input checked="" type="checkbox"/> Fixed
	<input type="checkbox"/> Mobile
	<input type="checkbox"/> Portable
<b>Test Conditions</b>	Temperature: 26°C Relative humidity: 50%
<b>Modification to the DUT</b>	None
<b>Test Exercise</b>	The DUT was placed in continuous transmit mode.
<b>Applicable Standards</b>	ANSI/TIA 603-C:2004, FCC CFR 47 Part 90
<b>Test Facility</b>	Timco Engineering Inc. at 849 NW State Road 45 Newberry, FL 32669 USA.

## EQUIPMENT LIST

Device	Manufacturer	Model	Serial Number	Cal/Char Date	Due Date
3-Meter Semi-Anechoic Chamber	Panashield	N/A	N/A	Listed 3/10/10	3/10/12
AC Voltmeter	HP	400FL	2213A14499	CAL 3/23/09	3/23/11
Antenna: Dipole Kit	Electro-Metrics	TDA-30/1-4	153	CHAR 6/10/09	6/10/11
Frequency Counter	HP	5385A	3242A07460	CAL 5/26/09	5/26/11
Hygro-Thermometer	Extech	445703	0602	CAL 1/30/09	1/30/11
Modulation Analyzer	HP	8901A	3435A06868	CAL 5/26/09	5/26/11
Digital Multimeter	Fluke	FLUKE-77-3	79510405	CAL 5/18/09	5/18/11
Analyzer Tan Tower Preamplifier	HP	8449B-H02	3008A00372	CAL 11/21/09	11/21/11
Analyzer Tan Tower Quasi-Peak Adapter	HP	85650A	3303A01690	CAL 11/22/09	11/22/11
Analyzer Tan Tower RF Preselector	HP	85685A	3221A01400	CAL 11/21/09	11/21/11
Analyzer Tan Tower Spectrum Analyzer	HP	8566B Opt 462	3138A07786 3144A20661	CAL 11/24/09	11/24/11
Temperature Chamber	Tenney Engineering	TTRC	11717-7	CHAR 4/25/10	4/25/12

## TEST PROCEDURE

**Power Line Conducted Interference:** The procedure used was ANSI/TIA 603-C: 2004, using a 50uH LISN. Both lines were observed with the DUT transmitting. The bandwidth of the spectrum analyzer was 10 kHz with an appropriate sweep speed.

**Bandwidth 20 dB:** The measurements were made with the spectrum analyzer's resolution bandwidth (RBW) = 1 MHz and the video bandwidth (VBW) = 3 MHz and the span set as shown on plot.

**Power Output:** The RF power output was measured at the antenna feed point using a peak power meter.

**Antenna Conducted Emissions:** The RBW = 100 kHz, VBW = 300 kHz and the span set to 10.0 MHz and the spectrum was scanned from 30 MHz to the 10<sup>th</sup> harmonic of the fundamental. Above 1 GHz the resolution bandwidth was 1 MHz and the VBW = 3 MHz and the span to 50 MHz.

**Radiation Interference:** The test procedure used was ANSI/TIA 603-C: 2004, using an Agilent spectrum receiver with pre-selector. The bandwidth (RBW) of the spectrum ANSI/TIA 603-C: 2004, receiver was 100 kHz up to 1 GHz and 1 MHz above 1 GHz with an appropriate sweep speed. The VBW above 1 GHz was 3 MHz. The analyzer was calibrated in dB above a microvolt at the output of the antenna.

## **OTHER MODULATION CHARACTERISTICS**

**Part 2.1033(c)**

**Part 2.1033(c) (4)** Type of Emission: 11K2F1D

**Part 90.209**

**Part 90.207**  $B_n = 2M + 2DK$

$$M = B/2 = 9600/2 = 4800$$

$$D = 800$$

$$K=1$$

$$B_n = 2(4800) + 2(800) = 11.2k$$

## **OCCUPIED BANDWIDTH**

### **Part 2.1049(c) Emission Bandwidth**

### **Part 90.210(b) 25kHz Channel Spacing**

Data in the plots show that on any frequency removed from the assigned frequency by more than 50%, but not more than 100%: At least 25dB. On any frequency removed from the assigned frequency by more than 100%, but not more than 250%: At least 35 dB. On any frequency removed from the assigned frequency by more than 250%, of the authorized bandwidth: At least  $43 + 10\log(P)$ dB.

### **Part 90.210(c) 12.5kHz Channel Spacing Not Equipped with a Low Pass Filter**

For transmitters that are not equipped with an audio low pass filter pursuant to S90.211 (b), the power of any emission must be attenuated below the un-modulated carrier output power as follows; (1) On any frequency removed from the center of the authorized bandwidth by a displacement frequency ( $f_d$  in kHz) of more than 5 kHz but not more than 10 kHz: At least  $83 \log(f_d/5)$  dB; (2) ON any frequency removed from the center of the authorized bandwidth by a displacement frequency ( $f_d$  in kHz) of more than 10 kHz, but not more than 250% of the authorized bandwidth: At least  $29 \log(f_d^2/11)$ dB or 50 dB, whichever is the lesser attenuation; (3) On any frequency removed from the center of the authorized bandwidth by more than 250% of the authorized bandwidth: At least  $43+10 \log(P_o)$ dB.

### **Part 90.210(d) Emission Mask D - 12.5 kHz channel BW equipment.**

For transmitters designed to operate with a 12.5 kHz channel bandwidth, any emission must be attenuated below the power (P) of the highest emission contained within the authorized bandwidth as follows:

- (1) On any frequency from the center of the authorized bandwidth  $f_0$  to 5.625 kHz removed from  $f_0$ : Zero dB.
- (2) On any frequency from the center of the authorized bandwidth by a displacement frequency ( $f_d$  in kHz) of more than 5.625 kHz but no more than 12.5 kHz: At least  $7.27(f_d - 2.88 \text{ kHz})$  dB.
- (3) On any frequency removed from the center of the authorized bandwidth by a displacement frequency ( $f_d$  in kHz) of more than 12.5 kHz: At least  $50 + 10\log(P)$  dB or 70 dB, whichever is the lesser attenuation.

### **Part 90.210(e) Emission Mask E - 6.25 kHz channel BW equipment.**

For transmitters designed to operate with a 6.25 kHz bandwidth, any emission must be attenuated below the power (P) of the highest emission contained within the authorized bandwidth as follows:

- (1) On any frequency from the center of the authorized bandwidth  $f_0$  to 3.0 kHz removed from  $f_0$ : Zero dB.
- (2) On any frequency from the center of the authorized bandwidth by a displacement frequency ( $f_d$  in kHz) of more than 3.0 kHz but no more than 4.6 kHz: At least  $30 + 16.67(f_d - 3.0 \text{ kHz})$  or  $55 + 10 \text{ Log}(P)$  or 65, whichever us the lesser attenuation.
- (3) On any frequency removed from the center of the authorized bandwidth by more than 4.6kHz: At least  $55 + 10\log(P)$  dB or 65 dB, whichever is the lesser attenuation.



**Method of Measurement: ANSI/TIA 603-C: 2004**

**Test Setup Diagram:**

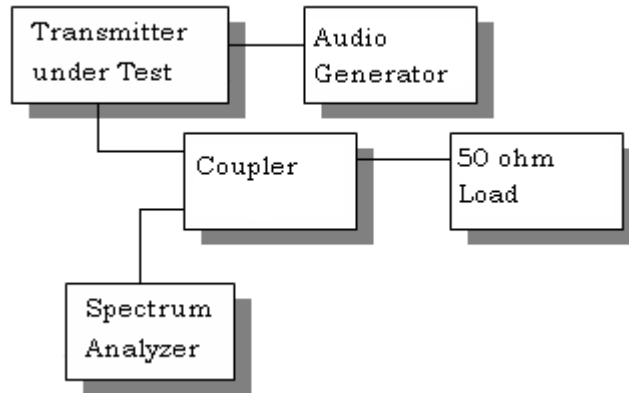

**Test Data:** See the plots below

## OCCUPIED BANDWIDTH PLOTS

Part 90.210(d) Emission Mask D - 12.5 kHz channel

**NOTES:**

**FCC 90.210 Mask D**

