

OWNER'S MANUAL

Keep for future reference

© Copyright 2004 PLAY (HK) LTD



www.playhk.com



COVERT OPERATIONS

FOR AGES
8 AND UP

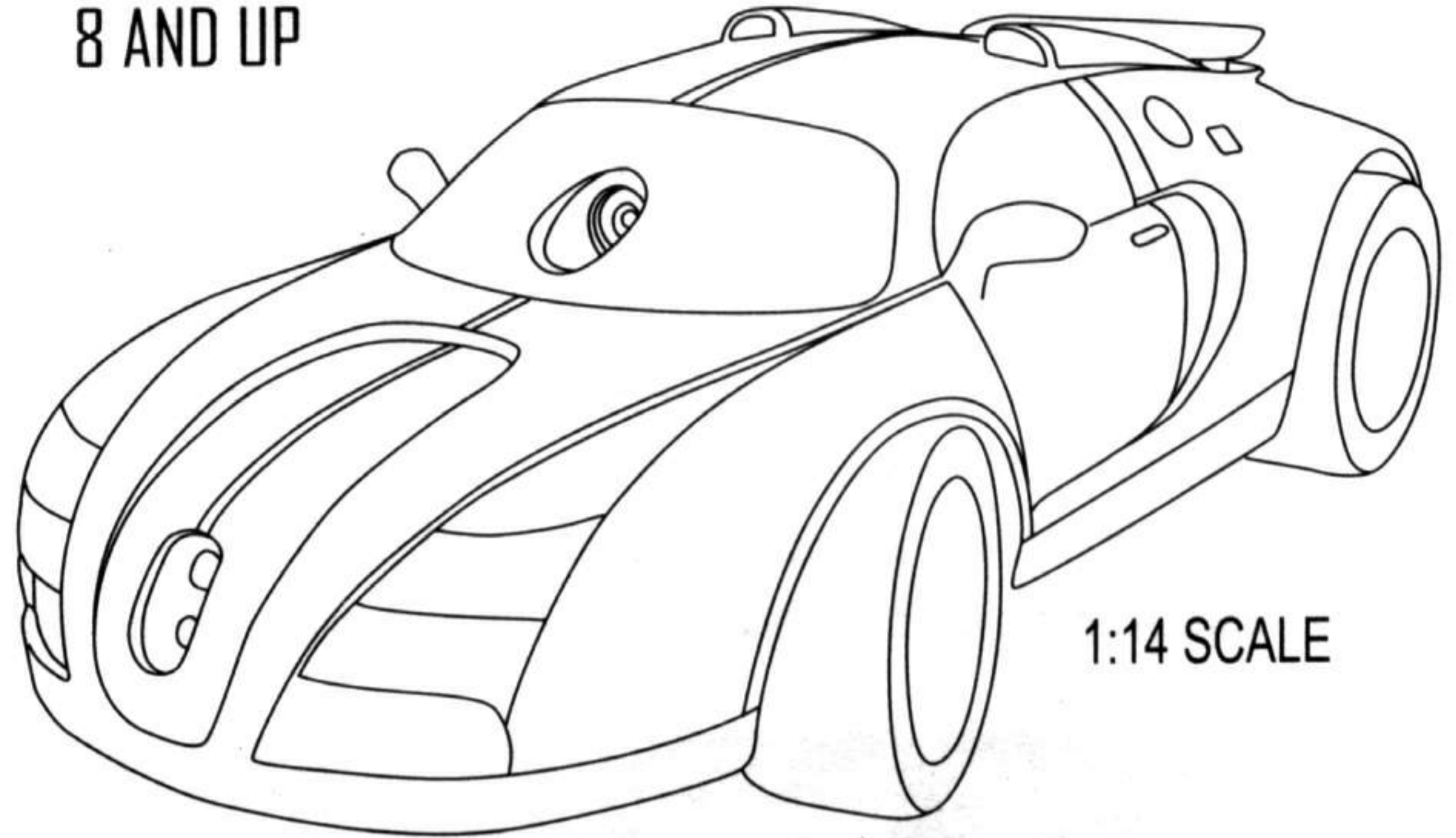
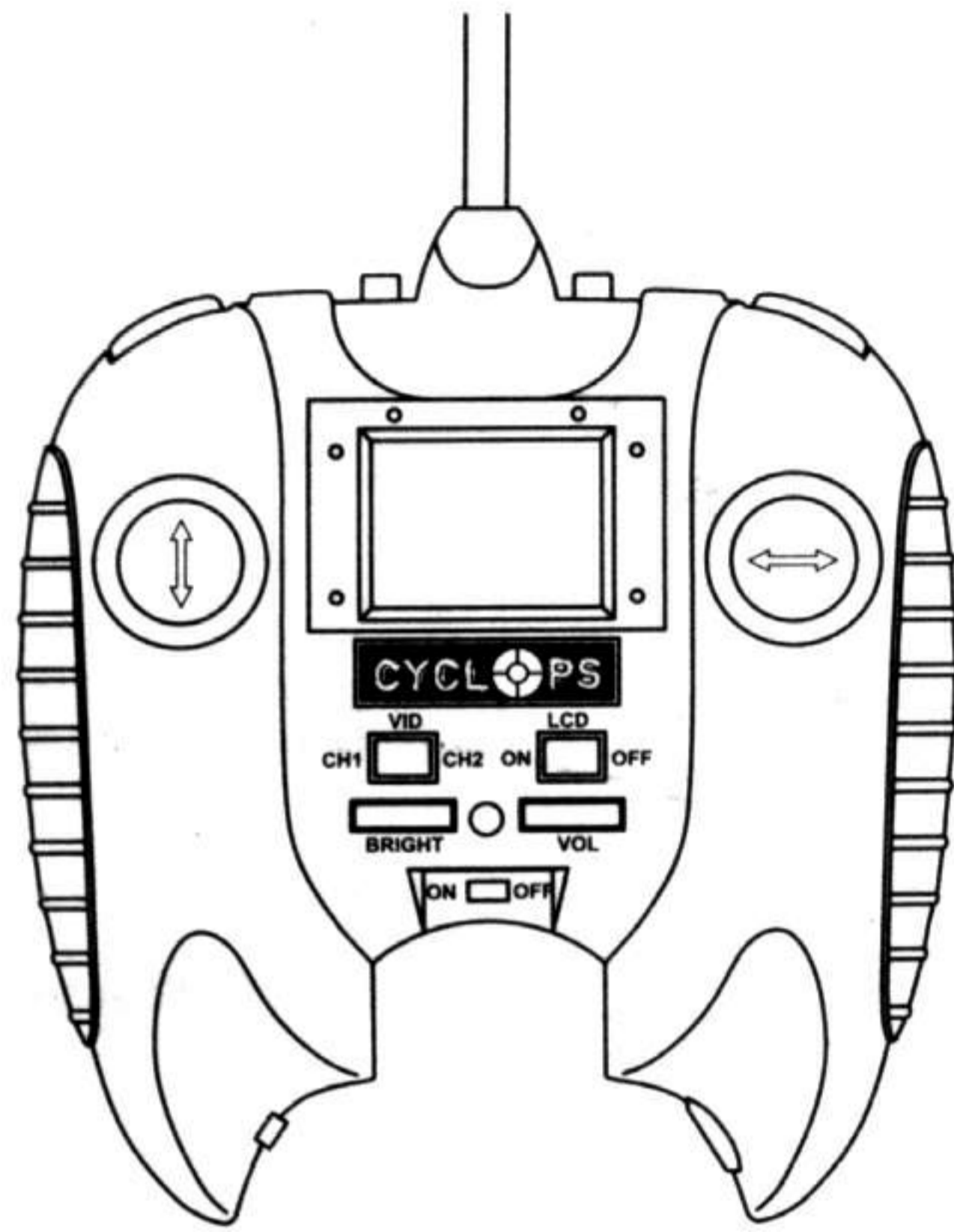

1:14 SCALE

FEATURES

High resolution wireless C-MOS video camera (2.4 GHz)

1.8 inch TFT color LCD display (30 frames per sec.)

Miniature wireless microphone

Infrared laser tag

RCA video and audio out

Ultra-bright headlights

High/low speed selector

Dual channels for two players

DC power input (adapter optional)

Safety wrist strap

SR21™
(SPECIAL RECON)

PRODUCT MUST BE PERIODICALLY EXAMINED FOR CONDITIONS THAT MAY RESULT IN THE RISK OF FIRE, ELECTRIC SHOCK, OR INJURY TO PERSONS. IN THE EVENT OF SUCH CONDITIONS, THE PRODUCT SHOULD NOT BE USED UNTIL PROPERLY REPAIRED.

SR21 SPECIAL RECON™

1. SET UP

FCC CAUTION

The changes or modifications not expressly approved by the party responsible for compliance could void the user's authority to operate the equipment.

To comply with the FCC RF exposure compliance requirements, this device and its antenna must not be co-located or operating to conjunction with any other antenna or transmitter.

INSTALLING THE BATTERIES

Notes: For best performance use rechargeable AA batteries.

Batteries should only be changed by an adult.

CONTROLLER:

1. Remove the locking screws on each of the battery doors.
2. Open the battery compartments by sliding the battery doors outwards.
3. Insert 4 AA **rechargeable** or **alkaline** batteries into each compartment making sure that the + and - poles of the batteries are positioned correctly as indicated.
4. Replace battery doors and locking screws.

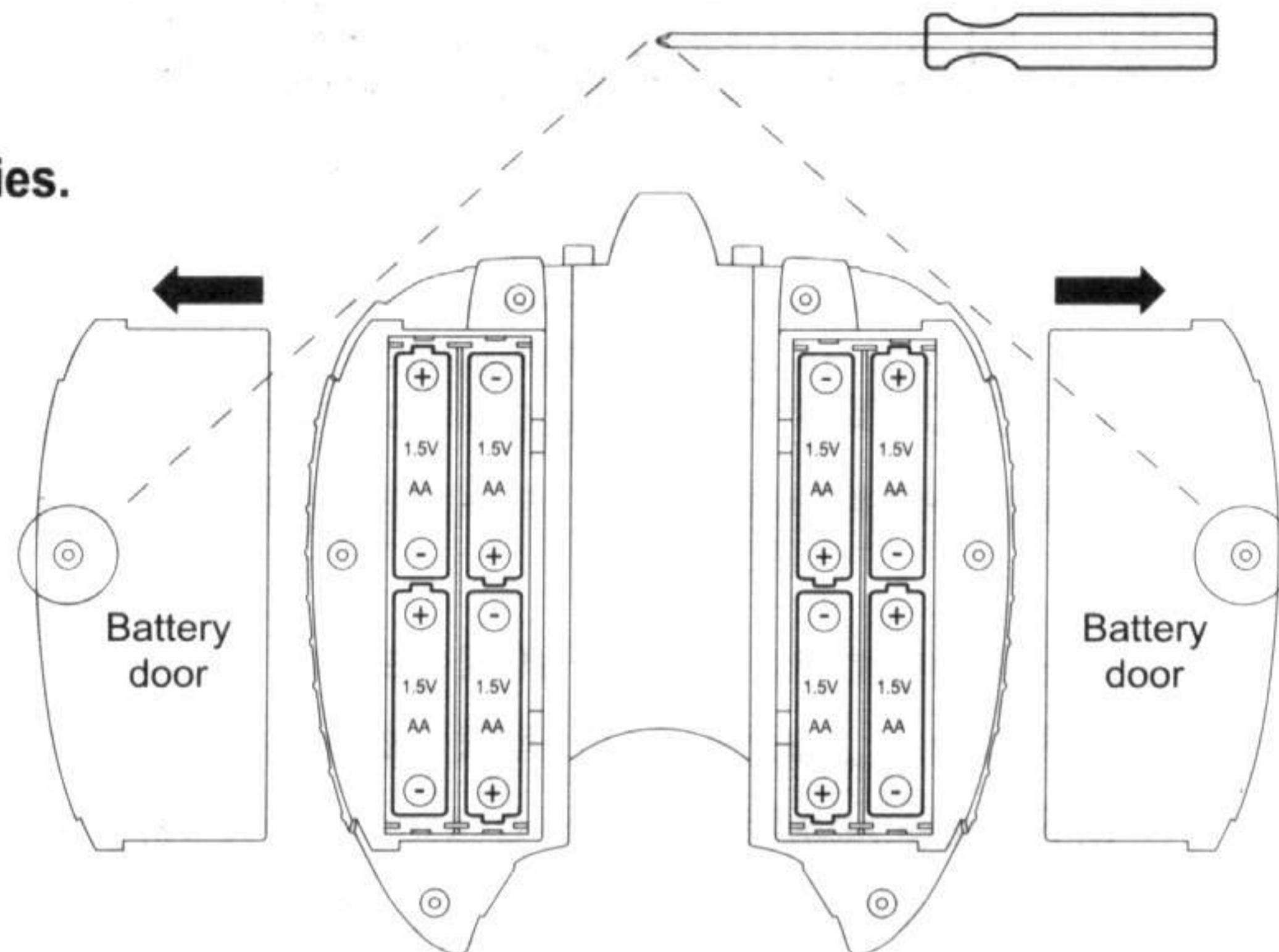

CAR:

1. Turn the car over and remove the battery compartment locking screw.
2. Open the battery compartment by pushing down on the lid and sliding it back. Pull the loose end of the power wires out of the compartment and connect them to the loose end of the battery pack or optional AA battery tray.

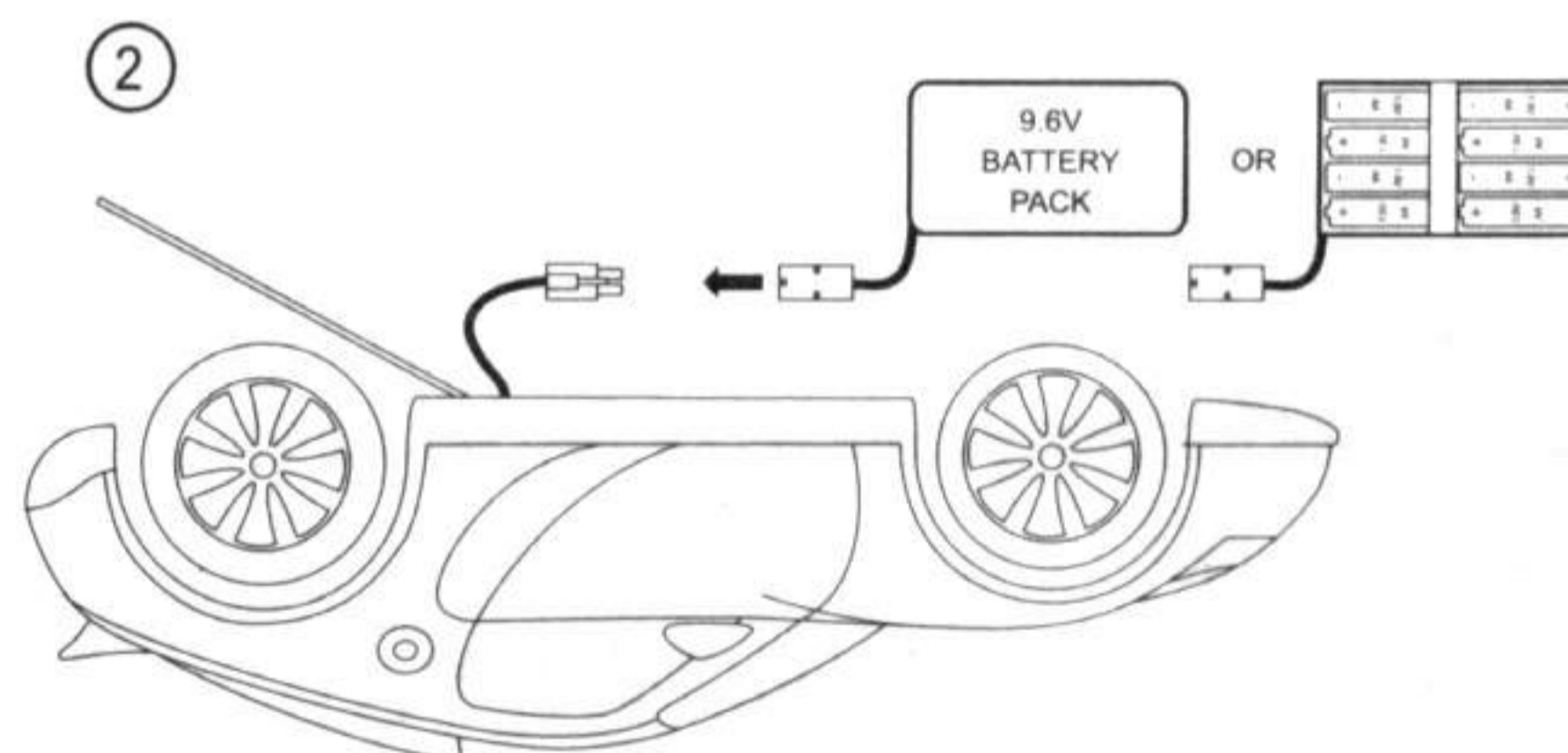
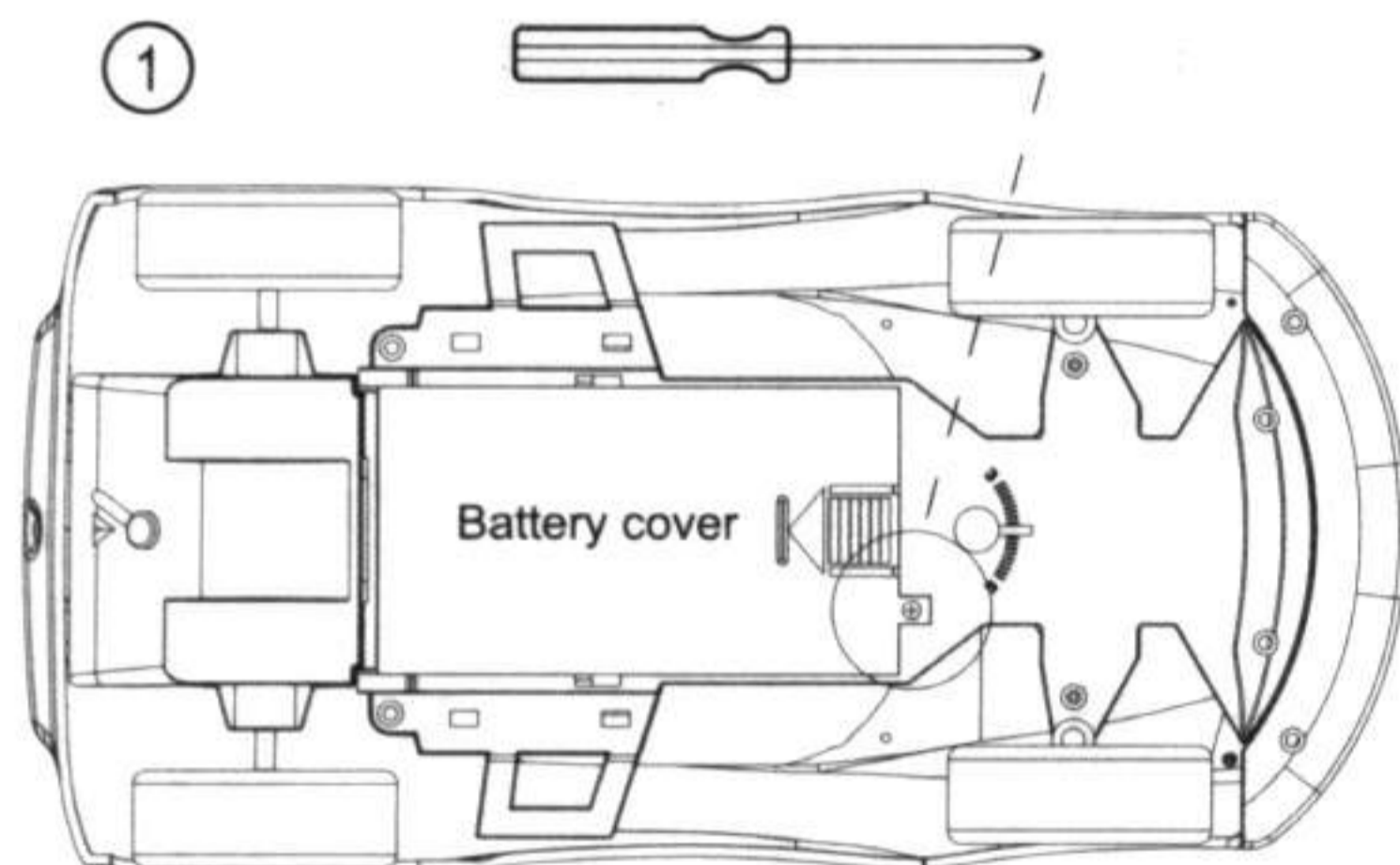

3. Insert the battery pack into the battery compartment, close the lid, and replace the locking screw.

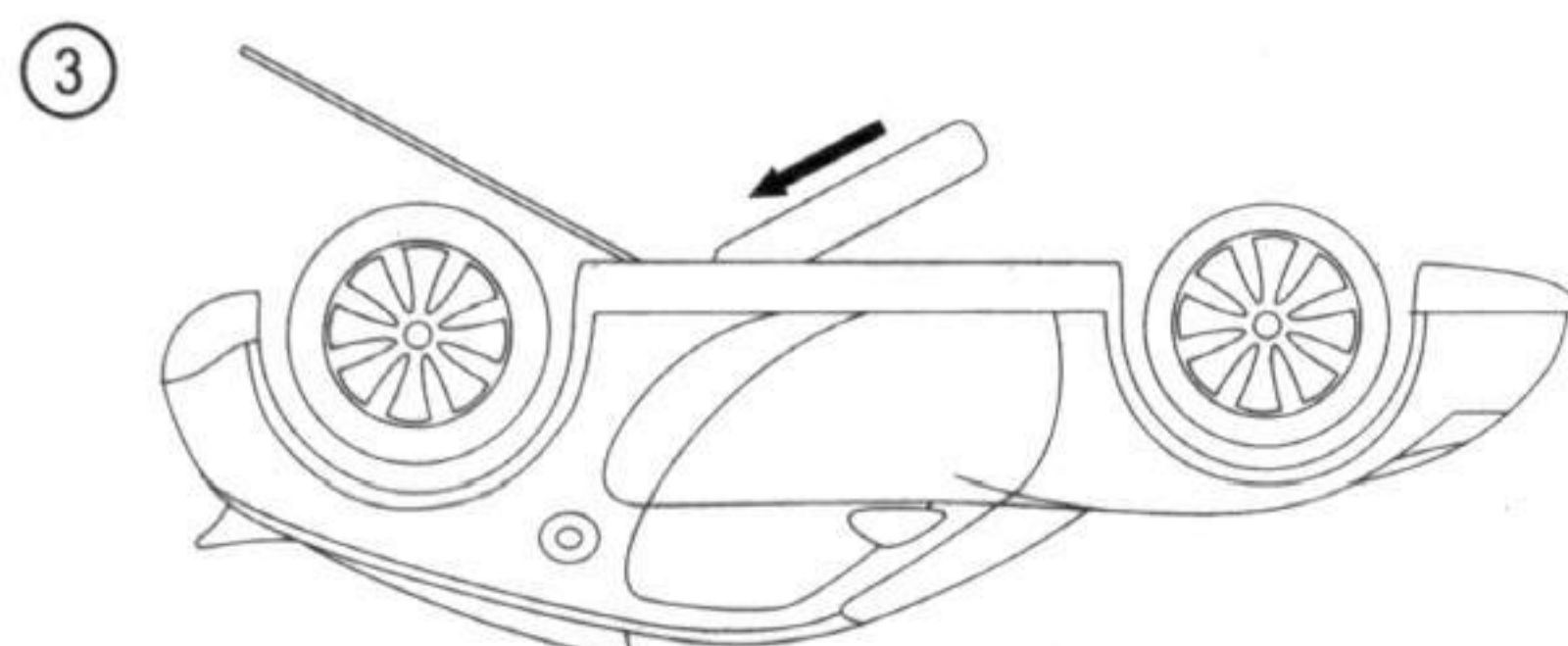

2. OPERATION

SUPER ADVANCED CONTROL SYSTEM (SACS)

The CYCLOPS™ SR1™ has the most advanced control system of any RC car in the world. Below are the many special features that make this vehicle so unique.

1. RCA video out to TV or VCR (yellow)
2. RCA audio out to TV or VCR (white)
3. Remote headlight switch & laser arming trigger
4. Laser firing trigger
5. 1.8 inch, 30 frames-per-second color TFT LCD display
6. Fwd/Rev steering thumb controls
7. L/R steering thumb controls
8. Video channel switch (for two players)
9. LCD display on/off switch (for power saving)
10. Volume control
11. Video brightness adjustment
12. LED power indicator light
13. Master power on/off switch
14. Radio control frequency switch (for two players)
15. Headphone jack (
16. DC power jack (Input: 12V DC, 1200mA)

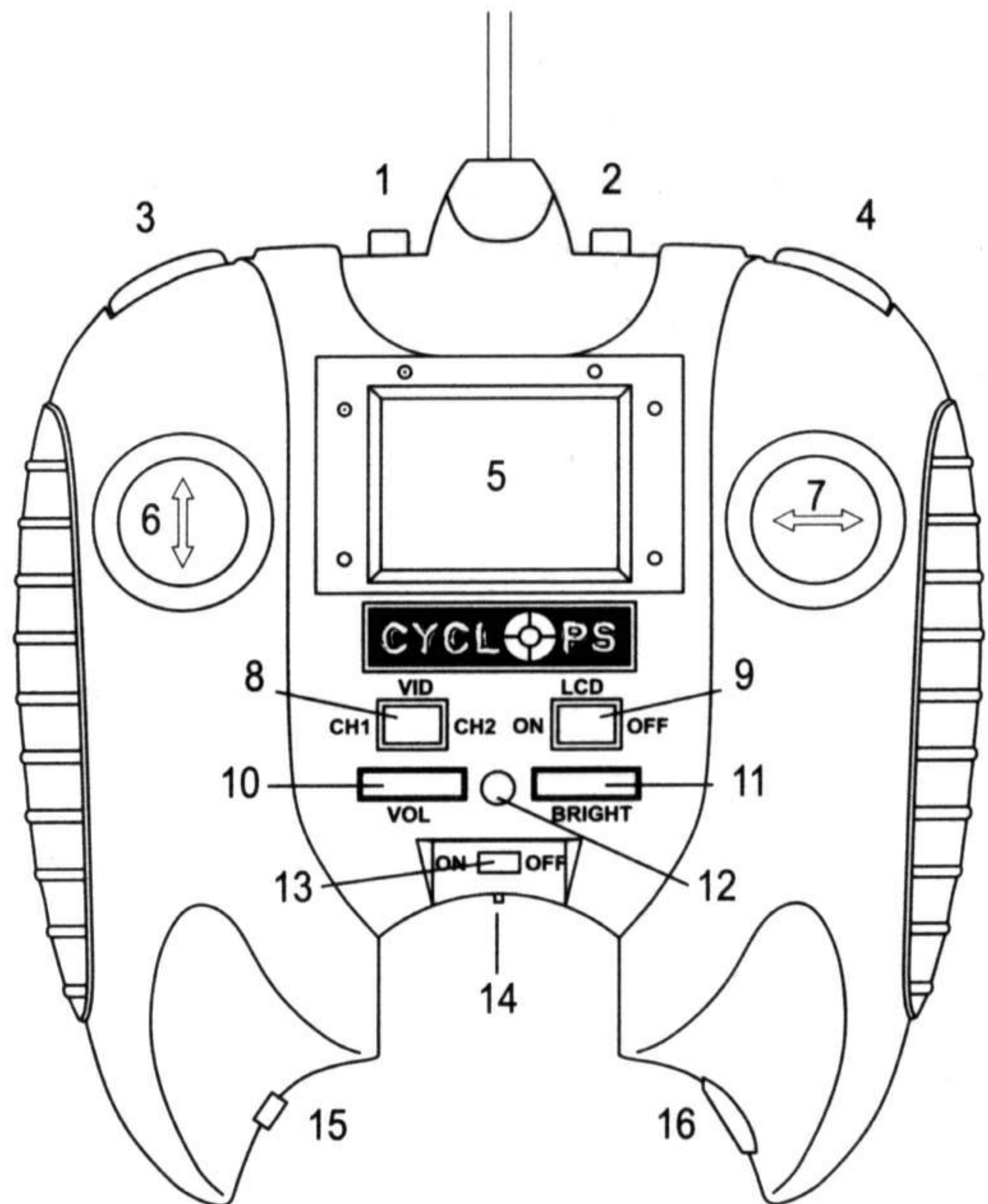

IMPORTANT NOTICES:

1. Like all radio controlled devices, this toy is susceptible to interference caused by radio frequencies emitted by other devices and by steel reinforced concrete structures. If performance is poor, first make sure the batteries in both the car and controller are freshly charged. If problems persist, try moving to a new location such as a larger space or outdoors.
2. The infrared lasers work best indoors. Normal distance is approximately 6 metres between cars. If operating outdoors, this distance will be affected by sunlight. In direct sunlight the distance may be reduced to as little as one metre.

CYCLOPS™ SR1™ SPY CAR

1. High resolution C-MOS video camera
2. Side infrared sensors
3. Wireless microphone
4. Infrared laser canon
5. Ultra-bright LED headlights
6. Front infrared sensor
7. Steering trim adjustment
8. Power on/off switch
9. Video channel switch (for two players)
10. RF channel switch (for two players)
11. High/Low speed switch
12. Rear infrared sensor

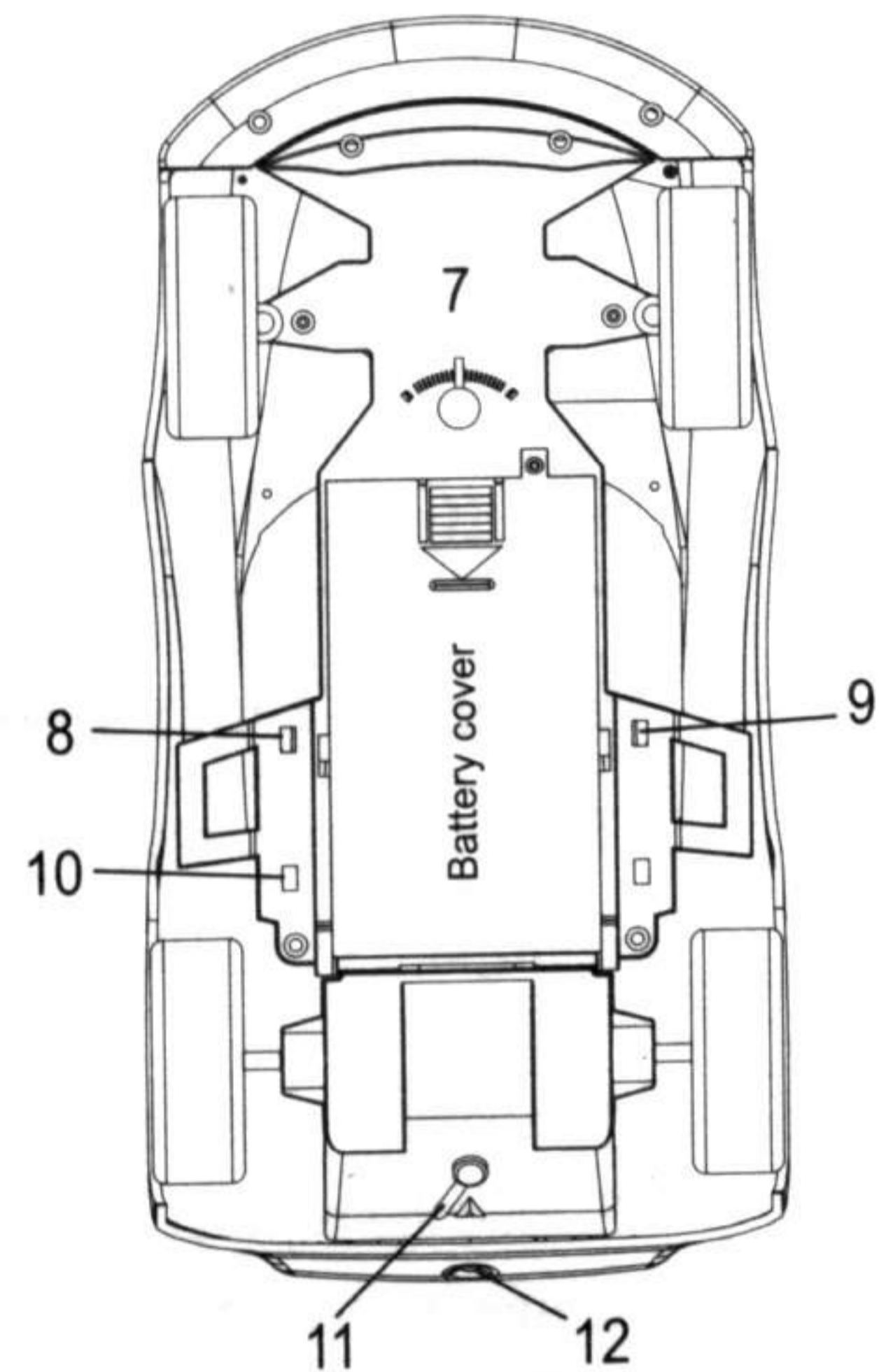
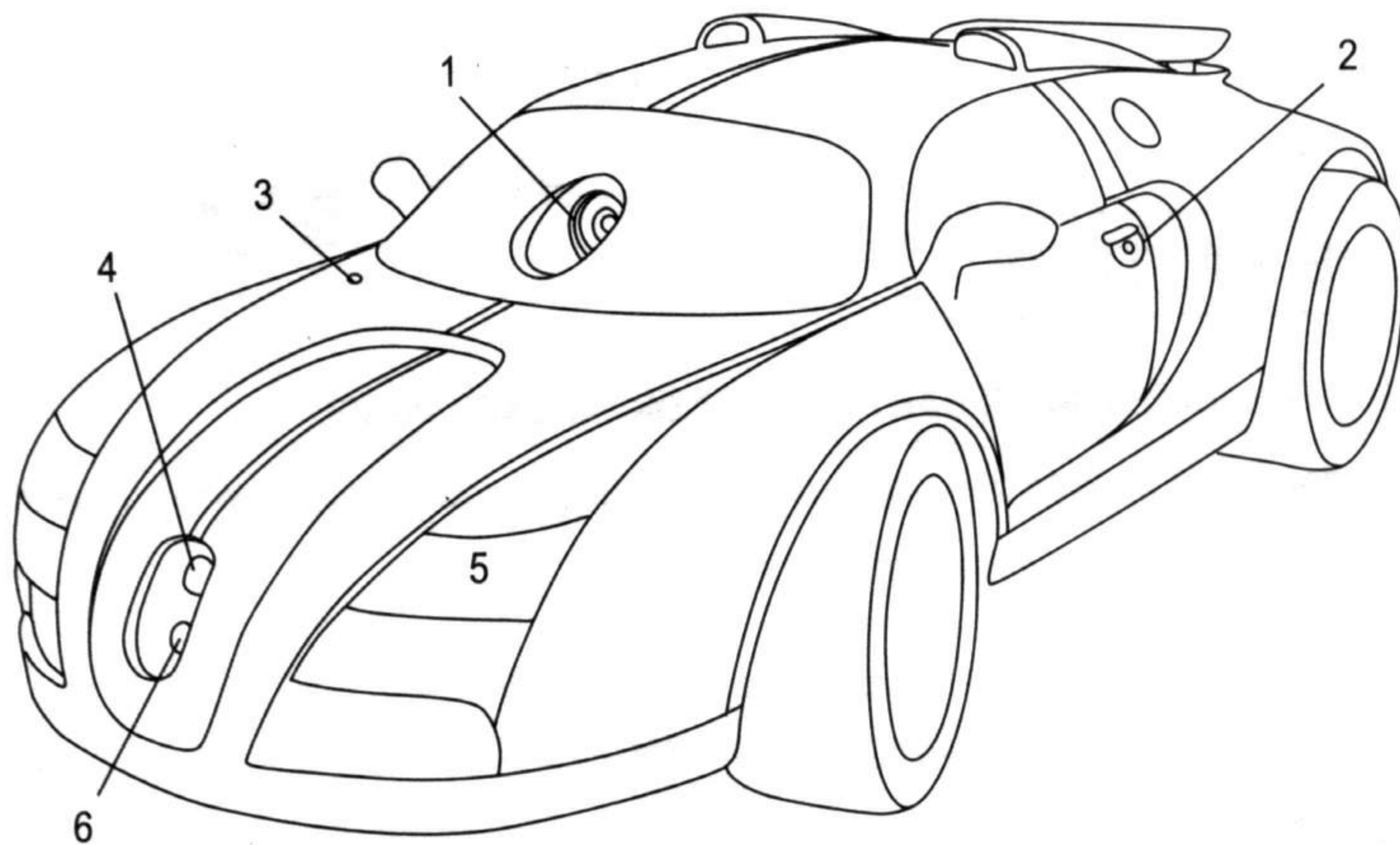

LASER TAG OPERATION AND PLAY

The CYCLOPS™ SR1™ is equipped with high-tech infrared lasers and sensors for playing laser tag with other CYCLOPS™ SR1™ cars (up to 2 players at once).

OPERATING THE LASER TAG SYSEM

1. Make sure both the SR1™ and the controller are switched on. (Indicated by red LED lights.)
2. Press the "Light" trigger on the controller to arm the laser system. The SR1™'s headlights will come on.
3. Press the "Laser" trigger on the controller to fire the laser canon. The SR1™ will emit a laser firing sound.

LASER TAG RULES AND PLAY

Just like a real spy car, the CYCLOPS™ SR1™ is equipped with high tech laser offensive and defensive systems.

1. When the laser system is first armed, the SR1™'s headlights will be lit and all four LED tail lights will be on.
2. Each time any one of the infrared sensors positioned on the four sides of the SR1™ is hit with a laser burst from another SR1™, all four of the LED tail lights will flash together and an audible alarm will sound for several seconds.
3. Afterward, one of the tail lights will go out, indicating a hit. This will be repeated each time a hit is received.
4. After four hits, the tail lights will flash and the alarm will sound, and then the car will be disabled for 10 seconds, during which time, the car will not respond to the controller.
5. To reset the lasers to start a new game, slide the ON/OFF switch on the bottom of the SR1™ to the off position and on again.

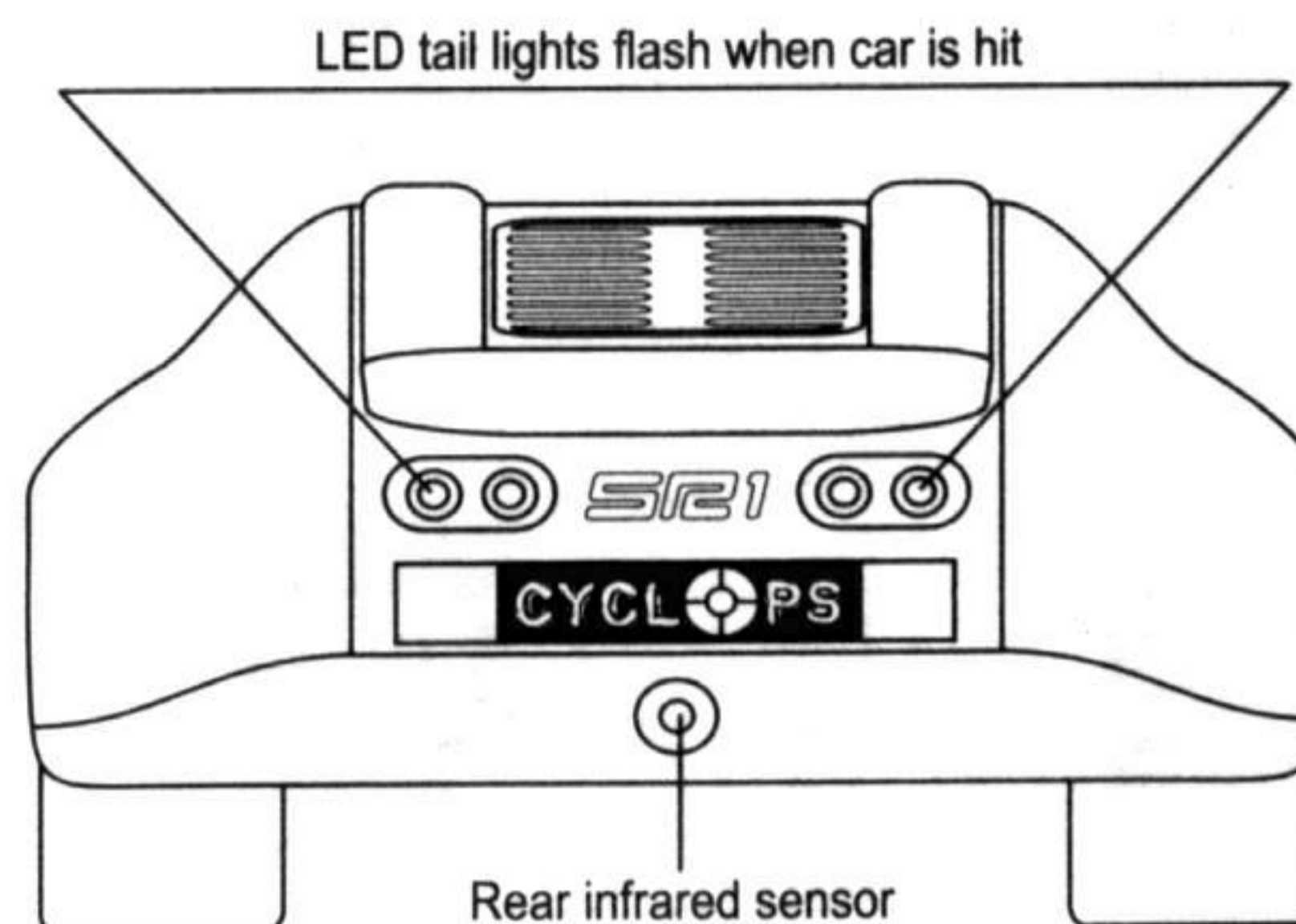

3. SAFETY & TROUBLESHOOTING

SAFE OPERATION *This toy requires regular cleaning and inspection for safe operation and optimal performance.

1. Use only rechargeable nickel cadmium or nickel metal hydride batteries of the same size and type supplied (or AA **alkaline** batteries and the optional battery tray).
2. Never let the battery or charger get wet. Do not take the battery pack or charger apart.
3. Never attempt to recharge non-rechargeable batteries. Recharging batteries should only be done under adult supervision.
4. Remove batteries from the toy before recharging. Do not over charge the batteries.
5. Remove empty batteries from the car and controller. And remove batteries if the toy will not be used for more than 30 days.
6. When inserting batteries, be sure to observe polarity indicators.
7. Never use batteries from different manufacturers, and never mix old and new batteries.
8. Never short circuit the battery terminals. Check terminals frequently for corrosion. Check batteries often for leakage.
9. Never operate this toy in wet weather or damp conditions. And never leave it exposed to direct sunlight or high temperatures for more than 10 minutes.

TROUBLE SHOOTING

PROBLEM:	CAUSE / SOLUTION:
Car does not move in straight line.	Adjust the steering alignment lever on bottom of car.
Poor range or picture quality.	Batteries may be weak. Replace/recharge batteries.
Car performs poorly or erratically.	Possible radio interference from electrical power lines, other devices, concrete walls. Move to a different location.
LCD picture is too dark or too bright.	1. Adjust brightness control dial. 2. Room may be too dark. Move to brighter location or turn on more lights.
Infrared lasers do not work properly.	1. Make sure reset switch on bottom of car is in the on position. 2. Make sure laser system is armed by turning on the lights. 3. Move indoors, as sunlight may interfere with infrared signals.