



FCC RF Test Report

APPLICANT : Wistron NeWeb Corporation
EQUIPMENT : NFC MODULE
BRAND NAME : WNC
MODEL NAME : XRAV-1
FCC ID : NKR-XRAV1
STANDARD : FCC Part 15 Subpart C §15.225
CLASSIFICATION : (DXX) Low Power Communication Device Transmitter

The testing was completed on Sep. 11, 2016. We, SPORTON INTERNATIONAL INC., would like to declare that the tested sample has been evaluated in accordance with the test procedures and has been in compliance with the applicable technical standards.

The test results in this report apply exclusively to the tested model / sample. Without written approval of SPORTON INTERNATIONAL INC., the test report shall not be reproduced except in full.

Reviewed by: Joseph Lin / Supervisor

Approved by: Jones Tsai / Manager



SPORTON INTERNATIONAL INC.

No. 52, Hwa Ya 1st Rd., Hwa Ya Technology Park, Kwei-Shan District, Tao Yuan City, Taiwan, R.O.C.



Table of Contents

SUMMARY OF THE TEST RESULT4
1. GENERAL INFORMATION.....5
1.1 Applicant5
1.2 Manufacturer.....5
1.3 Product Details.....5
1.4 Modification of EUT.....5
1.5 Testing Location6
1.6 Applicable Standards6
1.7 Test Modes.....6
1.8 Test Configurations.....7
1.9 Table for Supporting Units7
2. CONDUCTED EMISSION TEST.....8
2.1 Measuring Instruments8
2.2 Test setup8
2.3 Test Result of Conducted Emission Test.....8
2.4 AC Power Line Conducted Emissions Measurement9
3. CONDUCTED TEST ITEMS10
3.1 Measuring Instruments10
3.2 Test Setup10
3.3 Test Result of Conducted Test Items.....10
3.4 20dB and 99% OBW Spectrum Bandwidth Measurement.....11
3.5 Frequency Stability Measurement11
4. RADIATED TEST ITEMS.....12
4.1 Measuring Instruments12
4.2 Test Setup12
4.3 Test Result of Radiated Test Items12
4.4 Field Strength of Fundamental Emissions and Mask Measurement13
4.5 Radiated Emissions Measurement14
5. LIST OF MEASURING EQUIPMENT16
APPENDIX A. SETUP PHOTOGRAPHS OF EUT
APPENDIX B. TEST RESULTS OF CONDUCTED EMISSION TEST
APPENDIX C. TEST RESULTS OF CONDUCTED TEST ITEMS
C.1. Test Result of 20dB Spectrum Bandwidth
C.2 Test Result of Frequency Stability
APPENDIX D. TEST RESULTS OF RADIATED TEST ITEMS
D.1 Test Result of Field Strength of Fundamental Emissions
D.2 Results of Radiated Emissions (9 kHz~30MHz)
D.3 Results of Radiated Emissions (30MHz~1GHz)



REVISION HISTORY

REPORT NO.	VERSION	DESCRIPTION	ISSUED DATE
FR662805	Rev. 01	Initial issue of report	Aug. 04, 2016
FR662805	Rev. 02	Adding test setup photos with a close view of EUT	Sep. 26, 2016



SUMMARY OF THE TEST RESULT

Applied Standard: 47 CFR FCC Part 15 Subpart C				
Part	FCC Rule	Description of Test	Result	Under Limit
3.1	15.207	AC Power Line Conducted Emissions	Complies	4.10 dB at 13.558MHz
3.2	15.225(a)(b)(c)	Field Strength of Fundamental Emissions	Complies	48.38 dB at 13.560 MHz
3.3	2.1049	20dB Spectrum Bandwidth	Complies	-
3.3	-	99% OBW Spectrum Bandwidth	Complies	-
3.4	15.225(d) 15.209	Radiated Emissions	Complies	3.83 dB at 230.340 MHz
3.5	15.225(e)	Frequency Stability	Complies	-
3.6	15.203	Antenna Requirements	Complies	-

Test Items	Uncertainty	Remark
AC Power Line Conducted Emissions	±2.70dB	Confidence levels of 95%
Radiated Emissions (30MHz~1000MHz)	±4.80dB	Confidence levels of 95%



1. GENERAL INFORMATION

1.1 Applicant

Wistron NeWeb Corporation

20 Park Avenue II, Hsinchu Science Park, Hsinchu 308,Taiwan,R.O.C.

1.2 Manufacturer

Wistron NeWeb Corporation

20 Park Avenue II, Hsinchu Science Park, Hsinchu 308,Taiwan,R.O.C.

1.3 Product Details

Items	Description
Tx/Rx Frequency Range	13.553 ~ 13.567MHz
Channel Number	1
20dBW	2.66 KHz
99%OBW	2.24 KHz
Antenna Type	Loop Antenna
Type of Modulation	ASK

Remark: The above EUT's information was declared by manufacturer. Please refer to the specifications or user's manual for more detailed description.

1.4 Modification of EUT

No modifications are made to the EUT during all test items.

1.5 Testing Location

Sporton Lab is accredited to ISO 17025 by Taiwan Accreditation Foundation (TAF code : 1190) and the FCC designation No. TW1022 under the FCC 2.948(e) by Mutual Recognition Agreement (MRA) in FCC Test.

Test Site	SPORTON INTERNATIONAL INC.		
Test Site Location	No. 52, Hwa Ya 1 st Rd., Hwa Ya Technology Park, Kwei-Shan District, Tao Yuan City, Taiwan, R.O.C. TEL: +886-3-3273456 / FAX: +886-3-3284978		
Test Site No.	Sporton Site No.		
	TH03-HY	CO05-HY	03CH07-HY
Test Engineer	Kenny Chen	Kai-Chun Chu	James Chiu
Temperature	22~24°C	24~25°C	21~23°C
Relative Humidity	53~55%	51~52%	57~61%

Note: The test site complies with ANSI C63.4 2014 requirement.

1.6 Applicable Standards

According to the specifications of the manufacturer, the EUT must comply with the requirements of the following standards:

- ♦ FCC Part 15 Subpart C §15.225
- ♦ ANSI C63.10-2013

1.7 Test Modes

Investigation has been done on all the possible configurations for searching the worst cases. The following table is a list of the test modes shown in this test report.

Test Items	
AC Power Line Conducted Emissions	Field Strength of Fundamental Emissions
20dB Spectrum Bandwidth	Frequency Stability
Radiated Emissions 9kHz~30MHz	Radiated Emissions 30MHz~1GHz
Note:	
1. The EUT was programmed to be in continuously transmitting mode.	
2. The ancillary equipment, NFC card, is used to make the EUT (NFC) continuously transmit at 13.56MHz and is placed around 3 cm gap to the EUT.	

1.8 Test Configurations

<AC Conducted Emissions>

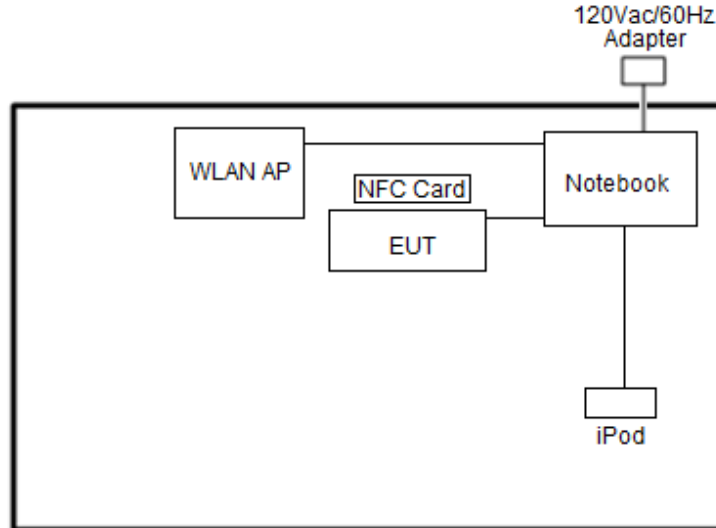

< For Fundamental Emissions and Mask and Radiated Emissions Measurement >

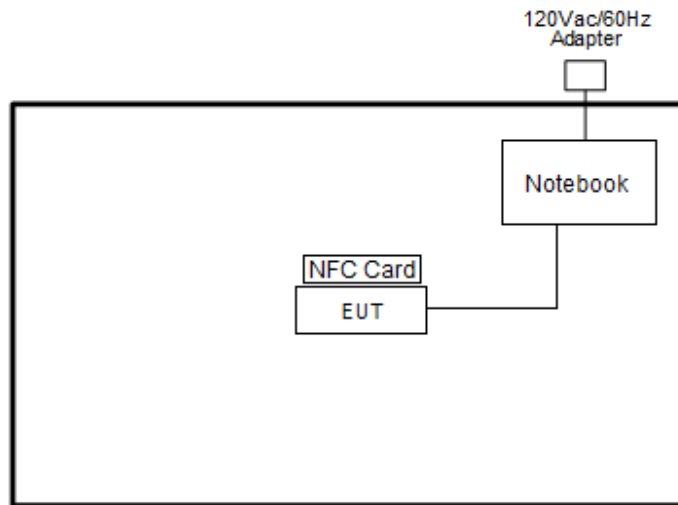

1.9 Table for Supporting Units

Support Unit	Manufacturer	Model	FCC ID
Notebook	DELL	Latitude E6320	FCC DoC/ Contains FCC ID: QDS-BRCM1054
Notebook	Lenovo	TP00034A	FCC DoC
WLAN AP	ASUS	RT-AC66U	MSQ-ETAC66U
iPod	Apple	A1285	FCC DoC
NFC Card	Metro Taipei	Easy Card	N/A

2. CONDUCTED EMISSION TEST

2.1 Measuring Instruments

See list of measuring instruments of this test report.

2.2 Test setup

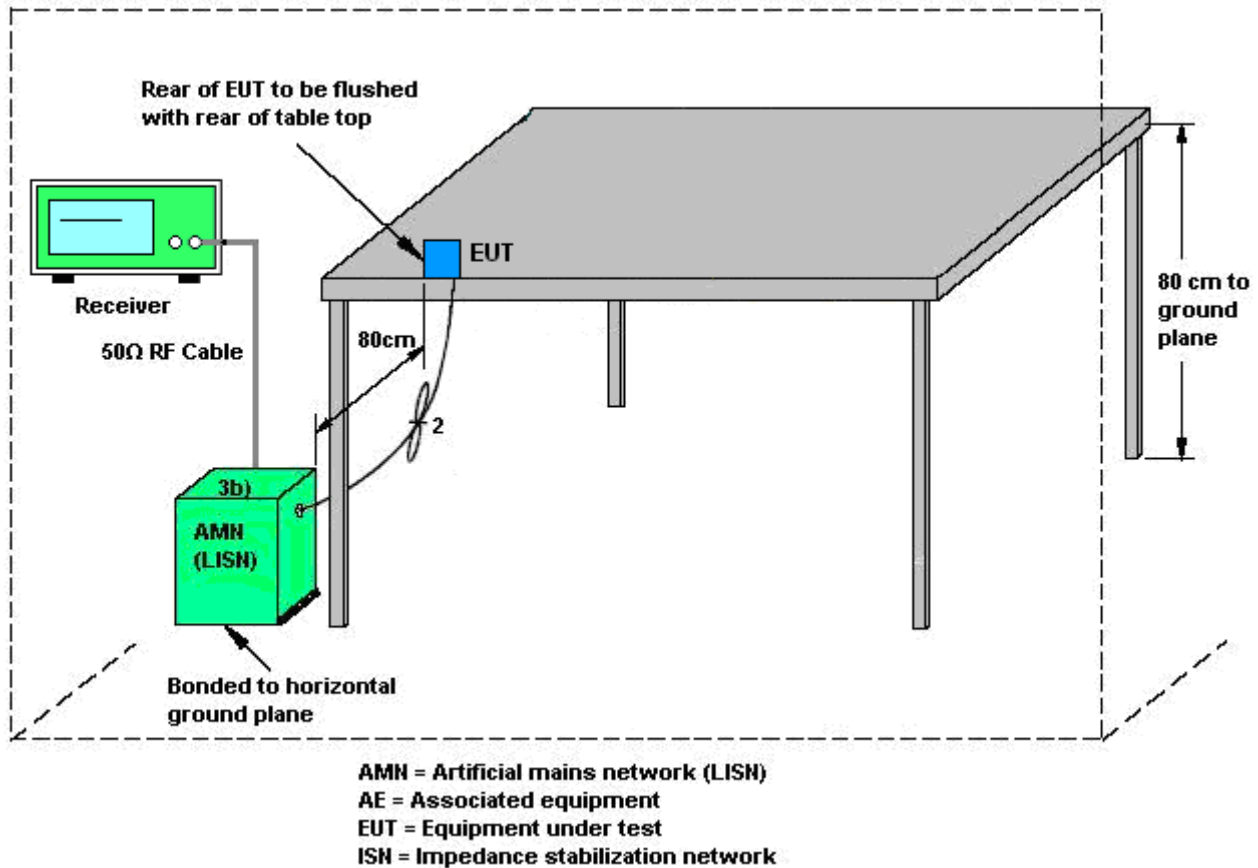

2.3 Test Result of Conducted Emission Test

Please refer to Appendix B.



2.4 AC Power Line Conducted Emissions Measurement

2.4.1 Limit

For equipment that is designed to be connected to the public utility (AC) power line, the radio frequency voltage that is conducted back onto the AC power line on any frequency or frequencies within the band 150 kHz to 30 MHz shall not exceed the limits in the following table.

Frequency of Emission (MHz)	Conducted Limit (dB μ V)	
	Quasi-Peak	Average
0.15-0.5	66 to 56*	56 to 46*
0.5-5	56	46
5-30	60	50

*Decreases with the logarithm of the frequency.

2.4.2 Test Procedures

1. The EUT was placed 0.4 meter from the conducting wall of the shielding room, and it was kept at least 80 centimeters from any other grounded conducting surface.
2. Connect EUT to the power mains through a line impedance stabilization network (LISN).
3. All the support units are connecting to the other LISN.
4. The LISN provides 50 ohm coupling impedance for the measuring instrument.
5. The FCC states that a 50 ohm, 50 microhenry LISN should be used.
6. Both sides of AC line were checked for maximum conducted interference.
7. The frequency range from 150 kHz to 30 MHz was searched.
8. Set the test-receiver system to Peak Detect Function and specified bandwidth (IF Bandwidth = 9kHz) with Maximum Hold Mode. Then measurement is also conducted by Average Detector and Quasi-Peak Detector Function respectively.

3. CONDUCTED TEST ITEMS

3.1 Measuring Instruments

See list of measuring instruments of this test report.

3.2 Test Setup

3.2.1 20dB and 99% OBW Spectrum Bandwidth

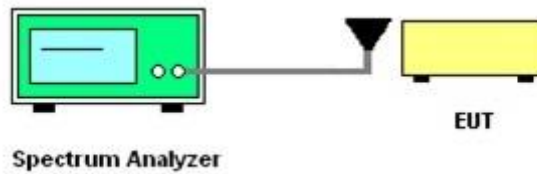

3.2.2 Frequency Stability

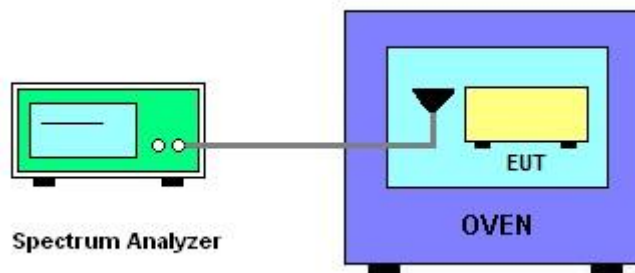

3.3 Test Result of Conducted Test Items

Please refer to Appendix C.



3.4 20dB and 99% OBW Spectrum Bandwidth Measurement

3.4.1 Limit

Intentional radiators must be designed to ensure that the 20dB and 99% emission bandwidth in the specific band 13.553~13.567MHz.

3.4.2 Test Procedures

1. The spectrum analyzer connected via a receive antenna placed near the EUT in peak Max hold mode.
2. The resolution bandwidth of 1 kHz and the video bandwidth of 3 kHz were used.

Measured the spectrum width with power higher than 20dB below carrier.

Measured the 99% OBW.

3.5 Frequency Stability Measurement

3.5.1 Limit

The frequency tolerance of the carrier signal shall be maintained within +/- 0.01% (100ppm) of the operating frequency over a temperature variation of -20 degrees to +50 degrees C at normal supply voltage, and for a variation in the primary supply voltage from 85% to 115% of the rated supply voltage at a temperature of 20 degrees C. For battery operated equipment, the equipment tests shall be performed using a new battery.

3.5.2 Test Procedures

1. The spectrum analyzer connected via a receive antenna placed near the EUT.
2. EUT have transmitted signal and fixed channelize.
3. Set the spectrum analyzer span to view the entire emissions bandwidth.
4. Set RBW = 1 kHz, VBW = 3 kHz with peak detector and maxhold settings.
5. The f_c is declaring of channel frequency. Then the frequency error formula is $(f_c-f)/f_c \times 10^6$ ppm and the limit is less than ± 100 ppm.
6. Extreme temperature rule is -20°C~50°C.

4. RADIATED TEST ITEMS

4.1 Measuring Instruments

See list of measuring instruments of this test report.

4.2 Test Setup

4.2.1 For radiated emissions below 30MHz

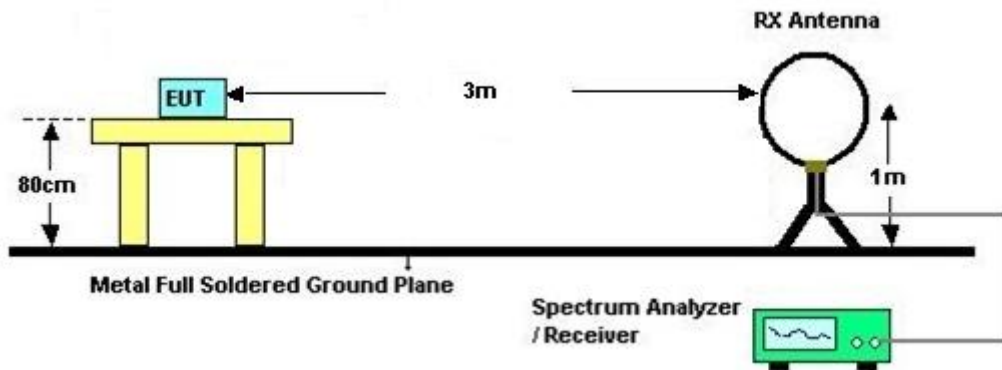

4.2.2 For radiated emissions above 30MHz

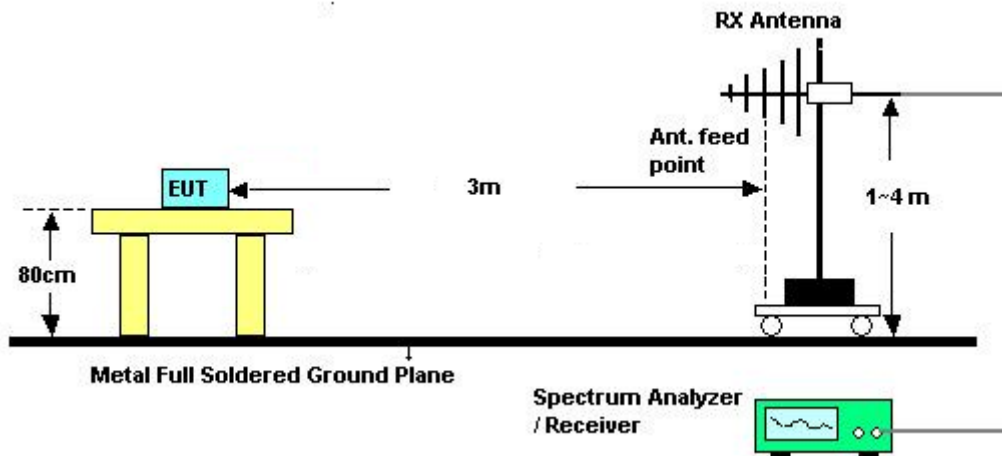

4.3 Test Result of Radiated Test Items

Please refer to Appendix D.



4.4 Field Strength of Fundamental Emissions and Mask Measurement

4.4.1 Limit

Rules and specifications	FCC CFR 47 Part 15 section 15.225			
Description	Compliance with the spectrum mask is tested with RBW set to 9kHz.			
Freq. of Emission (MHz)	Field Strength (µV/m) at 30m	Field Strength (dBµV/m) at 30m	Field Strength (dBµV/m) at 10m	Field Strength (dBµV/m) at 3m
1.705~13.110	30	29.5	48.58	69.5
13.110~13.410	106	40.5	59.58	80.5
13.410~13.553	334	50.5	69.58	90.5
13.553~13.567	15848	84.0	103.08	124.0
13.567~13.710	334	50.5	69.58	90.5
13.710~14.010	106	40.5	59.58	80.5
14.010~30.000	30	29.5	48.58	69.5

4.4.2 Test Procedures

1. Configure the EUT according to ANSI C63.10. The EUT was placed on the top of the turntable 0.8 meter above ground. The phase center of the loop receiving antenna mounted antenna tower was placed 3 meters far away from the turntable.
2. Power on the EUT and all the supporting units. The turntable was rotated by 360 degrees to determine the position of the highest radiation.
3. The height of the receiving antenna was fixed at one meter above ground to find the maximum emissions field strength.
4. For Fundamental emissions, use the receiver to measure QP reading.
5. When the radiated emissions limits are expressed in terms of the average value of the emissions, and pulsed operation is employed, the measurement field strength shall be determined by averaging over one complete pulse train, including blanking intervals, as long as the pulse train does not exceed 0.1 seconds. As an alternative (provided the transmitter operates for longer than 0.1 seconds) or in cases where the pulse train exceeds 0.1 seconds, the measured field strength shall be determined from the average absolute voltage during a 0.1 second interval during which the field strength is at its maximum value.
6. Compliance with the spectrum mask is tested with RBW set to 9kHz.

Note: Emission level (dBµV/m) = 20 log Emission level (µV/m).



4.5 Radiated Emissions Measurement

4.5.1 Limit

The field strength of any emissions which appear outside of 13.110 ~14.010MHz band shall not exceed the general radiated emissions limits.

Frequencies (MHz)	Field Strength (µV/m)	Measurement Distance (meters)
0.009~0.490	2400/F(kHz)	300
0.490~1.705	24000/F(kHz)	30
1.705~30.0	30	30
30~88	100	3
88~216	150	3
216~960	200	3
Above 960	500	3

4.5.2 Measuring Instrument Setting

The following table is the setting of receiver.

Receiver Parameter	Setting
Attenuation	Auto
Frequency Range: 9kHz~150kHz	RBW 200Hz for QP
Frequency Range: 150kHz~30MHz	RBW 9kHz for QP
Frequency Range: 30MHz~1000MHz	RBW 120kHz for Peak

Note: The emission limits shown in the above table are based on measurements employing a CISPR quasi-peak detector except for the frequency bands 9-90 kHz, 110-490 kHz. Radiated emission limits in these two bands are based on measurements employing an average detector.



4.5.3 Test Procedures

1. Configure the EUT according to ANSI C63.10. The EUT was placed on the top of the turntable 0.8 meter above ground. The phase center of the receiving antenna mounted on the top of a height-variable antenna tower was placed 3 meters far away from the turntable.
2. Power on the EUT and all the supporting units. The turntable was rotated by 360 degrees to determine the position of the highest radiation.
3. The height of the broadband receiving antenna was varied between one meter and four meters above ground to find the maximum emissions field strength of both horizontal and vertical polarization.
4. For each suspected emissions, the antenna tower was scan (from 1 M to 4 M) and then the turntable was rotated (from 0 degree to 360 degrees) to find the maximum reading.
5. Set the test-receiver system to Peak or CISPR quasi-peak Detect Function with specified bandwidth under Maximum Hold Mode.
6. When the radiated emissions limits are expressed in terms of the average value of the emissions, and pulsed operation is employed, the measurement field strength shall be determined by averaging over one complete pulse train, including blanking intervals, as long as the pulse train does not exceed 0.1 seconds. As an alternative (provided the transmitter operates for longer than 0.1 seconds) or in cases where the pulse train exceeds 0.1 seconds, the measured field strength shall be determined from the average absolute voltage during a 0.1 second interval during which the field strength is at its maximum value.
7. In case the emission is lower than 30MHz, loop antenna has to be used for measurement and the recorded data should be QP measured by receiver. Antenna Requirements

4.5.4 Limit

Except for special regulations, the Low-power Radio-frequency Devices must not be equipped with any jacket for installing an antenna with extension cable. An intentional radiator shall be designed to ensure that no antenna other than that furnished by the responsible party shall be used with the device. The use of a permanently attached antenna or of an antenna that uses a unique coupling to the intentional radiator shall be considered sufficient to comply with the provisions of this Section. The manufacturer may design the unit so that the user can replace a broken antenna, but the use of a standard antenna jack or electrical connector is prohibited.

4.5.5 Antenna Anti-Replacement Construction

An embedded-in antenna design is used.



5. LIST OF MEASURING EQUIPMENT

Instrument	Manufacturer	Model No.	Serial No.	Characteristics	Calibration Date	Test Date	Due Date	Remark
Spectrum Analyzer	Rohde & Schwarz	FSP30	101329	9kHz~30GHz	Jun. 27, 2016	Jul. 25, 2016	Jun. 26, 2017	Conducted (TH03-HY)
Temperature Chamber	ESPEC	SU-641	92013721	-30°C ~70°C	Nov. 20, 2015	Jul. 25, 2016	Nov. 19, 2016	Conducted (TH03-HY)
Programmable Power Supply	GW Instek	PSS-2005	EL883644	Voltage:0~20V; Current:0~5A	Nov. 26, 2015	Jul. 25, 2016	Nov. 25, 2016	Conducted (TH03-HY)
AC Power Source	ChainTek	APC-1000W	N/A	N/A	N/A	Jul. 06, 2016	N/A	Conduction (CO05-HY)
EMI Test Receiver	Rohde & Schwarz	ESCI 7	100724	9kHz~7GHz	Aug. 26, 2015	Jul. 06, 2016	Aug. 25, 2016	Conduction (CO05-HY)
LISN	Rohde & Schwarz	ENV216	100080	9kHz~30MHz	Dec. 02, 2015	Jul. 06, 2016	Dec. 01, 2016	Conduction (CO05-HY)
LISN	Rohde & Schwarz	ENV216	100081	9kHz~30MHz	Dec. 14, 2015	Jul. 06, 2016	Dec. 13, 2016	Conduction (CO05-HY)
Bilog Antenna	TESEQ	CBL 6111D	35419	30MHz to 1GHz	Jan. 13, 2016	Sep. 11, 2016	Jan. 12, 2017	Radiation (03CH07-HY)
EMI Test Receiver	Keysight	N9038A (MXE)	MY54130085	20Hz ~ 8.4GHz	Nov. 04, 2015	Sep. 11, 2016	Nov. 03, 2016	Radiation (03CH07-HY)
Loop Antenna	Rohde & Schwarz	HFH2-Z2	100315	9 kHz~30 MHz	Sep. 02, 2015	Sep. 11, 2016	Sep. 01, 2017	Radiation (03CH07-HY)
Preamplifier	MITEQ	AMF-7D-0010 1800-30-10P	1590075	1GHz ~ 18GHz	Apr. 15, 2016	Sep. 11, 2016	Apr. 14, 2017	Radiation (03CH07-HY)
Spectrum Analyzer	Agilent	N9010A	MY53470118	10Hz~44GHz	Feb. 27, 2016	Sep. 11, 2016	Feb. 26, 2017	Radiation (03CH07-HY)
Antenna Mast	Max-Full	MFA520BS	N/A	1m~4m	N/A	Sep. 11, 2016	N/A	Radiation (03CH07-HY)
Turn Table	ChainTek	Chaintek 3000	N/A	0~360 Degree	N/A	Sep. 11, 2016	N/A	Radiation (03CH07-HY)
Preamplifier	COM-POWER	PA-103A	161241	10MHz~1GHz	Mar. 18, 2016	Sep. 11, 2016	Mar. 17, 2017	Radiation (03CH07-HY)

Appendix B. Test Results of Conducted Emission Test

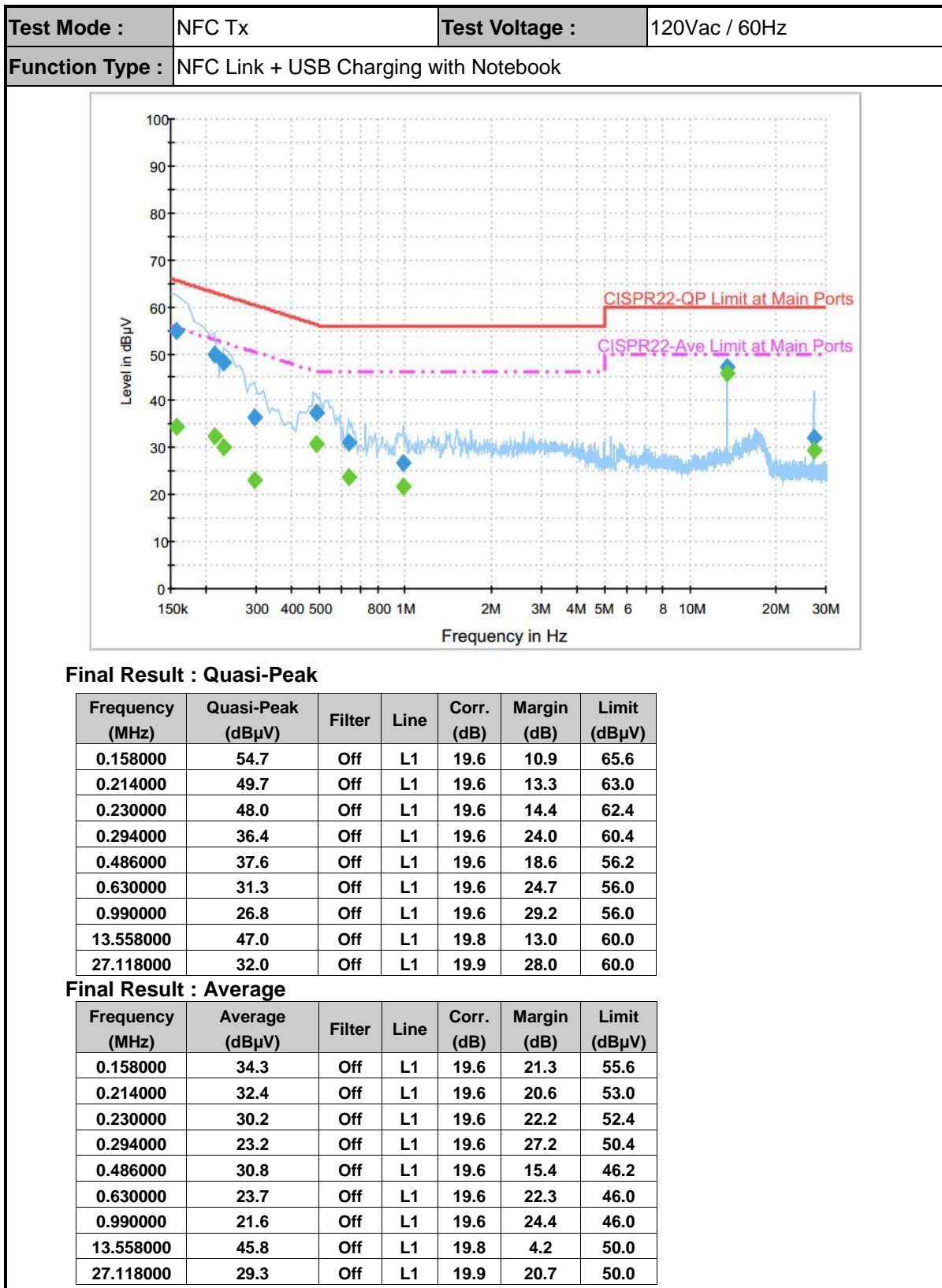



Test Mode :	NFC Tx	Test Voltage :	120Vac / 60Hz
Function Type :	NFC Link + USB Charging with Notebook		

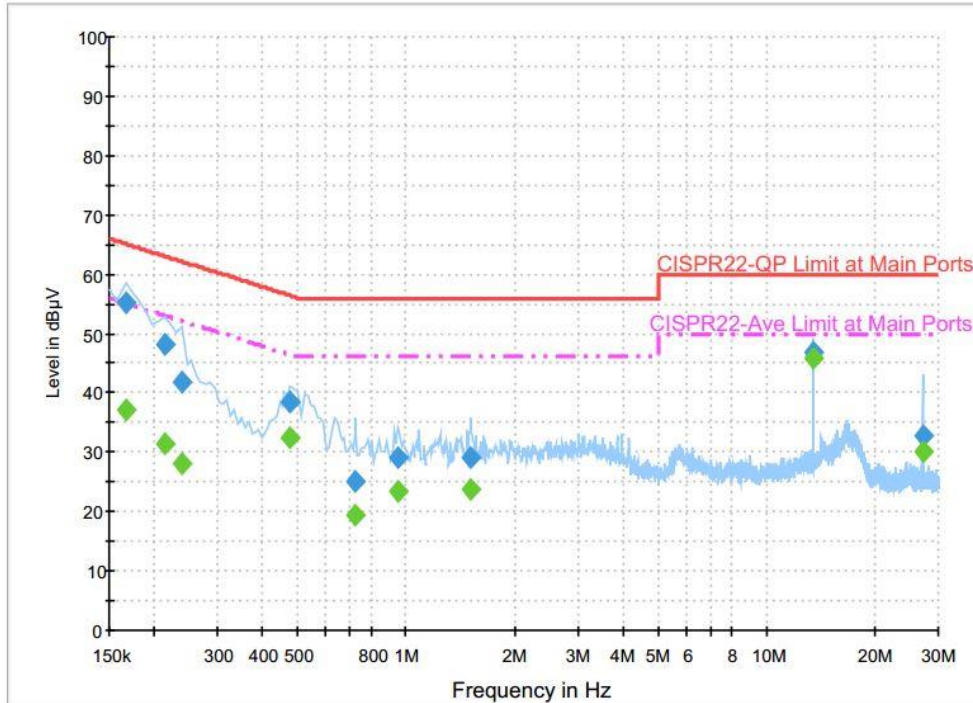

Final Result : Quasi-Peak

Frequency (MHz)	Quasi-Peak (dBµV)	Filter	Line	Corr. (dB)	Margin (dB)	Limit (dBµV)
0.166000	55.3	Off	N	19.6	9.9	65.2
0.214000	48.2	Off	N	19.6	14.8	63.0
0.238000	41.9	Off	N	19.6	20.3	62.2
0.478000	38.4	Off	N	19.6	18.0	56.4
0.726000	25.2	Off	N	19.6	30.8	56.0
0.950000	29.0	Off	N	19.6	27.0	56.0
1.510000	29.1	Off	N	19.6	26.9	56.0
13.558000	46.8	Off	N	19.8	13.2	60.0
27.118000	32.8	Off	N	20.1	27.2	60.0

Final Result : Average

Frequency (MHz)	Average (dBµV)	Filter	Line	Corr. (dB)	Margin (dB)	Limit (dBµV)
0.166000	37.3	Off	N	19.6	17.9	55.2
0.214000	31.4	Off	N	19.6	21.6	53.0
0.238000	28.0	Off	N	19.6	24.2	52.2
0.478000	32.5	Off	N	19.6	13.9	46.4
0.726000	19.5	Off	N	19.6	26.5	46.0
0.950000	23.6	Off	N	19.6	22.4	46.0
1.510000	23.9	Off	N	19.6	22.1	46.0
13.558000	45.9	Off	N	19.8	4.1	50.0
27.118000	30.1	Off	N	20.1	19.9	50.0



(1) with antenna

Remark: 13.558MHz is the NFC RF fundamental signal.

(2) with dummy load

Remark: Only the fundamental NFC signal needs to be retested per C63.4.



Appendix C. Test Results of Conducted Test Items

C.1 Test Result of 20dB Spectrum Bandwidth

Test mode	NFC Tx	Test Frequency (MHz)	13.56
Date: 25.JUL.2016 09:48:13		Date: 25.JUL.2016 09:50:01	
20dB Bandwidth (kHz)	2.660	99% OccupiedBW(kHz)	2.240
Frequency range (MHz)	$f_L > 13.553$	13.55916	Test Result
	$f_H < 13.567$	13.56182	Complies



C.2 Test Result of Frequency Stability

Voltage vs. Frequency Stability		Temperature vs. Frequency Stability		
Voltage (Vac)	Measurement Frequency (MHz)	Temperature (°C)	Time	Measurement Frequency (MHz)
3.3	13.560490	-20	0	13.560580
			2	13.560580
			5	13.560580
			10	13.560580
2.805	13.560490	-10	0	13.560590
			2	13.560590
			5	13.560590
			10	13.560590
3.795	13.560490	0	0	13.560580
			2	13.560600
			5	13.560600
			10	13.560580
		10	0	13.560560
			2	13.560560
			5	13.560560
			10	13.560540
		20	0	13.560520
			2	13.560520
			5	13.560520
			10	13.560520
		30	0	13.560480
			2	13.560480
			5	13.560480
			10	13.560480
		40	0	13.560480
			2	13.560480
			5	13.560480
			10	13.560460



Voltage vs. Frequency Stability		Temperature vs. Frequency Stability		
Voltage (Vac)	Measurement Frequency (MHz)	Temperature (°C)	Time	Measurement Frequency (MHz)
		50	0	13.560480
			2	13.560460
			5	13.560460
			10	13.560460
Max.Deviation (MHz)	0.000490	Max.Deviation (MHz)	0.000600	
Max.Deviation (ppm)	36.1357	Max.Deviation (ppm)	44.2478	
Limit	FS < ±100 ppm	Limit	FS < ±100 ppm	
Test Result	PASS	Test Result	PASS	



Appendix D. Test Results of Radiated Test Items

D.1 Test Result of Field Strength of Fundamental Emissions

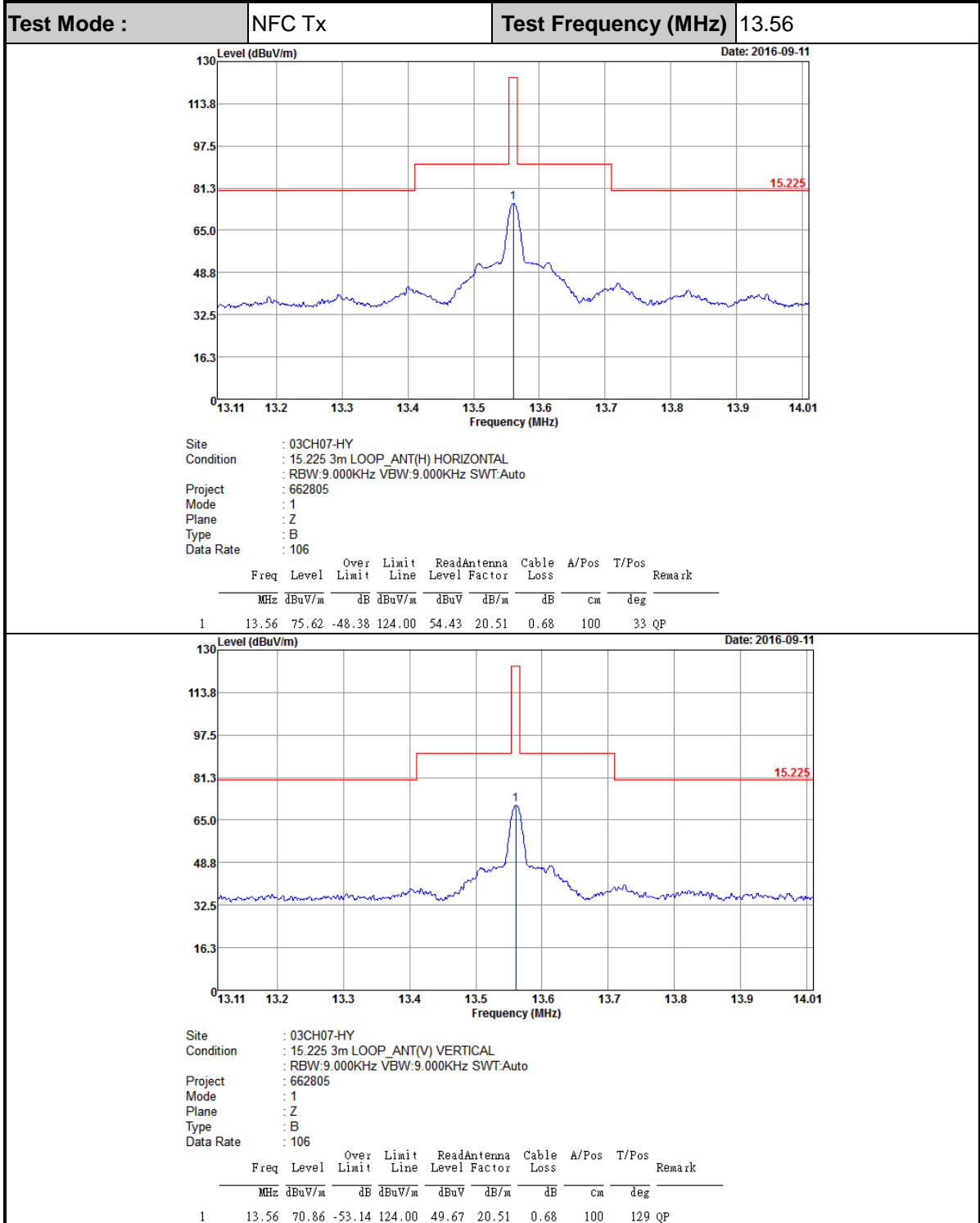

Note: All NFC's spurious emissions are below 20dB of limits.



D.2 Results of Radiated Emissions (9 kHz~30MHz)

Test Mode :		NFC Tx			Polarization :		Horizontal		
Frequency (MHz)	Level (dBμV/m)	Over Limit (dB)	Limit Line (dBμV/m)	Read Level (dBμV)	Antenna Factor (dB)	Cable Loss (dB)	Ant Pos (cm)	Table Pos (deg)	Remark
0.01002	46.64	-80.95	127.59	23.06	22.9	0.68	-	-	Average
0.07557	49.94	-60.1	110.04	30.26	19	0.68	-	-	Average
0.09374	40.24	-67.93	108.17	20.76	18.8	0.68	-	-	QP
0.1192	50	-56.08	106.08	30.53	18.79	0.68	-	-	Average
0.19182	58.53	-43.42	101.95	39.09	18.76	0.68	-	-	Average
0.59514	48.01	-24.1	72.11	28.66	18.67	0.68	100	0	QP
10.096	37.25	-32.25	69.5	16.75	19.82	0.68	-	-	QP
13.56	74.93	5.43	69.5	53.74	20.51	0.68	-	-	QP
21.823	38.6	-30.9	69.5	15.62	21.91	1.07	-	-	QP
29.27	40.31	-29.19	69.5	16.88	22.36	1.07	-	-	QP

Test Mode :		NFC Tx			Polarization :		Vertical		
Frequency (MHz)	Level (dBμV/m)	Over Limit (dB)	Limit Line (dBμV/m)	Read Level (dBμV)	Antenna Factor (dB)	Cable Loss (dB)	Ant Pos (cm)	Table Pos (deg)	Remark
0.01308	49.43	-75.84	125.27	25.85	22.9	0.68	-	-	Average
0.07506	50.58	-59.52	110.1	30.9	19	0.68	-	-	Average
0.0998	37.8	-69.82	107.62	18.32	18.8	0.68	-	-	QP
0.11916	49.75	-56.33	106.08	30.28	18.79	0.68	-	-	Average
0.19046	53.72	-48.29	102.01	34.28	18.76	0.68	-	-	Average
0.51253	42.99	-30.42	73.41	23.69	18.62	0.68	-	-	QP
11.424	37.26	-32.24	69.5	16.49	20.09	0.68	-	-	QP
13.56	70.65	1.15	69.5	49.46	20.51	0.68	-	-	QP
22.282	38.84	-30.66	69.5	15.83	21.94	1.07	-	-	QP
26.7	39.39	-30.11	69.5	16.12	22.2	1.07	100	0	QP

Note:

1. 13.56 MHz is fundamental signal which can be ignored.
2. The amplitude of spurious emissions which are attenuated by more than 20dB below the permissible value has no need to be reported.
3. Distance extrapolation factor = 40 log (specific distance / test distance) (dB);
4. Limit line = specific limits (dBμV) + distance extrapolation factor.



D.3 Results of Radiated Emissions (30MHz~1GHz)

Test Mode :		NFC Tx				Polarization :		Horizontal			
Frequency (MHz)	Level (dBμV/m)	Over Limit (dB)	Limit Line (dBμV/m)	Read Level (dBμV)	Antenna Factor (dB)	Cable Loss (dB)	Preamp Factor (dB)	Ant Pos (cm)	Table Pos (deg)	Remark	
54.3	32.4	-7.6	40	49.06	13.86	1.07	31.59	-	-	Peak	
176.34	39.25	-4.25	43.5	53.34	15.62	1.78	31.49	-	-	Peak	
230.34	42.17	-3.83	46	54.24	17.28	2.07	31.42	100	0	Peak	
420.4	38.4	-7.6	46	43.97	22.68	2.89	31.14	-	-	Peak	
705.3	35.73	-10.27	46	36.22	26.48	3.74	30.71	-	-	Peak	
840.4	37.94	-8.06	46	35.91	28.5	4.1	30.57	-	-	Peak	

Test Mode :		NFC Tx				Polarization :		Vertical			
Frequency (MHz)	Level (dBμV/m)	Over Limit (dB)	Limit Line (dBμV/m)	Read Level (dBμV)	Antenna Factor (dB)	Cable Loss (dB)	Preamp Factor (dB)	Ant Pos (cm)	Table Pos (deg)	Remark	
31.89	35.65	-4.35	40	41.04	24.92	1.07	31.38	-	-	Peak	
176.34	39.53	-3.97	43.5	53.62	15.62	1.78	31.49	100	130	Peak	
244.11	37.04	-8.96	46	47.91	18.45	2.07	31.39	-	-	Peak	
420.4	35.62	-10.38	46	41.19	22.68	2.89	31.14	-	-	Peak	
732.6	33.49	-12.51	46	33.51	26.92	3.74	30.68	-	-	Peak	
948.9	33.95	-12.05	46	30.23	30.18	4.07	30.53	-	-	Peak	

Note:

1. The amplitude of spurious emissions which are attenuated by more than 20dB below the permissible value has no need to be reported.
2. Emission level (dBμV/m) = 20 log Emission level (μV/m).
3. Corrected Reading: Antenna Factor + Cable Loss + Read Level - Preamp Factor= Level.