



FCC & IC RADIO TEST REPORT

Prepared For	MAG DIGITAL LIMITED
Product Name:	8 inch Tablet
Trade Name:	N/A
Model Name :	UBT081X, UBT097X,PTT-826M
FCC ID:	N80-MDUBT01
IC:	10357A-MDUBT01
Prepared By	DongGuan Precise Testing Service Co.,Ltd.
	F616A Room, 6th Floor, Meixin Business Center, Dongcheng Middle Road, Dongguan, Guangdong, China
Test Date:	May 02 ~ May 08, 2012
Date of Report :	May 08, 2012

DongGuan Precise Testing Service Co.,Ltd.

F616A Room, 6th Floor, Meixin Business Center, Dongcheng Middle Road, Dongguan, Guangdong, China
Tel: 86-769-23368601 Fax: 86-769-23368602 [http:// www.pts-testing.com](http://www.pts-testing.com)



VERIFICATION OF COMPLIANCE

Applicant:	MAG DIGITAL LIMITED
Address	Rm918, East Baihuo Palza No 3020. ShenNan East Road, Luohu District, Shenzhen, China
Manufacturer Name:	MAG DIGITAL LIMITED
Address:	Rm918, East Baihuo Palza No 3020. ShenNan East Road, Luohu District, Shenzhen, China
Product Description:	8 inch Tablet
Brand Name:	N/A
Model Name:	UBT081X, UBT097X,PTT-826M
Model difference:	All the same, except for model name
Test procedure	ANSI C63.4 : 2003, RSS-Gen Issue 3
Standards	FCC Part15.247, RSS-210 Issue 8

Prepared by :

Assistant

Reviewer :

Supervisor

Approved & Authorized Signer :

Jack Ou / Manager

DongGuan Precise Testing Service Co.,Ltd.



TABLE OF CONTENTS

- 1. GENERAL INFORMATION 5**
 - 1.1 PRODUCT DESCRIPTION5
 - 1.2 TABLE OF CARRIER FREQUENCYS5
 - 1.3 RELATED SUBMITTAL(S) / GRANT (S)6
 - 1.4 TEST METHODOLOGY6
 - 1.5 TEST FACILITY6
 - 1.6 SPECIAL ACCESSORIES6
 - 1.7 EQUIPMENT MODIFICATIONS6
- 2. SYSTEM TEST CONFIGURATION..... 7**
 - 2.1 CONFIGURATION OF TESTED SYSTEM7
 - 2.2 EQUIPMENT USED IN TESTED SYSTEM7
- 3. SUMMARY OF TEST RESULTS 8**
- 4. DESCRIPTION OF TEST MODES 9**
- 5. CONDUCTION EMISSIONS..... 10**
 - 5.1 MEASUREMENT PROCEDURE: 10
 - 5.2 TEST SET-UP (BLOCK DIAGRAM OF CONFIGURATION) 10
 - 5.3 MEASUREMENT EQUIPMENT USED: 11
 - 5.4 LIMITS AND MEASUREMENT RESULT: 12
- 6. MAXIMUM OUTPUT POWER 15**
 - 6.1 MEASUREMENT PROCEDURE: 15
 - 6.2 TEST SET-UP (BLOCK DIAGRAM OF CONFIGURATION)..... 15
 - 6.3 MEASUREMENT EQUIPMENT USED (RADIATED EMISSION):..... 18
 - 6.4 LIMITS AND MEASUREMENT RESULT:..... 19
- 7. 6 DB BANDWIDTH..... 20**
 - 7.1 MEASUREMENT PROCEDURE 20
 - 7.2 TEST SET-UP (BLOCK DIAGRAM OF CONFIGURATION)..... 20
 - 7.3 MEASUREMENT EQUIPMENT USED:..... 20
 - 7.4 LIMITS AND MEASUREMENT RESULTS: 20
- 8. MAXIMUM CONDUCTED OUTPUT POWER SPECTRAL DENSITY 25**
 - 8.1 MEASUREMENT PROCEDURE: 25
 - 8.2 TEST SET-UP (BLOCK DIAGRAM OF CONFIGURATION)..... 25

DongGuan Precise Testing Service Co.,Ltd.



8.3 MEASUREMENT EQUIPMENT USED:.....25
8.4 LIMITS AND MEASUREMENT RESULT:.....25
9. RADIATED EMISSION..... 30
10. ANTENNA REQUIREMENT 54
PPENDIX 1..... 55
PHOTOGRAPHS OF THE TEST SETUP..... 55
PHOTOGRAPHS OF THE TEST SETUP (>1GHZ)..... 56

DongGuan Precise Testing Service Co.,Ltd.

F616A Room, 6th Floor, Meixin Business Center, Dongcheng Middle Road, Dongguan, Guangdong, China
Tel: 86-769-23368601 Fax: 86-769-23368602 [http:// www.pts-testing.com](http://www.pts-testing.com)



1. GENERAL INFORMATION

1.1 PRODUCT DESCRIPTION

A major technical description of EUT is described as following:

Operation Frequency	2.412 GHz to 2.462GHz
Output Power	802.11b: 12.06dBm(Max) 802.11g: 9.87dBm(Max)
Modulation Type:	802.11b: DSSS (BPSK, QPSK, CCK) 802.11g: OFDM (BPSK, QPSK, 16QAM, 64QAM)
Bit Rate of Transmitter	802.11b:11/5.5/2/1 Mbps 802.11g:54/48/36/24/18/12/9/6 Mbps
Number of channels	11
Antenna Designation	Integrated Antenna
Antenna Gain	0.52 dbi
Power Supply	DC 3.7V (2 cell)by battery
ADAPTER:	Model: SK02G-0520200U, AC Power Input: 100-240V~, 50/60Hz, 0.35A Max Output: 5.2V \equiv 2A
Based on the application, features, or specification exhibited in User's Manual, the EUT is considered as an ITE/Computing Device. More details of EUT technical specification, please refer to the User's Manual.	

1.2 TABLE OF CARRIER FREQUENCIES

Channel List							
Channel	Frequen cy (MHz)	Channel	Frequen cy (MHz)	Channel	Frequen cy (MHz)	Channel	Frequen cy (MHz)
01	2412	04	2427	07	2442	10	2457
02	2417	05	2432	08	2447	11	2462
03	2422	06	2437	09	2452		

DongGuan Precise Testing Service Co.,Ltd.

F616A Room, 6th Floor, Meixin Business Center, Dongcheng Middle Road, Dongguan, Guangdong, China
Tel: 86-769-23368601 Fax: 86-769-23368602 [http:// www.pts-testing.com](http://www.pts-testing.com)



1.3 RELATED SUBMITTAL(S) / GRANT (S)

According to the specifications of the manufacturer, the EUT must comply with the requirements of the following standards:

- ♦ FCC Part 15 Subpart C §15.247
- ♦ FCC KDB Publication No. 558074 D01 DTS Meas. Guidance v01
- ♦ ANSI C63.4-2003
- ♦ IC RSS-210 Issue 8
- ♦ IC RSS-Gen Issue 3

1.4 TEST METHODOLOGY

Both conducted and radiated testing were performed according to the procedures in ANSI C63.4 (2003). Radiated testing was performed at an antenna to EUT distance 3 meters.

1.5 TEST FACILITY

All measurement facilities used to collect the measurement data are located at NTEK Testing Technology Co., Ltd
1/F, Building E, Fenda Science Park, Sanwei Community, Xixiang Street, Bao'an District, Shenzhen P.R. China.

The test site is constructed and calibrated to meet the FCC requirements in documents ANSI C63.4: 2003.
FCC register No.: 238937
IC register No.: 9270A-1

Radiated emissions are measured with one or more of the following types of linearly polarized antennas: tuned dipole, biconical, log periodic, bi-log, and/or ridged waveguide, horn. Spectrum analyzers with preselectors and quasi-peak detectors are used to perform radiated measurements.

1.6 SPECIAL ACCESSORIES

Not available for this EUT intended for grant.

1.7 EQUIPMENT MODIFICATIONS

Not available for this EUT intended for grant.



2. SYSTEM TEST CONFIGURATION

2.1 CONFIGURATION OF TESTED SYSTEM

Conducted Emission:

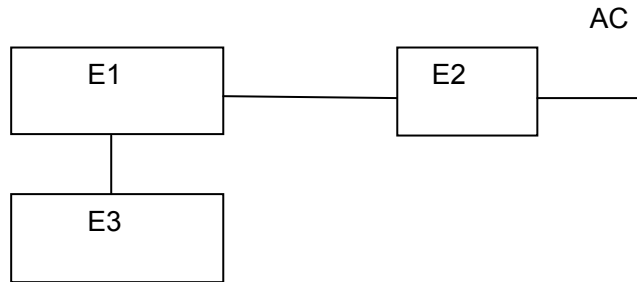

Radiated Emission:

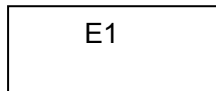

2.2 EQUIPMENT USED IN TESTED SYSTEM

Item	Equipment	Mfr/Brand	Model/Type No.	FCC ID
E1	8 inch Tablet	N/A	UBT081X	N80-MDUBT01
E2	ADAPTER	SIMSUKIAN	SK02G-0520200U	--
E3	Earphone	N/A	6231	--

DongGuan Precise Testing Service Co.,Ltd.

F616A Room, 6th Floor, Meixin Business Center, Dongcheng Middle Road, Dongguan, Guangdong, China
Tel: 86-769-23368601 Fax: 86-769-23368602 [http:// www.pts-testing.com](http://www.pts-testing.com)



3. SUMMARY OF TEST RESULTS

FCC Part15, Subpart C(15.247), RSS-Gen Issue 3 & RSS-210 Issue 8			
Standard Section	Test Item	Judgment	Remark
15.207&7.2.4	Conducted Emission	PASS	
15.205&A8.5	Band Edge Emission	PASS	
15.247(a)(1)&A8.2	6dB Bandwidth	PASS	
15.247(b)(1)&A8.4	Peak Output Power	PASS	
15.247(c)&A8.5	Radiated Spurious Emission	PASS	
15.247 (d) &A8.4	Power Spectral Density	PASS	
15.203	Antenna Requirement	PASS	
1.1307 1.1310 2.1091 2.1093	RF Exposure Compliance	PASS	

DongGuan Precise Testing Service Co.,Ltd.

F616A Room, 6th Floor, Meixin Business Center, Dongcheng Middle Road, Dongguan, Guangdong, China
Tel: 86-769-23368601 Fax: 86-769-23368602 [http:// www.pts-testing.com](http://www.pts-testing.com)



4. DESCRIPTION OF TEST MODES

To investigate the maximum EMI emission characteristics generates from EUT, the test system was pre-scanning tested base on the consideration of following EUT operation mode or test configuration mode which possible have effect on EMI emission level. Each of these EUT operation mode(s) or test configuration mode(s) mentioned above was evaluated respectively.

Pretest Mode	Description
Mode 1	802.11b CH1/ CH6/ CH11
Mode 2	802.11g CH1/ CH6/ CH11
Mode 3	Charging

For Conducted Emission	
Final Test Mode	Description
Mode 3	Charging

For Radiated Emission	
Final Test Mode	Description
Mode 1	802.11b CH1/ CH6/ CH11
Mode 2	802.11g CH1/ CH6/ CH11

Note:

- (1) The measurements are performed at the highest, middle, lowest available channels.
- (2) The measurements are performed at all Bit Rate of Transmitter, the worst data was reported
- (3) Both horizontal and vertical antenna polarities were tested,and performed pretest to three orthogonal axis. The worst case emissions were reported

DongGuan Precise Testing Service Co.,Ltd.



5. CONDUCTION EMISSIONS

5.1 MEASUREMENT PROCEDURE:

1. The equipment was set up as per the test configuration to simulate typical actual usage per the user's manual. The EUT is a tabletop system; a wooden table with a height of 0.8 meters is used and is placed on the ground plane as per ANSI C63.4.
2. Support equipment, if needed, was placed as per ANSI C63.4.
3. All I/O cables were positioned to simulate typical actual usage as per ANSI C63.4.
4. The EUT received AC120V through a Line Impedance Stabilization Network (LISN) which supplied power source and was grounded to the ground plane.
5. All support equipments received AC power from a second LISN, if any.
6. The EUT test program was started. Emissions were measured on each current carrying line of the EUT using a spectrum Analyzer / Receiver connected to the LISN powering the EUT. The LISN has two monitoring points: Line 1 (Hot Side) and Line 2 (Neutral Side). Two scans were taken: one with Line 1 connected to Analyzer / Receiver and Line 2 connected to a 50 ohm load; the second scan had Line 1 connected to a 50 ohm load and Line 2 connected to the Analyzer / Receiver.
7. Analyzer / Receiver scanned from 150 KHz to 30MHz for emissions in each of the test modes.
8. During the above scans, the emissions were maximized by cable manipulation.

5.2 TEST SET-UP (BLOCK DIAGRAM OF CONFIGURATION)

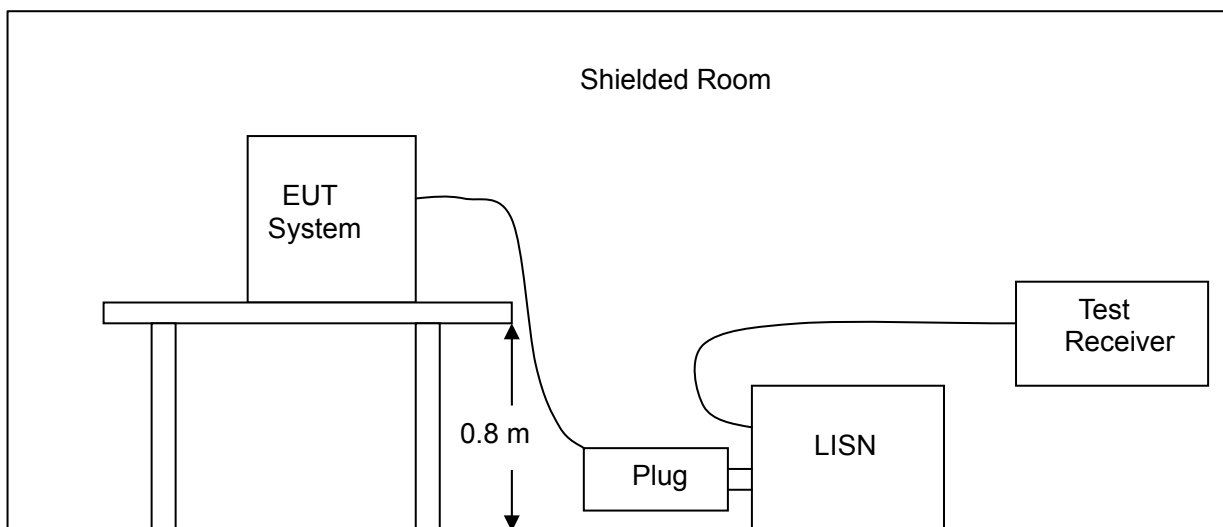

DongGuan Precise Testing Service Co.,Ltd.

F616A Room, 6th Floor, Meixin Business Center, Dongcheng Middle Road, Dongguan, Guangdong, China
Tel: 86-769-23368601 Fax: 86-769-23368602 [http:// www.pts-testing.com](http://www.pts-testing.com)



5.3 MEASUREMENT EQUIPMENT USED:

Item	Kind of Equipment	Manufacturer	Type No.	Serial No.	Calibrated until
1	Test Receiver	R&S	ESCI	101160	Jul. 06. 2012
2	LISN	R&S	ENV216	101313	Jul. 06. 2012
3	LISN	EMCO	3816/2	00042990	Jul. 06. 2012
4	50Ω Coaxial Switch	Anritsu	MP59B	6200264417	Jul. 06. 2012
5	Passive Voltage Probe	R&S	ESH2-Z3	100196	Jul. 06. 2012
6	Absorbing clamp	R&S	MOS-21	100423	Jul. 06. 2012

DongGuan Precise Testing Service Co.,Ltd.

F616A Room, 6th Floor, Meixin Business Center, Dongcheng Middle Road, Dongguan, Guangdong, China
Tel: 86-769-23368601 Fax: 86-769-23368602 [http:// www.pts-testing.com](http://www.pts-testing.com)

**5.4 LIMITS AND MEASUREMENT RESULT:****LIMITS OF LINE CONDUCTED EMISSION TEST**

Frequency	Maximum RF Line Voltage	
	Q.P.(dBuV)	Average(dBuV)
150kHz~500kHz	66-56	56-46
500kHz~5MHz	56	46
5MHz~30MHz	60	50

- 1**Note: 1. The lower limit shall apply at the transition frequency.
 2. The limit decreases linearly with the logarithm of the frequency in the range 0.15 MHz to 0.50 MHz

MEASURING INSTRUMENT AND SETTING

The following table is the setting of receiver.

Receiver Parameter	Setting
Attenuation	10dB
Start Frequency	0.15MHz
Stop Frequency	30MHz
6dB bandwidth	9KHz for QP
IF bandwidth	9KHz for AV

TEST RESULT**DongGuan Precise Testing Service Co.,Ltd.**

F616A Room, 6th Floor, Meixin Business Center, Dongcheng Middle Road, Dongguan, Guangdong, China
 Tel: 86-769-23368601 Fax: 86-769-23368602 [http:// www.pts-testing.com](http://www.pts-testing.com)



LINE CONDUCTED EMISSION TEST LINE 1-L

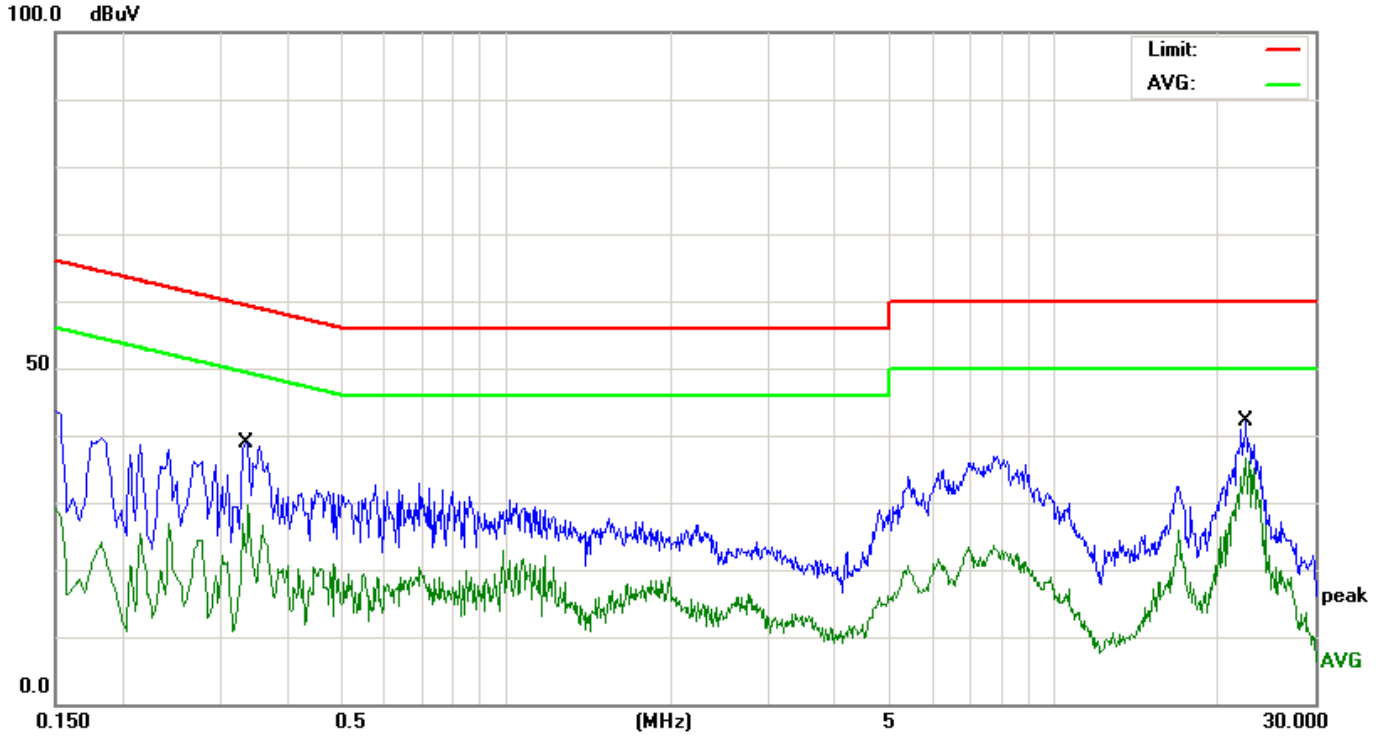

Freq. (MHz)	Reading (dBuV)	Factor (dBuV)	Measurement (dBuV)	Limit (dBuV)	Over (dB)	Detector
0.3339	28.56	10.42	38.98	59.35	-20.37	QP
0.3379	19.25	10.42	29.67	49.25	-19.58	AVG
22.346	25.97	10.73	36.7	50	-13.3	AVG
22.45	31.27	10.73	42	60	-18	QP

DongGuan Precise Testing Service Co.,Ltd.

F616A Room, 6th Floor, Meixin Business Center, Dongcheng Middle Road, Dongguan, Guangdong, China
 Tel: 86-769-23368601 Fax: 86-769-23368602 [http:// www.pts-testing.com](http://www.pts-testing.com)



LINE CONDUCTED EMISSION TEST LINE 2-N

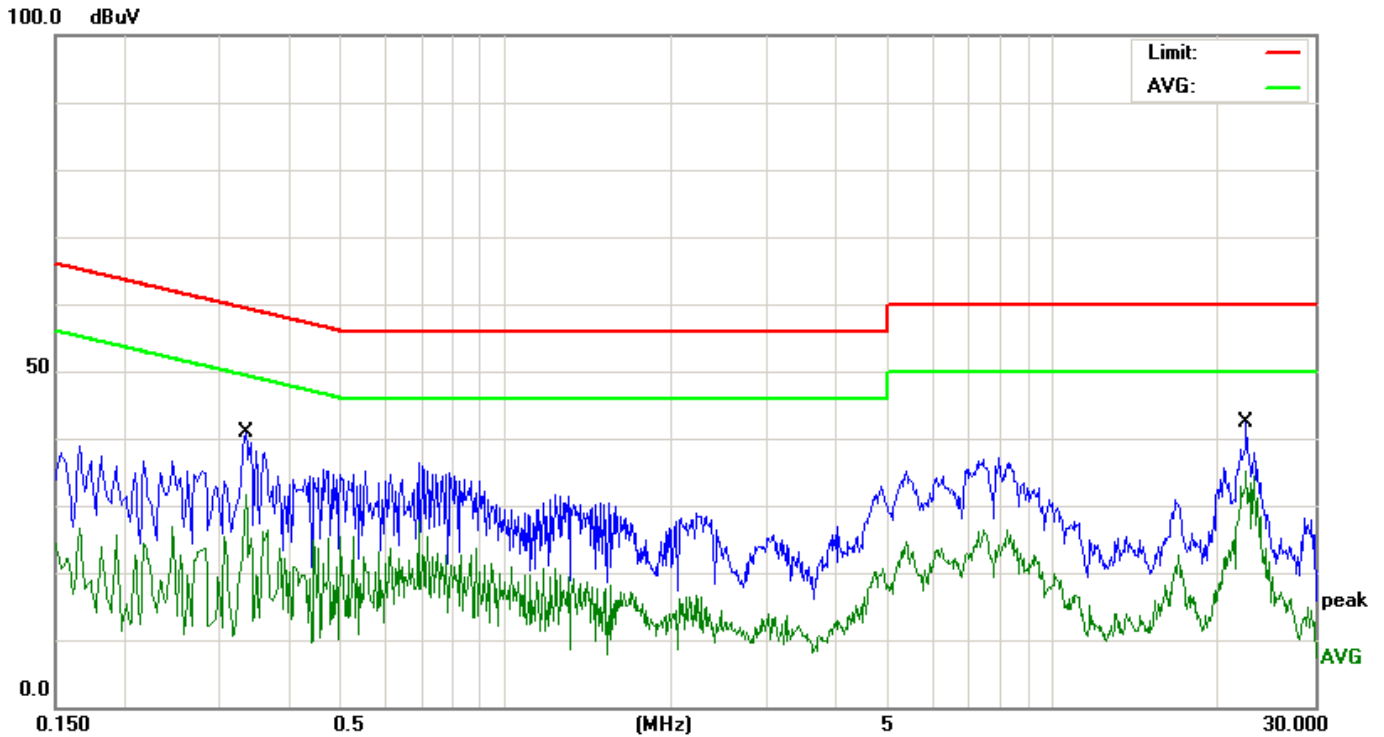

Freq. (MHz)	Reading (dBuV)	Factor (dBuV)	Measurement (dBuV)	Limit (dBuV)	Over (dB)	Detector
0.3339	30.54	10.42	40.96	59.35	-18.39	QP
0.3339	21.24	10.42	31.66	49.35	-17.69	AVG
22.446	31.54	10.73	42.27	60	-17.73	QP
22.446	24.33	10.73	35.06	50	-14.94	AVG

Remark:

1. All readings are Quasi-Peak and Average values.
2. Factor = Insertion Loss + Cable Loss.

DongGuan Precise Testing Service Co.,Ltd.

F616A Room, 6th Floor, Meixin Business Center, Dongcheng Middle Road, Dongguan, Guangdong, China
 Tel: 86-769-23368601 Fax: 86-769-23368602 [http:// www.pts-testing.com](http://www.pts-testing.com)



6. MAXIMUM OUTPUT POWER

6.1 MEASUREMENT PROCEDURE:

The EUT was directly connected to the Power meter

6.2 TEST SET-UP (BLOCK DIAGRAM OF CONFIGURATION)

CONDUCTED METHOD



RADIATED EMISSION TEST SETUP

RADIATED MISSION TEST SETUP BELOW 30MHz

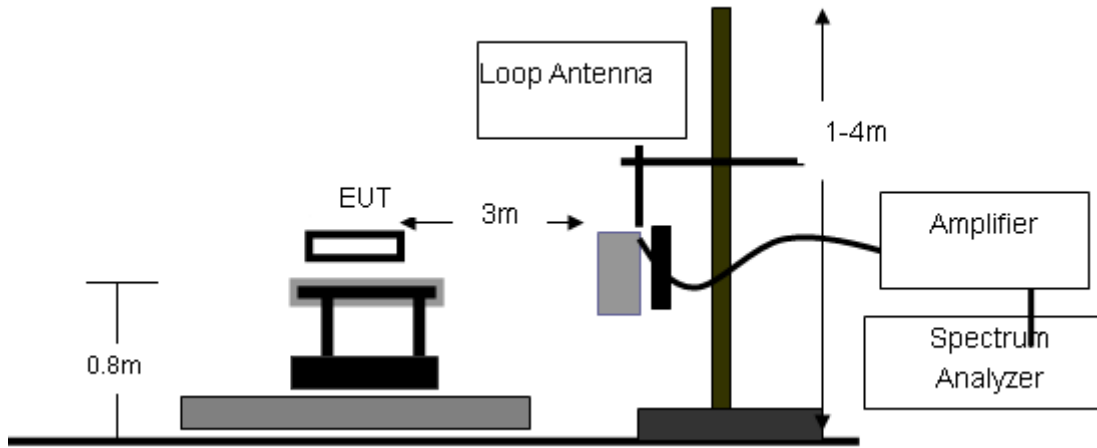

RADIATED MISSION TEST SETUP 30MHz-1000MHz

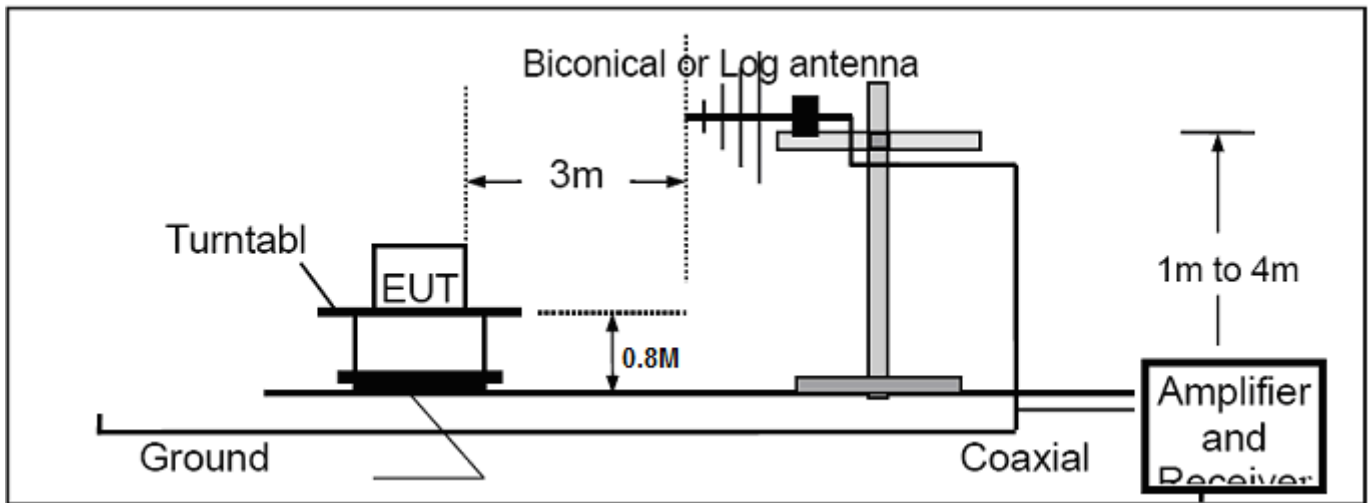



RADIATED MISSION TEST SETUP ABOVE 1000MHz

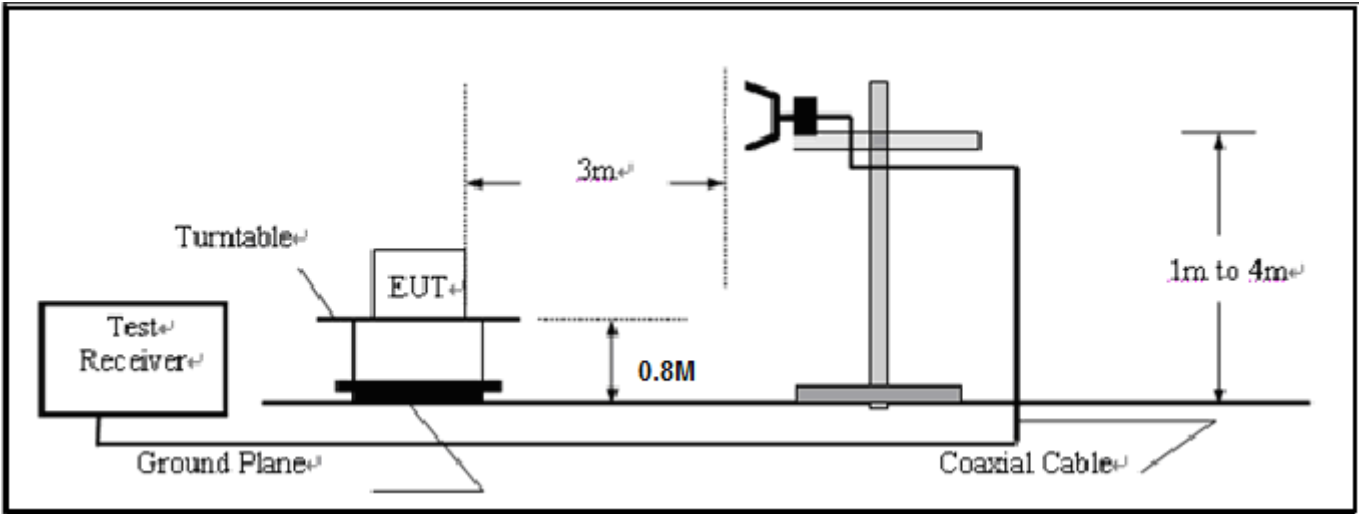

DongGuan Precise Testing Service Co.,Ltd.

F616A Room, 6th Floor, Meixin Business Center, Dongcheng Middle Road, Dongguan, Guangdong, China
Tel: 86-769-23368601 Fax: 86-769-23368602 [http:// www.pts-testing.com](http://www.pts-testing.com)

**6.3 MEASUREMENT EQUIPMENT USED (RADIATED EMISSION):**

Item	Kind of Equipment	Manufacturer	Type No.	Serial No.	Calibrated until
1	Spectrum Analyzer	Agilent	E4407B	160400005	Jul. 06. 2012
2	Test Receiver	R&S	ESPI	101318	Jul. 06. 2012
3	Bilog Antenna	TESEQ	CBL6111D	31216	Jul. 06. 2012
4	50Ω Coaxial Switch	Anritsu	MP59B	6200264416	Jul. 06. 2012
5	Spectrum Analyzer	ADVANTEST	R3132	150900201	Jul. 06. 2012
6	Horn Antenna	EM	EM-AH-10180	2011071402	Jul. 06. 2012
7	Horn Ant	Schwarzbeck	BBHA 9170	9170-181	Jul. 06. 2012
8	Amplifier	EM	EM-30180	060538	Jul. 06. 2012
9	Loop Antenna	ARA	PLA-1030/B	1029	Jul. 06. 2012
10	Power Meter	R&S	NRVS	100696	Jul. 06. 2012

DongGuan Precise Testing Service Co.,Ltd.

F616A Room, 6th Floor, Meixin Business Center, Dongcheng Middle Road, Dongguan, Guangdong, China
Tel: 86-769-23368601 Fax: 86-769-23368602 [http:// www.pts-testing.com](http://www.pts-testing.com)

**6.4 LIMITS AND MEASUREMENT RESULT:**

EUT:	8 inch Tablet	Model Name. :	UBT081X
Temperature:	25 °C	Relative Humidity::	60%
Pressure:	1012 hPa	Test Voltage :	DC3.7V by battery
Test Mode :	802.11b /CH01, CH06, CH11		

Test Channel	Frequency (MHz)	Peak output power (dBm)	LIMIT (dBm)	LIMIT (W)
CH01	2412	12.06	30	1
CH06	2437	11.67	30	1
CH11	2462	10.80	30	1

EUT:	8 inch Tablet	Model Name. :	UBT081X
Temperature:	25 °C	Relative Humidity::	60%
Pressure:	1012 hPa	Test Voltage :	DC3.7V by battery
Test Mode :	802.11g /CH01, CH06, CH11		

Test Channel	Frequency (MHz)	Peak output power (dBm)	LIMIT (dBm)	LIMIT (W)
CH01	2412	9.87	30	1
CH06	2437	9.13	30	1
CH11	2462	8.54	30	1

DongGuan Precise Testing Service Co.,Ltd.

F616A Room, 6th Floor, Meixin Business Center, Dongcheng Middle Road, Dongguan, Guangdong, China
Tel: 86-769-23368601 Fax: 86-769-23368602 [http:// www.pts-testing.com](http://www.pts-testing.com)



7. 6 DB BANDWIDTH

7.1 MEASUREMENT PROCEDURE

1. The testing follows FCC KDB Publication No. 558074 D01 DTS Meas. Guidance v01.
2. The RF output of EUT was connected to the spectrum analyzer by a low loss cable. The path loss was compensated to the results for each measurement.
3. Make the measurement with the spectrum analyzer's resolution bandwidth (RBW) = 1-5% of the emission bandwidth (EBW).Set the Video bandwidth (VBW) ≥ 3 * RBW. In order to make an accurate measurement. The 6 dB bandwidth must be greater than 500 KHz.
4. The marker-delta reading at this point is the 6 dB bandwidth of the emission.

7.2 TEST SET-UP (BLOCK DIAGRAM OF CONFIGURATION)

The Same as described in Section 6.2

7.3 MEASUREMENT EQUIPMENT USED:

The same as described in Section 6.3

7.4 LIMITS AND MEASUREMENT RESULTS:

EUT:	8 inch Tablet	Model Name. :	UBT081X
Temperature:	25 °C	Relative Humidity:	60%
Pressure:	1012 hPa	Test Voltage :	DC 3.7V by battery
Test Mode :	TX B MODE /CH01, CH06, CH11		

Frequency	6dB Bandwidth (MHz)	99% Occupied BW (MHz)	Channel Separation (MHz)	Result
2412 MHz	11.59	14.11	>=500KHz	PASS
2437 MHz	11.56	14.07	>=500KHz	PASS
2462 MHz	11.54	14.15	>=500KHz	PASS

DongGuan Precise Testing Service Co.,Ltd.



TX CH 01

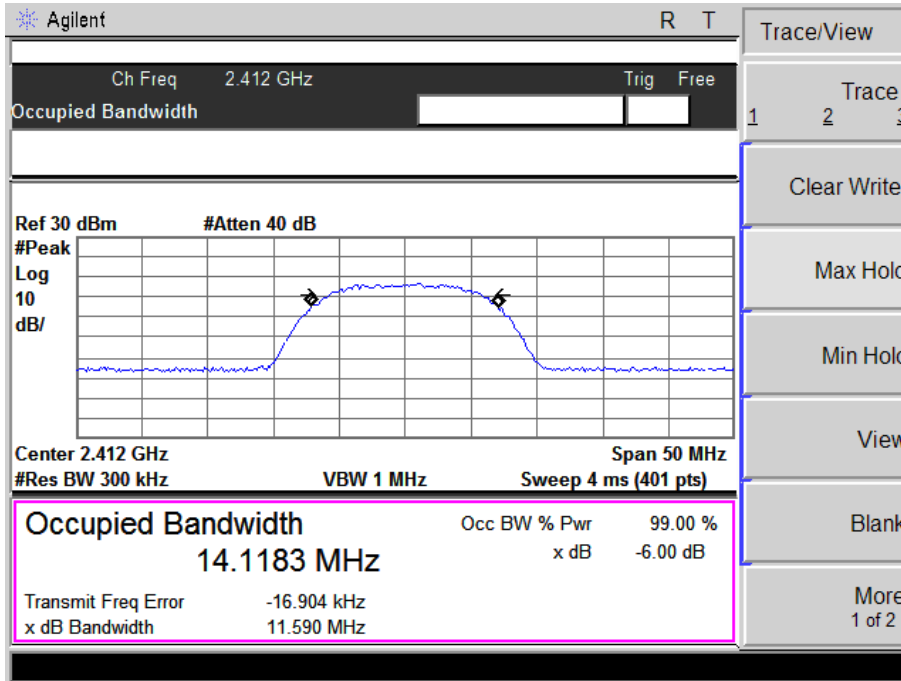

TX CH 06

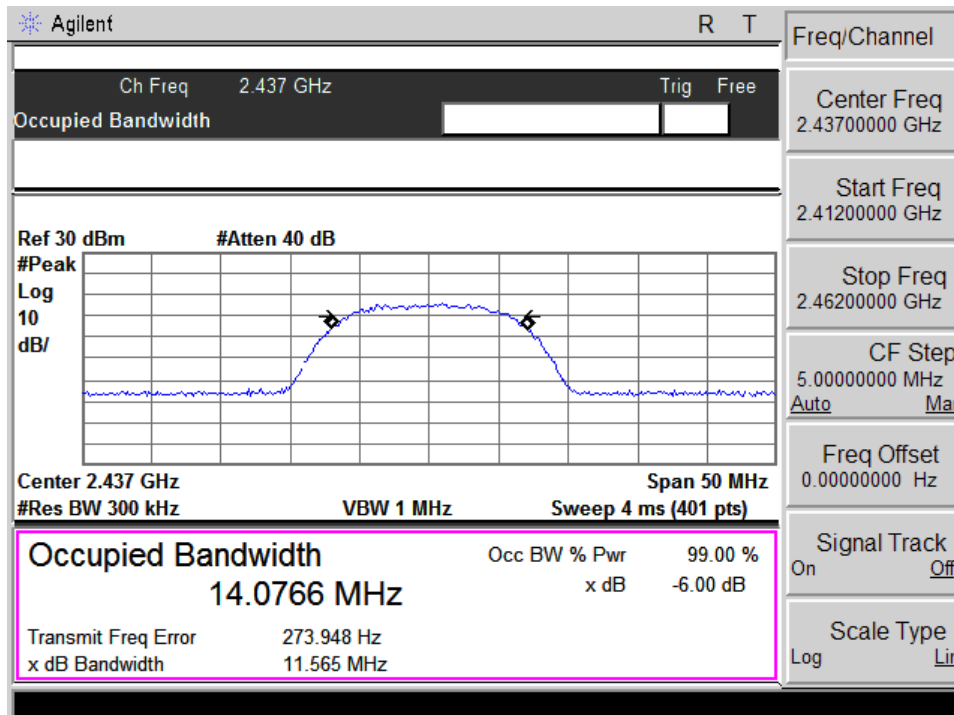

DongGuan Precise Testing Service Co.,Ltd.



TX CH 11

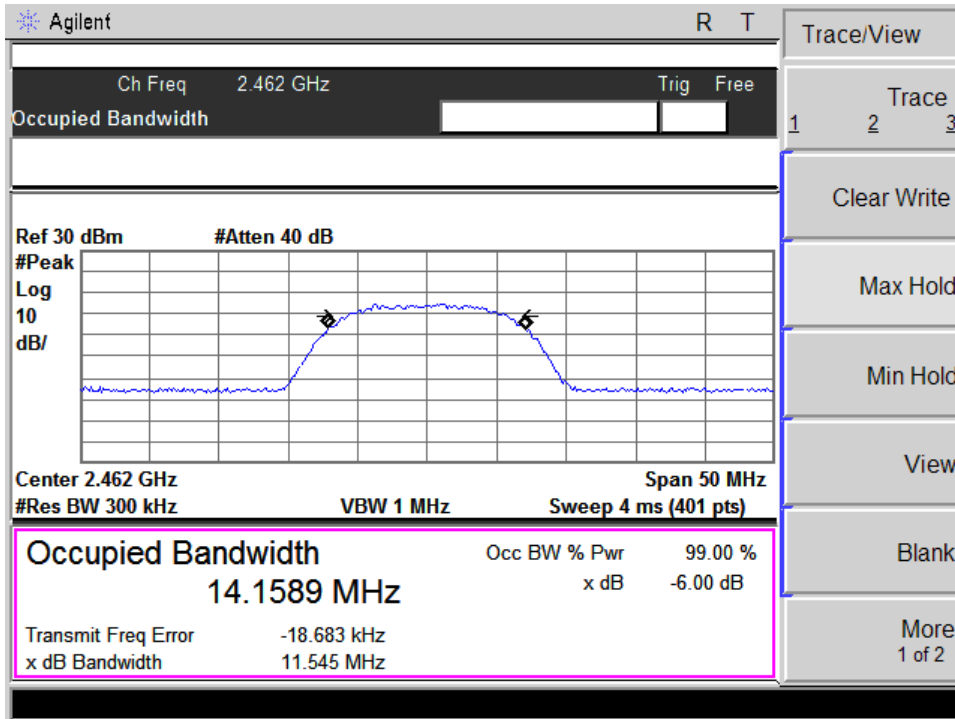

DongGuan Precise Testing Service Co.,Ltd.

F616A Room, 6th Floor, Meixin Business Center, Dongcheng Middle Road, Dongguan, Guangdong, China
Tel: 86-769-23368601 Fax: 86-769-23368602 [http:// www.pts-testing.com](http://www.pts-testing.com)



EUT:	8 inch Tablet	Model Name. :	UBT081X
Temperature:	25 °C	Relative Humidity:	60%
Pressure:	1012 hPa	Test Voltage :	DC 3.7V by battery
Test Mode :	TX G MODE /CH01, CH06, CH11		

Frequency	6dB Bandwidth (MHz)	99% Occupied BW (MHz)	Channel Separation (MHz)	Result
2412 MHz	16.62	16.64	>=500KHz	PASS
2437 MHz	16.56	16.67	>=500KHz	PASS
2462 MHz	16.65	16.65	>=500KHz	PASS

TX CH 01

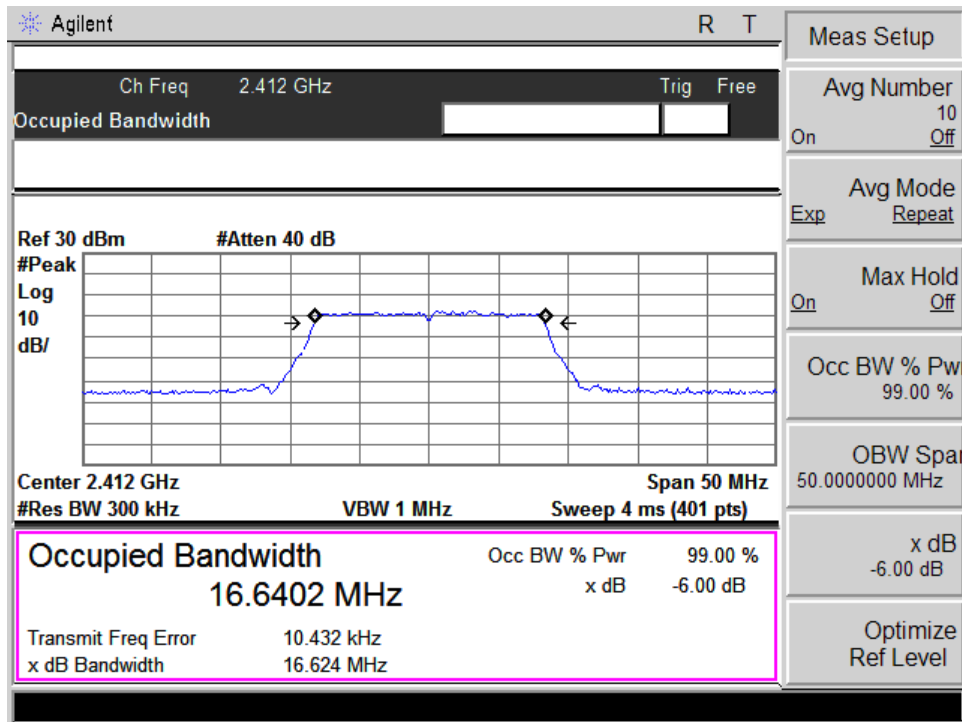

DongGuan Precise Testing Service Co.,Ltd.

F616A Room, 6th Floor, Meixin Business Center, Dongcheng Middle Road, Dongguan, Guangdong, China
 Tel: 86-769-23368601 Fax: 86-769-23368602 http:// www.pts-testing.com



TX CH 06

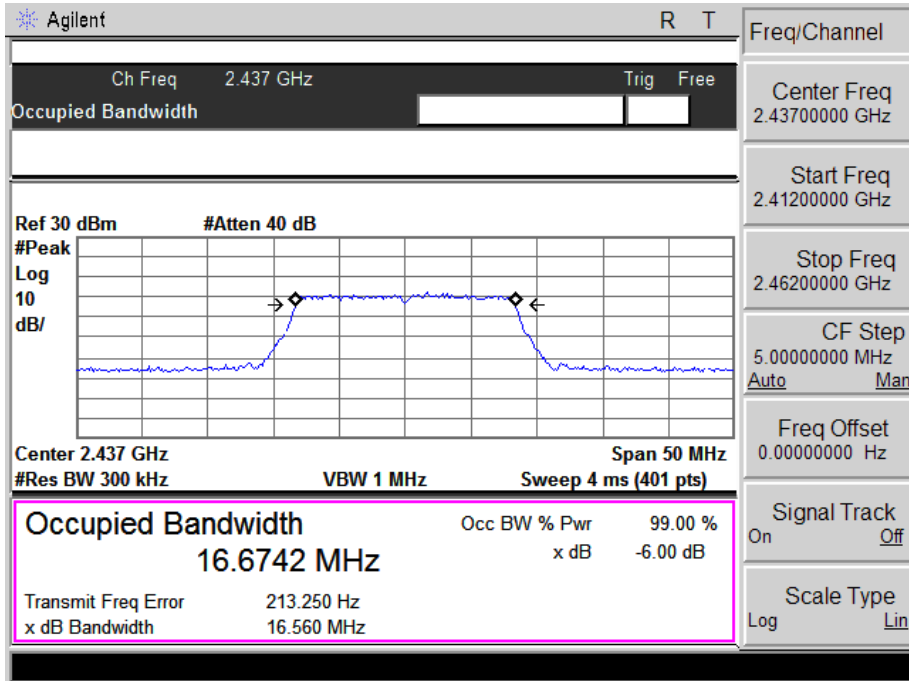

TX CH 11

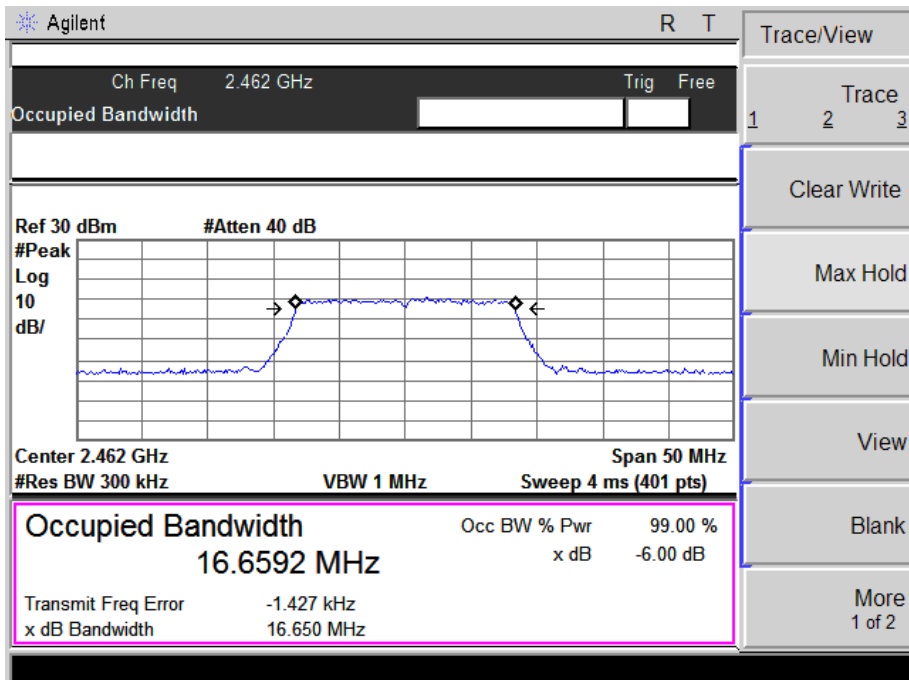

DongGuan Precise Testing Service Co.,Ltd.



8. MAXIMUM CONDUCTED OUTPUT POWER SPECTRAL DENSITY

8.1 MEASUREMENT PROCEDURE:

1. The testing follows Measurement Procedure PKPSD of FCC KDB Publication No. 558074 D01 DTS Meas. Guidance v01.
2. The RF output of EUT was connected to the spectrum analyzer by a low loss cable. The path loss was compensated to the results for each measurement.
3. Record the measurement data derived from spectrum analyzer.
4. Make the measurement with the spectrum analyzer's resolution bandwidth (RBW) = 100 KHz. Video bandwidth (VBW) >= 300 KHz In order to make an accurate measurement, set the span to 5-30% greater than Emission Bandwidth (EBW)
5. Detector = peak, Sweep time = auto couple, Trace mode = max hold, Allow trace to fully stabilize. Use the peak marker function to determine the maximum power level in any 100 kHz band segment within the fundamental EBW.
6. Scale the observed power level to an equivalent value in 3 kHz by adjusting (reducing) the measured power by a bandwidth correction factor (BWCF) where $BWCF = 10\log(3\text{ kHz}/100\text{ kHz}) = -15.2\text{ dB}$.

8.2 TEST SET-UP (BLOCK DIAGRAM OF CONFIGURATION)

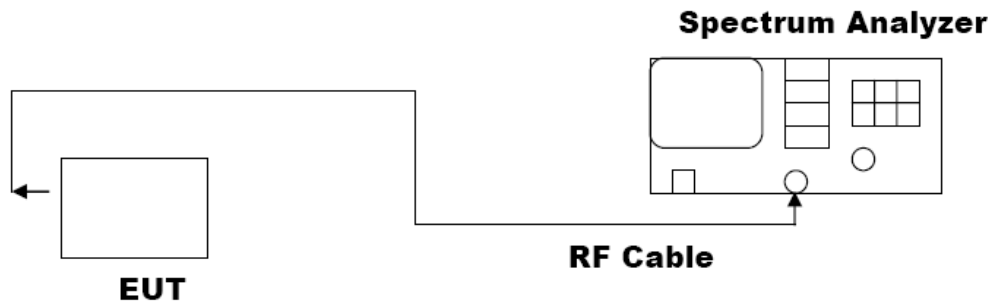

8.3 MEASUREMENT EQUIPMENT USED:

SHIELDING ROOM					
EQUIPMENT TYPE	MFR	MODEL NUMBER	SERIAL NUMBER	LAST CAL.	CAL DUE.
Spectrum Analyzer	Agilent	E4407B	160400005	Jul. 06. 2012	Jul. 06. 2013

8.4 LIMITS AND MEASUREMENT RESULT:

DongGuan Precise Testing Service Co.,Ltd.

F616A Room, 6th Floor, Meixin Business Center, Dongcheng Middle Road, Dongguan, Guangdong, China
 Tel: 86-769-23368601 Fax: 86-769-23368602 [http:// www.pts-testing.com](http://www.pts-testing.com)



EUT:	8 inch Tablet	Model Name. :	UBT081X
Temperature:	25 °C	Relative Humidity:	60%
Pressure:	1015 hPa	Test Voltage :	DC 3.7V by battery
Test Mode :	TX B MODE /CH01, CH06, CH11		

Frequency	Power Density (dBm)	PSD/3KHz (dBm)	Limit (dBm)	Result
2412 MHz	-8.11	-23.31	8	PASS
2437 MHz	-8.97	-24.17	8	PASS
2462 MHz	-9.70	-24.90	8	PASS

TX CH01

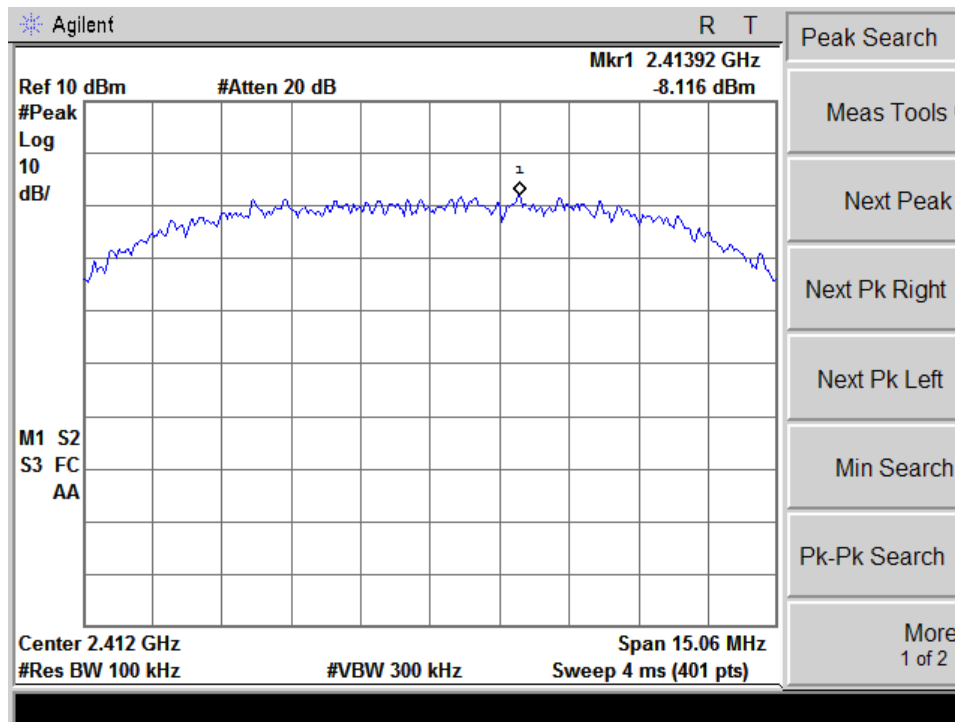

DongGuan Precise Testing Service Co.,Ltd.

F616A Room, 6th Floor, Meixin Business Center, Dongcheng Middle Road, Dongguan, Guangdong, China
 Tel: 86-769-23368601 Fax: 86-769-23368602 http:// www.pts-testing.com



TX CH06

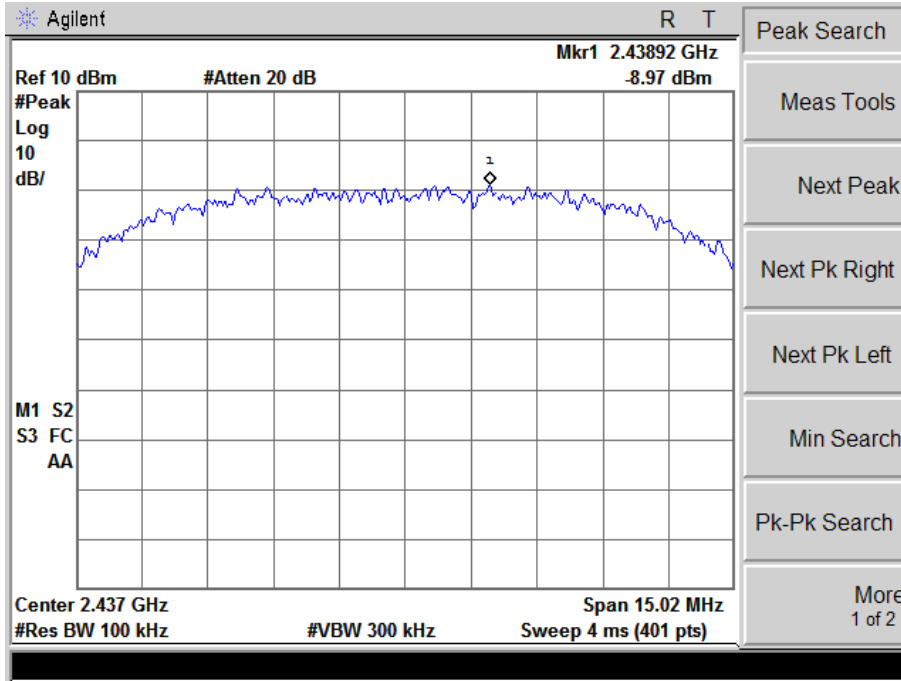

TX CH11

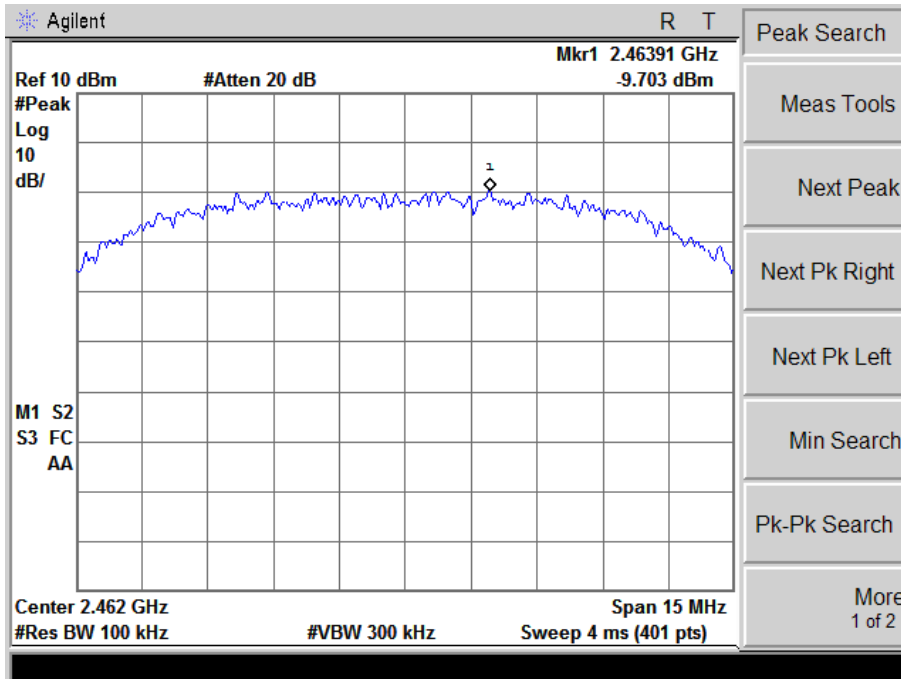

DongGuan Precise Testing Service Co.,Ltd.



EUT:	8 inch Tablet	Model Name. :	UBT081X
Temperature:	25 °C	Relative Humidity:	60%
Pressure:	1015 hPa	Test Voltage :	DC 3.7V by battery
Test Mode :	TX G MODE /CH01, CH06, CH11		

Frequency	Power Density (dBm)	PSD/3KHz (dBm)	Limit (dBm)	Result
2412 MHz	-12.59	-27.79	8	PASS
2437 MHz	-13.77	-28.97	8	PASS
2462 MHz	-13.77	-28.97	8	PASS

TX CH01

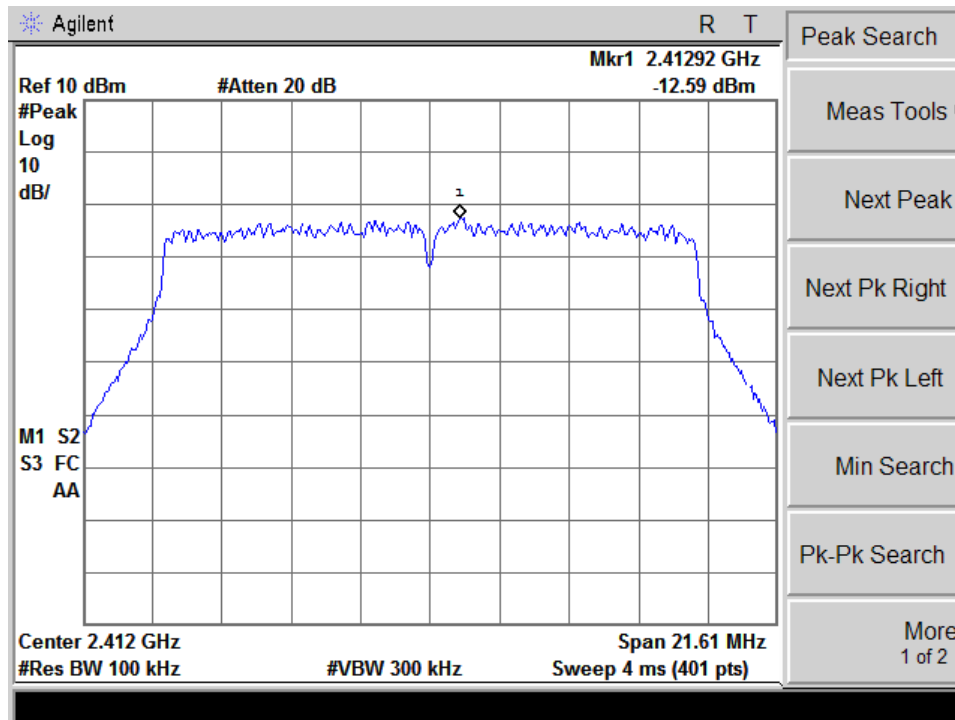

DongGuan Precise Testing Service Co.,Ltd.

F616A Room, 6th Floor, Meixin Business Center, Dongcheng Middle Road, Dongguan, Guangdong, China
 Tel: 86-769-23368601 Fax: 86-769-23368602 [http:// www.pts-testing.com](http://www.pts-testing.com)



TX CH06

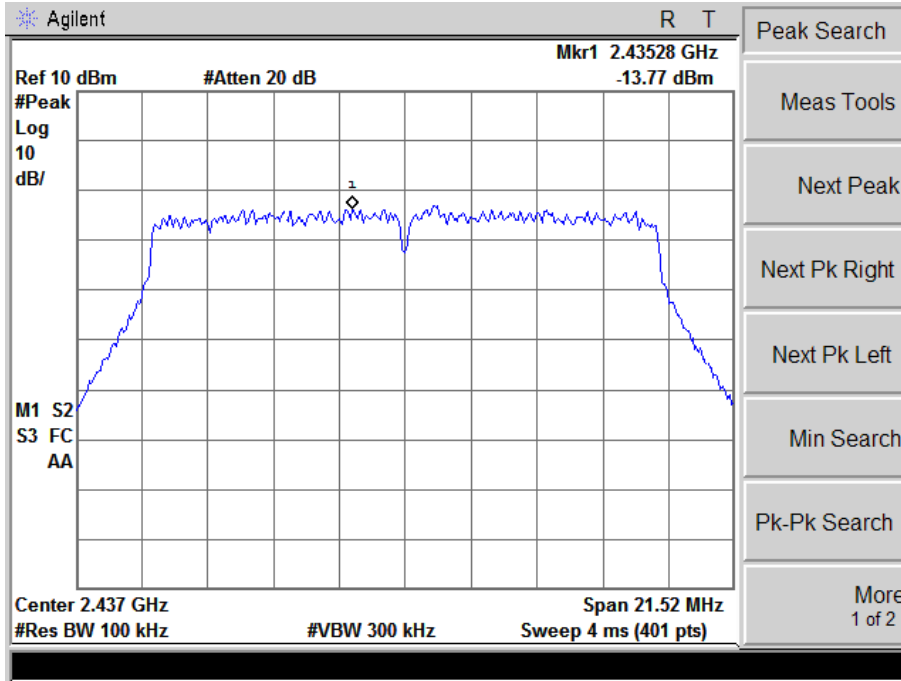

TX CH11

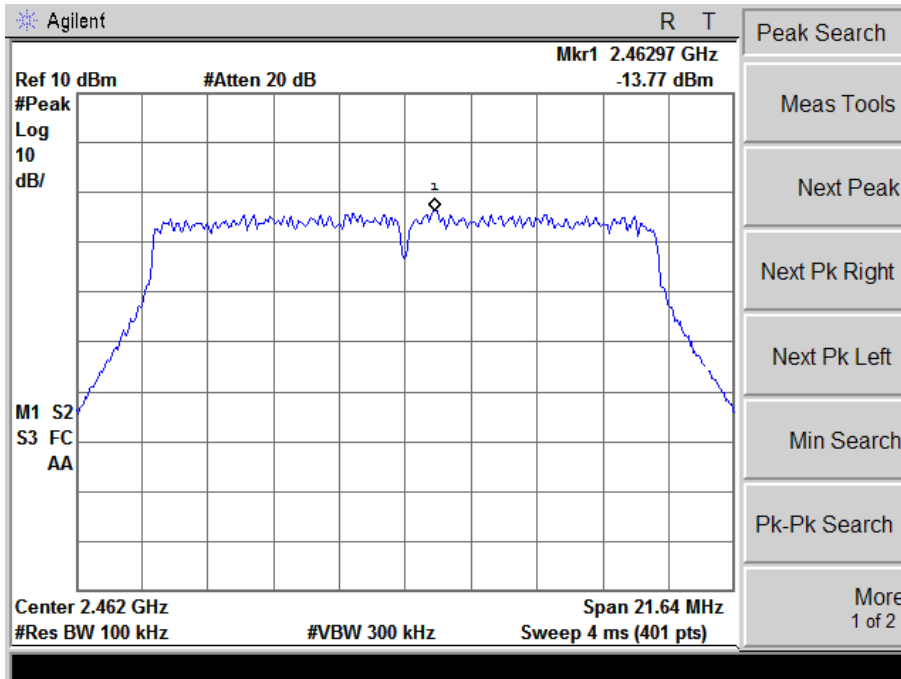

DongGuan Precise Testing Service Co.,Ltd.

F616A Room, 6th Floor, Meixin Business Center, Dongcheng Middle Road, Dongguan, Guangdong, China
Tel: 86-769-23368601 Fax: 86-769-23368602 [http:// www.pts-testing.com](http://www.pts-testing.com)



9. RADIATED EMISSION

MEASUREMENT PROCEDURE

- a. The measuring distance of at 3 m shall be used for measurements at frequency up to 1GHz. For frequencies above 1GHz, any suitable measuring distance may be used.
- b. The EUT was placed on the top of a rotating table 0.8 meters above the ground at a 3 meter open area test site. The table was rotated 360 degrees to determine the position of the highest radiation.
- c. The height of the equipment or of the substitution antenna shall be 0.8 m; the height of the test antenna shall vary between 1 m to 4 m. Both horizontal and vertical polarizations of the antenna are set to make the measurement.
- d. The initial step in collecting conducted emission data is a spectrum analyzer peak detector mode pre-scanning the measurement frequency range. Significant peaks are then marked and then Quasi Peak detector mode re-measured.
- e. If the Peak Mode measured value compliance with and lower than Quasi Peak Mode Limit, the EUT shall be deemed to meet QP Limits and then no additional QP Mode measurement performed.
- f. For the actual test configuration, please refer to the related Item –EUT Test Photos.

Note:

Both horizontal and vertical antenna polarities were tested and performed pretest to three orthogonal axis. The worst case emissions were reported

The following table is the setting of spectrum analyzer and receiver.'

Spectrum Parameter	Setting
Start Frequency	1GHz
Stop Frequency	26.5GHz
RB/VB(Emission in restricted band)	1MHz/1MHz for Peak, 1MHz/10Hz for Average
RB/VB(Emission in non-restricted band)	1MHz/1MHz for Peak

Receiver Parameter	Setting
Start ~Stop Frequency	9KHz~150KHz/RB 200Hz for QP
Start ~Stop Frequency	150KHz~30MHz/RB 9KHz for QP
Start ~Stop Frequency	30MHz~1000MHz/RB 120KHz for QP

TEST SET-UP

The Same as described in section 6.2

DongGuan Precise Testing Service Co.,Ltd.



TEST RESULT OF RADIATED EMISSION TEST (9KHz ~30MHz)

EUT:	8 inch Tablet	Model Name. :	UBT081X
Temperature:	20 °C	Relative Humidity:	48%
Pressure:	1010 hPa	Test Voltage :	DC 3.7V
Test Mode :	TX	Polarization :	--

Freq.	Reading	Limit	Margin	State
(MHz)	(dBuV/m)	(dBuV/m)	(dB)	P/F
--	--	--	--	PASS
--	--	--	--	PASS

NOTE:

The amplitude of spurious emissions which are attenuated by more than 20dB below the permissible value has no need to be reported.

Distance extrapolation factor = 20 log (specific distance/test distance)(dB);

Limit line = specific limits(dBuv) + distance extrapolation factor.

DongGuan Precise Testing Service Co.,Ltd.

F616A Room, 6th Floor, Meixin Business Center, Dongcheng Middle Road, Dongguan, Guangdong, China
Tel: 86-769-23368601 Fax: 86-769-23368602 [http:// www.pts-testing.com](http://www.pts-testing.com)



TEST RESULT OF RADIATED EMISSION TEST (30MHZ-1GHZ)

EUT:	8 inch Tablet	Model Name :	UBT081X
Temperature:	20 °C	Relative Humidity:	48%
Pressure:	1010 hPa	Test Voltage :	DC3.7V
Test Mode :	TX	Polarization :	Horizontal

Frequency (MHz)	Meter Reading (dBμV)	Factor (dB)	Emission Level (dBμV/m)	Limits (dBμV/m)	Margin (dB)	Detector Type
191.0738	27.72	8.73	36.45	43.5	-7.05	Quasi-Peak
249.425	25.53	12.96	38.49	46	-7.51	Quasi-Peak
297.2241	24.15	14.45	38.6	46	-7.4	Quasi-Peak
752.7432	14.92	24.3	39.22	46	-6.78	Quasi-Peak

Remark:
Factor = Antenna Factor + Cable Loss – Pre-amplifier.

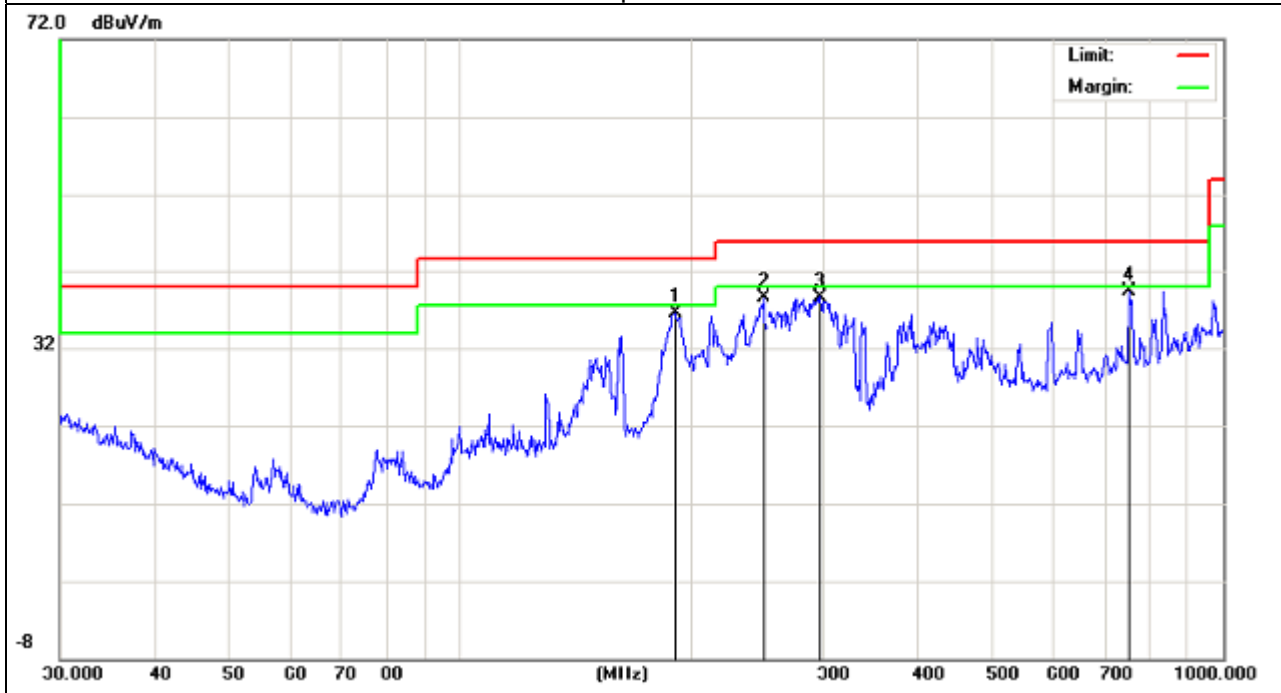

DongGuan Precise Testing Service Co.,Ltd.

F616A Room, 6th Floor, Meixin Business Center, Dongcheng Middle Road, Dongguan, Guangdong, China
Tel: 86-769-23368601 Fax: 86-769-23368602 [http:// www.pts-testing.com](http://www.pts-testing.com)



EUT:	8 inch Tablet	Model Name :	UBT081X
Temperature:	20 °C	Relative Humidity:	48%
Pressure:	1010 hPa	Test Voltage :	DC3.7V
Test Mode :	TX	Polarization :	Vertical

Frequency (MHz)	Meter Reading (dBµV)	Factor (dB)	Emission Level (dBµV/m)	Limits (dBµV/m)	Margin (dB)	Detector Type
99.9000	30.21	0.75	30.96	43.50	-12.54	Quasi-Peak
123.6900	28.34	0.60	28.94	43.50	-14.56	Quasi-Peak
245.1700	25.26	1.10	26.36	46.00	-19.64	Quasi-Peak
300.2700	27.32	1.56	28.88	46.00	-17.12	Quasi-Peak

Remark:
Factor = Antenna Factor + Cable Loss – Pre-amplifier.

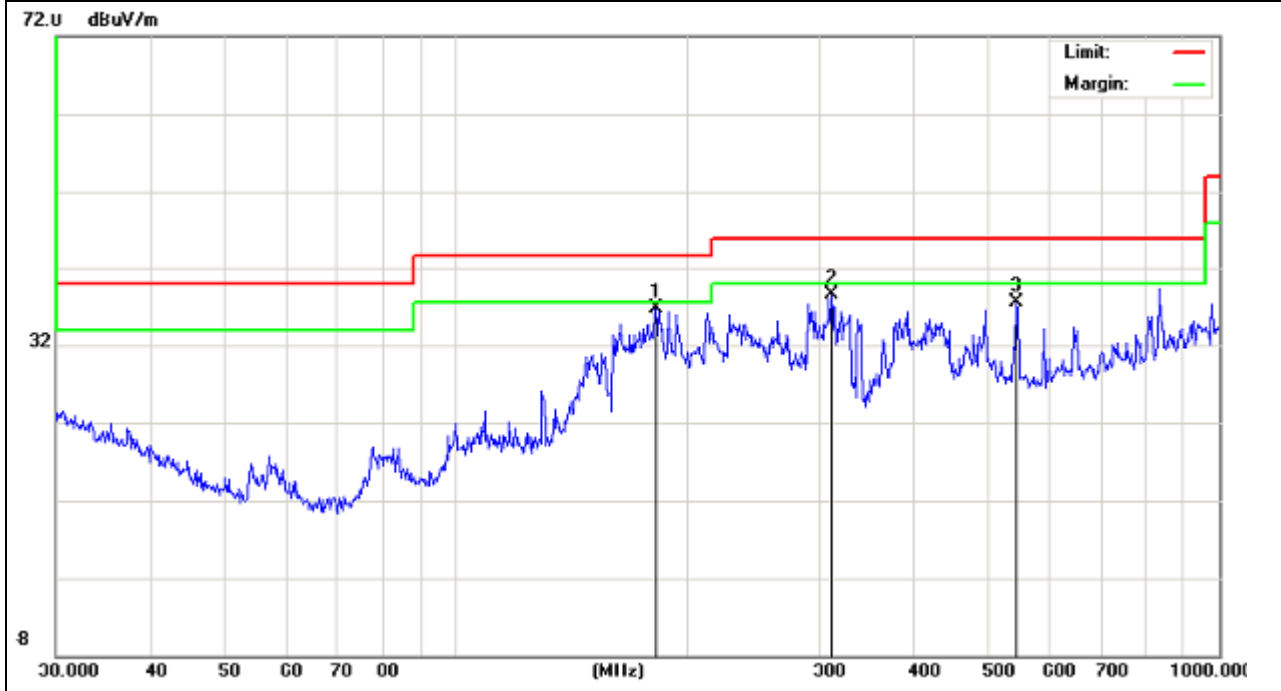

DongGuan Precise Testing Service Co.,Ltd.

F616A Room, 6th Floor, Meixin Business Center, Dongcheng Middle Road, Dongguan, Guangdong, China
Tel: 86-769-23368601 Fax: 86-769-23368602 [http:// www.pts-testing.com](http://www.pts-testing.com)



TEST RESULT OF RADIATED EMISSION TEST (1GHZ-10TH HARMONIC)

EUT:	8 inch Tablet	Model Name :	UBT081X
Temperature:	20 °C	Relative Humidity:	48%
Pressure:	1010 hPa	Test Voltage :	DC3.7V
Test Mode :	CH1 (802.11b Mode)	Polarization :	Horizontal

Frequency (MHz)	Meter Reading (dBμV)	Factor (dB)	Emission Level (dBμV/m)	Limits (dBμV/m)	Margin (dB)	Detector Type
4824	65.31	-8.12	57.19	74	-16.81	peak
4824	48.21	-8.12	40.09	54	-13.91	AVG
7239	61.02	-7.47	53.55	74	-20.45	peak
7239	48.99	-7.47	41.52	54	-12.48	AVG

Remark:
Factor = Antenna Factor + Cable Loss – Pre-amplifier.

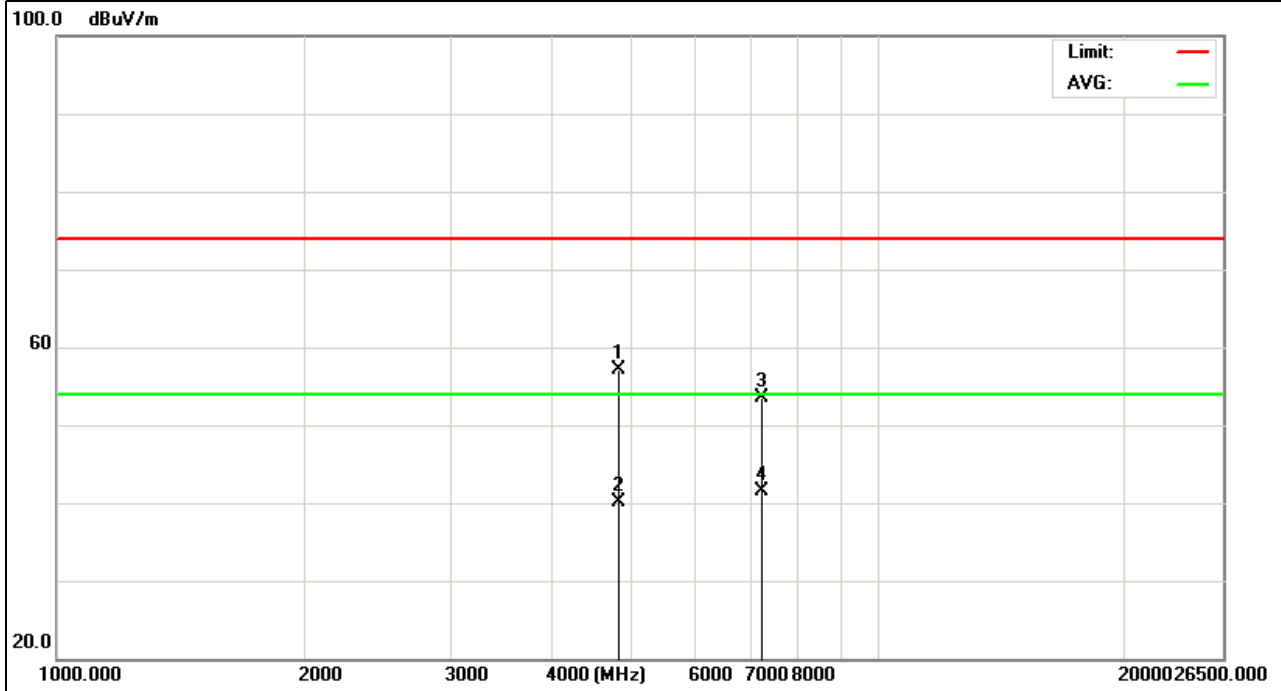

DongGuan Precise Testing Service Co.,Ltd.

F616A Room, 6th Floor, Meixin Business Center, Dongcheng Middle Road, Dongguan, Guangdong, China
Tel: 86-769-23368601 Fax: 86-769-23368602 [http:// www.pts-testing.com](http://www.pts-testing.com)



EUT:	8 inch Tablet	Model Name :	UBT081X
Temperature:	20 °C	Relative Humidity:	48%
Pressure:	1010 hPa	Test Voltage :	DC3.7V
Test Mode :	CH1 (802.11b Mode)	Polarization :	Vertical

Frequency (MHz)	Meter Reading (dBμV)	Factor (dB)	Emission Level (dBμV/m)	Limits (dBμV/m)	Margin (dB)	Detector Type
4824	65.74	-8.12	57.62	74	-16.38	peak
4824	48.89	-8.12	40.77	54	-13.23	AVG
7239	61.79	-7.47	54.32	74	-19.68	peak
7239	47.1	-7.47	39.63	54	-14.37	AVG

Remark:
Factor = Antenna Factor + Cable Loss – Pre-amplifier.

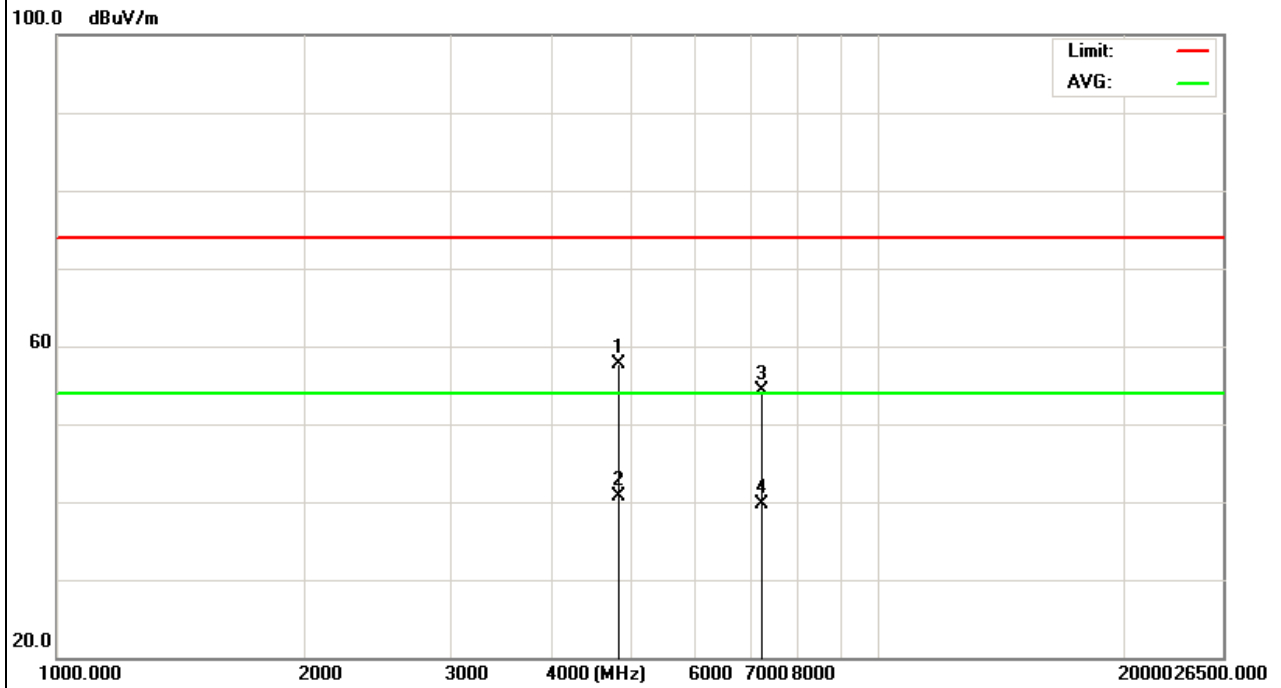

DongGuan Precise Testing Service Co.,Ltd.

F616A Room, 6th Floor, Meixin Business Center, Dongcheng Middle Road, Dongguan, Guangdong, China
Tel: 86-769-23368601 Fax: 86-769-23368602 [http:// www.pts-testing.com](http://www.pts-testing.com)



EUT:	8 inch Tablet	Model Name :	UBT081X
Temperature:	20 °C	Relative Humidity:	48%
Pressure:	1010 hPa	Test Voltage :	DC3.7V
Test Mode :	CH6 (802.11b Mode)	Polarization :	Horizontal

Frequency (MHz)	Meter Reading (dBμV)	Factor (dB)	Emission Level (dBμV/m)	Limits (dBμV/m)	Margin (dB)	Detector Type
4874	67.22	-8.19	59.03	74	-14.97	peak
4874	54.31	-8.19	46.12	54	-7.88	AVG
7311	63.44	-7.21	56.23	74	-17.77	peak
7311	52.11	-7.21	44.9	54	-9.1	AVG

Remark:
Factor = Antenna Factor + Cable Loss – Pre-amplifier.

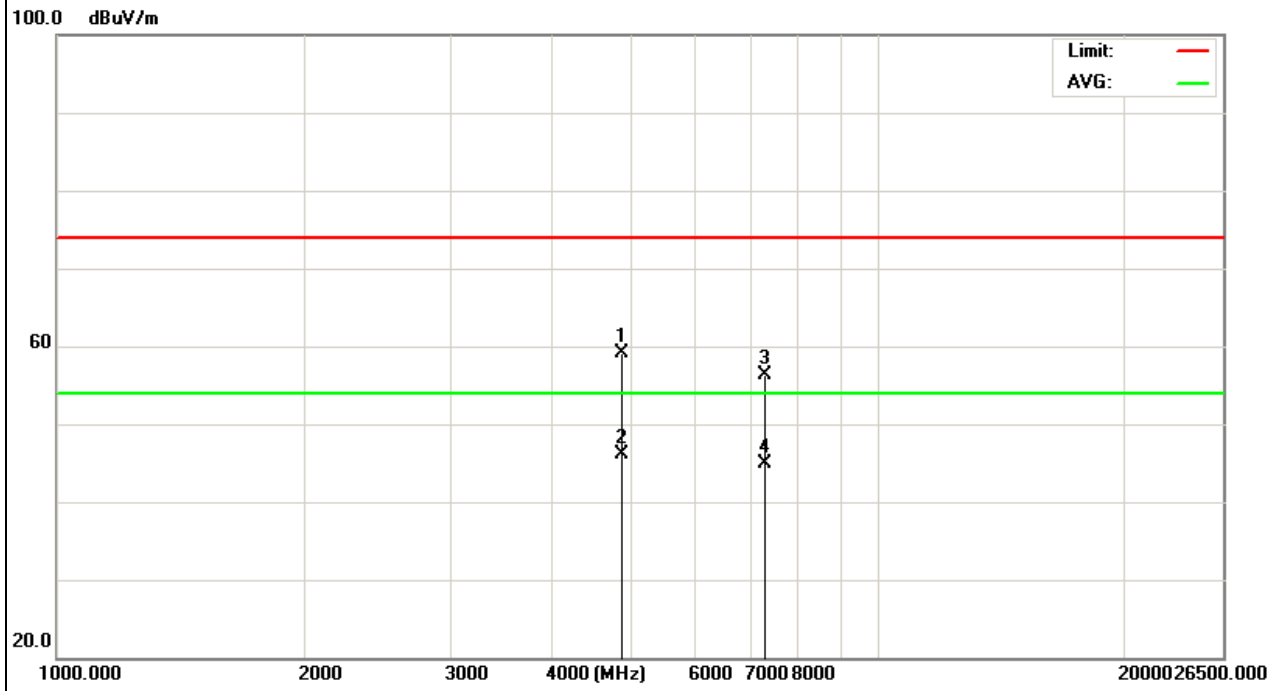

DongGuan Precise Testing Service Co.,Ltd.

F616A Room, 6th Floor, Meixin Business Center, Dongcheng Middle Road, Dongguan, Guangdong, China
Tel: 86-769-23368601 Fax: 86-769-23368602 [http:// www.pts-testing.com](http://www.pts-testing.com)



EUT:	8 inch Tablet	Model Name :	UBT081X
Temperature:	20 °C	Relative Humidity:	48%
Pressure:	1010 hPa	Test Voltage :	DC3.7V
Test Mode :	CH6 (802.11b Mode)	Polarization :	Vertical

Frequency (MHz)	Meter Reading (dBμV)	Factor (dB)	Emission Level (dBμV/m)	Limits (dBμV/m)	Margin (dB)	Detector Type
4874	66.01	-8.19	57.82	74	-16.18	peak
4874	55.51	-8.19	47.32	54	-6.68	AVG
7311	62.12	-7.21	54.91	74	-19.09	peak
7311	51.29	-7.21	44.08	54	-9.92	AVG

Remark:
Factor = Antenna Factor + Cable Loss – Pre-amplifier.

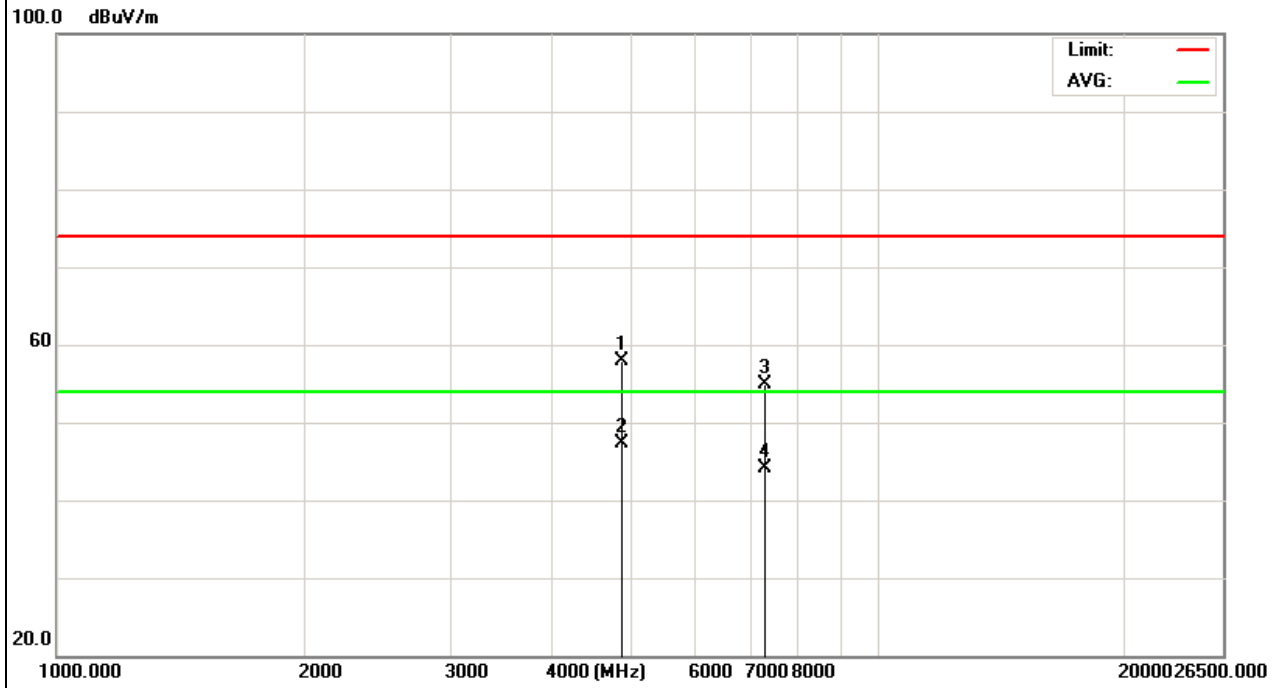

DongGuan Precise Testing Service Co.,Ltd.

F616A Room, 6th Floor, Meixin Business Center, Dongcheng Middle Road, Dongguan, Guangdong, China
Tel: 86-769-23368601 Fax: 86-769-23368602 [http:// www.pts-testing.com](http://www.pts-testing.com)



EUT:	8 inch Tablet	Model Name :	UBT081X
Temperature:	20 °C	Relative Humidity:	48%
Pressure:	1010 hPa	Test Voltage :	DC3.7V
Test Mode :	CH11 (802.11b Mode)	Polarization :	Horizontal

Frequency (MHz)	Meter Reading (dBµV)	Factor (dB)	Emission Level (dBµV/m)	Limits (dBµV/m)	Margin (dB)	Detector Type
4924	65.9	-8.22	57.68	74	-16.32	peak
4924	54.48	-8.22	46.26	54	-7.74	AVG
7386	61.39	-7.39	54	74	-20	peak
7386	52.69	-7.39	45.3	54	-8.7	AVG

Remark:
Factor = Antenna Factor + Cable Loss – Pre-amplifier.

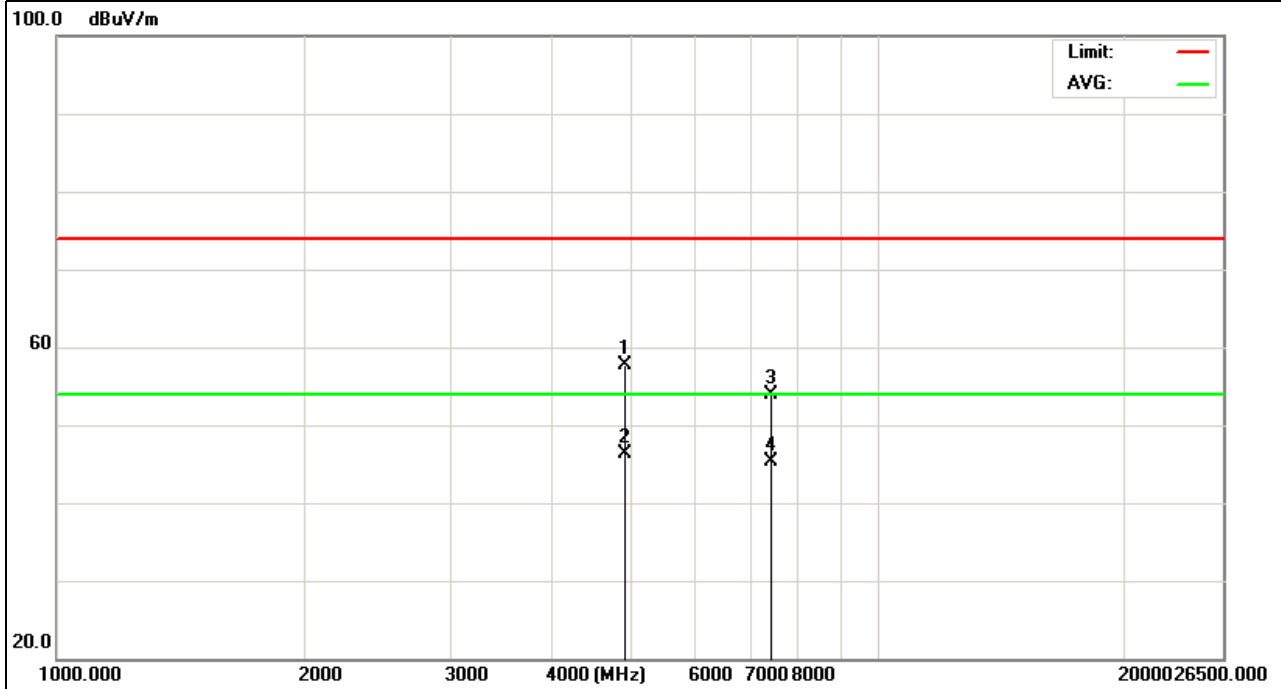

DongGuan Precise Testing Service Co.,Ltd.

F616A Room, 6th Floor, Meixin Business Center, Dongcheng Middle Road, Dongguan, Guangdong, China
Tel: 86-769-23368601 Fax: 86-769-23368602 [http:// www.pts-testing.com](http://www.pts-testing.com)



EUT:	8 inch Tablet	Model Name :	UBT081X
Temperature:	20 °C	Relative Humidity:	48%
Pressure:	1010 hPa	Test Voltage :	DC3.7V
Test Mode :	CH11 (802.11b Mode)	Polarization :	Vertical

Frequency (MHz)	Meter Reading (dBμV)	Factor (dB)	Emission Level (dBμV/m)	Limits (dBμV/m)	Margin (dB)	Detector Type
4924	64.33	-8.22	56.11	74	-17.89	peak
4924	53.31	-8.22	45.09	54	-8.91	AVG
7386	60.51	-7.39	53.12	74	-20.88	peak
7386	50.11	-7.39	42.72	54	-11.28	AVG

Remark:
Factor = Antenna Factor + Cable Loss – Pre-amplifier.

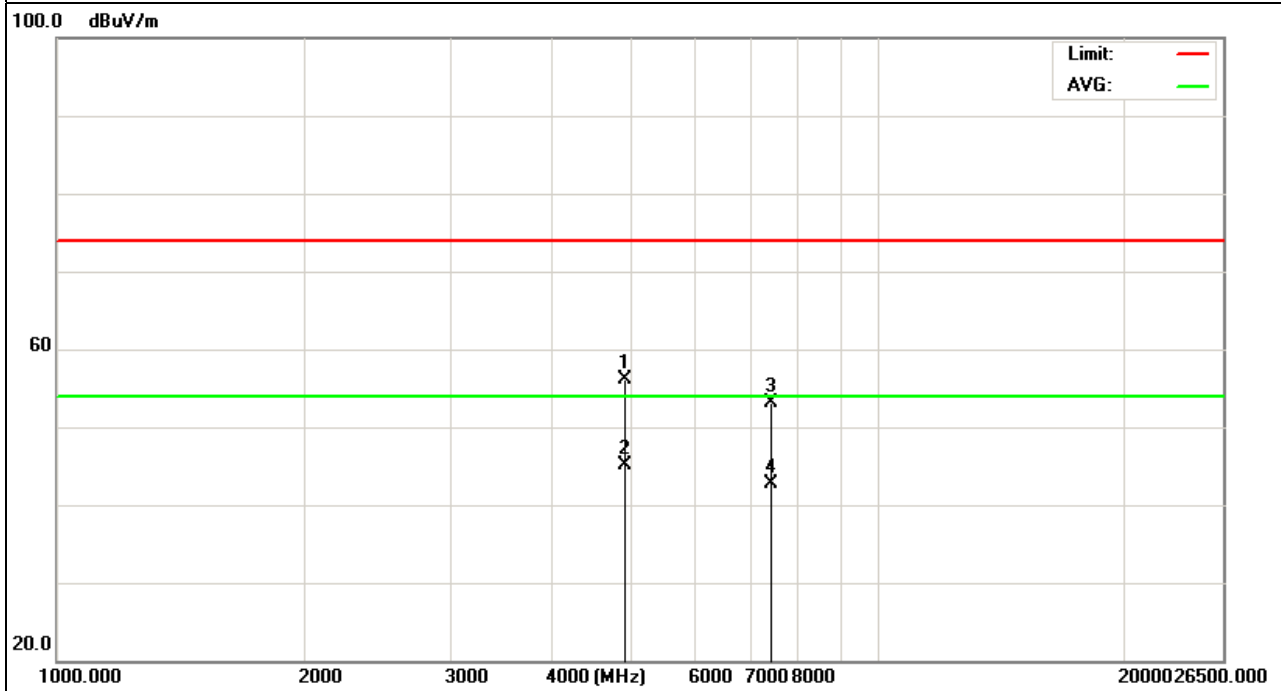

DongGuan Precise Testing Service Co.,Ltd.

F616A Room, 6th Floor, Meixin Business Center, Dongcheng Middle Road, Dongguan, Guangdong, China
Tel: 86-769-23368601 Fax: 86-769-23368602 [http:// www.pts-testing.com](http://www.pts-testing.com)



EUT:	8 inch Tablet	Model Name :	UBT081X
Temperature:	20 °C	Relative Humidity:	48%
Pressure:	1010 hPa	Test Voltage :	DC3.7V
Test Mode :	CH1 (802.11g Mode)	Polarization :	Horizontal

Frequency (MHz)	Meter Reading (dBµV)	Factor (dB)	Emission Level (dBµV/m)	Limits (dBµV/m)	Margin (dB)	Detector Type
4824	67.21	-8.12	59.09	74	-14.91	peak
4824	50.33	-8.12	42.21	54	-11.79	AVG
7239	62.12	-7.47	54.65	74	-19.35	peak
7239	48.87	-7.47	41.4	54	-12.6	AVG

Remark:
Factor = Antenna Factor + Cable Loss – Pre-amplifier.

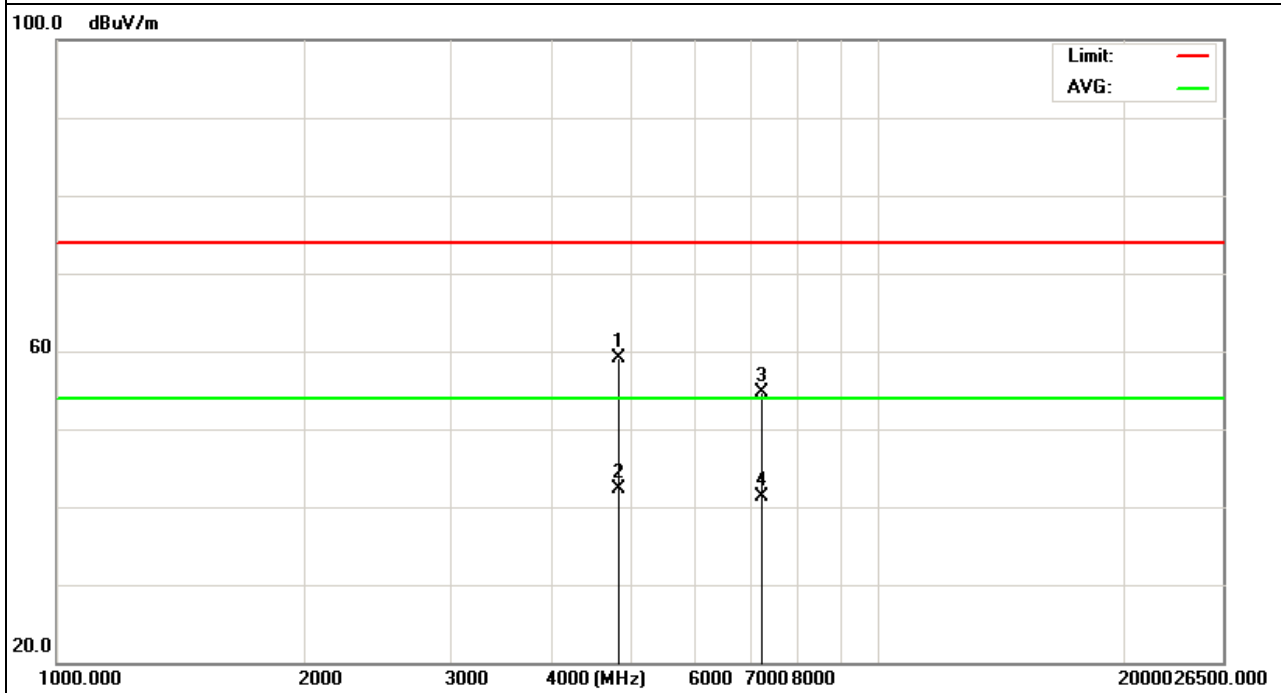

DongGuan Precise Testing Service Co.,Ltd.

F616A Room, 6th Floor, Meixin Business Center, Dongcheng Middle Road, Dongguan, Guangdong, China
 Tel: 86-769-23368601 Fax: 86-769-23368602 http:// www.pts-testing.com



EUT:	8 inch Tablet	Model Name :	UBT081X
Temperature:	20 °C	Relative Humidity:	48%
Pressure:	1010 hPa	Test Voltage :	DC3.7V
Test Mode :	CH1 (802.11g Mode)	Polarization :	Vertical

Frequency (MHz)	Meter Reading (dBµV)	Factor (dB)	Emission Level (dBµV/m)	Limits (dBµV/m)	Margin (dB)	Detector Type
4824	65.21	-8.12	57.09	74	-16.91	peak
4824	52.12	-8.12	44	54	-10	AVG
7239	63.33	-7.47	55.86	74	-18.14	peak
7239	49.8	-7.47	42.33	54	-11.67	AVG

Remark:
Factor = Antenna Factor + Cable Loss – Pre-amplifier.

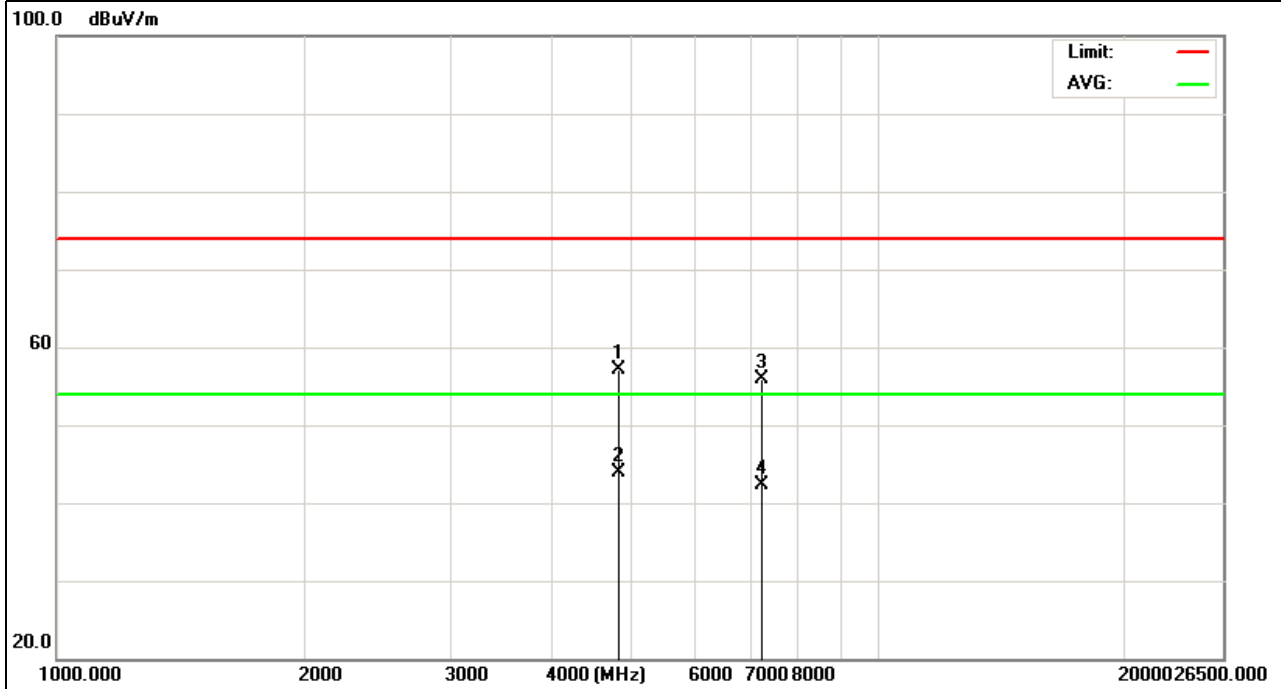

DongGuan Precise Testing Service Co.,Ltd.

F616A Room, 6th Floor, Meixin Business Center, Dongcheng Middle Road, Dongguan, Guangdong, China
 Tel: 86-769-23368601 Fax: 86-769-23368602 [http:// www.pts-testing.com](http://www.pts-testing.com)



EUT:	8 inch Tablet	Model Name :	UBT081X
Temperature:	20 °C	Relative Humidity:	48%
Pressure:	1010 hPa	Test Voltage :	DC3.7V
Test Mode :	CH6 (802.11g Mode)	Polarization :	Horizontal

Frequency (MHz)	Meter Reading (dBμV)	Factor (dB)	Emission Level (dBμV/m)	Limits (dBμV/m)	Margin (dB)	Detector Type
4874	65.32	-8.19	57.13	74	-16.87	peak
4874	53.21	-8.19	45.02	54	-8.98	AVG
7311	61.44	-7.21	54.23	74	-19.77	peak
7311	50.09	-7.21	42.88	54	-11.12	AVG

Remark:
Factor = Antenna Factor + Cable Loss – Pre-amplifier.

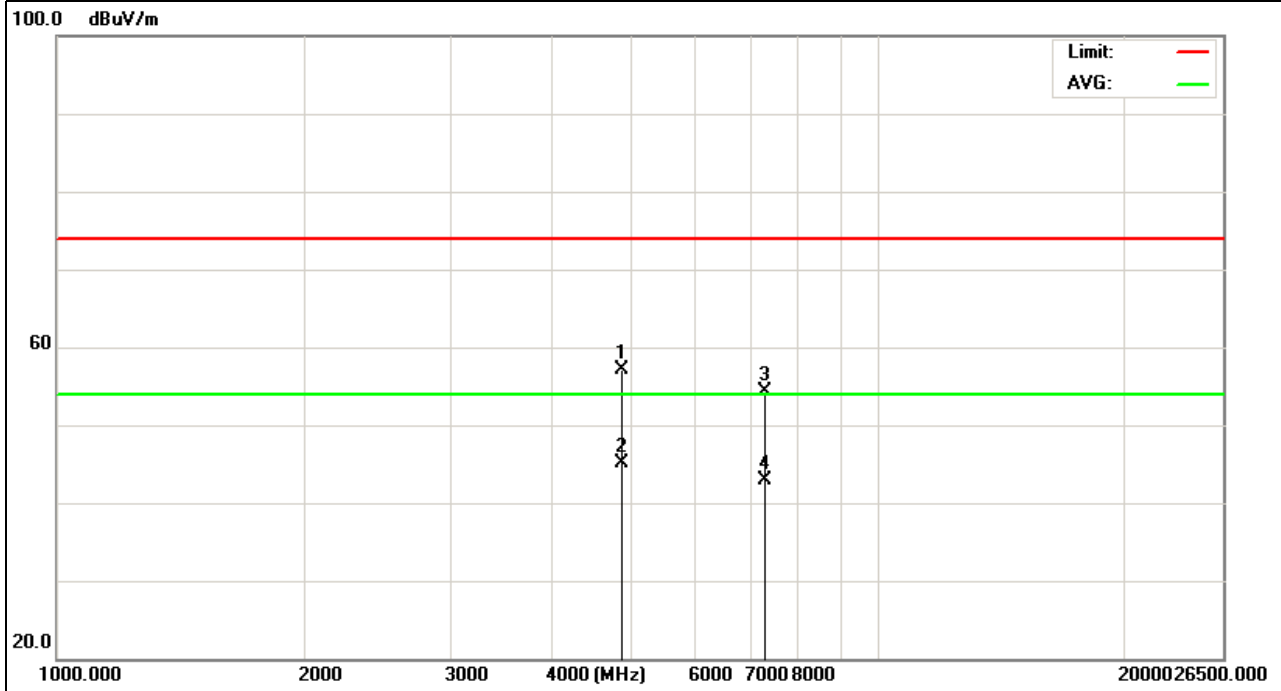

DongGuan Precise Testing Service Co.,Ltd.

F616A Room, 6th Floor, Meixin Business Center, Dongcheng Middle Road, Dongguan, Guangdong, China
Tel: 86-769-23368601 Fax: 86-769-23368602 [http:// www.pts-testing.com](http://www.pts-testing.com)



EUT:	8 inch Tablet	Model Name :	UBT081X
Temperature:	20 °C	Relative Humidity:	48%
Pressure:	1010 hPa	Test Voltage :	DC3.7V
Test Mode :	CH6 (802.11g Mode)	Polarization :	Vertical

Frequency (MHz)	Meter Reading (dBµV)	Factor (dB)	Emission Level (dBµV/m)	Limits (dBµV/m)	Margin (dB)	Detector Type
4874	66.22	-8.19	58.03	74	-15.97	peak
4874	55.14	-8.19	46.95	54	-7.05	AVG
7311	62.56	-7.21	55.35	74	-18.65	peak
7311	51.89	-7.21	44.68	54	-9.32	AVG

Remark:
Factor = Antenna Factor + Cable Loss – Pre-amplifier.

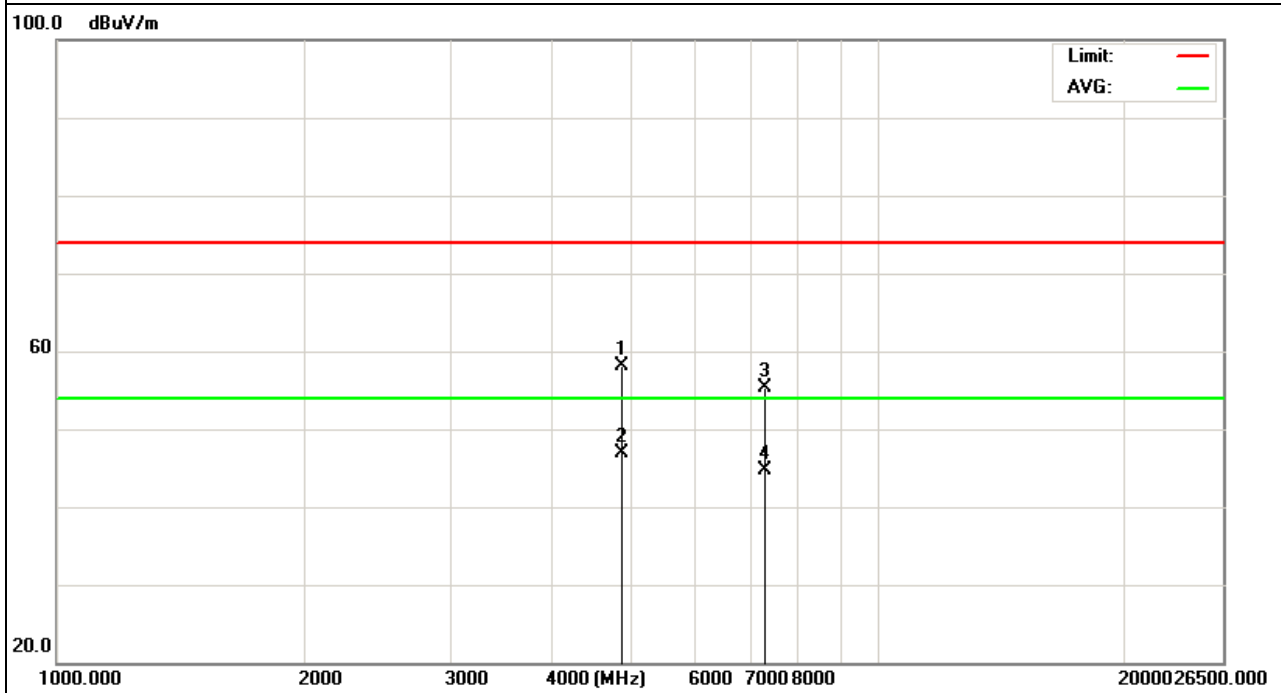

DongGuan Precise Testing Service Co.,Ltd.

F616A Room, 6th Floor, Meixin Business Center, Dongcheng Middle Road, Dongguan, Guangdong, China
Tel: 86-769-23368601 Fax: 86-769-23368602 [http:// www.pts-testing.com](http://www.pts-testing.com)



EUT:	8 inch Tablet	Model Name :	UBT081X
Temperature:	20 °C	Relative Humidity:	48%
Pressure:	1010 hPa	Test Voltage :	DC3.7V
Test Mode :	CH11 (802.11g Mode)	Polarization :	Horizontal

Frequency (MHz)	Meter Reading (dBµV)	Factor (dB)	Emission Level (dBµV/m)	Limits (dBµV/m)	Margin (dB)	Detector Type
4924	65.46	-8.22	57.24	74	-16.76	peak
4924	54.01	-8.22	45.79	54	-8.21	AVG
7386	61.11	-7.39	53.72	74	-20.28	peak
7386	51.65	-7.39	44.26	54	-9.74	AVG

Remark:
Factor = Antenna Factor + Cable Loss – Pre-amplifier.

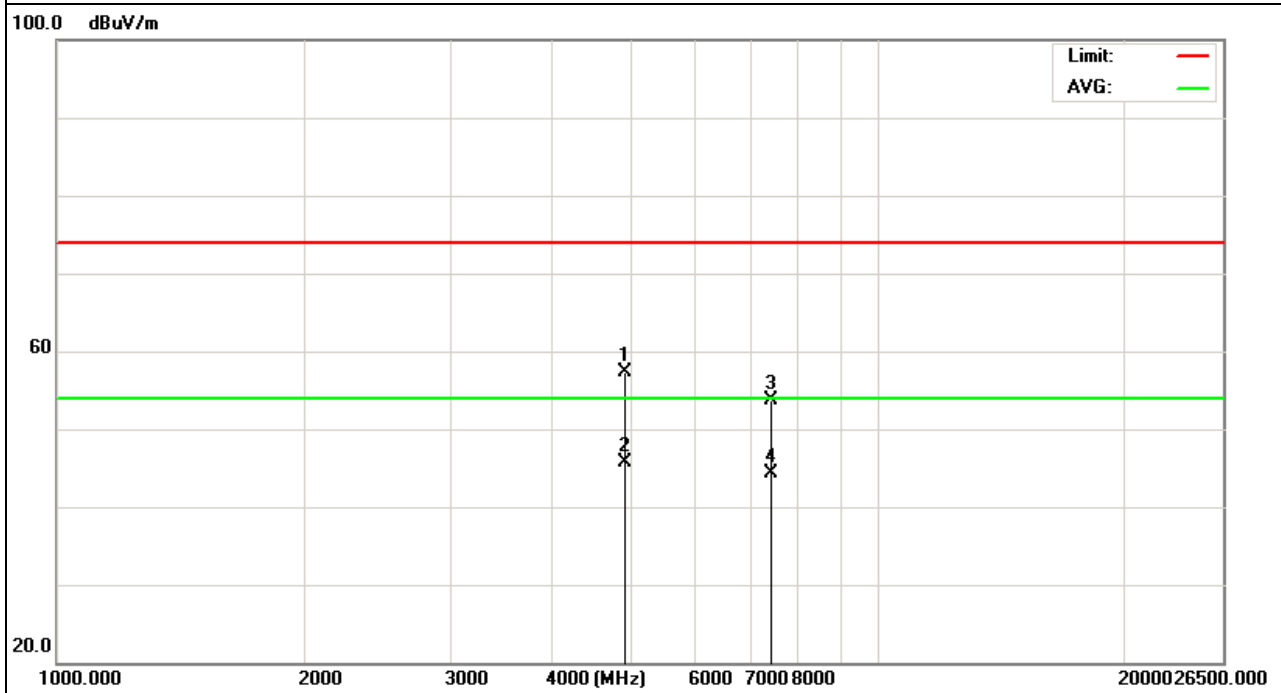

DongGuan Precise Testing Service Co.,Ltd.

F616A Room, 6th Floor, Meixin Business Center, Dongcheng Middle Road, Dongguan, Guangdong, China
Tel: 86-769-23368601 Fax: 86-769-23368602 [http:// www.pts-testing.com](http://www.pts-testing.com)



EUT:	8 inch Tablet	Model Name :	UBT081X
Temperature:	20 °C	Relative Humidity:	48%
Pressure:	1010 hPa	Test Voltage :	DC3.7V
Test Mode :	CH11(802.11g Mode)	Polarization :	Vertical

Frequency (MHz)	Meter Reading (dBμV)	Factor (dB)	Emission Level (dBμV/m)	Limits (dBμV/m)	Margin (dB)	Detector Type
4924	65.21	-8.22	56.99	74	-17.01	peak
4924	54.11	-8.22	45.89	54	-8.11	AVG
7386	61.89	-7.39	54.5	74	-19.5	peak
7386	50.09	-7.39	42.7	54	-11.3	AVG

Remark:
Factor = Antenna Factor + Cable Loss – Pre-amplifier.

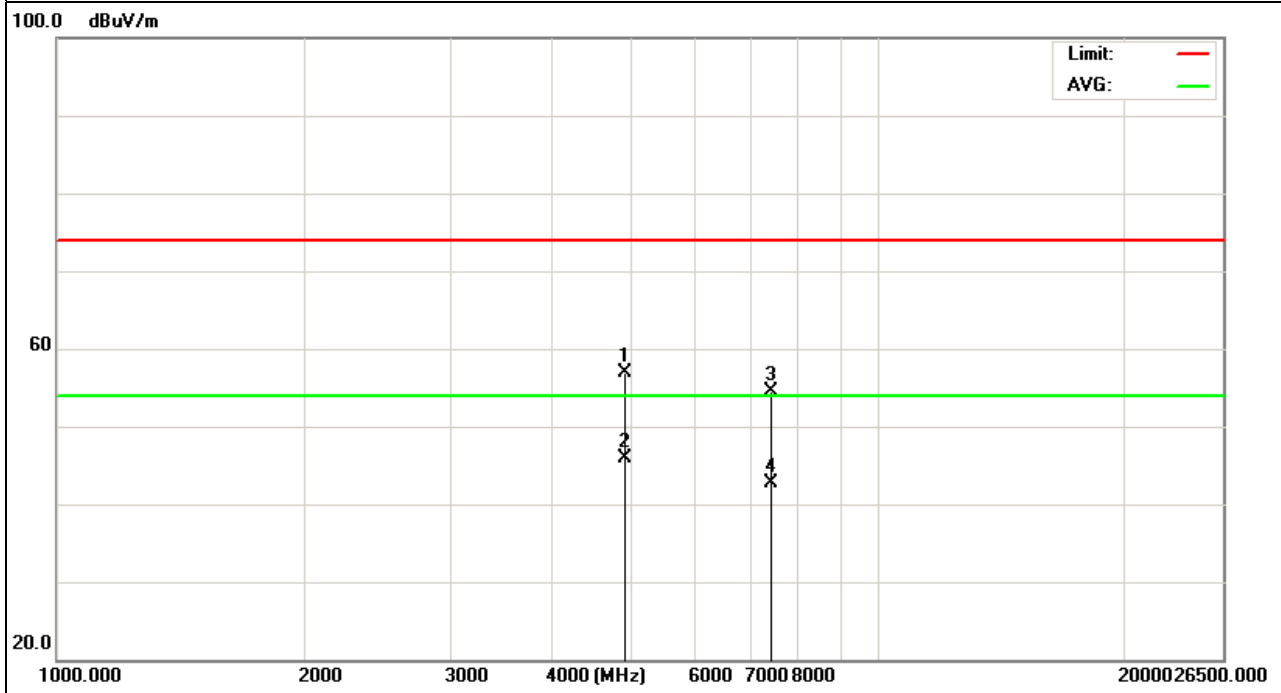

DongGuan Precise Testing Service Co.,Ltd.

F616A Room, 6th Floor, Meixin Business Center, Dongcheng Middle Road, Dongguan, Guangdong, China
Tel: 86-769-23368601 Fax: 86-769-23368602 [http:// www.pts-testing.com](http://www.pts-testing.com)



TEST RESULT (Restricted Bands Requirements)

EUT:	8 inch Tablet	Model Name :	UBT081X
Temperature:	20 °C	Relative Humidity:	48%
Pressure:	1010 hPa	Test Voltage :	DC3.7V
Test Mode :	CH1 (802.11b Mode)	Polarization :	Horizontal

Frequency (MHz)	Meter Reading (dBμV)	Factor (dB)	Emission Level (dBμV/m)	Limits (dBμV/m)	Margin (dB)	Detector Type
2397.18	70.84	-17.48	53.36	74	-20.64	peak
2400	67.77	-17.46	50.31	74	-23.69	peak
2400	61.97	-17.46	44.51	54	-9.49	AVG

Remark:
Factor = Antenna Factor + Cable Loss – Pre-amplifier.

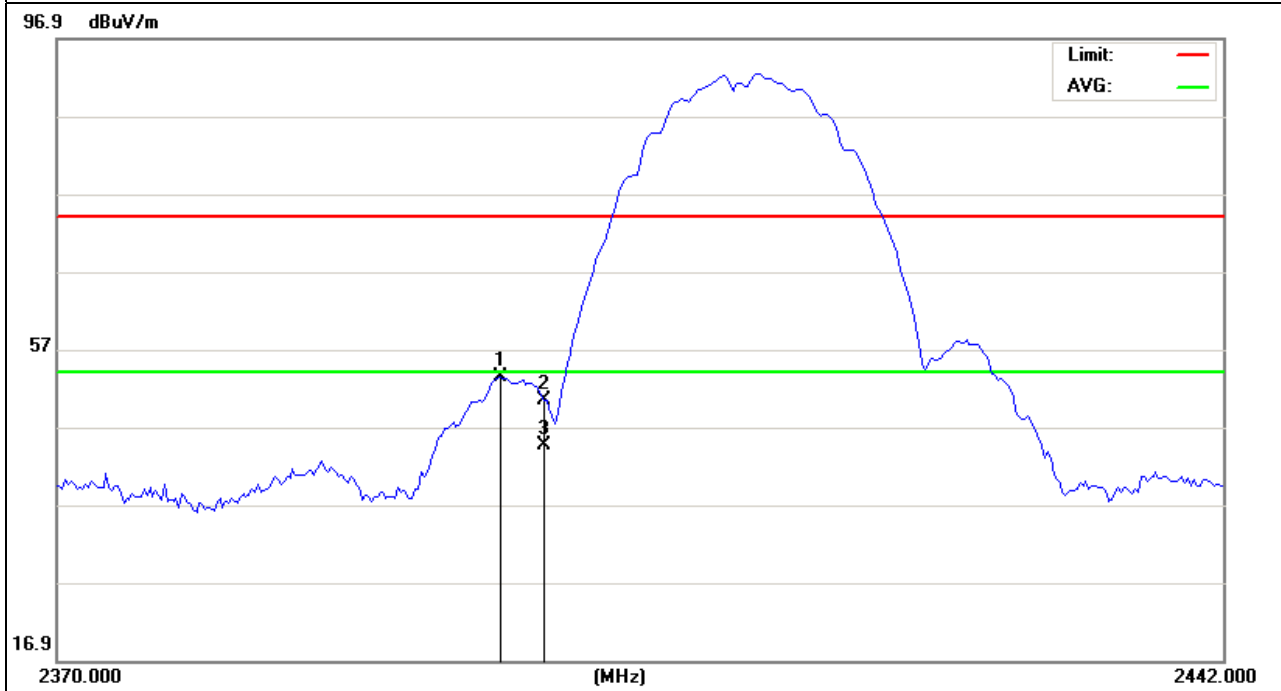

DongGuan Precise Testing Service Co.,Ltd.

F616A Room, 6th Floor, Meixin Business Center, Dongcheng Middle Road, Dongguan, Guangdong, China
Tel: 86-769-23368601 Fax: 86-769-23368602 [http:// www.pts-testing.com](http://www.pts-testing.com)



EUT:	8 inch Tablet	Model Name :	UBT081X
Temperature:	20 °C	Relative Humidity:	48%
Pressure:	1010 hPa	Test Voltage :	DC3.7V
Test Mode :	CH1 (802.11b Mode)	Polarization :	Vertical

Frequency (MHz)	Meter Reading (dBμV)	Factor (dB)	Emission Level (dBμV/m)	Limits (dBμV/m)	Margin (dB)	Detector Type
2397.36	73.45	-17.48	55.97	74	-18.03	peak
2397.36	60.14	-17.48	42.66	54	-11.34	AVG
2400	69.15	-17.46	51.69	74	-22.31	peak
2400	59.22	-17.46	41.76	54	-12.24	AVG

Remark:
Factor = Antenna Factor + Cable Loss – Pre-amplifier.

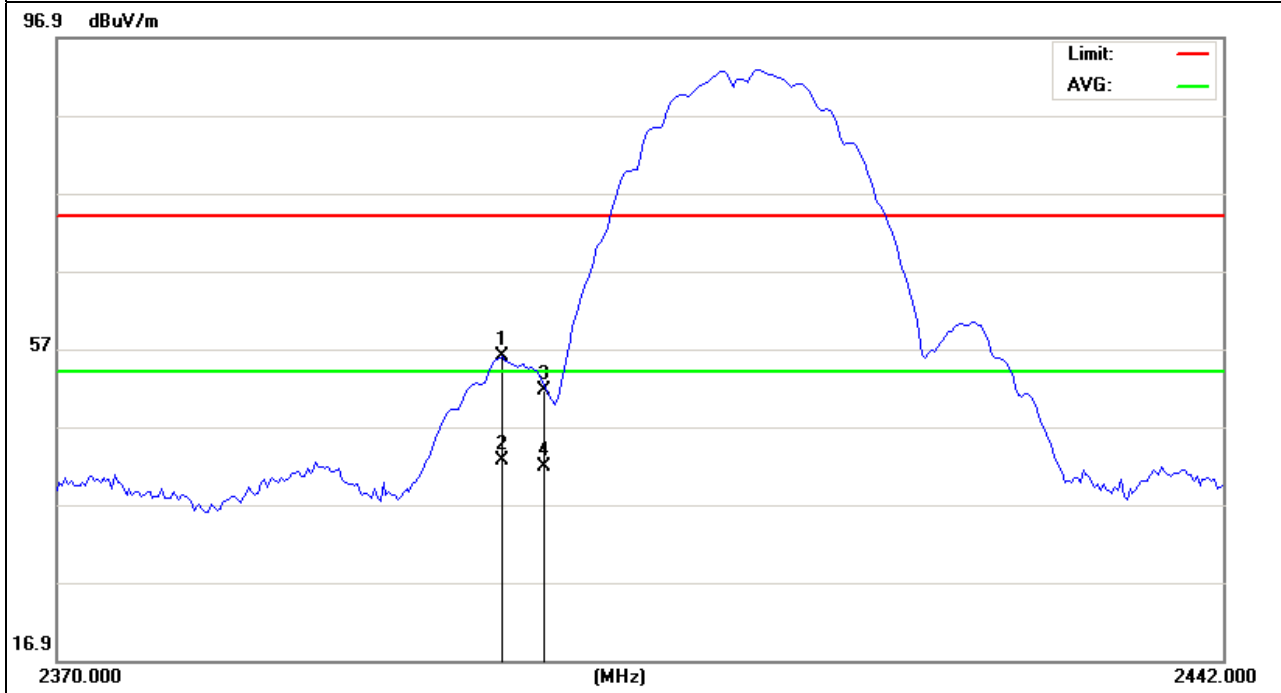

DongGuan Precise Testing Service Co.,Ltd.

F616A Room, 6th Floor, Meixin Business Center, Dongcheng Middle Road, Dongguan, Guangdong, China
 Tel: 86-769-23368601 Fax: 86-769-23368602 [http:// www.pts-testing.com](http://www.pts-testing.com)



EUT:	8 inch Tablet	Model Name :	UBT081X
Temperature:	20 °C	Relative Humidity:	48%
Pressure:	1010 hPa	Test Voltage :	DC3.7V
Test Mode :	CH11 (802.11b Mode)	Polarization :	Horizontal

Frequency (MHz)	Meter Reading (dBμV)	Factor (dB)	Emission Level (dBμV/m)	Limits (dBμV/m)	Margin (dB)	Detector Type
2483.5	59.91	-17.35	42.56	74	-31.44	peak
2483.5	51.09	-17.35	33.74	54	-20.26	AVG

Remark:
Factor = Antenna Factor + Cable Loss – Pre-amplifier.

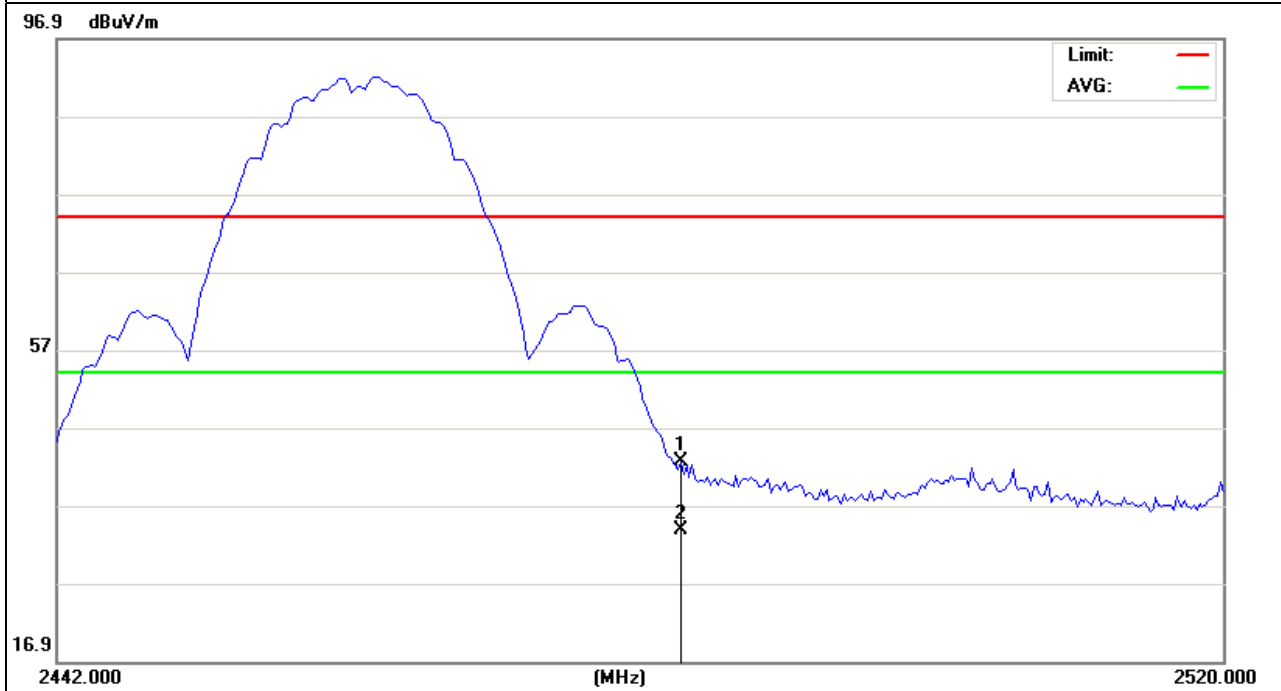

DongGuan Precise Testing Service Co.,Ltd.

F616A Room, 6th Floor, Meixin Business Center, Dongcheng Middle Road, Dongguan, Guangdong, China
 Tel: 86-769-23368601 Fax: 86-769-23368602 [http:// www.pts-testing.com](http://www.pts-testing.com)



EUT:	8 inch Tablet	Model Name :	UBT081X
Temperature:	20 °C	Relative Humidity:	48%
Pressure:	1010 hPa	Test Voltage :	DC3.7V
Test Mode :	CH11 (802.11b Mode)	Polarization :	Vertical

Frequency (MHz)	Meter Reading (dBμV)	Factor (dB)	Emission Level (dBμV/m)	Limits (dBμV/m)	Margin (dB)	Detector Type
2483.5	58.19	-17.35	40.84	74	-33.16	peak
2483.5	50.17	-17.35	32.82	54	-21.18	AVG

Remark:
Factor = Antenna Factor + Cable Loss – Pre-amplifier.

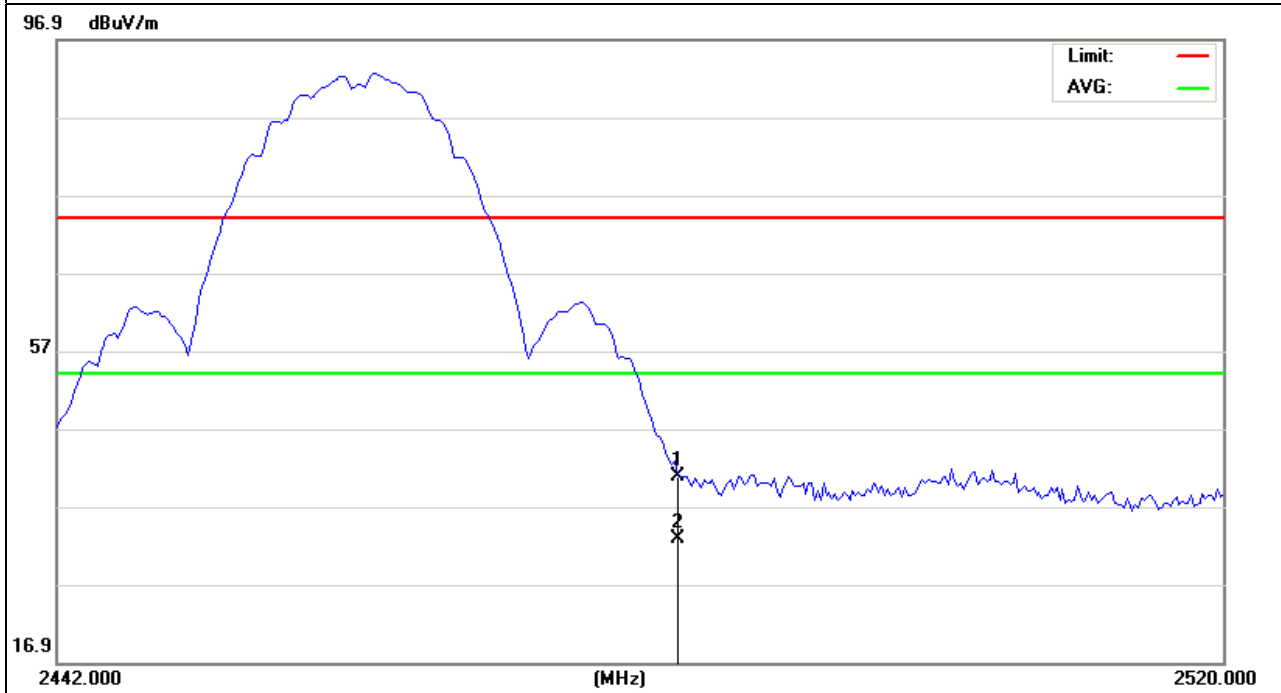

DongGuan Precise Testing Service Co.,Ltd.

F616A Room, 6th Floor, Meixin Business Center, Dongcheng Middle Road, Dongguan, Guangdong, China
 Tel: 86-769-23368601 Fax: 86-769-23368602 [http:// www.pts-testing.com](http://www.pts-testing.com)



EUT:	8 inch Tablet	Model Name :	UBT081X
Temperature:	20 °C	Relative Humidity:	48%
Pressure:	1010 hPa	Test Voltage :	DC3.7V
Test Mode :	CH1 (802.11g Mode)	Polarization :	Horizontal

Frequency (MHz)	Meter Reading (dBμV)	Factor (dB)	Emission Level (dBμV/m)	Limits (dBμV/m)	Margin (dB)	Detector Type
2400	85.86	-17.46	68.4	74	-5.6	peak
2400	64.97	-17.46	47.51	54	-6.49	AVG

Remark:
Factor = Antenna Factor + Cable Loss – Pre-amplifier.

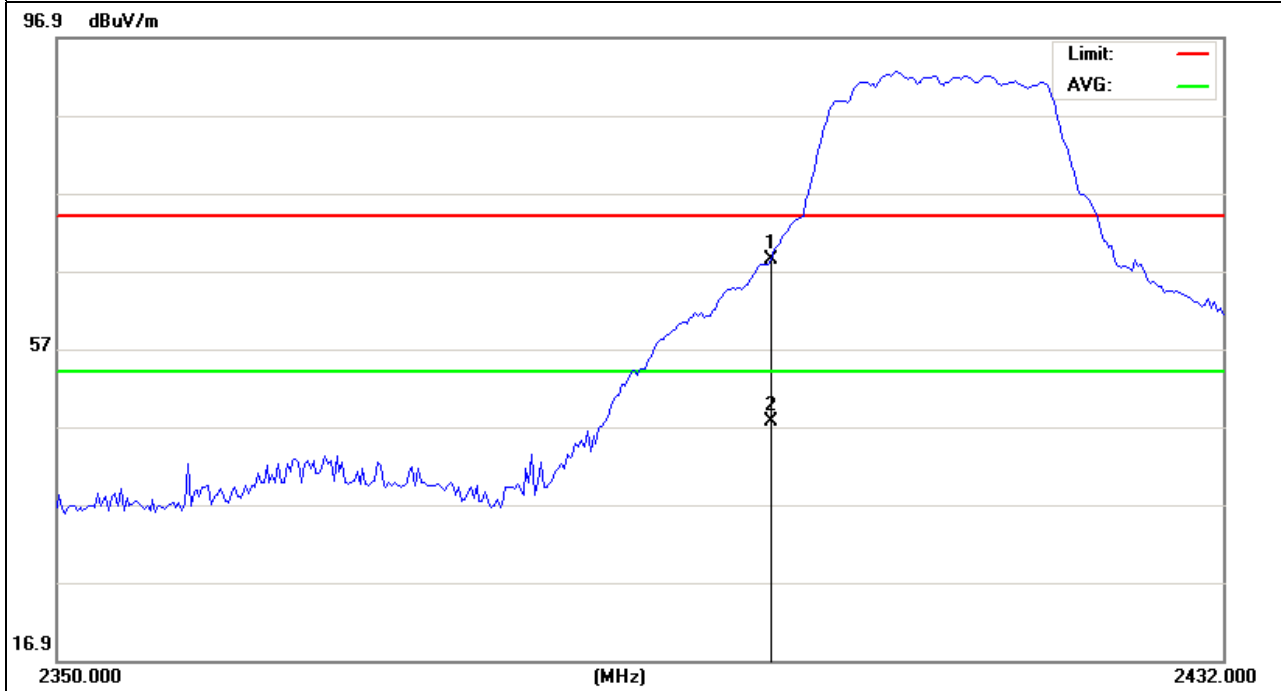

DongGuan Precise Testing Service Co.,Ltd.

F616A Room, 6th Floor, Meixin Business Center, Dongcheng Middle Road, Dongguan, Guangdong, China
 Tel: 86-769-23368601 Fax: 86-769-23368602 [http:// www.pts-testing.com](http://www.pts-testing.com)



EUT:	8 inch Tablet	Model Name :	UBT081X
Temperature:	20 °C	Relative Humidity:	48%
Pressure:	1010 hPa	Test Voltage :	DC3.7V
Test Mode :	CH1 (802.11g Mode)	Polarization :	Vertical

Frequency (MHz)	Meter Reading (dBμV)	Factor (dB)	Emission Level (dBμV/m)	Limits (dBμV/m)	Margin (dB)	Detector Type
2400	85.66	-17.46	68.2	74	-5.8	peak
2400	64.34	-17.46	46.88	54	-7.12	AVG

Remark:
Factor = Antenna Factor + Cable Loss – Pre-amplifier.

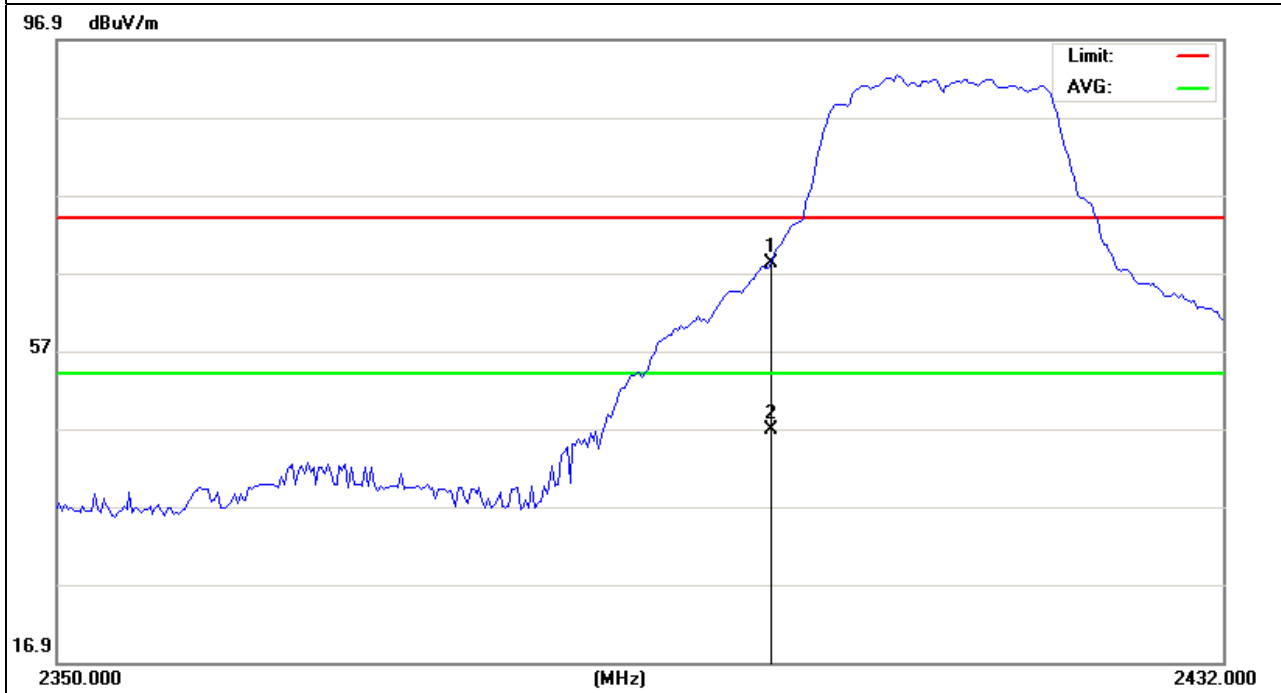

DongGuan Precise Testing Service Co.,Ltd.

F616A Room, 6th Floor, Meixin Business Center, Dongcheng Middle Road, Dongguan, Guangdong, China
 Tel: 86-769-23368601 Fax: 86-769-23368602 [http:// www.pts-testing.com](http://www.pts-testing.com)



EUT:	8 inch Tablet	Model Name :	UBT081X
Temperature:	20 °C	Relative Humidity:	48%
Pressure:	1010 hPa	Test Voltage :	DC3.7V
Test Mode :	CH11 (802.11b Mode)	Polarization :	Horizontal

Frequency (MHz)	Meter Reading (dBμV)	Factor (dB)	Emission Level (dBμV/m)	Limits (dBμV/m)	Margin (dB)	Detector Type
2483.5	79.26	-17.35	61.91	74	-12.09	peak
2483.5	64.12	-17.35	46.77	54	-7.23	AVG

Remark:
Factor = Antenna Factor + Cable Loss – Pre-amplifier.

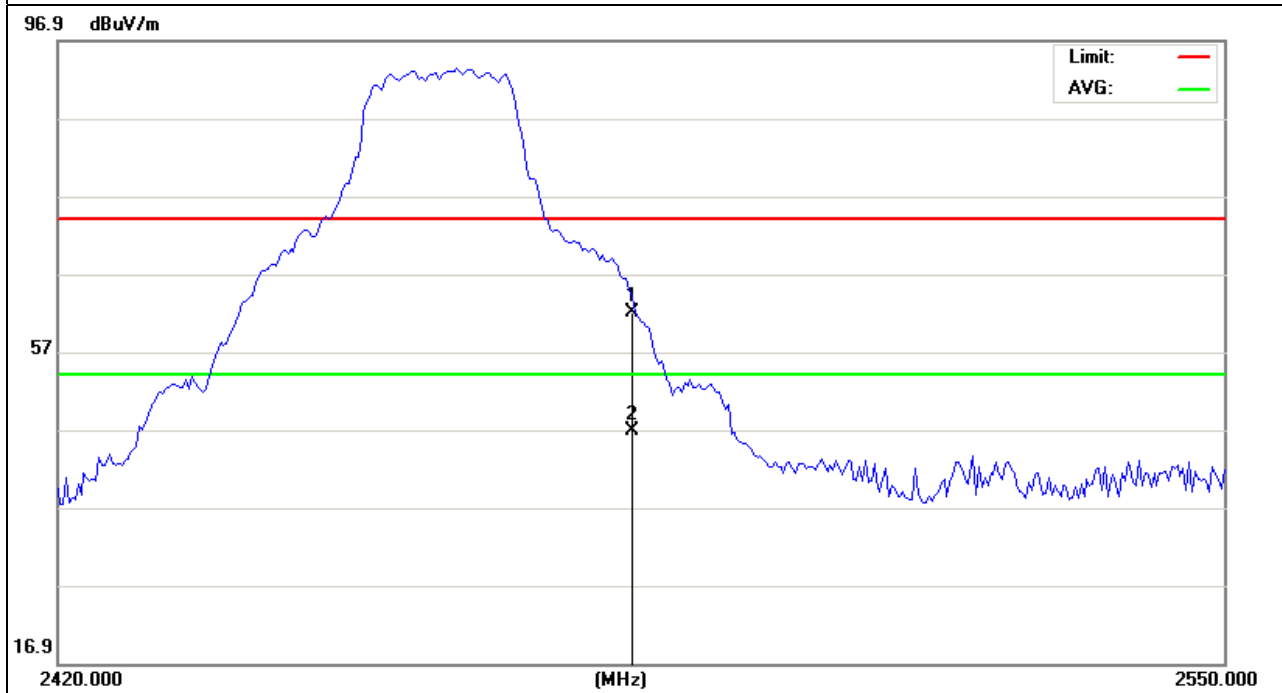

DongGuan Precise Testing Service Co.,Ltd.

F616A Room, 6th Floor, Meixin Business Center, Dongcheng Middle Road, Dongguan, Guangdong, China
 Tel: 86-769-23368601 Fax: 86-769-23368602 [http:// www.pts-testing.com](http://www.pts-testing.com)



EUT:	8 inch Tablet	Model Name :	UBT081X
Temperature:	20 °C	Relative Humidity:	48%
Pressure:	1010 hPa	Test Voltage :	DC3.7V
Test Mode :	CH11 (802.11g Mode)	Polarization :	Vertical

Frequency (MHz)	Meter Reading (dBµV)	Factor (dB)	Emission Level (dBµV/m)	Limits (dBµV/m)	Margin (dB)	Detector Type
2483.5	80.18	-17.35	62.83	74	-11.17	peak
2483.5	65.15	-17.35	47.8	54	-6.2	AVG

Remark:
Factor = Antenna Factor + Cable Loss – Pre-amplifier.

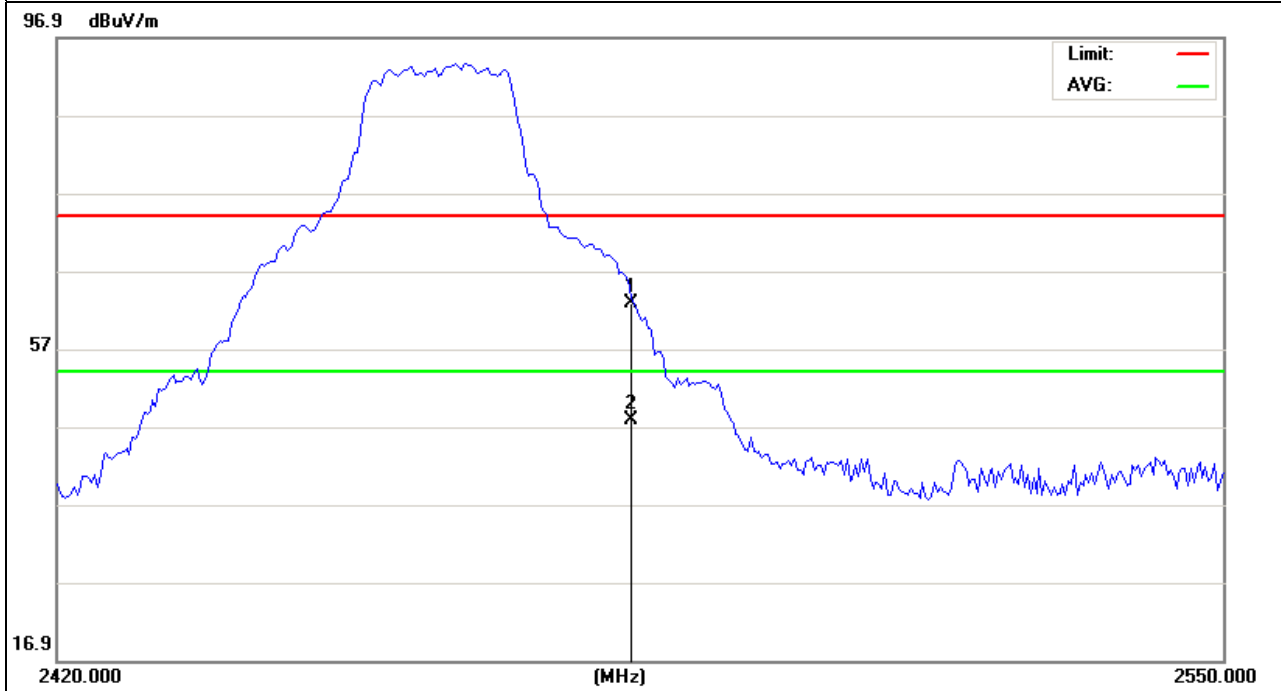

DongGuan Precise Testing Service Co.,Ltd.

F616A Room, 6th Floor, Meixin Business Center, Dongcheng Middle Road, Dongguan, Guangdong, China
Tel: 86-769-23368601 Fax: 86-769-23368602 [http:// www.pts-testing.com](http://www.pts-testing.com)



10. ANTENNA REQUIREMENT

STANDARD REQUIREMENT

15.203 requirement: For intentional device, according to 15.203: an intentional radiator shall be designed to ensure that no antenna other than that furnished by the responsible party shall be used with the device.

EUT ANTENNA

The EUT antenna is an Integrated Antenna. It comply with the standard requirement.



PPENDIX 1
PHOTOGRAPHS OF THE TEST SETUP

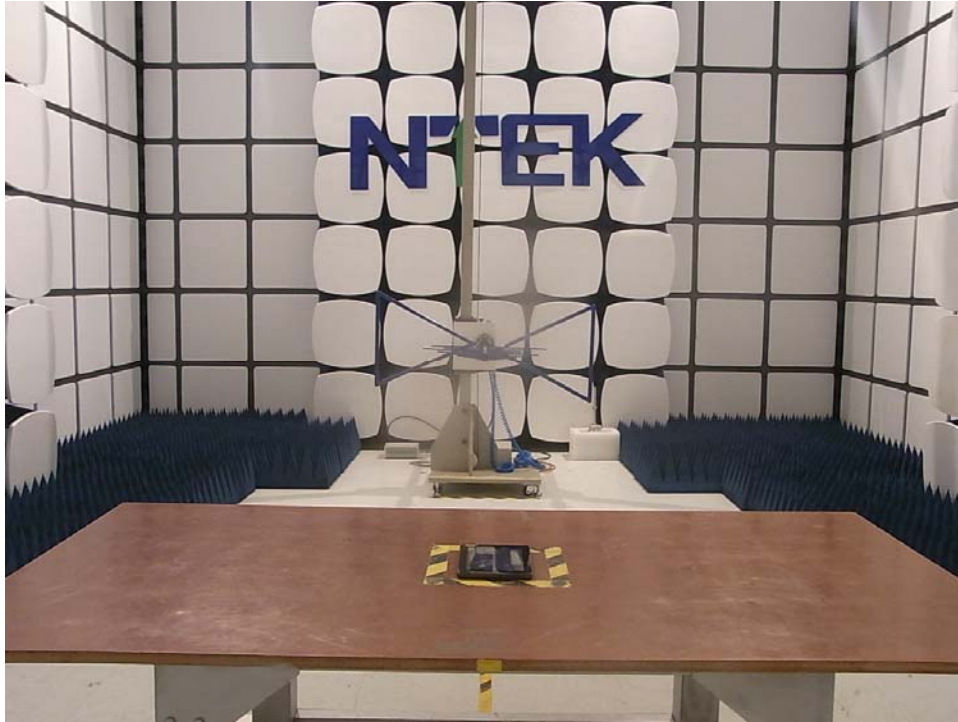

DongGuan Precise Testing Service Co.,Ltd.

F616A Room, 6th Floor, Meixin Business Center, Dongcheng Middle Road, Dongguan, Guangdong, China
Tel: 86-769-23368601 Fax: 86-769-23368602 [http:// www.pts-testing.com](http://www.pts-testing.com)



PHOTOGRAPHS OF THE TEST SETUP (>1GHZ)

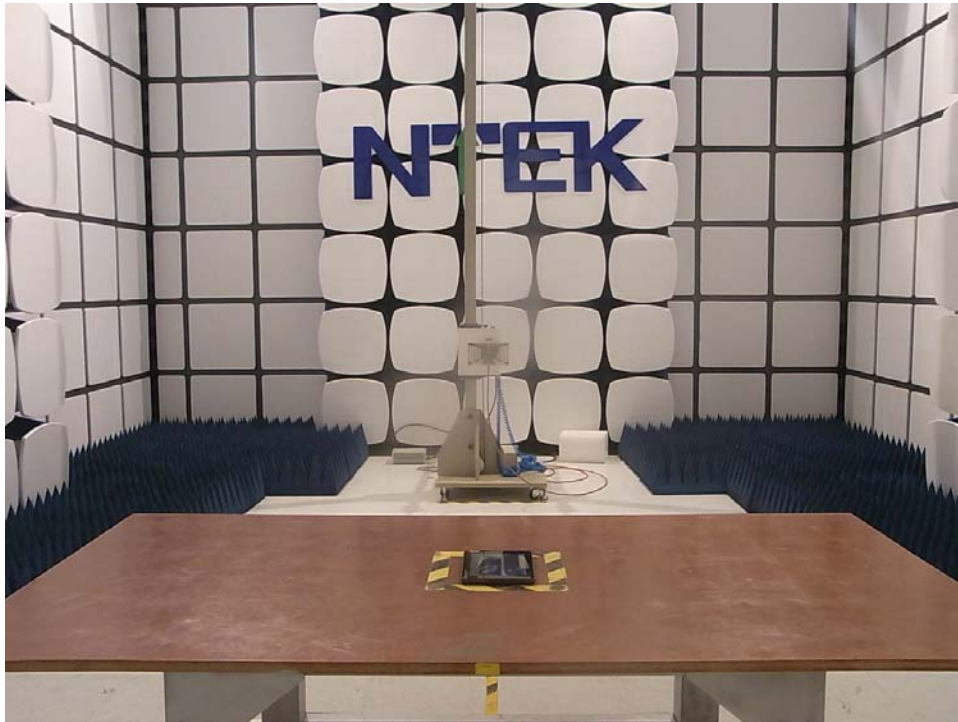

DongGuan Precise Testing Service Co.,Ltd.

F616A Room, 6th Floor, Meixin Business Center, Dongcheng Middle Road, Dongguan, Guangdong, China
Tel: 86-769-23368601 Fax: 86-769-23368602 [http:// www.pts-testing.com](http://www.pts-testing.com)



--- END OF REPORT ---

DongGuan Precise Testing Service Co.,Ltd.

F616A Room, 6th Floor, Meixin Business Center, Dongcheng Middle Road, Dongguan, Guangdong, China
Tel: 86-769-23368601 Fax: 86-769-23368602 [http:// www.pts-testing.com](http://www.pts-testing.com)