



# Electromagnetic Compatibility Test Report

Tests Performed on an RF IDEas, Inc.

Multi-Protocol RFID Reader, Model RDR-7L82AKU

Radiometrics Document RP-8570A





<i>Product Detail:</i>			
FCC ID: M9MLC7L81			
IC: 6571A-LC7L81			
Equipment type: Multi-Protocol RFID Reader			
<i>Test Standards:</i>			
US CFR Title 47, Chapter I, FCC Part 15 Subpart C			
FCC Part 15 CFR Title 47: 2016			
Innovation, Science, and Economic Development Canada RSS-210, Issue 9: 2016 as required for Category I Equipment			
This report concerns: Original Equipment			
FCC Part 15.225			
<i>Tests Performed For:</i>		<i>Test Facility:</i>	
<b>RF IDEas, Inc.</b>		<b>Radiometrics Midwest Corporation</b>	
4020 Winnetka Av.		12 East Devonwood	
Rolling Meadows, IL 60008		Romeoville, IL 60446	
<i>Test Date(s): (Month-Day-Year)</i>			
December 14, 2016 thru May 2, 2017			
Document RP-8570A Revisions:			
Rev.	Issue Date	Affected Sections	Revised By
0	May 25, 2017		
1	June 12, 2017	Cover, 10.2, 10.3.1 10.4, 10.5	Joseph Strzelecki

## Table of Contents

1 ADMINISTRATIVE DATA .....	3
2 TEST SUMMARY AND RESULTS .....	3
2.1 RF Exposure Compliance Requirements .....	3
3 EQUIPMENT UNDER TEST (EUT) DETAILS .....	4
3.1 EUT Description .....	4
3.1.1 FCC Section 15.203 & RSS-GEN Antenna Requirements .....	4
3.2 Related Submittals .....	4
4 TESTED SYSTEM DETAILS .....	4
4.1 Tested System Configuration .....	4
4.2 Special Accessories .....	4
4.3 Equipment Modifications .....	5
5 TEST SPECIFICATIONS AND RELATED DOCUMENTS .....	5
6 RADIOMETRICS' TEST FACILITIES .....	5
7 DEVIATIONS AND EXCLUSIONS FROM THE TEST SPECIFICATIONS .....	5
8 CERTIFICATION .....	6
9 TEST EQUIPMENT TABLE .....	6
10 TEST SECTIONS .....	6
10.1 AC Conducted Emissions .....	6
10.2 Radiated RF Emissions .....	12
10.2.1 Field Strength Calculation .....	13
10.2.2 Radiated Emissions Test Results .....	13
10.3 Magnetic Field Measurements and Decay Factor Calculations .....	16
10.3.1 Magnetic Field Radiated Emissions Results (0.009 to 30 MHz) .....	17
10.4 Occupied Bandwidth Data .....	17
10.5 Frequency Stability .....	19
10.5.1 Test Results for Frequency Stability .....	19
11 MEASUREMENT INSTRUMENTATION UNCERTAINTY .....	20

Notice: This report must not be reproduced (except in full) without the written approval of Radiometrics Midwest Corporation.

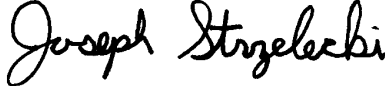
**1 ADMINISTRATIVE DATA**

<i>Equipment Under Test:</i>	
An RF IDEas, Inc., Multi-Protocol RS232 RFID Reader Model: RDR-7L82AKU This will be referred to as the EUT in this Report	
<i>Date EUT Received at Radiometrics: (Month-Day-Year)</i>	<i>Test Date(s): (Month-Day-Year)</i>
December 14, 2016	December 14, 2016 thru May 2, 2017
<i>Test Report Written By:</i>	<i>Test Witnessed By:</i>
Joseph Strzelecki Senior EMC Engineer	The tests were not witnessed by RF IDEas, Inc.
<i>Radiometrics' Personnel Responsible for Test:</i>	<i>Test Report Approved By</i>
 05/26/2017	
Joseph Strzelecki Senior EMC Engineer NARTE EMC-000877-NE	Chris W. Carlson Director of Engineering NARTE EMC-000921-NE

**2 TEST SUMMARY AND RESULTS**

The EUT (Equipment Under Test) is a Multi-Protocol RS232 RFID Reader, Model RDR-7L82AKU, manufactured by RF IDEas, Inc. The detailed test results are presented in a separate section. The following is a summary of the test results.

**Emissions Tests Results**

Environmental Phenomena	Frequency Range	Basic Standard	Test Result
RF Radiated Emissions	30-1000 MHz	RSS-210 & FCC Part 15	Pass
Conducted Emissions, AC Mains	0.15 - 30 MHz	RSS-210 & FCC Part 15	Pass
RF Radiated Emissions H-Field	0.009 – 30 MHz	RSS-210 & FCC Part 15	Pass

Note: The RSS-210 specification is not currently covered in Radiometrics' Scope of Accreditation. This is technically very similar to FCC, CFR 47 Part 15 which is on Radiometrics scope.

**2.1 RF Exposure Compliance Requirements**

Since the effective power output is less than 1 mW, the EUT meets the FCC requirement for RF exposure and is exempt from RSS-102. There are no power level adjustments and the antenna is permanently attached. The detailed calculations for RF Exposure are presented in a separate document.

### 3 EQUIPMENT UNDER TEST (EUT) DETAILS

#### 3.1 EUT Description

The EUT is a Multi-Protocol RFID reader, Model RDR-7L82AKU, manufactured by RF IDEas, Inc. The EUT was in good working condition during the tests, with no known defects.

##### 3.1.1 FCC Section 15.203 & RSS-GEN Antenna Requirements

The antenna is permanently attached to the PCB. The antenna is internal to the EUT and it is not readily available to be modified by the end user.

#### 3.2 Related Submittals

RF IDEas, Inc. is not submitting any other products simultaneously for equipment authorization related to the EUT.

### 4 TESTED SYSTEM DETAILS

#### 4.1 Tested System Configuration

The system was configured for testing in a typical fashion. The EUT was placed on an 80-cm high, nonconductive test stand. The testing was performed in conditions as close as possible to installed conditions. Wiring was consistent with manufacturer's recommendations. Power was supplied at 115 VAC, 60 Hz single-phase to the host computer. The EUT was powered from either the USB or PS/2 port.

The identification for all equipment, plus descriptions of all cables used in the tested system, are:

**Tested System Configuration List**

Item	Description	Type*	Manufacturer	Model Number	Serial Number
1	RFID Card Reader	E	RF IDEas	RDR-7L82AKU	L7L000012
4	Desktop PC	H	Dell	DCNE	53FMFC1
5	Monitor	P	Dell	E156FPf	CN-0Y9998-72872-5BN-1KET
6	Keyboard	P	Dell	L100	CN-0RH659-73571-14C-0926
7	Modem (MDM-01)	P	US Robotics	0701	22SBBAC9FPMN
8	Mouse (MS-01)	P	Microsoft	X802382-002	None

\* Type: E = EUT, P = Peripheral, S = Support Equipment; H = Host Computer

**List of Cables**

QTY	Length (m)	Cable Description	Shielded?
1	1.85	USB Cable to Card Reader	Yes
1	1.1	Serial Cable from modem to computer	Yes
1	1.8	AC Cord to Computer	No

#### 4.2 Special Accessories

No special accessories were used during the tests in order to achieve compliance.

### 4.3 Equipment Modifications

No modifications were made at Radiometrics in order to meet the requirements listed in this report.

## 5 TEST SPECIFICATIONS AND RELATED DOCUMENTS

Document	Date	Title
FCC CFR Title 47	2016	Code of Federal Regulations Title 47, Chapter 1, Federal Communications Commission, Part 15 - Radio Frequency Devices
ANSI C63.10-2013	2013	American National Standard for Testing Unlicensed Wireless Devices
IC RSS-210 Issue 9	2016	Low Power Licence-Exempt Radiocommunication Devices (All Frequency Bands) Category I Equipment
IC RSS-Gen Issue 4	2014	General Requirements and Information for the Certification of Radiocommunication Equipment (RSS-Gen)

The test procedures used are in accordance with the Industry Canada RSS-Gen and ANSI document C63.10-2013. The specific procedures are described herein.

## 6 RADIOMETRICS' TEST FACILITIES

The results of these tests were obtained at Radiometrics Midwest Corp. in Romeoville, Illinois, USA. Radiometrics is accredited by A2LA (American Association for Laboratory Accreditation) to conform to ISO/IEC 17025: 2005 "General Requirements for the Competence of Calibration and Testing Laboratories". Radiometrics' Lab Code is 121191 and Certification Number is 1495.01. Radiometrics' scope of accreditation includes all of the test methods listed herein. A copy of the accreditation can be accessed on our web site ([www.radiomet.com](http://www.radiomet.com)). Radiometrics accreditation status can be verified at A2LA's web site ([www.a2la2.org](http://www.a2la2.org)).

The following is a list of shielded enclosures located in Romeoville, Illinois used during the tests:

Chamber E: Is a custom made anechoic chamber that measures 52' L X 30' W X 18' H. The walls and ceiling are fully lined with RF absorber. Pro-shield of Collinsville, Oklahoma manufactured the chamber.

Test Station F: Is an area that measures 10' D X 12' W X 10' H. The floor and back wall are metal shielded. This area is used for conducted emissions measurements.

A separate ten-foot long, brass plated, steel ground rod attached via a 6 inch copper braid grounds each of the above chambers. Each enclosure is also equipped with low-pass power line filters.

The FCC has accepted these sites as test site number US1065. The FCC test site Registration Number is 732175. Details of the site characteristics are on file with the Industry Canada as site number IC8727A-1.

A complete list of the test equipment is provided herein. The calibration due dates are indicated on the equipment list. The equipment is calibrated in accordance to ANSI/NCSL Z540-1 with traceability to the National Institute of Standards and Technology (NIST).

## 7 DEVIATIONS AND EXCLUSIONS FROM THE TEST SPECIFICATIONS

There were no deviations or exclusions from the test specifications.

# RADIOMETRICS MIDWEST CORPORATION - EMC Test Report

Testing of RF IDEas, Model RDR-7L82AKU, Multi-Protocol RFID Reader

## 8 CERTIFICATION

Radiometrics Midwest Corporation certifies that the data contained herein was taken under conditions that meet or exceed the requirements of the test specification. The results relate only to the EUT listed herein. Any modifications made to the EUT subsequent to the indicated test date will invalidate the data and void this certification.

## 9 TEST EQUIPMENT TABLE

RMC ID	Manufacturer	Description	Model No.	Serial No.	Frequency Range	Cal Period	Cal Date
AMP-22	Anritsu	Pre-amplifier	MH648A	M23969	0.1-1200MHz	12 Mo.	01/09/17
ANT-03	Tensor	Biconical Antenna	4104	2231	20-250MHz	24 Mo.	12/07/15
ANT-04	Tensor	Biconical Antenna	4104	2246	20-250MHz	24 Mo.	05/16/16
ANT-06	EMCO	Log-Periodic Ant.	3146	1248	200-1000MHz	24 Mo.	11/25/15
ANT-08	RMC	Log-Periodic Ant.	LP1000	1002	200-1000MHz	24 Mo.	10/06/16
ANT-53	EMCO	Loop Antenna	6507	1453	1 kHz-30 MHz	24 Mo.	12/17/15
LSN-01	Electrometrics	50 uH LISN	FCC/VDE 50/2	1001	0.01-30MHz	24 Mo.	06/23/15
LSN-03	Farnell	50 uH LISN	1EXLSN30B	000314	0.15-30MHz	24 Mo.	06/23/15
REC-20	HP / Agilent	Spectrum Analyzer	85460A/84562A	33330A00135 3410A00178	30Hz-6GHz	24 Mo.	06/26/15
REC-21	Agilent	Spectrum Analyzer	E7405A	MY45118341	9kHz-26.5 GHz	24 Mo.	12/22/15
REC-43	Adventest	Spectrum Analyzer	U3772	150800305	9kHz-43GHz	24 Mo.	04/19/17
THM-03	Fluke	Temp/Humid Meter	971	95850465	N/A	12 Mo.	02/20/17

Note: All calibrated equipment is subject to periodic checks.

## 10 TEST SECTIONS

### 10.1 AC Conducted Emissions

The tests and limits are in accordance with FCC section 15.207 and RSS Gen section 8.8.

A computer-controlled analyzer was used to perform the conducted emissions measurements. The frequency range was divided into 500 subranges equally spaced on a logarithmic scale. The computer recorded the peak of each subrange. This data was then plotted on a semi-log graph generated by the computer. Adjusting the positions of the cables and orientation of the test system then maximizes the highest emissions.

Mains Conducted emission measurements were performed using a 50 Ohm/50 uH Line Impedance Stabilization Network (LISN) as the pick-up device. Measurements were repeated on both leads within the power cord. If the EUT power cord exceeded 80 cm in length, the excess length of the power cord was made into a 30 to 40 cm bundle near the center of the cord. The LISN was placed on the floor at the base of the test platform and electrically bonded to the ground plane.

#### FCC/IC Limits of Conducted Emissions at the AC Mains Ports

Frequency Range (MHz)	Class B Limits (dBuV)	
	Quasi-Peak	Average
0.150 - 0.50*	66 - 56	56 - 46
0.5 - 5.0	56	46
5.0 - 30	60	50

\* The limit decreases linearly with the logarithm of the frequency in this range.

The initial step in collecting conducted data is a peak detector scan and the plotting of the measurement range. Significant peaks are then marked as shown on the following table, and these signals are then measured with the quasi-peak detector. The following represents the worst case emissions from the host computer (with the EUT connected) power cord, after testing all modes of operation.

In accordance with the FCC rules regarding transmitters below 30 MHz.

The transmitter was tested with a dummy load under the following conditions:

- 1) First, the AC line conducted tests with the antenna attached were performed to determine if the EUT complies with the 15.207 limits outside of the transmitter's fundamental emission band.
- 2) The AC line conducted emissions were retested with a dummy load to make sure the device complies with the 15.207 limits inside the transmitter's fundamental emission band. Only the fundamental TX emission band needs to be retested. The load was 100 Ohm. This is the characteristic impedance of the antenna.

Test Date: May 2, 2017

QP readings are quasi-peak with a 9 kHz bandwidth and no video filter.

Judgment: Passed by at more than 10 dB at 13.56 MHz with Resistive Load in place of standard Loop antenna.

Judgment: Passed by at least 5.0 dB at all frequencies except 13.56 MHz with standard Loop antenna installed.

# RADIOMETRICS MIDWEST CORPORATION - EMC Test Report

Testing of RF IDEas, Model RDR-7L82AKU, Multi-Protocol RFID Reader

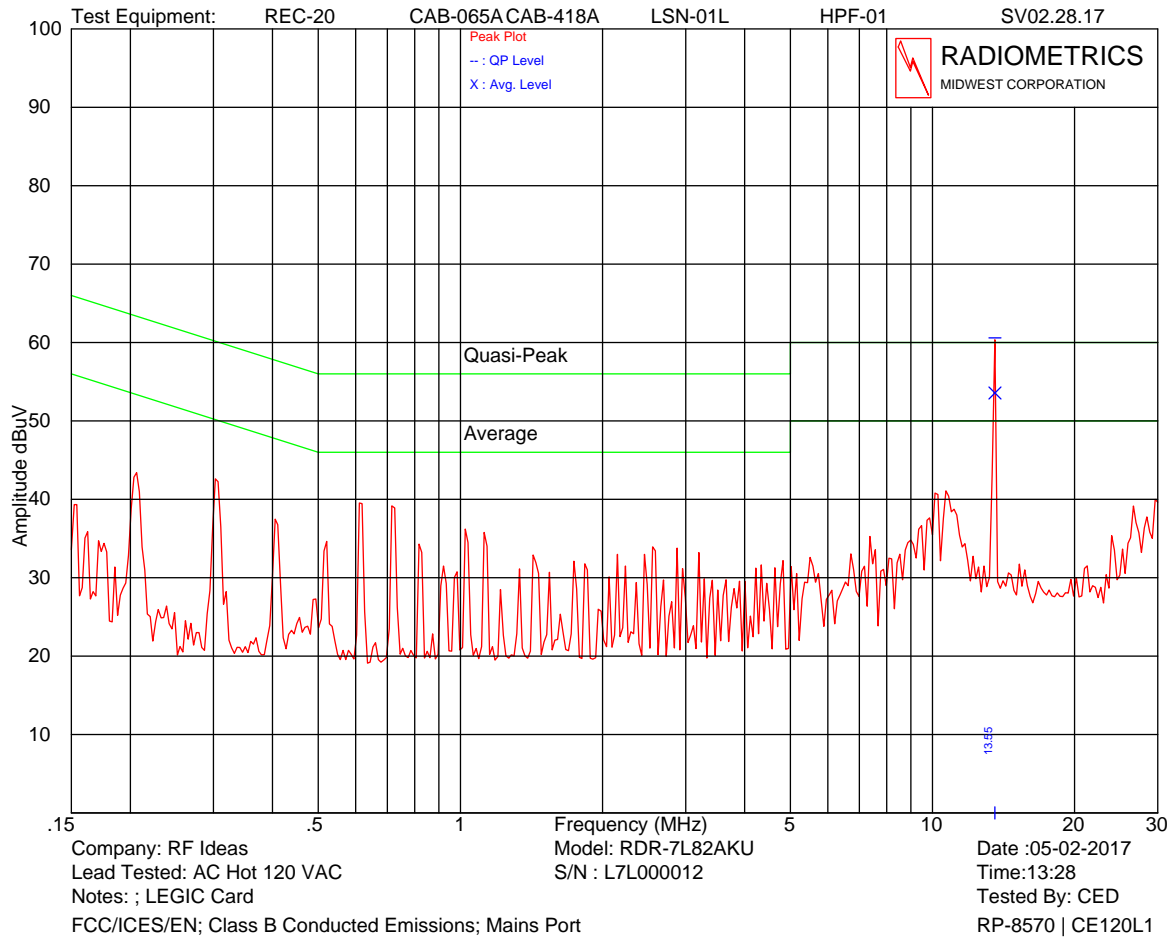

Model: RDR-7L82AKU; with standard antenna installed

Frequency (MHz)	QP Amplitude (dBuV)	QP Limit (dBuV)	Average Amplitude (dBuV)	Average Limit (dBuV)	Margin (dB)
13.56	60.6	60.0	53.5	50.0	-3.5
0.206	43.4	63.4	43.4	53.4	10.0
0.303	42.6	60.2	42.6	50.2	7.5
0.405	37.5	57.7	37.5	47.7	10.3
0.611	39.5	56.0	39.5	46.0	6.5
0.716	39.2	56.0	39.2	46.0	6.8
10.125	40.8	60.0	40.8	50.0	9.2
10.260	40.6	60.0	40.6	50.0	9.4
10.676	41.1	60.0	41.1	50.0	8.9
10.819	40.4	60.0	40.4	50.0	9.6
29.605	40.0	60.0	40.0	50.0	10.0
30.000	39.6	60.0	39.6	50.0	10.4

The emission at 13.56 MHz was re-measured with a resistive load in place of the antenna and was fully compliant.

Except at 13.56 MHz, all readings are peak, since they passed the average limit.



# RADIOMETRICS MIDWEST CORPORATION - EMC Test Report

## Testing of RF IDEas, Model RDR-7L82AKU, Multi-Protocol RFID Reader

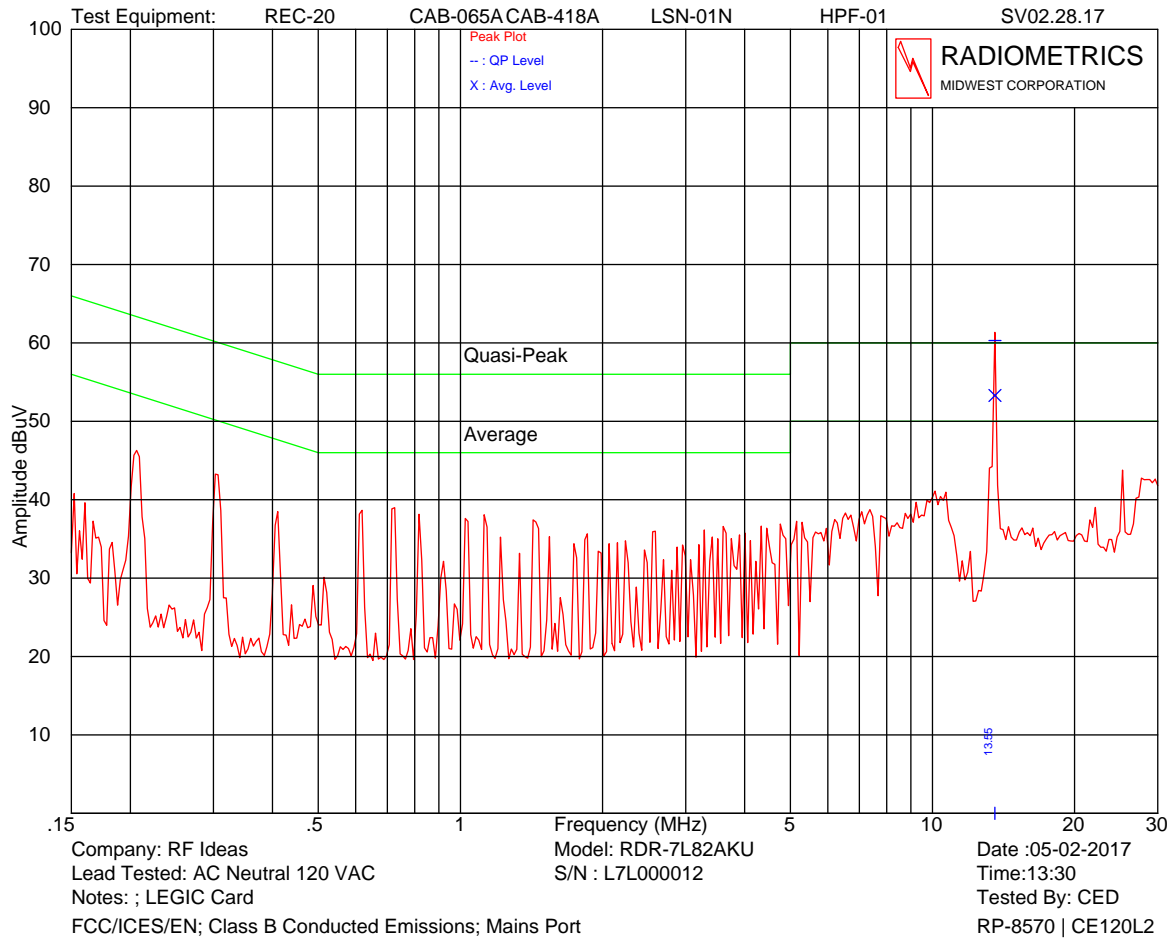

Model: RDR-7L82AKU; with standard antenna installed

Frequency (MHz)	QP Amplitude (dBuV)	QP Limit (dBuV)	Average Amplitude (dBuV)	Average Limit (dBuV)	Margin (dB)
13.56	60.3	60	53.3	50	-3.3
0.206	46.3	63.4	46.3	53.4	7.1
0.303	43.3	60.2	43.3	50.2	6.9
0.726	39.0	56.0	39.0	46.0	7.0
10.125	41.1	60.0	41.1	50.0	8.9
25.254	43.8	60.0	43.8	50.0	6.2
27.343	40.4	60.0	40.4	50.0	9.6
27.708	42.7	60.0	42.7	50.0	7.3
28.078	42.5	60.0	42.5	50.0	7.5
28.452	42.6	60.0	42.6	50.0	7.4
29.216	43.7	60.0	43.7	50.0	6.3

The emission at 13.56 MHz was re-measured with a resistive load in place of the antenna and was fully compliant.

Except at 13.56 MHz, all readings are peak, since they passed the average limit.

# RADIOMETRICS MIDWEST CORPORATION - EMC Test Report

Testing of RF IDEas, Model RDR-7L82AKU, Multi-Protocol RFID Reader

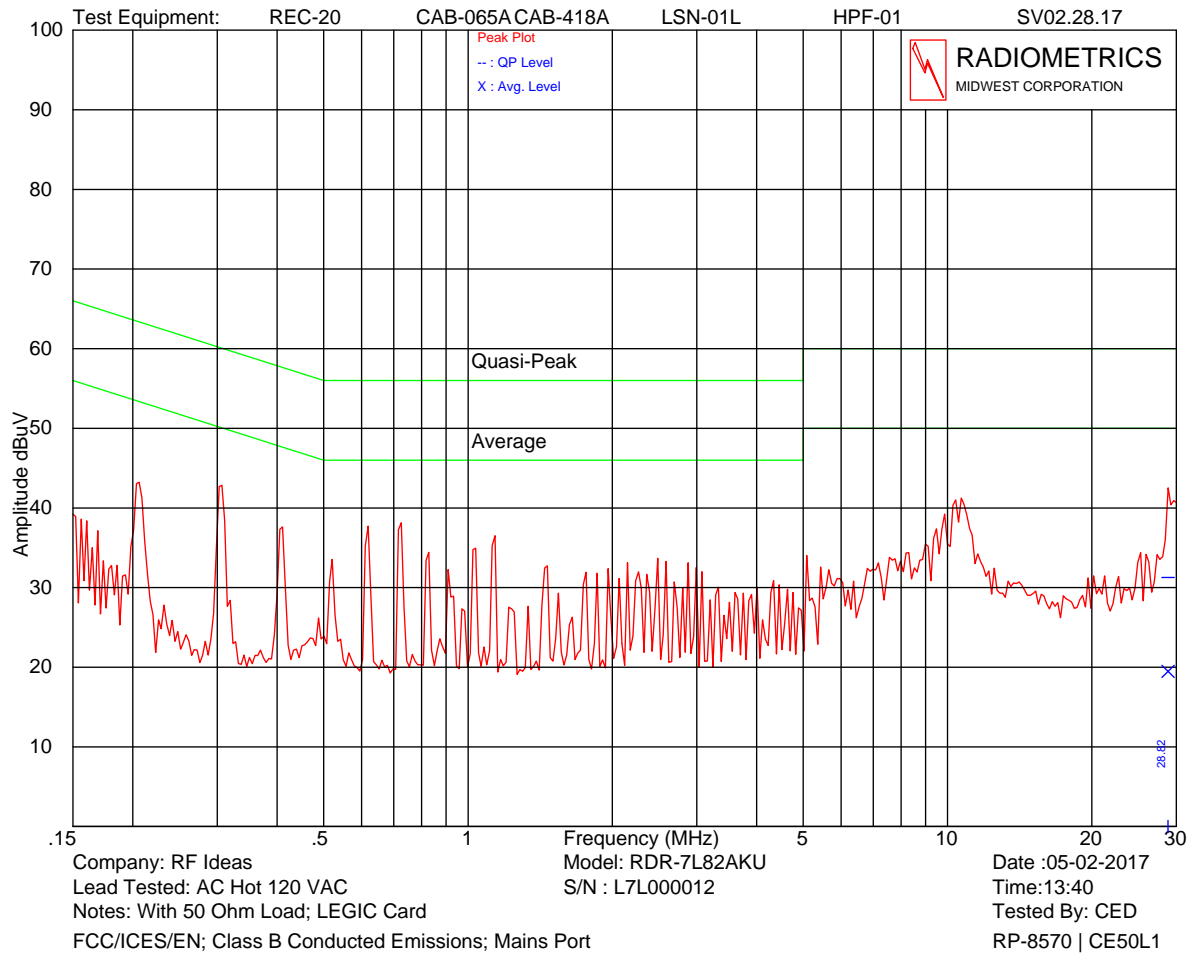

Model: RDR-7L82AKU; With 50 Ohm load in place of antenna

Frequency (MHz)	QP Amplitude (dBuV)	QP Limit (dBuV)	Average Amplitude (dBuV)	Average Limit (dBuV)	Margin (dB)
28.8	31.3	60	19.5	50	28.7
0.206	43.2	63.4	43.2	53.4	10.1
0.307	42.9	60.1	42.9	50.1	7.2
0.410	37.6	57.6	37.6	47.6	10.0
0.619	37.7	56.0	37.7	46.0	8.3
0.716	37.3	56.0	37.3	46.0	8.7
0.726	38.1	56.0	38.1	46.0	7.9
1.138	36.5	56.0	36.5	46.0	9.5
9.861	39.2	60.0	39.2	50.0	10.8
10.397	41.0	60.0	41.0	50.0	9.0
10.676	41.2	60.0	41.2	50.0	8.8
29.605	40.9	60.0	40.9	50.0	9.1
30.000	40.7	60.0	40.7	50.0	9.3

Except at 28.8 MHz, all readings are peak, since they passed the average limit.

# RADIOMETRICS MIDWEST CORPORATION - EMC Test Report

Testing of RF IDEas, Model RDR-7L82AKU, Multi-Protocol RFID Reader

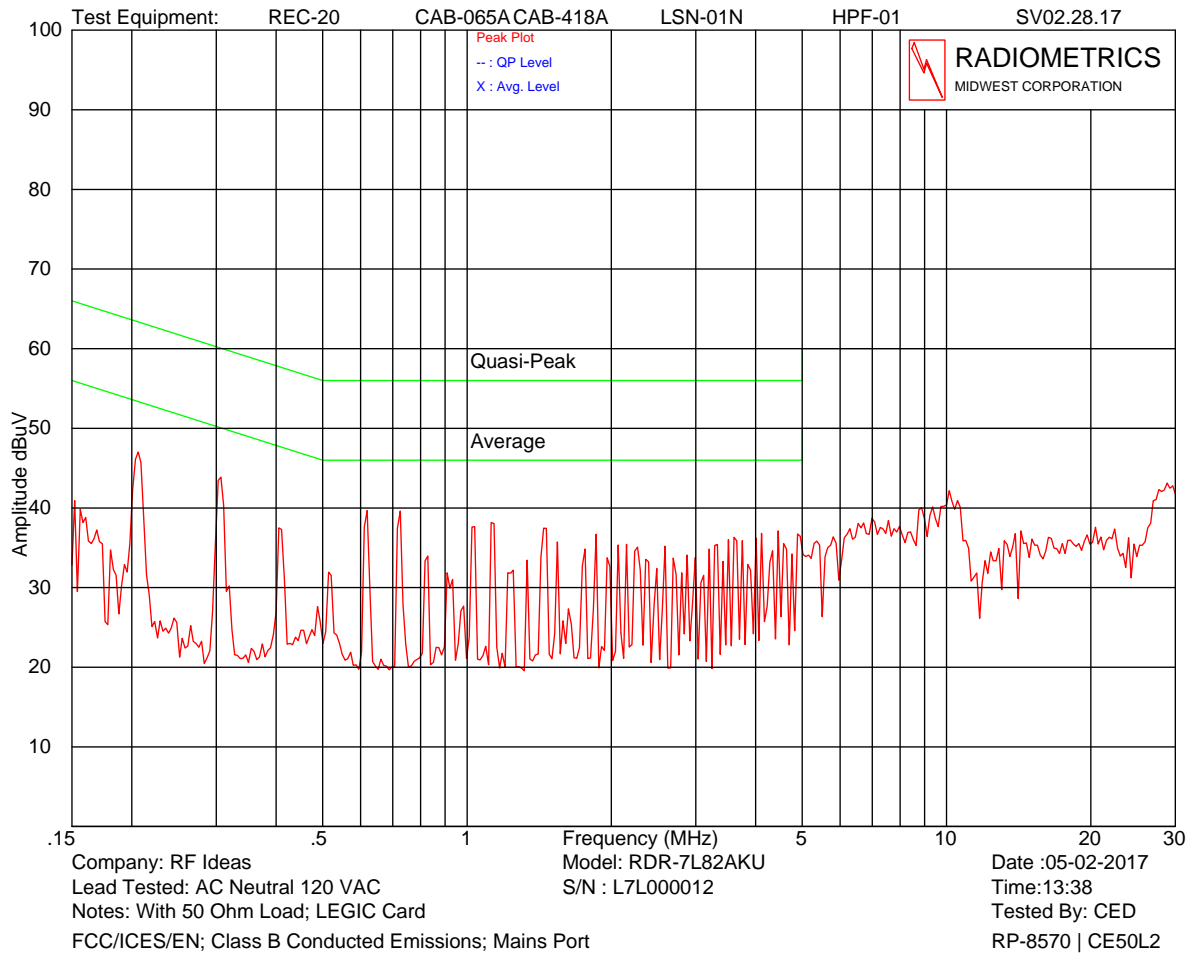

Frequency (MHz)	QP Amplitude (dBuV)	QP Limit (dBuV)	Average Amplitude (dBuV)	Average Limit (dBuV)	Margin (dB)
0.206	47.0	63.4	47.0	53.4	6.3
0.307	43.9	60.1	43.9	50.1	6.2
0.619	39.7	56.0	39.7	46.0	6.3
0.726	39.6	56.0	39.6	46.0	6.4
9.992	40.4	60.0	40.4	50.0	9.6
10.125	42.2	60.0	42.2	50.0	7.8
27.343	41.1	60.0	41.1	50.0	8.9
27.708	42.3	60.0	42.3	50.0	7.7
28.452	42.3	60.0	42.3	50.0	7.7
28.831	43.6	60.0	43.6	50.0	6.4
29.605	42.8	60.0	42.8	50.0	7.2
30.000	41.8	60.0	41.8	50.0	8.2

Model: RDR-7L82AKU; With 50 Ohm load in place of antenna

All readings are peak, since they passed the average limit.

Figure 1. Conducted Emissions Test Setup

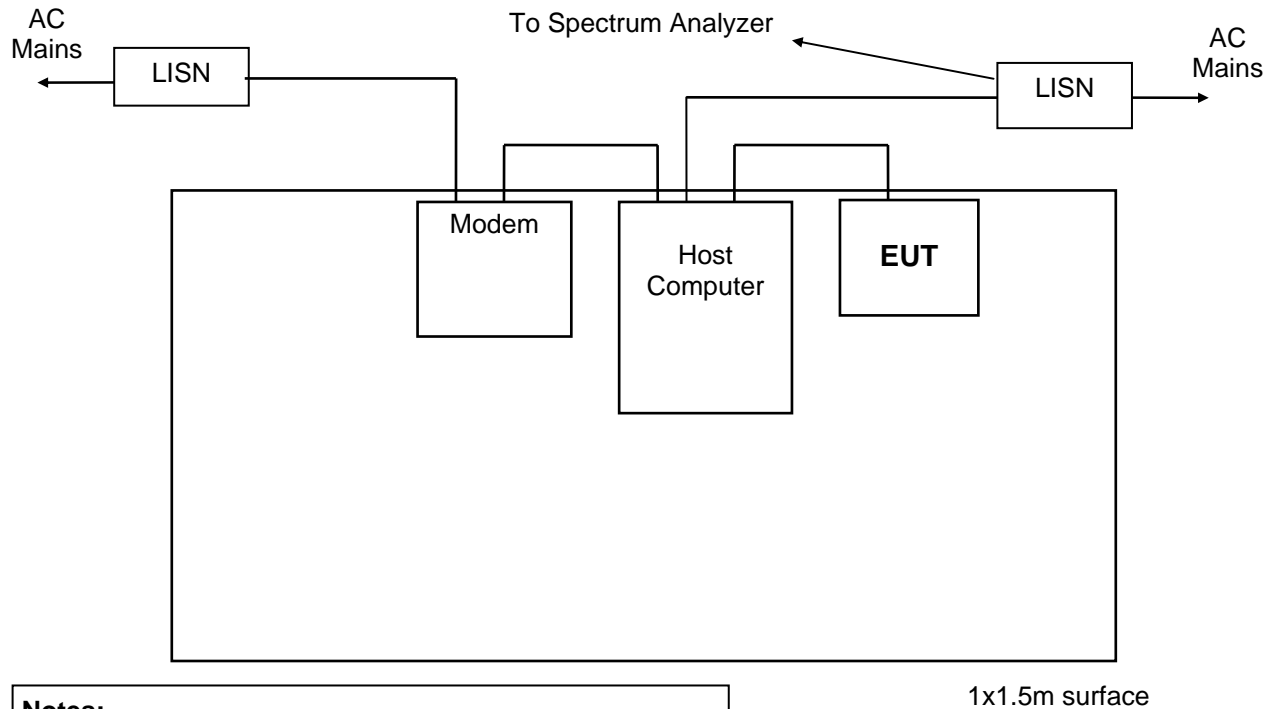
**Notes:**

- LISN's at least 80 cm from EUT chassis
- Vertical conductive plane 40 cm from rear of table top
- EUT power cord bundled

1x1.5m surface

## 10.2 Radiated RF Emissions

Radiated emission measurements were performed with linearly polarized broadband antennas. The results obtained with these antennas can be correlated with results obtained with a tuned dipole antenna. The radiated emission measurements were performed with a spectrum analyzer. The bandwidth used from 150 kHz to 30 MHz is 9 or 10 kHz and the bandwidth from 30 MHz to 1000 MHz is 100 or 120 kHz. Above 1 GHz, a 1 MHz bandwidth is used. A 10 dB linearity check is performed prior to start of testing in order to determine if an overload condition exists. Figure 4 herein lists the details of the test equipment used during radiated emissions tests.

Final radiated emissions measurements were performed inside of an anechoic chamber at a test distance of 3 meters. The anechoic chamber is designated as Chamber E. This Chamber meets the Site Attenuation requirements of ANSI C63.4 and CISPR 16-1. Chamber E is located at 12 East Devonwood Ave. Romeoville, Illinois EMI test lab.

The entire frequency range from 30 to 1000 MHz was slowly scanned with particular attention paid to those frequency ranges which appeared high. Measurements were performed using two antenna polarizations, (vertical and horizontal). The worst case emissions were recorded. All measurements may be performed using either the peak, average or quasi-peak detector functions. If the peak detector data exceeds or is marginally close to the limits, the measurements are repeated using a quasi-peak detector or average function as required by the specification for final determination of compliance.

**RADIOMETRICS MIDWEST CORPORATION - EMC Test Report**

Testing of RF IDEas, Model RDR-7L82AKU, Multi-Protocol RFID Reader

The detected emission levels were maximized by rotating the EUT, adjusting the positions of all cables, and by scanning the measurement antenna from 1 to 4 meters above the ground.

**Radiated Emissions Field Strength Limits**

Frequency Range (MHz)	Test Distance (meters)	FCC Class B Limits (uV/m)		
		QP	Average	Peak
0.009-0.490	300	2400/F(kHz)	N/A	N/A
0.490-1.705	30	24000/F(kHz)	N/A	N/A
1.705-30.0	30	30	N/A	N/A
30 - 88	3	40.0	N/A	N/A
88 - 216	3	43.5	N/A	N/A
216 - 960	3	46.0	N/A	N/A
960 - 1000	3	54	N/A	N/A

An Average detector can be used for 9-90 kHz and 110-490 kHz.

**10.2.1 Field Strength Calculation**

The field strength is calculated by adding the Antenna Factor and Cable Loss, and by subtracting the Amplifier Gain from the measured reading. The basic equation is as follows:

$$FS = RA + AF + CF - AG$$

Where: FS = Field Strength

RA = Receiver Amplitude

AF = Antenna Factor

CF = Cable Attenuation Factor

AG = Amplifier Gain

**10.2.2 Radiated Emissions Test Results**

Company	RF IDEas	Specification	FCC Part 15 Subpart C & RSS-210
Model	RDR-7L82AKU	Test Date	05/02/2017
Serial Number	L7L000012	Test Distance	3 Meters
Test Personnel	Chris Dalessio	Test Location	Chamber E
Abbreviations	Pol = Antenna Polarization; V = Vertical; H = Horizontal Det.= Detector setting; A = Average; P = peak; Q = QP;		

Note: The actual FCC limits are in uV/m. The data in the table below covered the limit to dBuV/m.

100 uV/m = 40.0 dBuV/m

150 uV/m = 43.5 dBuV/m

200 uV/m = 46.0 dBuV/m

500 uV/m = 54.0 dBuV/m

No card on reader

Freq. MHz	Meter Reading dBuV	Dect.	Ant. Pol.	Ant Factor	Cable & Amp Factors	Dist Fact dB	EUT dBuV/m	Limit dBuV/m	Margin Under Limit dB	Note
33.3	18.1	P	H	11.4	0.5	0.0	30.0	40.0	10.0	
62.5	17.4	P	H	8.5	0.6	0.0	26.5	40.0	13.5	
133.4	16.2	P	H	11.7	1.0	0.0	28.9	43.5	14.6	
149.4	12.8	P	H	13.1	1.0	0.0	26.9	43.5	16.6	
200.5	15.5	P	H	16.3	1.2	0.0	33.0	43.5	10.5	
241.8	15.2	P	H	15.9	1.3	0.0	32.4	46.0	13.6	

**RADIOMETRICS MIDWEST CORPORATION - EMC Test Report**

Testing of RF IDEas, Model RDR-7L82AKU, Multi-Protocol RFID Reader

Freq. MHz	Meter Reading dBuV	Decet.	Ant. Pol.	Ant Factor	Cable & Amp Factors	Dist Fact dB	EUT dBuV/m	Limit dBuV/m	Margin Under Limit dB	Note
257.4	12.4	P	H	11.6	1.3	0.0	25.3	46.0	20.7	
302.2	15.9	P	H	14.6	1.5	0.0	32.0	46.0	14.0	
349.6	18.4	P	H	14.0	1.6	0.0	34.0	46.0	12.0	
362.6	16.2	P	H	14.3	1.6	0.0	32.1	46.0	13.9	
422.5	13.2	P	H	15.7	1.7	0.0	30.6	46.0	15.4	
432.2	13.8	P	H	15.7	1.8	0.0	31.3	46.0	14.7	
488.1	16.4	P	H	17.4	1.9	0.0	35.7	46.0	10.3	
501.8	16.7	P	H	17.8	1.9	0.0	36.4	46.0	9.6	
516.3	14.9	P	H	17.8	1.9	0.0	34.6	46.0	11.4	
530.0	14.8	P	H	16.7	2.0	0.0	33.5	46.0	12.5	
665.0	12.5	P	H	19.6	2.3	0.0	34.4	46.0	11.6	
786.3	13.1	P	H	20.8	2.5	0.0	36.4	46.0	9.6	
906.3	12.3	P	H	22.1	2.6	0.0	37.0	46.0	9.0	
966.3	13.0	P	H	22.4	2.7	0.0	38.1	54.0	15.9	
36.6	20.5	P	V	11.7	0.5	0.0	32.7	40.0	7.3	
51.5	16.8	P	V	11.1	0.6	0.0	28.5	40.0	11.5	
60.3	18.9	P	V	9.0	0.6	0.0	28.5	40.0	11.5	
77.3	20.4	P	V	6.5	0.7	0.0	27.6	40.0	12.4	
103.2	18.3	P	V	12.0	0.8	0.0	31.1	43.5	12.4	
133.4	19.3	P	V	11.7	1.0	0.0	32.0	43.5	11.5	
149.4	16.3	P	V	13.1	1.0	0.0	30.4	43.5	13.1	
176.3	15.3	P	V	16.7	1.1	0.0	33.1	43.5	10.4	
209.9	15.2	P	V	15.3	1.2	0.0	31.7	43.5	11.8	
258.0	11.9	P	V	18.0	1.4	0.0	31.3	46.0	14.7	
275.5	14.1	P	V	13.1	1.4	0.0	28.6	46.0	17.4	
278.8	13.8	P	V	19.6	1.4	0.0	34.8	46.0	11.2	
332.8	18.0	P	V	13.8	1.5	0.0	33.3	46.0	12.7	
349.6	18.7	P	V	14.0	1.6	0.0	34.3	46.0	11.7	
362.6	14.9	P	V	14.3	1.6	0.0	30.8	46.0	15.2	
406.9	14.2	P	V	14.9	1.7	0.0	30.8	46.0	15.2	
432.2	15.9	P	V	15.7	1.8	0.0	33.4	46.0	12.6	
488.1	15.5	P	V	17.4	1.9	0.0	34.8	46.0	11.2	
543.8	13.8	P	V	18.0	2.0	0.0	33.8	46.0	12.2	
665.0	12.8	P	V	19.6	2.3	0.0	34.7	46.0	11.3	
820.0	12.0	P	V	21.1	2.6	0.0	35.7	46.0	10.3	
966.3	13.4	P	V	22.4	2.7	0.0	38.5	54.0	15.5	
Notes		With Card 13.56 MHz Card								
40.5	14.6	P	H	12.0	0.5	0.0	27.1	40.0	12.9	
63.5	15.9	P	H	8.2	0.6	0.0	24.7	40.0	15.3	
137.3	13.7	P	H	11.6	1.0	0.0	26.3	43.5	17.2	
149.4	19.1	P	H	13.1	1.0	0.0	33.2	43.5	10.3	
176.3	12.3	P	H	16.7	1.1	0.0	30.1	43.5	13.4	
241.8	16.6	P	H	15.9	1.3	0.0	33.8	46.0	12.2	
257.4	15.2	P	H	11.6	1.3	0.0	28.1	46.0	17.9	
284.6	13.7	P	H	13.6	1.4	0.0	28.7	46.0	17.3	
302.2	16.4	P	H	14.6	1.5	0.0	32.5	46.0	13.5	
334.0	16.4	P	H	13.8	1.5	0.0	31.7	46.0	14.3	
349.0	17.2	P	H	14.0	1.6	0.0	32.8	46.0	13.2	
362.6	16.1	P	H	14.3	1.6	0.0	32.0	46.0	14.0	
432.2	15.5	P	H	15.7	1.8	0.0	33.0	46.0	13.0	
488.1	16.1	P	H	17.4	1.9	0.0	35.4	46.0	10.6	
489.4	17.2	P	H	17.3	1.9	0.0	36.4	46.0	9.6	
516.3	15.3	P	H	17.8	1.9	0.0	35.0	46.0	11.0	

**RADIOMETRICS MIDWEST CORPORATION - EMC Test Report**

Testing of RF IDEas, Model RDR-7L82AKU, Multi-Protocol RFID Reader

Freq. MHz	Meter Reading dBuV	Dect.	Ant. Pol.	Ant Factor	Cable & Amp Factors	Dist Fact dB	EUT dBuV/m	Limit dBuV/m	Margin Under Limit dB	Note
532.5	13.2	P	H	16.8	2.0	0.0	32.0	46.0	14.0	
543.8	14.1	P	H	18.0	2.0	0.0	34.1	46.0	11.9	
605.0	14.5	P	H	18.2	2.1	0.0	34.8	46.0	11.2	
665.0	14.1	P	H	19.6	2.3	0.0	36.0	46.0	10.0	
692.5	13.1	P	H	21.1	2.3	0.0	36.5	46.0	9.5	
833.8	12.6	P	H	22.0	2.5	0.0	37.1	46.0	8.9	
846.3	13.1	P	H	21.8	2.5	0.0	37.4	46.0	8.6	
966.3	14.5	P	H	22.4	2.7	0.0	39.6	54.0	14.4	
36.6	21.8	Q	V	11.7	0.5	0.0	34.0	40.0	6.0	
40.5	21.5	P	V	12.0	0.5	0.0	34.0	40.0	6.0	
52.0	19.7	P	V	11.0	0.6	0.0	31.3	40.0	8.7	
52.0	18.1	P	V	11.0	0.6	0.0	29.7	40.0	10.3	
67.9	23.3	P	V	7.2	0.7	0.0	31.2	40.0	8.8	
77.8	20.9	P	V	6.5	0.7	0.0	28.1	40.0	11.9	
124.6	15.3	P	V	12.1	0.9	0.0	28.3	43.5	15.2	
133.4	18.7	P	V	11.7	1.0	0.0	31.4	43.5	12.1	
149.4	21.8	Q	V	13.0	1.0	0.0	35.8	43.5	7.7	
209.3	13.4	P	V	15.4	1.2	0.0	30.0	43.5	13.5	
224.7	20.1	P	V	14.4	1.2	0.0	35.7	46.0	10.3	

Judgment: Passed by 6.0 dB

**Figure 2. Drawing of Radiated Emissions Test Setup**

Chamber E, anechoic

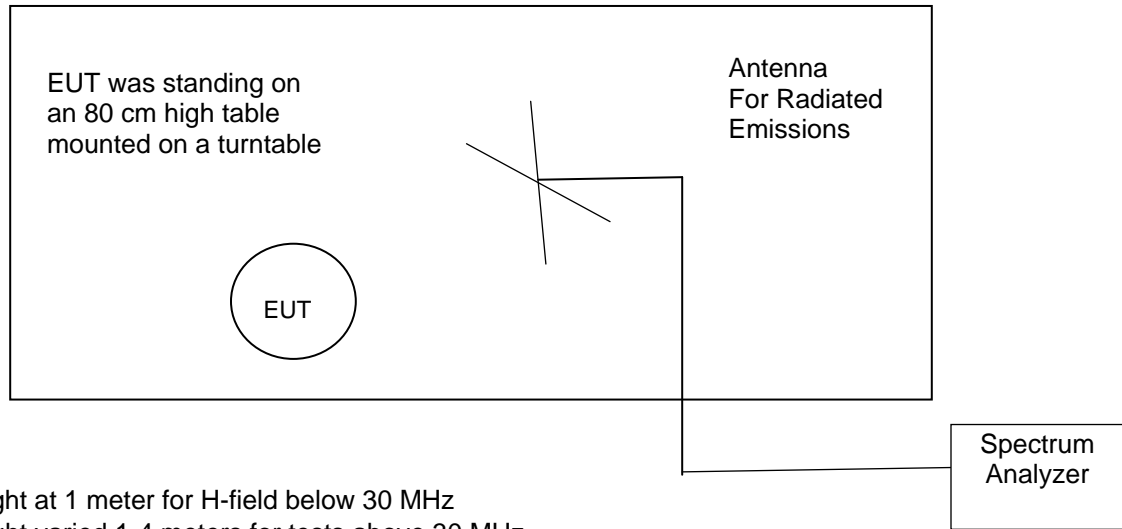

**Notes:**

- Not to Scale
- Antenna height at 1 meter for H-field below 30 MHz
- Antenna height varied 1-4 meters for tests above 30 MHz
- Distance from antenna to tested system is 3 meters
- AC cords not shown. They are connected to AC outlet with low-pass filter on turntable

Frequency Range	Receive Antenna	Pre-Amplifier	Spectrum Analyzer
0.009 to 30 MHz	ANT-53	None	REC-21
30 to 200 MHz	ANT-04	Internal	REC-21
200 to 1000 MHz	ANT-06	Internal	REC-21

**10.3 Magnetic Field Measurements and Decay Factor Calculations**

Radiated emission measurements are performed with an EMCO shielded loop antenna. The antenna was rotated in order to find the maximize readings.

The distance correction factor is calculated as follows:

The distance factor in (dB) =  $DE * 20 * \text{Log}(TD/SD)$

Where: DE = Decay Exponent (2.0 is used for this)

TD = Test distance in meters. This is 3 meters

SD = Specification Distance in meters

From 9 kHz to 490 kHz, the Specification Distance is 300m therefore the distance factor is  $2 * 20 * \text{LOG}(300/3) = 80 \text{ dB}$ .

From 490 kHz to 30 MHz, the Specification Distance is 30m therefore the distance factor is  $2 * 20 * \text{LOG}(30/3) = 40 \text{ dB}$ .



**RADIOMETRICS MIDWEST CORPORATION - EMC Test Report**

Testing of RF IDEas, Model RDR-7L82AKU, Multi-Protocol RFID Reader

**10.3.1 Magnetic Field Radiated Emissions Results (0.009 to 30 MHz)**

Test Date	05/02/2017
Test Distance	3 Meters
Tested by	Chris Dalessio
Specification	FCC 15.209 & RSS-GEN table 5 limit for all frequencies
Notes	A shielded Loop Antenna was used for this test.

**13.56 MHz Frequency**

Freq (MHz)	meter reading dBuV	Loop Ant Factor	Dist (m)	Decay exp	Cable Loss dB	FCC Distance factor dB	Field Strength dBuV/m	RSS & FCC Limit dBuV/m	Margin under limit	EUT tested
13.560	56.1	16.8	3.0	2.0	0.4	-40.0	33.3	40.5	6.7	12
27.120	15.2	16.0	3.0	2.0	0.5	-40.0	-8.3	29.5	37.8	12

The limit shown at 13.56 MHz in the above table is the lowest limit from 15.225 sections (a), (b) and (c).

The limit from 13.553-13.567 MHz at 30 meters is 15,848 uV/m which = 84 dBuV/m in accordance with FCC 15.225 (c) and RSS-210 section B.6 (a).

The limit drops to 334uV/m from 13.410-13.553 MHz and 13.567-13.710 MHz, and 106uV/m = 40.5 dBuV/m from the bands 13.110-13.410 MHz and 13.710-14.010 MHz.

The lower limit (40.5 dBuV/m) was used for all frequencies from 13.110-14.010 MHz.

All other limits are general limits of FCC 15.209 or the RSS-Gen.

The emissions were scanned from 10 kHz to 30 MHz, including 13.11 and 14.01 MHz.

No other emissions were detected from 10 kHz to 30 MHz within 10 dB of the 15.209 or the RSS-GEN limits.

Judgement: Passed by 6.7 dB.

**10.4 Occupied Bandwidth Data**

The occupied bandwidth of the RF output was measured using a spectrum analyzer. The bandwidth was measured using the peak detector function and a narrow resolution bandwidth.

A broadband antenna was used to receive the modulated signal. The spectrum analyzer was set to the MAX HOLD mode to record the worst case of the modulation. The spectrum analyzer display was digitized and plotted. A limit was drawn on the plots based on the level of the modulated carrier. The plots of the occupied bandwidth for the EUT are supplied on the following page.

99% EBW	20 dB OBW
13.56 MHz Signal	kHz
2.245	52.9

The 99% bandwidth was measured using the procedures of RSS-GEN section 6.6.

Judgement: Pass

Figure 3. Occupied Bandwidth Plot: 13.56 MHz

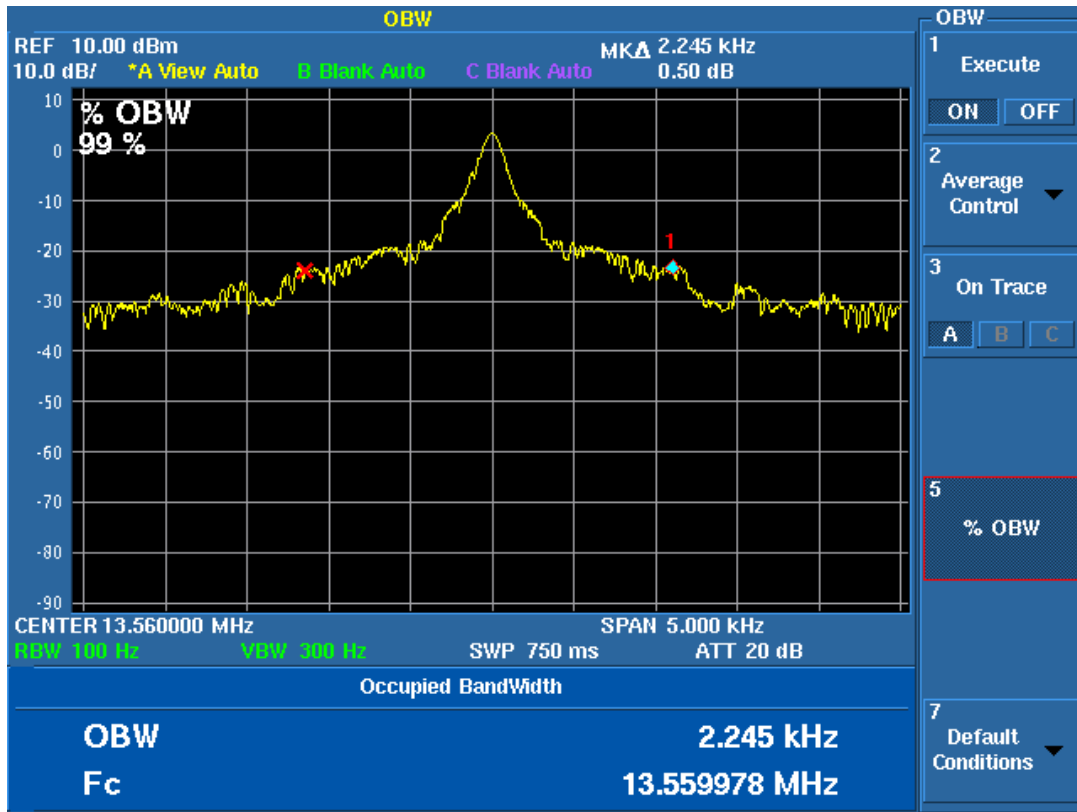

99% Bandwidth = 2.245 kHz

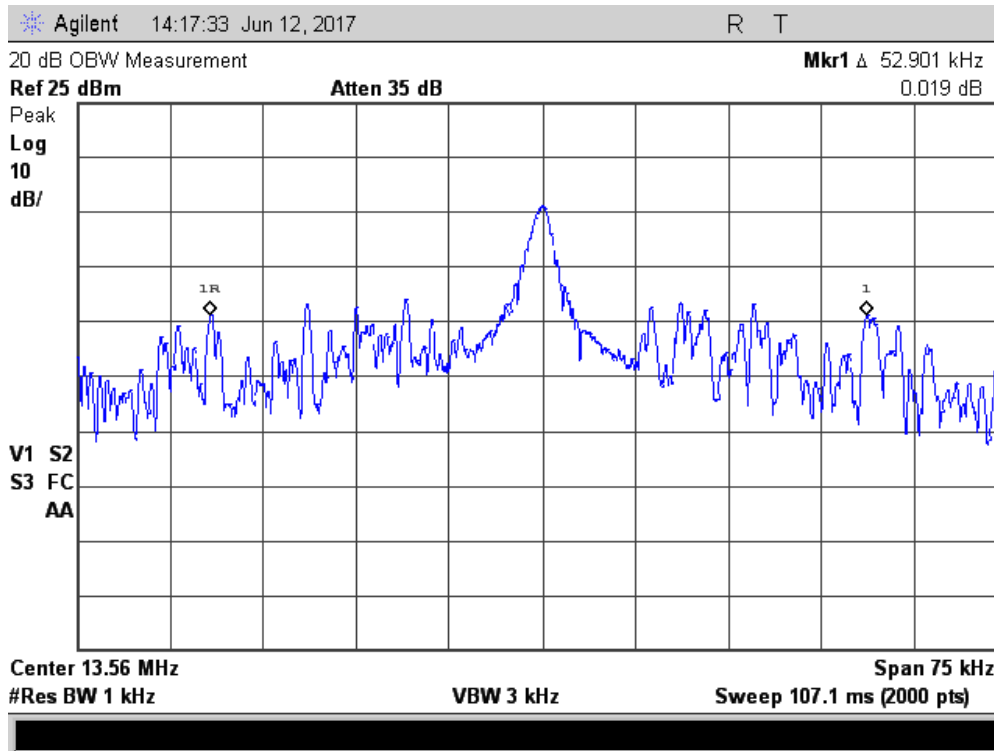

**RADIOMETRICS MIDWEST CORPORATION - EMC Test Report**

Testing of RF IDEas, Model RDR-7L82AKU, Multi-Protocol RFID Reader

**10.5 Frequency Stability**

The tests were in accordance to FCC 15.225 and RSS-210 Section B.6. Since the product is USB powered, a Desktop PC was used to power the device. The input power to the desktop PC was varied by 15%, using a variable AC supply.

**10.5.1 Test Results for Frequency Stability**

Model	RDR-7L82AKU	Specification	FCC Part 15.225 RSS-210 Section B.6
Serial Number	L7L000012	Test Date	05/17/2017
Test Personnel	Richard Tich	Test Location	Station F
Test Equipment	Spectrum Analyzer (REC-21); Temperature Chamber TC-01		
Notes	10 minutes at each Temperature; 1 min at each voltage		
Nominal Frequency	13.560 MHz		

Volts VAC	Freq. (MHz)	Deviation %	PPM
102.0	13.560002	0.00001	0.15
120.0	13.560005	0.00004	0.37
138.0	13.560002	0.00001	0.15

Temp. Deg C	Freq. (@2min.) (MHz)	Freq. (@5min.) (MHz)	Freq. (@10min.) (MHz)	Change from Nominal		
				%	%	%
50	13.560007	13.560007	13.560010	0.00005	0.00005	0.00007
40	13.560002	13.560002	13.560007	0.00001	0.00001	0.00005
30	13.560000	13.560000	13.560000	0.00000	0.00000	0.00000
20	13.559995	13.559995	13.559997	-0.00004	-0.00004	-0.00002
10	13.559992	13.559992	13.559992	-0.00006	-0.00006	-0.00006
0	13.559992	13.559992	13.559992	-0.00006	-0.00006	-0.00006
-10	13.559995	13.559992	13.559992	-0.00004	-0.00006	-0.00006
-20	13.559995	13.559995	13.559987	-0.00004	-0.00004	-0.00010

Test Requirements: Limit is 100 ppm or 0.01% deviation.

Judgement: Pass

## 11 MEASUREMENT INSTRUMENTATION UNCERTAINTY

The uncertainties represent expanded uncertainties expressed at approximately the 95% confidence level using a coverage factor of  $k=2$  in accordance with CISPR 16-4-2.

Measurement	Uncertainty
Conducted Emissions, LISN method, 150 kHz to 30 MHz	2.7 dB
Radiated Emissions, H-field, 3 meters, 9 kHz to 30 MHz	2.7 dB
Radiated Emissions, E-field, 3 meters, 30 to 200 MHz	3.3 dB
Radiated Emissions, E-field, 3 meters, 200 to 1000 MHz	4.9 dB
Frequency counter at 13.56 MHz; REC-21	136 Hz
99% Occupied Bandwidth using REC-43	1% of frequency span
Temperature THM-03	0.6 Deg C