

VHF RX UNIT • EU 231
 Repair Manual • Block Diagram

FCC ID: KVV60431942

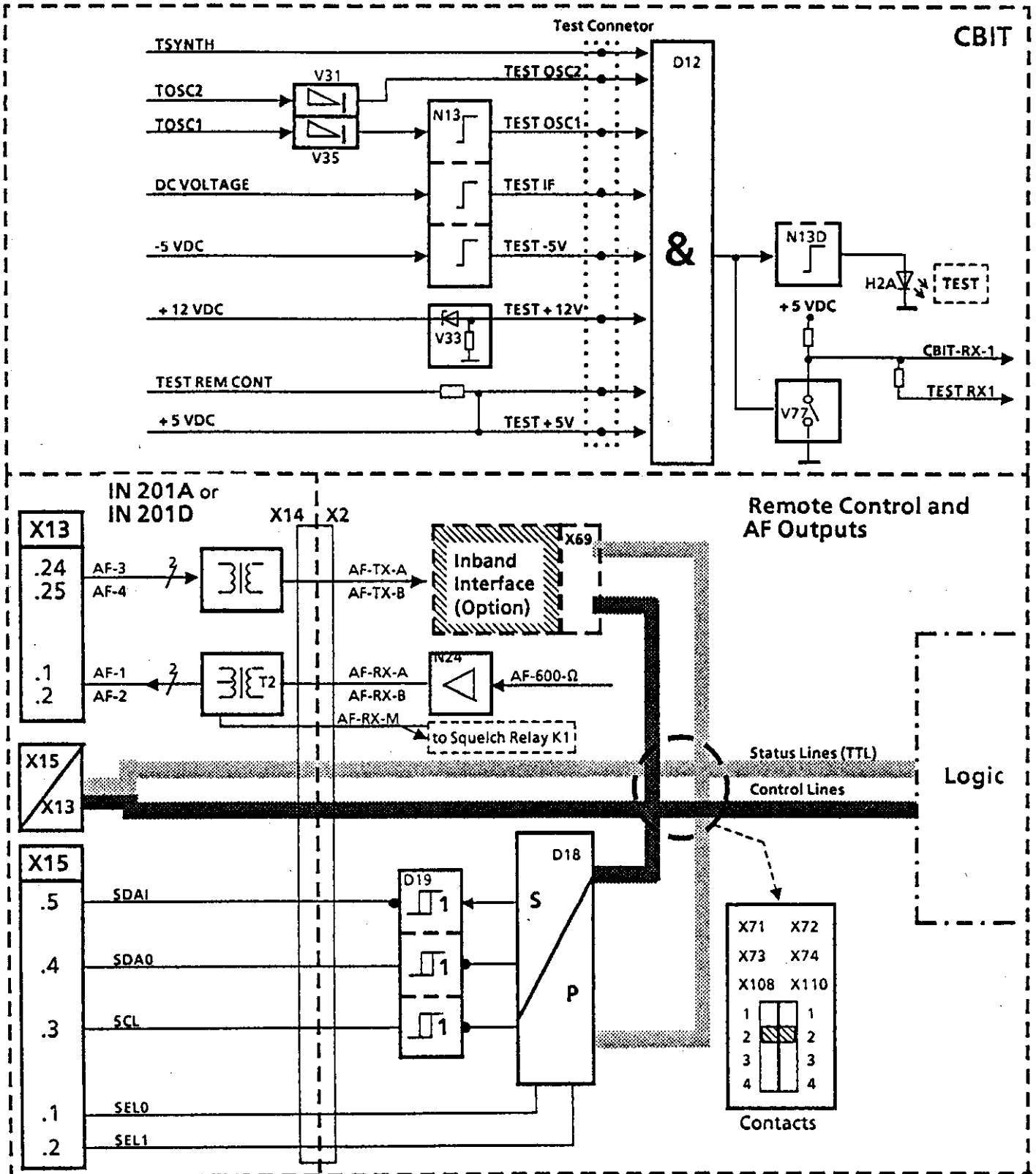

Fig. 5.2 VHF Rx Unit EU 231, Block Diagram (Remote Control and CBIT)

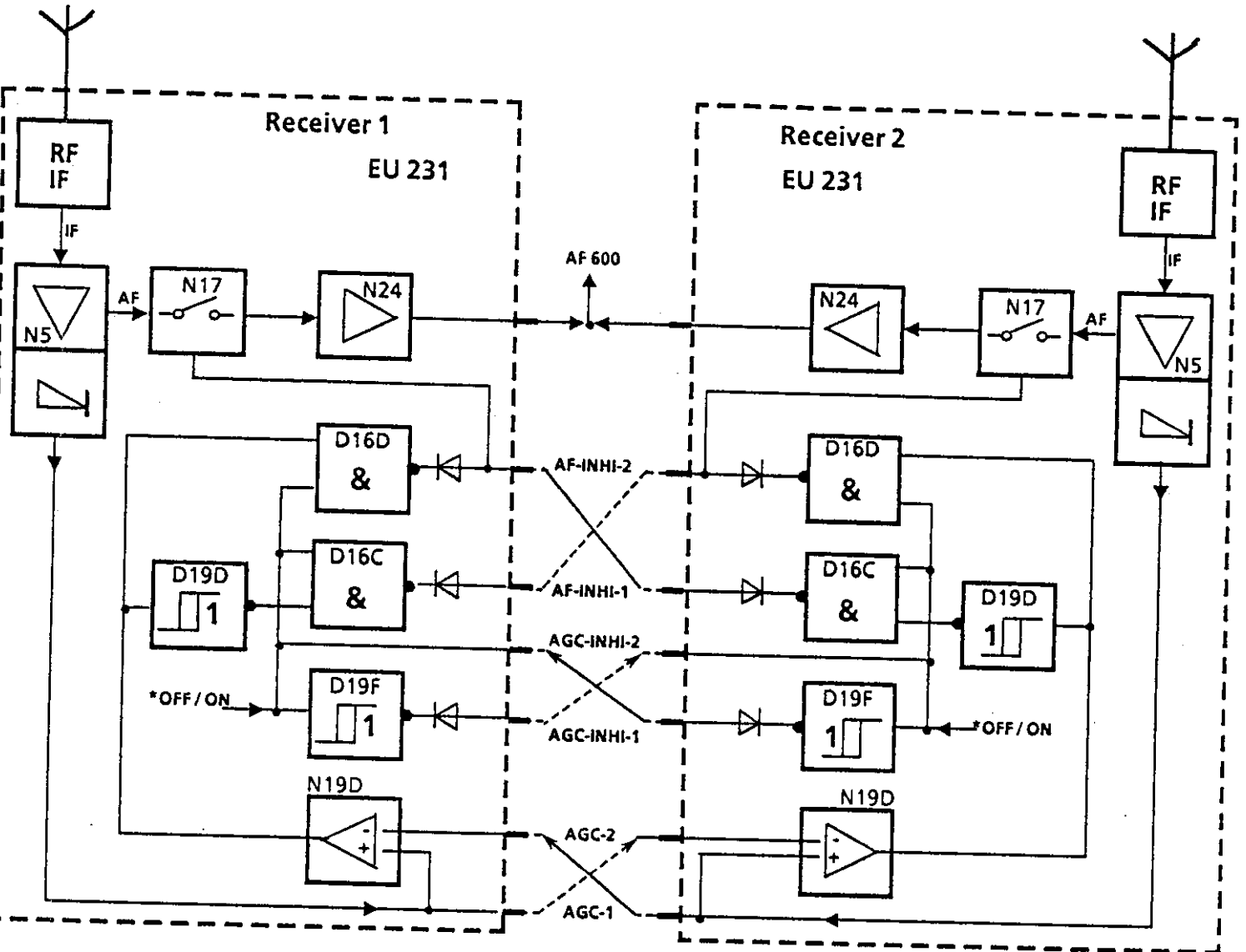

Fig. 5.3 VHF Rx Unit EU 231, Block Diagram (Switchover Operation)

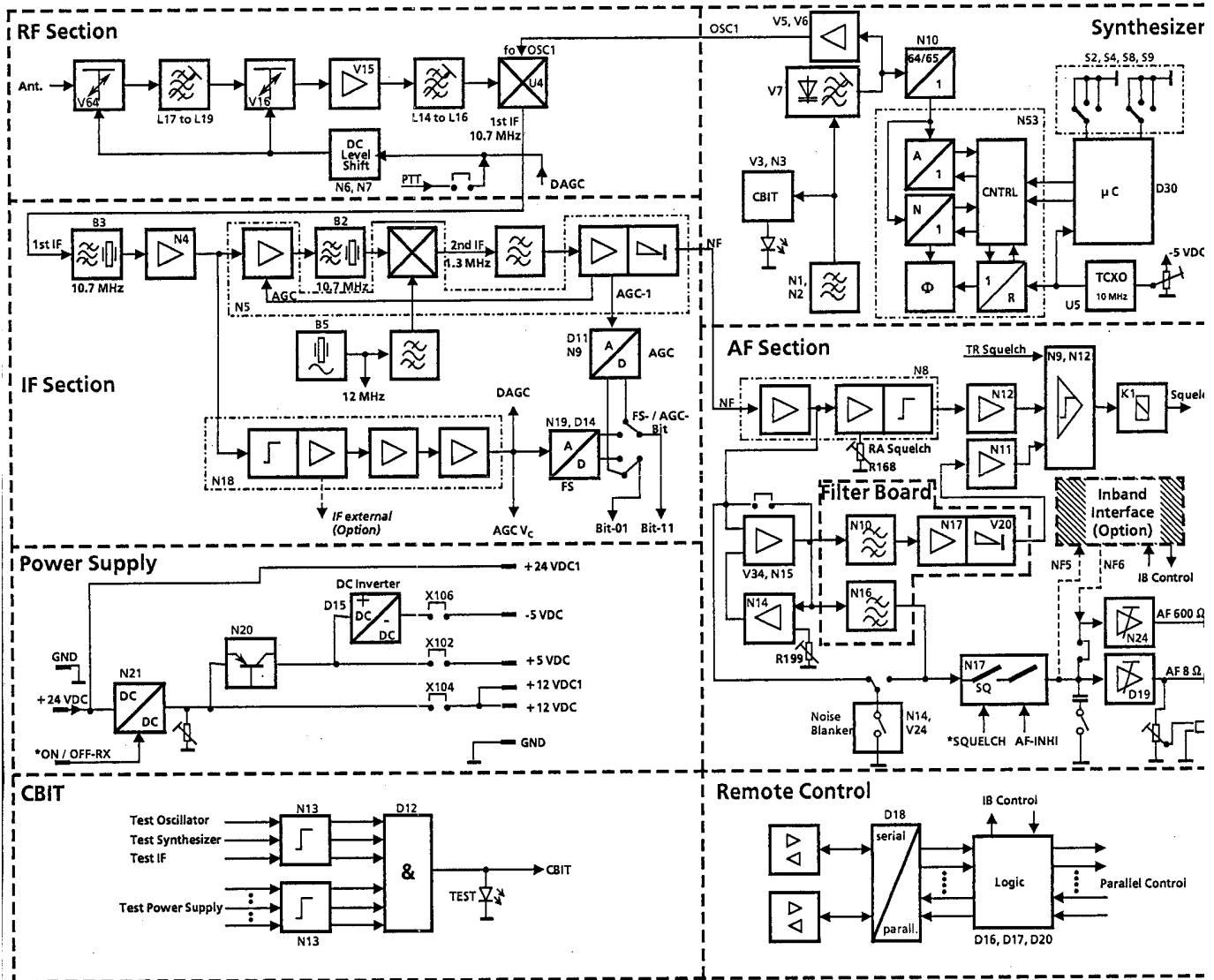

Fig. 5.1 VHF Rx Unit EU 231, Block Diagram
 (RF Section, Synthesizer, AF Section and Power Supply)