

DESCRIPTION AND OPERATION

TASK 34-42-61-870-801-A01

1. DESCRIPTION

A. Principle

The purpose of a Radio Altimeter system is to provide the helicopter with accurate measurements of the minimal distance to the terrain (ground or sea). A Radio Altimeter is a kind of RADAR system, i.e. it uses the fact that the electromagnetic waves propagate through the air at a constant speed c , which is the speed of the light.

B. General

The AHV1600 Transceiver has 2 two mains sub-assembly:

- Digital Chassis,
- Radio Module.

The Digital Chassis:

- achieves the High Intensity Radiated Field (HIRF) protection, internal module interconnection, digital and management processor capacity and power supply distribution,
- provides the helicopter with the mechanical and electrical interfaces,
- provides the hardware support of the downloaded software's.

The Radio Module:

- achieves the Radio Frequency (RF) signal emission, the Radio Frequency (RF) signal reception and the Beat Frequency (BF) signal extraction.

C. Physical description

The AHV1600 Transceiver is a metallic housing in the form of a parallelepiped protected by a black polyurethane painting.

It is made of a chassis with a front panel equipped with:

- an identification label,
- an amendments label,
- a main connector,
- two coaxial connectors:
 - one receive connector "RX" (J1),
 - one transmit connector "TX" (J2).

34-42-61

Page 1
2009/06/25

The AHV1600 Transceiver has:

- a radio module (5),
- a digital chassis which has:
 - a digital management board (2),
 - a power supply stage (1),
 - a mother I/O stage (3),
 - a HIRF module (6),
 - a mechanical chassis (4).

All sockets are equipped with specials caps.

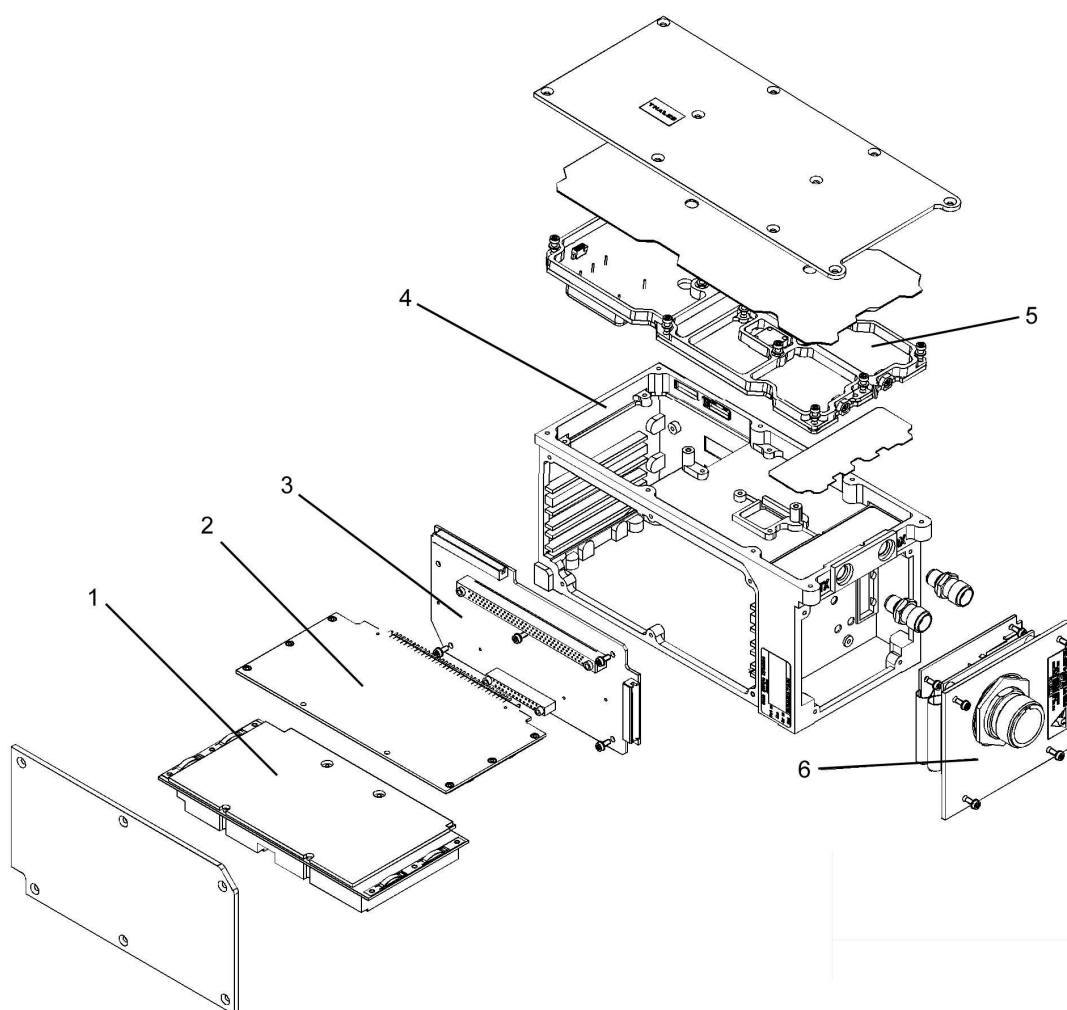

Figure 1 – AHV1600 Transceiver

GRAPHIC 34-42-61-991-001-A01

34-42-61

Page 2
2009/06/25

(1) Main connector

TABLE 34-42-61-992-018-A01

| CONTACT N° | SIGNAL NAME |
|------------|-------------|
| 1 | RA_EMIS_CMD |
| 2 | M_GND |
| 3 | TMS |
| 4 | CALIB_TEST |
| 5 | FCT_TST |
| 6 | TST_INH |
| 7 | CTZ_SEL2 |
| 8 | TCK |
| 9 | TX429_HI_1 |
| 10 | TX429_LO_1 |
| 11 | SPP1 |
| 12 | CTZ_SEL_P |
| 13 | TX429_HI_2 |
| 14 | RX429_LO_2 |
| 15 | MAINT |
| 16 | AID2 |
| 17 | P28V_1 |
| 18 | P28V_2 |
| 19 | RET28V_2 |
| 20 | AID_P |
| 21 | RS232_RX |
| 22 | RS232_TX |
| 23 | AID0 |
| 24 | AID1 |
| 25 | TDI |
| 26 | CTZ_SEL1 |
| 27 | TDO |

| CONTACT N° | SIGNAL NAME |
|------------|---------------|
| 28 | SEARCH_TRACK |
| 29 | EXTRAPOL_TEST |
| 30 | RET28V_1 |
| 31 | FB_TEST |
| 32 | VALDDS_TEST |
| 33 | E_GND |
| 34 | SDI_SEL |
| 35 | DDS_TEST |
| 36 | CTZ_1 |
| 37 | CTZ_2 |

(2) Identification

The identification label and the amendment label are stuck on the bottom of the transceiver.

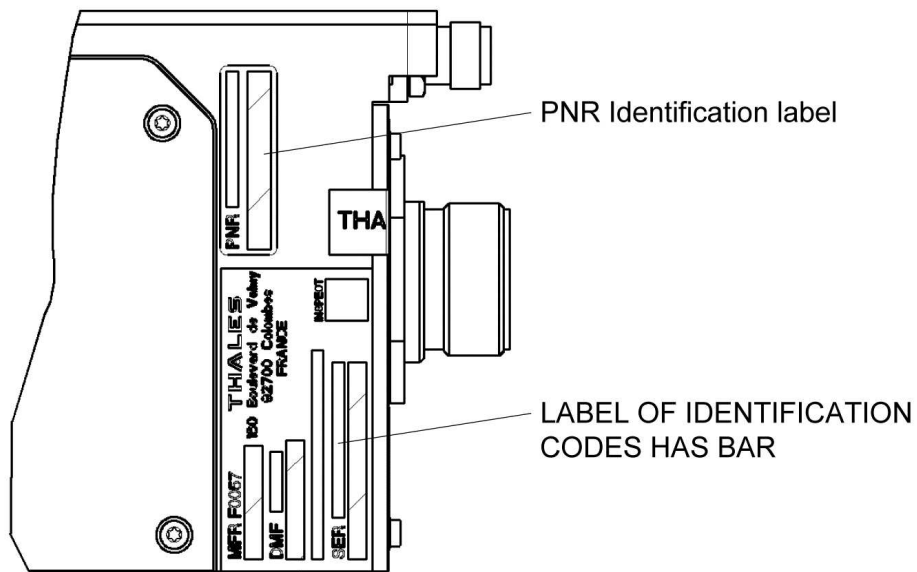

Figure 2 – Identification labels

GRAPHIC 34-42-61-991-002-A01

The specific label is stuck on the front panel.

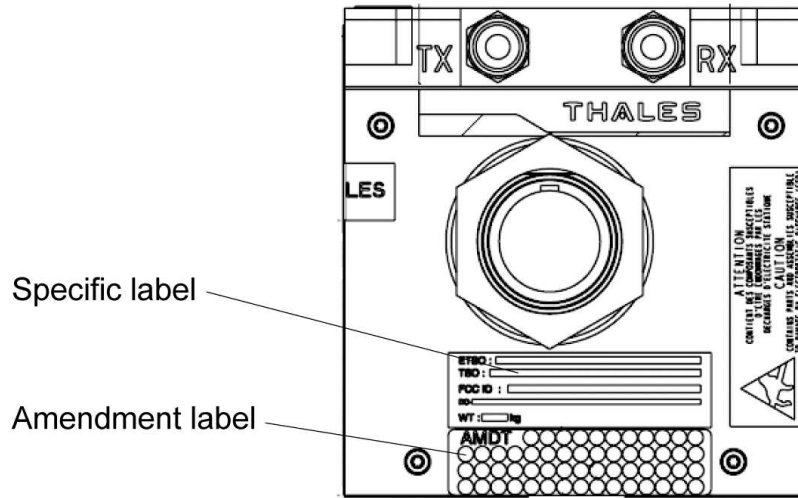

Figure 3 – Specific and amendment label

GRAPHIC 34-42-61-991-003-A01

The identification labels have the information that follows:

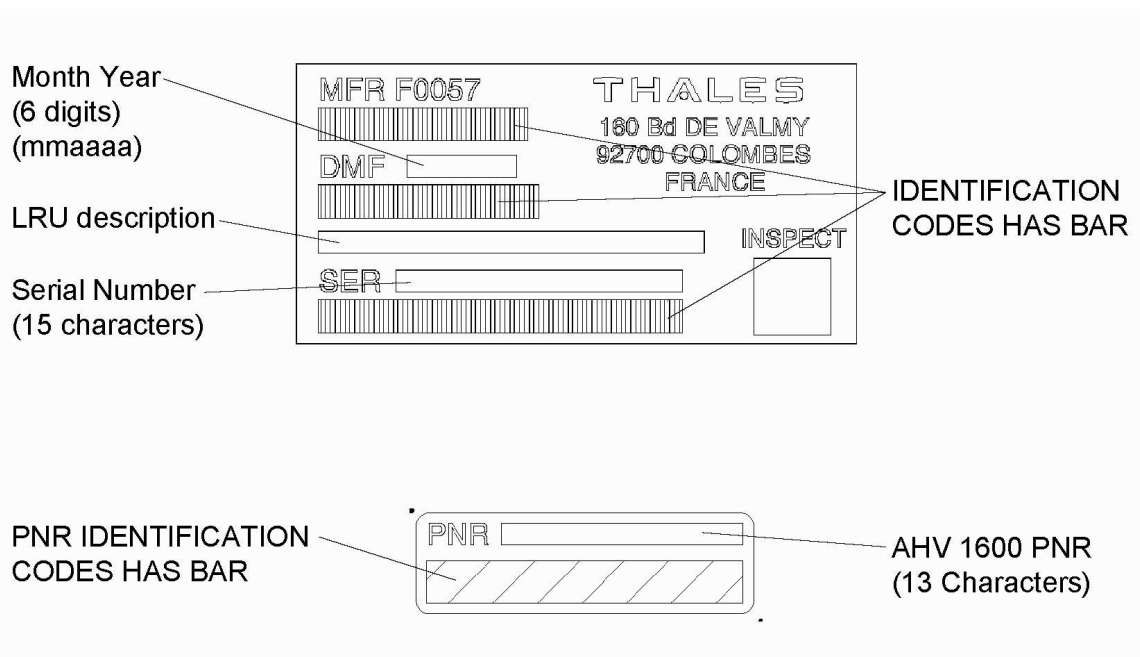

Figure 4 – Identification labels

GRAPHIC 34-42-61-991-004-A01

The amendment plate has the information that follows:

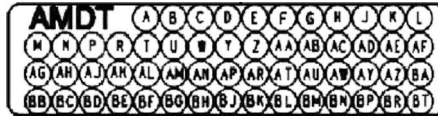

Figure 5 – Amendment label

GRAPHIC 34-42-61-991-005-A01

(3) Characteristics

(a) Physical characteristics

- Dimensions: 190 x 90 x 95 mm (7.48 x 3.54 x 3.74 in)
- Weight < 2 kg (4.4 lb)

(b) Functional characteristics

- Transmission: FM/CW
- Frequency range: 4.2 GHz to 4.4 GHz
- Frequency Deviation: 123 MHz typical
- Height accuracy: +/- [2 ft + 2%(h)] at 2 σ
- Transmitted Power: + 18 dBm max typical
- Power supply: 28 Vdc
- Power consumption: 20 W max (18 W typical)
- RS-232 maintenance line
- Interface: ARINC429 low speed

(4) Environmental conditions

(a) Vibration

- $0.01g^2/Hz$ over the frequency range: 20 Hz to 2 kHz, during 45 minutes per axis

(b) Shock

- Operational shock and crash safety: 6 g/11 ms ; 15 g/11 ms

(c) Temperature

- Operating temperature: - 40°C to + 70 °C (- 40 °F to + 158 °F)
- Power-up limited at: - 40°C (- 40°F)
- Ground survival high temperature: + 85°C (+ 185 °F)
- Ground survival low temperature: - 55°C (- 67 °F)
- Temperature variation: 5°C/min (9°F/min) (minimum)

(d) Humidity and water trickle

- Relative humidity: 95% with temperature of 50 °C (122 °F), during 48 hours
- (e) Electromagnetic environment compatibility

MIL-STD-461E:

- CE102
- CS101, CS114, CS116
- RE101, RE102
- RS101, RS103

TASK 34-42-61-870-802-A01

2. OPERATION

A. Functional architecture of the AHV1600

The general architecture of the AHV1600 is the following:

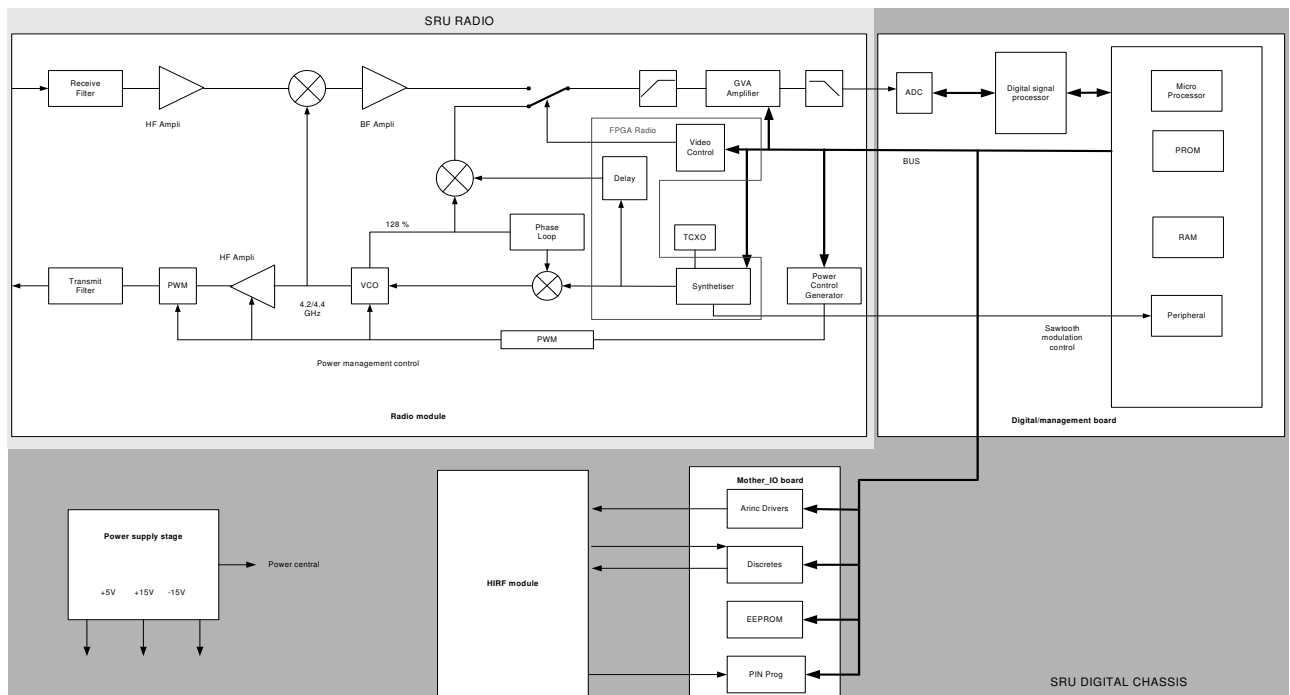

Figure 6 – General architecture of the AHV1600

GRAPHIC 34-42-61-991-006-A01

The AHV1600 transceiver has:

34-42-61

- Radio module: regroups the microwave transmitter and receiver, and the analog treatment of the beating frequency. The Digital Management board commands and monitors the radio module. It provides the Digital Management board with the beating frequency signal. It receives its power from the Power Supply (PS) stage. The Field Programmable Gate Array (FPGA) commands the radio module.
- Digital Management board: commands and monitors the transmission function of radio module and the height output function as well. It computes the height out of the beating frequency and the modulation shape of the effectively transmit frequency.
- Power Supply (PS) stage: provides the system with its needed power and Digital Management board with a status containing the results of power supply stage internal monitoring.
- Mother IO board: links the 4 other modules, the digital signals are adapted to their analog requirements and vice versa. It reads the discrete inputs and pin-programs status and communicates them to the Digital Management board. It also formats and sends the words on the height buses according to the information received from Digital Management functions.
- HIRF module: The HIRF part is not controlled (only passive components), protect the system from electromagnetic interferences and lightning.

B. Operation of the SRU Radio module

The SRU Radio module corresponds to the radio module controlled by a FPGA

(1) Radio module

The Radio module has the functions that follow:

- (a) Reception filter provides protection from interferences received through the antennas by the unit.
- (b) Transmission filters transmits the FM/CW (Frequency Modulated/Continuous Wave) signal.
- (c) Demodulation: it is a mixer that provides the AHV1600 transceiver with the BF (Beat Frequency) from the received RF (Radio Frequency) signal and a part of the transmit signal.
- (d) BF calibration is used during calibration. It filters and amplifies the BF signal.
- (e) BF filter determines the BF observation bandwidth of the AHV1600 transceiver.
- (f) GVA amplifier ("Gain Variable avec l'Altitude" variable gain with the height) is piloted by the management function according to the theoretically expected signal level at the current height. It is followed by an AGC (Automatic Gain Control) to adapt the signal level to the A/D (Analog to Digital) converter.
- (g) BF filter is the FM/CW digital synthesizer that feeds the PLL (Phase Lock Loop) in the MW (MicroWave). The digital synthesis is performed according to the commands received from the management function. An external Digital to Analog Converter followed by a filter is used to effectively pilot the MW calibration function of the PLL.

(h) BF calibration is the FM/CW digital synthesiser that feeds the PLL of transmitter function in the MW. The digital synthesis is performed according to the commands received from the management function. An external Digital to Analog Converter followed by a filter is used to effectively pilot's the transmitter function's PLL.

(2) FPGA

The radio module FPGA is the core of the radio module.

The FPGA functions are time independent: operations are begun and ended by a clock front to enable a fully deterministic time analysis.

To avoid interferences with the FPGA control function no programmable cell is used as a memory.

The figure that follows presents the relationships between the FPGA and the others function of the radio module.

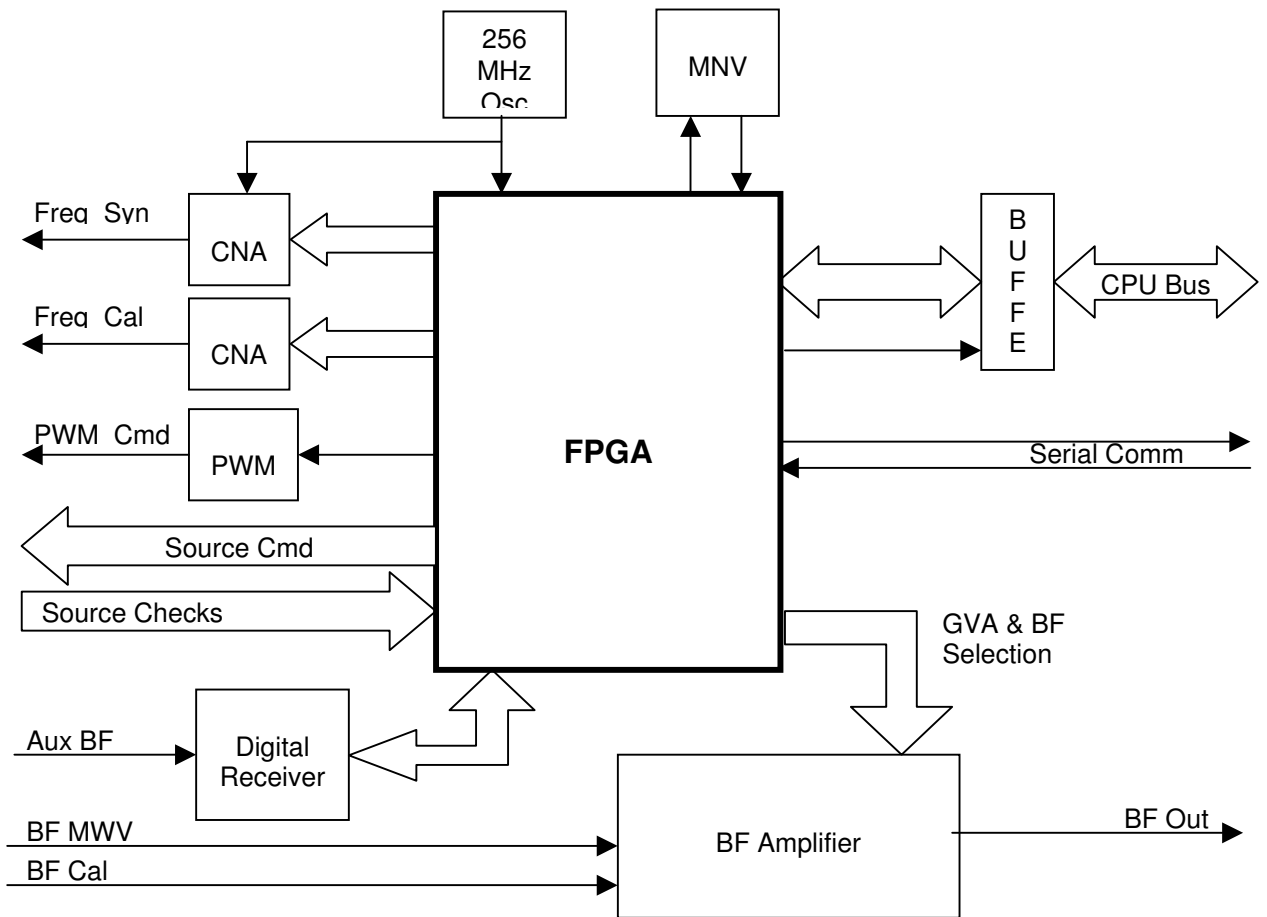

Figure 7 – General architecture of the FPGA

GRAPHIC 34-42-61-991-007-A01

The radio module FPGA has the functions that follow:

34-42-61

- Clock and Bus Control Unit allows the internal clock signals generation, the management of the both bidirectional buses, CPU bus and AD6620 bus.
- CPU decoding unit performs the addresses decoding for the registers accesses in read and write mode.
- FPGA Registers Unit contain all the internal registers and their various accesses.
- Debug and Monitoring Unit allows a stand alone control of the radio module by the mean of a terminal for debugging and set-up. When the radio module is controlled by the CPU, a monitoring mode is allowed.
- EEPROM Control Unit performs the NVM (Non Volatile Memory) control in read and write mode.
- Frequency Synthesis Unit includes:
 - Reference frequency Freq_Syn samples generation
 - Delayed frequency Freq_Cal samples generation
 - Sawtooth modulation control providing the logical signals reflecting the modulation duration and BF samples validation
 - Modulation duration computation
- Transmit and Receive Configuration Unit controls the transmission sequencing in the different modes, the signals to the microwave part.
- PWM Control Unit generates the Power Management voltage
- GVA Control Unit controls the GVA A/D convertor.

C. Operation of the SRU Digital chassis

The SRU Digital chassis has the modules that follow:

- Mechanical chassis,
- Mother I/O stage,
- HIRF module,
- Power Supply (PS) stage,
- Digital Management board.

(1) Mechanical chassis

It is the mechanical host of the AHV1600 transceiver.

(2) Mother I/O board

It has the functions that follow:

- Discrete inputs/outputs, pin programming
- Height buses.

- The I/O interface function reads the discrete inputs and pin-programs status and communicates them to the Digital Management board. It also formats and sends the words on the height buses according to the information received from Digital Management functions.

(3) HIRF module

It has the EMI (Electro Magnetic Interference) filter function.

The EMI filters protect the others modules, from all the specified EMI and especially vs. HIRF (High Intensity Radiated Field) and the indirect effects of lightning.

This module has only passive components.

(4) Power supply (PS) stage

It has the functions that follow:

- 28 V function: it is mainly an integrated converter, which supplies, on isolated wires, the other modules of the SRU with 5 V and 15 V voltage
- Power Supply control function: it controls the converter. The results of this monitoring are sent to the Digital Management board.

(5) Digital management board

It is the core of the AHV1600 transceiver and its processing channel.

It has one 68340 processor and one DSP 320C50 processor.

It has the functions that follow:

(a) Management function

It computes the height from the data received of the signal treatment function.

It realizes BIT (Built In Test) of the whole unit.

It manages the search/track stage of the AHV1600 transceiver.

It manages the operational/test/calibration modes of the AHV1600 transceiver.

It pilots the synthesiser and GVA (Gain variable with the height) functions.

(b) Signal treatment function

It performs the basic signal treatment on the BF samples, extracts from the obtained BF spectrum the relevant parameters and sends them to the management function.

It is mainly a software component embedded in DSP (Digital Signal Processor).

(c) A/D conversion function

It is an A/D converter. From the BF signal it obtains its samples and sends them to the signal treatment function.

THIS PAGE INTENTIONALLY LEFT BLANK

34-42-61

Page 12
2009/06/25