

# TEST REPORT

FCC ID: KA2WR932WB1

Product: 4G LTE AX300 Wi-Fi 6 MOBILE HOTSPOT

Model No.: DWR-932W, DWR-932W/X, DWR-932W/XX, DWR-932W/XXX (X CAN BE 0-9, A-Z)

Trade Mark: D-Link

Report No.: WSCT-ANAB-R&E250400022A-15B

Issued Date: 06 May 2025

Issued for:

D-Link Corporation

14420 Myford Road Suite 100, Irvine, California 92606, United States

Issued By:

World Standardization Certification & Testing Group(Shenzhen) Co.,Ltd.

Building A-B, Baoli'an Industrial Park, No. 58 Tangtou Avenue, Shiyan Street, Bao'an District, Shenzhen, Guangdong, China

TEL: +86-755-26996192

FAX: +86-755-86376605



**Note:** This report shall not be reproduced except in full, without the written approval of World Standardization Certification & Testing Group (Shenzhen) Co., Ltd. This document may be altered or revised by World Standardization Certification & Testing Group (Shenzhen) Co., Ltd. personnel only, and shall be noted in the revision section of the document. The test results in the report only apply to the tested sample.



## TABLE OF CONTENTS

<b>1. Test Certification</b> .....	<b>3</b>
<b>2. GENERAL DESCRIPTION OF EUT</b> .....	<b>4</b>
<b>3. Test Result Summary</b> .....	<b>5</b>
<b>4. TEST METHODOLOGY</b> .....	<b>6</b>
4.1. CONFIGURATION OF SYSTEM UNDER TEST .....	7
4.2. DESCRIPTION OF SUPPORT UNITS (CONDUCTED MODE) .....	8
<b>5. MEASUREMENT INSTRUMENTS</b> .....	<b>9</b>
<b>6. Facilities and Accreditations</b> .....	<b>10</b>
6.1. FACILITIES .....	10
6.2. ACCREDITATIONS .....	10
6.3. MEASUREMENT UNCERTAINTY .....	11
<b>7. EMC EMISSION TEST</b> .....	<b>12</b>
7.1. CONDUCTED EMISSION MEASUREMENT .....	12
7.2. TEST RESULTS .....	14
7.3. RADIATED EMISSION MEASUREMENT .....	16
<b>8. Test Setup Photographs</b> .....	<b>23</b>



Report No.: WSCT-ANAB-R&E250400022A-15B

# 1. Test Certification

**Product:** 4G LTE AX300 Wi-Fi 6 MOBILE HOTSPOT

**Model No.:** DWR-932W, DWR-932W/X, DWR-932W/XX, DWR-932W/XXX (X CAN BE 0-9, A-Z)

**Additional Model:** D-Link

**Applicant:** D-Link Corporation  
14420 Myford Road Suite 100, Irvine, California 92606, United States

**Manufacturer:** D-LINK CORPORATION  
14420 Myford Road Suite 100, Irvine, California 92606, United States

**Date of receipt:** 04 March 2025

**Date of Test:** 05 March 2025 to 10 April 2025

**Applicable Standards:** FCC CFR Title 47 Part 15 Subpart B

The above equipment has been tested by World Standardization Certification & Testing Group(Shenzhen) Co., Ltd. and found compliance with the requirements set forth in the technical standards mentioned above. The results of testing in this report apply only to the product system, which was tested. Other similar equipment will not necessarily produce the same results due to production tolerance and measurement uncertainties.

**Tested By:** Jiang Guanliang  
(Jiang Guanliang)

**Checked By:** Qin Shuiquan  
(Qin Shuiquan)

**Approved By:** Li Huaibi  
(Li Huaibi)

**Date:** 06 May 2025



Report No.: WSCT-ANAB-R&amp;E250400022A-15B

## 2. GENERAL DESCRIPTION OF EUT

<b>Product Name:</b>	4G LTE AX300 Wi-Fi 6 MOBILE HOTSPOT
<b>Model:</b>	DWR-932W, DWR-932W/X, DWR-932W/XX, DWR-932W/XXX (X CAN BE 0-9, A-Z)
<b>Trade Mark:</b>	D-Link
<b>Operating Voltage</b>	Rechargeable Li-ion Polymer Battery: 675465ART Rated Voltage: 3.7V Limited charge voltage:4.2V Rated Capacity: 3000mAh/11.1Wh
<b>Remark:</b>	N/A.

Note: 1. N/A stands for no applicable.

Report No.: WSCT-ANAB-R&E250400022A-15B

### 3. Test Result Summary

Requirement	CFR 47 Section	Result
CONDUCTED EMISSION	§15.107	PASS
RADIATED EMISSION	§15.109	PASS

**Note:**

1. PASS: Test item meets the requirement.
2. Fail: Test item does not meet the requirement.
3. N/A: Test case does not apply to the test object.
4. The test result judgment is decided by the limit of test standard.



Report No.: WSCT-ANAB-R&amp;E250400022A-15B

## 4. TEST METHODOLOGY

To investigate the maximum EMI emission characteristics generates from EUT, the test system was pre-scanning tested base on the consideration of following EUT operation mode or test configuration mode which possible have effect on EMI emission level. Each of these EUT operation mode(s) or test configuration mode(s) mentioned above was evaluated respectively.

Pretest Mode	Description
Mode 1	Video Recording
Model 2	Video Playing
Mode 3	Exchange data with computer
Mode 4	FM

Report No.: WSCT-ANAB-R&E250400022A-15B

### 4.1. CONFIGURATION OF SYSTEM UNDER TEST

Mode 1&2&4

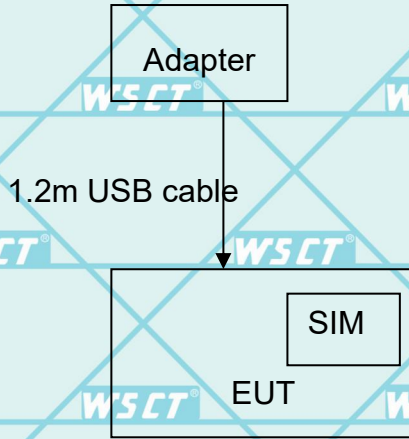

Mode 3:



(EUT: 4G LTE AX300 Wi-Fi 6 MOBILE HOTSPOT)

I/O Port of EUT			
I/O Port Type	Q'TY	Cable	Tested with
Power	1	1.5m USB cable, unshielded	1



Report No.: WSCT-ANAB-R&E250400022A-15B

## 4.2. DESCRIPTION OF SUPPORT UNITS (CONDUCTED MODE)

The EUT has been tested as an independent unit together with other necessary accessories or support units. The following support units or accessories were used to form a representative test configuration during the tests.

Item	Equipment	Mfr/Brand	Model/Type No.	Series No.	Note
1	Adapter	/	Adapter1/2	/	/
2	PC	Lenovo	TP00067A	PF-OGT3MS	/

Note:

- (1) The support equipment was authorized by Declaration of Confirmation.
- (2) For detachable type I/O cable should be specified the length in cm in 『Length』 column.
- (3) For multiple adapters, the report only displays the adapter with the worst data.



Report No.: WSCT-ANAB-R&E250400022A-15B

## 5. MEASUREMENT INSTRUMENTS

Kind of Equipment	Manufacturer	Type No.	Serial No.	Last Calibrated	Calibrated until
Test software	--	EZ-EMC	CON-03A	--	--
ESCI Test Receiver	R&S	ESCI	100005	11/05/2024	11/04/2025
LISN	AFJ	LS16	16010222119	11/05/2024	11/04/2025
LISN(EUT)	Mestec	AN3016	04/10040	11/05/2024	11/04/2025
pre-amplifier	CDSI	PAP-1G18-38	--	11/05/2024	11/04/2025
System Controller		SC100	-	11/05/2024	11/04/2025
Bi-log Antenna	Chase	CBL6111C	2576	11/05/2024	11/04/2025
Spectrum analyzer	R&S	FSU26	200409	11/05/2024	11/04/2025
Horn Antenna	SCHWARZBECK	9120D	11141	11/05/2024	11/04/2025
Bi-log Antenna	SCHWARZBECK	VULB9168	01488	7/29/2024	7/28/2025
Pre Amplifier	H.P.	HP8447E	2945A02715	11/05/2024	11/04/2025
9*6*6 Anechoic		--	--	11/05/2024	11/04/2025



Report No.: WSCT-ANAB-R&amp;E250400022A-15B

## 6. Facilities and Accreditations

### 6.1. Facilities

All measurement facilities used to collect the measurement data are located at **Building A-B, Baoli'an Industrial Park, No. 58 Tangtou Avenue, Shiyan Street, Bao'an District, Shenzhen, Guangdong, China of the World Standardization Certification & Testing Group(Shenzhen) Co.,Ltd.**

The sites are constructed in conformance with the requirements of ANSI C63.4 and CISPR Publication 22. All receiving equipment conforms to CISPR Publication 16-1, "Radio Interference Measuring Apparatus and Measurement Methods."

### 6.2. ACCREDITATIONS

#### ANAB - Certificate Number: AT-3951

The EMC Laboratory has been accredited by the American Association for Laboratory Accreditation (ANAB). Certification Number: AT-3951



Report No.: WSCT-ANAB-R&E250400022A-15B

### 6.3. Measurement Uncertainty

The reported uncertainty of measurement  $y \pm U$ , where expanded uncertainty  $U$  is based on a standard uncertainty multiplied by a coverage factor of  $k=2$ , providing a level of confidence of approximately 95 %.

No.	Item	MU
1	Conducted Emission Test	$\pm 3.2\text{dB}$
2	RF power, conducted	$\pm 0.16\text{dB}$
3	Spurious emissions, conducted	$\pm 0.21\text{dB}$
4	All emissions, radiated(<1GHz)	$\pm 4.7\text{dB}$
5	All emissions, radiated(>1GHz)	$\pm 4.7\text{dB}$
6	Temperature	$\pm 0.5^\circ\text{C}$
7	Humidity	$\pm 2.0\%$



Report No.: WSCT-ANAB-R&E250400022A-15B

## 7. EMC EMISSION TEST

### 7.1. CONDUCTED EMISSION MEASUREMENT

#### 7.1.1. POWER LINE CONDUCTED EMISSION LIMITS

FREQUENCY (MHz)	Class A (dBuV)		Class B (dBuV)		Standard
	Quasi-peak	Average	Quasi-peak	Average	
0.15 -0.5	79.00	66.00	66 - 56 *	56 - 46 *	FCC
0.50 -5.0	73.00	60.00	56.00	46.00	FCC
5.0 -30.0	73.00	60.00	60.00	50.00	FCC

Note:

- (1) The tighter limit applies at the band edges.
- (2) The limit of " \* " marked band means the limitation decreases linearly with the logarithm of the frequency in the range.

The following table is the setting of the receiver

Receiver Parameters	Setting
Attenuation	10 dB
Start Frequency	0.15 MHz
Stop Frequency	30 MHz
IF Bandwidth	9 kHz

Report No.: WSCT-ANAB-R&E250400022A-15B

**TEST PROCEDURE**

- a. The EUT was placed 0.4 meters from the horizontal ground plane with EUT being connected to the power mains through a line impedance stabilization network (LISN). All other support equipments powered from additional LISN(s). The LISN provide 50 Ohm/ 50uH of coupling impedance for the measuring instrument.
- b. Interconnecting cables that hang closer than 40 cm to the ground plane shall be folded back and forth in the center forming a bundle 30 to 40 cm long.
- c. I/O cables that are not connected to a peripheral shall be bundled in the center. The end of the cable may be terminated, if required, using the correct terminating impedance. The overall length shall not exceed 1 m.
- d. LISN at least 80 cm from nearest part of EUT chassis.
- e. For the actual test configuration, please refer to the related Item –EUT Test Photos.

**TEST SETUP**

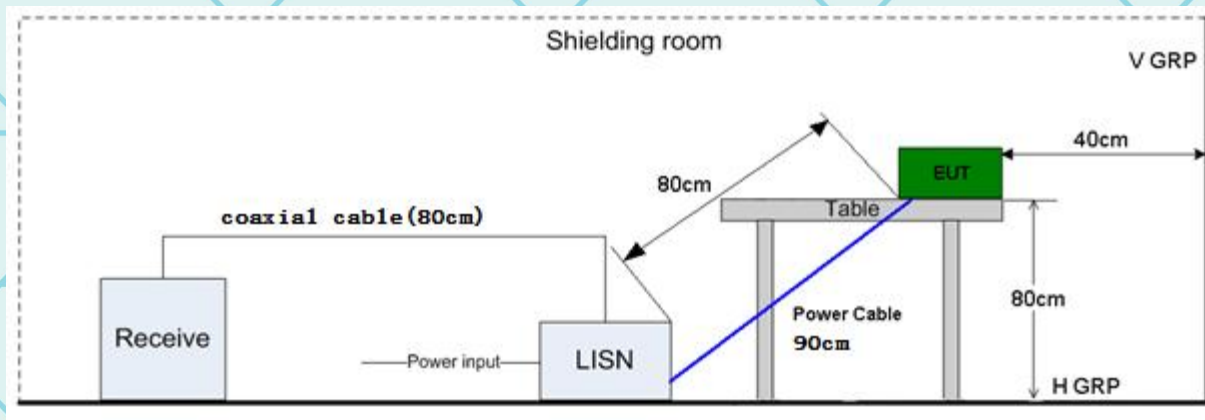

Report No.: WSCT-ANAB-R&E250400022A-15B

## 7.2. Test Results

Temperature	20 °C	Relative Humidity	48%
Pressure	1010 hPa	Test Mode	Mode 3(the worst case)

### Conducted Emission on Line Terminal of the power line (150 kHz to 30MHz)

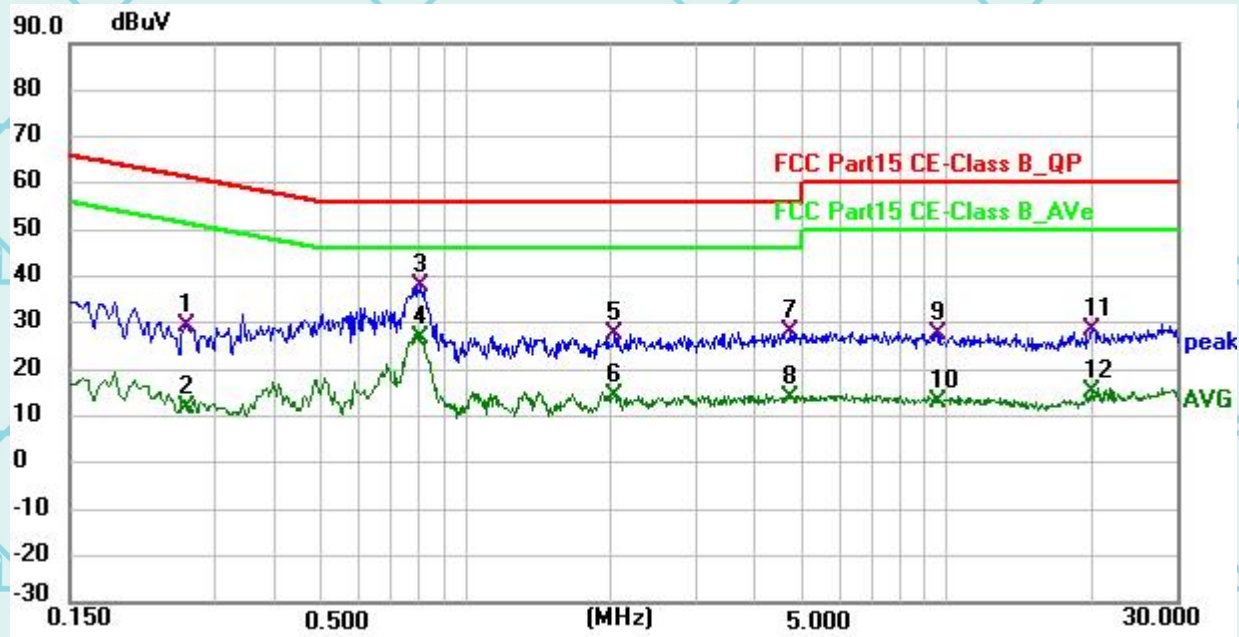

No.	Frequency (MHz)	Reading (dBuV)	Factor (dB)	Level (dBuV)	Limit (dBuV)	Margin (dB)	Detector
1	0.2625	8.68	20.65	29.33	61.35	-32.02	QP
2	0.2625	-8.69	20.65	11.96	51.35	-39.39	AVG
3 *	0.8070	17.25	20.59	37.84	56.00	-18.16	QP
4	0.8070	5.99	20.59	26.58	46.00	-19.42	AVG
5	2.0400	7.01	20.61	27.62	56.00	-28.38	QP
6	2.0400	-6.31	20.61	14.30	46.00	-31.70	AVG
7	4.6994	7.32	20.57	27.89	56.00	-28.11	QP
8	4.6994	-6.47	20.57	14.10	46.00	-31.90	AVG
9	9.5639	7.39	20.46	27.85	60.00	-32.15	QP
10	9.5639	-7.39	20.46	13.07	50.00	-36.93	AVG
11	20.0264	8.39	20.26	28.65	60.00	-31.35	QP
12	20.0264	-4.94	20.26	15.32	50.00	-34.68	AVG



Report No.: WSCT-ANAB-R&E250400022A-15B

**Conducted Emission on Neutral Terminal of the power line (150 kHz to 30MHz)**

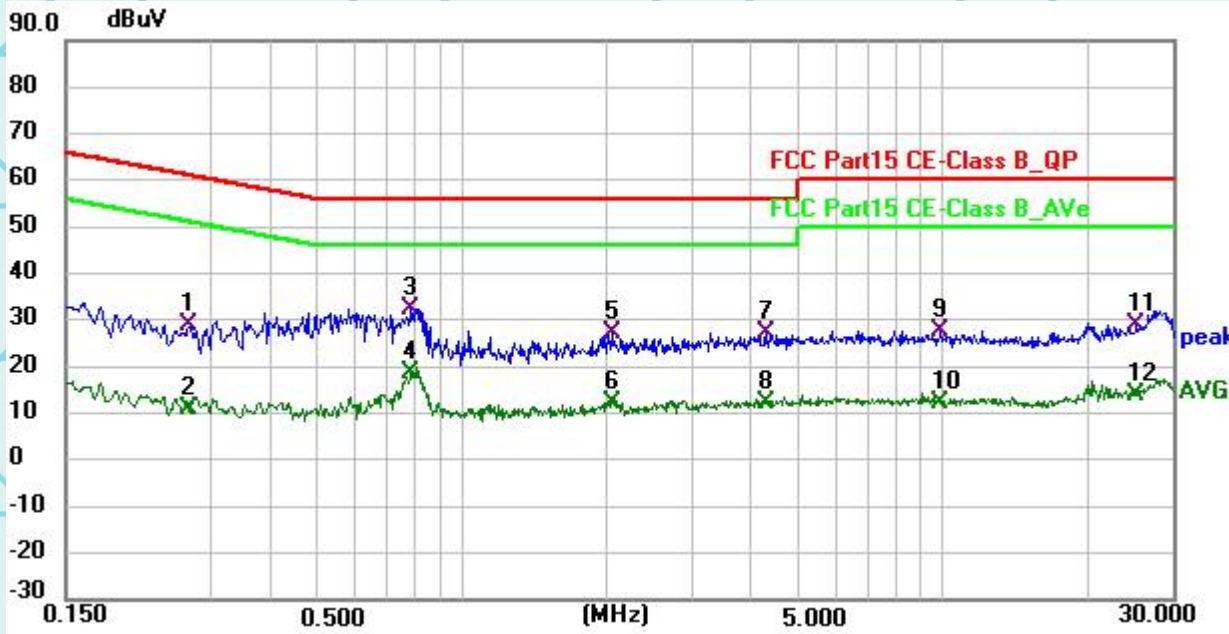

No.	Frequency (MHz)	Reading (dBuV)	Factor (dB)	Level (dBuV)	Limit (dBuV)	Margin (dB)	Detector
1	0.2714	8.39	20.65	29.04	61.07	-32.03	QP
2	0.2714	-9.71	20.65	10.94	51.07	-40.13	AVG
3 *	0.7845	11.78	20.58	32.36	56.00	-23.64	QP
4	0.7845	-2.00	20.58	18.58	46.00	-27.42	AVG
5	2.0490	6.71	20.61	27.32	56.00	-28.68	QP
6	2.0490	-8.42	20.61	12.19	46.00	-33.81	AVG
7	4.2720	6.51	20.58	27.09	56.00	-28.91	QP
8	4.2720	-8.49	20.58	12.09	46.00	-33.91	AVG
9	9.9060	7.03	20.45	27.48	60.00	-32.52	QP
10	9.9060	-8.30	20.45	12.15	50.00	-37.85	AVG
11	25.3185	8.24	20.64	28.88	60.00	-31.12	QP
12	25.3185	-6.64	20.64	14.00	50.00	-36.00	AVG

**Note1:**

Freq. = Emission frequency in MHz

Reading level (dBuV) = Receiver reading

Corr. Factor (dB) = LISN Factor + Cable loss

Measurement (dBuV) = Reading level (dBuV) + Corr. Factor (dB)

Limit (dBuV) = Limit stated in standard

Margin (dB) = Measurement (dBuV) – Limits (dBuV)

Q.P. =Quasi-Peak    AVG =average

\* is meaning the worst frequency has been tested in the frequency range 150 kHz to 30MHz.



### 7.3. RADIATED EMISSION MEASUREMENT

#### 7.3.1. Radiated Emission Limits

The field strength of radiated emissions from unintentional radiators at a distance of 3 meters shall not exceed the following values:

Frequencies (MHz)	Field Strength (microvolts/meter)	Measurement Distance (meters)
0.009~0.490	2400/F(KHz)	300
0.490~1.705	24000/F(KHz)	30
1.705~30.0	30	30
30~88	100	3
88~216	150	3
216~960	200	3
Above 960	500	3

#### LIMITS OF RADIATED EMISSION MEASUREMENT (Above 1000MHz)

FREQUENCY (MHz)	Limit (dBuV/m) (at 3M)	
	PEAK	AVERAGE
Above 1000	74	54

Notes:

- (1) The limit for radiated test was performed according to FCC PART 15B.
- (2) The tighter limit applies at the band edges.
- (3) Emission level (dBuV/m)=20log Emission level (uV/m).

Spectrum Parameter	Setting
Attenuation	Auto
Start Frequency	1000 MHz
Stop Frequency	10th carrier harmonic
RB / VB (emission in restricted band)	1 MHz / 1 MHz for Peak, 1 MHz / 1Hz for Average

Receiver Parameter	Setting
Attenuation	Auto
Start ~ Stop Frequency	9kHz~150kHz / RB 200Hz for QP
Start ~ Stop Frequency	150kHz~30MHz / RB 9kHz for QP
Start ~ Stop Frequency	30MHz~1000MHz / RB 120kHz for QP

Report No.: WSCT-ANAB-R&amp;E250400022A-15B

**TEST PROCEDURE**

- a. The measuring distance of at 3 m shall be used for measurements at frequency up to 1GHz. For frequencies above 1GHz, any suitable measuring distance may be used.
- b. The EUT was placed on the top of a rotating table 0.8 meters above the ground at a 3 meter open area test site. The table was rotated 360 degrees to determine the position of the highest radiation.
- c. The height of the equipment or of the substitution antenna shall be 0.8 m; the height of the test antenna shall vary between 1 m to 4 m. Both horizontal and vertical polarizations of the antenna are set to make the measurement.
- d. The initial step in collecting conducted emission data is a spectrum analyzer peak detector mode pre-scanning the measurement frequency range. Significant peaks are then marked and then Quasi Peak detector mode re-measured.
- e. If the Peak Mode measured value compliance with and lower than Quasi Peak Mode Limit, the EUT shall be deemed to meet QP Limits and then no additional QP Mode measurement performed.
- f. For the actual test configuration, please refer to the related Item –EUT Test Photos.

TEST SETUP

(A) Radiated Emission Test-Up Frequency 30MHz~1GHz

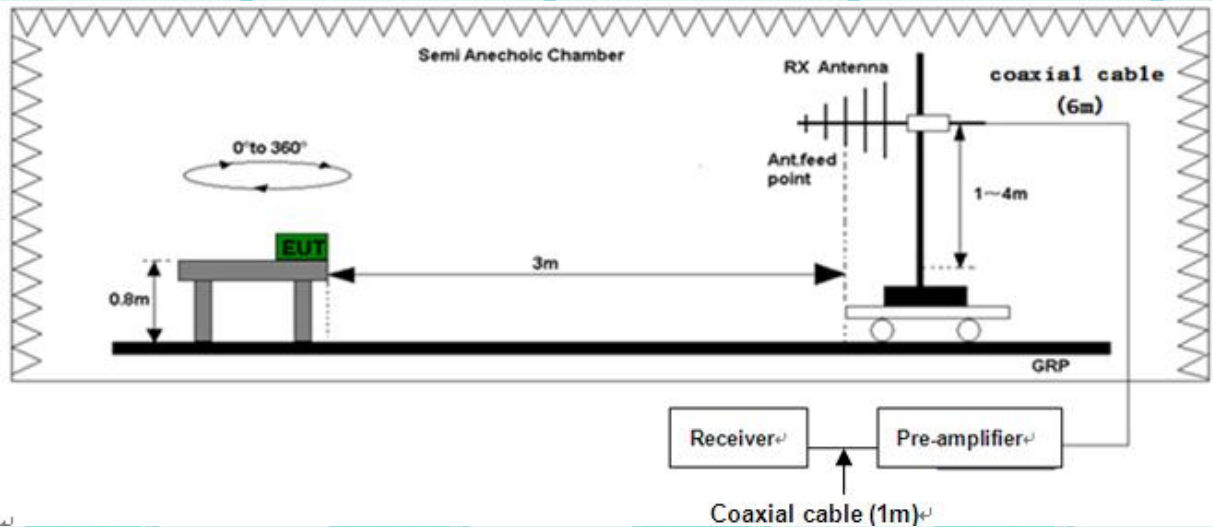

(B) Radiated Emission Test-Up Frequency Above 1GHz

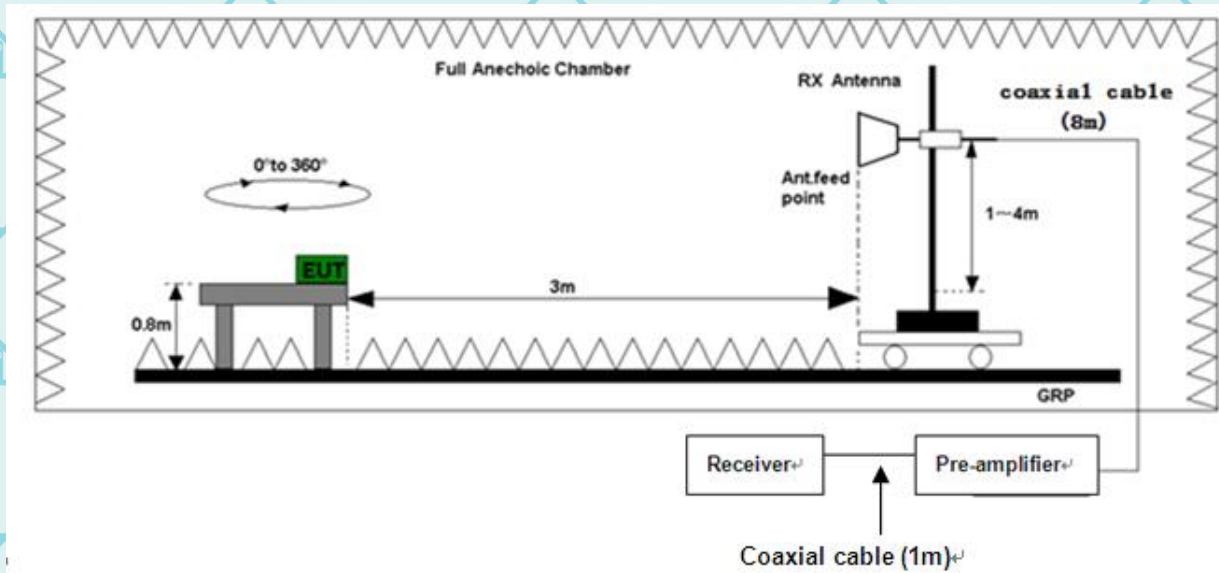

Report No.: WSCT-ANAB-R&E250400022A-15B

### 7.3.2. Test Results

Temperature	20 °C	Relative Humidity	48%
Pressure	1010 hPa	Test Mode	Mode 3(the worst case)

Please refer to following diagram for individual  
Below 1GHz

Horizontal:

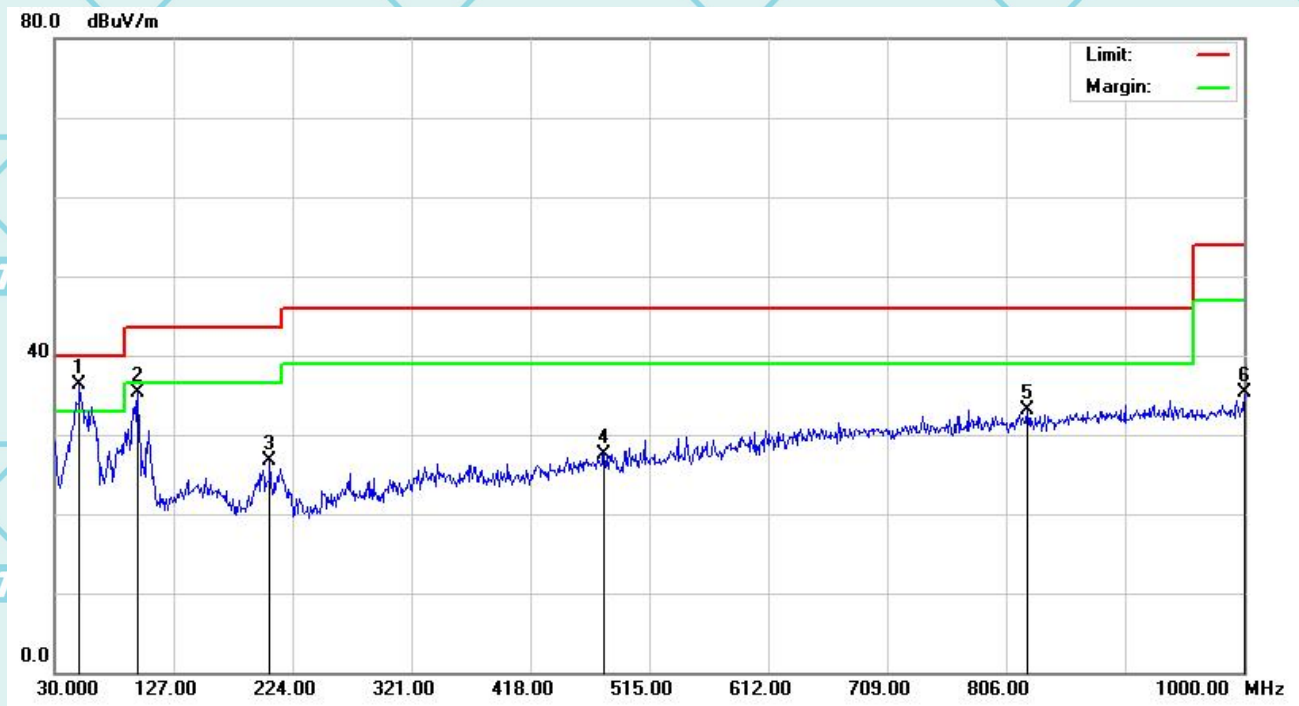

No.	Mk.	Freq. MHz	Reading Level dBuV	Correct Factor dB	Measure- ment dBuV/m	Limit dBuV/m	Over dB	Detector
1	*	50.3700	38.42	-2.14	36.28	40.00	-3.72	QP
2		97.9000	41.08	-5.68	35.40	43.50	-8.10	QP
3		205.5700	32.56	-5.83	26.73	43.50	-16.77	QP
4		478.1400	26.15	1.45	27.60	46.00	-18.40	QP
5		823.4600	26.69	6.45	33.14	46.00	-12.86	QP
6		1000.000	26.88	8.40	35.28	54.00	-18.72	QP



Report No.: WSCT-ANAB-R&E250400022A-15B

Vertical:

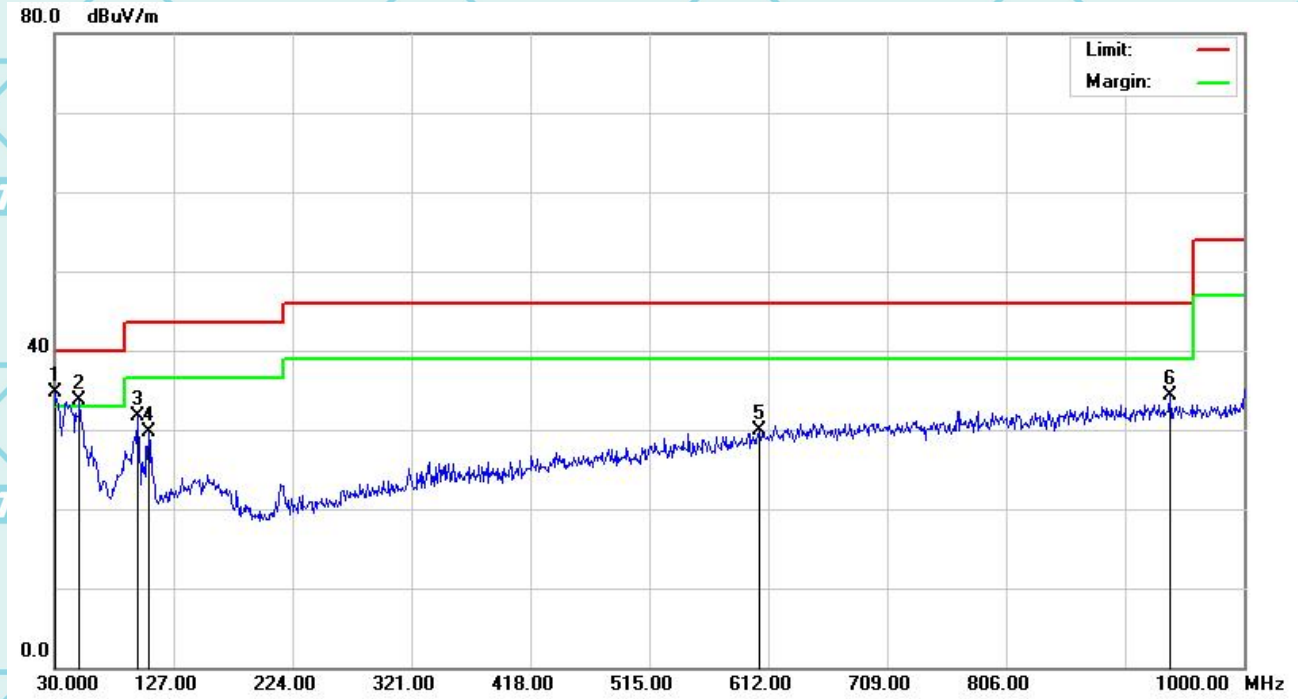

No.	Mk.	Freq. MHz	Reading Level dBuV	Correct Factor dB	Measure- ment dBuV/m	Limit dBuV/m	Over dB	Detector
1	*	30.0000	37.35	-2.60	34.75	40.00	-5.25	QP
2	!	50.3700	35.78	-2.14	33.64	40.00	-6.36	QP
3		97.9000	37.34	-5.68	31.66	43.50	-11.84	QP
4		106.6300	34.69	-4.90	29.79	43.50	-13.71	QP
5		605.2100	25.98	3.84	29.82	46.00	-16.18	QP
6		939.8600	26.13	8.08	34.21	46.00	-11.79	QP

Note1:

Freq. = Emission frequency in MHz

Reading level (dBuV) = Receiver reading

Corr. Factor (dB) = Antenna factor + Cable loss - Amplifier factor.

Measurement (dBuV) = Reading level (dBuV) + Corr. Factor (dB)

Limit (dBuV) = Limit stated in standard

Margin (dB) = Measurement (dBuV) - Limits (dBuV)



Report No.: WSCT-ANAB-R&E250400022A-15B

**TEST RESULTS**

Above 1GHz(1~6GHz) :( Mode 3—worst case)

Note: The spurious above 6G is noise only, do not show on the report.

Horizontal:

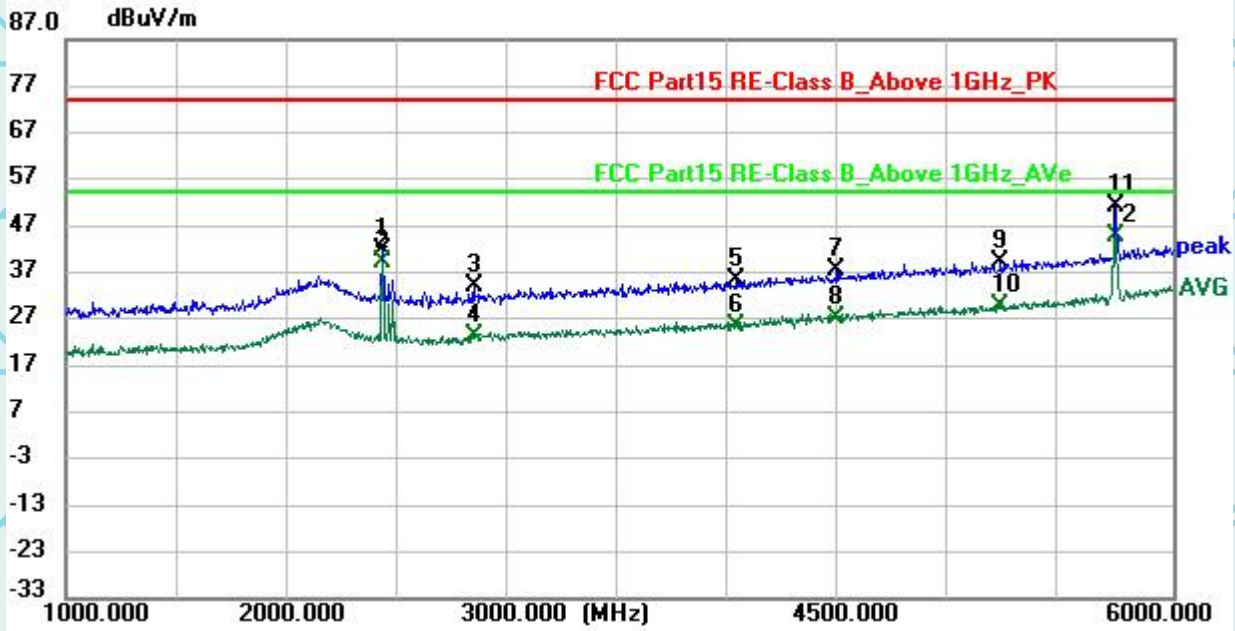

No.	Frequency (MHz)	Reading (dBuV)	Factor (dB/m)	Level (dBuV/m)	Limit (dBuV/m)	Margin (dB)	Detector
1	2435.000	45.84	-3.93	41.91	74.00	-32.09	peak
2	2435.000	43.19	-3.93	39.26	54.00	-14.74	AVG
3	2848.750	36.90	-2.68	34.22	74.00	-39.78	peak
4	2848.750	26.07	-2.68	23.39	54.00	-30.61	AVG
5	4033.750	34.43	1.13	35.56	74.00	-38.44	peak
6	4033.750	24.46	1.13	25.59	54.00	-28.41	AVG
7	4481.250	34.44	2.93	37.37	74.00	-36.63	peak
8	4481.250	24.47	2.93	27.40	54.00	-26.60	AVG
9	5221.875	33.14	5.97	39.11	74.00	-34.89	peak
10	5221.875	23.63	5.97	29.60	54.00	-24.40	AVG
11	5744.375	42.92	8.09	51.01	74.00	-22.99	peak
12 *	5744.375	36.75	8.09	44.84	54.00	-9.16	AVG



Report No.: WSCT-ANAB-R&E250400022A-15B

Vertical:

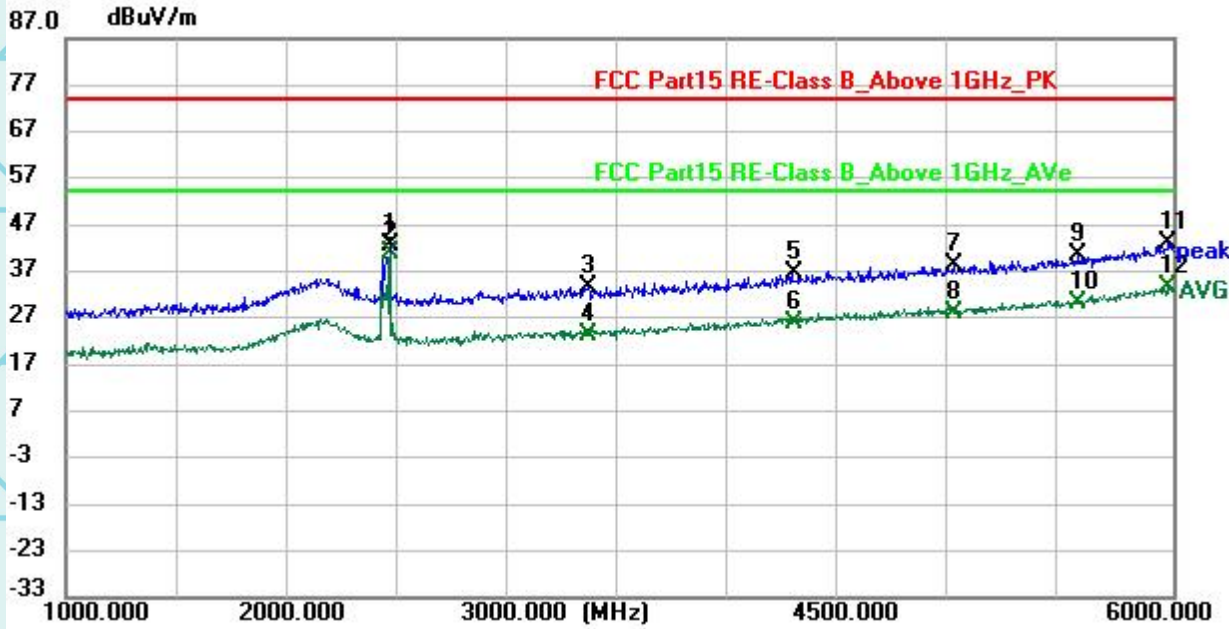

No.	Frequency (MHz)	Reading (dBuV)	Factor (dB/m)	Level (dBuV/m)	Limit (dBuV/m)	Margin (dB)	Detector
1	2468.125	46.60	-3.76	42.84	74.00	-31.16	peak
2 *	2468.125	44.76	-3.76	41.00	54.00	-13.00	AVG
3	3361.875	35.03	-1.44	33.59	74.00	-40.41	peak
4	3361.875	24.79	-1.44	23.35	54.00	-30.65	AVG
5	4286.250	34.30	2.13	36.43	74.00	-37.57	peak
6	4286.250	23.95	2.13	26.08	54.00	-27.92	AVG
7	5013.750	32.95	5.29	38.24	74.00	-35.76	peak
8	5013.750	22.96	5.29	28.25	54.00	-25.75	AVG
9	5580.000	33.49	7.22	40.71	74.00	-33.29	peak
10	5580.000	22.82	7.22	30.04	54.00	-23.96	AVG
11	5983.750	33.41	9.70	43.11	74.00	-30.89	peak
12	5983.750	23.90	9.70	33.60	54.00	-20.40	AVG

**Remark:**

All emissions not reported were more than 20dB below the specified limit or in the noise floor.

Freq. = Emission frequency in MHz

Factor = Antenna Factor + Cable Loss – Pre-amplifier.

Over= Emission Level - Limit.

All the x/y/z orientation has been investigated, and only worst case is presented in this report.



Report No.: WSCT-ANAB-R&E250400022A-15B

## 8. Test Setup Photographs

Please refer to Annex "Set Up Photos-15B" for test setup photos

**\*\*\*\*\*END OF REPORT\*\*\*\*\***

