



# RF TEST REPORT

Report No.: SZ25080340W03

**Applicant** : D-Link Corporation

**Product Name** : 4G LTE AX300 Wi-Fi 6 USB Adapter

**Brand Name** : D-LINK

**Model Name** : DWM-222W

**Series Model** : DWM-222W/x, DWM-222W/xx, DWM-222W/xxx  
(x can be 0-9 , A-Z)

**FCC ID** : KA2WM222WB1

**Test Standard** : 47 CFR Part 2, Part 24E, Part 22H

**Date of Sample Arrival** : 2025.07.21

**Date of Test** : 2025.07.21-2025.08.10

**Issue Date** : 2025.08.14

Edited by:

Zeng Xiaoying (Rapporteur)

Approved by:

Shen Junsheng (Supervisor)

**NOTE:** This document is issued by ShenzhenMorlab Communications Technology Co., Ltd., the test report shall not be reproduced except in full without prior written permission of the company. The test results apply only to the particular sample(s) tested and to the specific tests carried out which is available on request for validation and information confirmed at our website.



ShenzhenMorlab Communications Technology Co., Ltd.  
FL.1-3, Building A, FeiYang Science Park, No.8 LongChang Road,  
Block67, BaoAn District, ShenZhen, Guangdong Province, P. R. China

Tel: 86-755-36698555

Http://www.morlab.cn

Fax: 86-755-36698525

E-mail: service@morlab.cn



---

**TABLE OF CONTENTS**

REVISION HISTORY .....	3
DECLARATION OF REPORT .....	4
1. GENERAL DESCRIPTION .....	5
1.1. Applicant .....	5
1.2. Manufacturer .....	5
1.3. Factory .....	5
1.4. General Information of EUT .....	6
1.5. Equipment Specification .....	7
1.6. Environmental conditions .....	7
1.7. Modification of EUT .....	7
1.8. Laboratory Information .....	7
1.9. Applicable Standards .....	8
2. TEST CONFIGURATION OF EQUIPMENT UNDER TEST .....	8
2.1. Test Mode .....	8
2.2. Summary of Test Results .....	9
2.3. Connection Diagram of Test System .....	10
2.4. Support Unit used in test configuration and system .....	10
2.5. Equipment List .....	11
2.6. Measurement Uncertainty .....	13
3. TEST RESULT .....	14
3.1. Conducted Output Power .....	14
3.2. Effective Radiated Power and Effective Isotropic Radiated Power .....	15
3.3. Peak-to-Average Ratio .....	17
3.4. Occupied Bandwidth .....	18
3.5. Conducted Band Edge .....	20
3.6. Conducted Spurious Emission .....	22
3.7. Frequency Stability .....	23
3.8. Radiated Spurious Emission .....	24
4. TEST SETUP PHOTOGRAPHS .....	62
5. EXTERNAL AND INTERNAL PHOTOS OF THE EUT .....	62

---

**REVISION HISTORY**

<b>Rev.</b>	<b>Issue Date</b>	<b>Revisions</b>	<b>Revised by</b>
00	2025.08.14	Initial Release	Guozheng Li

## DECLARATION OF REPORT

1. The device has been tested by ATBL, and the test results show that the equipment under test (EUT) is in compliance with the requirements of 47 CFR Part 2, Part 24E, Part 22H. And it is applicable only to the tested sample identified in the report.

2. This report shall not be reproduced except in full, without the written approval of ATBL, this document only be altered or revised by ATBL, personal only, and shall be noted in the revision of the document.

3. The general information of EUT in this report is provided by the customer or manufacture, ATBL is only responsible for the test data but not for the information provided by the customer or manufacture.

4. The results in this report is only apply to the sample as tested under conditions. The customer or manufacturer is responsible for ensuring that the additional production units of this model have the same electrical and mechanical components.

## 1. GENERAL DESCRIPTION

### 1.1. Applicant

Name : D-Link Corporation

Address : 14420 Myford Road Suite 100, Irvine, California 92606, United States

### 1.2. Manufacturer

Name : D-Link Corporation

Address : 14420 Myford Road Suite 100, Irvine, California 92606, United States

### 1.3. Factory

Name : AMIT Wireless Inc.

Address : No. 82, Gongye 2nd Rd., Annan Dist., Tainan City 709015, Taiwan, China

#### 1.4. General Information of EUT

Product Designation:	4G LTE AX300 Wi-Fi 6 USB Adapter
Brand Name	D-LINK
Model Name	DWM-222W
Series Model	DWM-222W/x, DWM-222W/xx, DWM-222W/xxx (x can be 0-9 , A-Z)
Model Difference	Only model name and color are different
Hardware Version:	B1
Software Version:	1.00.09LA
Support Networks:	WCDMA, HSDPA, HSUPA
Frequency Bands:	<input checked="" type="checkbox"/> UMTS FDD Band II <input checked="" type="checkbox"/> UMTS FDD Band IV <input checked="" type="checkbox"/> UMTS FDD Band V (U.S. Bands) <input type="checkbox"/> UMTS FDD Band I <input type="checkbox"/> UMTS FDD Band VIII (Non-U.S. Bands)
Type of Modulation:	BPSK,QPSK Modulation For WCDMA/HSDPA/HSUPA
Frequency Range:	WCDMA Band II: 1852.4MHz-1907.6 MHz
	WCDMA Band IV: 1710MHz-1755MHz
	WCDMA Band V: 826.4-846.6 MHz
Emission Designator:	WCDMA Band II:4M20F9W WCDMA Band IV:4M23F9W WCDMA Band V:4M18F9W
Antenna Type:	FPC Antenna
Antenna gain:	WCDMA Band II:2.15dBi WCDMA Band IV:1.38dBi WCDMA Band V:2.23dBi
Power Supply:	Input:DC 5V
Adapter:	/
Battery parameter:	/
SIM Card Description:	The sample machine supports a single card
Connecting I/O Port(s)	Refer to the remark below.

Remark:

The above information of EUT was declared by manufacturer. Please refer to the specifications or user's manual for more detailed description.

### 1.5. Equipment Specification

Maximum Output Power to Antenna	
Band	Maximum Output Power
<input checked="" type="checkbox"/> Band 2	27.54dBm
<input checked="" type="checkbox"/> Band 4	26.6dBm
<input checked="" type="checkbox"/> Band 5	23.7dBm
Type of Modulation	
<input checked="" type="checkbox"/> WCDMA <input checked="" type="checkbox"/> HSUPA <input checked="" type="checkbox"/> HSDPA	

### 1.6. Environmental conditions

Temperature	Normal Temperature(NT):	25°C
	High Temperature(HT):	45°C
	Low Temperature(LT):	0°C
Voltage	Normal Voltage(NV):	5V
	High Voltage(HV):	5.5V
	Low Voltage(LV):	4.5V
Other	Relative Humidity	55 %
	Air Pressure	101 kPa

### 1.7. Modification of EUT

No modifications are made to the EUT during all test items.

### 1.8. Laboratory Information

#### 1.8.1 Identification of the Responsible Testing Laboratory

<b>Laboratory Name:</b>	Shenzhen Morlab Communications Technology Co., Ltd.
<b>Laboratory Address:</b>	FL.1-3, Building A, FeiYang Science Park, No.8 LongChang Road, Block 67, BaoAn District, ShenZhen, GuangDong Province, P. R. China
<b>Telephone:</b>	+86 755 36698555
<b>Facsimile:</b>	+86 755 36698525

#### 1.8.2 Identification of the Responsible Testing Location

<b>Name:</b>	Shenzhen Morlab Communications Technology Co., Ltd.
<b>Address:</b>	FL.1-3, Building A, FeiYang Science Park, No.8 LongChang Road, Block 67, BaoAn District, ShenZhen, GuangDong Province, P. R. China

## 1.9. Applicable Standards

According to the specifications of the manufacturer, the EUT must comply with the requirements of the following standards:

47 CFR Part 2, 22(H), 24(E)

ANSI C63.26-2015

FCC KDB 971168 D01 Power Meas License Digital Systems v03r01

Remark:

All test items were verified and recorded according to the standards and without any deviation during the test.

## 2. TEST CONFIGURATION OF EQUIPMENT UNDER TEST

### 2.1. Test Mode

Band	Tx/Rx Frequency	RF Channel		
		Low(L)	Middle(M)	High(H)
WCDMA band V	TX (824 MHz ~ 849 MHz)	Channel 4132	Channel 4182	Channel 4233
		826.4 MHz	836.4 MHz	846.6 MHz

Band	Tx/Rx Frequency	RF Channel		
		Low(L)	Middle(M)	High(H)
WCDMA Band II	TX (1850 MHz-1910 MHz)	Channel 9262	Channel 9400	Channel 9538
		1852.4 MHz	1880.0 MHz	1907.6 MHz

Band	Tx/Rx Frequency	RF Channel		
		Low(L)	Middle(M)	High(H)
WCDMA Band IV	TX (1710 MHz-1755 MHz)	Channel 1312	Channel 1412	Channel 1513
		1712.4 MHz	1732.4 MHz	1752.6 MHz

Pre-scan all bandwidth and RB, find worse case mode are chosen to the report, the worse mode applicability and tested channel detail as below:

Band	Radiated	Conducted
WCDMA Band II/V/IV	RMC 12.2kbps Link	RMC 12.2kbps Link

The device supports MPR to solve linearity issues (ACLR or SEM) due to the higher peak-to average ratios (PAR) of the HSUPA signal. This prevents saturating the full range of the TX DAC inside of device and provides a reduced power output to the RF transceiver chip according to the Cubic Metric (a function of the combinations of DPDCH, DPCCH, HS-DPCCH, E-DPDCH and E-DPCCH).

When E-DPDCH channels are present the beta gains on those channels are reduced firsts to try to get the power under the allowed limit. If the beta gains are lowered as far as possible, then a hard limiting is applied at the maximum allowed level.

The SW currently recalculates the cubic metric every time the beta gains on the E-DPDCH are reduced. The cubic metric will likely get lower each time this is done .However, there is no reported reduction of maximum output power in the HSUPA mode since the device also provides a compensate for the power back-off by increasing the gain of TX\_AGC in the transceiver (PA) device.

The end effect is that the DUT output power is identical to the case where there is no MPR in the device.

## 2.2. Summary of Test Results

Conducted Test:

Item	Test Description	FCC Rules	Result
1	Occupied Bandwidth	§2.1049	Pass
2	Band Edge / Spurious and Harmonic Emissions at Antenna Terminal	§2.1051, §22.917(a), §24.238(a)	Pass
5	Conducted Output Power	§2.1046	Pass
6	Frequency stability / variation of ambient temperature	§2.1055, § 22.355, §24.235	Pass
7	Peak- to- Average Ratio	§24.232(d)	Pass

Radiated Test:

Item	Test Description	FCC Rules	Result
1	Effective Radiated Power	§22.913(a)(5)	Pass
2	Equivalent Isotropic Radiated Power	§24.232(c)	Pass
3	Radiated Spurious and Harmonic Emissions	§2.1053, §22.917(a), §24.238(a),	Pass

### 2.3. Connection Diagram of Test System

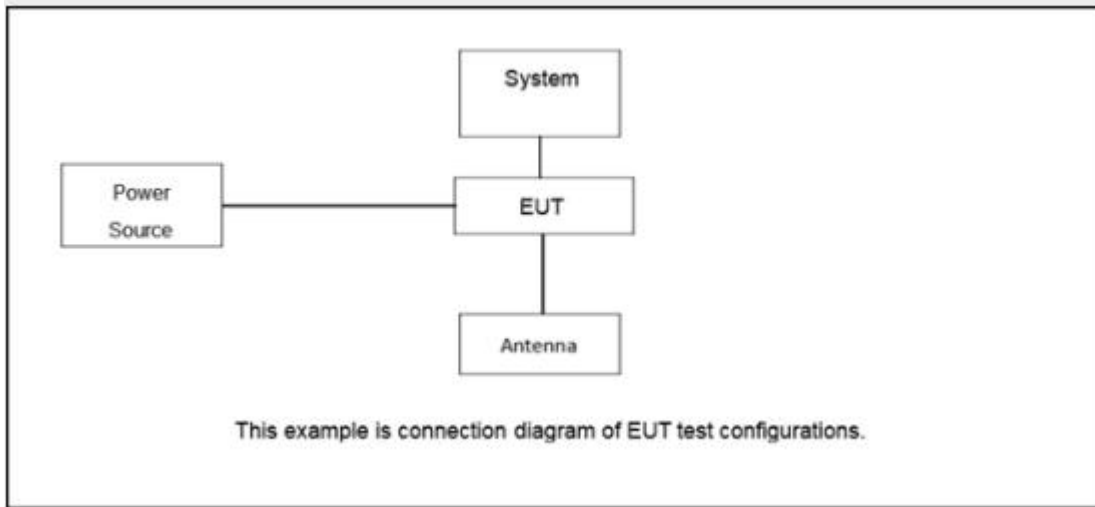

### 2.4. Support Unit used in test configuration and system

NO.	Unit	Brand	Model	Description
1	-	-	-	-
2	-	-	-	-
	-	-	-	-
	-	-	-	-
	-	-	-	-

## 2.5. Equipment List

### 2.5.1. For Conducted Test

Kind of Equipment	Manufacturer	Type No.	Serial No.	equipment number	Calibrated until	Calibrated due until	Cal. Interval
Environmental Test Chamber	BST	BST-HZ-410	T1131	SHATBL-W041	2025.03.17	2026.03.16	1 year
Vector signal generator	Agilent	N5182A	MY50143555	SHATBL-W037	2025.07.18	2026.07.17	1 year
Analog signal generator	Keysight	N5173B	MY60403026	SHATBL-W038	2025.07.18	2026.07.17	1 year
Wideband radio communication tester	R&S	CMW500	101331	SHATBL-W044	2025.07.28	2026.07.27	1 year
Spectrum analyzer	R&S	FSV40-N	101761	SHATBL-W036	2025.07.28	2026.07.27	1 year
Switch Box	MaiWei	MW200-RFCB	MW220720ATBL	SHATBL-W039	N/A	N/A	N/A
Thermometer	DeLi	N/A	N/A	SHATBL-W012	2025.08.01	2026.07.31	1 year
Test Software	MaiWei	MW-Test	N/A	N/A	N/A	N/A	N/A
band rejection filter	MaiWei	MW200-SFCB	MW220719ATBL	SHATBL-W040	2025.07.18	2026.07.17	1 year

**2.5.2. For Radiated Spurious Emission**

Kind of Equipment	Manufacturer	Type No.	Serial No.	equipment number	Calibrated until	Calibrated due until	Cal. Interval
Signal analyzer	Agilent	N9020A	MY50200811	SHATBL-E017	2025.03.17	2026.03.16	1 year
Amplifier	JPT	JPA0118-55-303A	1910001800055000	SHATBL-E006	2025.03.24	2026.03.23	1 year
Amplifier	JPT	JPA-10M1G32	21010100035001	SHATBL-E005	2025.03.17	2026.03.16	1 year
Antenna/Turntable Controller	Brilliant	N/A	N/A	SHATBL-E007	N/A	N/A	N/A
Loop Antenna(9kHz-30 MHz)	Daze	ZN30900C	20077	SHATBL-E042	2025.05.13	2026.05.12	1 year
Bilog Antenna	SCHWARZBECK	VULB 9168	01174	SHATBL-E008	2025.05.20	2026.05.19	1 year
Broad-band Horn Antenna	SCHWARZBECK	BBHA 9120D	02334	SHATBL-E009	2025.05.20	2026.05.19	1 year
Horn Antenna	COM-POWER	AH-1840	10100008	SHATBL-E043	2025.07.27	2026.07.26	1 year
Thermometer	DeLi	N/A	N/A	SHATBL-E015	2025.08.01	2026.07.31	1 year
Test Software	FALA	EMC-RI(Ver.4A2)	N/A	N/A	N/A	N/A	N/A
Wideband radio communication tester	R&S	CMW500	101331	SHATBL-W044	2025.07.28	2026.07.27	1 year
Spectrum analyzer	R&S	FSV40-N	101761	SHATBL-W036	2025.07.28	2026.07.27	1 year
Bilog Antenna (Substitute antenna)	SCHWARZBECK	VULB 9168	12258719	SHATBL-E045	2025.05.20	2026.05.19	1 year
Broad-band Horn Antenna (Substitute antenna)	SCHWARZBECK	BBHA 9120D	587756	SHATBL-E046	2025.05.20	2026.05.19	1 year

## 2.6. Measurement Uncertainty

The reported uncertainty of measurement  $y \pm U$ , where expanded uncertainty  $U$  is based on a standard uncertainty multiplied by a coverage factor of  $k=2$ , providing a level of confidence of approximately 95 %.

No.	Item	Uncertainty
1	Occupied Channel Bandwidth	$\pm 4\%$
2	Transmitter power conducted	$\pm 0.56$ dB
3	Transmitter power Radiated	$\pm 2.20$ dB
4	Conducted spurious emission	$\pm 1.60$ dB
5	Radiated spurious emission	$\pm 2.20$ dB
6	Temperature	$\pm 0.6^\circ\text{C}$
7	Humidity	$\pm 2\%$
8	DC and low frequency voltages	$\pm 0.05\%$
9	Radio frequency error	$\pm 3 \times 10^{-8}$

### 3. TEST RESULT

#### 3.1. Conducted Output Power

##### 3.1.1. Test Setup

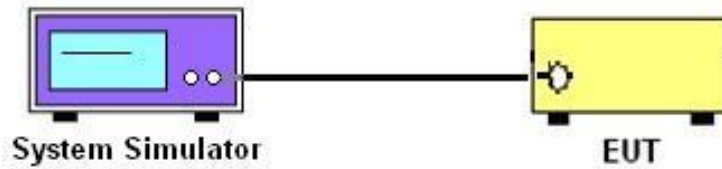

##### 3.1.2. Test Procedures

1. The testing follows ANSI C63.26 Section 5.2.
2. The transmitter output port was connected to the system simulator.
3. Set EUT at maximum power through the system simulator.
4. Select lowest, middle, and highest channels for each band and different modulation.
5. Measure and record the power level from the system simulator.

##### 3.1.3. Test Result

Please refer to the Appendix B1.

### 3.2. Effective Radiated Power and Effective Isotropic Radiated Power

#### 3.2.1. Test Limit

The substitution method, in ANSI/TIA-603-E-2016, was used for ERP/EIRP measurement, and the spectrum analyzer configuration follows KDB 971168 D01 Power Meas. License Digital Systems v03. The ERP of mobile transmitters must not exceed 7 Watts (Cellular Band) and the EIRP of mobile transmitters are limited to 2 Watts (PCS Band).

#### 3.2.2. Test Setup

Test site-up for radiated ERP and/or EIRP measurements

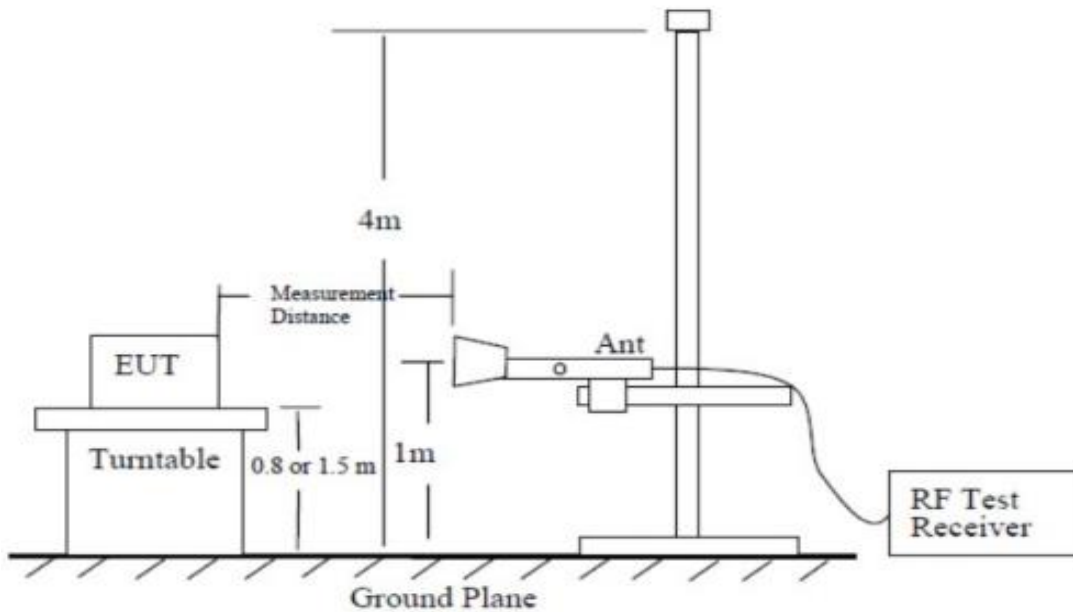

Substitution method set-up for radiated emission

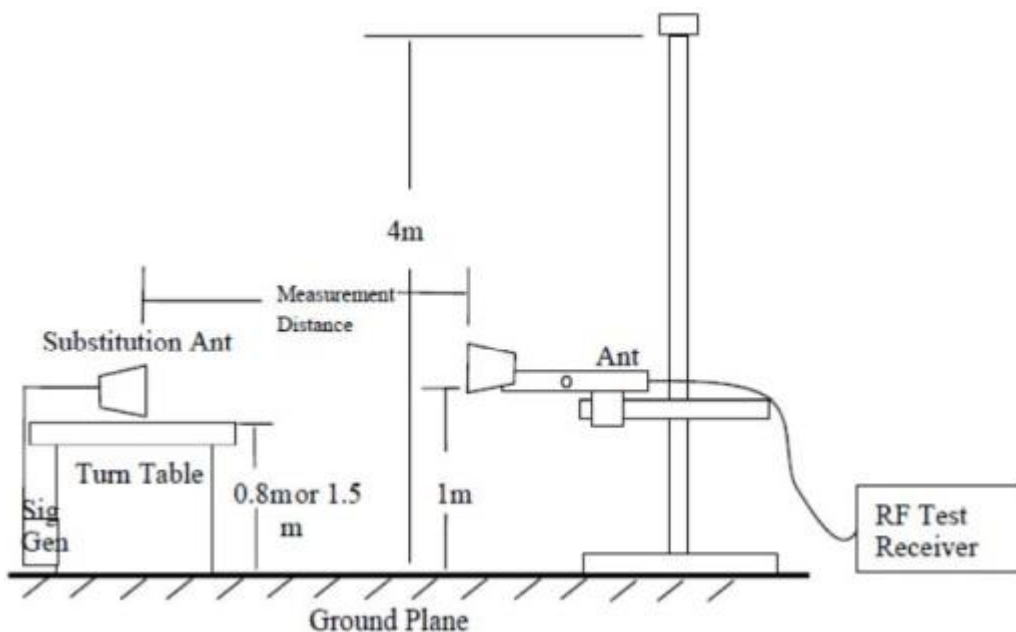

### 3.2.3. Test Procedures

1.The measurements procedures specified in ANSI/TIA-603-E-2016 were applied.

In an anechoic antenna test chamber, a half-wave dipole antenna for the frequency band of interest is placed at the reference centre of the chamber. An RF Signal source for the frequency band of interest is connected to the dipole with a cable that has been constructed to not interfere with the radiation pattern of the antenna. A known (measured) power ( $P_{in}$ ) is applied to the input of the dipole, and the power received ( $P_r$ ) at the chamber's probe antenna is recorded.

2.The relevant equation for determining the ERP or EIRP from the conducted RF output power measured using the guidance provided above is:

$$ERP/EIRP = SGLevel - P_{cl} + G_a$$

where:

ERP/EIRP = effective or equivalent radiated power, respectively (expressed in the same units as SGLevel, typically dBW or dBm);

SGLevel = Signal generator output power or PSD, in dBm or dBW;

$G_a$  = gain of the transmitting antenna, in dBd (ERP) or dBi (EIRP);

$P_{cl}$  = signal attenuation in the connecting cable between the transmitter and antenna.

The EUT is substituted for the dipole at the reference centre of the chamber and a scan is performed to obtain the radiation pattern.

From the radiation pattern, the co-ordinates where the maximum antenna gain occurs are identified.

3.The EUT is then put into continuously transmitting mode at its maximum power level. Power mode measurements are performed with the receiving antenna placed at the coordinates determined in Step 3 to determine the output power as defined in Rule 24.232 (b) and (c). The "reference path loss" from Step1 is added to this result.

This value is EIRP since the measurement is calibrated using a half-wave dipole antenna of known gain (2.15 dBi) and known input power ( $P_{in}$ ).

ERP can be calculated from EIRP by subtracting the gain of the dipole,  $ERP = EIRP - 2.15dBi$ .

4.Both horizontal and vertical antenna polarities were tested and performed pretest to three orthogonal axis. The worst case emissions were reported.

### 3.2.4. Test Result

Please refer to the Appendix B1.

### 3.3. Peak-to-Average Ratio

#### 3.3.1. Test Setup

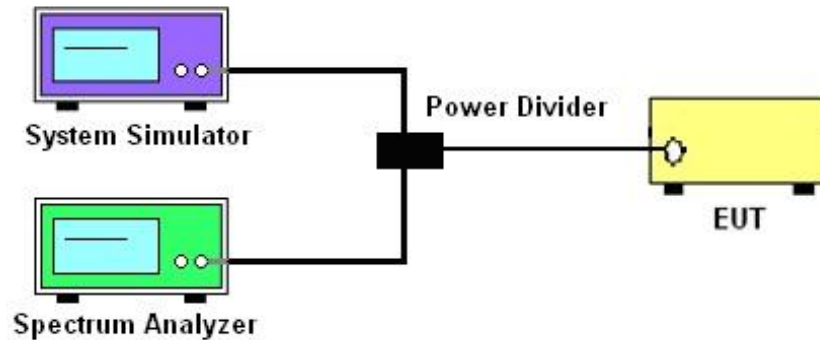

#### 3.3.2. Description of the PAR Measurement

Power Complementary Cumulative Distribution Function (CCDF) curves provide a means for characterizing the power peaks of a digitally modulated signal on a statistical basis. A CCDF curve depicts the probability of the peak signal amplitude exceeding the average power level. Most contemporary measurement instrumentation include the capability to produce CCDF curves for an input signal provided that the instrument's resolution bandwidth can be set wide enough to accommodate the entire input signal bandwidth. In measuring transmissions in this band using an average power technique, the peak-to-average ratio (PAR) of the transmission may not exceed 13 dB.

#### 3.3.3. Test Procedures

1. The testing follows ANSI C63.26 Section 5.2.3.4 (CCDF).
2. The EUT was connected to spectrum and system simulator via a power divider.
3. Set the CCDF (Complementary Cumulative Distribution Function) option in spectrum analyzer.
4. The highest RF powers were measured and recorded the maximum PAPR level associated with a probability of 0.1 %.
5. Record the deviation as Peak to Average Ratio.

#### 3.3.4. Test Result of Peak-to-Average Ratio

Please refer to the AppendixB2.

### 3.4. Occupied Bandwidth

#### 3.4.1. Test Setup

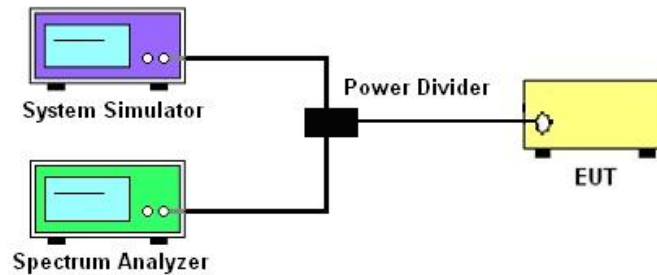

#### 3.4.2. Description of Occupied Bandwidth Measurement

The occupied bandwidth is the width of a frequency band such that, below the lower and above the upper frequency limits, the mean powers emitted are each equal to a specified percentage 0.5% of the total mean transmitted power.

The 26 dB emission bandwidth is defined as the frequency range between two points, one above and one below the carrier frequency, at which the spectral density of the emission is attenuated 26 dB below the maximum in-band spectral density of the modulated signal. Spectral density (power per unit bandwidth) is to be measured with a detector of resolution bandwidth equal to approximately 1.0% of the emission bandwidth.

#### 3.4.3. Test Procedures

1. The testing follows ANSI C63.26 Section 5.4.
2. The EUT was connected to spectrum analyzer and system simulator via a power divider.
3. The spectrum analyzer center frequency is set to the nominal EUT channel center frequency. The span range for the spectrum analyzer shall be between two and five times the anticipated OBW.
4. The nominal resolution bandwidth (RBW) shall be in the range of 1 to 5 % of the anticipated OBW, and the VBW shall be at least 3 times the RBW.
5. Set the detection mode to peak, and the trace mode to max hold.
6. Determine the reference value: Set the EUT to transmit a modulated signal. Allow the trace to stabilize. Set the spectrum analyzer marker to the highest level of the displayed trace.(this is the reference value)
7. Determine the “-26 dB down amplitude” as equal to (Reference Value – X).
8. Place two markers, one at the lowest and the other at the highest frequency of the envelope of the spectral display such that each marker is at or slightly below the “-X dB down amplitude” determined in step 6. If a marker is below this “-X dB down amplitude” value it shall be placed as close as possible to this value. The OBW is the positive frequency difference between the two markers.
9. Use the 99 % power bandwidth function of the spectrum analyzer and report the measured bandwidth.

#### **3.4.4. Test Result of Occupied Bandwidth**

Please refer to the Appendix B3.

### 3.5. Conducted Band Edge

#### 3.5.1. Test Setup

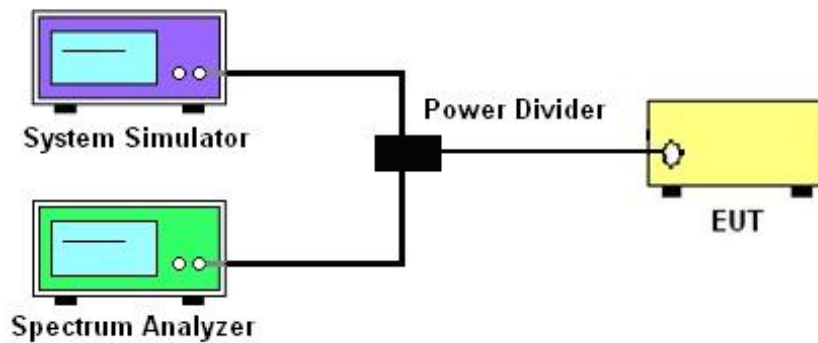

#### 3.5.2. Description of Conducted Band Edge Measurement

##### 22.917(a):

For operations in the 824 – 849 MHz band, the FCC limit is  $43 + 10\log_{10}(P[\text{Watts}])$  dB below the transmitter power  $P(\text{Watts})$  in a 100kHz bandwidth. However, in the 1MHz bands immediately outside and adjacent to the licensee's frequency block, a resolution bandwidth of at least one percent of the emission bandwidth of the fundamental emission of the transmitter may be employed.

##### 24.238 (a):

For operations in the 1850-1910 and 1930-1990 MHz band, the FCC limit is  $43 + 10\log_{10}(P[\text{Watts}])$  dB below the transmitter power  $P(\text{Watts})$  in a 1MHz bandwidth. However, in the 1 MHz bands immediately outside and adjacent to the frequency block a resolution bandwidth of at least one percent of the emission bandwidth of the fundamental emission of the transmitter may be employed.

##### 27.53 (g):

For operations in the 600MHz band and 698 -746 MHz band, the FCC limit is  $43 + 10\log_{10}(P[\text{Watts}])$  dB below the transmitter power  $P(\text{Watts})$  in a 100 kHz bandwidth. However, in the 100 kilohertz bands immediately outside and adjacent to a licensee's frequency block, a resolution bandwidth of at least 30 kHz may be employed.

##### 27.53 (h):

For operations in the 1710 – 1755 MHz and 1710 – 1780 MHz band, the FCC limit is  $43 + 10\log_{10}(P[\text{Watts}])$  dB below the transmitter power  $P(\text{Watts})$  in a 1 MHz bandwidth. However, in the 1MHz bands immediately outside and adjacent to the licensee's frequency block, a resolution bandwidth of at least one percent of the emission bandwidth of the fundamental emission of the transmitter may be employed.

**3.5.3. Test Procedures**

1. The testing follows ANSI C63.26 section 5.7
2. The EUT was connected to spectrum analyzer and system simulator via a power divider.
3. The band edges of low and high channels for the highest RF powers were measured.
4. Set RBW  $\geq$  1% EBW in the 1MHz band immediately outside and adjacent to the band edge.
5. Beyond the 1 MHz band from the band edge, RBW=1MHz was used or a narrower RBW was used and the measured power was integrated over the full required measurement bandwidth of 1 MHz.
6. Set spectrum analyzer with RMS detector.
7. The RF fundamental frequency should be excluded against the limit line in the operating frequency band.
8. Checked that all the results comply with the emission limit line.

Example:

$$\begin{aligned} & \text{The limit line is derived from } 43 + 10\log(P)\text{dB below the transmitter power } P(\text{Watts}) \\ & = P(\text{W}) - [43 + 10\log(P)] \text{ (dB)} \\ & = [30 + 10\log(P)] \text{ (dBm)} - [43 + 10\log(P)] \text{ (dB)} = -13\text{dBm} \end{aligned}$$

9. When using the integration method, the starting frequency of the integration shall be centered at one-half of the RBW away from the band edge.

**3.5.4. Test Result of Conducted Band Edge**

Please refer to the Appendix B4.

### 3.6. Conducted Spurious Emission

#### 3.6.1. Test Setup

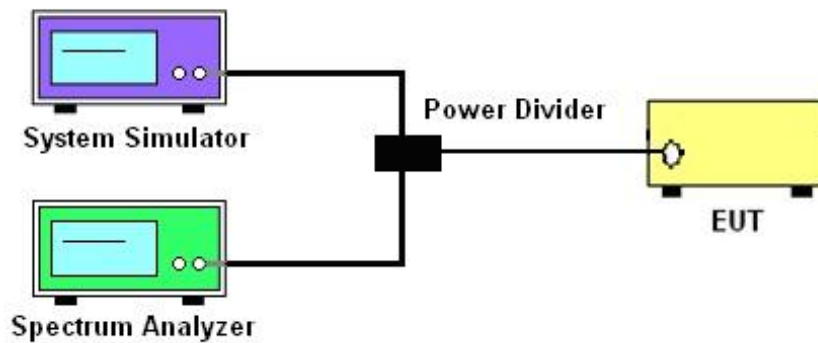

#### 3.6.2. Description of Conducted Spurious Emission Measurement

The power of any emission outside of the authorized operating frequency ranges must be lower than the transmitter power (P) by a factor of at least  $43 + 10 \log (P)$  dB.

It is measured by means of a calibrated spectrum analyzer and scanned from 30 MHz up to a frequency including its 10th harmonic.

#### 3.6.3. Test Procedures

1. The testing follows ANSI C63.26 section 5.7
2. The EUT was connected to spectrum analyzer and system simulator via a power divider.
3. The RF output of EUT was connected to the spectrum analyzer by RF cable and attenuator. The path loss was compensated to the results for each measurement.
4. The middle channel for the highest RF power within the transmitting frequency was measured.
5. The conducted spurious emission for the whole frequency range was taken.
6. Make the measurement with the spectrum analyzer's RBW = 1MHz, VBW = 3MHz.
7. Set spectrum analyzer with RMS detector.
8. Taking the record of maximum spurious emission.
9. The RF fundamental frequency should be excluded against the limit line in the operating frequency band
10. The limit line is derived from  $43 + 10\log(P)$ dB below the transmitter power P(Watts)
 
$$= P(W) - [43 + 10\log(P)] \text{ (dB)} = [30 + 10\log(P)] \text{ (dBm)} - [43 + 10\log(P)] \text{ (dB)} = -13\text{dBm}.$$

#### 3.6.4. Test Result of Conducted Spurious Emission

Please refer to the Appendix B5.

### 3.7. Frequency Stability

#### 3.7.1. Test Setup

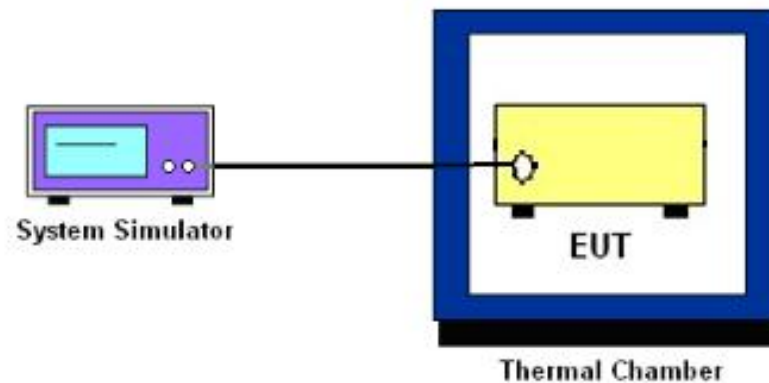

#### 3.7.2. Description of Frequency Stability Measurement

The frequency stability shall be measured by variation of ambient temperature and variation of primary supply voltage to ensure that the fundamental emission stays within the authorized frequency block. The frequency stability of the transmitter shall be maintained within  $\pm 0.00025\%$  ( $\pm 2.5\text{ppm}$ ) of the center frequency.

#### 3.7.3. Test Procedures for Temperature Variation

1. The testing follows ANSI C63.26 section 5.6.4.
2. The EUT was set up in the thermal chamber and connected with the system simulator.
3. With power OFF, the temperature was decreased to  $-30^{\circ}\text{C}$  and the EUT was stabilized before testing. Power was applied and the maximum change in frequency was recorded within one minute.
4. With power OFF, the temperature was raised in  $10^{\circ}\text{C}$  step up to  $50^{\circ}\text{C}$ . The EUT was stabilized at each step for at least half an hour. Power was applied and the maximum frequency change was recorded within one minute.

#### 3.7.4. Test Procedures for Voltage Variation

1. The testing follows ANSI C63.26 section 5.6.5
2. The EUT was placed in a temperature chamber at  $20\pm 5^{\circ}\text{C}$  and connected with the system simulator.
3. The power supply voltage to the EUT was varied from 85% to 115% of the nominal value for other than hand carried battery equipment.
4. For hand carried, battery powered equipment, reduce the primary ac or dc supply voltage to the battery operating end point, which shall be specified by the manufacturer.
5. The variation in frequency was measured for the worst case.

#### 3.7.5. Test Result of Frequency Stability

Please refer to the Appendix B6.

### 3.8. Radiated Spurious Emission

#### 3.8.1. Test Setup

3.8.1.1. For radiated test below 30MHz

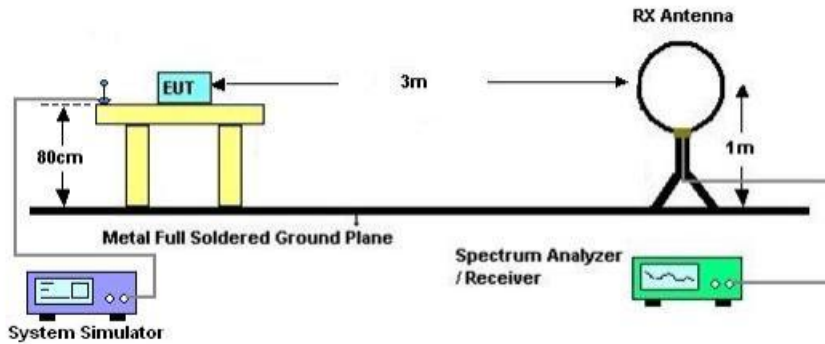

3.8.1.2. For radiated test from 30MHz to 1GHz

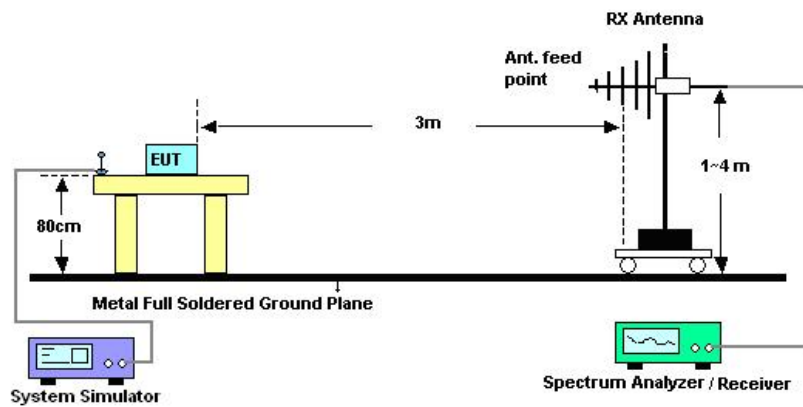

3.8.1.3. For radiated test above 1GHz

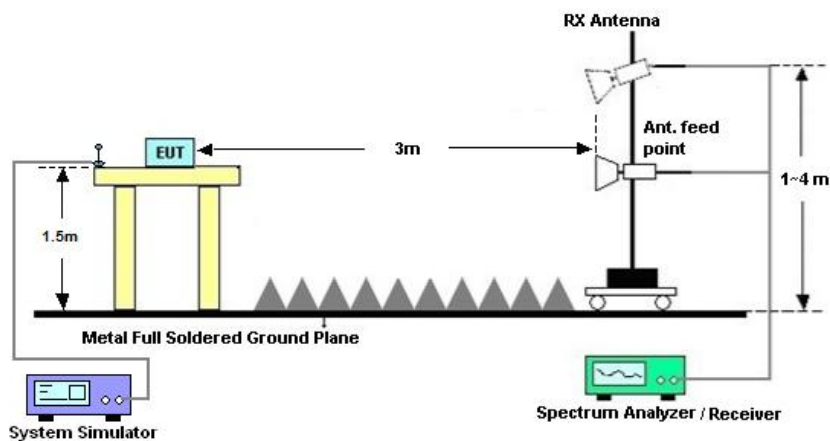

### 3.8.2. Description of Radiated Spurious Emission

The radiated spurious emission was measured by substitution method according to ANSI C63.26.

The power of any emission outside of the authorized operating frequency ranges must be attenuated below the transmitter power (P) by a factor of at least  $43 + 10 \log (P)$  dB.

The spectrum is scanned from 30 MHz up to a frequency including its 10th harmonic.

### 3.8.3. Test Procedures

1. The testing follows ANSI C63.26 Section 5.5
2. The EUT was placed on a turntable with 0.8 meter height for frequency below 1GHz and 1.5 meter height for frequency above 1GHz respectively above ground.
3. The EUT was set 3 meters from the receiving antenna mounted on the antenna tower.
4. The table was rotated 360 degrees to determine the position of the highest spurious emission.
5. The height of the receiving antenna is varied between 1m to 4m to search the maximum spurious emission for both horizontal and vertical polarizations.
6. During the measurement, the system simulator parameters were set to force the EUT transmitting at maximum output power.
7. Make the measurement with the spectrum analyzer's RBW = 1MHz, VBW = 3MHz, taking the record of maximum spurious emission.
8. A horn antenna was substituted in place of the EUT and was driven by a signal generator.
9. Tune the output power of signal generator to the same emission level with EUT maximum spurious emission.
10.  $EIRP \text{ (dBm)} = S.G. \text{ Power} - Tx \text{ Cable Loss} + Tx \text{ Antenna Gain}$
11.  $ERP \text{ (dBm)} = EIRP - 2.15$
12. The RF fundamental frequency should be excluded against the limit line in the operating frequency band.

The limit line is derived from  $43 + 10\log(P)$ dB below the transmitter power P(Watts)  
 $= P(W) - [43 + 10\log(P)] \text{ (dB)}$   
 $= [30 + 10\log(P)] \text{ (dBm)} - [43 + 10\log(P)] \text{ (dB)}$   
 $= -13\text{dBm}.$

### 3.8.4. Test Result of Radiated Spurious Emission

The low frequency, which started from 9 kHz to 30 MHz, was pre-scanned and the result which was 20dB lower than the limit line was not reported.

For frequencies above 30 MHz, the test results are as follows

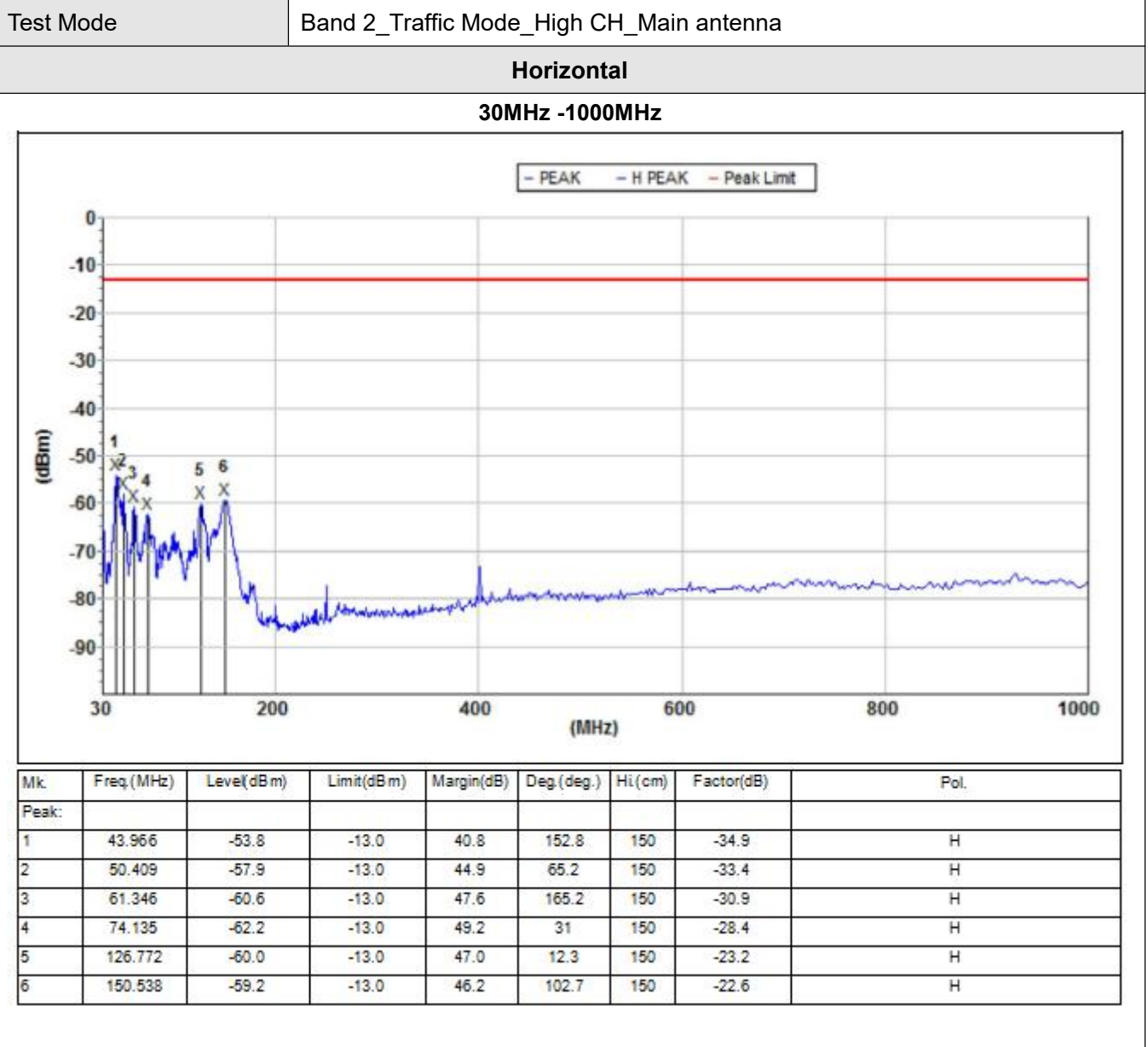
**Test Results**
**Radiated spurious emissions - MS allocated a channel**

Test Mode

Band 2\_Traffic Mode\_High CH\_Main antenna

Vertical

30MHz -1000MHz

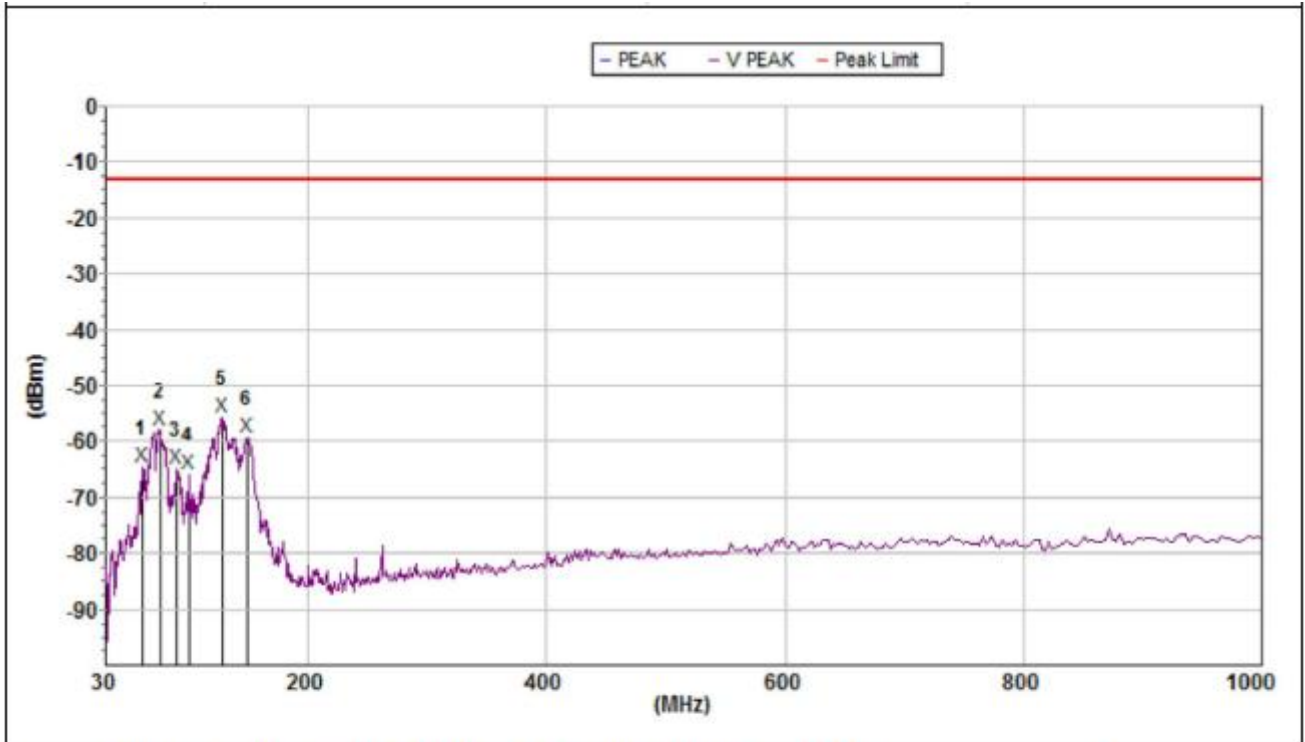

Mk.	Freq.(MHz)	Level(dBm)	Limit(dBm)	Margin(dB)	Deg.(deg.)	Hi.(cm)	Factor(dB)	Pol.
Peak:								
1	61.995	-64.5	-13.0	51.5	278.9	150	-31.9	V
2	75.446	-57.8	-13.0	44.8	1.8	150	-27.9	V
3	89.905	-64.8	-13.0	51.8	6	150	-25.3	V
4	99.528	-65.7	-13.0	52.7	191.7	150	-23.6	V
5	127.665	-55.5	-13.0	42.5	93.5	150	-20.3	V
6	148.962	-59.3	-13.0	46.3	161.7	150	-21.4	V

Test Mode

Band 2\_Traffic Mode\_High CH\_Main antenna

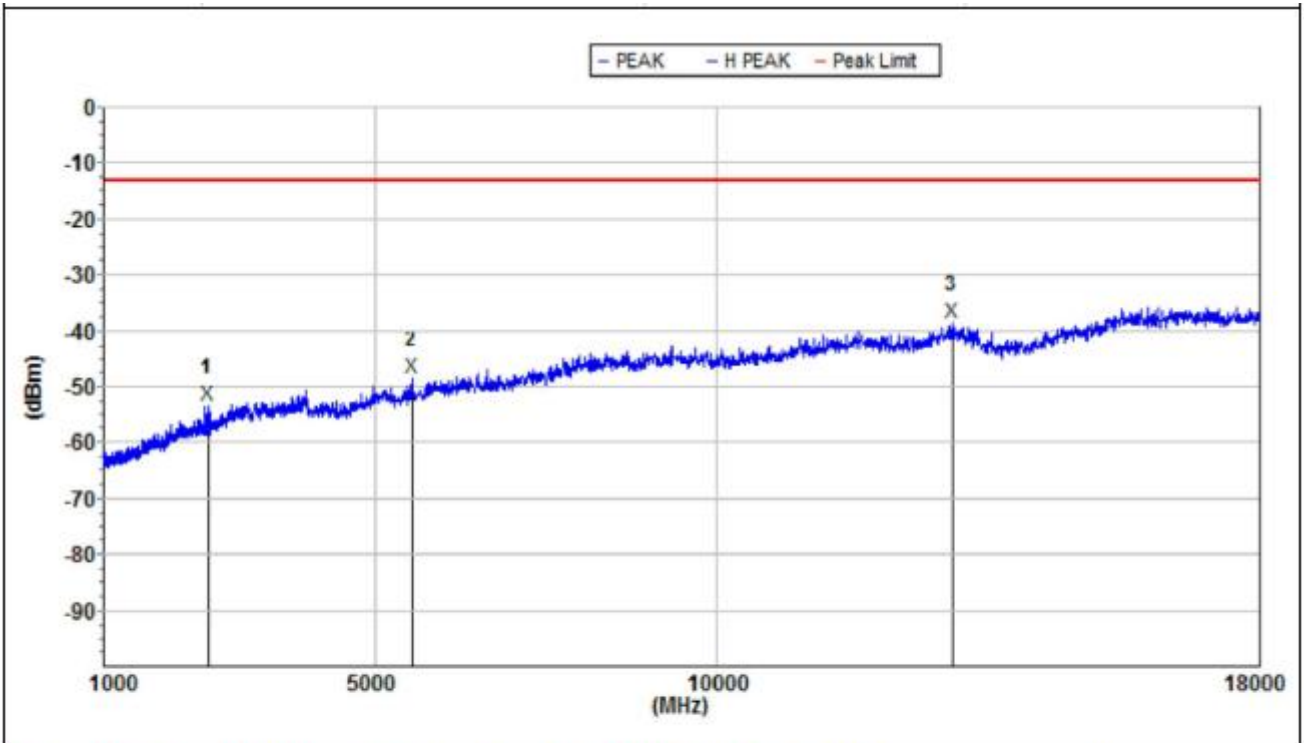
**Horizontal**
**1000MHz -4000MHz**

Mk	Freq (MHz)	Level (dBm)	Limit (dBm)	Margin (dB)	Deg (deg.)	Hi (cm)	Factor (dB)	Pol.
Peak:								
1	2551.000	-53.3	-13.0	40.3	0	150	-11.4	H
2	5533.000	-48.5	-13.0	35.5	359.9	150	-1.7	H
3	13471.000	-38.5	-13.0	25.5	359.9	150	9.8	H

Test Mode

Band 2\_Traffic Mode\_High CH\_Main antenna

Vertical

1000MHz -4000MHz

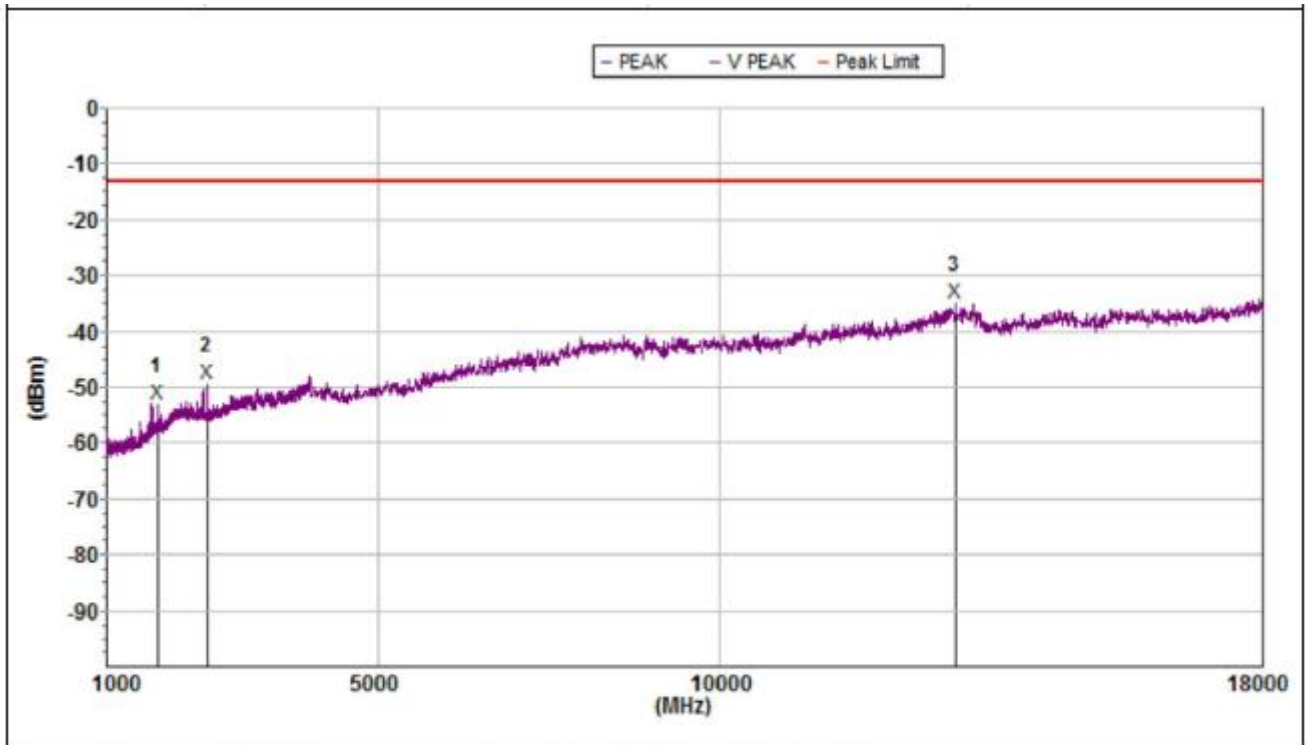

Mk.	Freq.(MHz)	Level(dBm)	Limit(dBm)	Margin(dB)	Deg.(deg.)	Hi.(cm)	Factor(dB)	Pol.
Peak:								
1	1750.000	-53.0	-13.0	40.0	153	150	-10.7	V
2	2500.000	-49.2	-13.0	36.2	153	150	-9.1	V
3	13478.000	-35.0	-13.0	22.0	0	150	13.4	V

Test Mode

Band 2\_Traffic Mode\_Mid CH\_Main antenna

**Horizontal**

30MHz -1000MHz

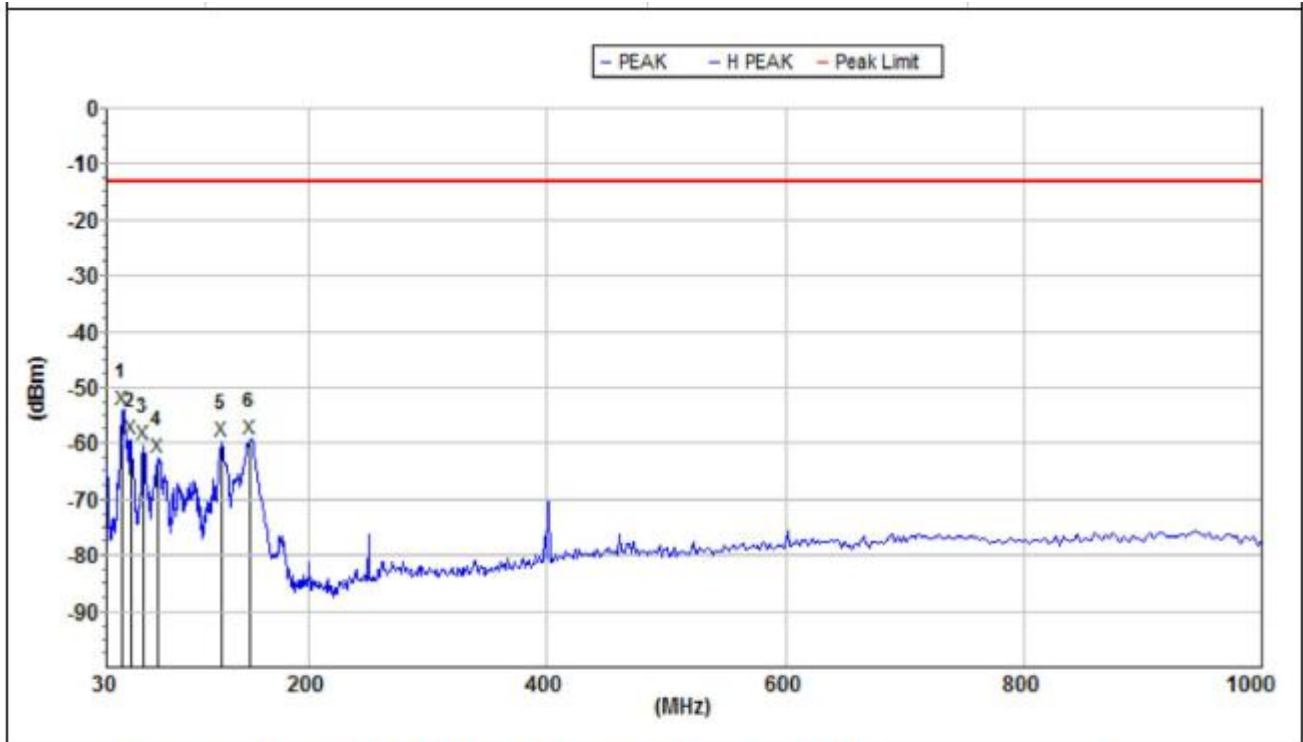

Mk.	Freq.(MHz)	Level(dBm)	Limit(dBm)	Margin(dB)	Deg.(deg.)	Hi.(cm)	Factor(dB)	Pol.
Peak:								
1	44.120	-53.8	-13.0	40.8	338.9	150	-34.9	H
2	50.232	-59.3	-13.0	46.3	175.6	150	-33.5	H
3	61.132	-60.2	-13.0	47.2	163	150	-31.0	H
4	73.876	-62.6	-13.0	49.6	100.3	150	-28.5	H
5	126.772	-59.6	-13.0	46.6	0.2	150	-23.2	H
6	151.067	-59.3	-13.0	46.3	0.2	150	-22.6	H

Test Mode

Band 2\_Traffic Mode\_Mid CH\_Main antenna

Vertical

30MHz -1000MHz

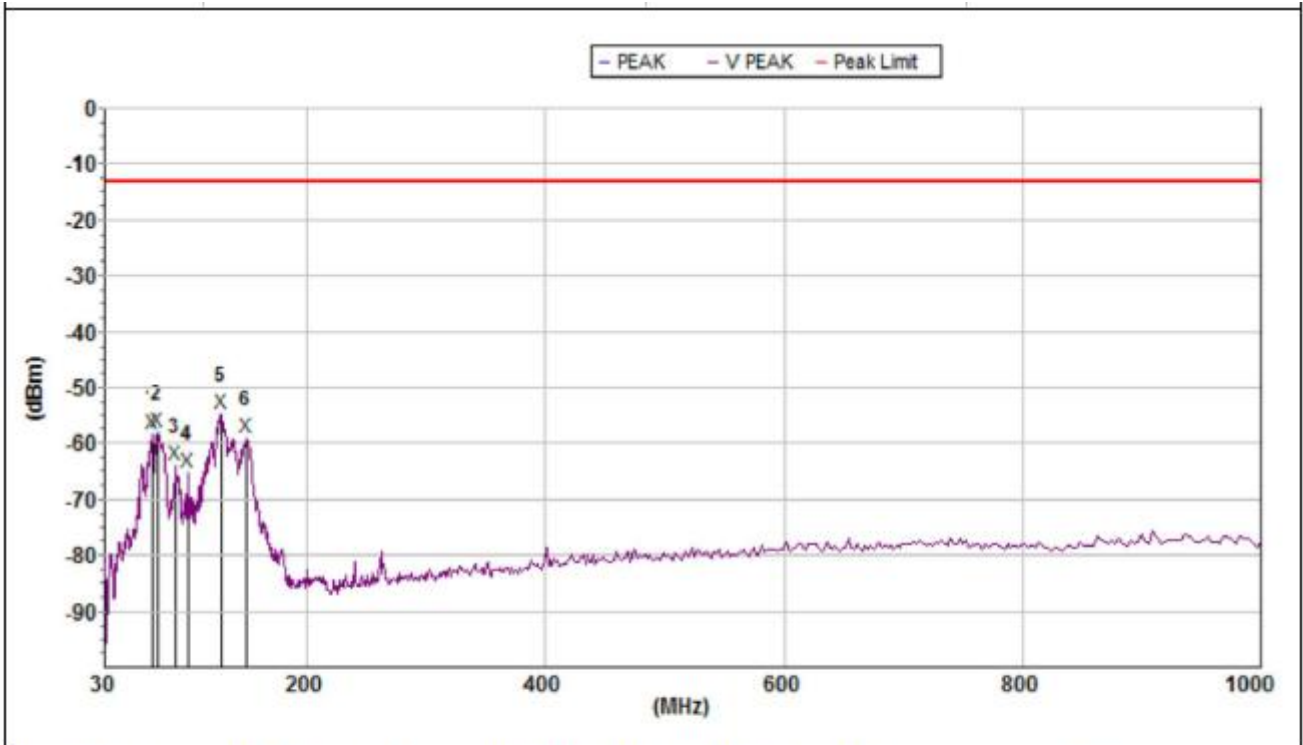

Mk	Freq (MHz)	Level (dBm)	Limit (dBm)	Margin (dB)	Deg (deg.)	Hi (cm)	Factor (dB)	Pol.
Peak:								
1	70.584	-58.3	-13.0	45.3	240.6	150	-28.8	V
2	74.919	-57.9	-13.0	44.9	328.8	150	-28.0	V
3	89.905	-63.8	-13.0	50.8	140.1	150	-25.3	V
4	99.528	-65.0	-13.0	52.0	353.8	150	-23.6	V
5	127.665	-54.7	-13.0	41.7	152.7	150	-20.3	V
6	149.486	-59.0	-13.0	46.0	358.1	150	-21.4	V

Test Mode

Band 2\_Traffic Mode\_Mid CH\_Main antenna

## Horizontal

1000MHz -4000MHz

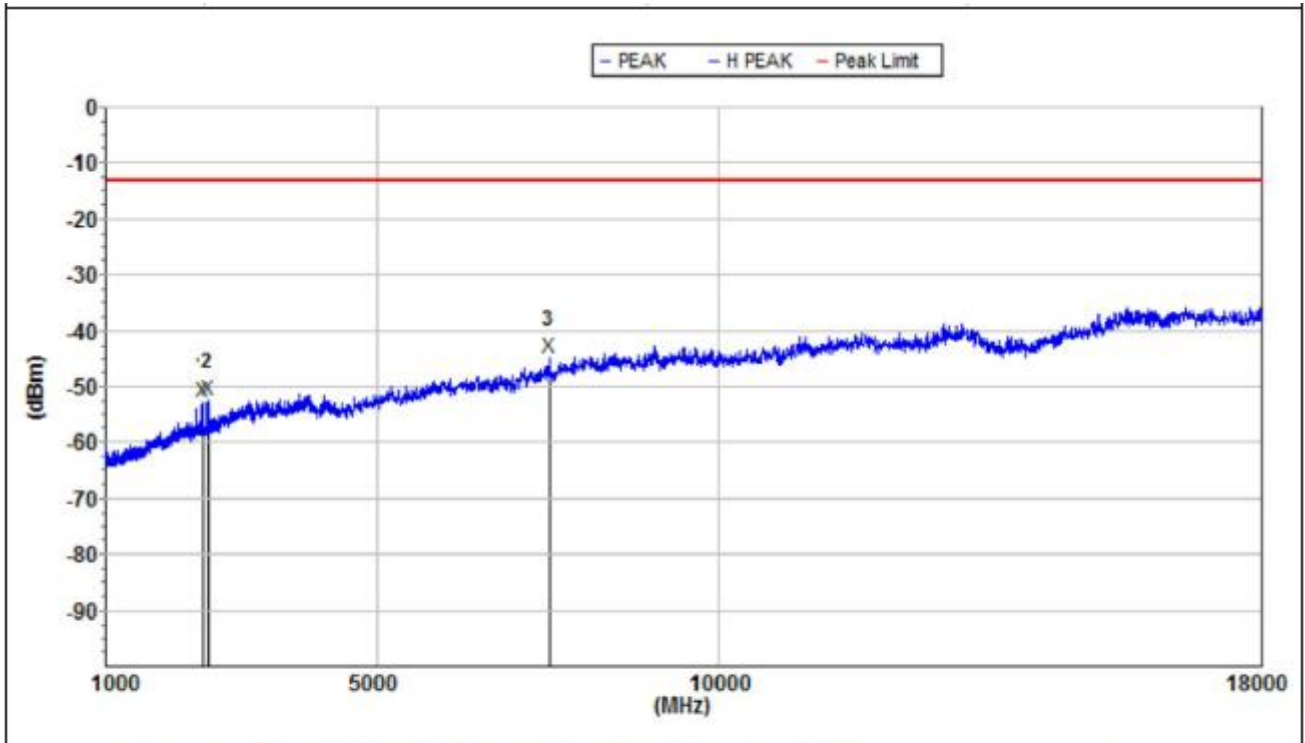

Mk.	Freq (MHz)	Level(dBm)	Limit(dBm)	Margin(dB)	Deg (deg.)	Ht (cm)	Factor(dB)	Pol.
Peak:								
1	2423.500	-52.5	-13.0	39.5	134.2	150	-11.7	H
2	2521.000	-52.2	-13.0	39.2	32	150	-11.6	H
3	7521.000	-44.6	-13.0	31.6	359.7	150	2.5	H

Test Mode

Band 2\_Traffic Mode\_Mid CH\_Main antenna

Vertical

1000MHz -4000MHz

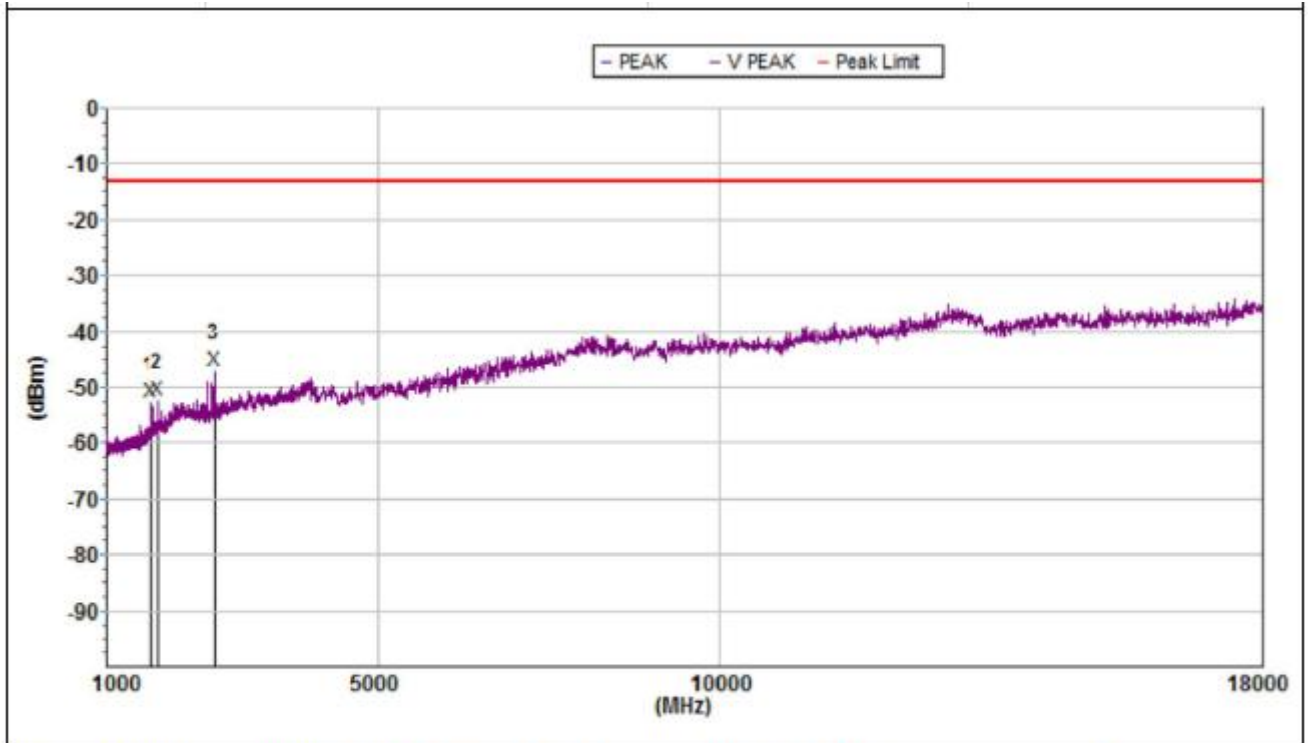

Mk	Freq (MHz)	Level (dBm)	Limit (dBm)	Margin (dB)	De	Hi (cm)	Factor (dB)	Pol.
Peak:								
1	1664.500	-52.7	-13.0	39.7	188.6	150	-11.8	V
2	1750.000	-52.3	-13.0	39.3	170.1	150	-10.7	V
3	2581.000	-47.2	-13.0	34.2	151.6	150	-8.7	V

Test Mode

Band 2\_Traffic Mode\_Low CH\_Main antenna

**Horizontal**

30MHz -1000MHz

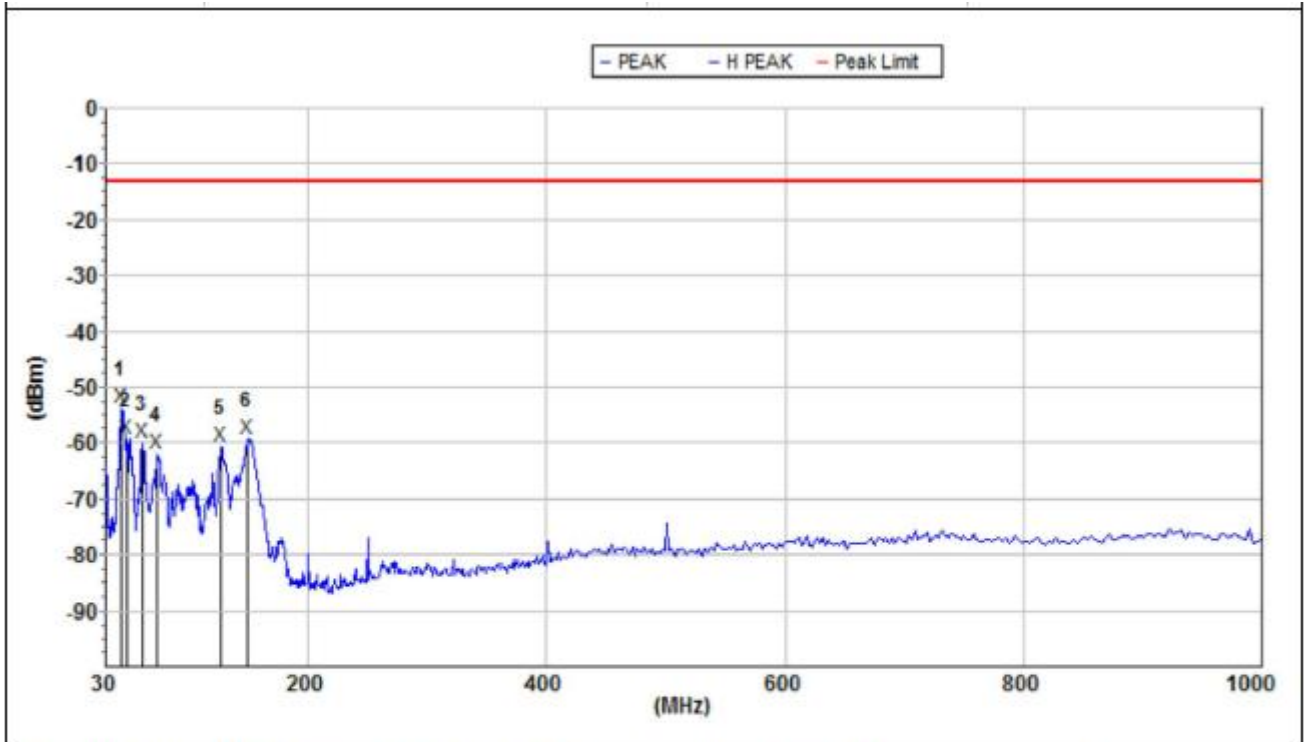

Mk.	Freq.(MHz)	Level(dBm)	Limit(dBm)	Margin(dB)	De (+)	Ht.(cm)	Factor(dB)	Pol.
Peak:								
1	44.120	-53.5	-13.0	40.5	137.3	150	-34.9	H
2	47.826	-59.3	-13.0	46.3	30.9	150	-34.0	H
3	61.346	-59.9	-13.0	46.9	0	150	-30.9	H
4	73.876	-62.0	-13.0	49.0	43.4	150	-28.5	H
5	127.218	-60.4	-13.0	47.4	93.4	150	-23.1	H
6	149.486	-59.2	-13.0	46.2	56	150	-22.7	H

Test Mode

Band 2\_Traffic Mode\_Low CH\_Main antenna

Vertical

30MHz -1000MHz

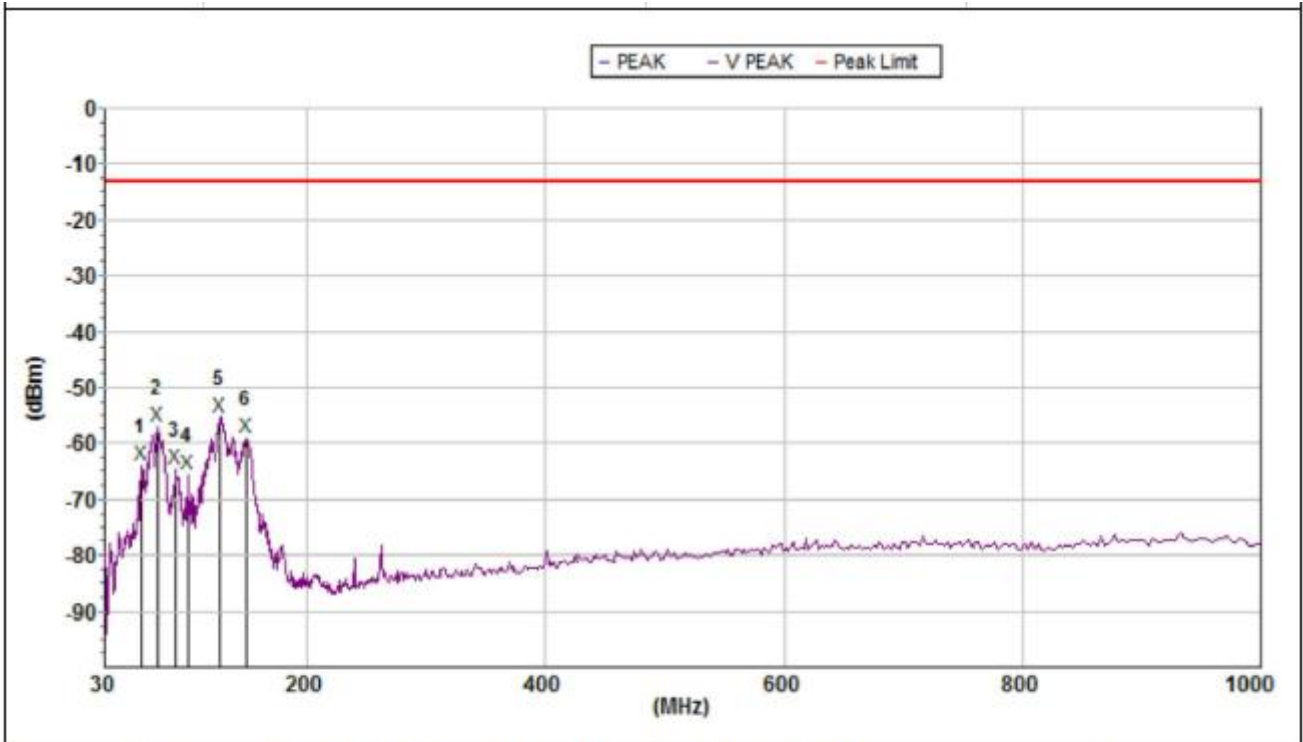

Mk	Freq (MHz)	Level (dBm)	Limit (dBm)	Margin (dB)	De (+)	Hi (cm)	Factor (dB)	Pol.
Peak:								
1	61.995	-63.9	-13.0	50.9	265.7	150	-31.9	V
2	74.919	-57.0	-13.0	44.0	71.2	150	-28.0	V
3	89.905	-64.5	-13.0	51.5	360	150	-25.3	V
4	99.528	-65.6	-13.0	52.6	357.9	150	-23.6	V
5	127.218	-55.3	-13.0	42.3	203.1	150	-20.3	V
6	149.486	-59.0	-13.0	46.0	222	150	-21.4	V

Test Mode

Band 2\_Traffic Mode\_Low CH\_Main antenna

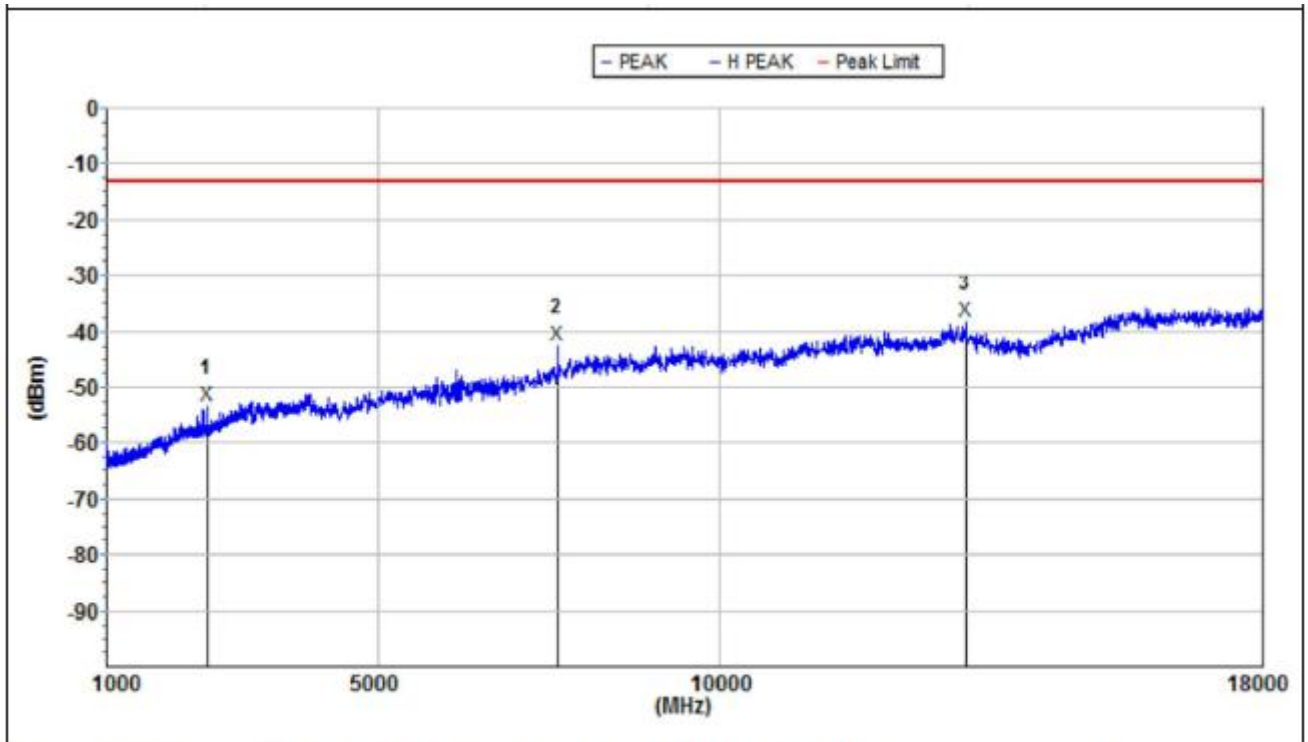
**Horizontal**
**1000MHz -4000MHz**

Mk.	Freq.(MHz)	Level(dBm)	Limit(dBm)	Margin(dB)	Deg.(deg.)	Hi.(cm)	Factor(dB)	Pol.
Peak:								
1	2500.000	-53.4	-13.0	40.4	219.8	150	-11.7	H
2	7633.000	-42.3	-13.0	29.3	359.9	150	3.0	H
3	13639.000	-38.3	-13.0	25.3	359.9	150	9.4	H

Test Mode

Band 2\_Traffic Mode\_Low CH\_Main antenna

Vertical

1000MHz -4000MHz

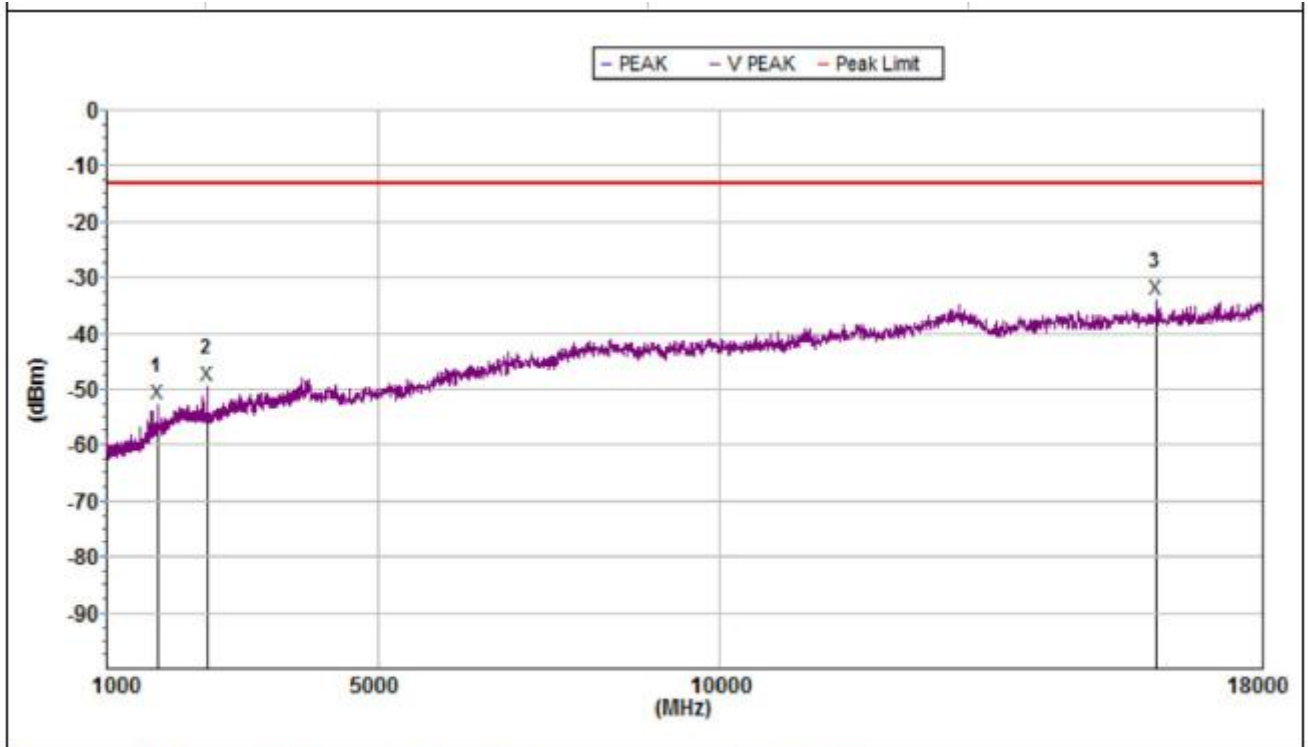

Mk.	Freq.(MHz)	Level(dBm)	Limit(dBm)	Margin(dB)	De (+)	Hi (cm)	Factor(dB)	Pol.
Peak:								
1	1750.000	-52.5	-13.0	39.5	189.5	150	-10.7	V
2	2500.000	-49.5	-13.0	36.5	217.1	150	-9.1	V
3	16446.000	-33.9	-13.0	20.9	0	150	14.0	V

Test Mode

Band 4\_Traffic Mode\_High CH\_Main antenna

**Horizontal**

30MHz -1000MHz

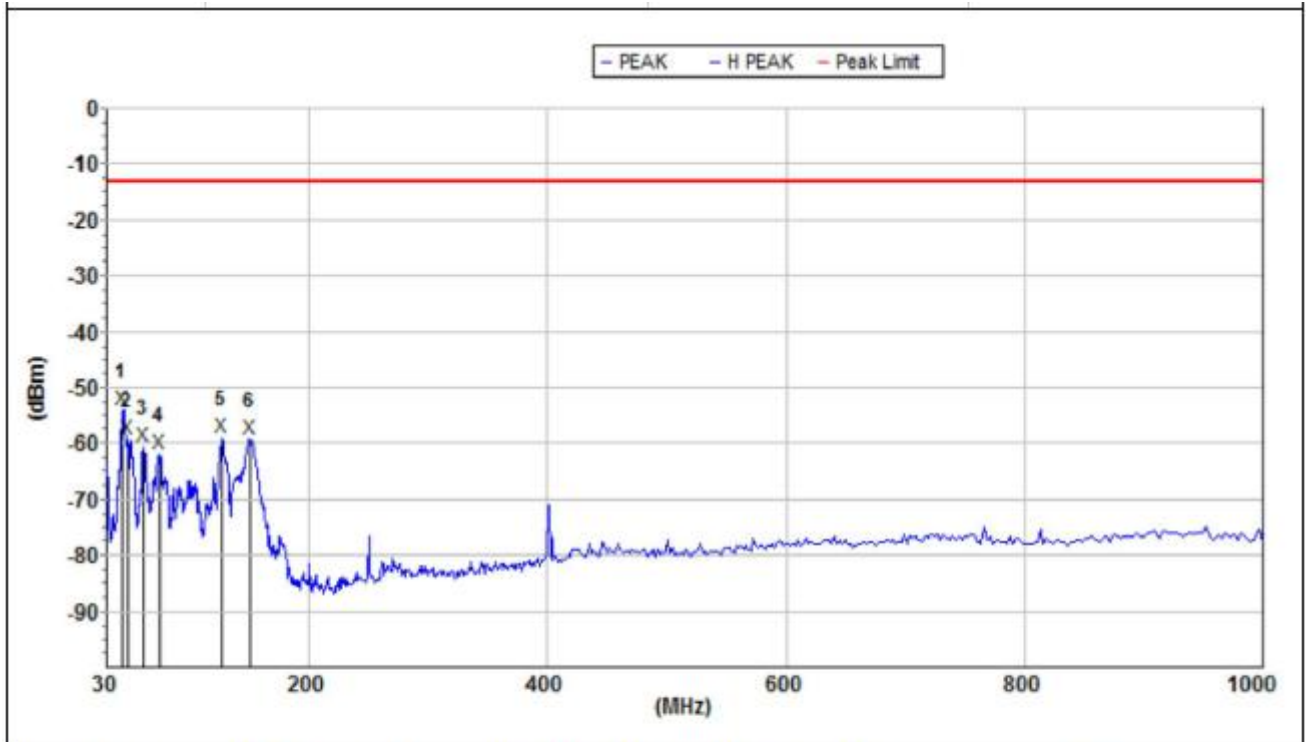

Mk.	Freq.(MHz)	Level(dBm)	Limit(dBm)	Margin(dB)	Deg.(deg.)	Hi.(cm)	Factor(dB)	Pol.
Peak:								
1	43.966	-54.0	-13.0	41.0	0	150	-34.9	H
2	47.659	-59.1	-13.0	46.1	12.6	150	-34.1	H
3	61.132	-60.4	-13.0	47.4	176.2	150	-31.0	H
4	74.657	-62.0	-13.0	49.0	295.7	150	-28.4	H
5	127.218	-58.8	-13.0	45.8	357.1	150	-23.1	H
6	150.538	-59.1	-13.0	46.1	251.7	150	-22.6	H

Test Mode

Band 4\_Traffic Mode\_High CH\_Main antenna

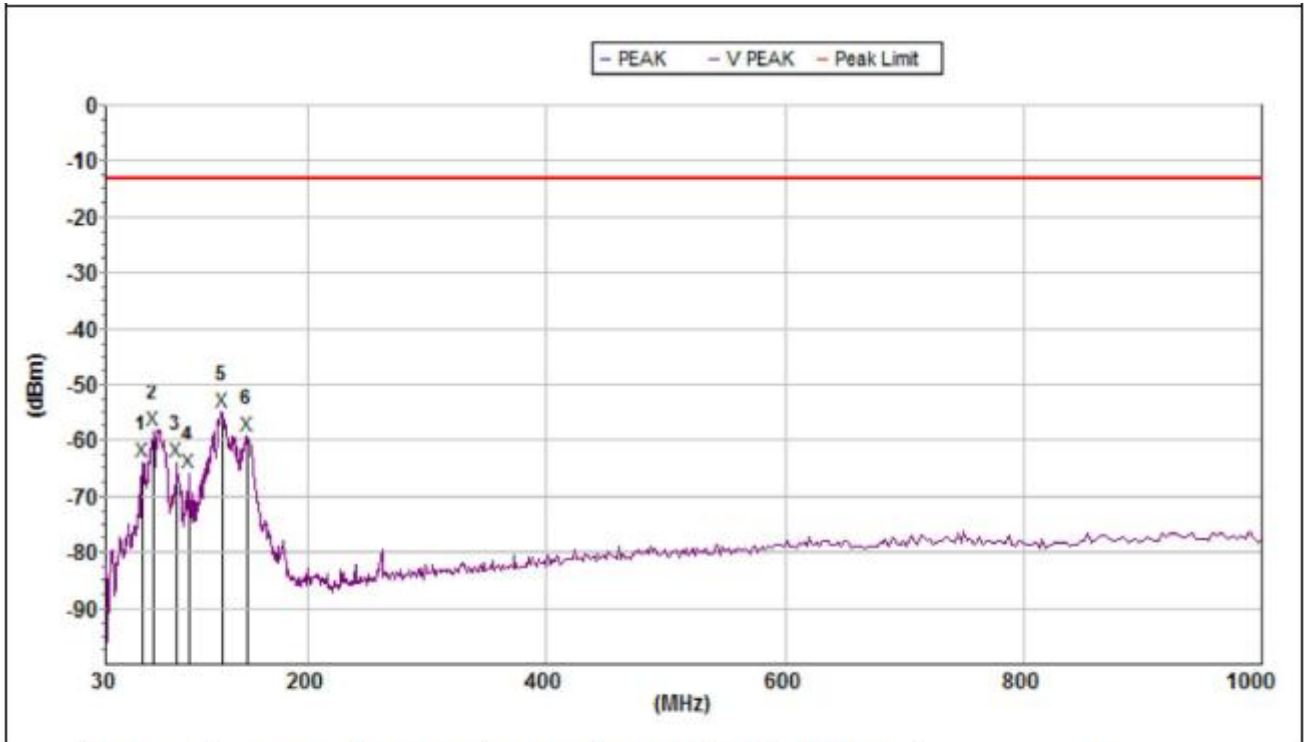
**Vertical**
**30MHz -1000MHz**

Mk.	Freq.(MHz)	Level(dBm)	Limit(dBm)	Margin(dB)	Deg.(deg.)	Ht.(cm)	Factor(dB)	Pol.
Peak:								
1	61.346	-63.7	-13.0	50.7	303.8	150	-32.1	V
2	70.584	-58.1	-13.0	45.1	15.3	150	-28.8	V
3	89.905	-63.9	-13.0	50.9	103	150	-25.3	V
4	99.528	-65.8	-13.0	52.8	197.1	150	-23.6	V
5	127.665	-54.8	-13.0	41.8	291.2	150	-20.3	V
6	149.486	-59.1	-13.0	46.1	360	150	-21.4	V

Test Mode

Band 4\_Traffic Mode\_High CH\_Main antenna

## Horizontal

1000MHz -4000MHz

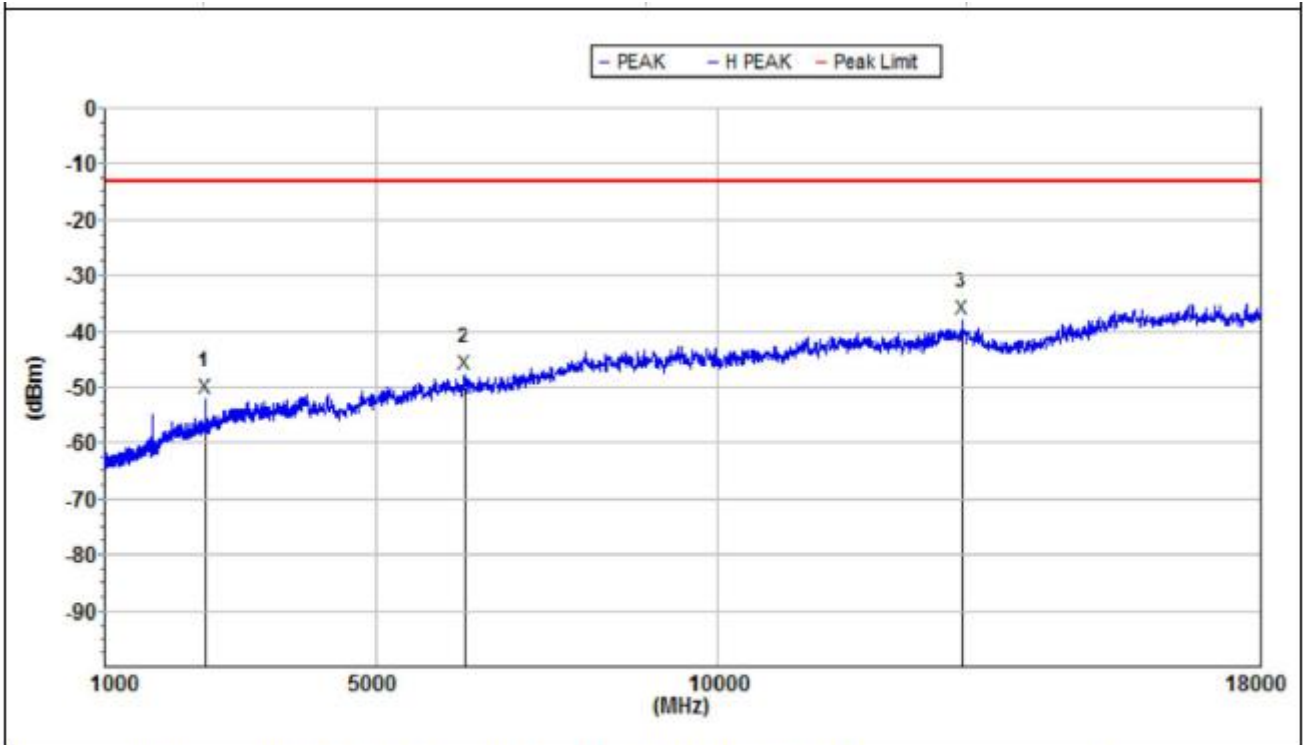

Mk.	Freq.(MHz)	Level(dBm)	Limit(dBm)	Margin(dB)	Deg.(deg.)	Hi(cm)	Factor(dB)	Pol.
Peak:								
1	2500.000	-51.9	-13.0	38.9	220.5	150	-11.6	H
2	6310.000	-47.7	-13.0	34.7	0.9	150	0.6	H
3	13618.000	-37.9	-13.0	24.9	0.9	150	9.5	H

Test Mode

Band 4\_Traffic Mode\_High CH\_Main antenna

Vertical

1000MHz -4000MHz

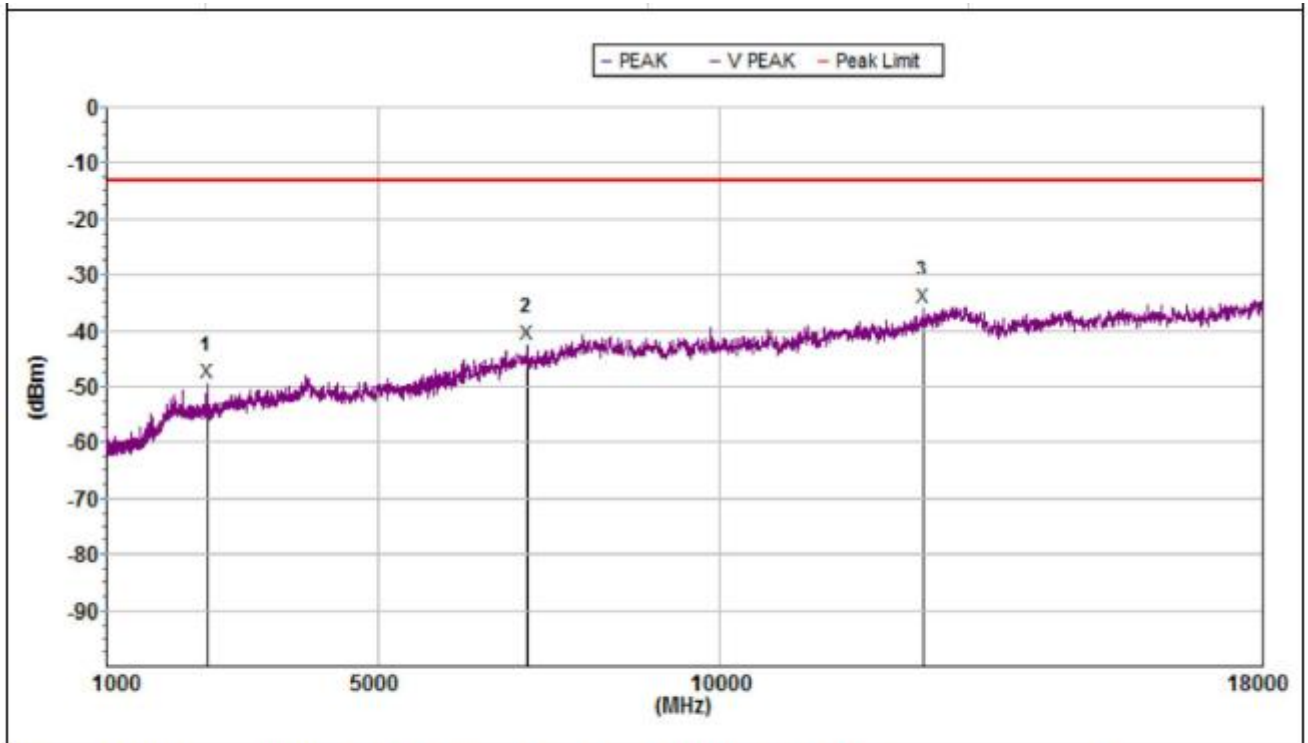

Mk.	Freq.(MHz)	Level(dBm)	Limit(dBm)	Margin(dB)	Deg.(deg.)	HI(cm)	Factor(dB)	Pol.
Peak:								
1	2500.000	-49.2	-13.0	36.2	189.8	150	-9.0	V
2	7185.000	-42.3	-13.0	29.3	359.6	150	4.7	V
3	13002.000	-35.8	-13.0	22.8	359.6	150	11.3	V

Test Mode

Band 4\_Traffic Mode\_Mid CH\_Main antenna

**Horizontal**

30MHz -1000MHz

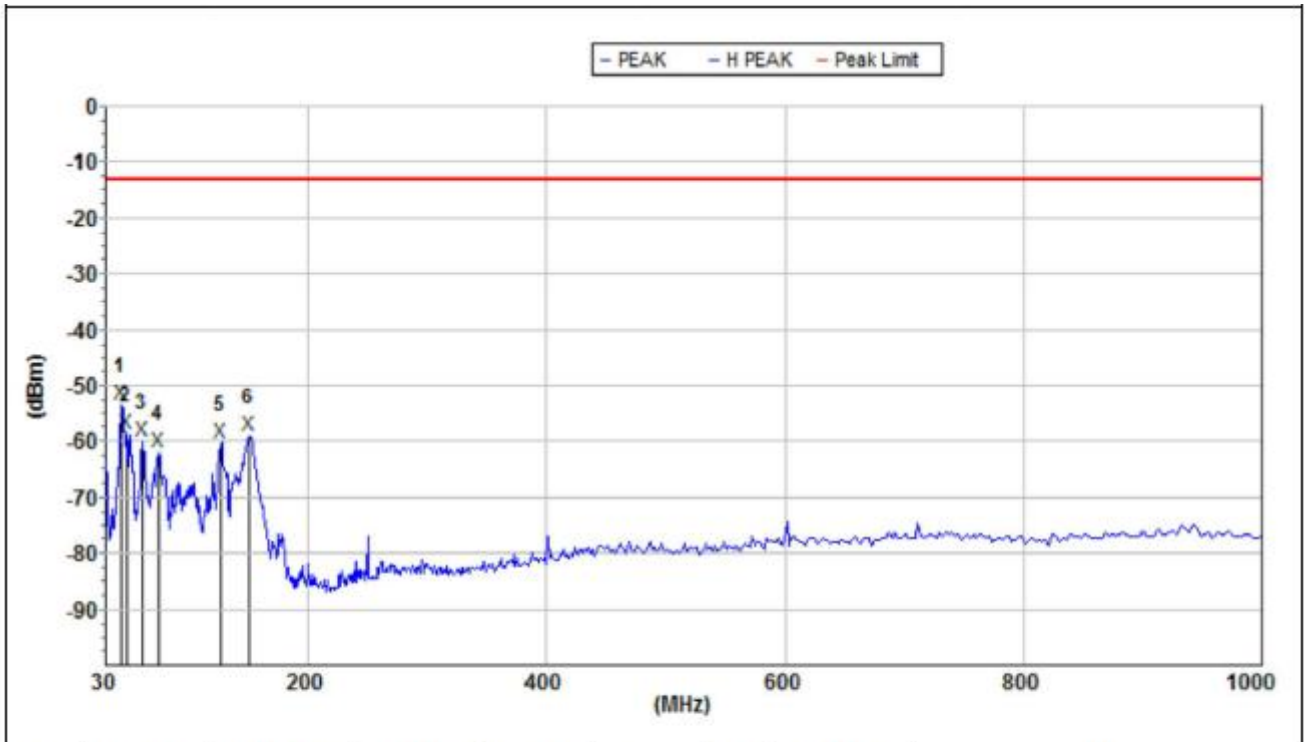

Mk	Freq.(MHz)	Level(dBm)	Limit(dBm)	Margin(dB)	De + )	Hi (cm)	Factor(dB)	Pol.
Peak:								
1	44.120	-53.3	-13.0	40.3	338.3	150	-34.9	H
2	47.826	-58.4	-13.0	45.4	250.4	150	-34.0	H
3	61.132	-60.0	-13.0	47.0	12.4	150	-31.0	H
4	74.919	-61.8	-13.0	48.8	219	150	-28.3	H
5	126.772	-60.1	-13.0	47.1	24.7	150	-23.2	H
6	150.538	-58.8	-13.0	45.8	80.9	150	-22.6	H

Test Mode

Band 4\_Traffic Mode\_Mid CH\_Main antenna

**Vertical**

30MHz -1000MHz

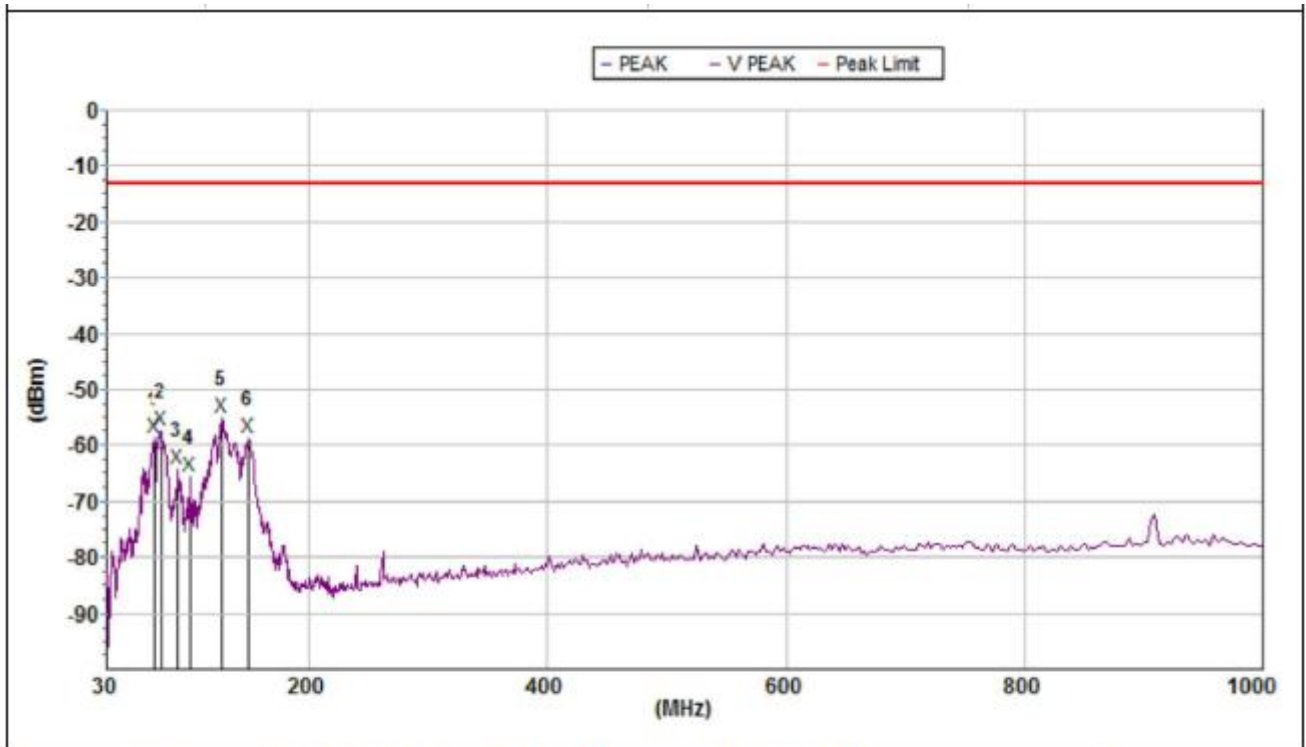

Mk.	Freq.(MHz)	Level(dBm)	Limit(dBm)	Margin(dB)	Da	Hi.(cm)	Factor(dB)	Pol.
Peak:					+			
1	70.090	-58.5	-13.0	45.5	190.4	150	-28.9	V
2	75.977	-57.1	-13.0	44.1	347.5	150	-27.8	V
3	89.905	-64.3	-13.0	51.3	89.9	150	-25.3	V
4	99.528	-65.3	-13.0	52.3	3.2	150	-23.6	V
5	127.218	-55.0	-13.0	42.0	39.6	150	-20.3	V
6	149.486	-58.6	-13.0	45.6	247	150	-21.4	V

Test Mode

Band 4\_Traffic Mode\_Mid CH\_Main antenna

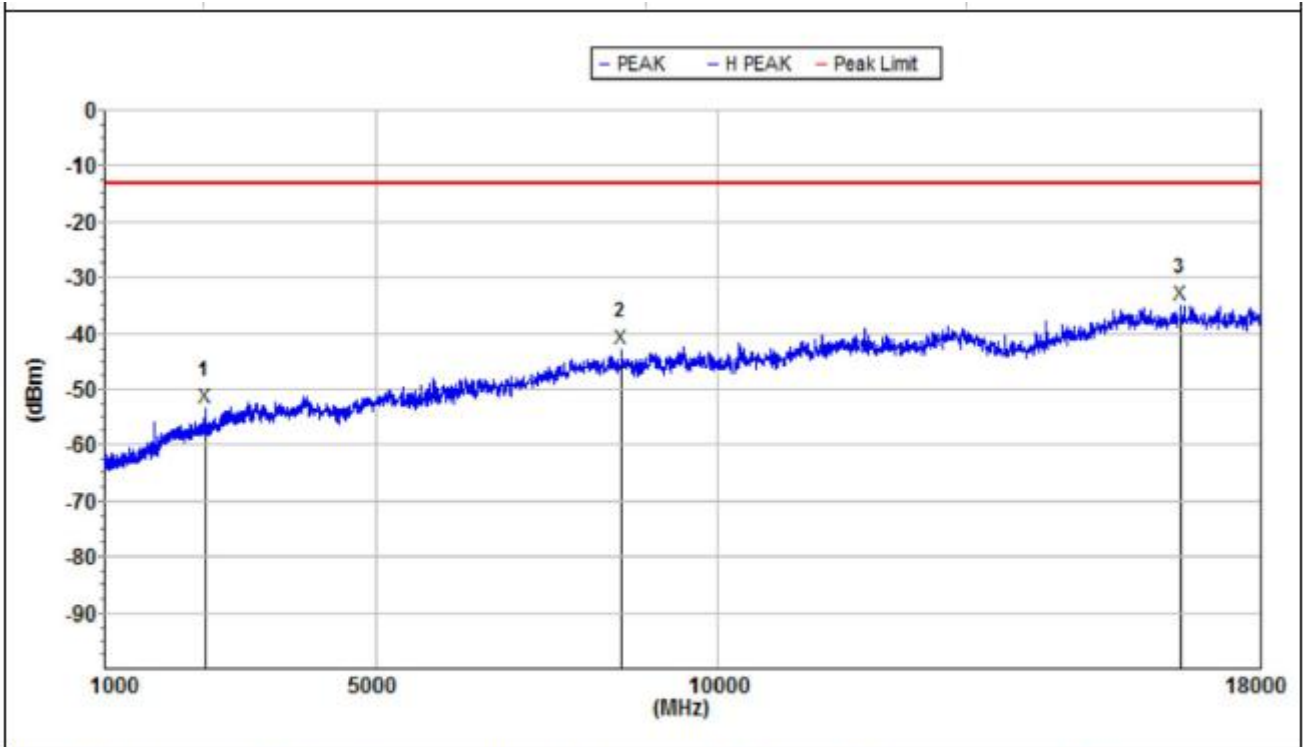
**Horizontal**
**1000MHz -4000MHz**

Mk.	Freq (MHz)	Level(dBm)	Limit(dBm)	Margin(dB)	Deg.(deg.)	Hi(cm)	Factor(dB)	Pol.
Peak:								
1	2500.000	-53.2	-13.0	40.2	72.8	150	-11.6	H
2	8599.000	-42.9	-13.0	29.9	360	150	4.2	H
3	16824.000	-34.8	-13.0	21.8	360	150	14.1	H

Test Mode

Band 4\_Traffic Mode\_Mid CH\_Main antenna

Vertical

1000MHz -4000MHz

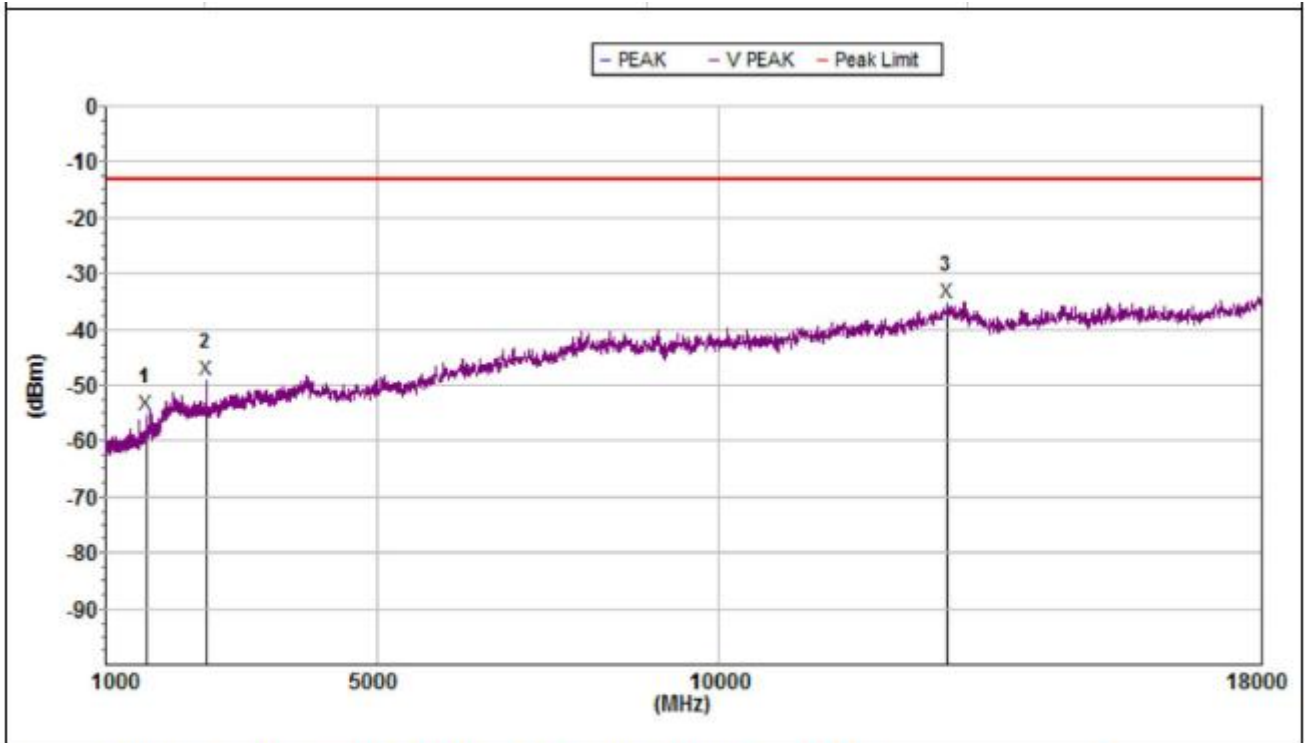

Mk	Freq (MHz)	Level (dBm)	Limit (dBm)	Margin (dB)	Deg (deg.)	Ht (cm)	Factor (dB)	Pol.
Peak:								
1	1600.000	-55.3	-13.0	42.3	161.7	150	-12.8	V
2	2500.000	-48.9	-13.0	35.9	181.3	150	-9.0	V
3	13373.000	-35.1	-13.0	22.1	0	150	13.0	V

Test Mode

Band 4\_Traffic Mode\_Low CH\_Main antenna

Horizontal

30MHz -1000MHz

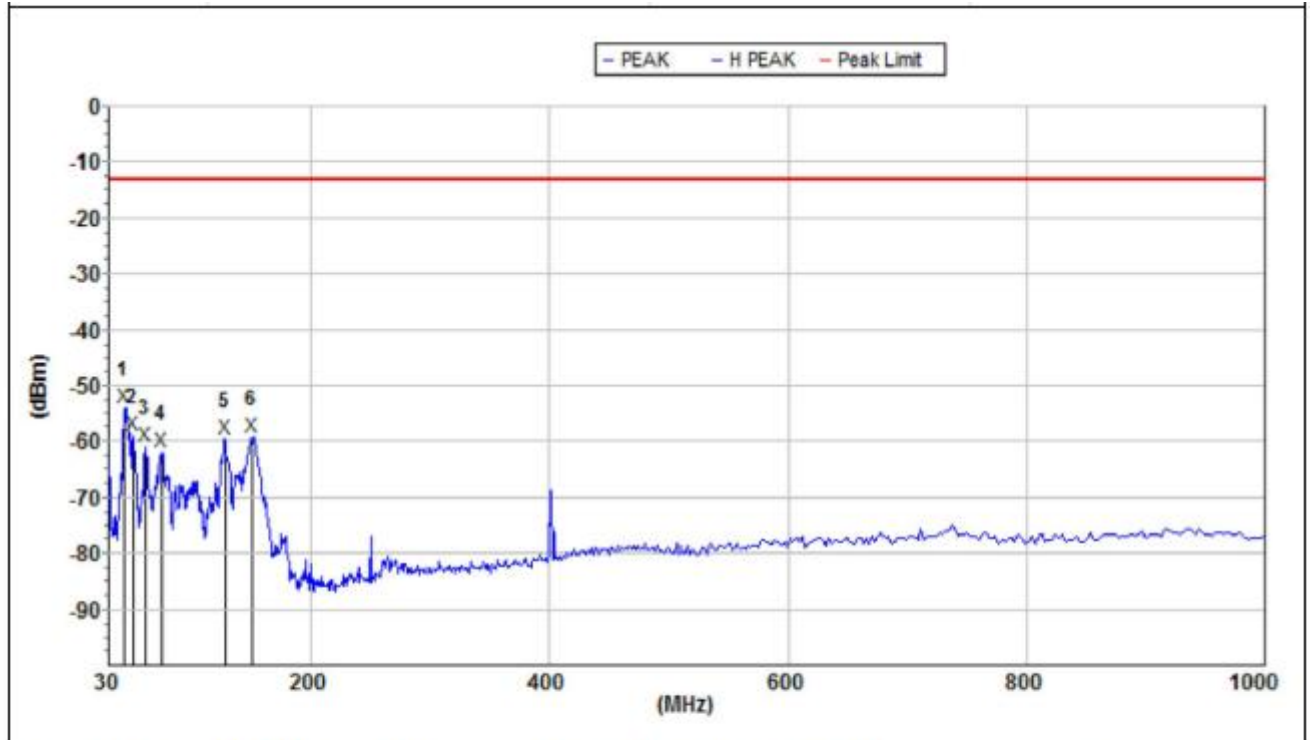

Mk.	Freq.(MHz)	Level(dBm)	Limit(dBm)	Margin(dB)	Deg.(deg.)	Hi(cm)	Factor(dB)	Pol.
Peak:								
1	44.120	-53.8	-13.0	40.8	3.89	150	-34.9	H
2	50.409	-58.9	-13.0	45.9	360	150	-33.4	H
3	61.346	-60.9	-13.0	47.9	272.52	150	-30.9	H
4	74.657	-61.9	-13.0	48.9	15.52	150	-28.3	H
5	127.665	-59.4	-13.0	46.4	341.47	150	-23.1	H
6	150.538	-59.3	-13.0	46.3	115.97	150	-22.6	H

Test Mode

Band 4\_Traffic Mode\_Low CH\_Main antenna

Vertical

30MHz -1000MHz

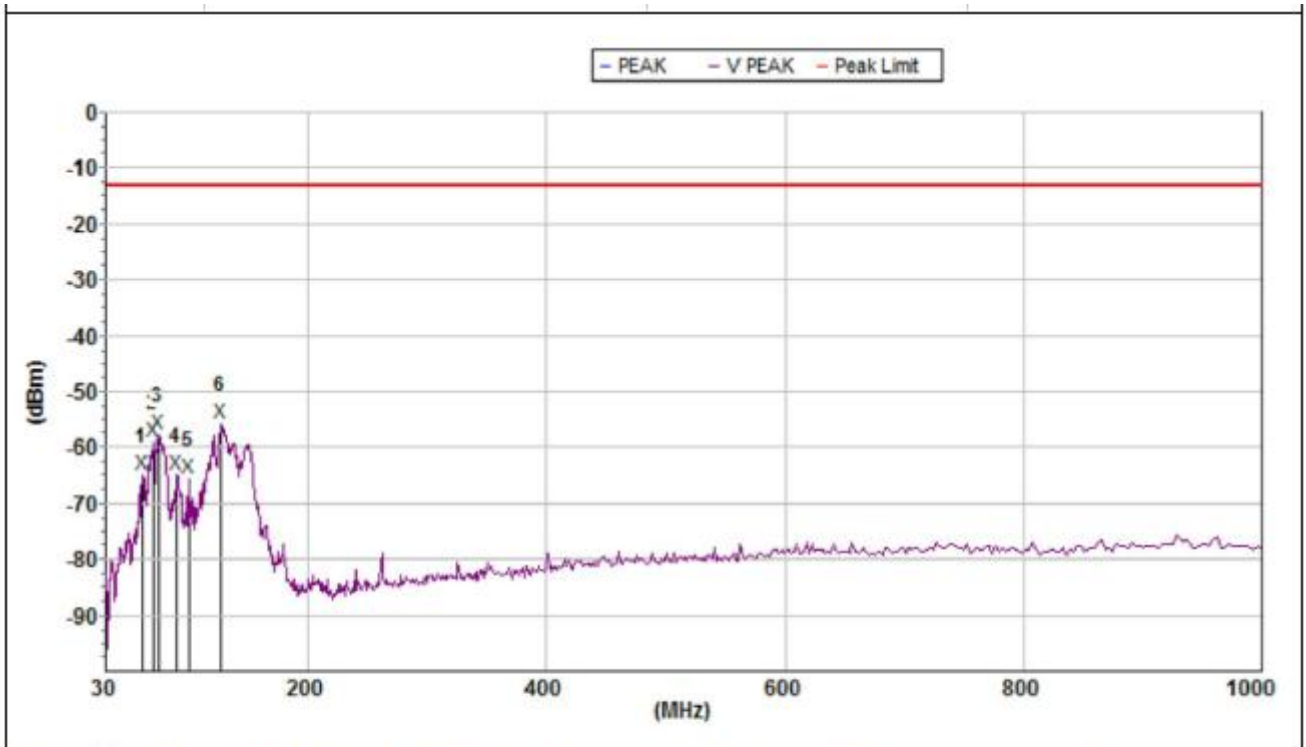

Mk.	Freq.(MHz)	Level(dBm)	Limit(dBm)	Margin(dB)	De	Hi(cm)	Factor(dB)	Pol.
Peak:					+			
1	61.132	-64.8	-13.0	51.8	18.37	150	-32.2	V
2	70.584	-59.0	-13.0	46.0	119.02	150	-28.8	V
3	74.396	-57.6	-13.0	44.6	0	150	-28.1	V
4	89.905	-64.7	-13.0	51.7	200.27	150	-25.3	V
5	99.528	-65.4	-13.0	52.4	225.32	150	-23.6	V
6	126.772	-55.5	-13.0	42.5	74.92	150	-20.2	V

Test Mode

Band 4\_Traffic Mode\_Low CH\_Main antenna

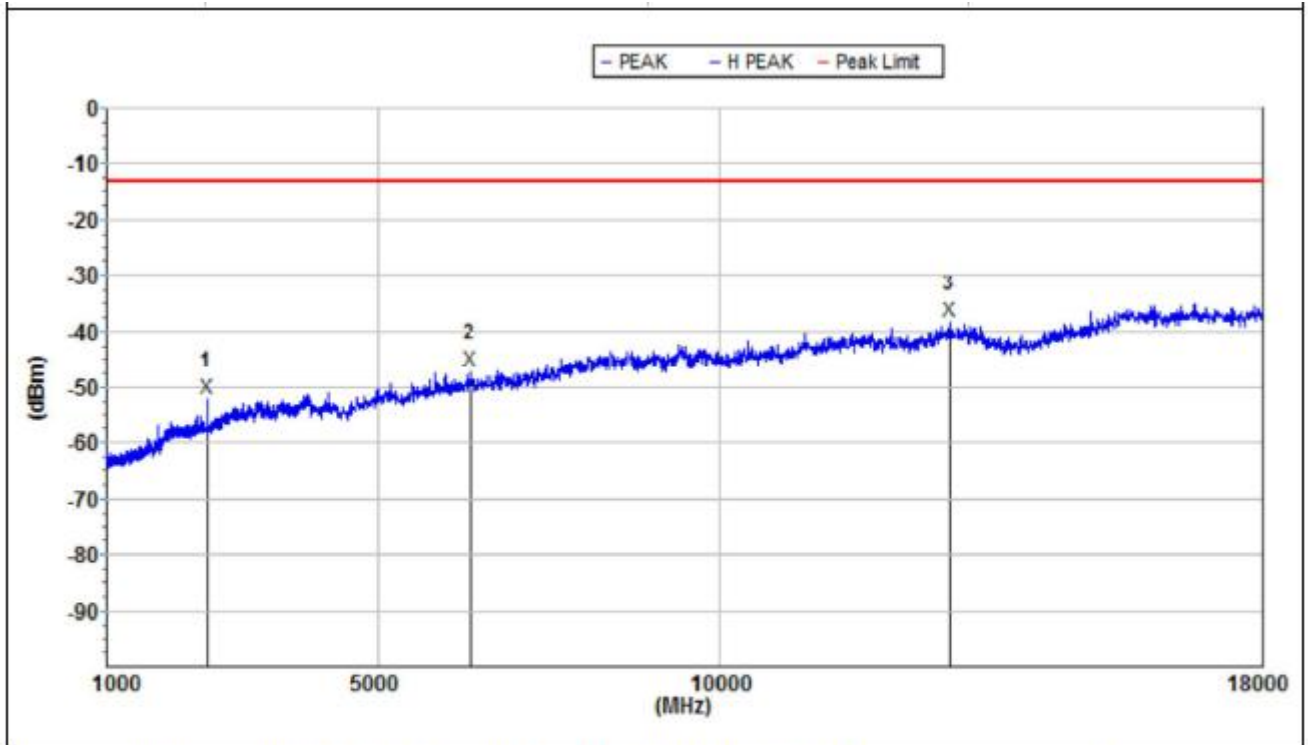
**Horizontal**
**1000MHz -4000MHz**

Mk.	Freq.(MHz)	Level(dBm)	Limit(dBm)	Margin(dB)	Deg.(deg.)	Hi(cm)	Factor(dB)	Pol.
Peak:								
1	2500.000	-51.9	-13.0	38.9	223.8	150	-11.6	H
2	6359.000	-47.2	-13.0	34.2	359.7	150	0.7	H
3	13415.000	-38.0	-13.0	25.0	359.7	150	9.6	H

Test Mode

Band 4\_Traffic Mode\_Low CH\_Main antenna

Vertical

1000MHz -4000MHz

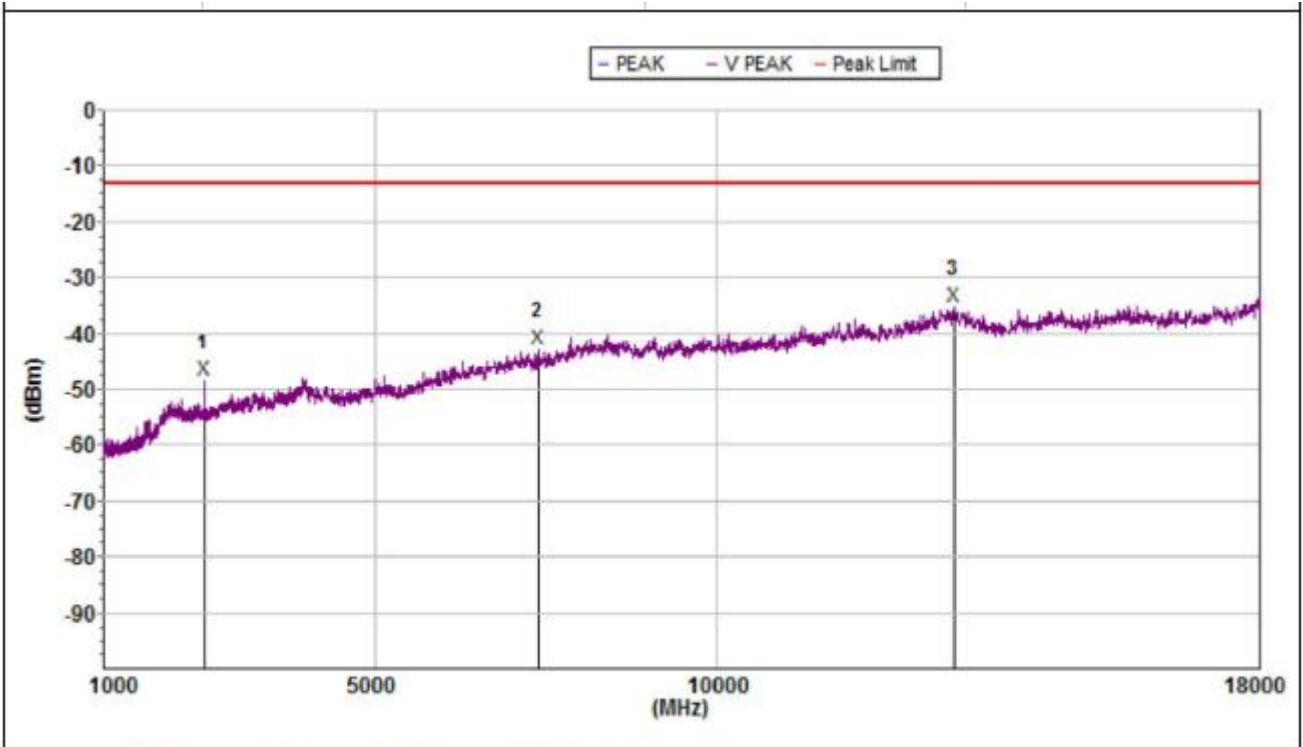

Mk.	Freq. (MHz)	Level(dBm)	Limit(dBm)	Margin(dB)	De (dB)	Hi (cm)	Factor(dB)	Pol.
Peak:								
1	2500.000	-48.4	-13.0	35.4	183.6	150	-9.0	V
2	7402.000	-42.7	-13.0	29.7	0.2	150	4.9	V
3	13499.000	-35.1	-13.0	22.1	0.2	150	13.5	V

Test Mode

Band 5\_Traffic Mode\_High CH\_Main antenna

**Horizontal**

30MHz -1000MHz

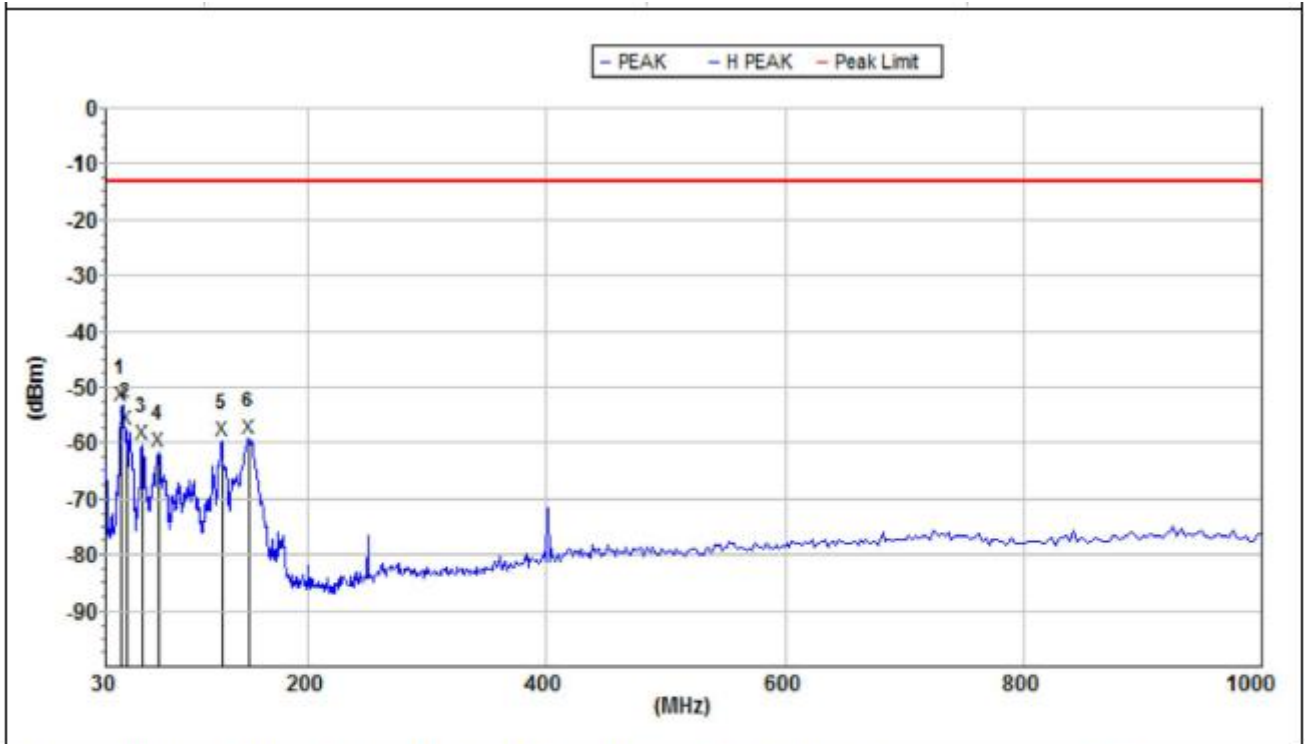

Mk	Freq.(MHz)	Level(dBm)	Limit(dBm)	Margin(dB)	De (+)	Hi(cm)	Factor(dB)	Pol.
Peak:								
1	44.120	-53.2	-13.0	40.2	24.9	150	-34.9	H
2	48.163	-57.6	-13.0	44.6	251.1	150	-34.0	H
3	60.704	-60.3	-13.0	47.3	106.3	150	-31.1	H
4	74.919	-61.6	-13.0	48.6	276.1	150	-28.3	H
5	127.665	-59.6	-13.0	46.6	282.4	150	-23.1	H
6	150.011	-59.2	-13.0	46.2	169.3	150	-22.6	H

Test Mode

Band 5\_Traffic Mode\_High CH\_Main antenna

Vertical

30MHz -1000MHz

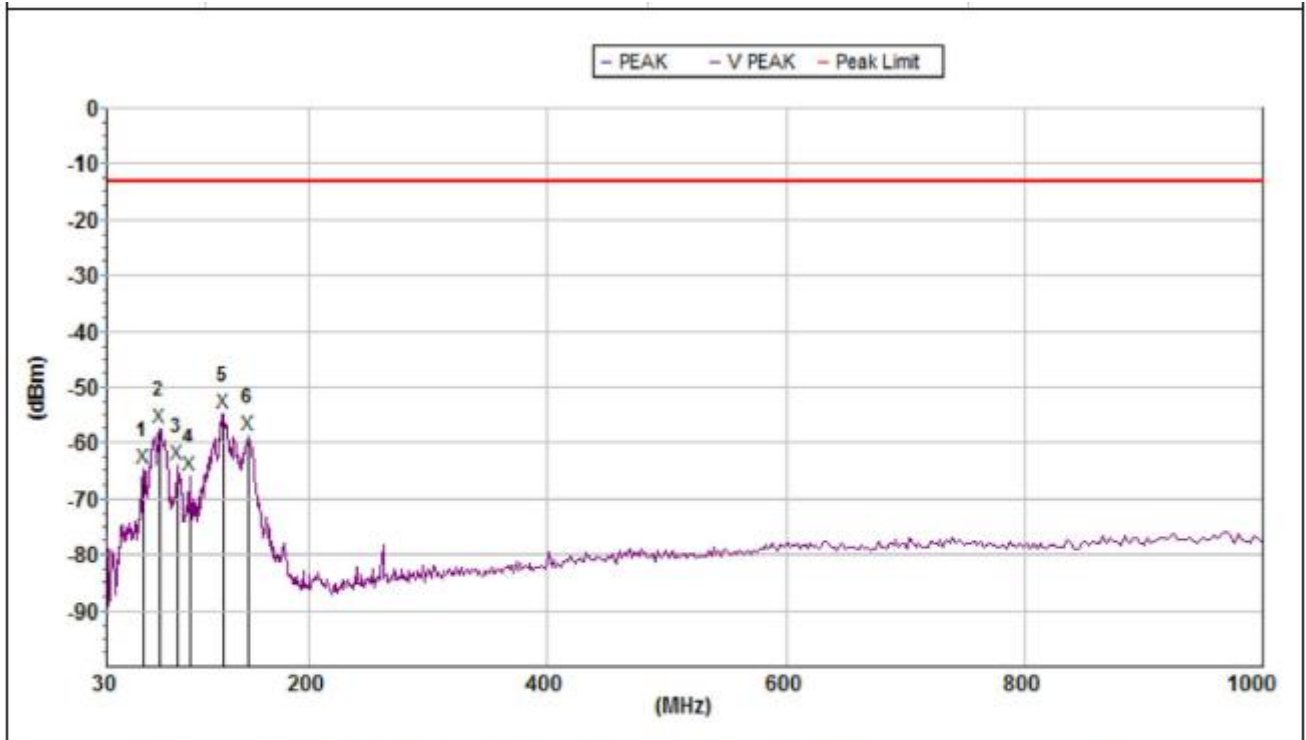

Mk	Freq (MHz)	Level (dBm)	Limit (dBm)	Margin (dB)	De (+)	Hi (cm)	Factor (dB)	Pol.
Peak:								
1	61.995	-64.6	-13.0	51.6	83.6	150	-31.9	V
2	74.919	-57.3	-13.0	44.3	309.9	150	-28.0	V
3	89.905	-63.9	-13.0	50.9	360	150	-25.3	V
4	99.528	-65.8	-13.0	52.8	184.2	150	-23.6	V
5	127.665	-54.6	-13.0	41.6	27	150	-20.3	V
6	149.486	-58.7	-13.0	45.7	278.4	150	-21.4	V

Test Mode

Band 5\_Traffic Mode\_High CH\_Main antenna

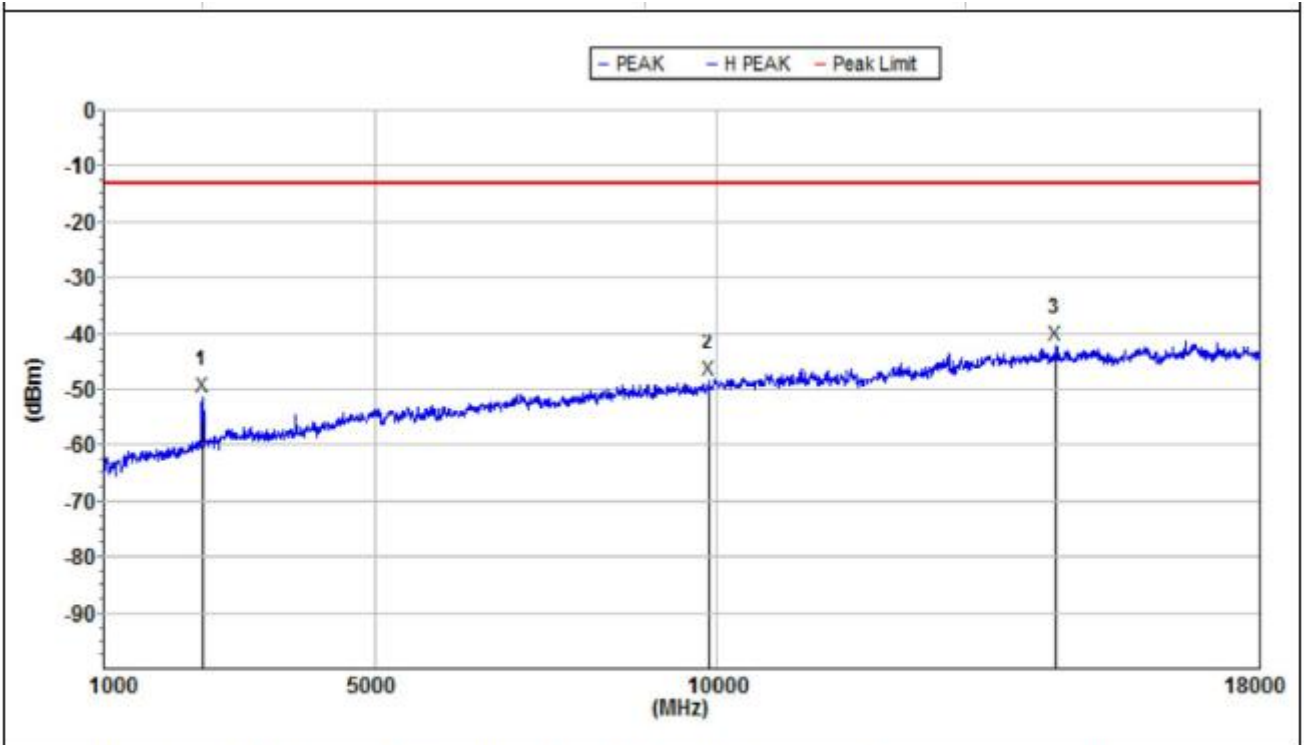
**Horizontal**
**1000MHz -4000MHz**

Mk	Freq (MHz)	Level(dBm)	Limit(dBm)	Margin(dB)	Deg.(deg.)	Hi(cm)	Factor(dB)	Pol.
Peak:								
1	2462.000	-51.4	-13.0	38.4	176.72	150	33.1	H
2	9908.000	-48.4	-13.0	35.4	360	150	4.9	H
3	14999.500	-42.1	-13.0	29.1	359.31	150	9.5	H

Test Mode

Band 5\_Traffic Mode\_High CH\_Main antenna

Vertical

1000MHz -4000MHz

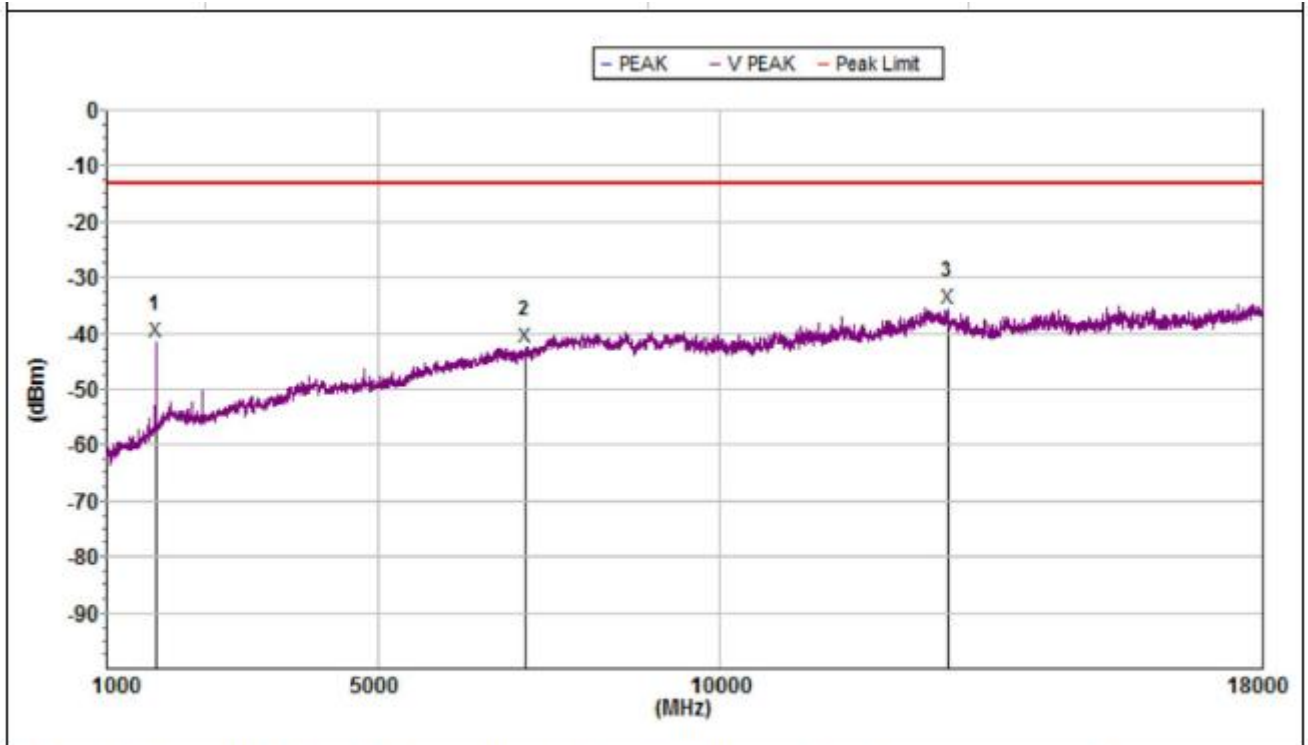

Mk.	Freq.(MHz)	Level(dBm)	Limit(dBm)	Margin(dB)	Deg.(deg.)	HI(cm)	Factor(dB)	Pol.
Peak:								
1	1726.750	-41.3	-13.0	28.3	319.62	150	36.5	V
2	7166.750	-42.5	-13.0	29.5	103.92	150	4.6	V
3	13380.250	-35.4	-13.0	22.4	359.43	150	13.0	V

Test Mode

Band 5\_Traffic Mode\_Mid CH\_Main antenna

**Horizontal**

30MHz -1000MHz

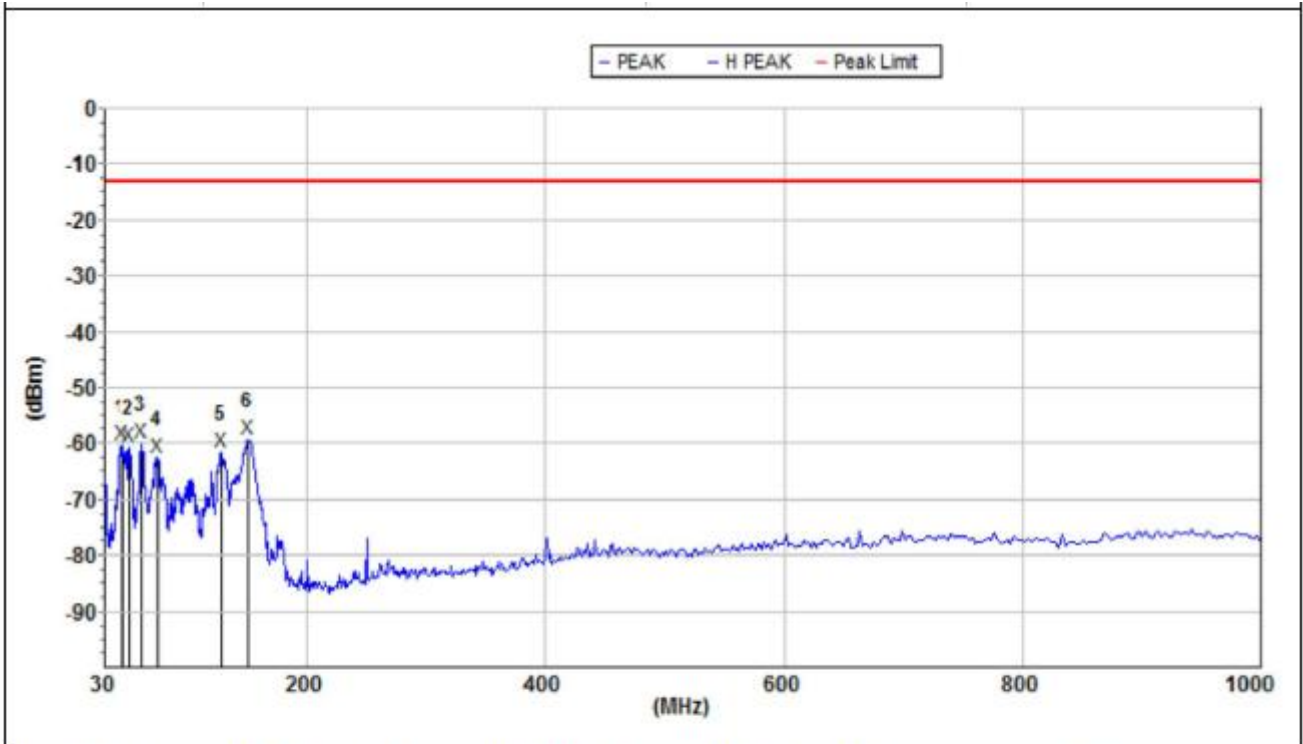

Mk.	Freq.(MHz)	Level(dBm)	Limit(dBm)	Margin(dB)	De <input type="text" value="+"/>	Hi(cm)	Factor(dB)	Pol.
Peak:								
1	44.431	-60.2	-13.0	47.2	359.2	150	-34.8	H
2	50.409	-60.6	-13.0	47.6	356.1	150	-33.4	H
3	61.346	-59.8	-13.0	46.8	338.1	150	-30.9	H
4	74.396	-62.4	-13.0	49.4	0	150	-28.4	H
5	127.665	-61.6	-13.0	48.6	212.6	150	-23.1	H
6	151.067	-59.1	-13.0	46.1	74.8	150	-22.6	H

Test Mode

Band 5\_Traffic Mode\_Mid CH\_Main antenna

Vertical

30MHz -1000MHz

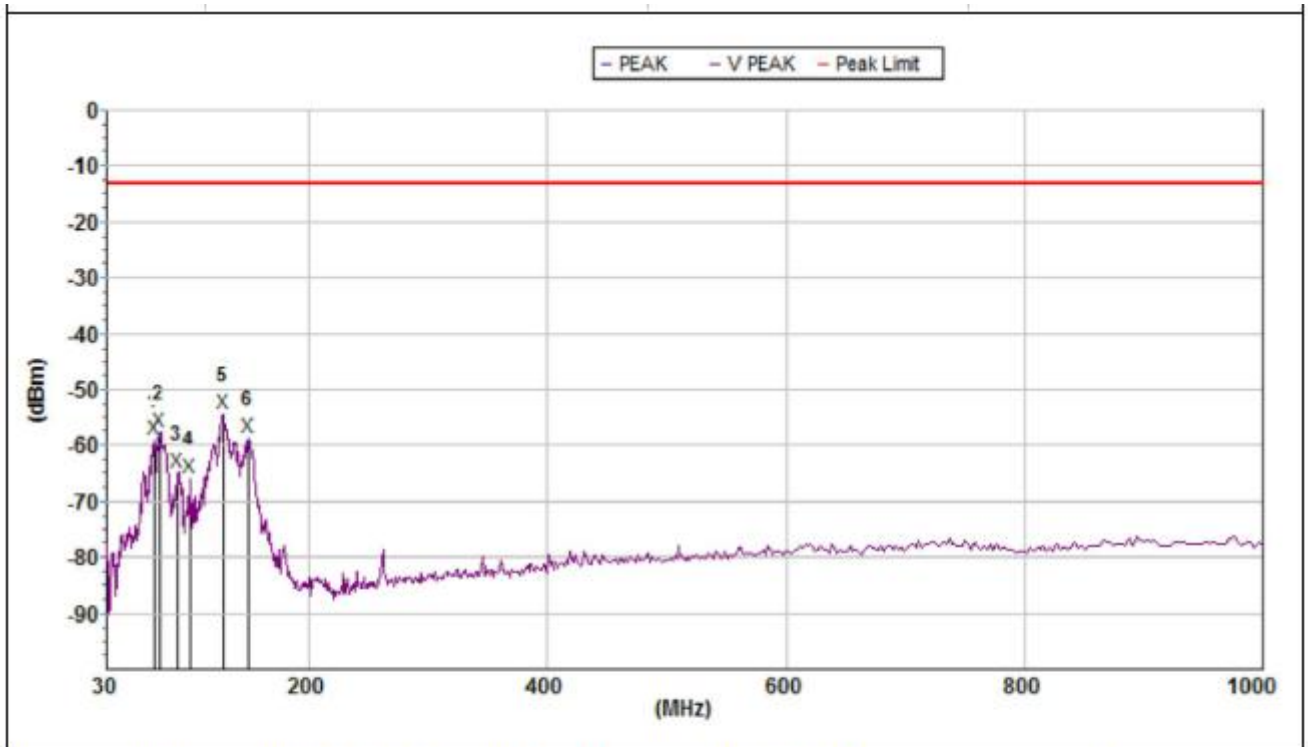

Mk.	Freq.(MHz)	Level(dBm)	Limit(dBm)	Margin(dB)	De (+)	Hi.(cm)	Factor(dB)	Pol.
Peak:								
1	70.832	-58.8	-13.0	45.8	0.6	150	-28.8	V
2	74.919	-57.7	-13.0	44.7	134.1	150	-28.0	V
3	89.905	-64.7	-13.0	51.7	360	150	-25.3	V
4	99.528	-65.7	-13.0	52.7	259.6	150	-23.6	V
5	127.665	-54.4	-13.0	41.4	0.6	150	-20.3	V
6	149.486	-58.5	-13.0	45.5	303.5	150	-21.4	V

Test Mode

Band 5\_Traffic Mode\_Mid CH\_Main antenna

## Horizontal

1000MHz -4000MHz

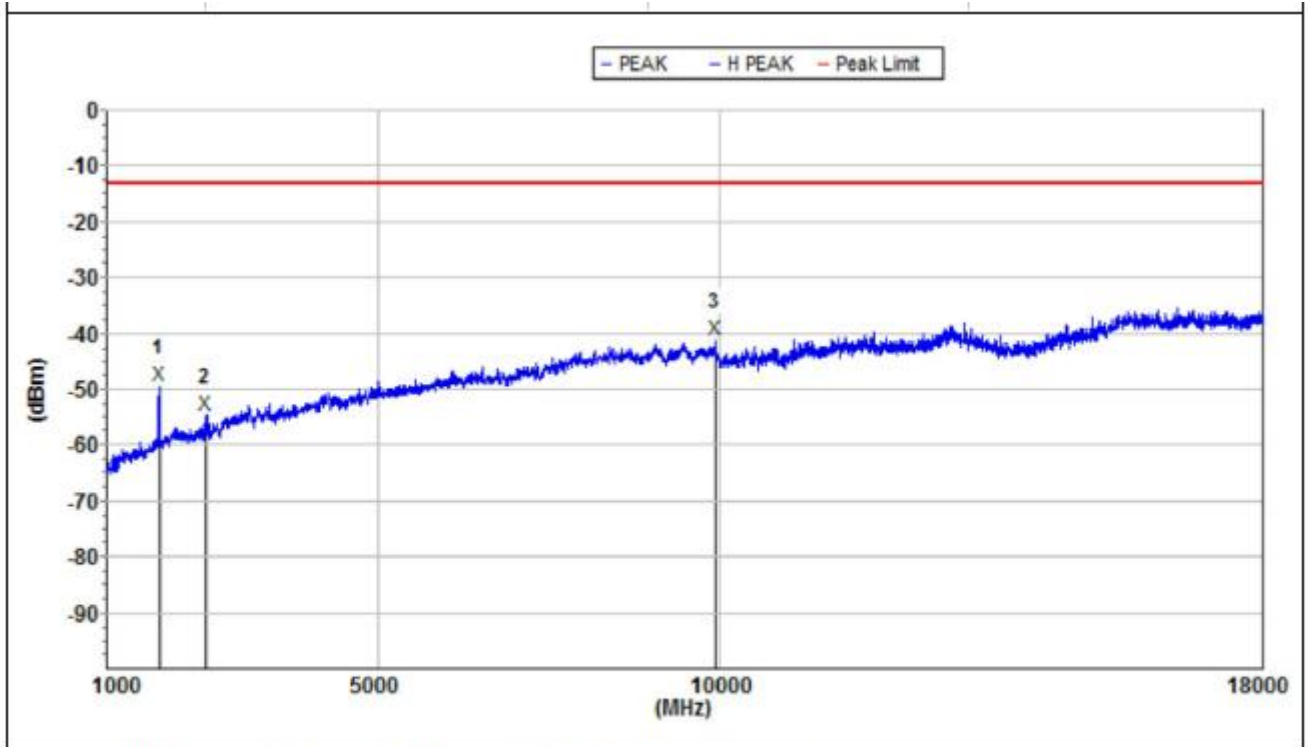

Mk.	Freq.(MHz)	Level(dBm)	Limit(dBm)	Margin(dB)	Deg.(deg.)	Hi.(cm)	Factor(dB)	Pol.
Peak:								
1	1778.500	-49.2	-13.0	36.2	327.7	150	-13.1	H
2	2453.500	-54.5	-13.0	41.5	360	150	-11.8	H
3	9946.000	-41.2	-13.0	28.2	228.8	150	4.8	H

Test Mode

Band 5\_Traffic Mode\_Mid CH\_Main antenna

Vertical

1000MHz -4000MHz

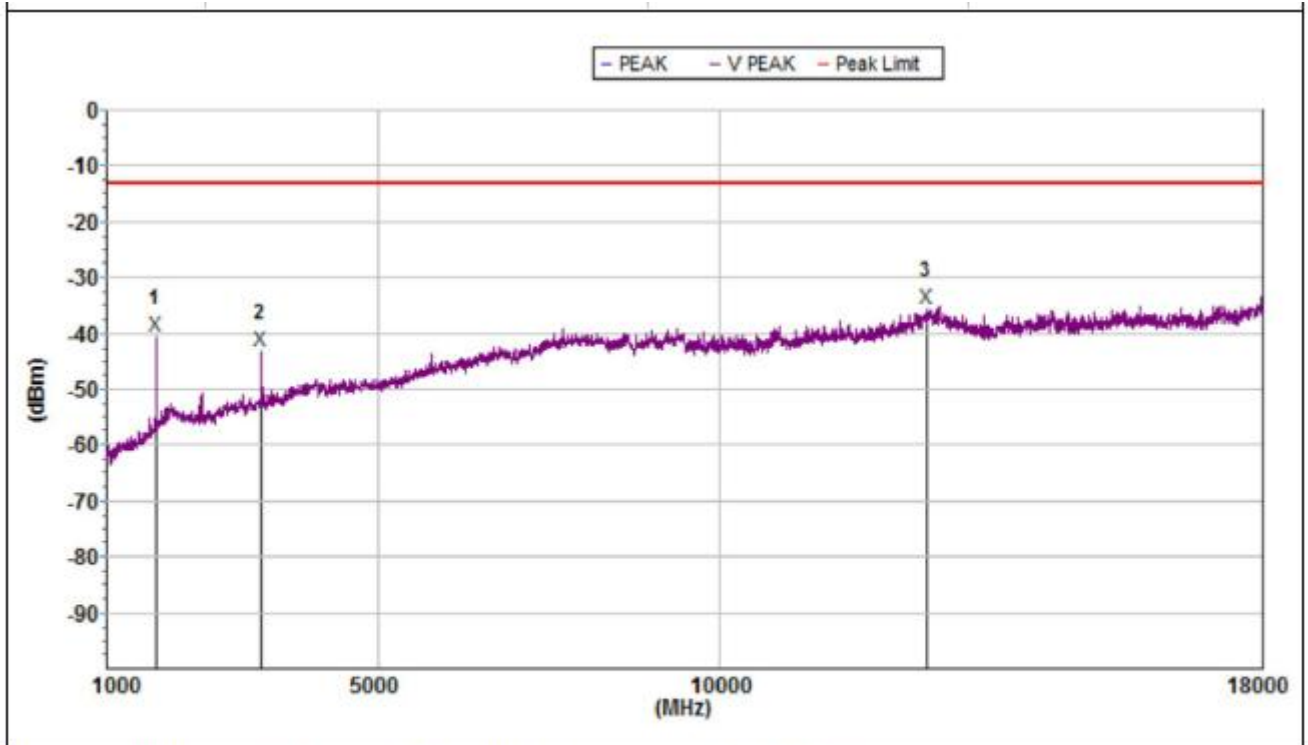

Mk	Freq (MHz)	Level (dBm)	Limit (dBm)	Margin (dB)	De (cm)	Hi (cm)	Factor (dB)	Pol.
Peak:								
1	1722.500	-40.6	-13.0	27.6	76.47	150	36.6	V
2	3273.750	-43.1	-13.0	30.1	193.02	150	-5.8	V
3	13070.000	-35.5	-13.0	22.5	359.31	150	11.7	V

Test Mode

Band 5\_Traffic Mode\_Low CH\_Main antenna

Horizontal

30MHz -1000MHz

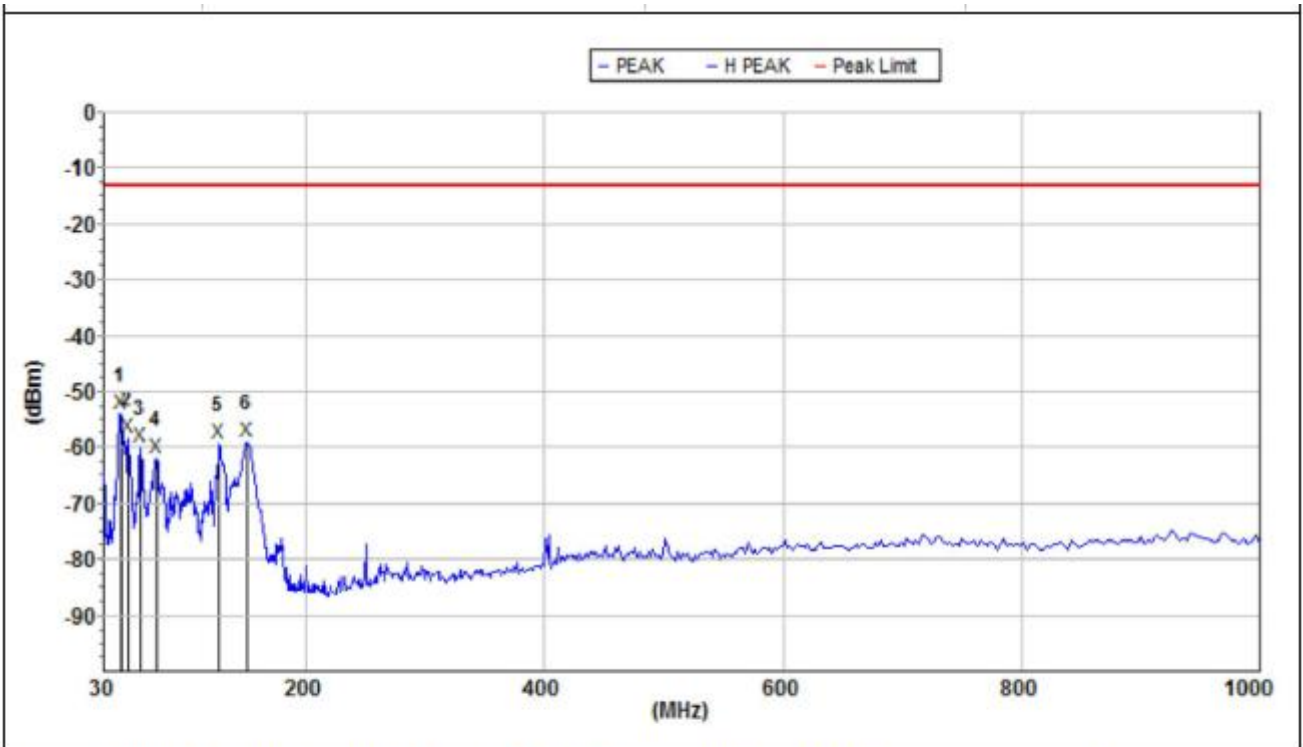

Mk.	Freq.(MHz)	Level(dBm)	Limit(dBm)	Margin(dB)	De (+)	Hi(cm)	Factor(dB)	Pol.
Peak:								
1	44.431	-53.9	-13.0	40.9	162.5	150	-34.8	H
2	50.409	-58.1	-13.0	45.1	193.7	150	-33.4	H
3	61.132	-60.0	-13.0	47.0	274.4	150	-31.0	H
4	74.657	-61.7	-13.0	48.7	6.4	150	-28.4	H
5	127.218	-59.3	-13.0	46.3	343.3	150	-23.1	H
6	150.538	-58.8	-13.0	45.8	162.5	150	-22.6	H

Test Mode

Band 5\_Traffic Mode\_Low CH\_Main antenna

Vertical

30MHz -1000MHz

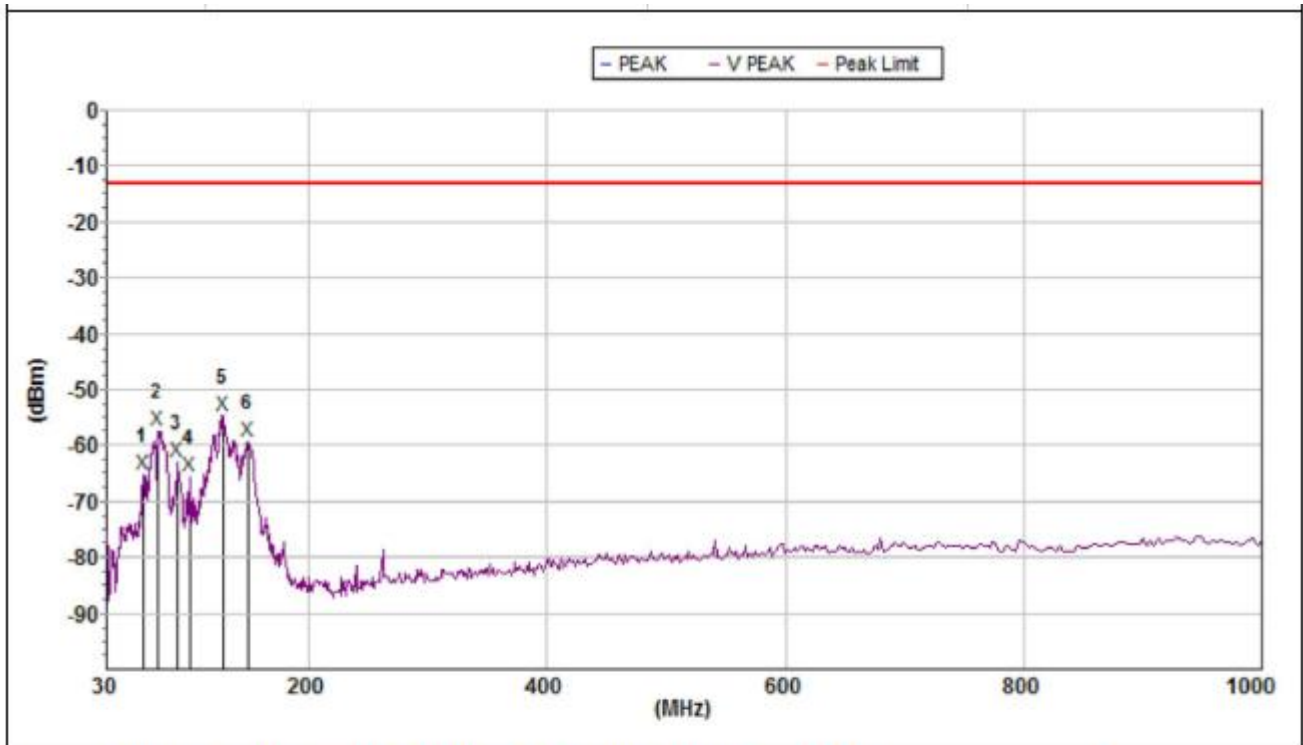

Mk.	Freq.(MHz)	Level(dBm)	Limit(dBm)	Margin(dB)	Deg.(deg.)	Hi.(cm)	Factor(dB)	Pol.
Peak:								
1	61.562	-65.0	-13.0	52.0	341.4	150	-32.0	V
2	73.617	-57.1	-13.0	44.1	360	150	-28.2	V
3	89.905	-62.9	-13.0	49.9	196.9	150	-25.3	V
4	99.528	-65.6	-13.0	52.6	357.9	150	-23.6	V
5	127.665	-54.5	-13.0	41.5	40.1	150	-20.3	V
6	149.486	-59.3	-13.0	46.3	109	150	-21.4	V

Test Mode

Band 5\_Traffic Mode\_Low CH\_Main antenna

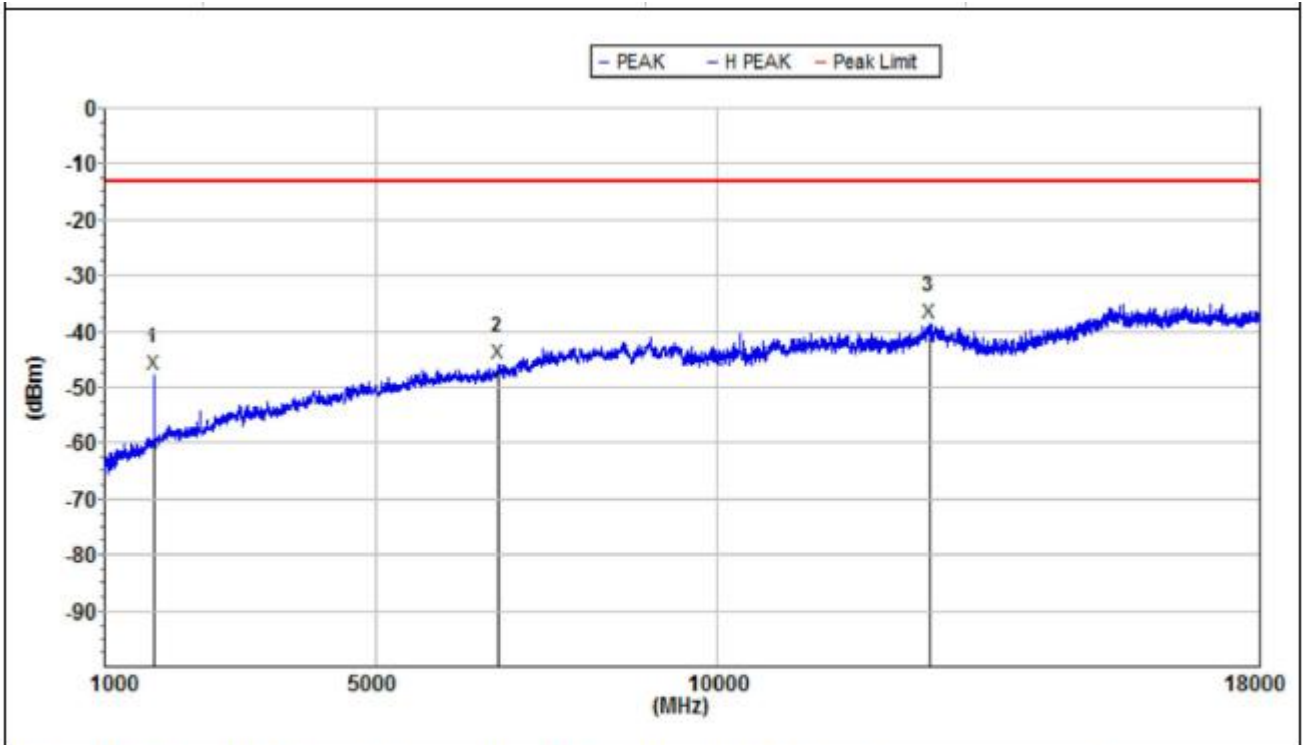
**Horizontal**
**1000MHz -4000MHz**

Mk.	Freq (MHz)	Level(dBm)	Limit(dBm)	Margin(dB)	Deg.(deg.)	Hi(cm)	Factor(dB)	Pol.
Peak:								
1	1722.500	-47.6	-13.0	34.6	5.51	150	33.8	H
2	6788.500	-45.8	-13.0	32.8	166.82	150	0.8	H
3	13150.750	-38.6	-13.0	25.6	0.6	150	8.5	H

Test Mode

Band 5\_Traffic Mode\_Low CH\_Main antenna

Vertical

1000MHz -4000MHz

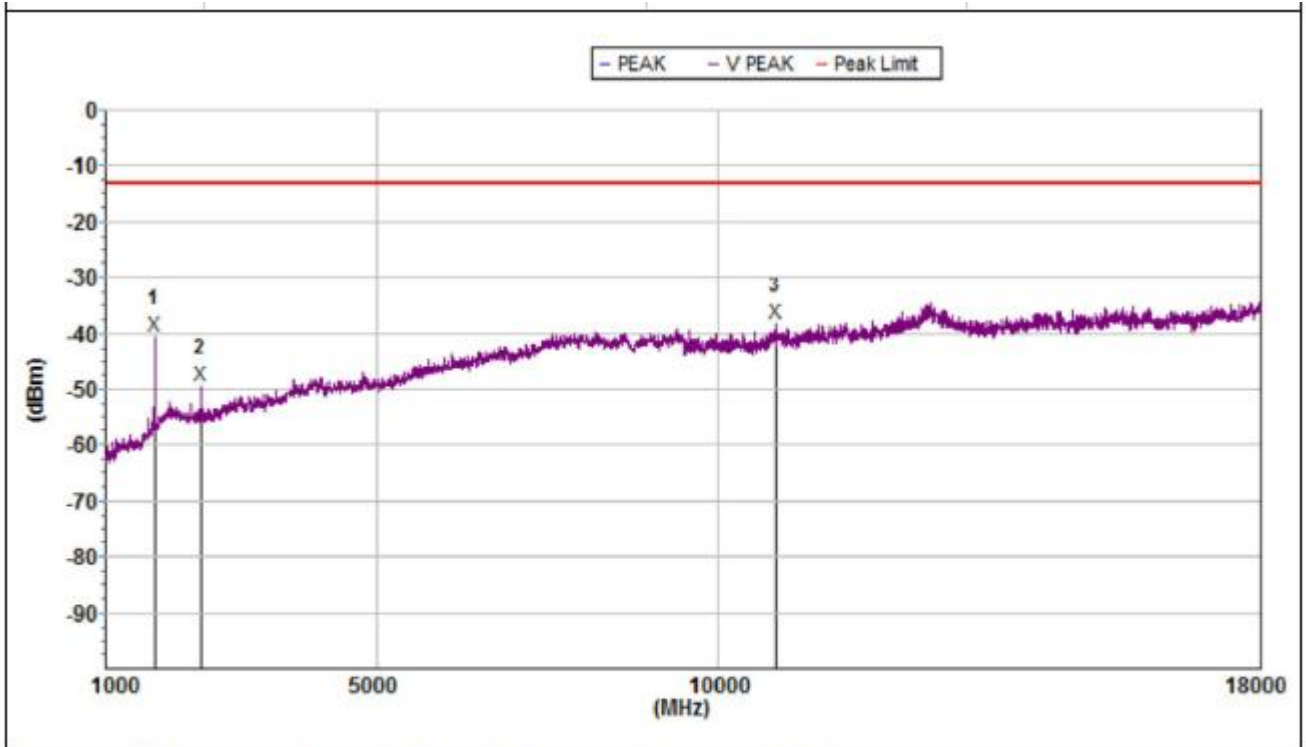

Mk	Freq (MHz)	Level (dBm)	Limit (dBm)	Margin (dB)	Deg. (deg.)	Hi (cm)	Factor (dB)	Pol.
Peak:								
1	1722.500	-40.3	-13.0	27.3	23.77	150	36.6	V
2	2415.250	-49.3	-13.0	36.3	228.87	150	36.1	V
3	10860.000	-38.2	-13.0	25.2	359.86	150	8.3	V

#### **4. TEST SETUP PHOTOGRAPHS**

Please refer to the Appendix F.

#### **5. EXTERNAL AND INTERNAL PHOTOS OF THE EUT**

External Please refer to the Appendix G.

Internal Please refer to the Appendix H.

※※※※END OF THE REPORT※※※※※