



RF TEST REPORT

Report No.: SZ25080340W02

Applicant : D-Link Corporation

Product Name : 4G LTE AX300 Wi-Fi 6 USB Adapter

Brand Name : D-LINK

Model Name : DWM-222W

Series Model : DWM-222W/x, DWM-222W/xx, DWM-222W/xxx
(x can be 0-9 , A-Z)

FCC ID : KA2WM222WB1

Test Standard : 47 CFR Part 2;47 CFR Part 22;47 CFR Part 24;
47 CFR Part 27;

Date of Sample Arrival : 2025.07.21

Date of Test : 2025.07.21-2025.09.24

Issue Date : 2025.09.24

Edited by:

Zeng Xiaoying (Rapporteur)

Approved by:

Shen Junsheng (Supervisor)

NOTE: This document is issued by ShenzhenMorlab Communications Technology Co., Ltd., the test report shall not be reproduced except in full without prior written permission of the company. The test results apply only to the particular sample(s) tested and to the specific tests carried out which is available on request for validation and information confirmed at our website.



TABLE OF CONTENTS

REVISION HISTORY	3
DECLARATION OF REPORT	4
SUMMARY OF TEST RESULT	5
1. GENERAL DESCRIPTION	10
1.1. Applicant	10
1.2. Manufacturer	10
1.3. Factory	10
1.4. General Information of EUT	11
1.5. Equipment Specification	12
1.6. Maximum Conducted Power and Emission Designator	13
1.7. Modification of EUT	14
1.8. Laboratory Information	15
1.9. Applicable Standards	15
1.10. Environmental conditions	15
2. TEST CONFIGURATION OF EQUIPMENT UNDER TEST	16
2.1. Test Mode	16
2.2. Connection Diagram of Test System	18
2.3. Support Unit used in test configuration and system	18
2.4. Frequency List of Low/Middle/High Channels	19
2.5. Equipment List	22
2.6. Measurement Uncertainty	24
3. TEST RESULT	25
3.1. Conducted Output Power and ERP/EIRP	25
3.2. Peak-to-Average Ratio	26
3.3. Occupied Bandwidth	27
3.4. Conducted Band Edge	29
3.5. Conducted Spurious Emission	32
3.6. Frequency Stability	33
3.7. Radiated Spurious Emission	35
Radiated spurious emissions - MS allocated a channel:	37
4. TEST SETUP PHOTOGRAPHS	87
5. EXTERNAL AND INTERNAL PHOTOS OF THE EUT	87

NOTE: This document is issued by Shenzhen Morlab Communications Technology Co., Ltd., the test report shall not be reproduced except in full without prior written permission of the company. The test results apply only to the particular sample(s) tested and to the specific tests carried out which is available on request for validation and information confirmed at our website.



REVISION HISTORY

Rev.	Issue Date	Revisions	Revised by
00	2025.09.24	Initial Release	Guozheng Li

NOTE: This document is issued by Shenzhen Morlab Communications Technology Co., Ltd., the test report shall not be reproduced except in full without prior written permission of the company. The test results apply only to the particular sample(s) tested and to the specific tests carried out which is available on request for validation and information confirmed at our website.



DECLARATION OF REPORT

1. The device has been tested by Morlab, and the test results show that the equipment under test (EUT) is in compliance with the requirements of 47 CFR Part 2;47 CFR Part 22;47 CFR Part 24; 47 CFR Part 27;. And it is applicable only to the tested sample identified in the report.

2. This report shall not be reproduced except in full, without the written approval of Morlab, this document only be altered or revised by Morlab, personal only, and shall be noted in the revision of the document.

3. The general information of EUT in this report is provided by the customer or manufacture, Morlab is only responsible for the test data but not for the information provided by the customer or manufacture.

4. The results in this report is only apply to the sample as tested under conditions. The customer or manufacturer is responsible for ensuring that the additional production units of this model have the same electrical and mechanical components.

NOTE: This document is issued by Shenzhen Morlab Communications Technology Co., Ltd., the test report shall not be reproduced except in full without prior written permission of the company. The test results apply only to the particular sample(s) tested and to the specific tests carried out which is available on request for validation and information confirmed at our website.



SUMMARY OF TEST RESULT

For Band2

Test Item	FCC Rule No.	Limit	Result	Verdict (Note1)
Effective (Isotropic) Radiated Power Output Data	Part 24.232	EIRP \leq 2 W	Pass	Appendix C1
Peak-Average Ratio	Part 2.1046, 24.232	Limit \leq 13 dB	Pass	Appendix C2
Frequency Stability	Part 2.1055, 24.235	$\leq \pm 2.5$ ppm.	Pass	Appendix C3
Occupied Bandwidth	Part 2.1049	OBW: No limit. EBW: No limit.	Pass	Appendix C4
Spurious Emission at Antenna Terminals	Part 2.1051, 24.238	≤ -13 dBm/1 MHz, from 9 kHz to 10 th harmonics but outside authorized operating frequency ranges.	Pass	Appendix C5
Band Edges Compliance	Part 2.1051, 24.238	≤ -13 dBm/1%*EBW, in 1 MHz bands immediately outside and adjacent to the frequency block.	Pass	Appendix C6
Modulation Characteristics	Part 2.1047	Digital modulation	Pass	Appendix C7
Radiated Spurious Emissions	Part 2.1053, 24.238	≤ -13 dBm/1 MHz.	Pass	/
Note1: For the verdict, the "N/A" denotes "not applicable", the "N/T" denotes "not tested".				

NOTE: This document is issued by Shenzhen Morlab Communications Technology Co., Ltd., the test report shall not be reproduced except in full without prior written permission of the company. The test results apply only to the particular sample(s) tested and to the specific tests carried out which is available on request for validation and information confirmed at our website.



For Band4 and LTE Band66

Test Item	FCC Rule No.	Limit	Result	Verdict (Note1)
Effective (Isotropic) Radiated Power Output Data	Part 27.50(d)	$EIRP \leq 1\text{ W}$	Pass	Appendix C1
Peak-Average Ratio	Part 2.1046, 27.50(d)	Limit $\leq 13\text{ dB}$	Pass	Appendix C2
Frequency Stability	Part 2.1055, 27.54	$\leq \pm 2.5\text{ ppm.}$	Pass	Appendix C3
Occupied Bandwidth	Part 2.1049	OBW: No limit. EBW: No limit.	Pass	Appendix C4
Spurious Emission at Antenna Terminals	Part 2.1051, 27.53(h)	$\leq -13\text{ dBm/1 MHz}$, from 9 kHz to 10 th harmonics but outside authorized operating frequency ranges.	Pass	Appendix C5
Band Edges Compliance	Part 2.1051, 27.53(h)	$\leq -13\text{ dBm/1\%*EBW}$, in 1 MHz bands immediately outside and adjacent to the frequency block.	Pass	Appendix C6
Modulation Characteristics	Part 2.1047	Digital modulation	Pass	Appendix C7
Radiated Spurious Emissions	Part 2.1053, 27.53(h)	$\leq -13\text{ dBm/1 MHz.}$	Pass	/

Note1:

For the verdict, the "N/A" denotes "not applicable", the "N/T" denotes "not tested".

NOTE: This document is issued by Shenzhen Morlab Communications Technology Co., Ltd., the test report shall not be reproduced except in full without prior written permission of the company. The test results apply only to the particular sample(s) tested and to the specific tests carried out which is available on request for validation and information confirmed at our website.



For Band5

Test Item	FCC Rule No.	Limit	Result	Verdict (Note1)
Effective (Isotropic) Radiated Power Output Data	Part 22.913 (a)	ERP \leq 7 W	Pass	Appendix C1
Peak-Average Ratio	Part 2.1046, 22.913 (a)	Limit \leq 13 dB	Pass	Appendix C2
Frequency Stability	Part 2.1055, 22.355	$\leq \pm 2.5$ ppm.	Pass	Appendix C3
Occupied Bandwidth	Part 2.1049	OBW: No limit. EBW: No limit.	Pass	Appendix C4
Spurious Emission at Antenna Terminals	Part 2.1051, 22.917	≤ -13 dBm/1 MHz, from 9 kHz to 10 th harmonics but outside authorized operating frequency ranges.	Pass	Appendix C5
Band Edges Compliance	Part 22.917	≤ -13 dBm/1%*EBW, in 1 MHz bands immediately outside and adjacent to the frequency block.	Pass	Appendix C6
Modulation Characteristics	Part 2.1047	Digital modulation	Pass	Appendix C7
Radiated Spurious Emissions	Part 2.1053, 22.917	≤ -13 dBm/1 MHz.	Pass	/

Note1:

For the verdict, the "N/A" denotes "not applicable", the "N/T" denotes "not tested".

NOTE: This document is issued by Shenzhen Morlab Communications Technology Co., Ltd., the test report shall not be reproduced except in full without prior written permission of the company. The test results apply only to the particular sample(s) tested and to the specific tests carried out which is available on request for validation and information confirmed at our website.

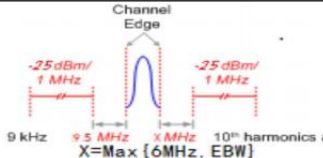

For Band7 and Band41

Test Item	FCC Rule No.	Limit	Result	Verdict (Note1)
Effective (Isotropic) Radiated Power Output Data	Part 27.50(h)	EIRP ≤ 2 W	Pass	Appendix C1
Peak-Average Ratio	Part 2.1046 27.50(h)	Limit≤13 dB	Pass	Appendix C2
Frequency Stability	Part 2.1055, 27.54	≤ ± 2.5 ppm.	Pass	Appendix C3
Occupied Bandwidth	Part 2.1049	OBW: No limit. EBW: No limit.	Pass	Appendix C4
Spurious Emission at Antenna Terminals	Part 2.1051, 27.53(m)		Pass	Appendix C5
Band Edges Compliance	Part 2.1051, 27.53(m4)	<p>For mobile digital stations, the attenuation factor shall be not less than 40 + 10 log (P) dB on all frequencies between the channel edge and 5 megahertz from the channel edge, 43 + 10 log (P) dB on all frequencies between 5 megahertz and X megahertz from the channel edge, and 55 + 10 log (P) dB on all frequencies more than X megahertz from the channel edge, where X is the greater of 6 megahertz or the actual emission bandwidth as defined in paragraph (m)(6) of this section.</p>	Pass	Appendix C6
Modulation Characteristics	Part 2.1047	Digital modulation	Pass	Appendix C7
Radiated Spurious Emissions	Part 2.1053, 27.53(m)	≤ -25 dBm/1 MHz.	Pass	/
<p>Note1: For the verdict, the “N/A” denotes “not applicable”, the “N/T” denotes “not tested”.</p>				

NOTE: This document is issued by Shenzhen Morlab Communications Technology Co., Ltd., the test report shall not be reproduced except in full without prior written permission of the company. The test results apply only to the particular sample(s) tested and to the specific tests carried out which is available on request for validation and information confirmed at our website.



For Band12 and Bnad17

Test Item	FCC Rule No.	Limit	Result	Verdict (Note1)
Effective (Isotropic) Radiated Power Output Data	Part 27.50(c)	ERP ≤ 3 W	Pass	Appendix C1
Peak-Average Ratio	Part 2.1046, Part 27.50(c)	Limit ≤ 13 dB	Pass	Appendix C2
Frequency Stability	Part 2.1055, 27.54	≤ ± 2.5 ppm.	Pass	Appendix C3
Occupied Bandwidth	Part 2.1049	OBW: No limit. EBW: No limit.	Pass	Appendix C4
Spurious Emission at Antenna Terminals	Part 2.1051, 27.53(g)	≤ -13 dBm/100 kHz, from 9 kHz to 10 th harmonics but outside authorized operating frequency ranges.	Pass	Appendix C5
Band Edges Compliance	Part 2.1051, 27.53(g)	≤ -13 dBm/1%*EBW, in 1 MHz bands immediately outside and adjacent to the frequency block.	Pass	Appendix C6
Modulation Characteristics	Part 2.1047	Digital modulation	Pass	Appendix C7
Radiated Spurious Emissions	Part 2.1053, 27.53(g)	≤ -13 dBm/1 MHz.	Pass	/
Note1: For the verdict, the "N/A" denotes "not applicable", the "N/T" denotes "not tested".				

NOTE: This document is issued by Shenzhen Morlab Communications Technology Co., Ltd., the test report shall not be reproduced except in full without prior written permission of the company. The test results apply only to the particular sample(s) tested and to the specific tests carried out which is available on request for validation and information confirmed at our website.



1. GENERAL DESCRIPTION

1.1. Applicant

Name : D-Link Corporation

Address : 14420 Myford Road Suite 100, Irvine, California 92606, United States

1.2. Manufacturer

Name : D-Link Corporation

Address : 14420 Myford Road Suite 100, Irvine, California 92606, United States

1.3. Factory

Name : AMIT Wireless Inc.

Address : No. 82, Gongye 2nd Rd., Annan Dist., Tainan City 709015, Taiwan, China

NOTE: This document is issued by Shenzhen Morlab Communications Technology Co., Ltd., the test report shall not be reproduced except in full without prior written permission of the company. The test results apply only to the particular sample(s) tested and to the specific tests carried out which is available on request for validation and information confirmed at our website.



1.4. General Information of EUT

General Information	
Equipment Name	4G LTE AX300 Wi-Fi 6 USB Adapter
Brand Name	D-LINK
Model Name	DWM-222W
Series Model	DWM-222W/x, DWM-222W/xx, DWM-222W/xxx (x can be 0-9 , A-Z)
Model Difference	Only model name and color are different
Test Sample	202503100007001
Power Supply:	Input:DC 5V
Adapter	/
Battery	/
Hardware Version	B1
Software Version	1.00.09LA
Connecting I/O Port(s)	Refer to the remark below.

Remark:

The above information of EUT was declared by manufacturer. Please refer to the specifications or user's manual for more detailed description.

NOTE: This document is issued by Shenzhen Morlab Communications Technology Co., Ltd., the test report shall not be reproduced except in full without prior written permission of the company. The test results apply only to the particular sample(s) tested and to the specific tests carried out which is available on request for validation and information confirmed at our website.



1.5. Equipment Specification

Standards-related Product Specification		
Frequency		
Band	Tx Frequency Range	Rx Frequency Range
<input checked="" type="checkbox"/> Band 2	1850 MHz ~ 1910 MHz	1930 MHz ~ 1990 MHz
<input checked="" type="checkbox"/> Band 4	1710 MHz ~ 1755 MHz	2110 MHz ~ 2155 MHz
<input checked="" type="checkbox"/> Band 5	824 MHz ~ 849 MHz	869 MHz ~ 894 MHz
<input checked="" type="checkbox"/> Band 7	2500MHz ~ 2570MHz	2620MHz ~ 2690MHz
<input checked="" type="checkbox"/> Band 12	699 MHz ~ 716 MHz	728 MHz ~ 746 MHz
<input checked="" type="checkbox"/> Band 17	704 MHz ~ 716 MHz	734 MHz ~ 746 MHz
<input checked="" type="checkbox"/> Band 41	2496 MHz ~ 2690 MHz	2496 MHz ~ 2690 MHz
<input checked="" type="checkbox"/> Band 66	1710 MHz ~ 1780 MHz	2110 MHz~ 2200 MHz
Bandwidth		
Band	Bandwidth	
<input checked="" type="checkbox"/> Band 2	1.4MHz / 3MHz / 5MHz / 10MHz / 15MHz / 20MHz	
<input checked="" type="checkbox"/> Band 4	1.4MHz / 3MHz / 5MHz / 10MHz / 15MHz / 20MHz	
<input checked="" type="checkbox"/> Band 5	1.4MHz / 3MHz / 5MHz / 10MHz	
<input checked="" type="checkbox"/> Band 7	5MHz / 10MHz / 15MHz / 20MHz	
<input checked="" type="checkbox"/> Band 12	1.4MHz / 3MHz / 5MHz / 10MHz	
<input checked="" type="checkbox"/> Band 17	5MHz / 10MHz	
<input checked="" type="checkbox"/> Band 41	5MHz / 10MHz / 15MHz / 20MHz	
<input checked="" type="checkbox"/> Band 66	1.4MHz / 3MHz / 5MHz / 10MHz / 15MHz / 20MHz	
Antenna Gain		
Band	Antenna Gain	
<input checked="" type="checkbox"/> Band 2	2.25dbi	
<input checked="" type="checkbox"/> Band 4	1.38dbi	
<input checked="" type="checkbox"/> Band 5	2.23dbi	
<input checked="" type="checkbox"/> Band 7	2.61dbi	
<input checked="" type="checkbox"/> Band 12	-0.35dbi	
<input checked="" type="checkbox"/> Band 17	-0.35dbi	
<input checked="" type="checkbox"/> Band 41	2.61dbi	
<input checked="" type="checkbox"/> Band 66	1.56dbi	
Maximum Output Power to Antenna		
Band	Maximum Output Power	
<input checked="" type="checkbox"/> Band 2	27.76dBm	
<input checked="" type="checkbox"/> Band 4	26.99dBm	
<input checked="" type="checkbox"/> Band 5	24.54dBm	
<input checked="" type="checkbox"/> Band 7	26.08dBm	
<input checked="" type="checkbox"/> Band 12	23.81dBm	
<input checked="" type="checkbox"/> Band 17	23.49dBm	
<input checked="" type="checkbox"/> Band 41	26.74dBm	
<input checked="" type="checkbox"/> Band 66	26.39dBm	
Type of Modulation		
<input checked="" type="checkbox"/> QPSK	<input checked="" type="checkbox"/> 16QAM	<input type="checkbox"/> 64QAM <input type="checkbox"/> 256QAM

NOTE: This document is issued by Shenzhen Morlab Communications Technology Co., Ltd., the test report shall not be reproduced except in full without prior written permission of the company. The test results apply only to the particular sample(s) tested and to the specific tests carried out which is available on request for validation and information confirmed at our website.



1.6. Maximum Conducted Power and Emission Designator

<input checked="" type="checkbox"/> LTE Band 2				
Bandwidth (MHz)	QPSK		<input checked="" type="checkbox"/> 16QAM / <input type="checkbox"/> 64QAM / <input type="checkbox"/> 256QAM	
	Maximum Conducted Power (W)	Emission Designator (99% OBW)	Maximum Conducted power (W)	Emission Designator (99% OBW)
1.4	0.597	1M08G7D	0.457	1M08W7D
3	0.581	2M68G7D	0.472	2M68W7D
5	0.577	4M46G7D	0.476	4M47W7D
10	0.562	8M94G7D	0.465	8M93W7D
15	0.566	13M4G7D	0.459	13M4W7D
20	0.557	18M0G7D	0.478	18M0W7D
<input checked="" type="checkbox"/> LTE Band 4				
Bandwidth (MHz)	QPSK		<input checked="" type="checkbox"/> 16QAM / <input type="checkbox"/> 64QAM / <input type="checkbox"/> 256QAM	
	Maximum Conducted Power (W)	Emission Designator (99% OBW)	Maximum Conducted power (W)	Emission Designator (99% OBW)
1.4	0.475	1M08G7D	0.379	1M07W7D
3	0.479	2M69G7D	0.366	2M69W7D
5	0.492	4M47G7D	0.399	4M46W7D
10	0.500	8M94G7D	0.373	8M94W7D
15	0.500	13M4G7D	0.406	13M5W7D
20	0.491	18M0G7D	0.441	18M0W7D
<input checked="" type="checkbox"/> LTE Band 5				
Bandwidth (MHz)	QPSK		<input checked="" type="checkbox"/> 16QAM / <input type="checkbox"/> 64QAM / <input type="checkbox"/> 256QAM	
	Maximum Conducted Power (W)	Emission Designator (99% OBW)	Maximum Conducted power (W)	Emission Designator (99% OBW)
1.4	0.285	1M08G7D	0.236	1M08W7D
3	0.281	2M69G7D	0.248	2M68W7D
5	0.279	4M46G7D	0.237	4M47W7D
10	0.262	8M92G7D	0.230	8M94W7D
<input checked="" type="checkbox"/> LTE Band 7				
Bandwidth (MHz)	QPSK		<input checked="" type="checkbox"/> 16QAM / <input type="checkbox"/> 64QAM / <input type="checkbox"/> 256QAM	
	Maximum Conducted Power (W)	Emission Designator (99% OBW)	Maximum Conducted power (W)	Emission Designator (99% OBW)
5	0.389	4M50G7D	0.313	4M50W7D
10	0.406	8M97G7D	0.325	8M94W7D
15	0.403	13M5G7D	0.333	13M5W7D
20	0.401	18M0G7D	0.333	18M0W7D

NOTE: This document is issued by Shenzhen Morlab Communications Technology Co., Ltd., the test report shall not be reproduced except in full without prior written permission of the company. The test results apply only to the particular sample(s) tested and to the specific tests carried out which is available on request for validation and information confirmed at our website.



<input checked="" type="checkbox"/> LTE Band 12				
Bandwidth (MHz)	QPSK		<input checked="" type="checkbox"/> 16QAM / <input type="checkbox"/> 64QAM / <input type="checkbox"/> 256QAM	
	Maximum Conducted Power (W)	Emission Designator (99% OBW)	Maximum Conducted power (W)	Emission Designator (99% OBW)
1.4	0.207	1M08G7D	0.158	1M08W7D
3	0.205	2M69G7D	0.152	2M68W7D
5	0.240	4M47G7D	0.208	4M47W7D
10	0.227	8M94G7D	0.189	8M94W7D
<input checked="" type="checkbox"/> LTE Band 17				
Bandwidth (MHz)	QPSK		<input checked="" type="checkbox"/> 16QAM / <input type="checkbox"/> 64QAM / <input type="checkbox"/> 256QAM	
	Maximum Conducted Power (W)	Emission Designator (99% OBW)	Maximum Conducted power (W)	Emission Designator (99% OBW)
5	0.223	4M46G7D	0.184	4M47W7D
10	0.199	8M94G7D	0.167	8M89W7D
<input checked="" type="checkbox"/> LTE Band 41				
Bandwidth (MHz)	QPSK		<input checked="" type="checkbox"/> 16QAM / <input type="checkbox"/> 64QAM / <input type="checkbox"/> 256QAM	
	Maximum Conducted Power (W)	Emission Designator (99% OBW)	Maximum Conducted power (W)	Emission Designator (99% OBW)
5	0.472	4M46G7D	0.410	4M47W7D
10	0.464	8M92G7D	0.362	8M92W7D
15	0.468	13M4G7D	0.372	13M5W7D
20	0.470	18M0G7D	0.377	18M0W7D
<input checked="" type="checkbox"/> LTE Band 66				
Bandwidth (MHz)	QPSK		<input checked="" type="checkbox"/> 16QAM / <input type="checkbox"/> 64QAM / <input type="checkbox"/> 256QAM	
	Maximum Conducted Power (W)	Emission Designator (99% OBW)	Maximum Conducted power (W)	Emission Designator (99% OBW)
1.4	0.436	1M08G7D	0.341	1M08W7D
3	0.428	2M69G7D	0.377	2M68W7D
5	0.435	4M47G7D	0.348	4M47W7D
10	0.429	8M92G7D	0.386	8M94W7D
15	0.434	13M5G7D	0.378	13M5W7D
20	0.421	18M0G7D	0.355	18M0W7D

1.7. Modification of EUT

No modifications are made to the EUT during all test items.

NOTE: This document is issued by Shenzhen Morlab Communications Technology Co., Ltd., the test report shall not be reproduced except in full without prior written permission of the company. The test results apply only to the particular sample(s) tested and to the specific tests carried out which is available on request for validation and information confirmed at our website.



1.8. Laboratory Information

Laboratory Name	Shenzhen Morlab Communications Technology Co., Ltd.
Laboratory Address	FL.3, Building A, FeiYang Science Park, No.8 LongChang Road, Block 67, BaoAn District, ShenZhen, GuangDong Province, P. R. China
Telephone	+86 755 36698555
Facsimile	+86 755 36698525
FCC Designation Number	CN1192
FCC Test Firm Registration Number	226174

1.9. Applicable Standards

According to the specifications of the manufacturer, the EUT must comply with the requirements of the following standards:

47 CFR Part 2, 22(H), 24(E), 27(C)

ANSI C63.26-2015

FCC KDB 971168 D01 Power Meas License Digital Systems v03r01

FCC KDB 412172 D01 Determining ERP and EIRP v01r01

Remark:

All test items were verified and recorded according to the standards and without any deviation during the test.

1.10. Environmental conditions

Temperature	Normal Temperature(NT):	25°C
	High Temperature(HT):	45°C
	Low Temperature(LT):	0°C
Voltage	Normal Voltage(NV):	5V
	High Voltage(HV):	5.5V
	Low Voltage(LV):	4.5V
Other	Relative Humidity	55 %
	Air Pressure	101 kPa

NOTE: This document is issued by Shenzhen Morlab Communications Technology Co., Ltd., the test report shall not be reproduced except in full without prior written permission of the company. The test results apply only to the particular sample(s) tested and to the specific tests carried out which is available on request for validation and information confirmed at our website.



2. TEST CONFIGURATION OF EQUIPMENT UNDER TEST

2.1. Test Mode

Antenna port conducted and radiated test items listed below are performed according to KDB 971168 D01 Power Meas License Digital Systems v03r01 with maximum output power.

Radiated measurements are performed by rotating the EUT in three different orthogonal test planes to find the maximum emission. (X-Plane).

Test Items	Band	Bandwidth (MHz)						Modulation			RB #			Test Channel		
		1.4	3	5	10	15	20	QPSK	16QAM		1	Half	Full	L	M	H
Max. Output Power	2	√	√	√	√	√	√	√	√		√		√	√	√	√
	4	√	√	√	√	√	√	√	√		√		√	√	√	√
	5	√	√	√	√			√	√		√		√	√	√	√
	7	√	√	√	√			√	√		√		√	√	√	√
	12			√	√			√	√		√		√	√	√	√
	17			√	√	√	√	√	√		√		√	√	√	√
	41	√	√	√	√	√	√	√	√		√		√	√	√	√
	66			√	√	√	√	√	√		√		√	√	√	√
Peak-to-Average Ratio	2	√	√	√	√	√	√	√	√				√	√	√	√
	4	√	√	√	√	√	√	√	√				√	√	√	√
	5	√	√	√	√			√	√				√	√	√	√
	7	√	√	√	√			√	√				√	√	√	√
	12			√	√			√	√				√	√	√	√
	17			√	√	√	√	√	√				√	√	√	√
	41	√	√	√	√	√	√	√	√				√	√	√	√
	66			√	√	√	√	√	√				√	√	√	√
26dB and 99% Bandwidth	2	√	√	√	√	√	√	√	√				√	√	√	√
	4	√	√	√	√	√	√	√	√				√	√	√	√
	5	√	√	√	√			√	√				√	√	√	√
	7	√	√	√	√			√	√				√	√	√	√
	12			√	√			√	√				√	√	√	√
	17			√	√	√	√	√	√				√	√	√	√
	41	√	√	√	√	√	√	√	√				√	√	√	√
	66			√	√	√	√	√	√				√	√	√	√
Conducted Band Edge	2	√	√	√	√	√	√	√	√		√		√	√		√
	4	√	√	√	√	√	√	√	√		√		√	√		√
	5	√	√	√	√			√	√		√		√	√		√
	7	√	√	√	√			√	√		√		√	√		√
	12			√	√			√	√		√		√	√		√
	17			√	√	√	√	√	√		√		√	√		√
	41	√	√	√	√	√	√	√	√		√		√	√		√
	66			√	√	√	√	√	√		√		√	√		√
Conducted Spurious Emission	2	√	√	√	√	√	√	√	√		√		√	√	√	√
	4	√	√	√	√	√	√	√	√		√		√	√	√	√
	5	√	√	√	√			√	√		√		√	√	√	√
	7	√	√	√	√			√	√		√		√	√	√	√
	12			√	√			√	√		√		√	√	√	√
	17			√	√	√	√	√	√		√		√	√	√	√
	41	√	√	√	√	√	√	√	√		√		√	√	√	√
	66			√	√	√	√	√	√		√		√	√	√	√
Frequency Stability	2	√	√	√	√	√	√	√	√				√	√	√	√
	4	√	√	√	√	√	√	√	√				√	√	√	√
	5	√	√	√	√			√	√				√	√	√	√
	7	√	√	√	√			√	√				√	√	√	√
	12			√	√			√	√				√	√	√	√
	17			√	√	√	√	√	√				√	√	√	√
	41	√	√	√	√	√	√	√	√				√	√	√	√
	66			√	√	√	√	√	√				√	√	√	√
E.R.P/ E.I.R.P	2	√	√	√	√	√	√	√	√		√		√	√	√	√
	4	√	√	√	√	√	√	√	√		√		√	√	√	√
	5	√	√	√	√			√	√		√		√	√	√	√
	7	√	√	√	√			√	√		√		√	√	√	√
	12			√	√			√	√		√		√	√	√	√
	17			√	√	√	√	√	√		√		√	√	√	√
	41	√	√	√	√	√	√	√	√		√		√	√	√	√
	66			√	√	√	√	√	√		√		√	√	√	√

NOTE: This document is issued by Shenzhen Morlab Communications Technology Co., Ltd., the test report shall not be reproduced except in full without prior written permission of the company. The test results apply only to the particular sample(s) tested and to the specific tests carried out which is available on request for validation and information confirmed at our website.





	66			√	√	√	√	√	√			√		√	√	√	
Radiated Spurious Emission	2	Worst Case													√	√	√
	4	Worst Case													√	√	√
	5	Worst Case													√	√	√
	7	Worst Case													√	√	√
	12	Worst Case													√	√	√
	17	Worst Case													√	√	√
	41	Worst Case													√	√	√
	66	Worst Case													√	√	√
Note	1. The mark "√" ^m means that this configuration is chosen for testing. 2. When a cell is empty, it means it is not supported or does not require testing. 3. The device is investigated from 30MHz to 10 times of fundamental signal for radiated spurious emission test under different RB size/offset and modulations in exploratory test. Subsequently, only the worst case emissions are reported.																

NOTE: This document is issued by Shenzhen Morlab Communications Technology Co., Ltd., the test report shall not be reproduced except in full without prior written permission of the company. The test results apply only to the particular sample(s) tested and to the specific tests carried out which is available on request for validation and information confirmed at our website.



2.2. Connection Diagram of Test System

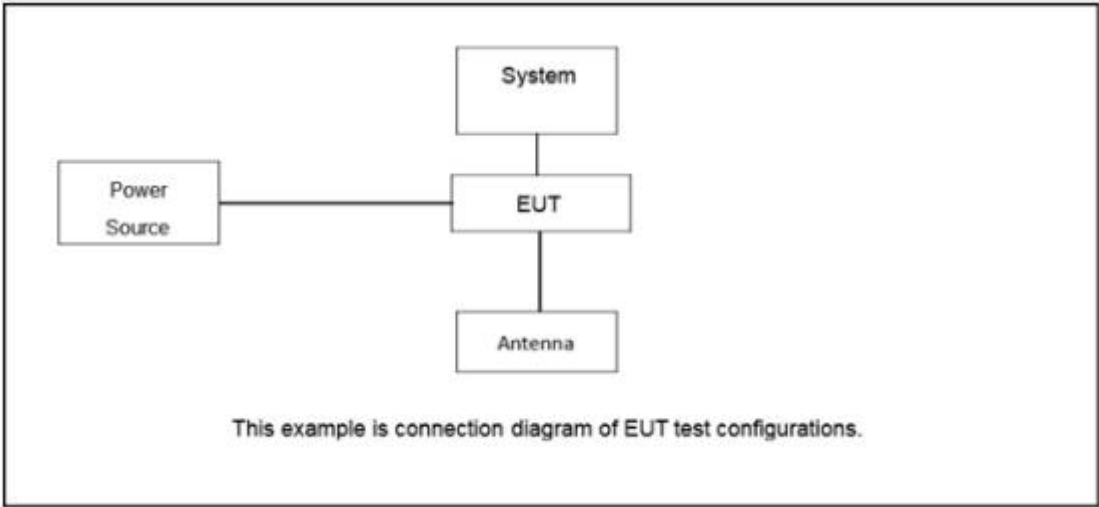

2.3. Support Unit used in test configuration and system

NO.	Unit	Brand	Model	Description
1	-	-	-	-
2	-	-	-	-
	-	-	-	-
	-	-	-	-
	-	-	-	-

NOTE: This document is issued by Shenzhen Morlab Communications Technology Co., Ltd., the test report shall not be reproduced except in full without prior written permission of the company. The test results apply only to the particular sample(s) tested and to the specific tests carried out which is available on request for validation and information confirmed at our website.



2.4. Frequency List of Low/Middle/High Channels

LTE Band 2 Channel and Frequency List				
BW [MHz]	Channel/Frequency(MHz)	Lowest	Middle	Highest
20	Channel	18700	18900	19100
	Frequency	1860	1880	1900
15	Channel	18675	18900	19125
	Frequency	1857.5	1880	1902.5
10	Channel	18650	18900	19150
	Frequency	1855	1880	1905
5	Channel	18625	18900	19175
	Frequency	1852.5	1880	1907.5
3	Channel	18615	18900	19185
	Frequency	1851.5	1880	1908.5
1.4	Channel	18607	18900	19193
	Frequency	1850.7	1880	1909.3

LTE Band 4 Channel and Frequency List				
BW [MHz]	Channel/Frequency(MHz)	Lowest	Middle	Highest
20	Channel	20050	20175	20300
	Frequency	1720	1732.5	1745
15	Channel	20025	20175	20325
	Frequency	1717.5	1732.5	1747.5
10	Channel	20000	20175	20350
	Frequency	1715	1732.5	1750
5	Channel	19975	20175	20375
	Frequency	1712.5	1732.5	1752.5
3	Channel	19965	20175	20385
	Frequency	1711.5	1732.5	1753.5
1.4	Channel	19957	20175	20393
	Frequency	1710.7	1732.5	1754.3

NOTE: This document is issued by Shenzhen Morlab Communications Technology Co., Ltd., the test report shall not be reproduced except in full without prior written permission of the company. The test results apply only to the particular sample(s) tested and to the specific tests carried out which is available on request for validation and information confirmed at our website.



LTE Band 5 Channel and Frequency List				
BW [MHz]	Channel/Frequency(MHz)	Lowest	Middle	Highest
10	Channel	20450	20525	20600
	Frequency	829	836.5	844
5	Channel	20425	20525	20625
	Frequency	826.5	836.5	846.5
3	Channel	20415	20525	20635
	Frequency	825.5	836.5	847.5
1.4	Channel	20407	20525	20643
	Frequency	824.7	836.5	848.3

LTE Band 7 Channel and Frequency List				
BW [MHz]	Channel/Frequency(MHz)	Lowest	Middle	Highest
20	Channel	20850	21100	21350
	Frequency	2510	2535	2560
15	Channel	21375	21100	20825
	Frequency	2562.5	2535	2507.5
10	Channel	20800	21100	21400
	Frequency	2505	2535	2565
5	Channel	20775	21100	21425
	Frequency	2502.5	2535	2567.5

LTE Band 12 Channel and Frequency List				
BW [MHz]	Channel/Frequency(MHz)	Lowest	Middle	Highest
10	Channel	23060	23095	23130
	Frequency	704	707.5	711
5	Channel	23035	23095	23155
	Frequency	701.5	707.5	713.5
3	Channel	23025	23095	23165
	Frequency	700.5	707.5	714.5
1.4	Channel	23017	23095	23173
	Frequency	699.7	707.5	715.3

LTE Band 17 Channel and Frequency List				
BW [MHz]	Channel/Frequency(MHz)	Lowest	Middle	Highest
10	Channel	23780	23790	23900
	Frequency	709	710	711
5	Channel	23755	23790	23825
	Frequency	706.5	710	713.5

NOTE: This document is issued by Shenzhen Morlab Communications Technology Co., Ltd., the test report shall not be reproduced except in full without prior written permission of the company. The test results apply only to the particular sample(s) tested and to the specific tests carried out which is available on request for validation and information confirmed at our website.



LTE Band 41 Channel and Frequency List				
BW [MHz]	Channel/Frequency(MHz)	Lowest	Middle	Highest
20	Channel	39750	40620	41490
	Frequency	2506	2593	2680
15	Channel	39725	40620	41515
	Frequency	2503.5	2593	2682.5
10	Channel	39700	40620	41540
	Frequency	2501	2593	2685
5	Channel	39675	40620	41565
	Frequency	2498.5	2593	2687.5

LTE Band 66 Channel and Frequency List				
BW [MHz]	Channel/Frequency(MHz)	Lowest	Middle	Highest
20	Channel	132072	132322	132572
	Frequency	1720	1745	1770
15	Channel	132047	132322	132597
	Frequency	1717.5	1745	1772.5
10	Channel	132022	132322	132622
	Frequency	1715	1745	1775
5	Channel	131997	132322	132647
	Frequency	1712.5	1745	1777.5
3	Channel	131987	132322	132657
	Frequency	1711.5	1745	1778.5
1.4	Channel	131979	132322	132665
	Frequency	1710.7	1745	1779.3

NOTE: This document is issued by Shenzhen Morlab Communications Technology Co., Ltd., the test report shall not be reproduced except in full without prior written permission of the company. The test results apply only to the particular sample(s) tested and to the specific tests carried out which is available on request for validation and information confirmed at our website.



2.5. Equipment List

2.5.1. For Conducted Test

Kind of Equipment	Manufacturer	Type No.	Serial No.	equipment number	Calibrated until	Calibrated due until	Cal. Interval
Environmental Test Chamber	BST	BST-HZ-410	T1131	SHMorlab-W041	2025.03.17	2026.03.16	1 year
Vector signal generator	Agilent	N5182A	MY50143555	SHMorlab-W037	2025.07.18	2026.07.17	1 year
Analog signal generator	Keysight	N5173B	MY60403026	SHMorlab-W038	2025.07.18	2026.07.17	1 year
Wideband radio communication tester	R&S	CMW500	101331	SHMorlab-W044	2025.07.28	2026.07.27	1 year
Spectrum analyzer	R&S	FSV40-N	101761	SHMorlab-W036	2025.07.28	2026.07.27	1 year
Switch Box	MaiWei	MW200-RFCB	MW220720Morlab	SHMorlab-W039	N/A	N/A	N/A
Thermometer	DeLi	N/A	N/A	SHMorlab-W012	2025.08.01	2026.07.31	1 year
Test Software	MaiWei	MW-Test	N/A	N/A	N/A	N/A	N/A
band rejection filter	MaiWei	MW200-SFCB	MW220719Morlab	SHMorlab-W040	2025.07.18	2026.07.17	1 year

NOTE: This document is issued by Shenzhen Morlab Communications Technology Co., Ltd., the test report shall not be reproduced except in full without prior written permission of the company. The test results apply only to the particular sample(s) tested and to the specific tests carried out which is available on request for validation and information confirmed at our website.



2.5.2. For Radiated Spurious Emission

Kind of Equipment	Manufacturer	Type No.	Serial No.	equipment number	Calibrated until	Calibrated due until	Cal. Interval
Signal analyzer	Agilent	N9020A	MY50200811	SHMorlab-E017	2025.03.17	2026.03.16	1 year
Amplifier	JPT	JPA0118-55-303A	1910001800055000	SHMorlab-E006	2025.03.24	2026.03.23	1 year
Amplifier	JPT	JPA-10M1G32	21010100035001	SHMorlab-E005	2025.03.17	2026.03.16	1 year
Antenna/Turn table Controller	Brilliant	N/A	N/A	SHMorlab-E007	N/A	N/A	N/A
Loop Antenna(9kHz-30MHz)	Daze	ZN30900C	20077	SHMorlab-E042	2025.05.13	2026.05.12	1 year
Bilog Antenna	SCHWARZBECK	VULB9168	01174	SHMorlab-E008	2025.05.20	2026.05.19	1 year
Broad-band Horn Antenna	SCHWARZBECK	BBHA9120D	02334	SHMorlab-E009	2025.05.20	2026.05.19	1 year
Horn Antenna	COM-POWERS	AH-1840	10100008	SHMorlab-E043	2025.07.27	2026.07.26	1 year
Thermometer	DeLi	N/A	N/A	SHMorlab-E015	2025.08.01	2026.07.31	1 year
Test Software	FALA	EMC-RI(Ver.4A2)	N/A	N/A	N/A	N/A	N/A
Wideband radio communication tester	R&S	CMW500	101331	SHMorlab-W044	2025.07.28	2026.07.27	1 year
Spectrum analyzer	R&S	FSV40-N	101761	SHMorlab-W036	2025.07.28	2026.07.27	1 year
Bilog Antenna (Substitute antenna)	SCHWARZBECK	VULB9168	12258719	SHMorlab-E045	2025.05.20	2026.05.19	1 year
Broad-band Horn Antenna (Substitute antenna)	SCHWARZBECK	BBHA9120D	587756	SHMorlab-E046	2025.05.20	2026.05.19	1 year

2.5.3. For AC Power-Line Conducted Emission

Kind of Equipment	Manufacturer	Type No.	Serial No.	equipment number	Calibrated until	Calibrated due until	Cal. Interval
EMI Test Receiver	R&S	ESPI	100679	SHMorlab-E012	2025.03.17	2026.03.16	1 year
LISN	R&S	ENV216	101300	SHMorlab-E013	2025.03.17	2026.03.16	1 year
LISN	R&S	ENV216	100333	SHMorlab-E041	2025.03.17	2026.03.16	1 year
CE Cable	Chuangce xing	2M	EMI0014	SHMorlab-E014	N/A	N/A	N/A
Temperature & Humidity	Deli	Deli	EMI0015	SHMorlab-E015	2025.08.01	2026.07.31	1 year
Testing Software	FALA	EZ-EMC(Ver.EMC-C ON 3A1.1)	EMI0044	SHMorlab-E044	N/A	N/A	N/A

NOTE: This document is issued by Shenzhen Morlab Communications Technology Co., Ltd., the test report shall not be reproduced except in full without prior written permission of the company. The test results apply only to the particular sample(s) tested and to the specific tests carried out which is available on request for validation and information confirmed at our website.



2.6. Measurement Uncertainty

The reported uncertainty of measurement $y \pm U$, where expanded uncertainty U is based on a standard uncertainty multiplied by a coverage factor of $k=2$, providing a level of confidence of approximately 95 %.

No.	Item	Uncertainty
1	Occupied Channel Bandwidth	$\pm 4\%$
2	Transmitter power conducted	± 0.56 dB
3	Transmitter power Radiated	± 2.20 dB
4	Conducted spurious emission	± 1.60 dB
5	Radiated spurious emission	± 2.20 dB
6	Temperature	± 0.6 °C
7	Humidity	$\pm 2\%$
8	DC and low frequency voltages	$\pm 0.05\%$
9	Radio frequency error	$\pm 3 \times 10^{-8}$

NOTE: This document is issued by Shenzhen Morlab Communications Technology Co., Ltd., the test report shall not be reproduced except in full without prior written permission of the company. The test results apply only to the particular sample(s) tested and to the specific tests carried out which is available on request for validation and information confirmed at our website.



3. TEST RESULT

3.1. Conducted Output Power and ERP/EIRP

3.1.1. Test Setup

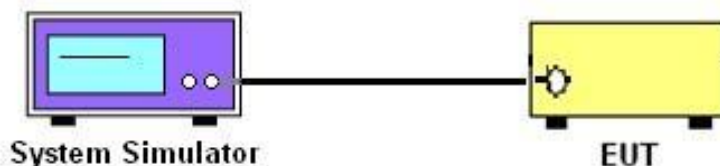

3.1.2. Description of the Conducted Output Power Measurement and ERP/EIRP

Measurement

A system simulator was used to establish communication with the EUT. Its parameters were set to force the EUT transmitting at maximum output power. The measured power in the radio frequency on the transmitter output terminals shall be reported.

The ERP of mobile transmitters must not exceed 7 Watts for LTE Band 5 .

The ERP of mobile transmitters must not exceed 3 Watts for LTE Band 12 Band 17.

The EIRP of mobile transmitters must not exceed 2 Watts for LTE Band 2 and Band 7, ,Band41.

The EIRP of mobile transmitters must not exceed 1 Watts for LTE Band 4 and Band 66.

According to KDB 412172 D01 Power Approach, $EIRP = P_T + G_T - L_C$, $ERP = EIRP - 2.15$, where P_T = transmitter output power in dBm, G_T = gain of the transmitting antenna in dBi, L_C = signal attenuation in the connecting cable between the transmitter and antenna in dB.

3.1.3. Test Procedures

1. The testing follows ANSI C63.26 Section 5.2.
2. The transmitter output port was connected to the system simulator.
3. Set EUT at maximum power through the system simulator.
4. Select lowest, middle, and highest channels for each band and different modulation.
5. Measure and record the power level from the system simulator.

3.1.4. Test Result of Conducted Output Power and ERP/EIRP

Please refer to the Appendix C1.

NOTE: This document is issued by Shenzhen Morlab Communications Technology Co., Ltd., the test report shall not be reproduced except in full without prior written permission of the company. The test results apply only to the particular sample(s) tested and to the specific tests carried out which is available on request for validation and information confirmed at our website.



3.2. Peak-to-Average Ratio

3.2.1. Test Setup

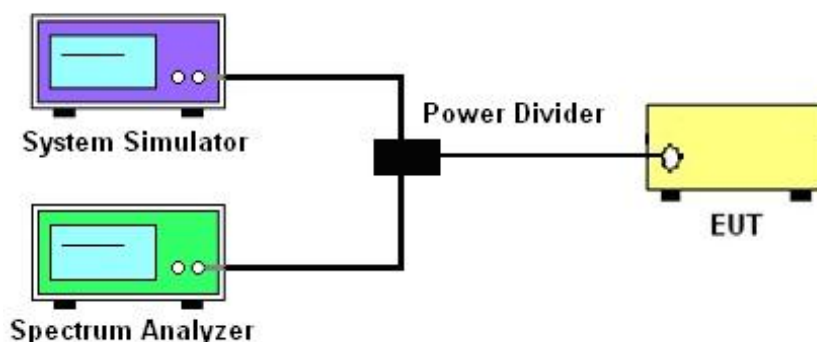

3.2.2. Description of the PAR Measurement

Power Complementary Cumulative Distribution Function (CCDF) curves provide a means for characterizing the power peaks of a digitally modulated signal on a statistical basis. A CCDF curve depicts the probability of the peak signal amplitude exceeding the average power level. Most contemporary measurement instrumentation include the capability to produce CCDF curves for an input signal provided that the instrument's resolution bandwidth can be set wide enough to accommodate the entire input signal bandwidth. In measuring transmissions in this band using an average power technique, the peak-to-average ratio (PAR) of the transmission may not exceed 13 dB.

3.2.3. Test Procedures

1. The testing follows ANSI C63.26 Section 5.2.3.4 (CCDF).
2. The EUT was connected to spectrum and system simulator via a power divider.
3. Set the CCDF (Complementary Cumulative Distribution Function) option in spectrum analyzer.
4. The highest RF powers were measured and recorded the maximum PAPR level associated with a probability of 0.1 %.
5. Record the deviation as Peak to Average Ratio.

3.2.4. Test Result of Peak-to-Average Ratio

Please refer to the Appendix C2.

NOTE: This document is issued by Shenzhen Morlab Communications Technology Co., Ltd., the test report shall not be reproduced except in full without prior written permission of the company. The test results apply only to the particular sample(s) tested and to the specific tests carried out which is available on request for validation and information confirmed at our website.



3.3. Occupied Bandwidth

3.3.1. Test Setup

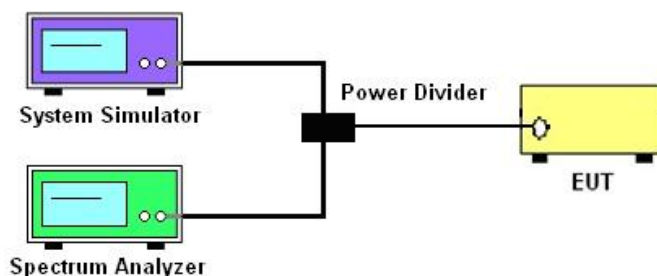

3.3.2. Description of Occupied Bandwidth Measurement

The occupied bandwidth is the width of a frequency band such that, below the lower and above the upper frequency limits, the mean powers emitted are each equal to a specified percentage 0.5% of the total mean transmitted power.

The 26 dB emission bandwidth is defined as the frequency range between two points, one above and one below the carrier frequency, at which the spectral density of the emission is attenuated 26 dB below the maximum in-band spectral density of the modulated signal. Spectral density (power per unit bandwidth) is to be measured with a detector of resolution bandwidth equal to approximately 1.0% of the emission bandwidth.

3.3.3. Test Procedures

1. The testing follows ANSI C63.26 Section 5.4.
2. The EUT was connected to spectrum analyzer and system simulator via a power divider.
3. The spectrum analyzer center frequency is set to the nominal EUT channel center frequency. The span range for the spectrum analyzer shall be between two and five times the anticipated OBW.
4. The nominal resolution bandwidth (RBW) shall be in the range of 1 to 5 % of the anticipated OBW, and the VBW shall be at least 3 times the RBW.
5. Set the detection mode to peak, and the trace mode to max hold.
6. Determine the reference value: Set the EUT to transmit a modulated signal. Allow the trace to stabilize. Set the spectrum analyzer marker to the highest level of the displayed trace.(this is the reference value)
7. Determine the “-26 dB down amplitude” as equal to (Reference Value – X).
8. Place two markers, one at the lowest and the other at the highest frequency of the envelope of the spectral display such that each marker is at or slightly below the “-X dB down amplitude” determined in step 6. If a marker is below this “-X dB down amplitude” value it shall be placed as close as possible to this value. The OBW is the positive frequency difference between the two markers.

NOTE: This document is issued by Shenzhen Morlab Communications Technology Co., Ltd., the test report shall not be reproduced except in full without prior written permission of the company. The test results apply only to the particular sample(s) tested and to the specific tests carried out which is available on request for validation and information confirmed at our website.





9. Use the 99 % power bandwidth function of the spectrum analyzer and report the measured bandwidth.

NOTE: This document is issued by Shenzhen Morlab Communications Technology Co., Ltd., the test report shall not be reproduced except in full without prior written permission of the company. The test results apply only to the particular sample(s) tested and to the specific tests carried out which is available on request for validation and information confirmed at our website.



3.3.4. Test Result of Occupied Bandwidth

Please refer to the Appendix C3.

3.4. Conducted Band Edge

3.4.1. Test Setup

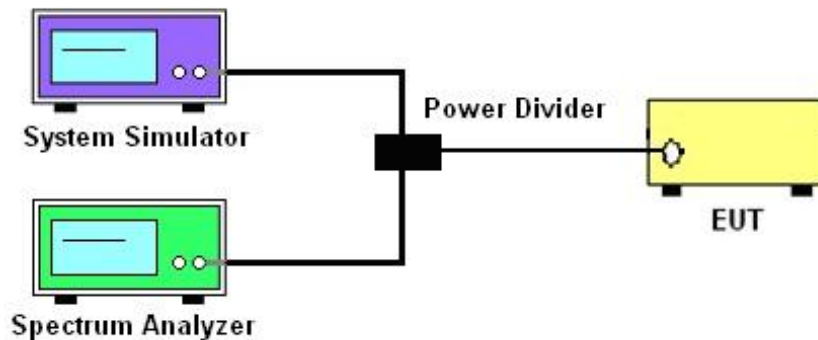

3.4.2. Description of Conducted Band Edge Measurement

22.917(a):

For operations in the 824 – 849 MHz band, the FCC limit is $43 + 10\log_{10}(P[\text{Watts}])$ dB below the transmitter power $P(\text{Watts})$ in a 100kHz bandwidth. However, in the 1MHz bands immediately outside and adjacent to the licensee's frequency block, a resolution bandwidth of at least one percent of the emission bandwidth of the fundamental emission of the transmitter may be employed.

24.238 (a):

For operations in the 1850-1910 and 1930-1990 MHz band, the FCC limit is $43 + 10\log_{10}(P[\text{Watts}])$ dB below the transmitter power $P(\text{Watts})$ in a 1MHz bandwidth. However, in the 1 MHz bands immediately outside and adjacent to the frequency block a resolution bandwidth of at least one percent of the emission bandwidth of the fundamental emission of the transmitter may be employed.

27.53 (g):

For operations in the 600MHz band and 698 -746 MHz band, the FCC limit is $43 + 10\log_{10}(P[\text{Watts}])$ dB below the transmitter power $P(\text{Watts})$ in a 100 kHz bandwidth. However, in the 100 kilohertz bands immediately outside and adjacent to a licensee's frequency block, a resolution bandwidth of at least 30 kHz may be employed.

27.53 (h):

For operations in the 1710 – 1755 MHz and 1710 – 1780 MHz band, the FCC limit is $43 + 10\log_{10}(P[\text{Watts}])$ dB below the transmitter power $P(\text{Watts})$ in a 1 MHz bandwidth. However, in the 1MHz bands immediately outside and adjacent to the licensee's frequency block, a resolution bandwidth of at least one percent of the emission bandwidth of the fundamental

NOTE: This document is issued by Shenzhen Morlab Communications Technology Co., Ltd., the test report shall not be reproduced except in full without prior written permission of the company. The test results apply only to the particular sample(s) tested and to the specific tests carried out which is available on request for validation and information confirmed at our website.





emission of the transmitter may be employed.

NOTE: This document is issued by Shenzhen Morlab Communications Technology Co., Ltd., the test report shall not be reproduced except in full without prior written permission of the company. The test results apply only to the particular sample(s) tested and to the specific tests carried out which is available on request for validation and information confirmed at our website.



3.4.3. Test Procedures

1. The testing follows ANSI C63.26 section 5.7
2. The EUT was connected to spectrum analyzer and system simulator via a power divider.
3. The band edges of low and high channels for the highest RF powers were measured.
4. Set RBW \geq 1% EBW in the 1MHz band immediately outside and adjacent to the band edge.
5. Beyond the 1 MHz band from the band edge, RBW=1MHz was used or a narrower RBW was used and the measured power was integrated over the full required measurement bandwidth of 1 MHz.
6. Set spectrum analyzer with RMS detector.
7. The RF fundamental frequency should be excluded against the limit line in the operating frequency band.
8. Checked that all the results comply with the emission limit line.

Example:

$$\begin{aligned} & \text{The limit line is derived from } 43 + 10\log(P)\text{dB below the transmitter power } P(\text{Watts}) \\ & = P(\text{W}) - [43 + 10\log(P)] \text{ (dB)} \\ & = [30 + 10\log(P)] \text{ (dBm)} - [43 + 10\log(P)] \text{ (dB)} = -13\text{dBm} \end{aligned}$$

9. When using the integration method, the starting frequency of the integration shall be centered at one-half of the RBW away from the band edge.

3.4.4. Test Result of Conducted Band Edge

Please refer to the Appendix C4.

NOTE: This document is issued by Shenzhen Morlab Communications Technology Co., Ltd., the test report shall not be reproduced except in full without prior written permission of the company. The test results apply only to the particular sample(s) tested and to the specific tests carried out which is available on request for validation and information confirmed at our website.



3.5. Conducted Spurious Emission

3.5.1. Test Setup

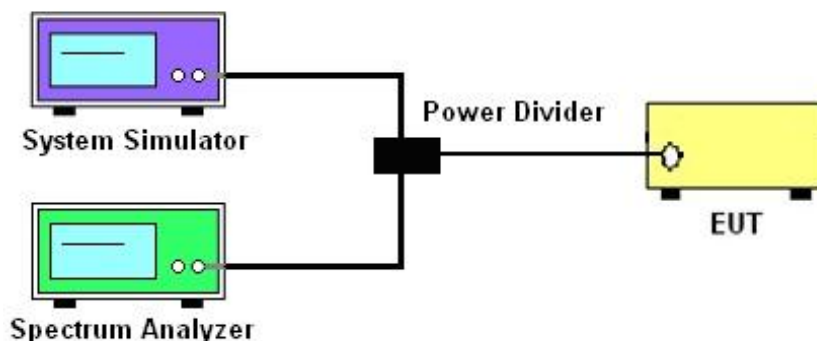

3.5.2. Description of Conducted Spurious Emission Measurement

The power of any emission outside of the authorized operating frequency ranges must be lower than the transmitter power (P) by a factor of at least $43 + 10 \log (P)$ dB.

It is measured by means of a calibrated spectrum analyzer and scanned from 30 MHz up to a frequency including its 10th harmonic.

3.5.3. Test Procedures

1. The testing follows ANSI C63.26 section 5.7
2. The EUT was connected to spectrum analyzer and system simulator via a power divider.
3. The RF output of EUT was connected to the spectrum analyzer by RF cable and attenuator. The path loss was compensated to the results for each measurement.
4. The middle channel for the highest RF power within the transmitting frequency was measured.
5. The conducted spurious emission for the whole frequency range was taken.
6. Make the measurement with the spectrum analyzer's RBW = 1MHz, VBW = 3MHz.
7. Set spectrum analyzer with RMS detector.
8. Taking the record of maximum spurious emission.
9. The RF fundamental frequency should be excluded against the limit line in the operating frequency band
10. The limit line is derived from $43 + 10\log(P)$ dB below the transmitter power P(Watts)
 $= P(W) - [43 + 10\log(P)]$ (dB) = $[30 + 10\log(P)]$ (dBm) - $[43 + 10\log(P)]$ (dB) = -13dBm.

3.5.4. Test Result of Conducted Spurious Emission

Please refer to the Appendix C5.

NOTE: This document is issued by Shenzhen Morlab Communications Technology Co., Ltd., the test report shall not be reproduced except in full without prior written permission of the company. The test results apply only to the particular sample(s) tested and to the specific tests carried out which is available on request for validation and information confirmed at our website.



3.6. Frequency Stability

3.6.1. Test Setup

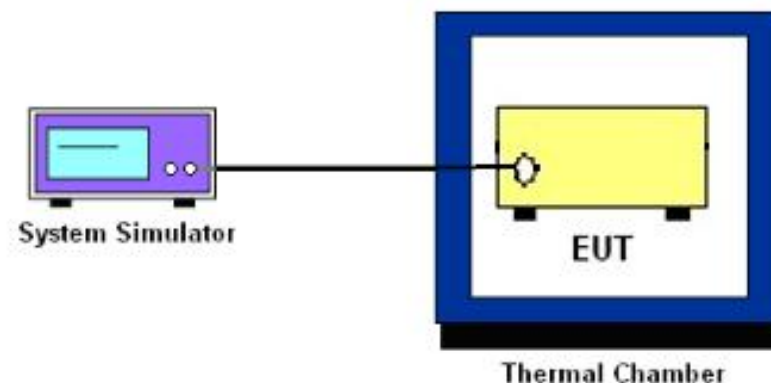

3.6.2. Description of Frequency Stability Measurement

The frequency stability shall be measured by variation of ambient temperature and variation of primary supply voltage to ensure that the fundamental emission stays within the authorized frequency block. The frequency stability of the transmitter shall be maintained within $\pm 0.00025\%$ ($\pm 2.5\text{ppm}$) of the center frequency.

3.6.3. Test Procedures for Temperature Variation

1. The testing follows ANSI C63.26 section 5.6.4.
2. The EUT was set up in the thermal chamber and connected with the system simulator.
3. With power OFF, the temperature was decreased to -30°C and the EUT was stabilized before testing. Power was applied and the maximum change in frequency was recorded within one minute.
4. With power OFF, the temperature was raised in 10°C step up to 50°C . The EUT was stabilized at each step for at least half an hour. Power was applied and the maximum frequency change was recorded within one minute.

3.6.4. Test Procedures for Voltage Variation

1. The testing follows ANSI C63.26 section 5.6.5
2. The EUT was placed in a temperature chamber at $20\pm 5^{\circ}\text{C}$ and connected with the system simulator.
3. The power supply voltage to the EUT was varied from 85% to 115% of the nominal value

NOTE: This document is issued by Shenzhen Morlab Communications Technology Co., Ltd., the test report shall not be reproduced except in full without prior written permission of the company. The test results apply only to the particular sample(s) tested and to the specific tests carried out which is available on request for validation and information confirmed at our website.



for other than hand carried battery equipment.

4. For hand carried, battery powered equipment, reduce the primary ac or dc supply voltage to the battery operating end point, which shall be specified by the manufacturer.

5. The variation in frequency was measured for the worst case.

3.6.5. Test Result of Frequency Stability

Please refer to the Appendix C6.

NOTE: This document is issued by Shenzhen Morlab Communications Technology Co., Ltd., the test report shall not be reproduced except in full without prior written permission of the company. The test results apply only to the particular sample(s) tested and to the specific tests carried out which is available on request for validation and information confirmed at our website.



3.7. Radiated Spurious Emission

3.7.1. Test Setup

3.7.1.1. For radiated test below 30MHz

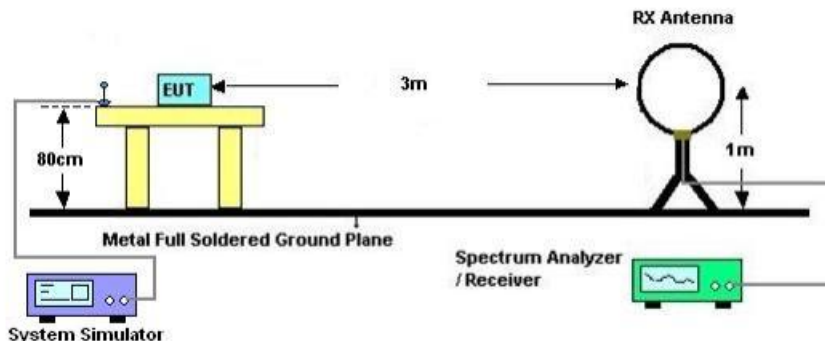

3.7.1.2. For radiated test from 30MHz to 1GHz

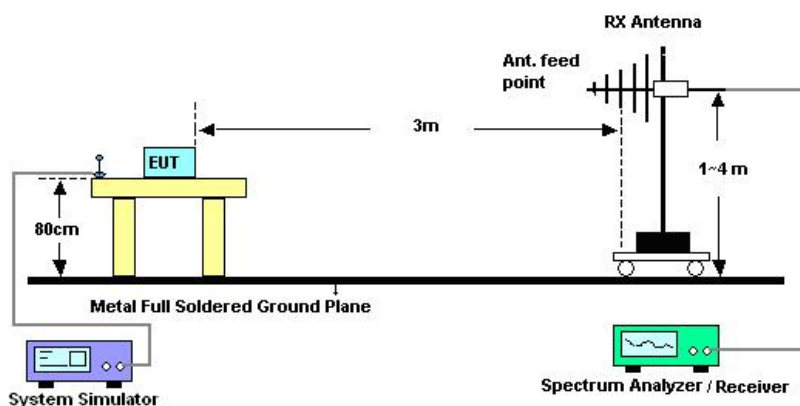

3.7.1.3. For radiated test above 1GHz

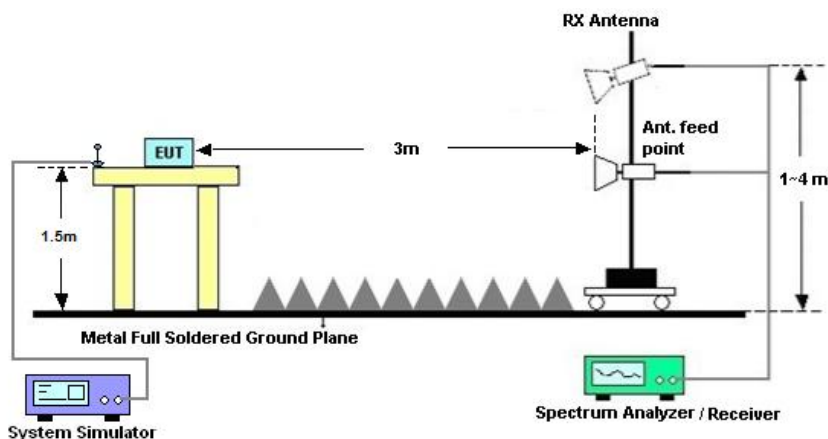

NOTE: This document is issued by Shenzhen Morlab Communications Technology Co., Ltd., the test report shall not be reproduced except in full without prior written permission of the company. The test results apply only to the particular sample(s) tested and to the specific tests carried out which is available on request for validation and information confirmed at our website.



3.7.2. Description of Radiated Spurious Emission

The radiated spurious emission was measured by substitution method according to ANSI C63.26.

The power of any emission outside of the authorized operating frequency ranges must be attenuated below the transmitter power (P) by a factor of at least $43 + 10 \log(P)$ dB.

The spectrum is scanned from 30 MHz up to a frequency including its 10th harmonic.

3.7.3. Test Procedures

1. The testing follows ANSI C63.26 Section 5.5
2. The EUT was placed on a turntable with 0.8 meter height for frequency below 1GHz and 1.5 meter height for frequency above 1GHz respectively above ground.
3. The EUT was set 3 meters from the receiving antenna mounted on the antenna tower.
4. The table was rotated 360 degrees to determine the position of the highest spurious emission.
5. The height of the receiving antenna is varied between 1m to 4m to search the maximum spurious emission for both horizontal and vertical polarizations.
6. During the measurement, the system simulator parameters were set to force the EUT transmitting at maximum output power.
7. Make the measurement with the spectrum analyzer's RBW = 1MHz, VBW = 3MHz, taking the record of maximum spurious emission.
8. A horn antenna was substituted in place of the EUT and was driven by a signal generator.
9. Tune the output power of signal generator to the same emission level with EUT maximum spurious emission.
10. $EIRP \text{ (dBm)} = S.G. \text{ Power} - Tx \text{ Cable Loss} + Tx \text{ Antenna Gain}$
11. $ERP \text{ (dBm)} = EIRP - 2.15$
12. The RF fundamental frequency should be excluded against the limit line in the operating frequency band.

The limit line is derived from $43 + 10\log(P)$ dB below the transmitter power P(Watts)
 $= P(W) - [43 + 10\log(P)] \text{ (dB)}$
 $= [30 + 10\log(P)] \text{ (dBm)} - [43 + 10\log(P)] \text{ (dB)}$
 $= -13\text{dBm}.$

3.7.4. Test Result of Radiated Spurious Emission

The low frequency, which started from 9 kHz to 30 MHz, was pre-scanned and the result which was 20dB lower than the limit line was not reported.

NOTE: This document is issued by Shenzhen Morlab Communications Technology Co., Ltd., the test report shall not be reproduced except in full without prior written permission of the company. The test results apply only to the particular sample(s) tested and to the specific tests carried out which is available on request for validation and information confirmed at our website.



Radiated spurious emissions - MS allocated a channel:

Below 1GHz:

Note:

All modes have been tested, only worst case(LTE Band 2_Traffic Mode_High CH)mode was recorded in the test report.

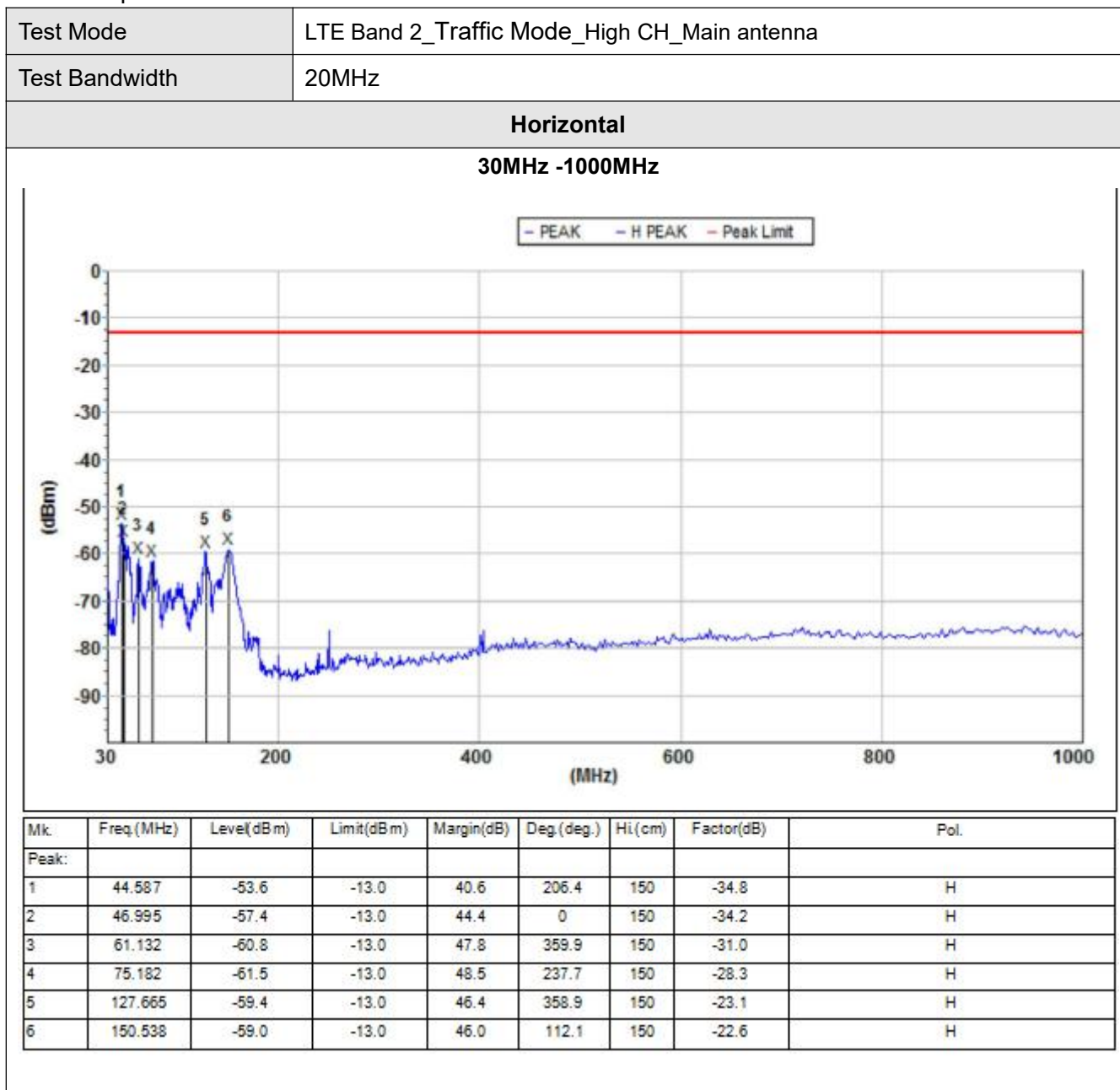

NOTE: This document is issued by Shenzhen Morlab Communications Technology Co., Ltd., the test report shall not be reproduced except in full without prior written permission of the company. The test results apply only to the particular sample(s) tested and to the specific tests carried out which is available on request for validation and information confirmed at our website.



Test Mode	LTE Band 2_Traffic Mode_High CH_Main antenna
Test Bandwidth	20MHz

Vertical

30MHz -1000MHz

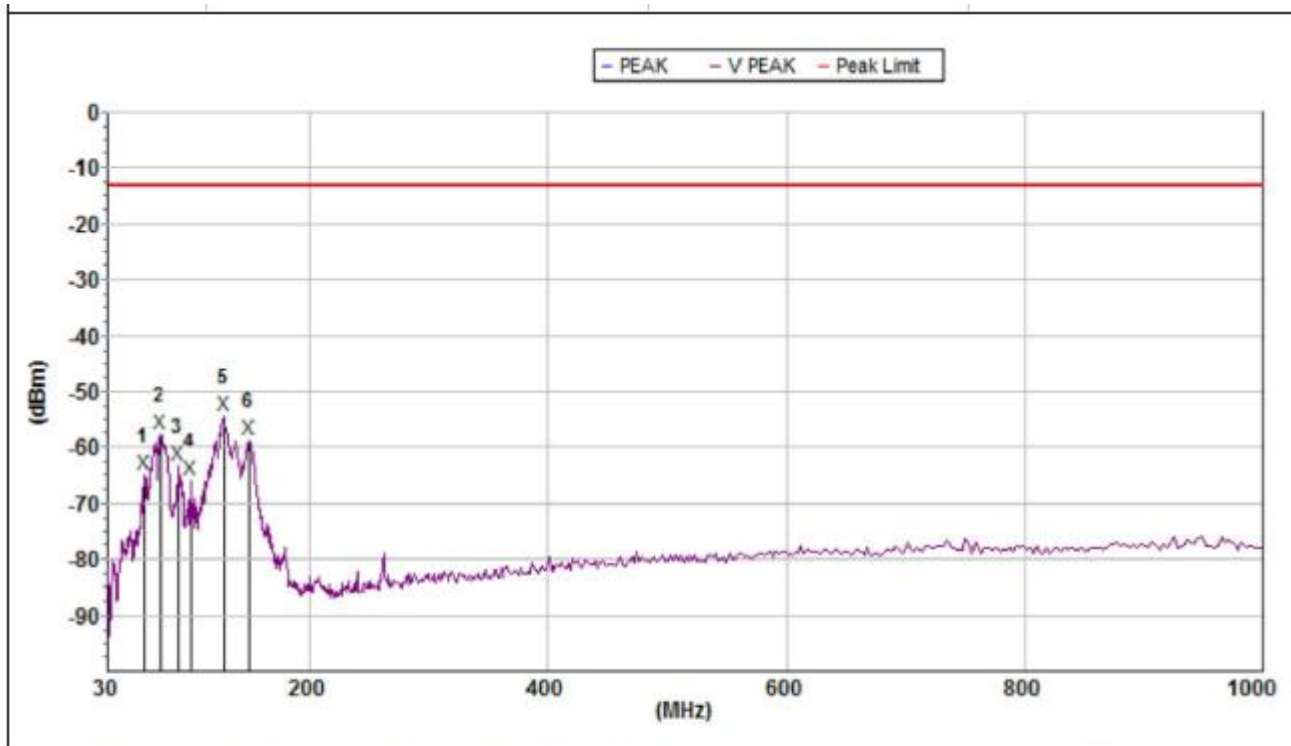

Mk	Freq (MHz)	Level(dBm)	Limit(dBm)	Margin(dB)	Deg.(deg.)	Hi(cm)	Factor(dB)	Pol.
Peak:								
1	61.562	-64.7	-13.0	51.7	111.77	150	-32.0	V
2	74.919	-57.6	-13.0	44.6	353.59	150	-28.0	V
3	89.905	-63.3	-13.0	50.3	174.32	150	-25.3	V
4	99.528	-65.7	-13.0	52.7	161.87	150	-23.6	V
5	127.665	-54.4	-13.0	41.4	199.57	150	-20.3	V
6	149.486	-58.7	-13.0	45.7	161.87	150	-21.4	V

NOTE: This document is issued by Shenzhen Morlab Communications Technology Co., Ltd., the test report shall not be reproduced except in full without prior written permission of the company. The test results apply only to the particular sample(s) tested and to the specific tests carried out which is available on request for validation and information confirmed at our website.



Above1GHz:

Test Mode	LTE Band 2_Traffic Mode_High CH_Main antenna
Test Bandwidth	20MHz

Horizontal

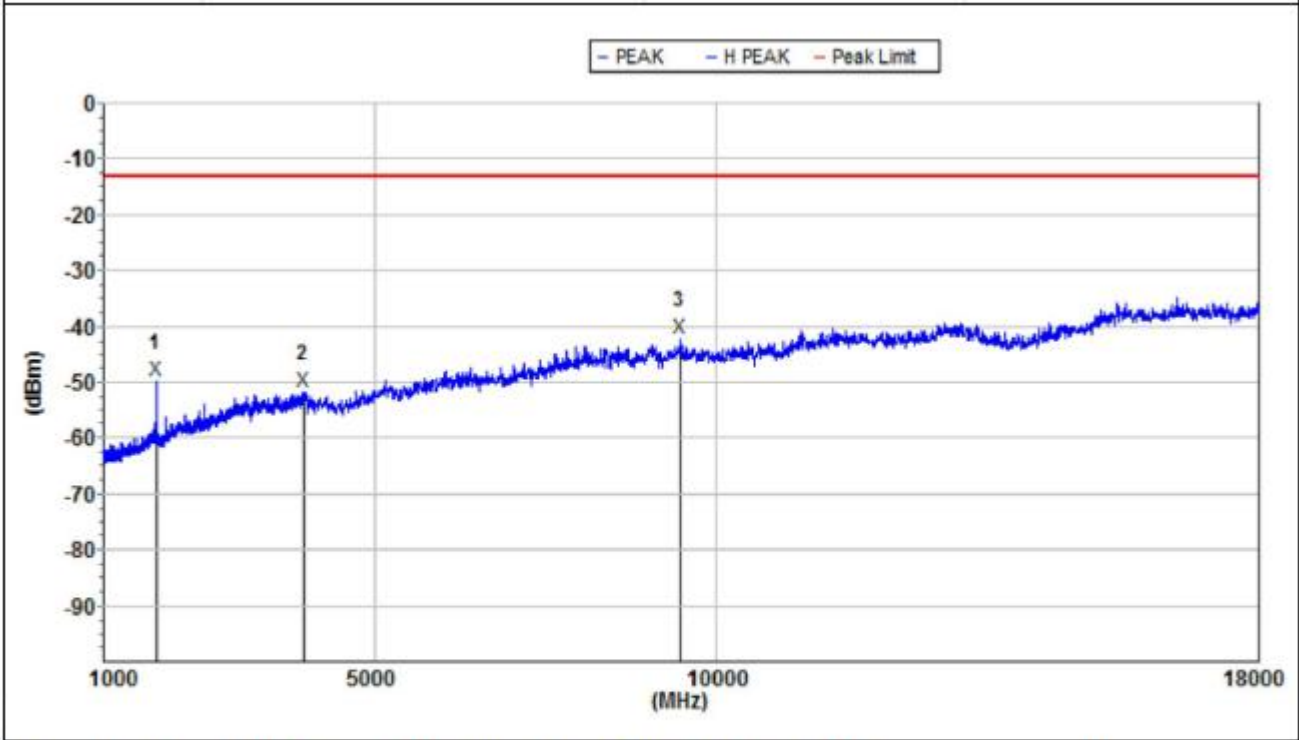

Mk	Freq.(MHz)	Level(dBm)	Limit(dBm)	Margin(dB)	Deg.(deg.)	Hl(cm)	Factor(dB)	Pol.
Peak:								
1	1784.500	-49.7	-13.0	36.7	0	150	-13.2	H
2	3955.000	-51.7	-13.0	38.7	359.6	150	-5.2	H
3	9481.000	-42.2	-13.0	29.2	359.6	150	5.4	H

NOTE: This document is issued by Shenzhen Morlab Communications Technology Co., Ltd., the test report shall not be reproduced except in full without prior written permission of the company. The test results apply only to the particular sample(s) tested and to the specific tests carried out which is available on request for validation and information confirmed at our website.



Test Mode	LTE Band 2_Traffic Mode_High CH_Main antenna
Test Bandwidth	20MHz

Vertical

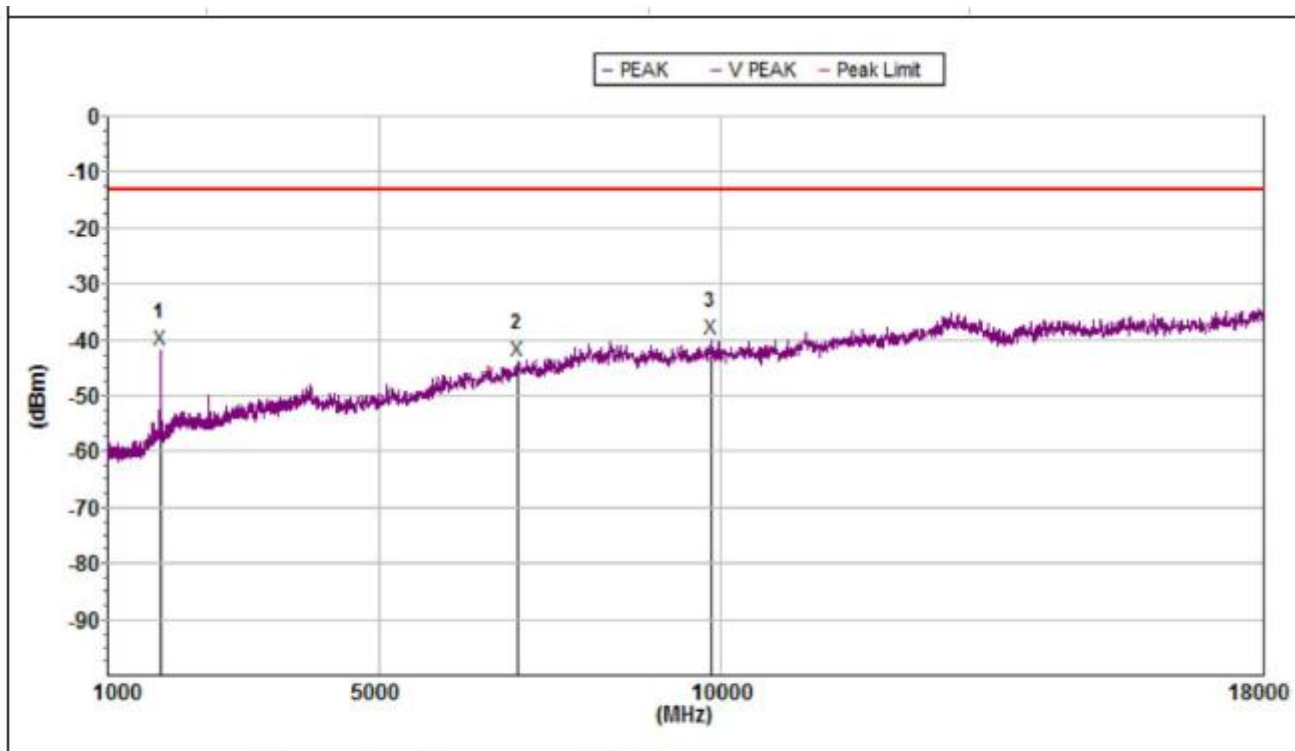

Mk.	Freq.(MHz)	Level(dBm)	Limit(dBm)	Margin(dB)	Deg.(deg.)	Hi.(cm)	Factor(dB)	Pol.
Peak:								
1	1784.500	-41.8	-13.0	28.8	133.3	150	-10.2	V
2	7045.000	-43.8	-13.0	30.8	359.9	150	4.6	V
3	9866.000	-39.9	-13.0	26.9	359.9	150	7.6	V

NOTE: This document is issued by Shenzhen Morlab Communications Technology Co., Ltd., the test report shall not be reproduced except in full without prior written permission of the company. The test results apply only to the particular sample(s) tested and to the specific tests carried out which is available on request for validation and information confirmed at our website.



Test Mode	LTE Band 2_Traffic Mode_Mid CH_Main antenna
Test Bandwidth	20MHz

Horizontal

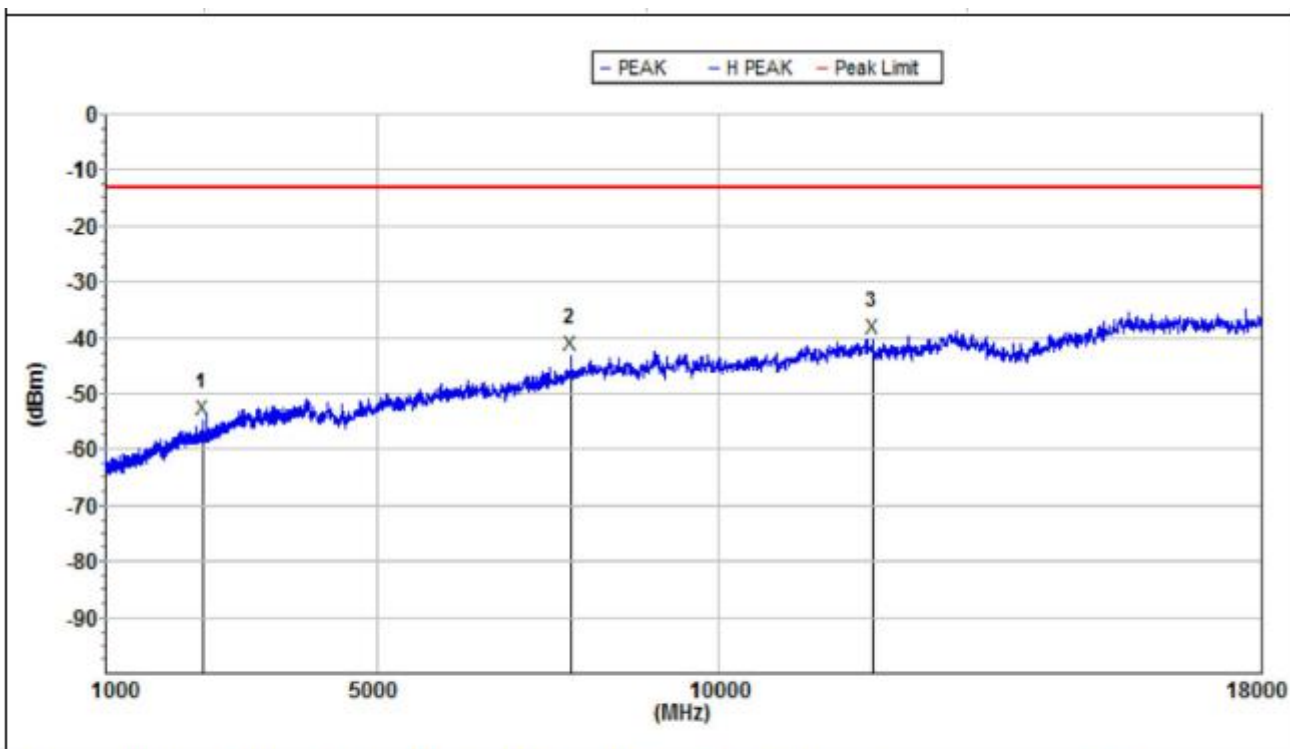

Mk	Freq.(MHz)	Level(dBm)	Limit(dBm)	Margin(dB)	Deg.(deg.)	Hi.(cm)	Factor(dB)	Pol.
Peak:								
1	2435.500	-54.5	-13.0	41.5	333.6	150	-11.7	H
2	7843.000	-43.1	-13.0	30.1	360	150	3.7	H
3	12281.000	-40.2	-13.0	27.2	360	150	8.0	H

NOTE: This document is issued by Shenzhen Morlab Communications Technology Co., Ltd., the test report shall not be reproduced except in full without prior written permission of the company. The test results apply only to the particular sample(s) tested and to the specific tests carried out which is available on request for validation and information confirmed at our website.



Test Mode	LTE Band 2_Traffic Mode_Mid CH_Main antenna
Test Bandwidth	20MHz

Vertical

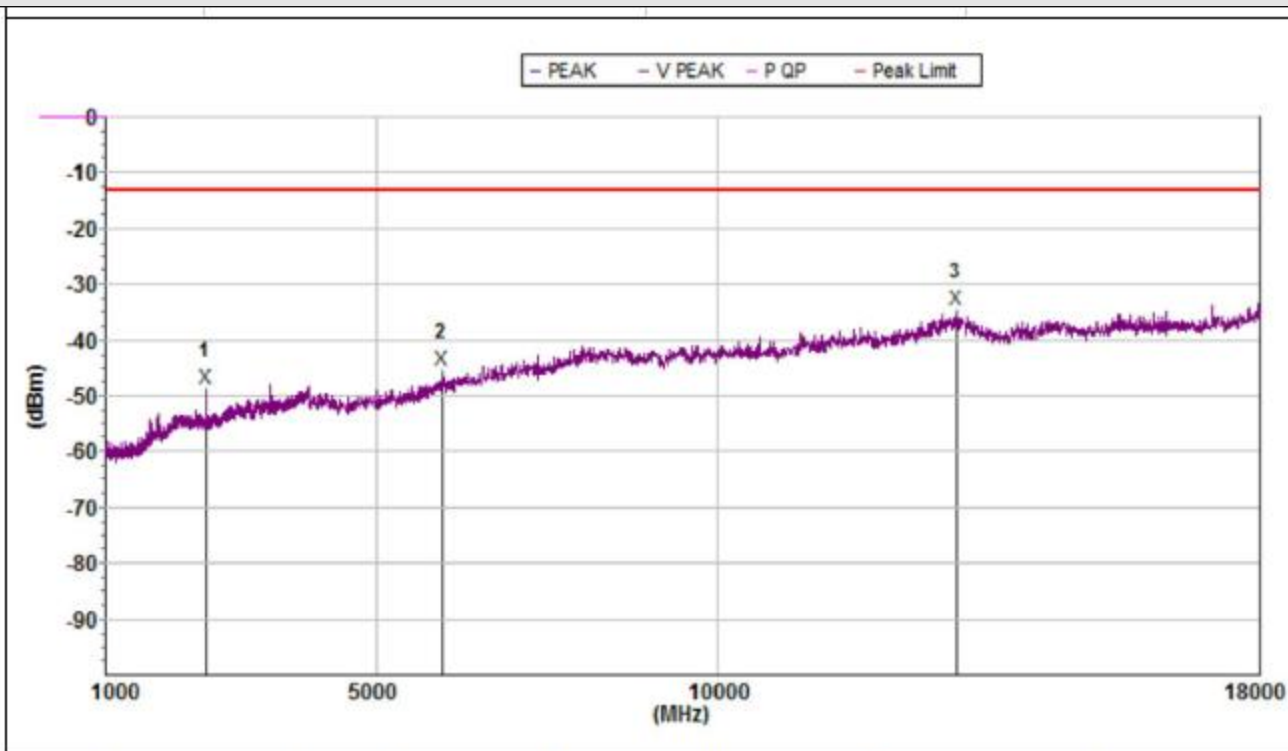

Mk.	Freq.(MHz)	Level(dBm)	Limit(dBm)	Margin(dB)	Deg.(deg.)	Hi(cm)	Factor(dB)	Pol.
Peak:								
1	2500.000	-48.8	-13.0	35.8	208	150	-9.1	V
2	5960.000	-45.5	-13.0	32.5	359.3	150	2.1	V
3	13541.000	-34.7	-13.0	21.7	359.3	150	13.3	V

NOTE: This document is issued by Shenzhen Morlab Communications Technology Co., Ltd., the test report shall not be reproduced except in full without prior written permission of the company. The test results apply only to the particular sample(s) tested and to the specific tests carried out which is available on request for validation and information confirmed at our website.



Test Mode	LTE Band 2_Traffic Mode_Low CH_Main antenna
Test Bandwidth	20MHz

Horizontal

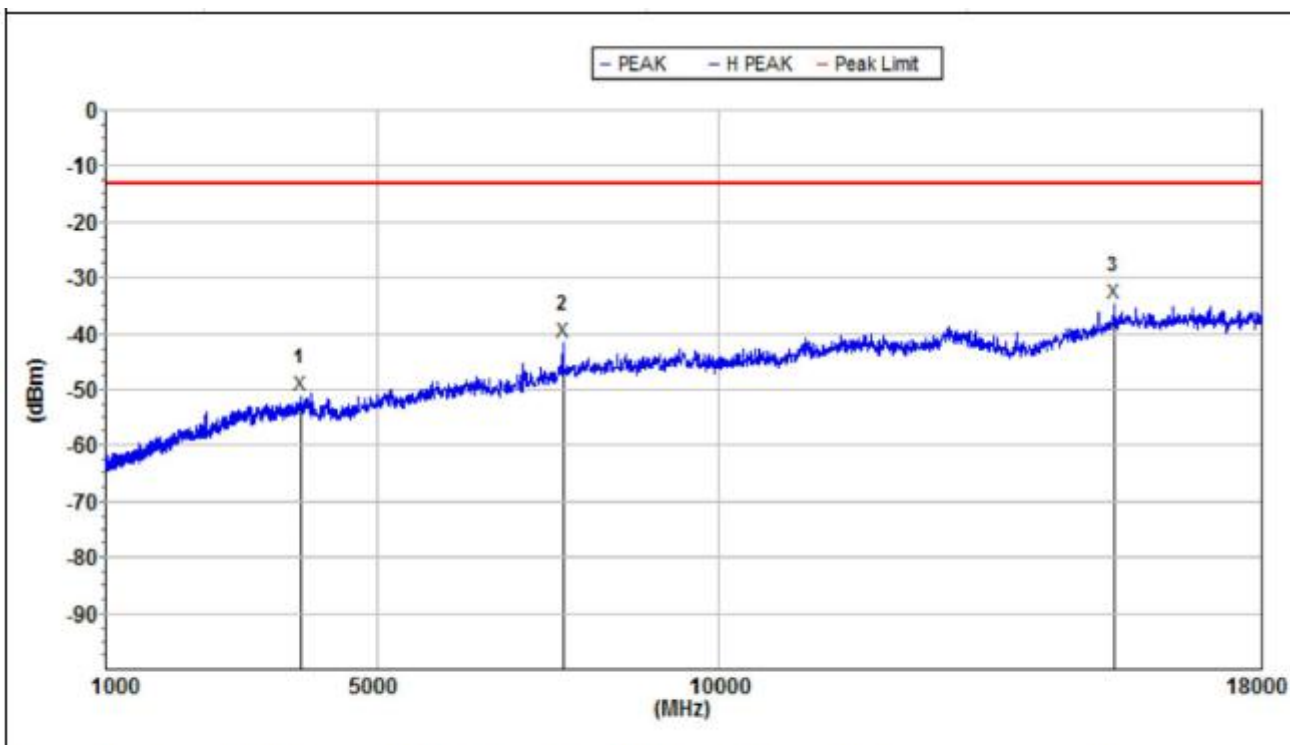

Mk.	Freq.(MHz)	Level(dBm)	Limit(dBm)	Margin(dB)	Deg.(deg.)	Hi.(cm)	Factor(dB)	Pol.
Peak:								
1	3871.000	-50.9	-13.0	37.9	359.3	150	-5.7	H
2	7731.000	-41.5	-13.0	28.5	0	150	3.4	H
3	15837.000	-34.5	-13.0	21.5	0	150	12.9	H

NOTE: This document is issued by Shenzhen Morlab Communications Technology Co., Ltd., the test report shall not be reproduced except in full without prior written permission of the company. The test results apply only to the particular sample(s) tested and to the specific tests carried out which is available on request for validation and information confirmed at our website.



Test Mode	LTE Band 2_Traffic Mode_Low CH_Main antenna
Test Bandwidth	20MHz

Vertical

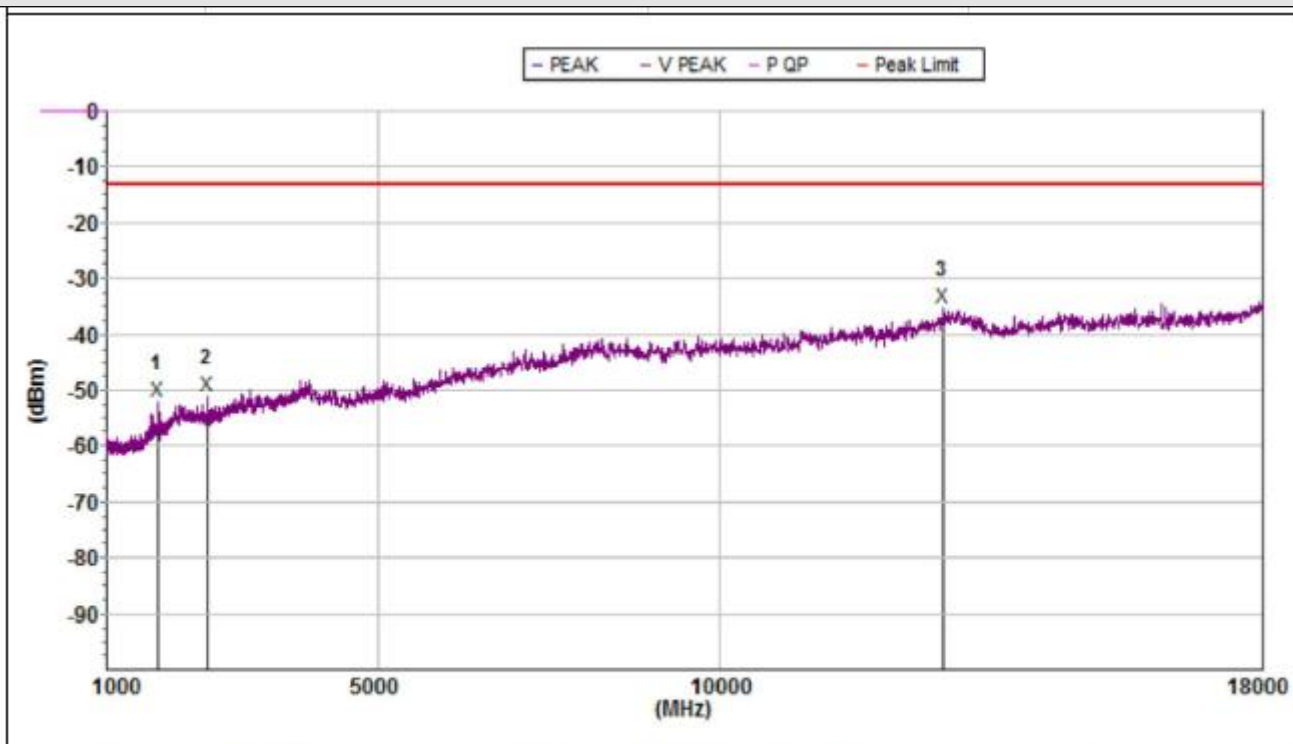

Mk.	Freq (MHz)	Level (dBm)	Limit (dBm)	Margin (dB)	Deg. (deg.)	Hi (cm)	Factor (dB)	Pol.
Peak:								
1	1750.000	-51.9	-13.0	38.9	184.3	150	-10.7	V
2	2500.000	-50.9	-13.0	37.9	231.2	150	-9.1	V
3	13303.000	-35.1	-13.0	22.1	359	150	12.6	V

NOTE: This document is issued by Shenzhen Morlab Communications Technology Co., Ltd., the test report shall not be reproduced except in full without prior written permission of the company. The test results apply only to the particular sample(s) tested and to the specific tests carried out which is available on request for validation and information confirmed at our website.



Test Mode	LTE Band 4_Traffic Mode_High CH_Main antenna
Test Bandwidth	20MHz

Horizontal

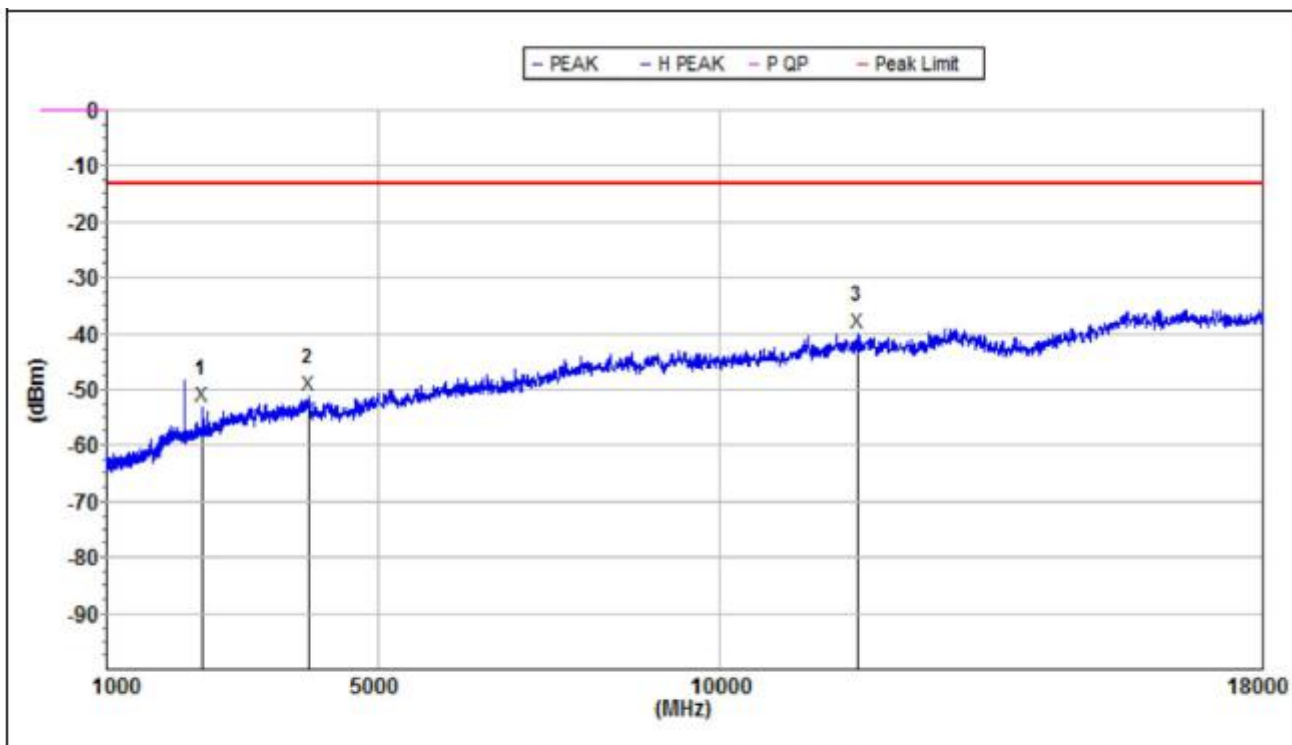

Mk.	Freq.(MHz)	Level(dBm)	Limit(dBm)	Margin(dB)	Deg.(deg.)	Hi.(cm)	Factor(dB)	Pol.
Peak:								
1	2420.500	-53.1	-13.0	40.1	149.2	150	-11.4	H
2	3979.000	-51.1	-13.0	38.1	18.8	150	-5.0	H
3	12036.000	-39.7	-13.0	26.7	0	150	8.1	H

NOTE: This document is issued by Shenzhen Morlab Communications Technology Co., Ltd., the test report shall not be reproduced except in full without prior written permission of the company. The test results apply only to the particular sample(s) tested and to the specific tests carried out which is available on request for validation and information confirmed at our website.



Test Mode	LTE Band 4_Traffic Mode_High CH_Main antenna
Test Bandwidth	20MHz

Vertical

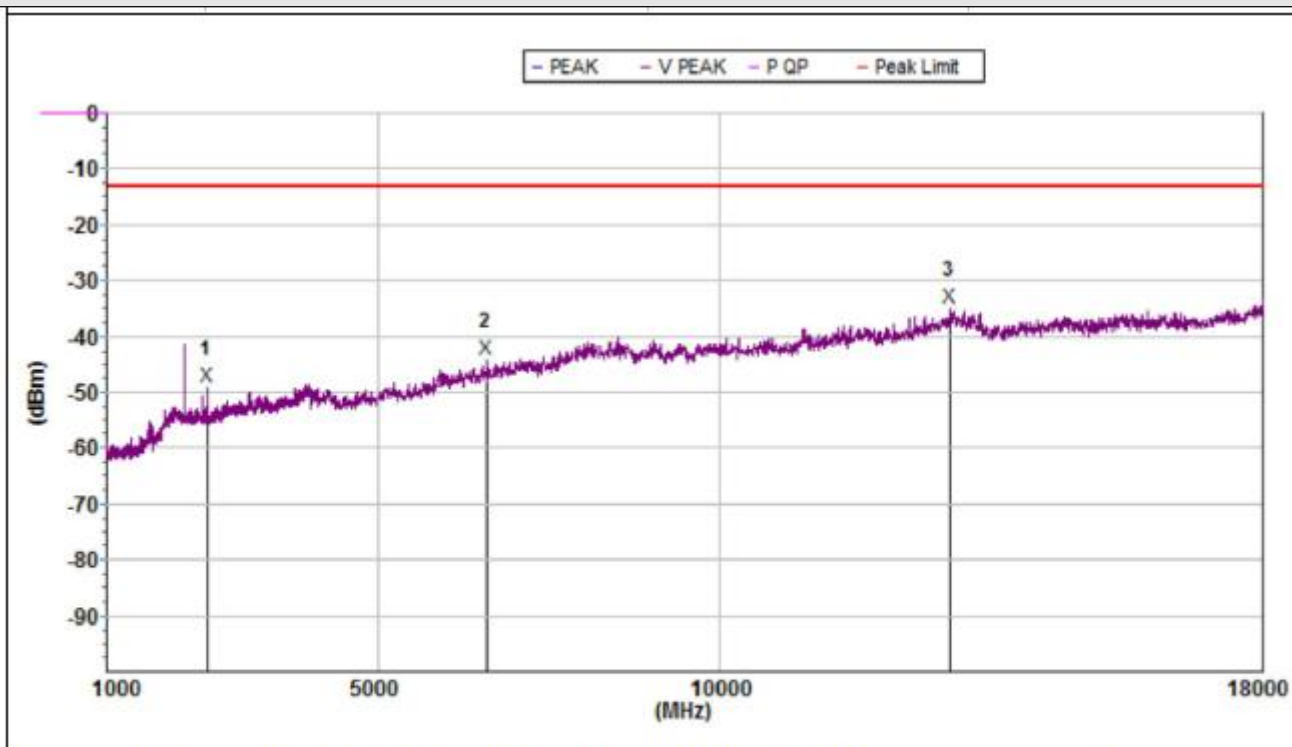

Mk.	Freq.(MHz)	Level(dBm)	Limit(dBm)	Margin(dB)	Deg.(deg.)	Hi(cm)	Factor(dB)	Pol.
Peak:								
1	2500.000	-49.0	-13.0	36.0	204.3	150	-9.0	V
2	6590.000	-44.2	-13.0	31.2	359.3	150	3.8	V
3	13415.000	-35.0	-13.0	22.0	359.3	150	13.1	V

NOTE: This document is issued by Shenzhen Morlab Communications Technology Co., Ltd., the test report shall not be reproduced except in full without prior written permission of the company. The test results apply only to the particular sample(s) tested and to the specific tests carried out which is available on request for validation and information confirmed at our website.



Test Mode	LTE Band 4_Traffic Mode_Mid CH_Main antenna
Test Bandwidth	20MHz

Horizontal

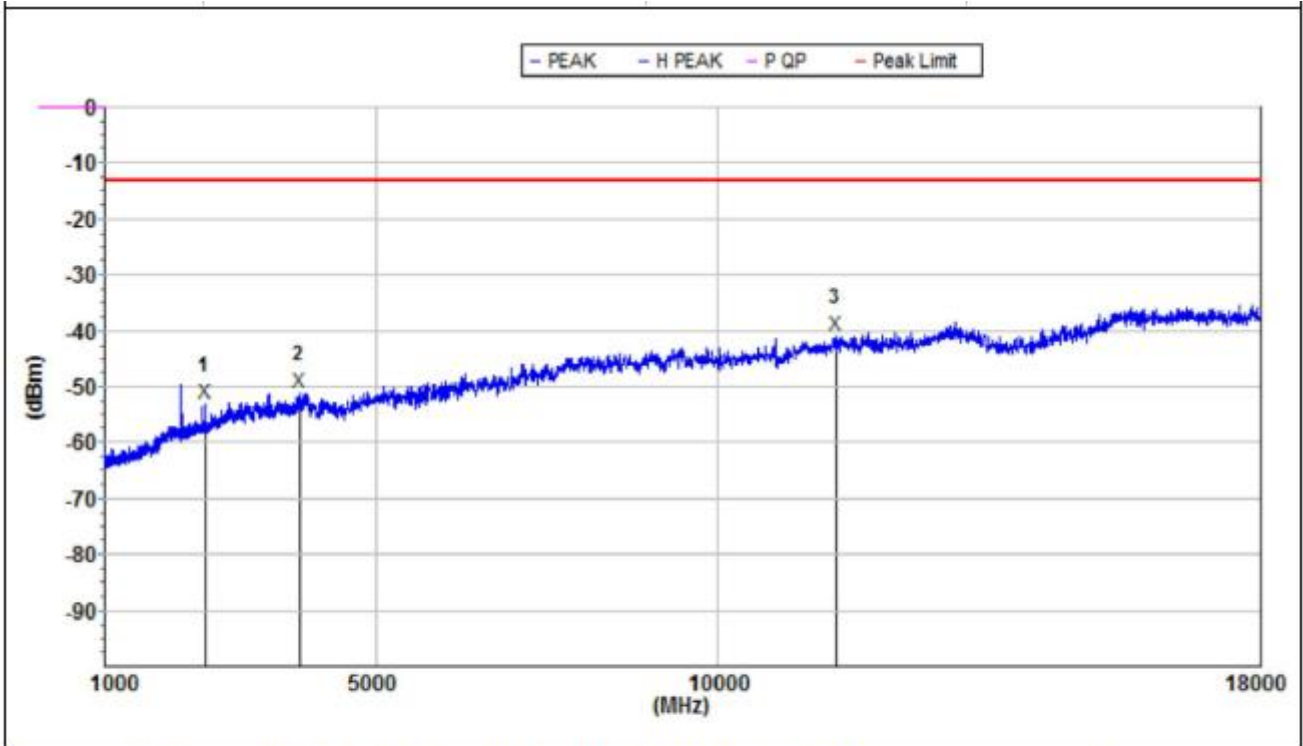

Mk.	Freq.(MHz)	Level(dBm)	Limit(dBm)	Margin(dB)	Deg.(deg.)	Hi.(cm)	Factor(dB)	Pol.
Peak:								
1	2500.000	-53.0	-13.0	40.0	51.4	150	-11.6	H
2	3877.000	-51.1	-13.0	38.1	0.4	150	-5.6	H
3	11749.000	-40.8	-13.0	27.8	0.4	150	7.6	H

NOTE: This document is issued by Shenzhen Morlab Communications Technology Co., Ltd., the test report shall not be reproduced except in full without prior written permission of the company. The test results apply only to the particular sample(s) tested and to the specific tests carried out which is available on request for validation and information confirmed at our website.



Test Mode	LTE Band 4_Traffic Mode_Mid CH_Main antenna
Test Bandwidth	20MHz

Vertical

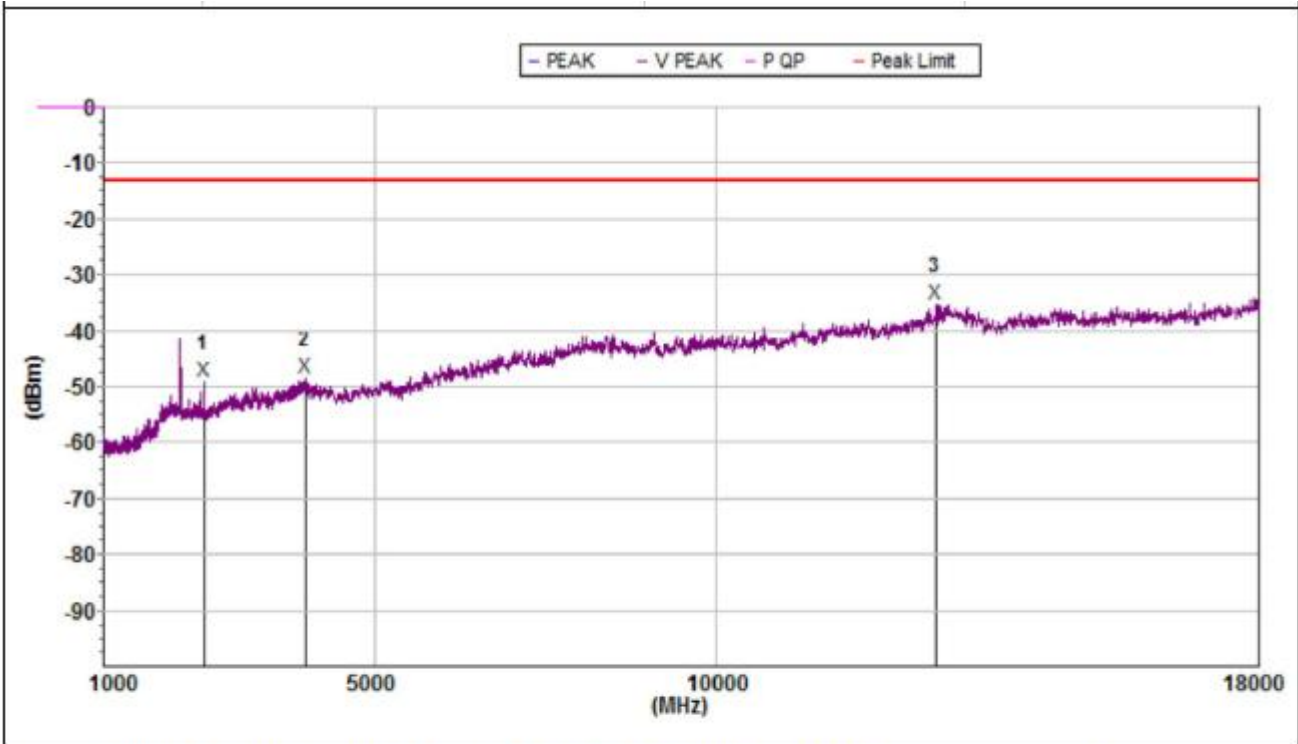

Mk.	Freq.(MHz)	Level(dBm)	Limit(dBm)	Margin(dB)	Deg.(deg.)	Hi.(cm)	Factor(dB)	Pol.
Peak:								
1	2500.000	-49.0	-13.0	36.0	243.1	150	-9.0	V
2	3964.000	-48.4	-13.0	35.4	0	150	-2.3	V
3	13254.000	-35.2	-13.0	22.2	359.8	150	12.5	V

NOTE: This document is issued by Shenzhen Morlab Communications Technology Co., Ltd., the test report shall not be reproduced except in full without prior written permission of the company. The test results apply only to the particular sample(s) tested and to the specific tests carried out which is available on request for validation and information confirmed at our website.



Test Mode	LTE Band 4_Traffic Mode_Low CH_Main antenna
Test Bandwidth	20MHz

Horizontal

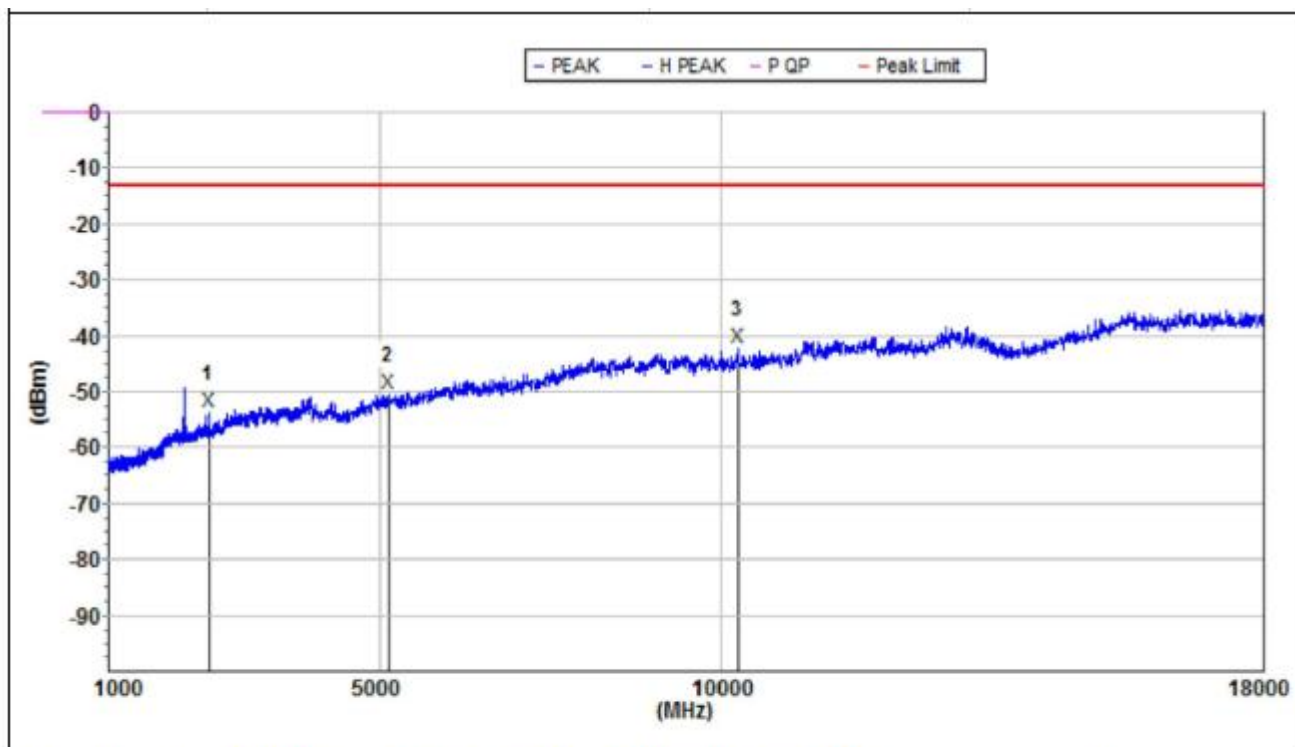

Mk.	Freq (MHz)	Level(dBm)	Limit(dBm)	Margin(dB)	Deg.(deg.)	Hi(cm)	Factor(dB)	Pol.
Peak:								
1	2500.000	-53.6	-13.0	40.6	49.2	150	-11.6	H
2	5120.000	-50.4	-13.0	37.4	0.1	150	-2.2	H
3	10258.000	-42.0	-13.0	29.0	0.1	150	5.2	H

NOTE: This document is issued by Shenzhen Morlab Communications Technology Co., Ltd., the test report shall not be reproduced except in full without prior written permission of the company. The test results apply only to the particular sample(s) tested and to the specific tests carried out which is available on request for validation and information confirmed at our website.



Test Mode	LTE Band 4_Traffic Mode_Low CH_Main antenna
Test Bandwidth	20MHz

Vertical

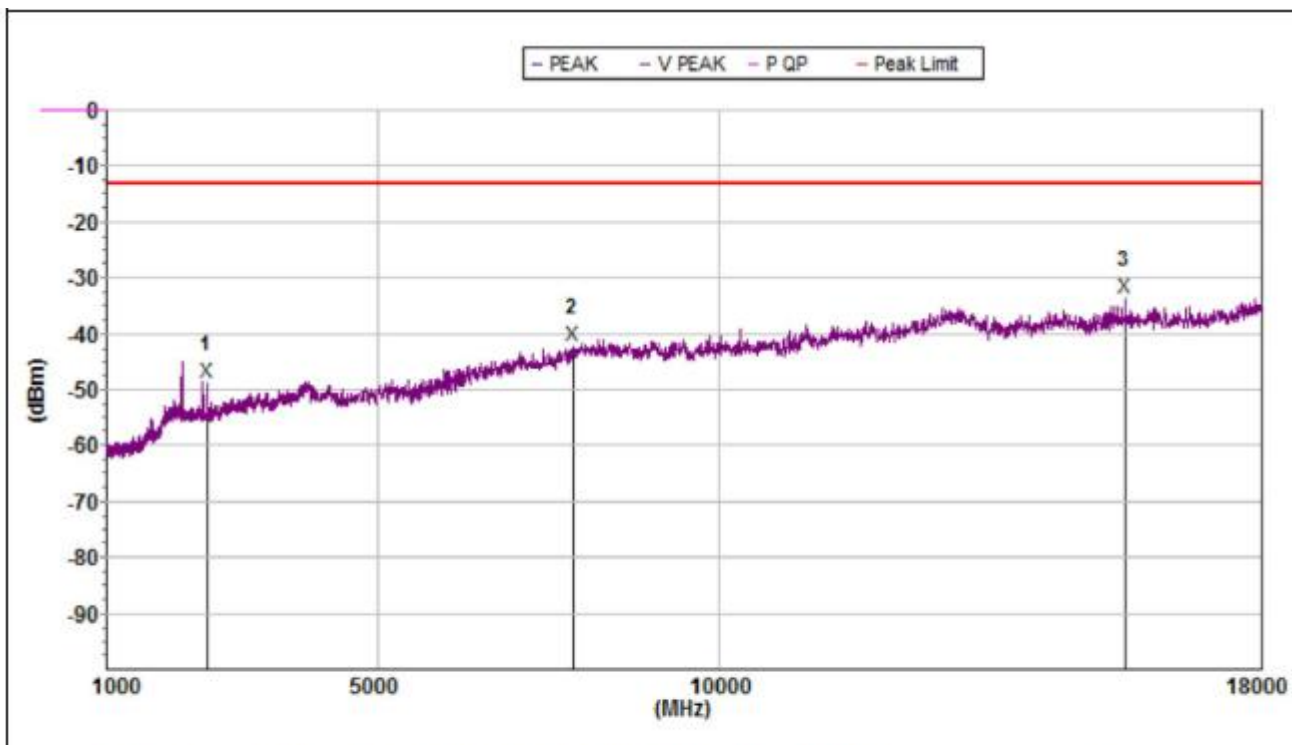

Mk.	Freq.(MHz)	Level(dBm)	Limit(dBm)	Margin(dB)	Deg.(deg.)	Hi.(cm)	Factor(dB)	Pol.
Peak:								
1	2500.000	-48.7	-13.0	35.7	232.6	150	-9.0	V
2	7864.000	-42.1	-13.0	29.1	359.6	150	6.8	V
3	15991.000	-33.6	-13.0	20.6	359.6	150	14.0	V

NOTE: This document is issued by Shenzhen Morlab Communications Technology Co., Ltd., the test report shall not be reproduced except in full without prior written permission of the company. The test results apply only to the particular sample(s) tested and to the specific tests carried out which is available on request for validation and information confirmed at our website.



Test Mode	LTE Band 5_Traffic Mode_High CH_Main antenna
Test Bandwidth	10MHz

Horizontal

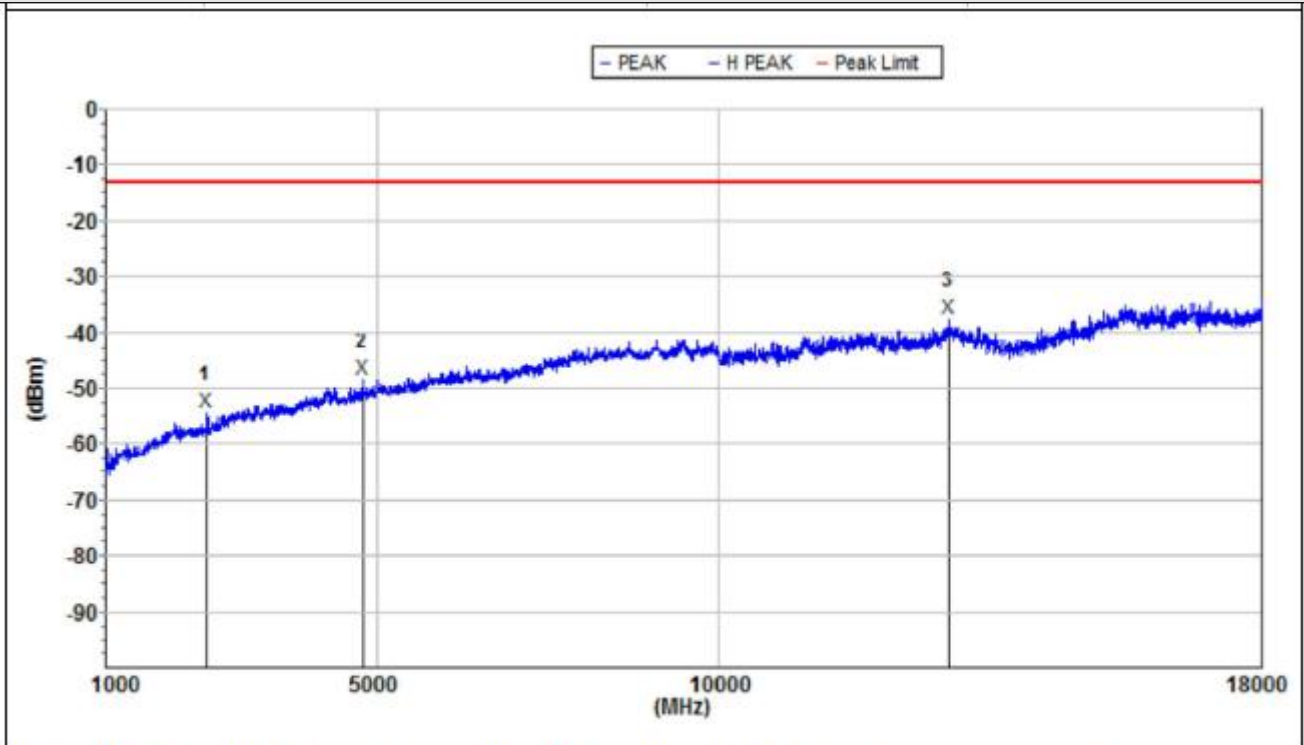

Mk	Freq.(MHz)	Level(dBm)	Limit(dBm)	Margin(dB)	Deg.(deg.)	Hi.(cm)	Factor(dB)	Pol.
Peak:								
1	2498.500	-54.4	-13.0	41.4	44.1	150	-11.8	H
2	4775.500	-48.3	-13.0	35.3	275.9	150	-3.3	H
3	13396.000	-37.6	-13.0	24.6	360	150	9.5	H

NOTE: This document is issued by Shenzhen Morlab Communications Technology Co., Ltd., the test report shall not be reproduced except in full without prior written permission of the company. The test results apply only to the particular sample(s) tested and to the specific tests carried out which is available on request for validation and information confirmed at our website.



Test Mode	LTE Band 5_Traffic Mode_High CH_Main antenna
Test Bandwidth	10MHz

Vertical

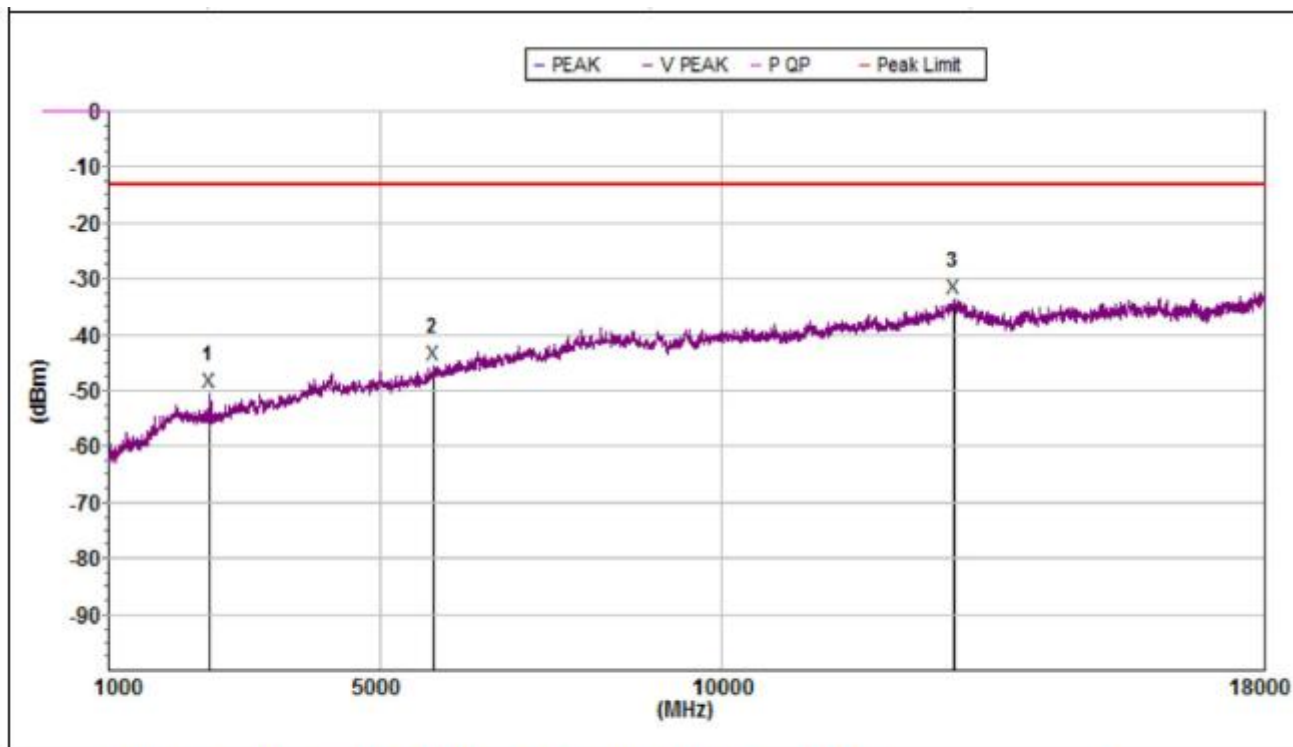

Mk.	Freq.(MHz)	Level(dBm)	Limit(dBm)	Margin(dB)	Deg.(deg.)	Hi(cm)	Factor(dB)	Pol.
Peak:								
1	2498.500	-50.4	-13.0	37.4	243.9	150	-9.2	V
2	5788.000	-45.4	-13.0	32.4	262.8	150	1.0	V
3	13428.000	-33.4	-13.0	20.4	156.7	150	13.2	V

NOTE: This document is issued by Shenzhen Morlab Communications Technology Co., Ltd., the test report shall not be reproduced except in full without prior written permission of the company. The test results apply only to the particular sample(s) tested and to the specific tests carried out which is available on request for validation and information confirmed at our website.



Test Mode	LTE Band 5_Traffic Mode_Mid CH_Main antenna
Test Bandwidth	10MHz

Horizontal

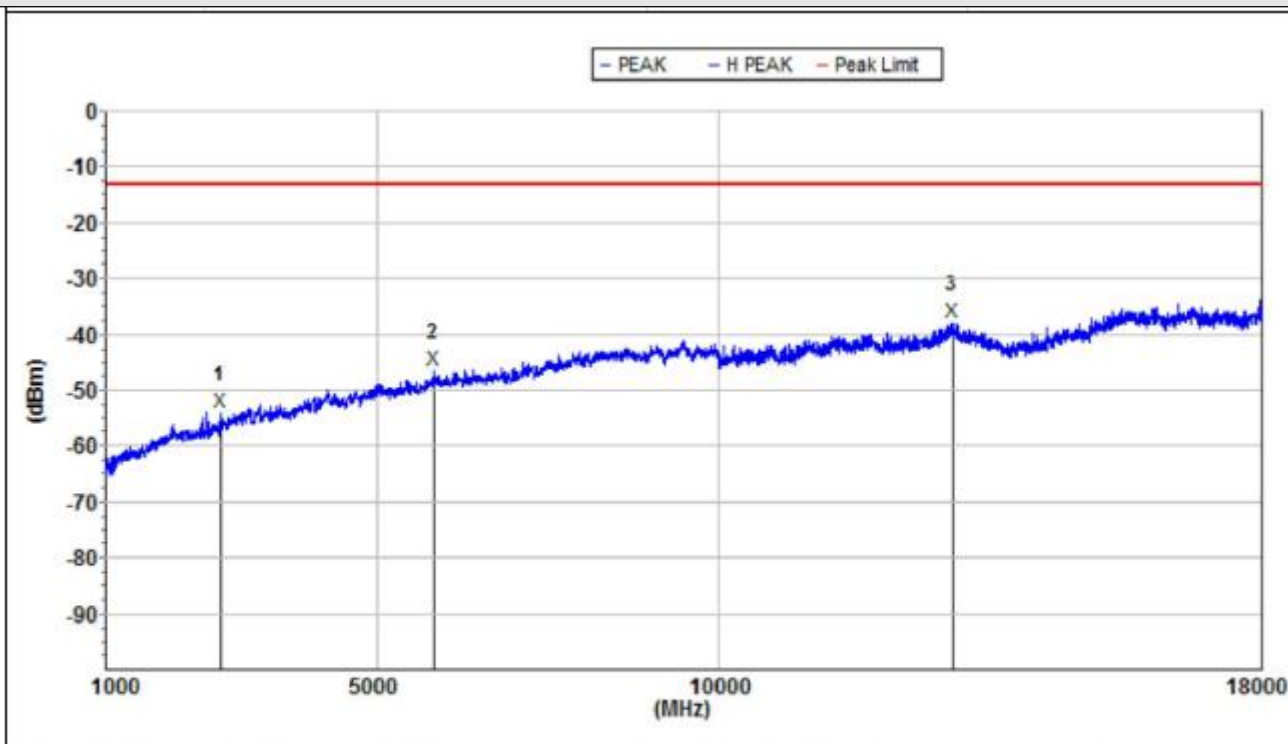

Mk	Freq.(MHz)	Level(dBm)	Limit(dBm)	Margin(dB)	Deg.(deg.)	Ht(cm)	Factor(dB)	Pol.
Peak:								
1	2710.000	-53.9	-13.0	40.9	306.2	150	-10.3	H
2	5819.500	-46.5	-13.0	33.5	249.4	150	-0.6	H
3	13444.000	-37.9	-13.0	24.9	0.3	150	9.7	H

NOTE: This document is issued by Shenzhen Morlab Communications Technology Co., Ltd., the test report shall not be reproduced except in full without prior written permission of the company. The test results apply only to the particular sample(s) tested and to the specific tests carried out which is available on request for validation and information confirmed at our website.



Test Mode	LTE Band 5_Traffic Mode_MinCH_Main antenna
Test Bandwidth	10MHz

Vertical

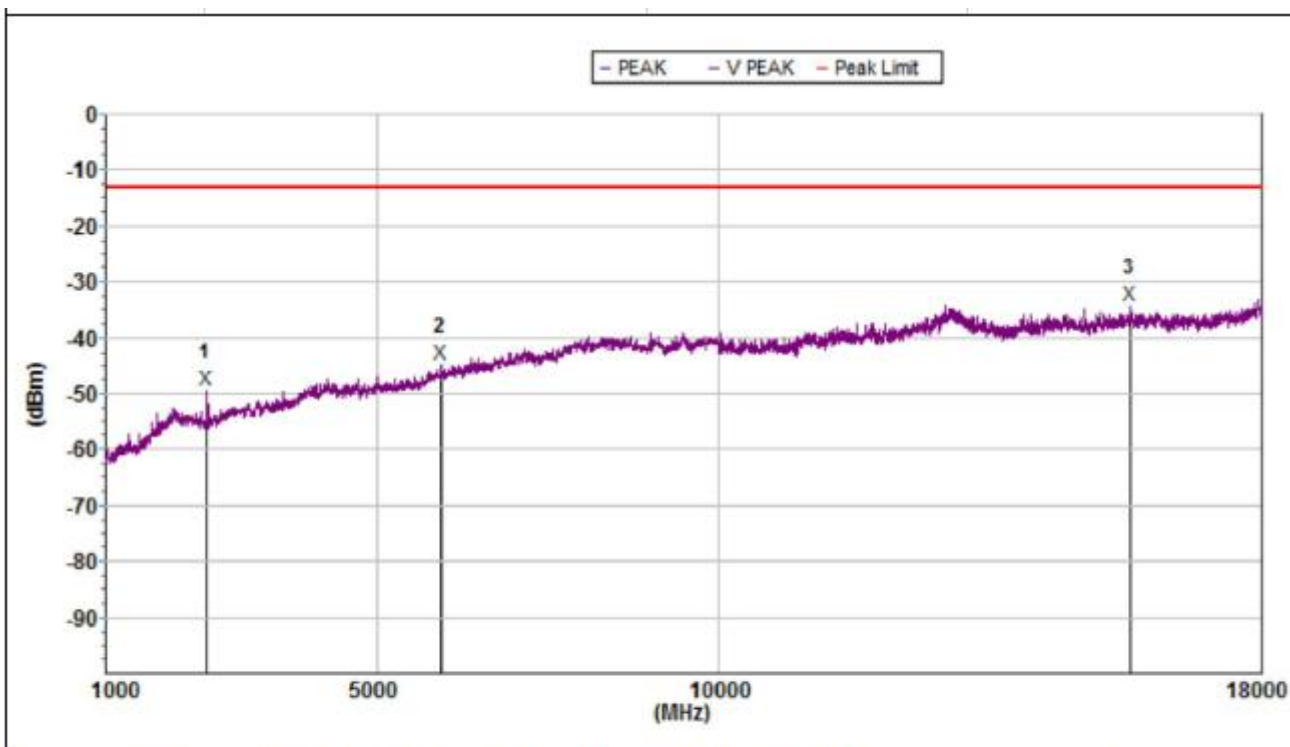

Mk.	Freq.(MHz)	Level(dBm)	Limit(dBm)	Margin(dB)	Deg.(deg.)	Hi(cm)	Factor(dB)	Pol.
Peak:								
1	2498.500	-49.2	-13.0	36.2	232.2	150	-9.2	V
2	5945.500	-44.8	-13.0	31.8	359.3	150	1.9	V
3	16072.000	-34.1	-13.0	21.1	0	150	14.0	V

NOTE: This document is issued by Shenzhen Morlab Communications Technology Co., Ltd., the test report shall not be reproduced except in full without prior written permission of the company. The test results apply only to the particular sample(s) tested and to the specific tests carried out which is available on request for validation and information confirmed at our website.



Test Mode	LTE Band 5_Traffic Mode_Low CH_Main antenna
Test Bandwidth	10MHz

Horizontal

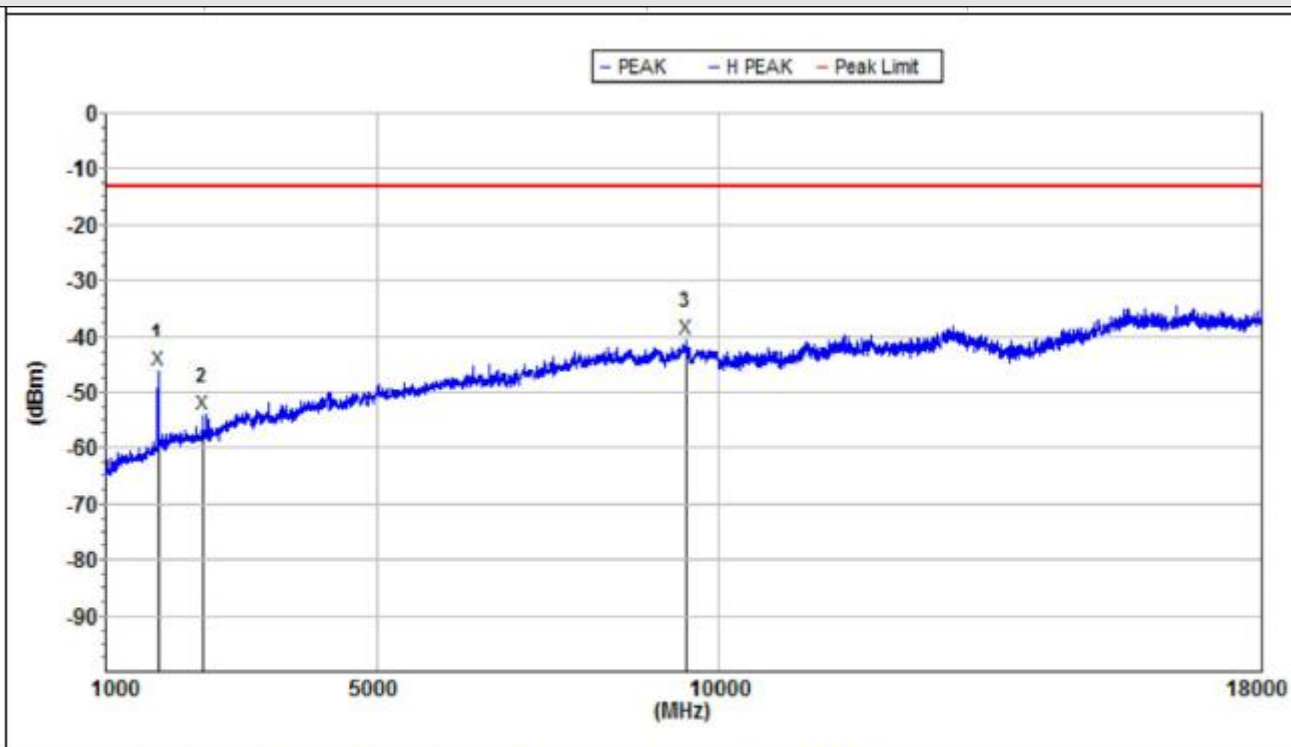

Mk.	Freq.(MHz)	Level(dBm)	Limit(dBm)	Margin(dB)	Deg.(deg.)	Hi(cm)	Factor(dB)	Pol.
Peak:								
1	1783.000	-46.2	-13.0	33.2	261.9	150	-13.0	H
2	2440.000	-53.8	-13.0	40.8	158	150	-11.8	H
3	9536.500	-40.5	-13.0	27.5	139.3	150	5.3	H

NOTE: This document is issued by Shenzhen Morlab Communications Technology Co., Ltd., the test report shall not be reproduced except in full without prior written permission of the company. The test results apply only to the particular sample(s) tested and to the specific tests carried out which is available on request for validation and information confirmed at our website.



Test Mode	LTE Band 5_Traffic Mode_Low CH_Main antenna
Test Bandwidth	10MHz

Vertical

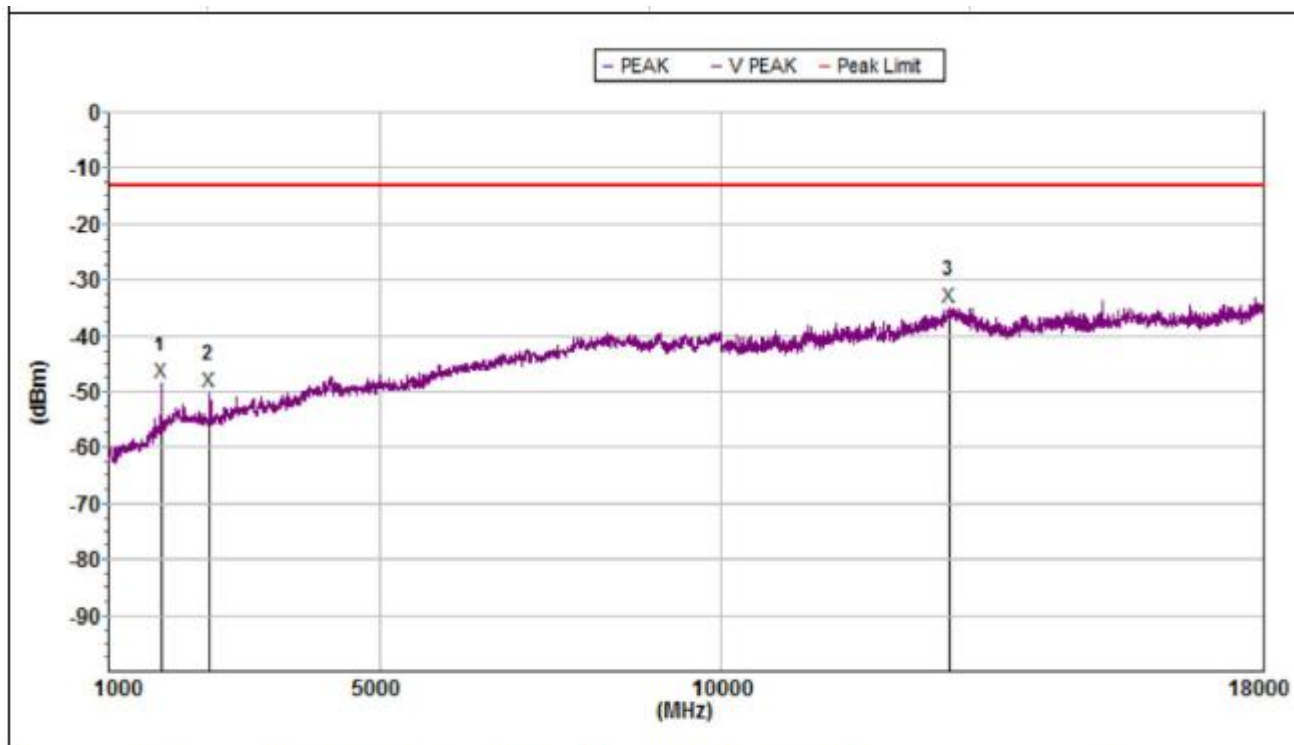

Mk.	Freq.(MHz)	Level(dBm)	Limit(dBm)	Margin(dB)	Deg.(deg.)	Hi(cm)	Factor(dB)	Pol.
Peak:								
1	1783.000	-48.2	-13.0	35.2	306.6	150	-10.0	V
2	2498.500	-49.9	-13.0	36.9	202.3	150	-9.2	V
3	13376.000	-35.0	-13.0	22.0	0.1	150	13.0	V

NOTE: This document is issued by Shenzhen Morlab Communications Technology Co., Ltd., the test report shall not be reproduced except in full without prior written permission of the company. The test results apply only to the particular sample(s) tested and to the specific tests carried out which is available on request for validation and information confirmed at our website.



Test Mode	LTE Band 7_Traffic Mode_High CH_Main antenna
Test Bandwidth	10MHz

Horizontal

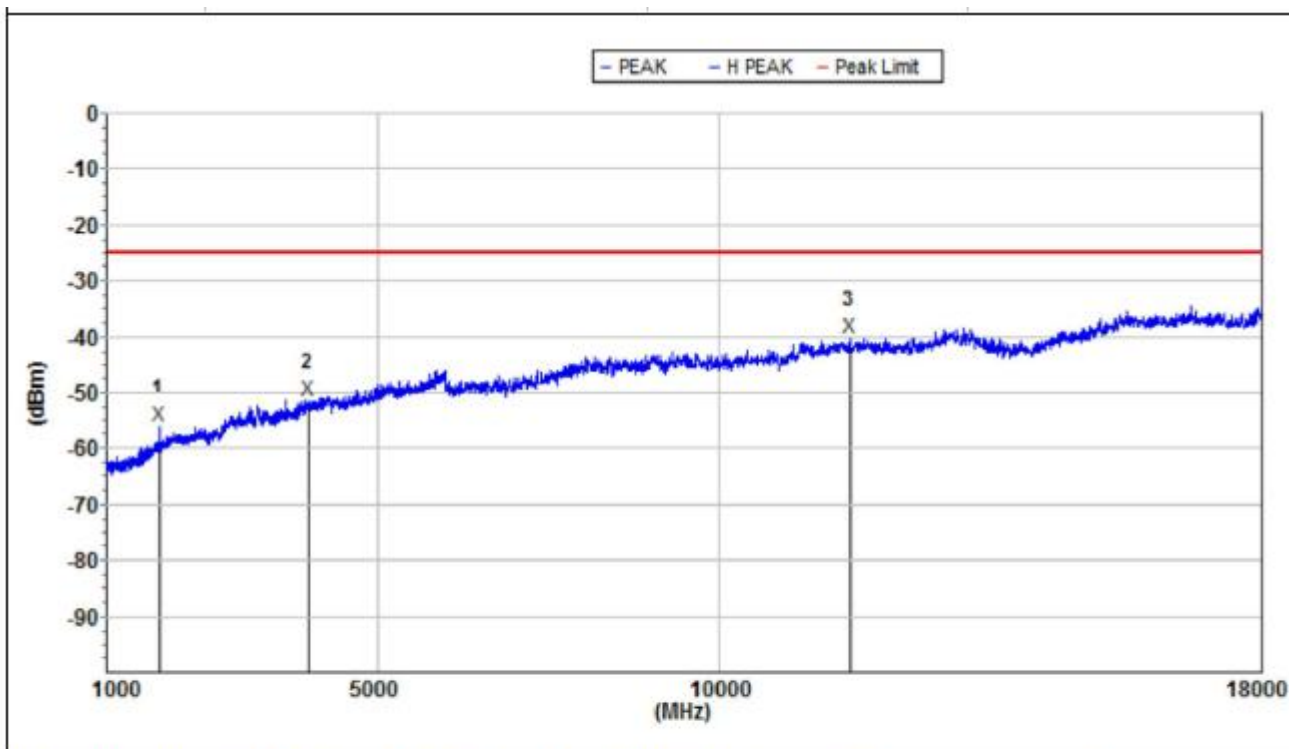

Mk.	Freq.(MHz)	Level(dBm)	Limit(dBm)	Margin(dB)	Deg.(deg.)	Hi.(cm)	Factor(dB)	Pol.
Peak:								
1	1775.000	-55.8	-25.0	30.8	129.1	150	-13.2	H
2	3975.000	-51.3	-25.0	26.3	129.1	150	-5.0	H
3	11940.000	-40.0	-25.0	15.0	359.9	150	8.1	H

NOTE: This document is issued by Shenzhen Morlab Communications Technology Co., Ltd., the test report shall not be reproduced except in full without prior written permission of the company. The test results apply only to the particular sample(s) tested and to the specific tests carried out which is available on request for validation and information confirmed at our website.



Test Mode	LTE Band 7_Traffic Mode_High CH_Main antenna
Test Bandwidth	10MHz

Vertical

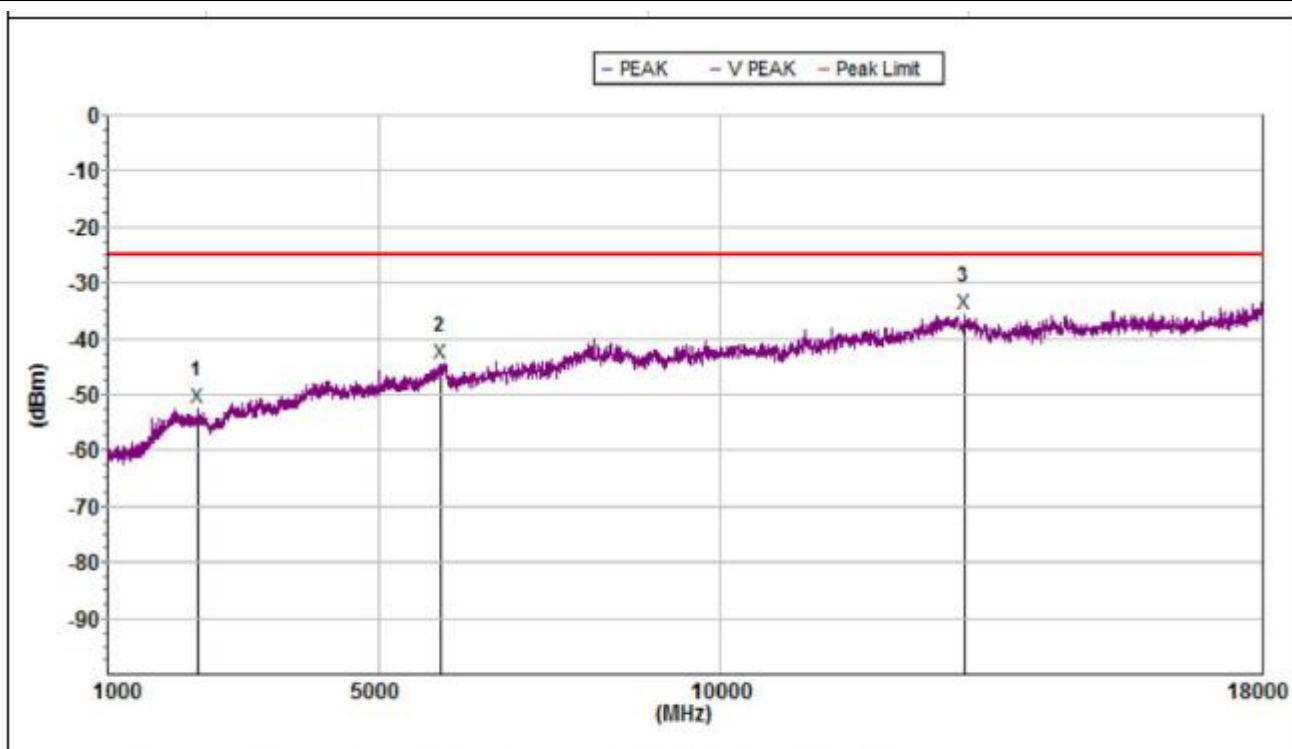

Mk.	Freq.(MHz)	Level(dBm)	Limit(dBm)	Margin(dB)	Deg.(deg.)	Hi(cm)	Factor(dB)	Pol.
Peak:								
1	2330.000	-52.3	-25.0	27.3	162.8	150	-8.2	V
2	5902.500	-44.4	-25.0	19.4	39.1	150	2.8	V
3	13608.000	-35.5	-25.0	10.5	0	150	12.9	V

NOTE: This document is issued by Shenzhen Morlab Communications Technology Co., Ltd., the test report shall not be reproduced except in full without prior written permission of the company. The test results apply only to the particular sample(s) tested and to the specific tests carried out which is available on request for validation and information confirmed at our website.



Test Mode	LTE Band 7_Traffic Mode_Mid CH_Main antenna
Test Bandwidth	10MHz

Horizontal

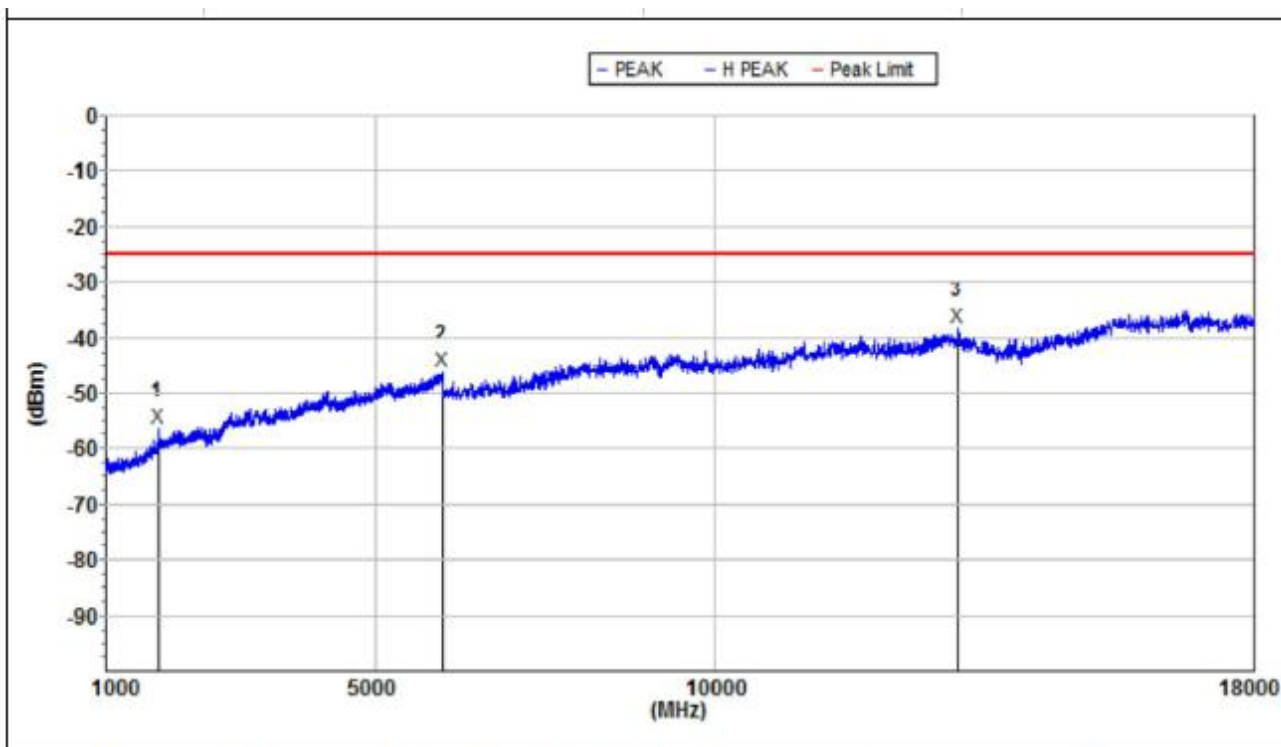

Mk.	Freq.(MHz)	Level(dBm)	Limit(dBm)	Margin(dB)	Deg.(deg.)	Hi.(cm)	Factor(dB)	Pol.
Peak:								
1	1785.000	-56.4	-25.0	31.4	73.2	150	-13.1	H
2	5982.500	-46.1	-25.0	21.1	34.9	150	0.3	H
3	13614.000	-38.2	-25.0	13.2	359.9	150	9.5	H

NOTE: This document is issued by Shenzhen Morlab Communications Technology Co., Ltd., the test report shall not be reproduced except in full without prior written permission of the company. The test results apply only to the particular sample(s) tested and to the specific tests carried out which is available on request for validation and information confirmed at our website.



Test Mode	LTE Band 7_Traffic Mode_Mid CH_Main antenna
Test Bandwidth	10MHz

Vertical

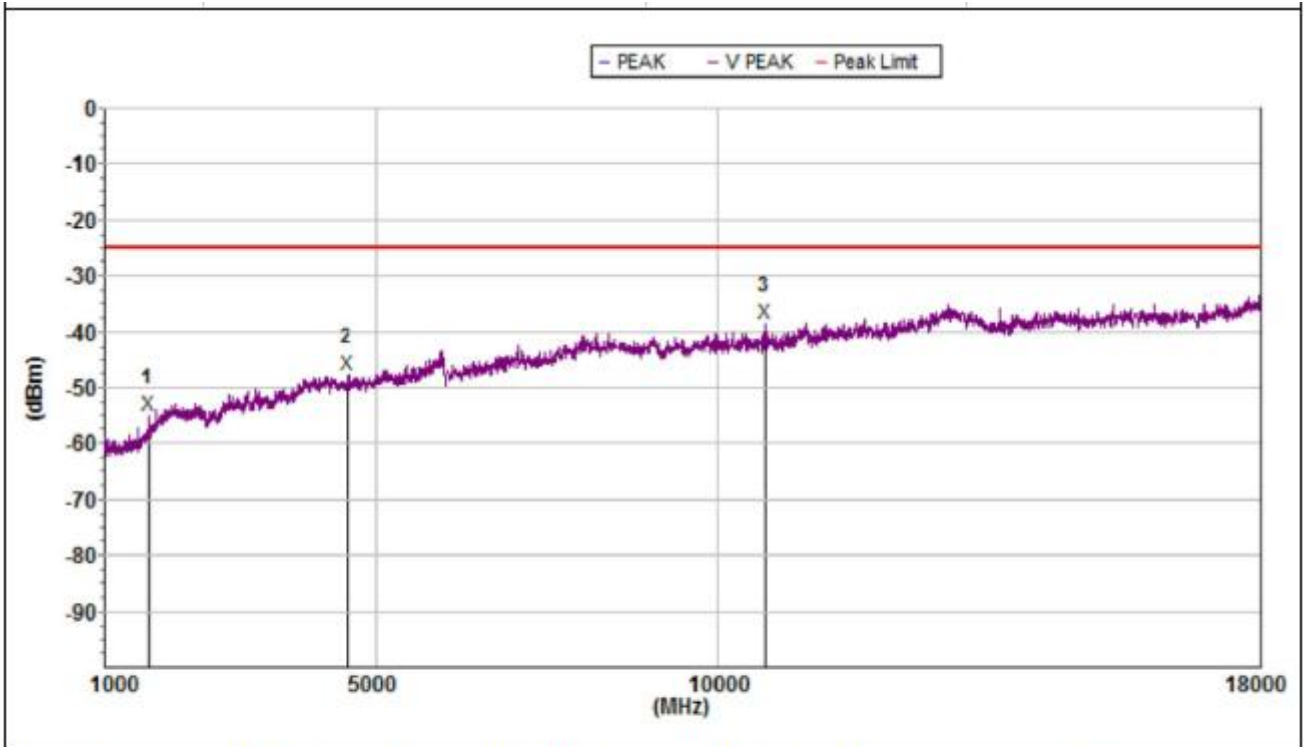

Mk.	Freq.(MHz)	Level(dBm)	Limit(dBm)	Margin(dB)	De (+)	Hi (cm)	Factor(dB)	Pol.
Peak:								
1	1665.000	-54.8	-25.0	29.8	220.2	150	-11.8	V
2	4577.500	-47.6	-25.0	22.6	66.8	150	-1.5	V
3	10704.000	-38.4	-25.0	13.4	359.3	150	8.1	V

NOTE: This document is issued by Shenzhen Morlab Communications Technology Co., Ltd., the test report shall not be reproduced except in full without prior written permission of the company. The test results apply only to the particular sample(s) tested and to the specific tests carried out which is available on request for validation and information confirmed at our website.



Test Mode	LTE Band 7_Traffic Mode_Low CH_Main antenna
Test Bandwidth	10MHz

Horizontal

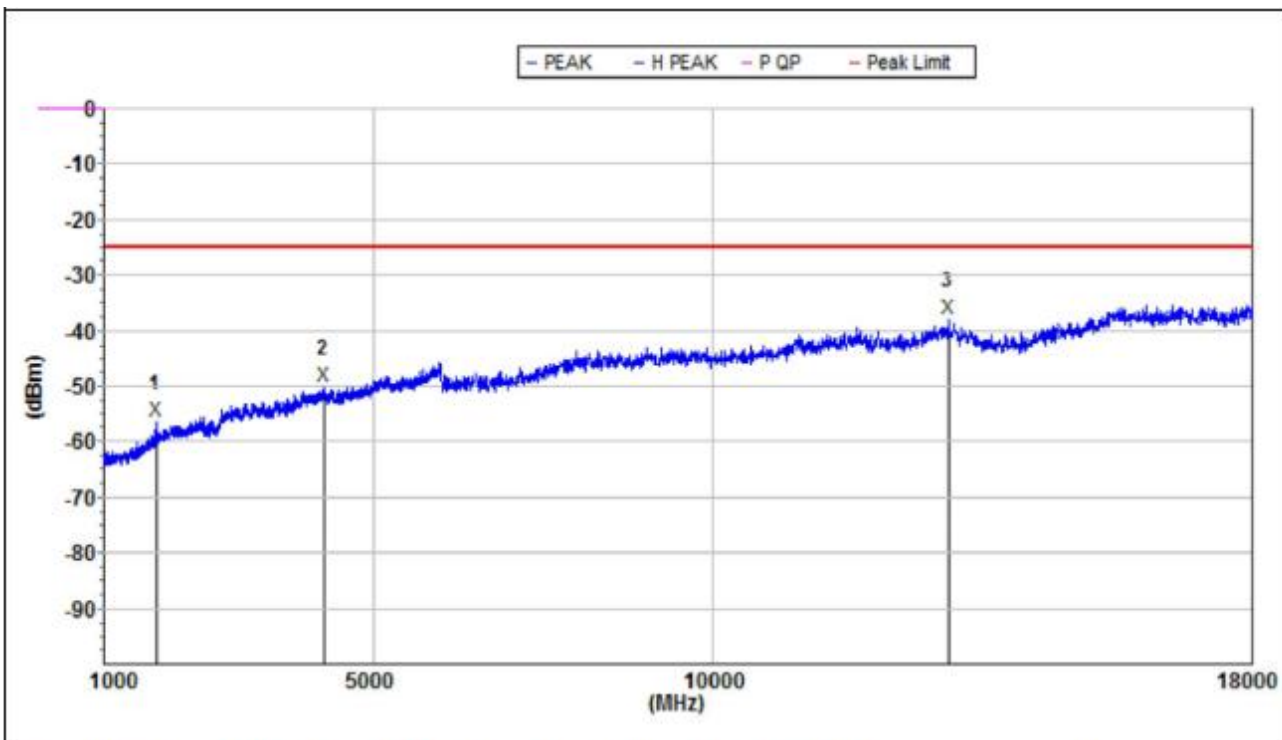

Mk	Freq.(MHz)	Level(dBm)	Limit(dBm)	Margin(dB)	Deg.(deg.)	Hi(cm)	Factor(dB)	Pol.
Peak:								
1	1772.500	-56.2	-25.0	31.2	305.4	150	-13.2	H
2	4267.500	-50.0	-25.0	25.0	360	150	-4.8	H
3	13500.000	-37.9	-25.0	12.9	0	150	10.0	H

NOTE: This document is issued by Shenzhen Morlab Communications Technology Co., Ltd., the test report shall not be reproduced except in full without prior written permission of the company. The test results apply only to the particular sample(s) tested and to the specific tests carried out which is available on request for validation and information confirmed at our website.



Test Mode	LTE Band 7_Traffic Mode_Low CH_Main antenna
Test Bandwidth	10MHz

Vertical

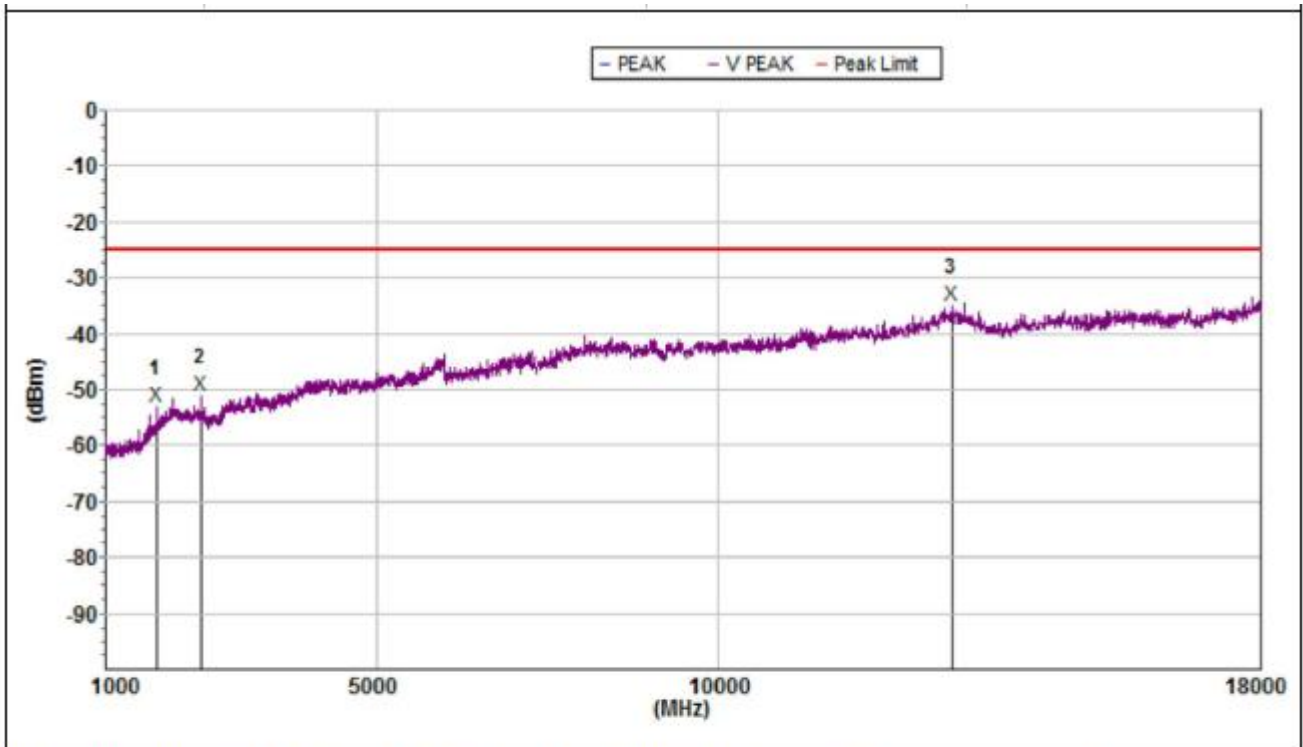

Mk.	Freq.(MHz)	Level(dBm)	Limit(dBm)	Margin(dB)	Deg.(deg.)	Hi(cm)	Factor(dB)	Pol.
Peak:								
1	1750.000	-52.9	-25.0	27.9	169.2	150	-10.5	V
2	2420.000	-51.1	-25.0	26.1	264.8	150	-8.5	V
3	13446.000	-35.0	-25.0	10.0	360	150	13.3	V

NOTE: This document is issued by Shenzhen Morlab Communications Technology Co., Ltd., the test report shall not be reproduced except in full without prior written permission of the company. The test results apply only to the particular sample(s) tested and to the specific tests carried out which is available on request for validation and information confirmed at our website.



Test Mode	LTE Band 12_Traffic Mode_High CH_Main antenna
Test Bandwidth	10MHz

Horizontal

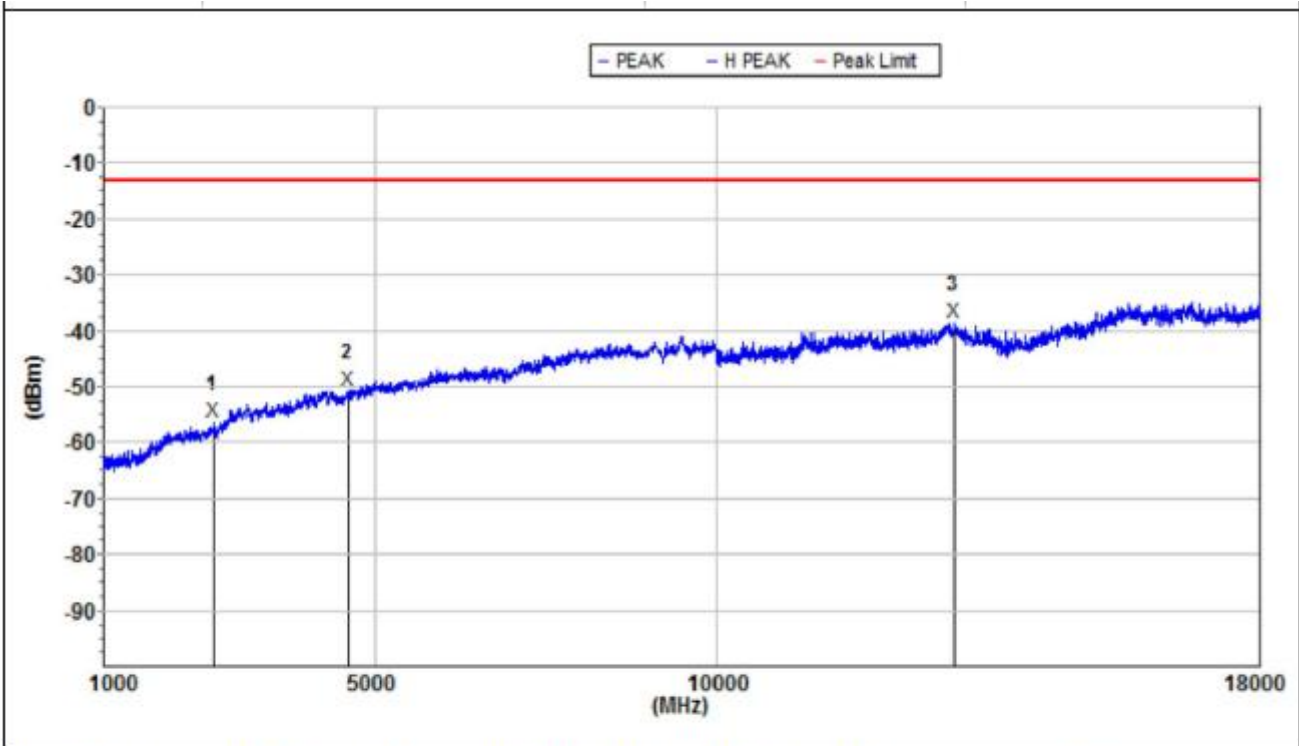

Mk.	Freq.(MHz)	Level(dBm)	Limit(dBm)	Margin(dB)	Deg.(deg.)	Hi(cm)	Factor(dB)	Pol.
Peak:								
1	2611.000	-56.3	-13.0	43.3	82.1	150	-11.0	H
2	4609.000	-50.7	-13.0	37.7	360	150	-3.9	H
3	13504.000	-38.4	-13.0	25.4	360	150	10.0	H

NOTE: This document is issued by Shenzhen Morlab Communications Technology Co., Ltd., the test report shall not be reproduced except in full without prior written permission of the company. The test results apply only to the particular sample(s) tested and to the specific tests carried out which is available on request for validation and information confirmed at our website.



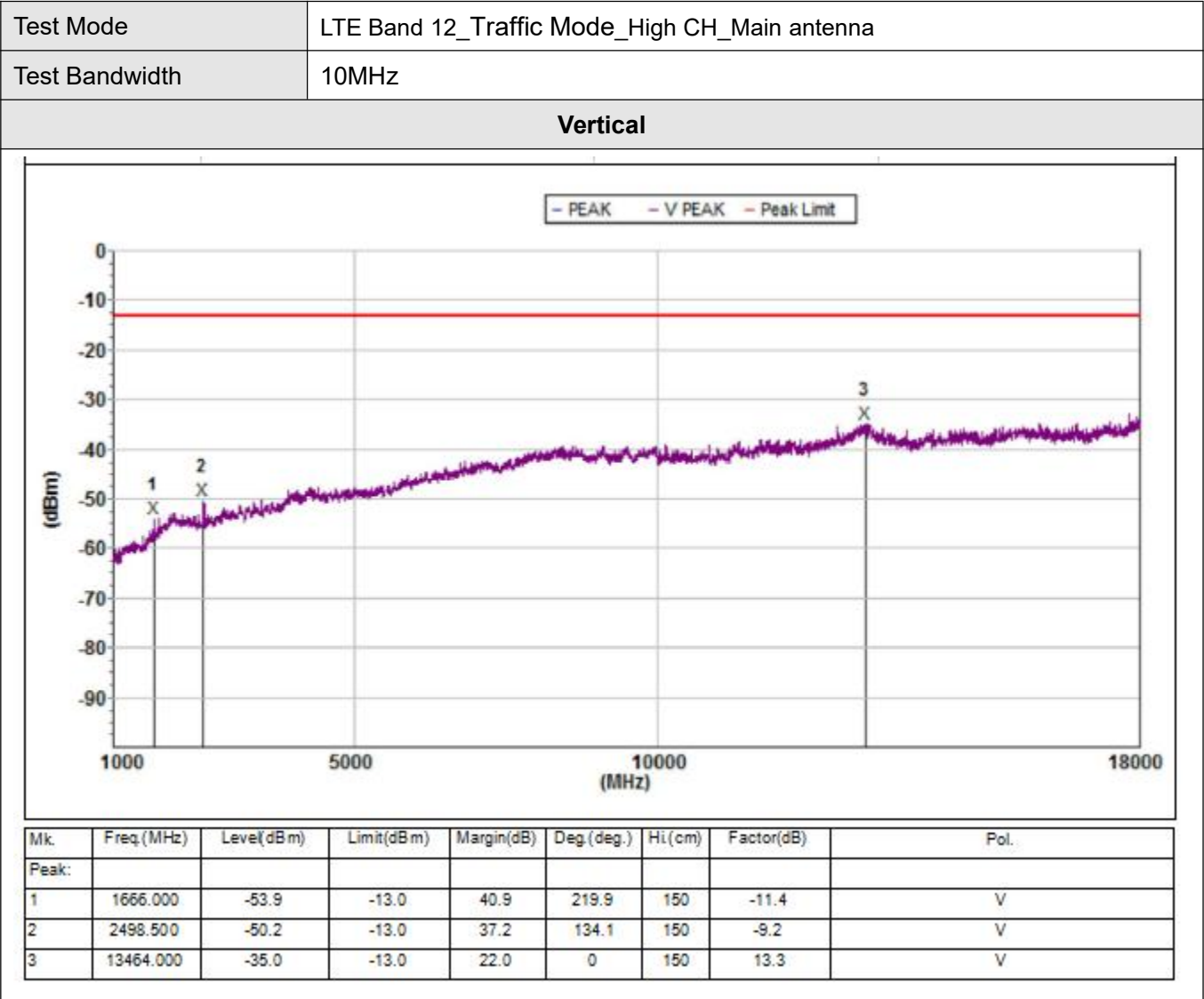

NOTE: This document is issued by Shenzhen Morlab Communications Technology Co., Ltd., the test report shall not be reproduced except in full without prior written permission of the company. The test results apply only to the particular sample(s) tested and to the specific tests carried out which is available on request for validation and information confirmed at our website.



Test Mode	LTE Band 12_Traffic Mode_Mid CH_Main antenna
Test Bandwidth	10MHz

Horizontal

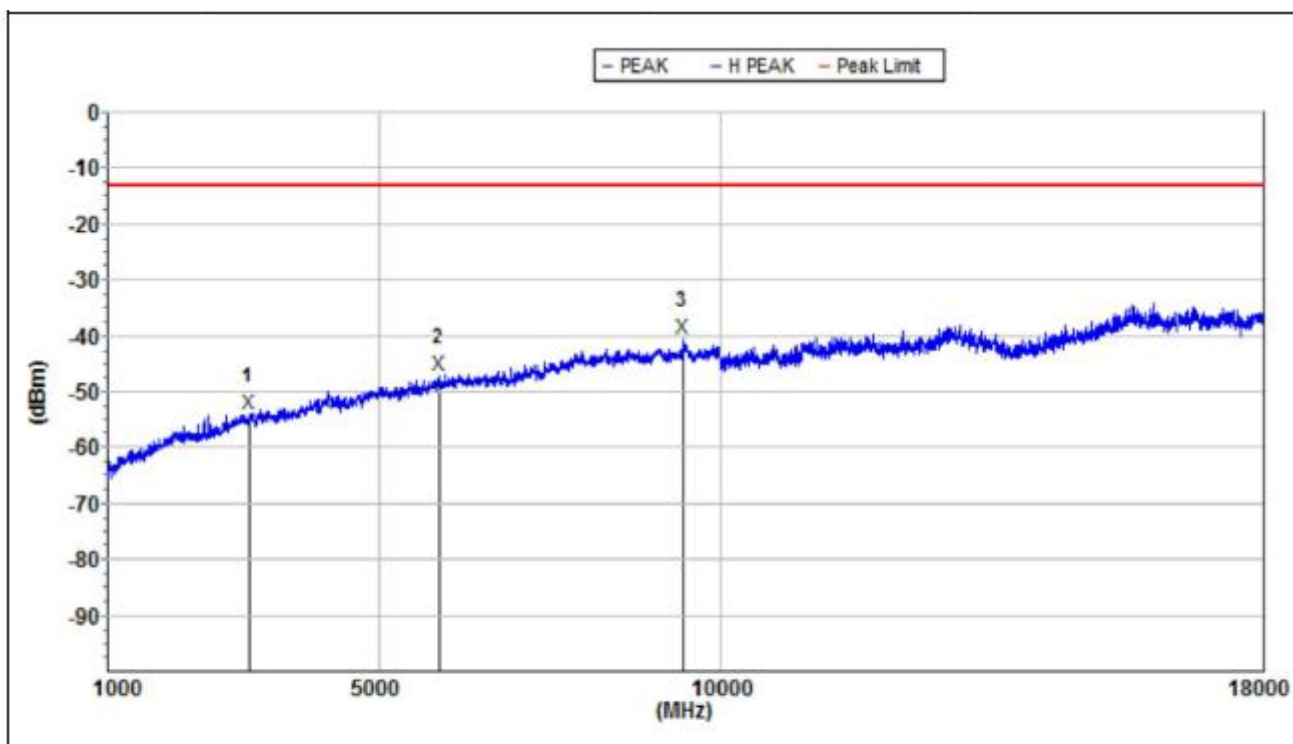

Mk.	Freq.(MHz)	Level(dBm)	Limit(dBm)	Margin(dB)	Deg.(deg.)	Hi.(cm)	Factor(dB)	Pol.
Peak:								
1	3083.500	-53.8	-13.0	40.8	330.9	150	-8.2	H
2	5873.500	-47.2	-13.0	34.2	340.3	150	-0.5	H
3	9464.500	-40.5	-13.0	27.5	130.1	150	5.3	H

NOTE: This document is issued by Shenzhen Morlab Communications Technology Co., Ltd., the test report shall not be reproduced except in full without prior written permission of the company. The test results apply only to the particular sample(s) tested and to the specific tests carried out which is available on request for validation and information confirmed at our website.



Test Mode	LTE Band 12_Traffic Mode_Mid CH_Main antenna
Test Bandwidth	10MHz

Vertical

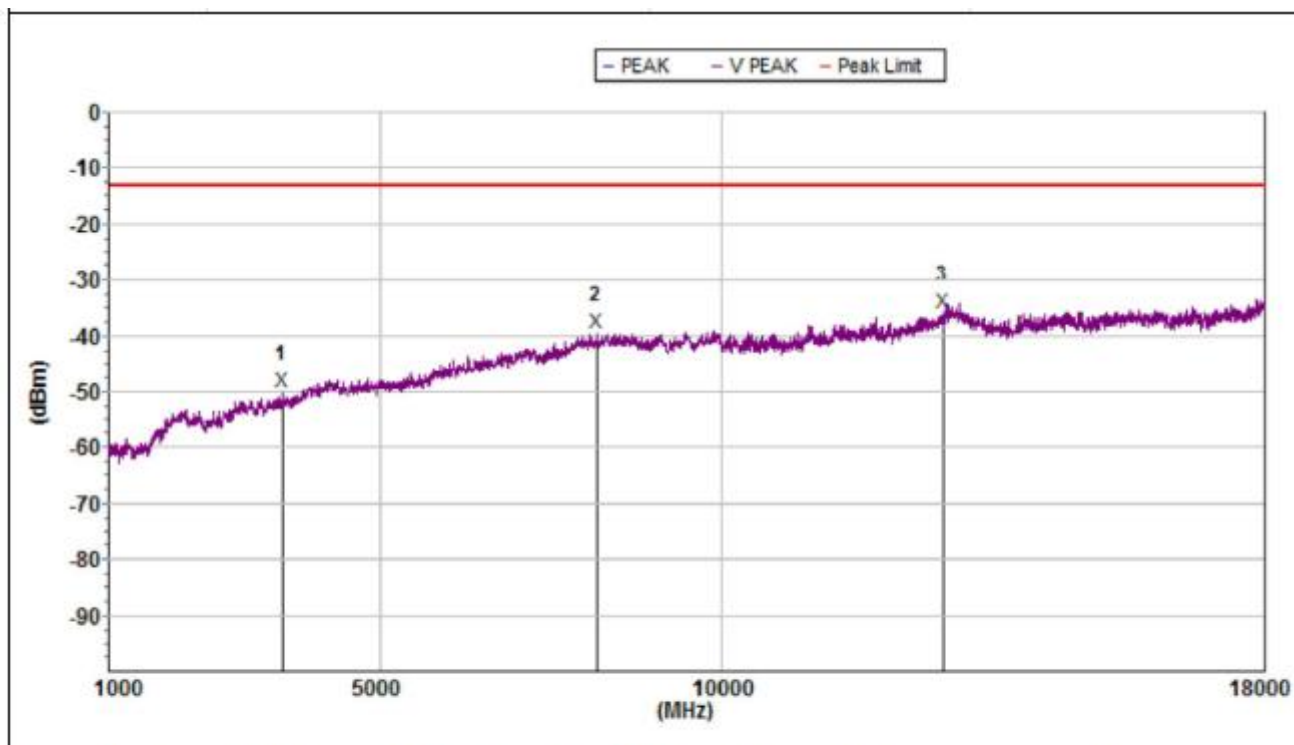

Mk	Freq.(MHz)	Level(dBm)	Limit(dBm)	Margin(dB)	Deg.(deg.)	Hi(cm)	Factor(dB)	Pol.
Peak:								
1	3551.500	-49.9	-13.0	36.9	220.6	150	-5.6	V
2	8168.500	-39.5	-13.0	26.5	182.8	150	7.1	V
3	13280.000	-35.7	-13.0	22.7	0.2	150	12.5	V

NOTE: This document is issued by Shenzhen Morlab Communications Technology Co., Ltd., the test report shall not be reproduced except in full without prior written permission of the company. The test results apply only to the particular sample(s) tested and to the specific tests carried out which is available on request for validation and information confirmed at our website.



Test Mode	LTE Band 12_Traffic Mode_Low CH_Main antenna
Test Bandwidth	10MHz

Horizontal

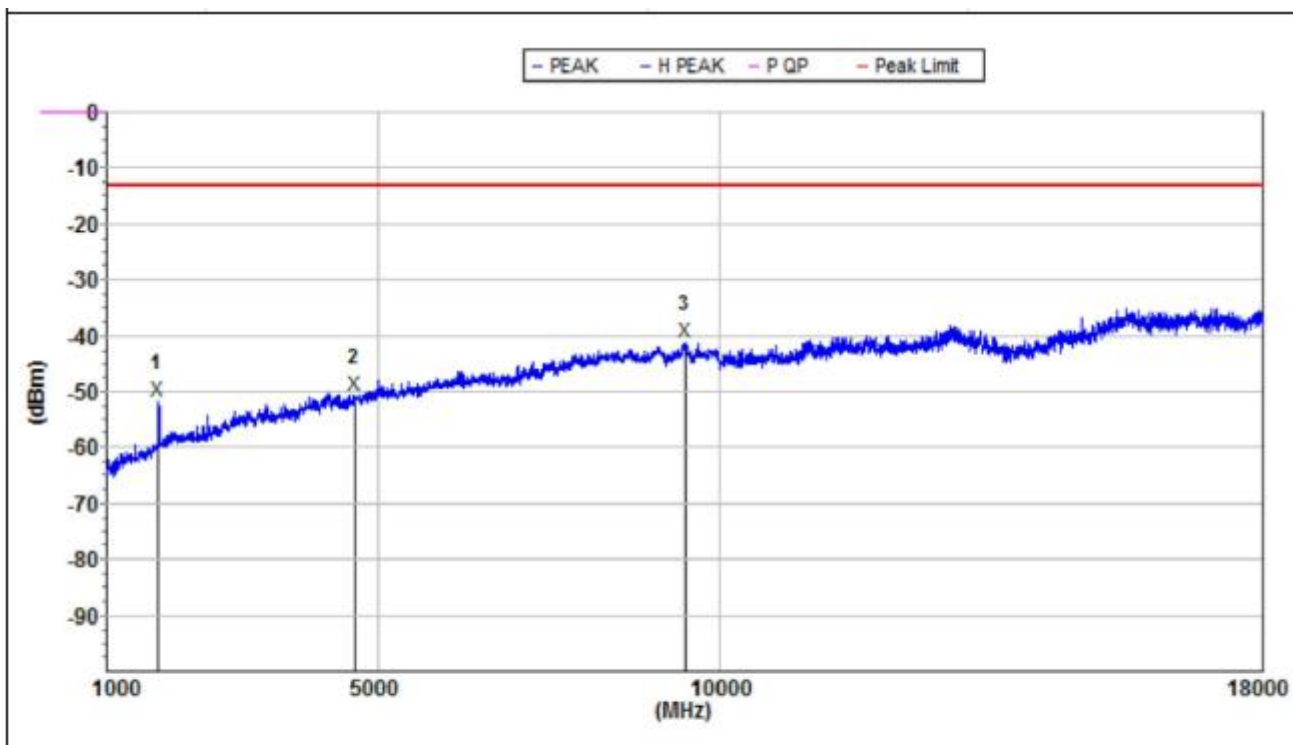

Mk.	Freq (MHz)	Level(dBm)	Limit(dBm)	Margin(dB)	Deg. (deg.)	Hi. (cm)	Factor(dB)	Pol.
Peak:								
1	1769.500	-51.6	-13.0	38.6	0	150	-13.2	H
2	4645.000	-50.5	-13.0	37.5	289.3	150	-3.7	H
3	9500.500	-41.2	-13.0	28.2	222.9	150	5.3	H

NOTE: This document is issued by Shenzhen Morlab Communications Technology Co., Ltd., the test report shall not be reproduced except in full without prior written permission of the company. The test results apply only to the particular sample(s) tested and to the specific tests carried out which is available on request for validation and information confirmed at our website.



Test Mode	LTE Band 12_Traffic Mode_Low CH_Main antenna
Test Bandwidth	10MHz

Vertical

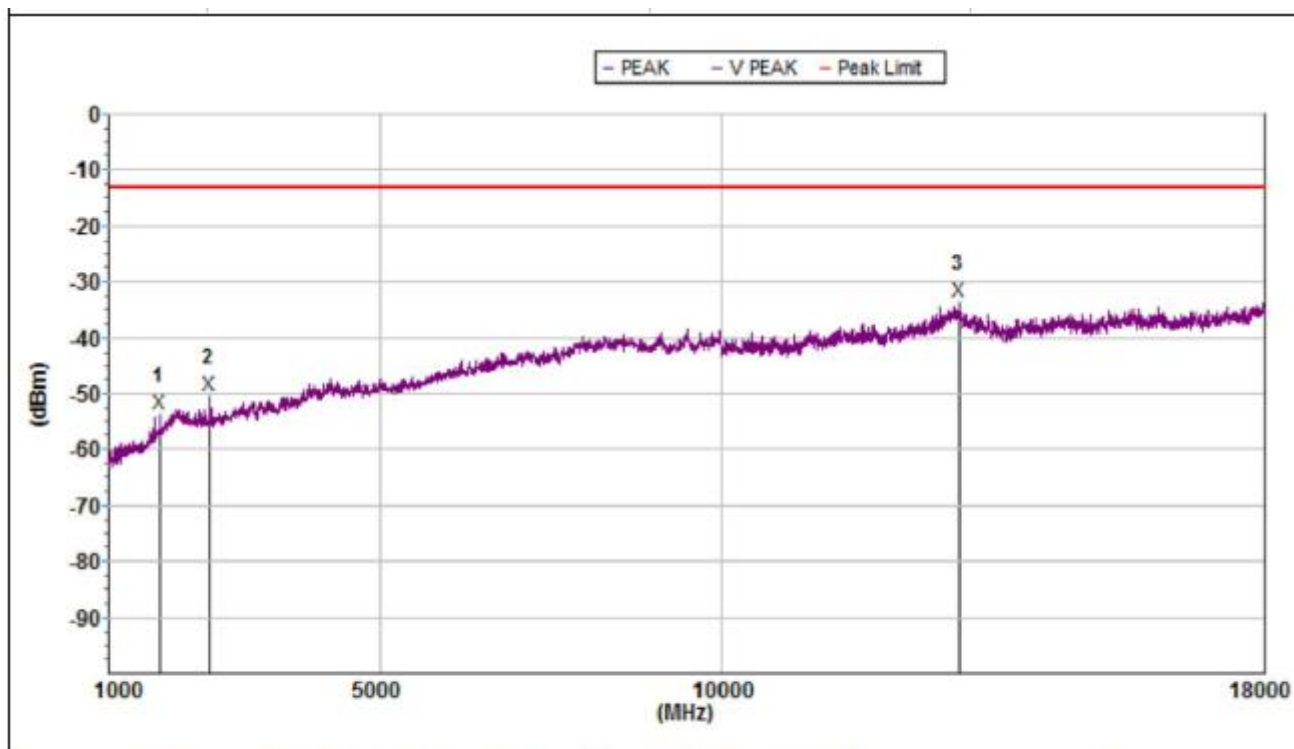

Mk.	Freq.(MHz)	Level(dBm)	Limit(dBm)	Margin(dB)	Deg.(deg.)	Hi(cm)	Factor(dB)	Pol.
Peak:								
1	1751.500	-53.7	-13.0	40.7	174.4	150	-10.4	V
2	2498.500	-50.2	-13.0	37.2	202.5	150	-9.2	V
3	13504.000	-33.4	-13.0	20.4	0.4	150	13.5	V

NOTE: This document is issued by Shenzhen Morlab Communications Technology Co., Ltd., the test report shall not be reproduced except in full without prior written permission of the company. The test results apply only to the particular sample(s) tested and to the specific tests carried out which is available on request for validation and information confirmed at our website.



Test Mode	LTE Band 17_Traffic Mode_High CH_Main antenna
Test Bandwidth	10MHz

Horizontal

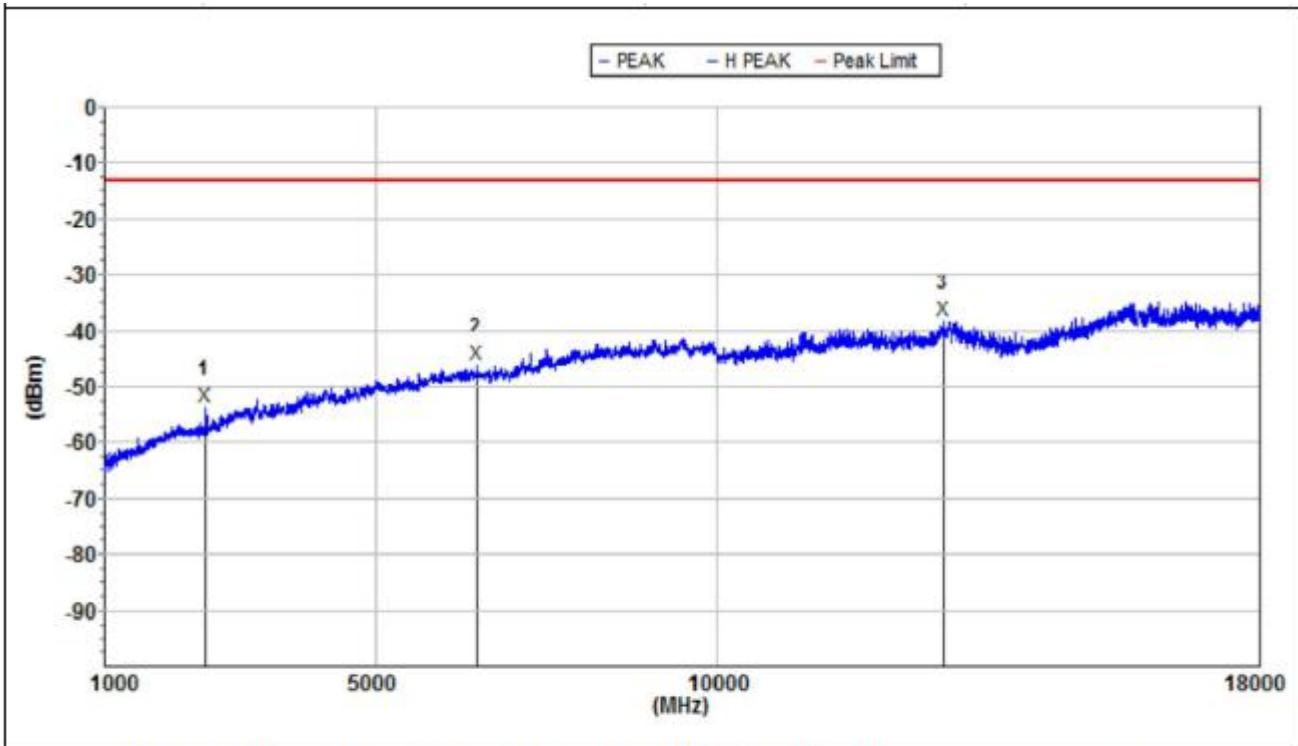

Mk	Freq.(MHz)	Leve(dBm)	Limit(dBm)	Margin(dB)	Deg.(deg.)	Hi(cm)	Factor(dB)	Pol.
Peak:								
1	2498.500	-53.7	-13.0	40.7	48.4	150	-11.8	H
2	6481.000	-46.2	-13.0	33.2	229.9	150	0.8	H
3	13356.000	-38.0	-13.0	25.0	0	150	9.3	H

NOTE: This document is issued by Shenzhen Morlab Communications Technology Co., Ltd., the test report shall not be reproduced except in full without prior written permission of the company. The test results apply only to the particular sample(s) tested and to the specific tests carried out which is available on request for validation and information confirmed at our website.



Test Mode	LTE Band 17_Traffic Mode_High CH_Main antenna
Test Bandwidth	10MHz

Vertical

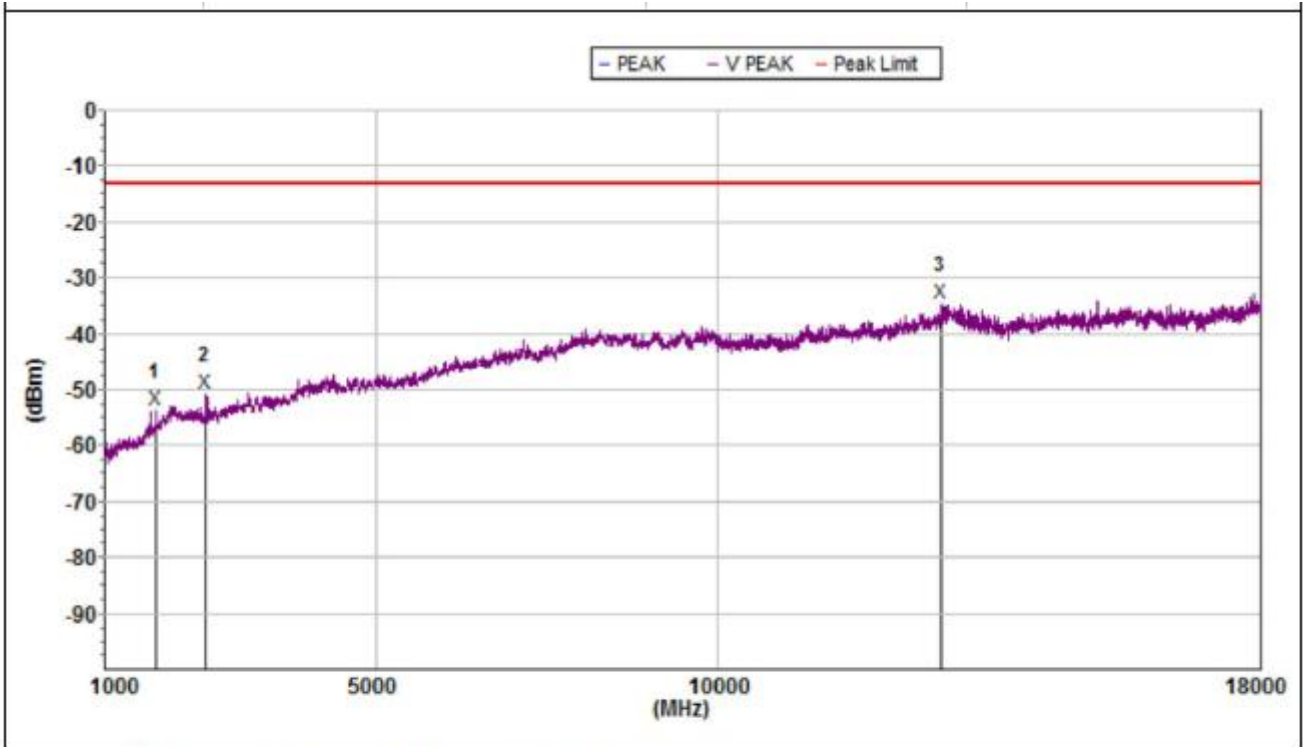

Mk.	Freq.(MHz)	Level(dBm)	Limit(dBm)	Margin(dB)	Deg.(deg.)	Hi(cm)	Factor(dB)	Pol.
Peak:								
1	1751.500	-53.7	-13.0	40.7	187.8	150	-10.4	V
2	2498.500	-50.6	-13.0	37.6	187.8	150	-9.2	V
3	13292.000	-34.4	-13.0	21.4	359.9	150	12.6	V

NOTE: This document is issued by Shenzhen Morlab Communications Technology Co., Ltd., the test report shall not be reproduced except in full without prior written permission of the company. The test results apply only to the particular sample(s) tested and to the specific tests carried out which is available on request for validation and information confirmed at our website.



Test Mode	LTE Band 17_Traffic Mode_Mid CH_Main antenna
Test Bandwidth	10MHz

Horizontal

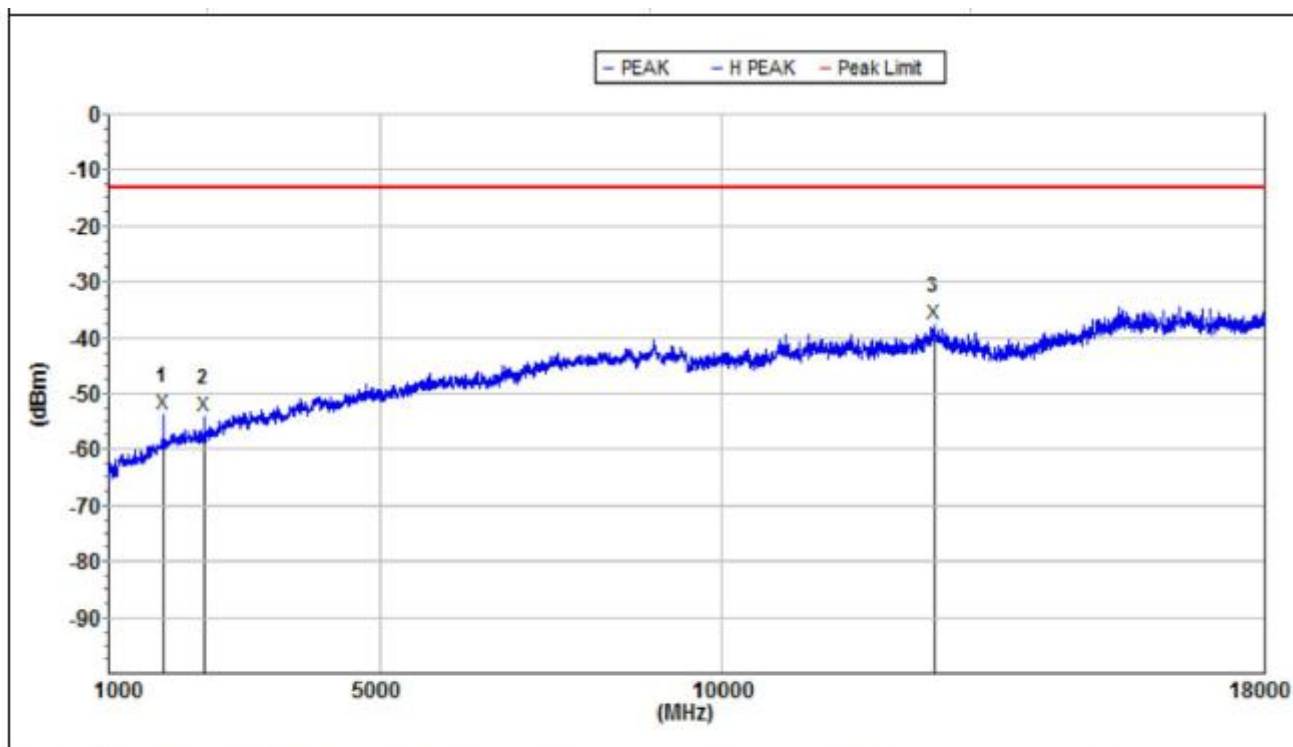

Mk.	Freq (MHz)	Level(dBm)	Limit(dBm)	Margin(dB)	De +)	Hi (cm)	Factor(dB)	Pol.
Peak:								
1	1803.250	-53.7	-13.0	40.7	239.77	150	34.2	H
2	2415.250	-53.9	-13.0	40.9	48.52	150	33.3	H
3	13146.500	-37.6	-13.0	24.6	0	150	8.4	H

NOTE: This document is issued by Shenzhen Morlab Communications Technology Co., Ltd., the test report shall not be reproduced except in full without prior written permission of the company. The test results apply only to the particular sample(s) tested and to the specific tests carried out which is available on request for validation and information confirmed at our website.



Test Mode	LTE Band 17_Traffic Mode_Mid CH_Main antenna
Test Bandwidth	10MHz

Vertical

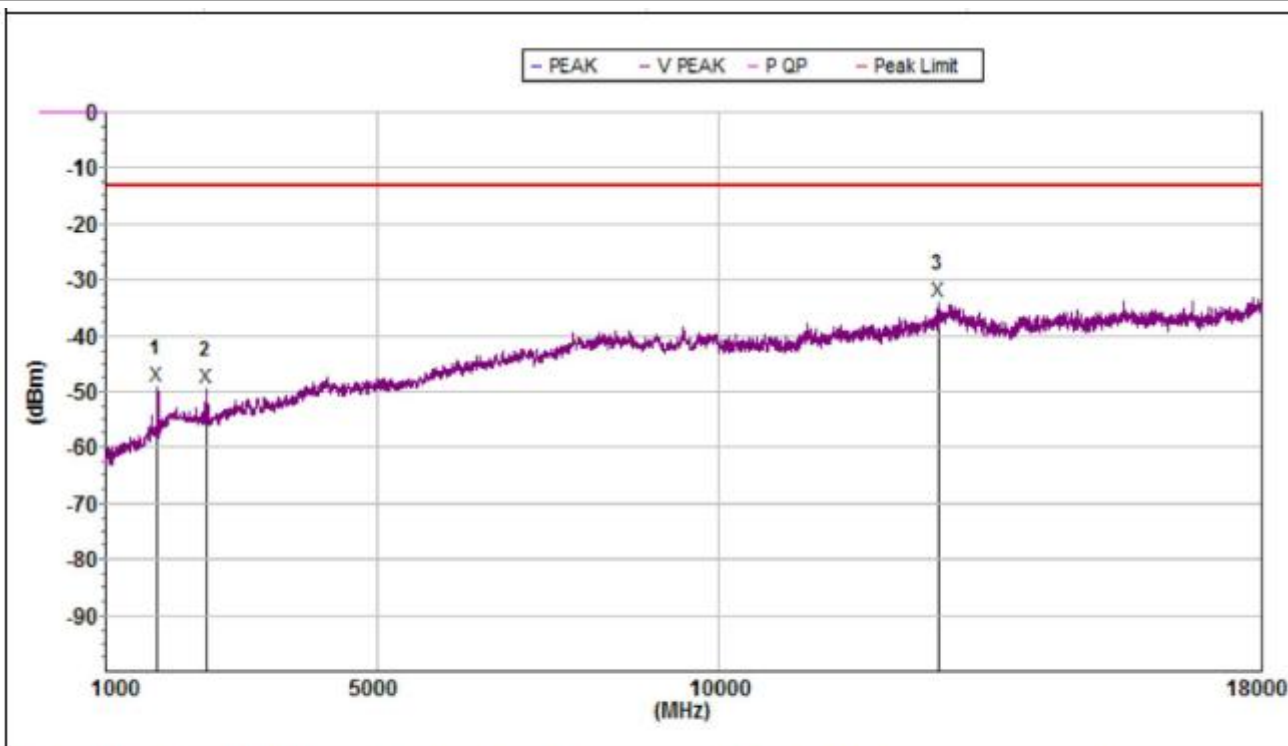

Mk.	Freq.(MHz)	Level(dBm)	Limit(dBm)	Margin(dB)	De	Hi(cm)	Factor(dB)	Pol.
Peak:					+			
1	1769.500	-49.1	-13.0	36.1	353.6	150	-10.2	V
2	2498.500	-49.3	-13.0	36.3	237.3	150	-9.2	V
3	13252.000	-33.8	-13.0	20.8	359.2	150	12.5	V

NOTE: This document is issued by Shenzhen Morlab Communications Technology Co., Ltd., the test report shall not be reproduced except in full without prior written permission of the company. The test results apply only to the particular sample(s) tested and to the specific tests carried out which is available on request for validation and information confirmed at our website.



Test Mode	LTE Band 17_Traffic Mode_Low CH_Main antenna
Test Bandwidth	10MHz

Horizontal

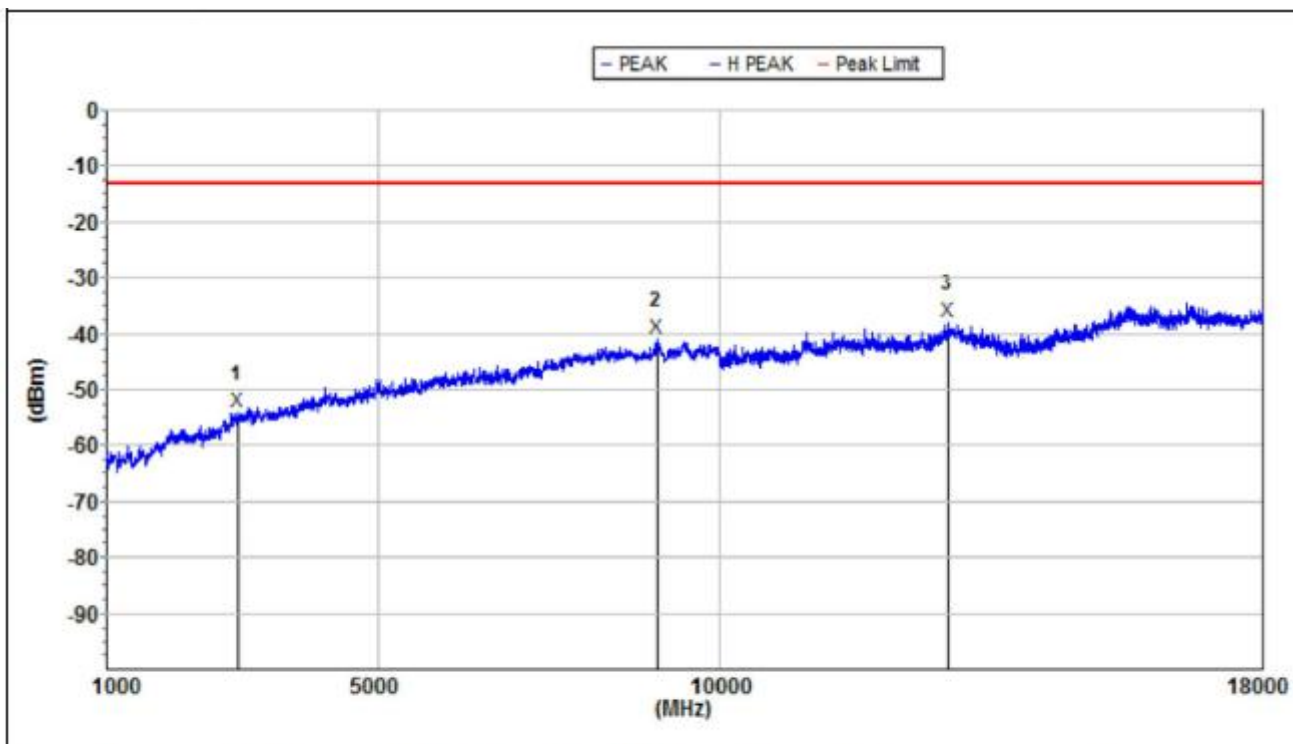

Mk.	Freq.(MHz)	Level(dBm)	Limit(dBm)	Margin(dB)	Deg.(deg.)	Hi.(cm)	Factor(dB)	Pol.
Peak:								
1	2944.000	-54.0	-13.0	41.0	332.2	150	-8.6	H
2	9086.500	-40.8	-13.0	27.8	153	150	4.5	H
3	13380.000	-37.9	-13.0	24.9	0.1	150	9.5	H

NOTE: This document is issued by Shenzhen Morlab Communications Technology Co., Ltd., the test report shall not be reproduced except in full without prior written permission of the company. The test results apply only to the particular sample(s) tested and to the specific tests carried out which is available on request for validation and information confirmed at our website.



Test Mode	LTE Band 17_Traffic Mode_Low CH_Main antenna
Test Bandwidth	10MHz

Vertical

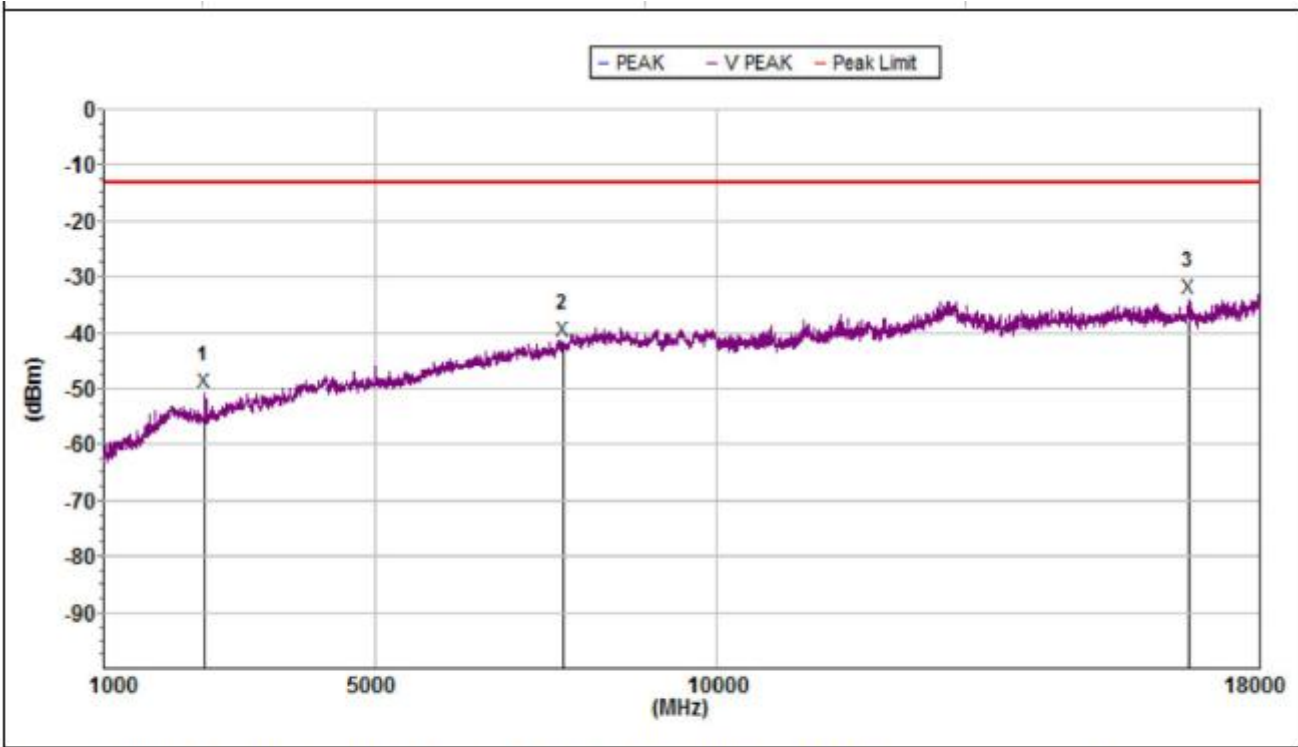

Mk.	Freq.(MHz)	Level(dBm)	Limit(dBm)	Margin(dB)	Deg.(deg.)	Hi.(cm)	Factor(dB)	Pol.
Peak:								
1	2498.500	-50.5	-13.0	37.5	160.6	150	-9.2	V
2	7768.000	-41.3	-13.0	28.3	6.7	150	6.2	V
3	16964.000	-33.8	-13.0	20.8	360	150	13.8	V

NOTE: This document is issued by Shenzhen Morlab Communications Technology Co., Ltd., the test report shall not be reproduced except in full without prior written permission of the company. The test results apply only to the particular sample(s) tested and to the specific tests carried out which is available on request for validation and information confirmed at our website.



Test Mode	LTE Band 41_Traffic Mode_High CH_Main antenna
Test Bandwidth	20MHz

Horizontal

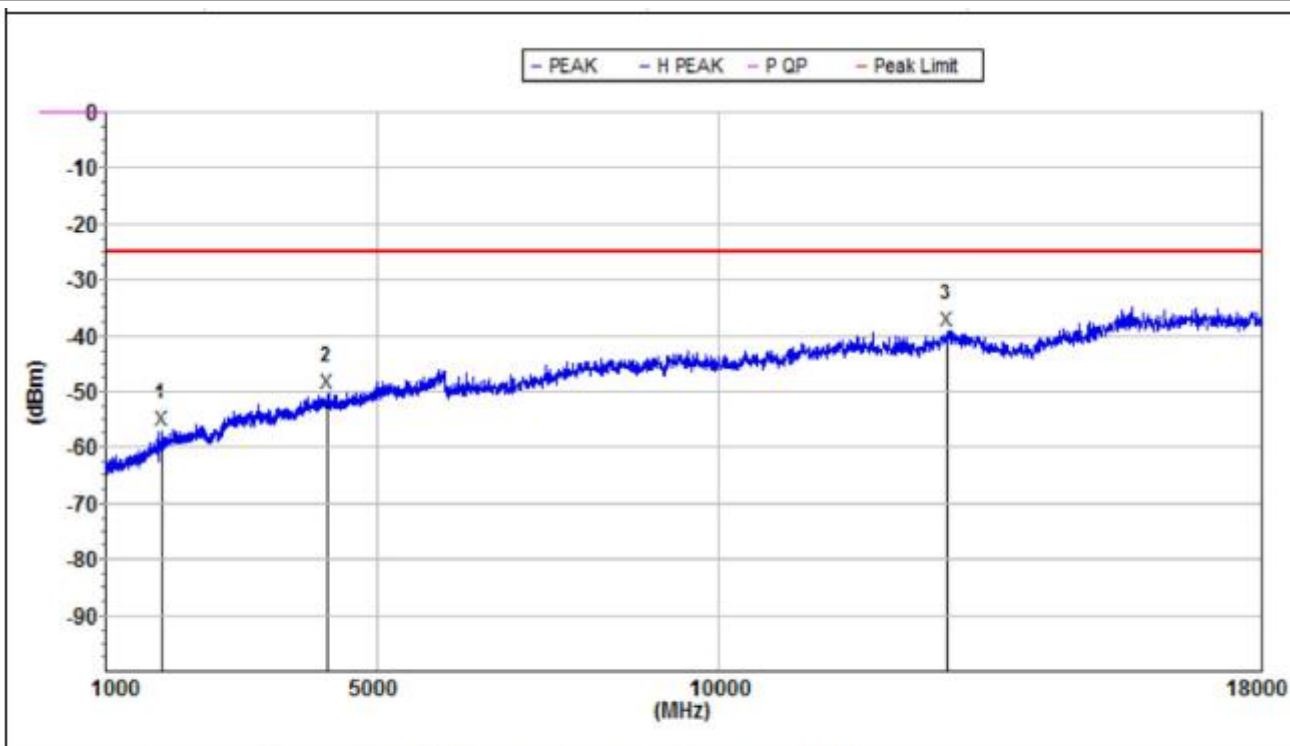

Mk.	Freq.(MHz)	Level(dBm)	Limit(dBm)	Margin(dB)	Deg.(deg.)	Hi.(cm)	Factor(dB)	Pol.
Peak:								
1	1842.500	-57.0	-25.0	32.0	267.6	150	-12.7	H
2	4265.000	-50.2	-25.0	25.2	344	150	-4.8	H
3	13368.000	-39.0	-25.0	14.0	0.6	150	9.4	H

NOTE: This document is issued by Shenzhen Morlab Communications Technology Co., Ltd., the test report shall not be reproduced except in full without prior written permission of the company. The test results apply only to the particular sample(s) tested and to the specific tests carried out which is available on request for validation and information confirmed at our website.



Test Mode	LTE Band 41_Traffic Mode_High CH_Main antenna
Test Bandwidth	20MHz

Vertical

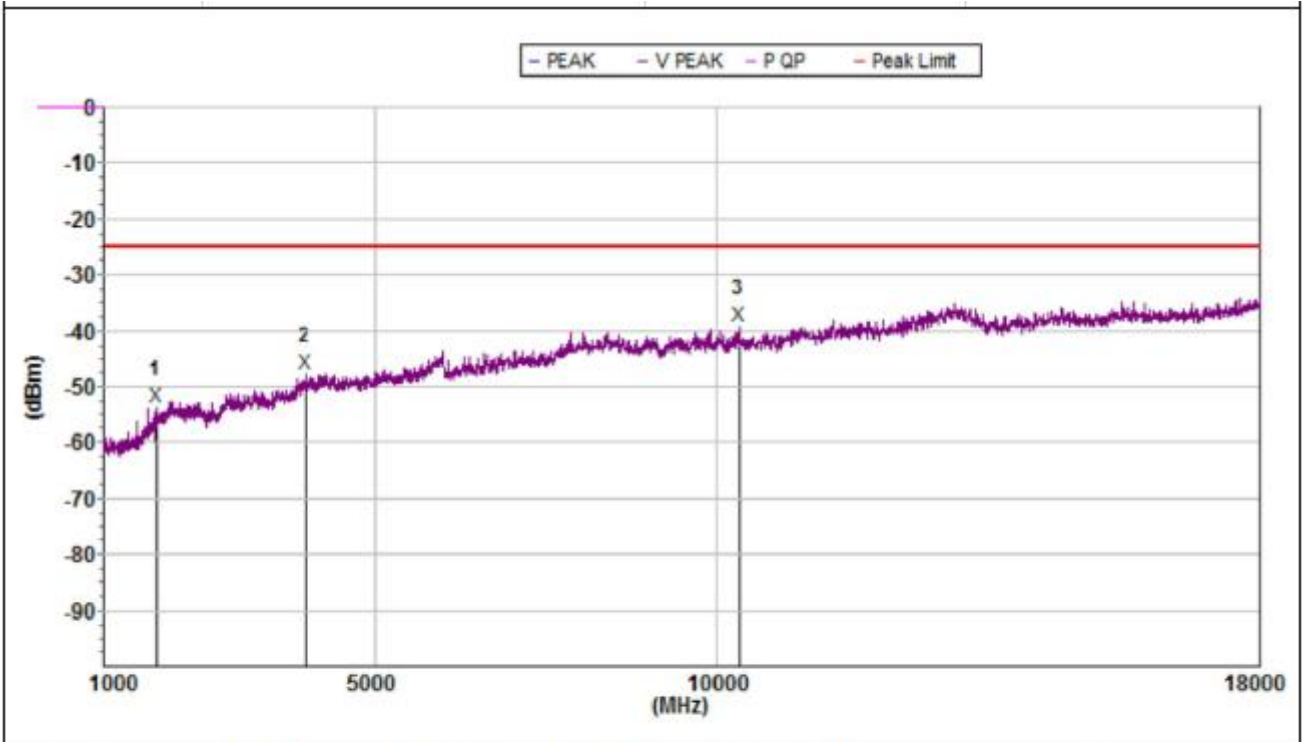

Mk.	Freq (MHz)	Level(dBm)	Limit(dBm)	Margin(dB)	Deg.(deg.)	Hi(cm)	Factor(dB)	Pol.
Peak:								
1	1775.000	-53.7	-25.0	28.7	92.2	150	-10.2	V
2	3977.500	-47.7	-25.0	22.7	0	150	-2.3	V
3	10350.000	-39.0	-25.0	14.0	360	150	7.9	V

NOTE: This document is issued by Shenzhen Morlab Communications Technology Co., Ltd., the test report shall not be reproduced except in full without prior written permission of the company. The test results apply only to the particular sample(s) tested and to the specific tests carried out which is available on request for validation and information confirmed at our website.



Test Mode	LTE Band 41_Traffic Mode_Mid CH_Main antenna
Test Bandwidth	20MHz

Horizontal

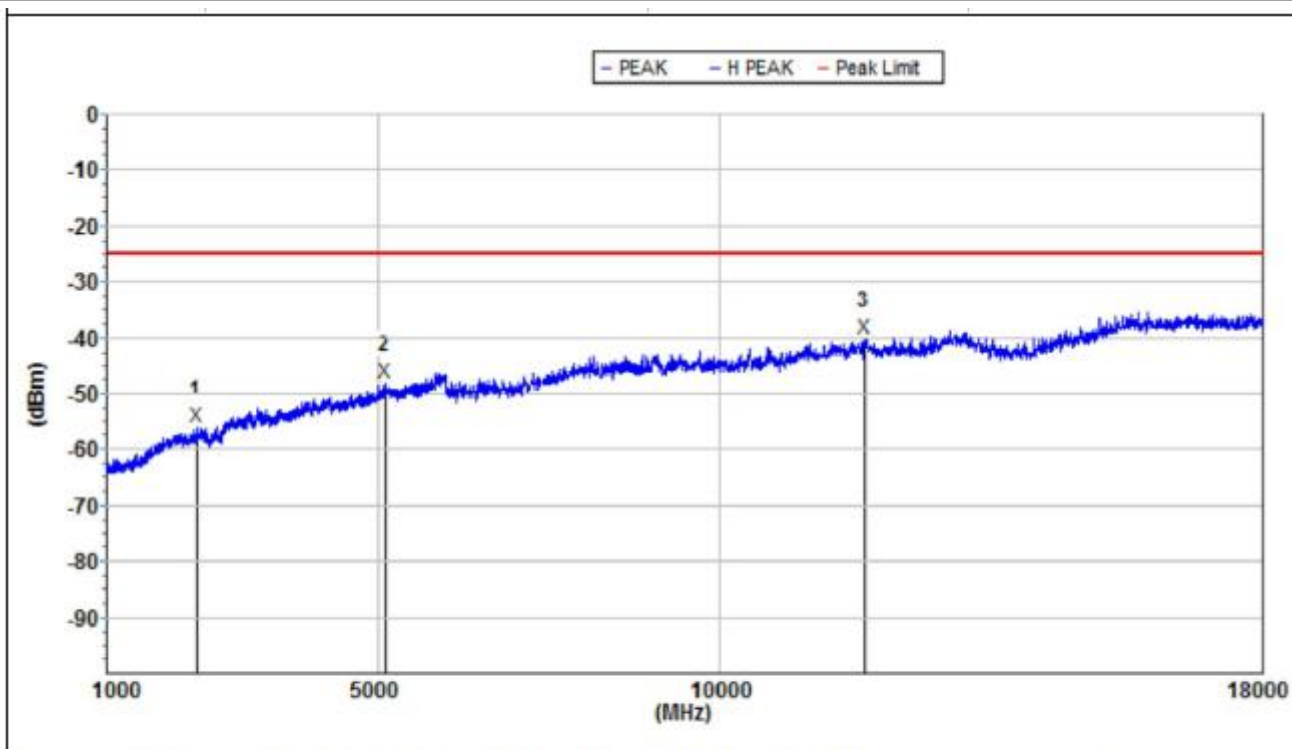

Mk.	Freq.(MHz)	Level(dBm)	Limit(dBm)	Margin(dB)	Deg.(deg.)	Hi(cm)	Factor(dB)	Pol.
Peak:								
1	2332.500	-56.0	-25.0	31.0	199.8	150	-11.3	H
2	5100.000	-47.9	-25.0	22.9	94	150	-1.5	H
3	12156.000	-40.0	-25.0	15.0	0	150	8.1	H

NOTE: This document is issued by Shenzhen Morlab Communications Technology Co., Ltd., the test report shall not be reproduced except in full without prior written permission of the company. The test results apply only to the particular sample(s) tested and to the specific tests carried out which is available on request for validation and information confirmed at our website.



Test Mode	LTE Band 41_Traffic Mode_Mid CH_Main antenna
Test Bandwidth	20MHz

Vertical

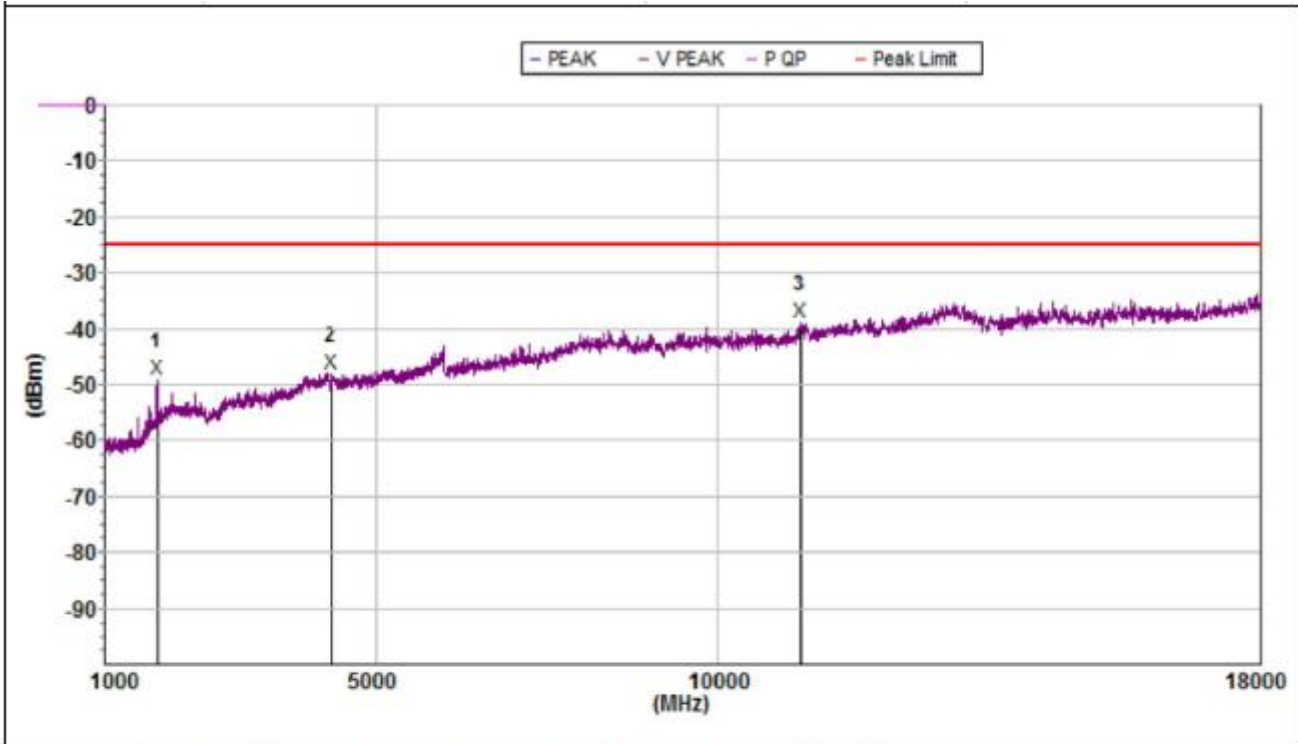

Mk	Freq.(MHz)	Level(dBm)	Limit(dBm)	Margin(dB)	De (+)	Hi(cm)	Factor(dB)	Pol.
Peak:								
1	1772.500	-49.0	-25.0	24.0	81.6	150	-10.2	V
2	4345.000	-47.9	-25.0	22.9	208.2	150	-1.9	V
3	11232.000	-38.8	-25.0	13.8	0.5	150	8.7	V

NOTE: This document is issued by Shenzhen Morlab Communications Technology Co., Ltd., the test report shall not be reproduced except in full without prior written permission of the company. The test results apply only to the particular sample(s) tested and to the specific tests carried out which is available on request for validation and information confirmed at our website.



Test Mode	LTE Band 41_Traffic Mode_Low CH_Main antenna
Test Bandwidth	20MHz

Horizontal

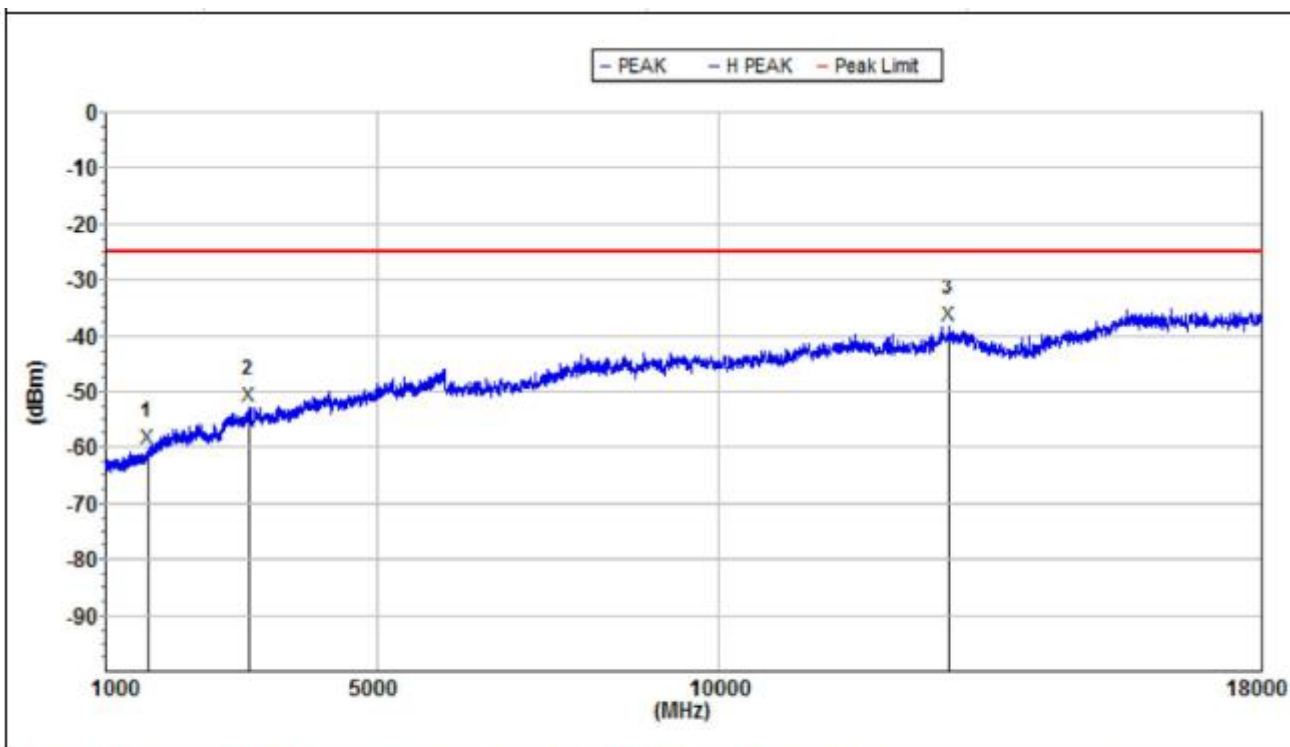

Mk.	Freq.(MHz)	Level(dBm)	Limit(dBm)	Margin(dB)	Deg.(deg.)	Hi.(cm)	Factor(dB)	Pol.
Peak:								
1	1620.000	-60.3	-25.0	35.3	15.8	150	-14.7	H
2	3120.000	-52.6	-25.0	27.6	208.2	150	-8.1	H
3	13416.000	-38.0	-25.0	13.0	360	150	9.6	H

NOTE: This document is issued by Shenzhen Morlab Communications Technology Co., Ltd., the test report shall not be reproduced except in full without prior written permission of the company. The test results apply only to the particular sample(s) tested and to the specific tests carried out which is available on request for validation and information confirmed at our website.



Test Mode	LTE Band 41_Traffic Mode_Low CH_Main antenna
Test Bandwidth	20MHz

Vertical

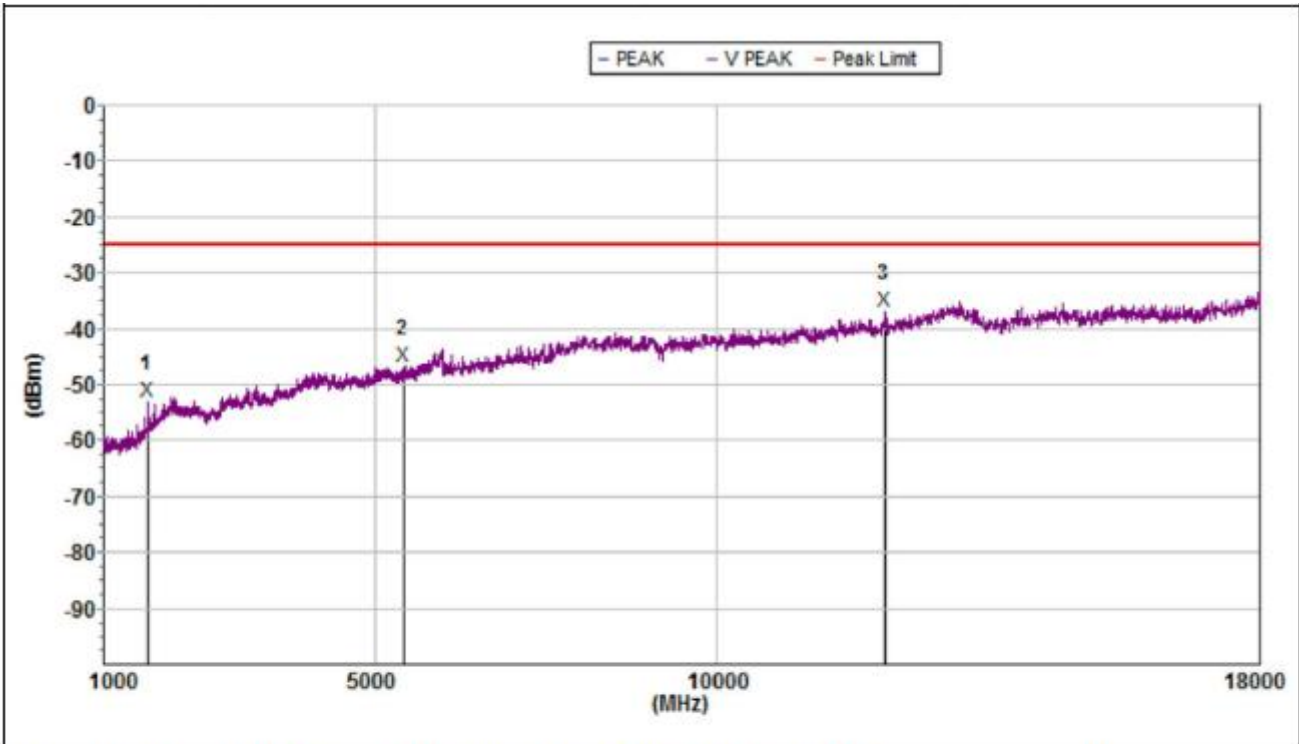

Mk.	Freq.(MHz)	Level(dBm)	Limit(dBm)	Margin(dB)	Deg.(deg.)	Hi(cm)	Factor(dB)	Pol.
Peak:								
1	1665.000	-53.0	-25.0	28.0	170.2	150	-11.8	V
2	5402.500	-46.6	-25.0	21.6	360	150	-0.3	V
3	12486.000	-36.7	-25.0	11.7	0.8	150	10.0	V

NOTE: This document is issued by Shenzhen Morlab Communications Technology Co., Ltd., the test report shall not be reproduced except in full without prior written permission of the company. The test results apply only to the particular sample(s) tested and to the specific tests carried out which is available on request for validation and information confirmed at our website.



Test Mode	LTE Band 66_Traffic Mode_High CH_Main antenna
Test Bandwidth	20MHz

Horizontal

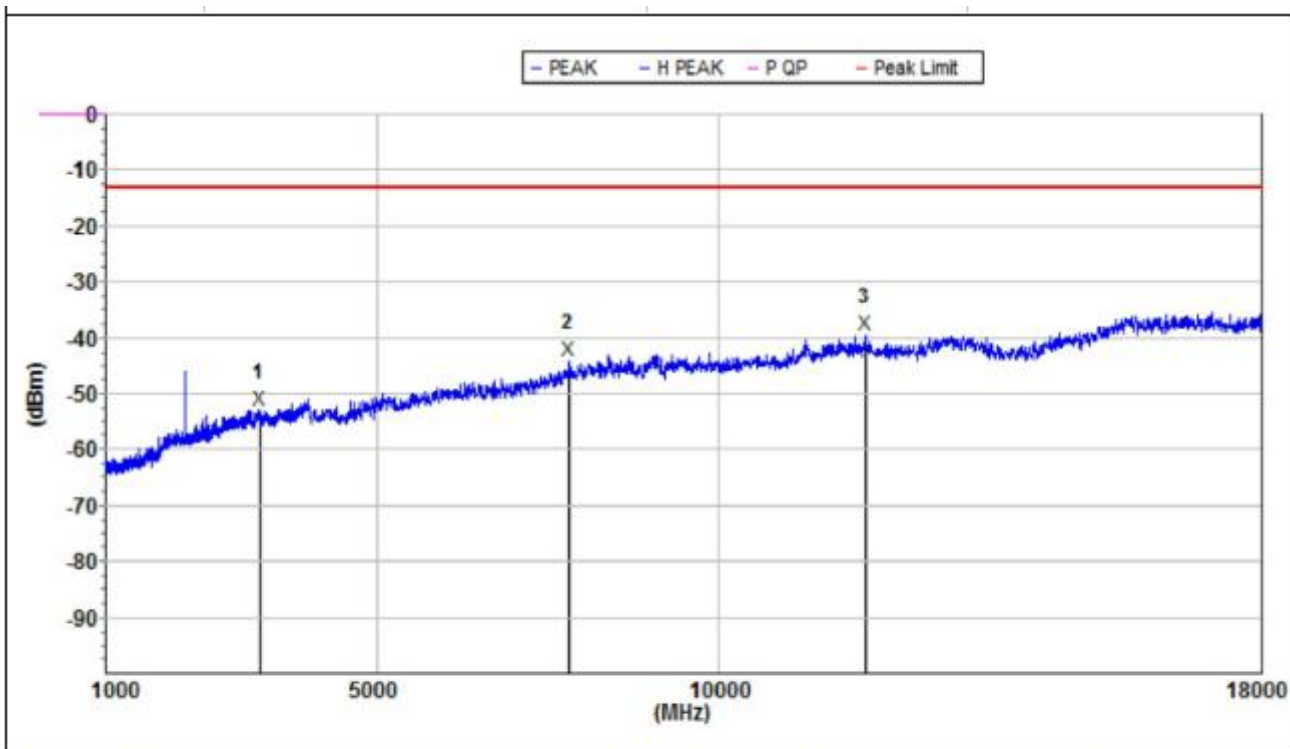

Mk	Freq (MHz)	Level(dBm)	Limit(dBm)	Margin(dB)	Deg (deg.)	Hi (cm)	Factor(dB)	Pol.
Peak:								
1	3263.500	-52.8	-13.0	39.8	205.3	150	-8.0	H
2	7822.000	-44.1	-13.0	31.1	360	150	3.6	H
3	12169.000	-39.4	-13.0	26.4	360	150	8.1	H

NOTE: This document is issued by Shenzhen Morlab Communications Technology Co., Ltd., the test report shall not be reproduced except in full without prior written permission of the company. The test results apply only to the particular sample(s) tested and to the specific tests carried out which is available on request for validation and information confirmed at our website.



Test Mode	LTE Band 66_Traffic Mode_High CH_Main antenna
Test Bandwidth	20MHz

Vertical

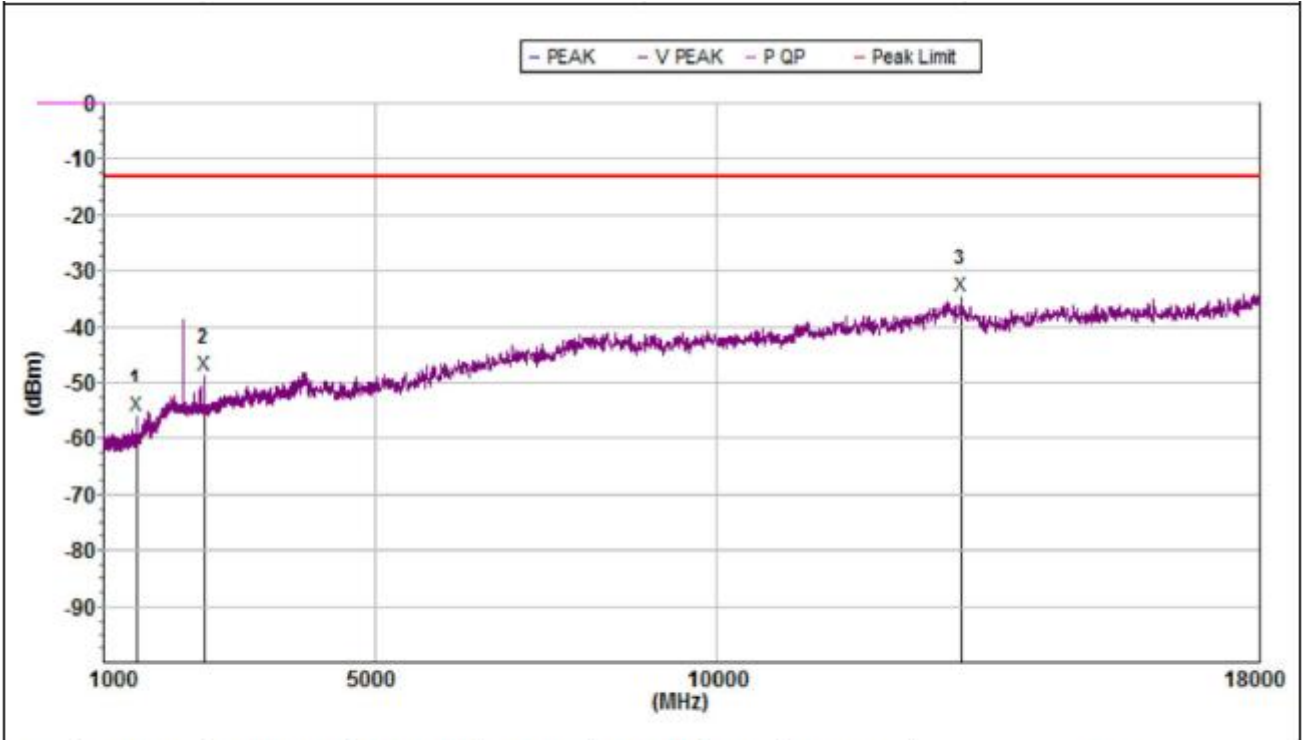

Mk	Freq.(MHz)	Level(dBm)	Limit(dBm)	Margin(dB)	Deg.(deg.)	Hi.(cm)	Factor(dB)	Pol.
Peak:								
1	1501.000	-55.8	-13.0	42.8	180.5	150	-14.2	V
2	2500.000	-48.7	-13.0	35.7	180.5	150	-9.0	V
3	13604.000	-34.6	-13.0	21.6	0	150	13.0	V

NOTE: This document is issued by Shenzhen Morlab Communications Technology Co., Ltd., the test report shall not be reproduced except in full without prior written permission of the company. The test results apply only to the particular sample(s) tested and to the specific tests carried out which is available on request for validation and information confirmed at our website.



Test Mode	LTE Band 66_Traffic Mode_Mid CH_Main antenna
Test Bandwidth	20MHz

Horizontal

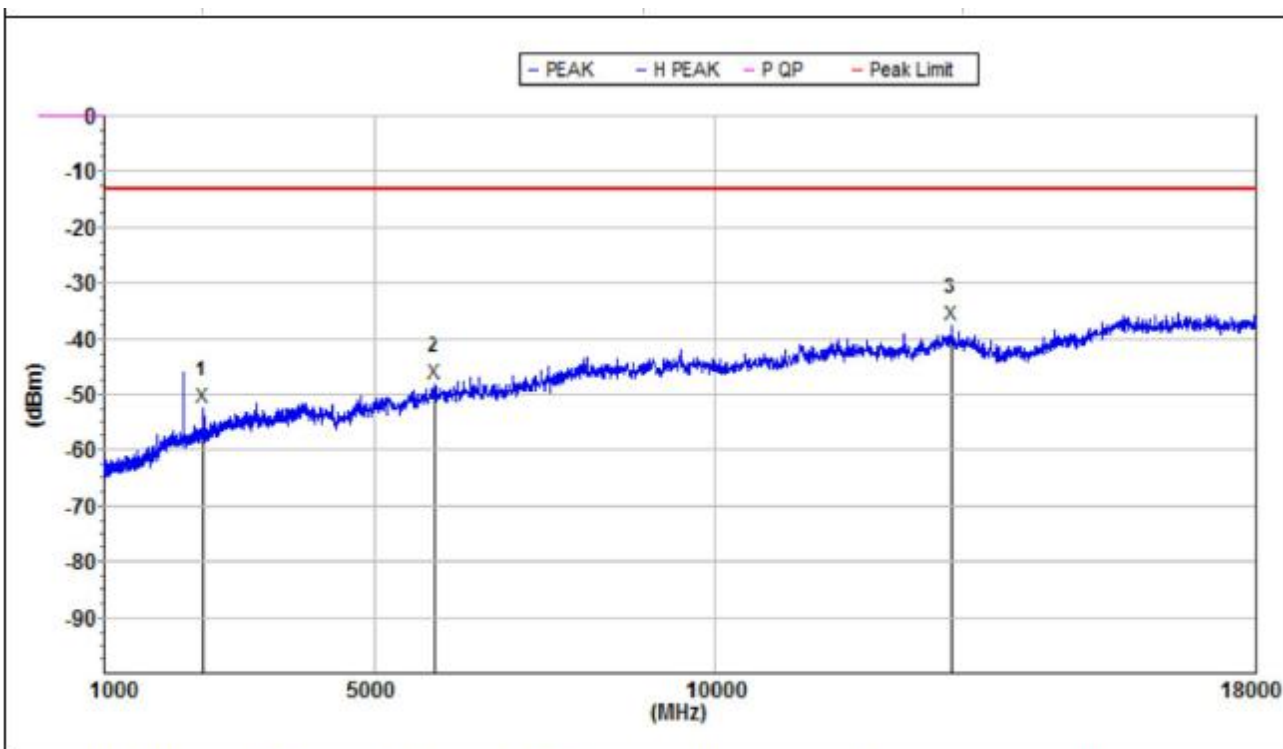

Mk.	Freq. (MHz)	Level(dBm)	Limit(dBm)	Margin(dB)	Deg. (deg.)	Hi. (cm)	Factor(dB)	Pol.
Peak:								
1	2456.500	-52.3	-13.0	39.3	216.7	150	-11.5	H
2	5883.000	-48.0	-13.0	35.0	359.9	150	-0.2	H
3	13506.000	-37.4	-13.0	24.4	359.9	150	10.0	H

NOTE: This document is issued by Shenzhen Morlab Communications Technology Co., Ltd., the test report shall not be reproduced except in full without prior written permission of the company. The test results apply only to the particular sample(s) tested and to the specific tests carried out which is available on request for validation and information confirmed at our website.



Test Mode	LTE Band 66_Traffic Mode_Mid CH_Main antenna
Test Bandwidth	20MHz

Vertical

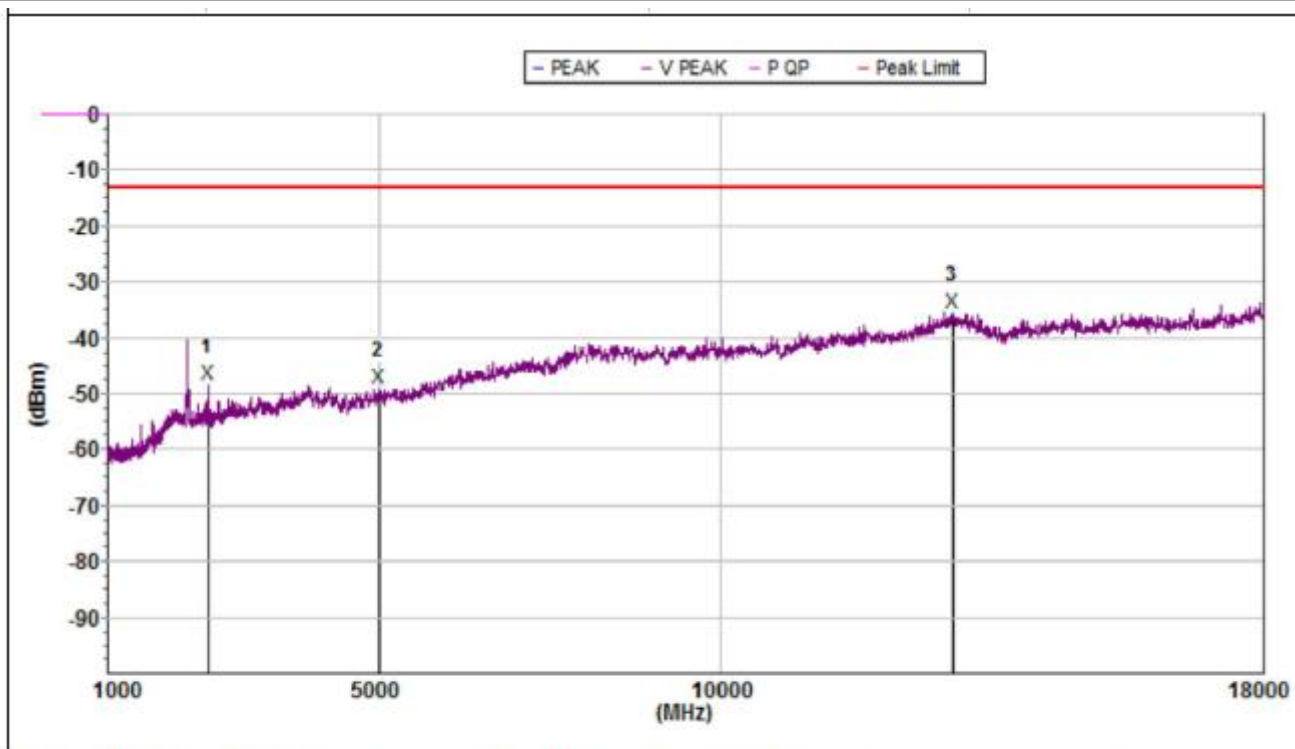

Mk.	Freq.(MHz)	Level(dBm)	Limit(dBm)	Margin(dB)	Deg.(deg.)	Hi.(cm)	Factor(dB)	Pol.
Peak:								
1	2500.000	-48.2	-13.0	35.2	190.1	150	-9.0	V
2	5008.000	-49.0	-13.0	36.0	359.9	150	-0.9	V
3	13422.000	-35.4	-13.0	22.4	359.9	150	13.2	V

NOTE: This document is issued by Shenzhen Morlab Communications Technology Co., Ltd., the test report shall not be reproduced except in full without prior written permission of the company. The test results apply only to the particular sample(s) tested and to the specific tests carried out which is available on request for validation and information confirmed at our website.



Test Mode	LTE Band 66_Traffic Mode_Low CH_Main antenna
Test Bandwidth	20MHz

Horizontal

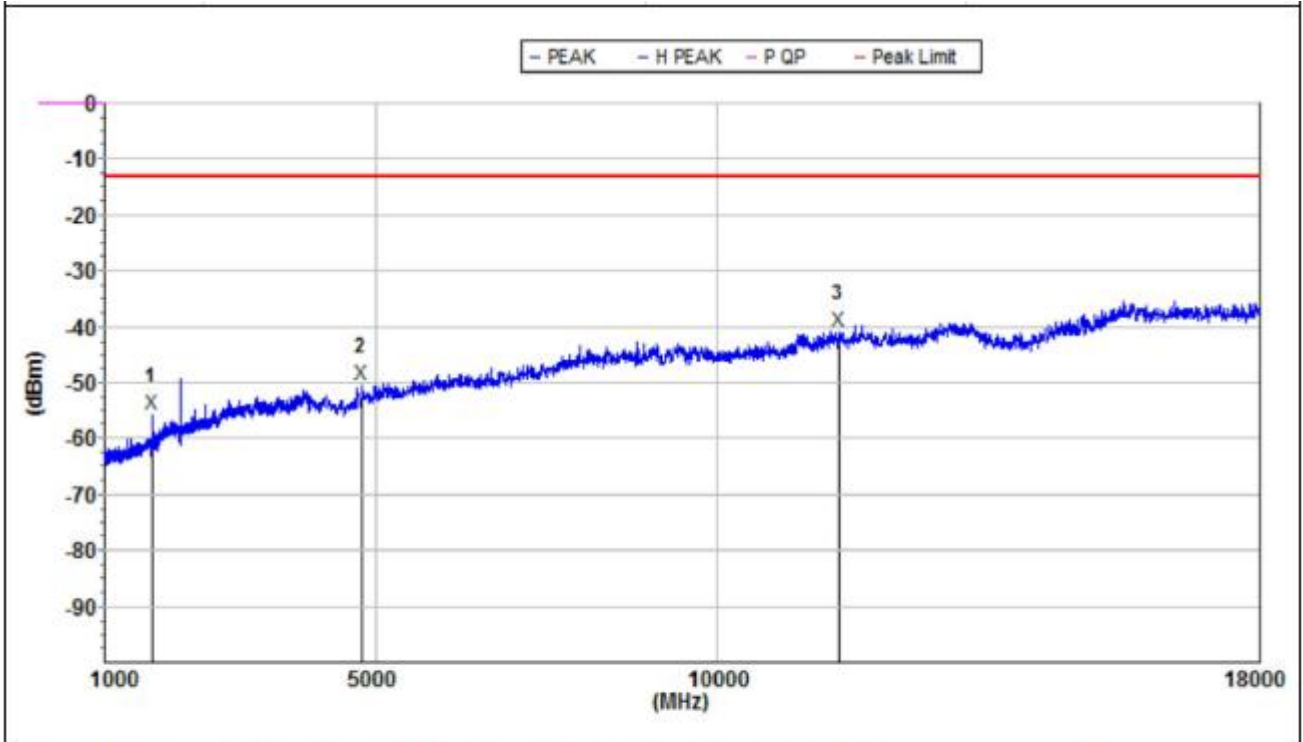

Mk.	Freq.(MHz)	Level(dBm)	Limit(dBm)	Margin(dB)	Deg.(deg.)	Hi(cm)	Factor(dB)	Pol.
Peak:								
1	1715.500	-55.7	-13.0	42.7	276.8	150	-13.8	H
2	4791.000	-50.3	-13.0	37.3	0	150	-3.2	H
3	11812.000	-40.7	-13.0	27.7	0	150	7.7	H

NOTE: This document is issued by Shenzhen Morlab Communications Technology Co., Ltd., the test report shall not be reproduced except in full without prior written permission of the company. The test results apply only to the particular sample(s) tested and to the specific tests carried out which is available on request for validation and information confirmed at our website.



Test Mode	LTE Band 66_Traffic Mode_Low CH_Main antenna
Test Bandwidth	20MHz

Vertical

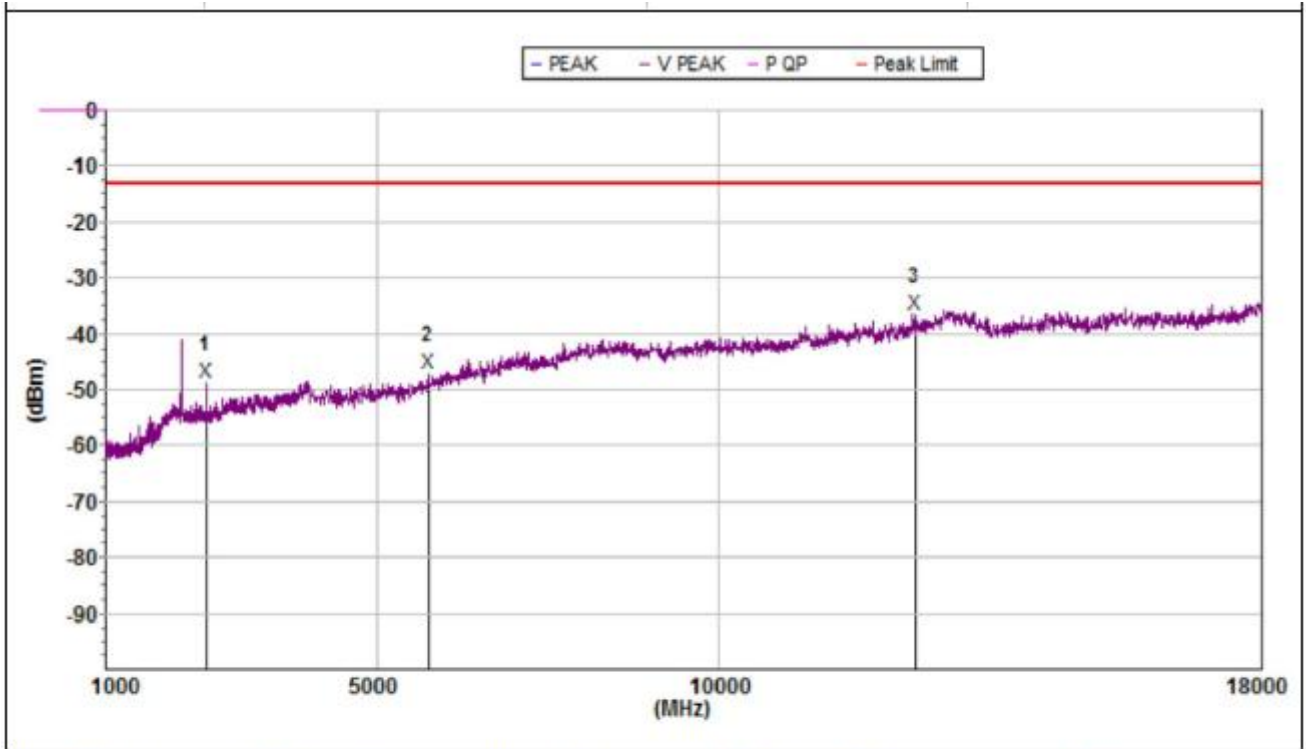

Mk.	Freq.(MHz)	Level(dBm)	Limit(dBm)	Margin(dB)	Deg.(deg.)	Hi(cm)	Factor(dB)	Pol.
Peak:								
1	2500.000	-48.7	-13.0	35.7	186.8	150	-9.0	V
2	5750.000	-46.9	-13.0	33.9	359.8	150	0.9	V
3	12904.000	-36.4	-13.0	23.4	359.8	150	11.0	V

NOTE: This document is issued by Shenzhen Morlab Communications Technology Co., Ltd., the test report shall not be reproduced except in full without prior written permission of the company. The test results apply only to the particular sample(s) tested and to the specific tests carried out which is available on request for validation and information confirmed at our website.



4. TEST SETUP PHOTOGRAPHS

Please refer to the Appendix F.

5. EXTERNAL AND INTERNAL PHOTOS OF THE EUT

External Please refer to the Appendix G.

Internal Please refer to the Appendix H.

※※※※END OF THE REPORT※※※※

NOTE: This document is issued by Shenzhen Morlab Communications Technology Co., Ltd., the test report shall not be reproduced except in full without prior written permission of the company. The test results apply only to the particular sample(s) tested and to the specific tests carried out which is available on request for validation and information confirmed at our website.

