



FCC TEST REPORT

(15.247)

REPORT NO.: RF140804C28

MODEL NO.: DWL-6610AP

FCC ID: KA2WL6610APA1

RECEIVED: Jul. 22, 2014

TESTED: Aug. 07 ~ Oct. 15, 2014

Jan. 23 ~ Jan. 29, 2015

Apr. 17 ~ Apr. 18, 2015

ISSUED: Apr. 23, 2015

APPLICANT: D-Link Corporation

ADDRESS: No. 289, Xinhua 3rd Rd., Neihu District, Taipei City
11494, Taiwan, R.O.C.

ISSUED BY: Bureau Veritas Consumer Products Services
(H.K.) Ltd., Taoyuan Branch

LAB ADDRESS: No. 47-2, 14th Ling, Chia Pau Vil., Lin Kou Dist.,
New Taipei City, Taiwan, R.O.C.

TEST LOCATION: No. 19, Hwa Ya 2nd Rd, Wen Hwa Tsuen, Kwei
Shan Hsiang, Taoyuan Hsien 333, Taiwan, R.O.C.

This report should not be used by the client to claim product certification, approval, or endorsement by TAF or any government agencies.



This report is for your exclusive use. Any copying or replication of this report to or for any other person or entity, or use of our name or trademark, is permitted only with our prior written permission. This report sets forth our findings solely with respect to the test samples identified herein. The results set forth in this report are not indicative or representative of the quality or characteristics of the lot from which a test sample was taken or any similar or identical product unless specifically and expressly noted. Our report includes all of the tests requested by you and the results thereof based upon the information that you provided to us. You have 60 days from date of issuance of this report to notify us of any material error or omission caused by our negligence, provided, however, that such notice shall be in writing and shall specifically address the issue you wish to raise. A failure to raise such issue within the prescribed time shall constitute your unqualified acceptance of the completeness of this report, the tests conducted and the correctness of the report contents. Unless specific mention, the uncertainty of measurement has been explicitly taken into account to declare the compliance or non-compliance to the specification.



A D T

TABLE OF CONTENTS

RELEASE CONTROL RECORD.....	4
1. CERTIFICATION	5
2. SUMMARY OF TEST RESULTS	6
2.1 MEASUREMENT UNCERTAINTY.....	6
3. GENERAL INFORMATION.....	7
3.1 GENERAL DESCRIPTION OF EUT	7
3.2 DESCRIPTION OF TEST MODES	8
3.2.1 TEST MODE APPLICABILITY AND TESTED CHANNEL DETAIL.....	9
3.3 DUTY CYCLE OF TEST SIGNAL.....	12
3.4 DESCRIPTION OF SUPPORT UNITS	13
3.4.1 CONFIGURATION OF SYSTEM UNDER TEST	13
3.5 GENERAL DESCRIPTION OF APPLIED STANDARDS	14
4. TEST TYPES AND RESULTS	15
4.1 RADIATED EMISSION AND BANDEDGE MEASUREMENT.....	15
4.1.1 LIMITS OF RADIATED EMISSION AND BANDEDGE MEASUREMENT	15
4.1.2 TEST INSTRUMENTS.....	16
4.1.3 TEST PROCEDURES	19
4.1.4 DEVIATION FROM TEST STANDARD	19
4.1.5 TEST SETUP.....	20
4.1.6 EUT OPERATING CONDITIONS	21
4.1.7 TEST RESULTS	22
4.2 CONDUCTED EMISSION MEASUREMENT	37
4.2.1 LIMITS OF CONDUCTED EMISSION MEASUREMENT.....	37
4.2.2 TEST INSTRUMENTS.....	37
4.2.3 TEST PROCEDURES	39
4.2.4 DEVIATION FROM TEST STANDARD	39
4.2.5 TEST SETUP.....	39
4.2.6 EUT OPERATING CONDITIONS	39
4.2.7 TEST RESULTS	40
4.3 6dB BANDWIDTH MEASUREMENT.....	46
4.3.1 LIMITS OF 6dB BANDWIDTH MEASUREMENT	46
4.3.2 TEST SETUP.....	46
4.3.3 TEST INSTRUMENTS.....	46
4.3.4 TEST PROCEDURE.....	46
4.3.5 DEVIATION FROM TEST STANDARD	46
4.3.6 EUT OPERATING CONDITIONS	46
4.3.7 TEST RESULTS	47
4.4 CONDUCTED OUTPUT POWER	49
4.4.1 LIMITS OF CONDUCTED OUTPUT POWER MEASUREMENT	49
4.4.2 TEST SETUP.....	49
4.4.3 TEST INSTRUMENTS.....	49
4.4.4 TEST PROCEDURES	49
4.4.5 DEVIATION FROM TEST STANDARD	50
4.4.6 EUT OPERATING CONDITIONS	50
4.4.7 TEST RESULTS	51
4.5 POWER SPECTRAL DENSITY MEASUREMENT.....	52
4.5.1 LIMITS OF POWER SPECTRAL DENSITY MEASUREMENT	52
4.5.2 TEST SETUP.....	52
4.5.3 TEST INSTRUMENTS.....	52
4.5.4 TEST PROCEDURE.....	52



A D T

4.5.5	DEVIATION FROM TEST STANDARD	52
4.5.6	EUT OPERATING CONDITION	52
4.5.7	TEST RESULTS	53
4.6	CONDUCTED OUT OF BAND EMISSION MEASUREMENT.....	55
4.6.1	LIMITS OF CONDUCTED OUT OF BAND EMISSION MEASUREMENT	55
4.6.2	TEST SETUP.....	55
4.6.3	TEST INSTRUMENTS.....	55
4.6.4	TEST PROCEDURE.....	56
4.6.5	DEVIATION FROM TEST STANDARD	56
4.6.6	EUT OPERATING CONDITION	56
4.6.7	TEST RESULTS	56
5.	PHOTOGRAPHS OF THE TEST CONFIGURATION.....	64
6.	INFORMATION ON THE TESTING LABORATORIES	65
7.	APPENDIX A – MODIFICATIONS RECORDERS FOR ENGINEERING CHANGES TO THE EUT BY THE LAB.....	66



RELEASE CONTROL RECORD

ISSUE NO.	REASON FOR CHANGE	DATE ISSUED
RF140804C28	Original release.	Apr. 23, 2015



1. CERTIFICATION

PRODUCT: Unified AC Concurrent Dual-band PoE Access Point

MODEL NO.: DWL-6610AP

BRAND: D-Link

APPLICANT: D-Link Corporation

TESTED: Aug. 07 ~ Oct. 15, 2014

Jan. 23 ~ Jan. 29, 2015

Apr. 17 ~ Apr. 18, 2015

TEST SAMPLE: ENGINEERING SAMPLE

STANDARDS: **FCC Part 15, Subpart C (Section 15.247)**

ANSI C63.10:2009

The above equipment (model: DWL-6610AP) has been tested by **Bureau Veritas Consumer Products Services (H.K.) Ltd., Taoyuan Branch**, and found compliance with the requirement of the above standards. The test record, data evaluation & Equipment Under Test (EUT) configurations represented herein are true and accurate accounts of the measurements of the sample's EMC characteristics under the conditions specified in this report.

PREPARED BY :  , **DATE :** Apr. 23, 2015
Pettie Chen / Senior Specialist

APPROVED BY :  , **DATE :** Apr. 23, 2015
Ken Liu / Senior Manager

2. SUMMARY OF TEST RESULTS

The EUT has been tested according to the following specifications:

APPLIED STANDARD: FCC PART 15, SUBPART C (SECTION 15.247)			
STANDARD SECTION	TEST TYPE	RESULT	REMARK
15.207	AC Power Conducted Emission	PASS	Meet the requirement of limit. Minimum passing margin is -1.44dB at 3.18591MHz.
15.205 & 209	Radiated Emissions	PASS	Meet the requirement of limit. Minimum passing margin is -1.0dB at 2390.00, 2483.50MHz.
15.247(d)	Band Edge Measurement	PASS	Meet the requirement of limit. Minimum passing margin is -1.0dB at 2483.5MHz.
15.247(d)	Antenna Port Emission	PASS	Meet the requirement of limit.
15.247(a)(2)	6dB bandwidth	PASS	Meet the requirement of limit.
15.247(b)	Conducted power	PASS	Meet the requirement of limit.
15.247(e)	Power Spectral Density	PASS	Meet the requirement of limit.
15.203	Antenna Requirement	PASS	Antenna connector is IPEX not a standard connector. (The device is professionally installed).

2.1 MEASUREMENT UNCERTAINTY

Where relevant, the following measurement uncertainty levels have been estimated for tests performed on the EUT as specified in CISPR 16-4-2:

MEASUREMENT	FREQUENCY	UNCERTAINTY
Conducted emissions	150kHz~30MHz	2.44 dB
Radiated emissions	30MHz ~ 200MHz	3.63 dB
	200MHz ~1000MHz	3.64 dB
	1GHz ~ 18GHz	2.29 dB
	18GHz ~ 40GHz	2.29 dB

This uncertainty represents an expanded uncertainty expressed at approximately the 95% confidence level using a coverage factor of $k = 2$.



3. GENERAL INFORMATION

3.1 GENERAL DESCRIPTION OF EUT

EUT	Unified AC Concurrent Dual-band PoE Access Point
MODEL NO.	DWL-6610AP
POWER SUPPLY	12Vdc from adapter 48Vdc from PoE
MODULATION TYPE	CCK, DQPSK, DBPSK for DSSS 64QAM, 16QAM, QPSK, BPSK for OFDM
MODULATION TECHNOLOGY	DSSS, OFDM
TRANSFER RATE	802.11b: 11.0/ 5.5/ 2.0/ 1.0Mbps 802.11g: 54.0/ 48.0/ 36.0/ 24.0/ 18.0/ 12.0/ 9.0/ 6.0Mbps 802.11n: up to 300.0Mbps
OPERATING FREQUENCY	2412 ~ 2462MHz
NUMBER OF CHANNEL	11 for 802.11b, 802.11g, 802.11n (20MHz) 7 for 802.11n (40MHz)
OUTPUT POWER	490.471mW
ANTENNA TYPE	Ant. 1: PIFA antenna with 5.9dBi gain Ant. 2: PIFA antenna with 5.8dBi gain
ANTENNA CONNECTOR	IPEX
POWER CORD	Refer to NOTE
DATA CABLE	NA
I/O PORTS	Refer to user's manual
ACCESSORY DEVICES	Adapter

NOTE:

1. The EUT incorporates a MIMO function. Physically, the EUT provides two completed transmitters and two receivers.

MODULATION MODE	TX FUNCTION
802.11b	1TX
802.11g	2TX
802.11n (20MHz)	2TX
802.11n (40MHz)	2TX

2. The EUT use following adapters and PoE.

Adapter 1	
Brand:	D-Link
Model:	WA-24K12R
Input:	100-240Vac~50-60Hz, 0.8A Max
Output:	12Vdc, 2A
Power Cord:	1.2m cable without core

Adapter 2	
Brand:	D-Link
Model:	WA-24Q12R
Input:	100-240Vac~50-60Hz, 0.7A Max
Output:	12Vdc, 2A
Power Cord:	1.2m cable without core

PoE (Support unit only)	
Brand:	EnGenius
Model:	NPE-7530G
Rating:	48Vdc

Adapter of PoE (Support unit only)	
Brand:	Powertron Electronics Corp.
Model:	PA1040-480IB080
Input:	100-240V~50-60Hz, 1.5A
Output:	48Vdc, 0.5A 24W Max
Power Cord:	1.6m non-shielded cable with one core

3. The above EUT information is declared by manufacturer and for more detailed features description, please refer to the manufacturer's specifications or user's manual.

3.2 DESCRIPTION OF TEST MODES

11 channels are provided for 802.11b, 802.11g and 802.11n (20MHz):

CHANNEL	FREQUENCY	CHANNEL	FREQUENCY
1	2412MHz	7	2442MHz
2	2417MHz	8	2447MHz
3	2422MHz	9	2452MHz
4	2427MHz	10	2457MHz
5	2432MHz	11	2462MHz
6	2437MHz		

7 channels are provided for 802.11n (40MHz):

CHANNEL	FREQUENCY	CHANNEL	FREQUENCY
3	2422MHz	7	2442MHz
4	2427MHz	8	2447MHz
5	2432MHz	9	2452MHz
6	2437MHz		



3.2.1 TEST MODE APPLICABILITY AND TESTED CHANNEL DETAIL

EUT CONFIGURE MODE	APPLICABLE TO				DESCRIPTION
	RE≥1G	RE<1G	PLC	APCM	
A	√	√	√	√	Power from adapter 1
B	-	√	√	-	Power from adapter 2
C	-	√	√	-	Power from PoE

Where **RE≥1G**: Radiated Emission above 1GHz **RE<1G**: Radiated Emission below 1GHz
PLC: Power Line Conducted Emission **APCM**: Antenna Port Conducted Measurement

NOTE:

1. The EUT had been pre-tested on the positioned of each 3 axis. The worst case was found when positioned on **Z-plane**.
2. "-" means no effect.

RADIATED EMISSION TEST (ABOVE 1GHz):

- Pre-Scan has been conducted to determine the worst-case mode from all possible combinations between available modulations, data rates and antenna ports (if EUT with antenna diversity architecture).
- Following channel(s) was (were) selected for the final test as listed below.

EUT CONFIGURE MODE	MODE	AVAILABLE CHANNEL	TESTED CHANNEL	MODULATION TECHNOLOGY	MODULATION TYPE	DATA RATE (Mbps)
A	802.11b	1 to 11	1, 6, 11	DSSS	DBPSK	1.0
A	802.11g	1 to 11	1, 6, 11	OFDM	BPSK	6.0
A	802.11n (20MHz)	1 to 11	1, 6, 11	OFDM	BPSK	7.2
A	802.11n (40MHz)	3 to 9	3, 6, 9	OFDM	BPSK	15.0

RADIATED EMISSION TEST (BELOW 1GHz):

- Pre-Scan has been conducted to determine the worst-case mode from all possible combinations between available modulations, data rates and antenna ports (if EUT with antenna diversity architecture).
- Following channel(s) was (were) selected for the final test as listed below.

EUT CONFIGURE MODE	MODE	AVAILABLE CHANNEL	TESTED CHANNEL	MODULATION TECHNOLOGY	MODULATION TYPE	DATA RATE (Mbps)
A, B, C	802.11g	1 to 11	6	OFDM	BPSK	6.0



POWER LINE CONDUCTED EMISSION TEST:

- Pre-Scan has been conducted to determine the worst-case mode from all possible combinations between available modulations, data rates and antenna ports (if EUT with antenna diversity architecture).
- Following channel(s) was (were) selected for the final test as listed below.

EUT CONFIGURE MODE	MODE	AVAILABLE CHANNEL	TESTED CHANNEL	MODULATION TECHNOLOGY	MODULATION TYPE	DATA RATE (Mbps)
A, B, C	802.11g	1 to 11	6	OFDM	BPSK	6.0

BANDEDGE MEASUREMENT:

- Pre-Scan has been conducted to determine the worst-case mode from all possible combinations between available modulations, data rates and antenna ports (if EUT with antenna diversity architecture).
- Following channel(s) was (were) selected for the final test as listed below.

EUT CONFIGURE MODE	MODE	AVAILABLE CHANNEL	TESTED CHANNEL	MODULATION TECHNOLOGY	MODULATION TYPE	DATA RATE (Mbps)
A	802.11b	1 to 11	1, 11	DSSS	DBPSK	1.0
A	802.11g	1 to 11	1, 11	OFDM	BPSK	6.0
A	802.11n (20MHz)	1 to 11	1, 11	OFDM	BPSK	7.2
A	802.11n (40MHz)	3 to 9	3, 9	OFDM	BPSK	15.0

ANTENNA PORT CONDUCTED MEASUREMENT:

- This item includes all test value of each mode, but only includes spectrum plot of worst value of each mode.
- Pre-Scan has been conducted to determine the worst-case mode from all possible combinations between available modulations, data rates and antenna ports (if EUT with antenna diversity architecture).
- Following channel(s) was (were) selected for the final test as listed below.

EUT CONFIGURE MODE	MODE	AVAILABLE CHANNEL	TESTED CHANNEL	MODULATION TECHNOLOGY	MODULATION TYPE	DATA RATE (Mbps)
A	802.11b	1 to 11	1, 6, 11	DSSS	DBPSK	1.0
A	802.11g	1 to 11	1, 6, 11	OFDM	BPSK	6.0
A	802.11n (20MHz)	1 to 11	1, 6, 11	OFDM	BPSK	7.2
A	802.11n (40MHz)	3 to 9	3, 6, 9	OFDM	BPSK	15.0



A D T

TEST CONDITION:

APPLICABLE TO	ENVIRONMENTAL CONDITIONS	INPUT POWER (SYSTEM)	TESTED BY
RE \geq 1G	25deg. C, 65%RH	120Vac, 60Hz	Ted Chang
RE<1G	25deg. C, 65%RH 20deg. C, 70%RH	120Vac, 60Hz 48Vdc	Ted Chang Match Tsui Jones Chang
PLC	25deg. C, 65%RH 24deg. C, 64%RH 18deg. C, 70%RH	120Vac, 60Hz 48Vdc	Ted Chang Match Tsui Nick Hsu
APCM	25deg. C, 60%RH	120Vac, 60Hz	Ted Chang

3.3 DUTY CYCLE OF TEST SIGNAL

Duty cycle of test signal is > 98 %, duty factor is not required.

802.11g: Duty cycle = 2.056/2.096 = 0.981 >98%

802.11n (20MHz): Duty cycle = 1.898/1.937 = 0.98 = 98%

Duty cycle is < 98%, duty factor shall be considered.

802.11b: Duty cycle = 0.017/0.02 = 0.85, Duty factor = $10 * \log(1/0.85) = 0.71$

802.11n (40MHz): Duty cycle = 0.936/0.965 = 0.97, Duty factor = $10 * \log(1/0.97) = 0.13$

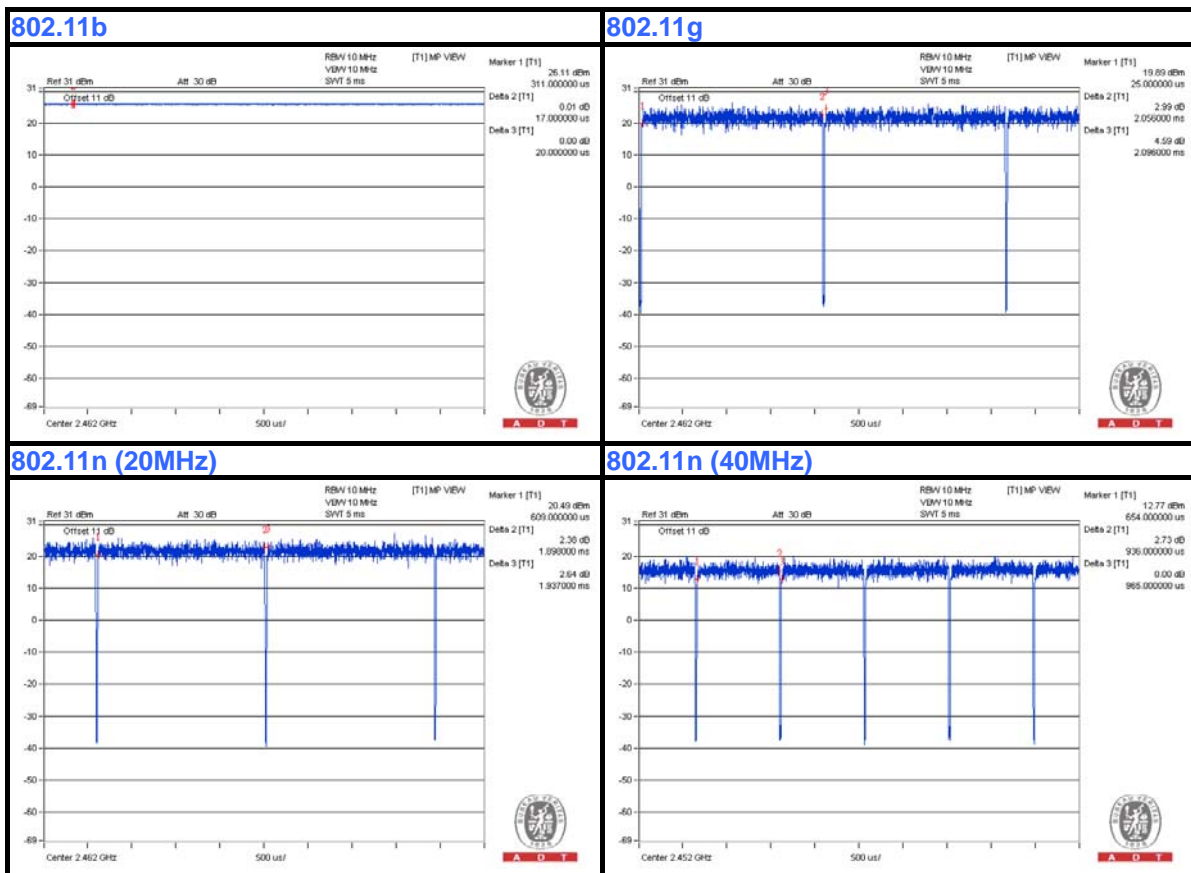

3.4 DESCRIPTION OF SUPPORT UNITS

The EUT has been tested as an independent unit together with other necessary accessories or support units. The following support units or accessories were used to form a representative test configuration during the tests.

NO.	PRODUCT	BRAND	MODEL NO.	SERIAL NO.	FCC ID
1	Notebook	DELL	D531	CN-0XM006-48643 -81U-2973	QDS-BRCM1020

NO.	SIGNAL CABLE DESCRIPTION OF THE ABOVE SUPPORT UNITS
1	10m RJ45 UTP cable

NOTE:

1. All power cords of the above support units are non-shielded (1.8m).
2. Item 1 acted as communication partners to transfer data.

3.4.1 CONFIGURATION OF SYSTEM UNDER TEST

Test Mode A, B

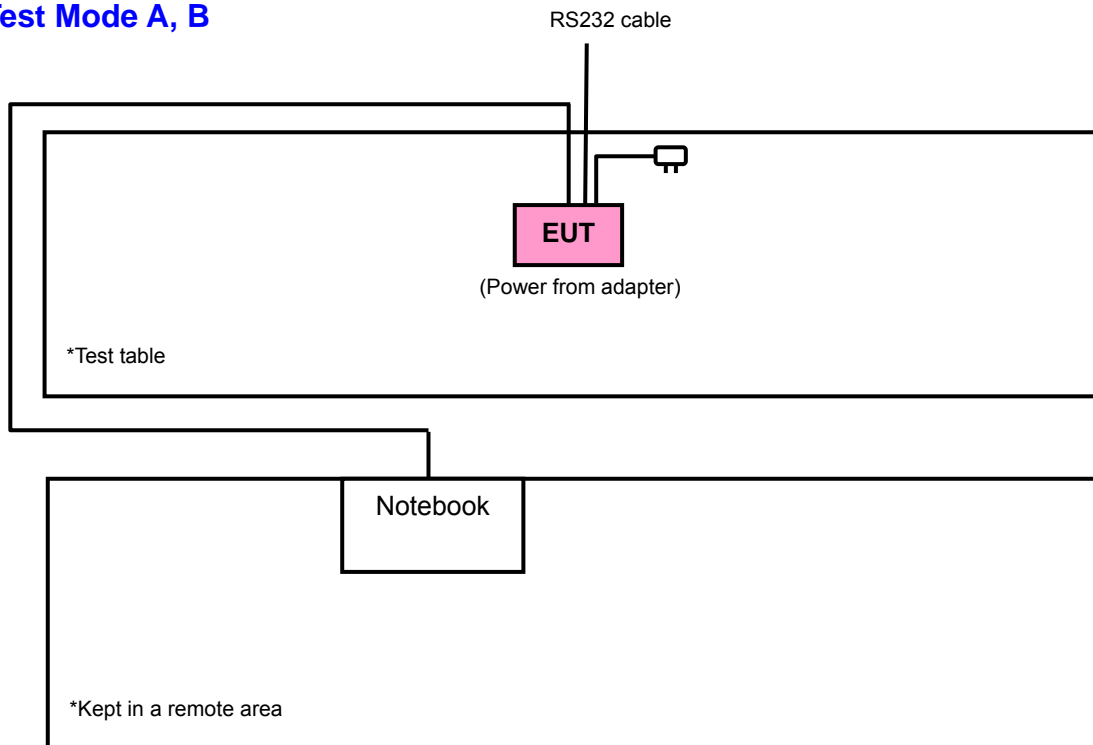

Test Mode C

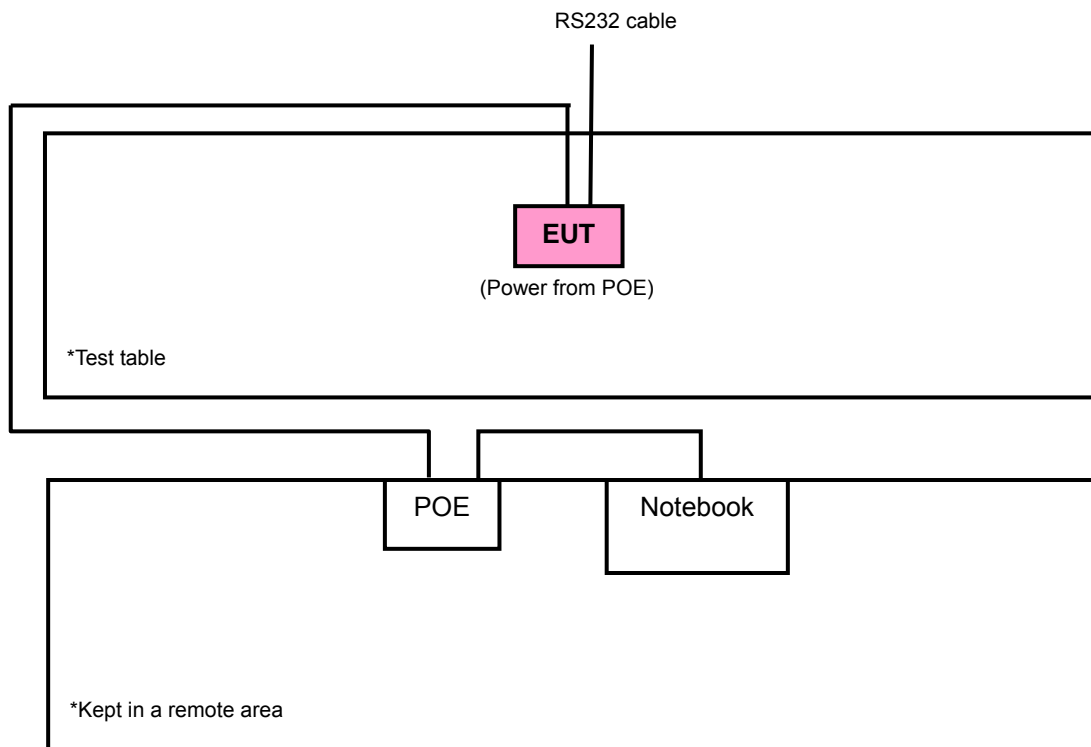

3.5 GENERAL DESCRIPTION OF APPLIED STANDARDS

The EUT is a RF Product. According to the specifications of the manufacturer, it must comply with the requirements of the following standards:

FCC Part 15, Subpart C (15.247)

558074 D01 DTS Meas Guidance v03r02

662911 D01 Multiple Transmitter Output v02r01

ANSI C63.10-2009

All test items have been performed and recorded as per the above standards.

NOTE: The EUT is also considered as a kind of computer peripheral, because the connection to computer is necessary for typical use. It has been verified to comply with the requirements of FCC Part 15, Subpart B, Class B (DoC). The test report has been issued separately.

4. TEST TYPES AND RESULTS

4.1 RADIATED EMISSION AND BANDEDGE MEASUREMENT

4.1.1 LIMITS OF RADIATED EMISSION AND BANDEDGE MEASUREMENT

Radiated emissions which fall in the restricted bands must comply with the radiated emission limits specified as below table. Other emissions shall be at least 30dB below the highest level of the desired power:

FREQUENCIES (MHz)	FIELD STRENGTH (microvolts/meter)	MEASUREMENT DISTANCE (meters)
0.009 ~ 0.490	2400/F(kHz)	300
0.490 ~ 1.705	24000/F(kHz)	30
1.705 ~ 30.0	30	30
30 ~ 88	100	3
88 ~ 216	150	3
216 ~ 960	200	3
Above 960	500	3

NOTE:

1. The lower limit shall apply at the transition frequencies.
2. Emission level (dBuV/m) = 20 log Emission level (uV/m).
3. For frequencies above 1000MHz, the field strength limits are based on average detector, however, the peak field strength of any emission shall not exceed the maximum permitted average limits, specified above by more than 30dB under any condition of modulation.

4.1.2 TEST INSTRUMENTS

Tested Date: Aug. 07 ~ Oct. 15, 2014

DESCRIPTION & MANUFACTURER	MODEL NO.	SERIAL NO.	DATE OF CALIBRATION	DUE DATE OF CALIBRATION
Test Receiver ROHDE & SCHWARZ	ESCS30	100289	Nov. 29, 2013	Nov. 28, 2014
Spectrum Analyzer ROHDE & SCHWARZ	FSP40	100269	Feb. 11, 2014	Feb. 10, 2015
BILOG Antenna SCHWARZBECK	VULB9168	9168-156	Feb. 25, 2014	Feb. 24, 2015
HORN Antenna SCHWARZBECK	BBHA 9120D	9120D-404	Jan. 05, 2014	Jan. 04, 2015
HORN Antenna SCHWARZBECK	BBHA 9170	BBHA9170241	Feb. 17, 2014	Feb. 16, 2015
Preamplifier Agilent	8449B	3008A01911	Aug. 09, 2014	Aug. 08, 2015
Preamplifier Agilent	8447D	2944A10638	Aug. 09, 2014	Aug. 08, 2015
RF signal cable HUBER+SUHNNER	SUCOFLEX 104	248780/4 309222/4 274092/4	Aug. 09, 2014	Aug. 08, 2015
RF signal cable Worken	8D-FB	Cable-CH9-01	Aug. 11, 2014	Aug. 10, 2015
Software BV ADT	ADT_Radiated_ V7.6.15.9.4	NA	NA	NA
Antenna Tower EMCO	2070/2080	512.835.4684	NA	NA
Turn Table EMCO	2087-2.03	NA	NA	NA
Antenna Tower & Turn Table Controller EMCO	2090	NA	NA	NA
High Speed Peak Power Meter	ML2495A	0824011	Jul. 26, 2014	Jul. 25, 2015
Power Sensor	MA2411B	0738171	Jul. 26, 2014	Jul. 25, 2015

- NOTE:**
1. The calibration interval of the above test instruments is 12 months and the calibrations are traceable to NML/ROC and NIST/USA.
 2. The test was performed in HwaYa Chamber 9.
 3. The horn antenna and HP preamplifier (model: 8449B) are used only for the measurement of emission frequency above 1GHz if tested.
 4. The FCC Site Registration No. is 215374.
 5. The IC Site Registration No. is IC 7450F-9.



A D T

Tested Date: Jan. 23 ~ Jan. 29, 2015

DESCRIPTION & MANUFACTURER	MODEL NO.	SERIAL NO.	DATE OF CALIBRATION	DUE DATE OF CALIBRATION
Test Receiver ROHDE & SCHWARZ	ESCS30	100289	Dec. 01, 2014	Nov. 30, 2015
Spectrum Analyzer ROHDE & SCHWARZ	FSP40	100269	Feb. 11, 2014	Feb. 10, 2015
BILOG Antenna SCHWARZBECK	VULB9168	9168-156	Feb. 25, 2014	Feb. 24, 2015
HORN Antenna SCHWARZBECK	BBHA 9120 D	9120D-209	Aug. 25, 2014	Aug. 24, 2015
HORN Antenna SCHWARZBECK	BBHA 9170	BBHA9170241	Feb. 17, 2014	Feb. 16, 2015
Preamplifier Agilent	8449B	3008A01911	Aug. 09, 2014	Aug. 08, 2015
Preamplifier Agilent	8447D	2944A10638	Aug. 09, 2014	Aug. 08, 2015
RF signal cable HUBER+SUHNNER	SUCOFLEX 104	248780/4 309222/4 274092/4	Aug. 09, 2014	Aug. 08, 2015
RF signal cable Worken	8D-FB	Cable-CH9-01	Aug. 11, 2014	Aug. 10, 2015
Software BV ADT	ADT_Radiated_ V7.6.15.9.4	NA	NA	NA
Antenna Tower EMCO	2070/2080	512.835.4684	NA	NA
Turn Table EMCO	2087-2.03	NA	NA	NA
Antenna Tower & Turn Table Controller EMCO	2090	NA	NA	NA
High Speed Peak Power Meter	ML2495A	0824011	Jul. 26, 2014	Jul. 25, 2015
Power Sensor	MA2411B	0738171	Jul. 26, 2014	Jul. 25, 2015

- NOTE:**
1. The calibration interval of the above test instruments is 12 months and the calibrations are traceable to NML/ROC and NIST/USA.
 2. The test was performed in HwaYa Chamber 9.
 3. The horn antenna and HP preamplifier (model: 8449B) are used only for the measurement of emission frequency above 1GHz if tested.
 4. The FCC Site Registration No. is 215374.
 5. The IC Site Registration No. is IC 7450F-9.



A D T

Tested Date: Apr. 18, 2015

DESCRIPTION & MANUFACTURER	MODEL NO.	SERIAL NO.	DATE OF CALIBRATION	DUE DATE OF CALIBRATION
Test Receiver ROHDE & SCHWARZ	ESCS30	100289	Dec. 01, 2014	Nov. 30, 2015
Spectrum Analyzer ROHDE & SCHWARZ	FSP40	100269	Mar. 30, 2015	Mar. 29, 2016
BILOG Antenna SCHWARZBECK	VULB9168	9168-156	Feb. 06, 2015	Feb. 05, 2016
HORN Antenna SCHWARZBECK	BBHA 9120 D	9120D-1169	Feb. 09, 2015	Feb. 08, 2016
HORN Antenna SCHWARZBECK	BBHA 9170	BBHA9170241	Feb. 09, 2015	Feb. 08, 2016
Preamplifier Agilent	8449B	3008A01911	Aug. 09, 2014	Aug. 08, 2015
Preamplifier Agilent	8447D	2944A10638	Aug. 09, 2014	Aug. 08, 2015
RF signal cable HUBER+SUHNER	SUCOFLEX 104	248780/4 309222/4 274092/4	Aug. 09, 2014	Aug. 08, 2015
RF signal cable Worken	8D-FB	Cable-CH9-01	Aug. 11, 2014	Aug. 10, 2015
Software BV ADT	ADT_Radiated_ V7.6.15.9.4	NA	NA	NA
Antenna Tower EMCO	2070/2080	512.835.4684	NA	NA
Turn Table EMCO	2087-2.03	NA	NA	NA
Antenna Tower & Turn Table Controller EMCO	2090	NA	NA	NA
Turn Table BV ADT	TT100	TT93021705	NA	NA
Turn Table Controller BV ADT	SC100	SC93021705	NA	NA

- NOTE:** 1. The calibration interval of the above test instruments is 12 months and the calibrations are traceable to NML/ROC and NIST/USA.
2. The test was performed in HwaYa Chamber 9.
3. The horn antenna and HP preamplifier (model: 8449B) are used only for the measurement of emission frequency above 1GHz if tested.
4. The FCC Site Registration No. is 215374.
5. The IC Site Registration No. is IC 7450F-9.

4.1.3 TEST PROCEDURES

- a. The EUT was placed on the top of a rotating table 0.8 meters (for below 1GHz) / 1.5 meters (for above 1GHz) above the ground at 3 meter chamber room for test. The table was rotated 360 degrees to determine the position of the highest radiation.
- b. The EUT was set 3 meters away from the interference-receiving antenna, which was mounted on the top of a variable-height antenna tower.
- c. The height of antenna is varied from one meter to four meters above the ground to determine the maximum value of the field strength. Both horizontal and vertical polarizations of the antenna are set to make the measurement.
- d. For each suspected emission, the EUT was arranged to its worst case and then the antenna was tuned to heights from 1 meter to 4 meters and the rotatable table was turned from 0 degrees to 360 degrees to find the maximum reading.
- e. The test-receiver system was set to quasi-peak detect function and specified bandwidth with maximum hold mode when the test frequency is below 1 GHz.
- f. The test-receiver system was set to peak and average detect function and specified bandwidth with maximum hold mode when the test frequency is above 1 GHz. If the peak reading value also meets average limit, measurement with the average detector is unnecessary.

Note:

1. The resolution bandwidth and video bandwidth of test receiver/spectrum analyzer is 120kHz for Quasi-peak detection (QP) at frequency below 1GHz.
2. The resolution bandwidth of test receiver/spectrum analyzer is 1 MHz and the video bandwidth is 3 MHz for Peak detection (PK) at frequency above 1GHz.
3. The resolution bandwidth of test receiver/spectrum analyzer is 1MHz and the video bandwidth is 3MHz for RMS Average (Duty cycle < 98%) for Average detection (AV) at frequency above 1GHz, then the measurement results was added to a correction factor ($10 \log(1/\text{duty cycle})$).
4. The resolution bandwidth of test receiver/spectrum analyzer is 1MHz and the video bandwidth is 10Hz (Duty cycle \geq 98%) for Average detection (AV) at frequency above 1GHz.
5. All modes of operation were investigated and the worst-case emissions are reported.

4.1.4 DEVIATION FROM TEST STANDARD

No deviation.

4.1.5 TEST SETUP

Frequency range 30MHz~1GHz

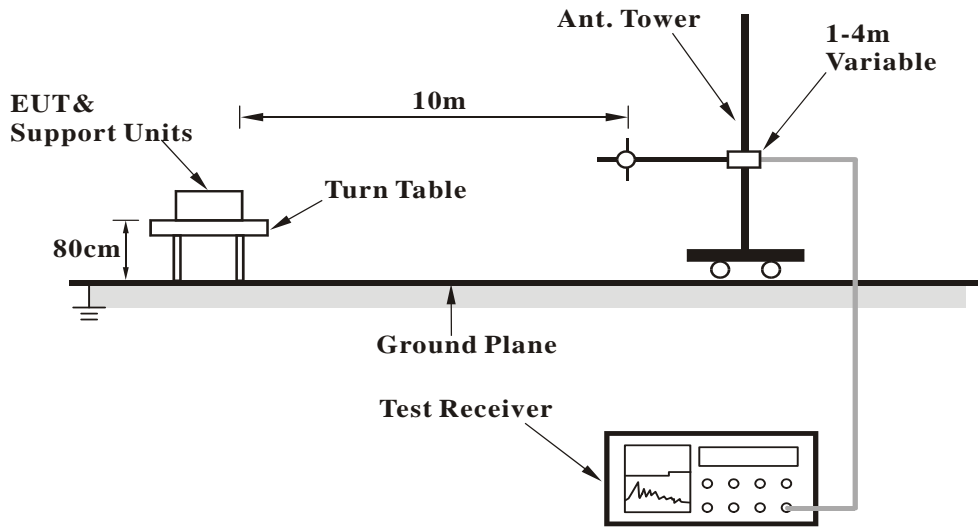

Frequency range above 1GHz

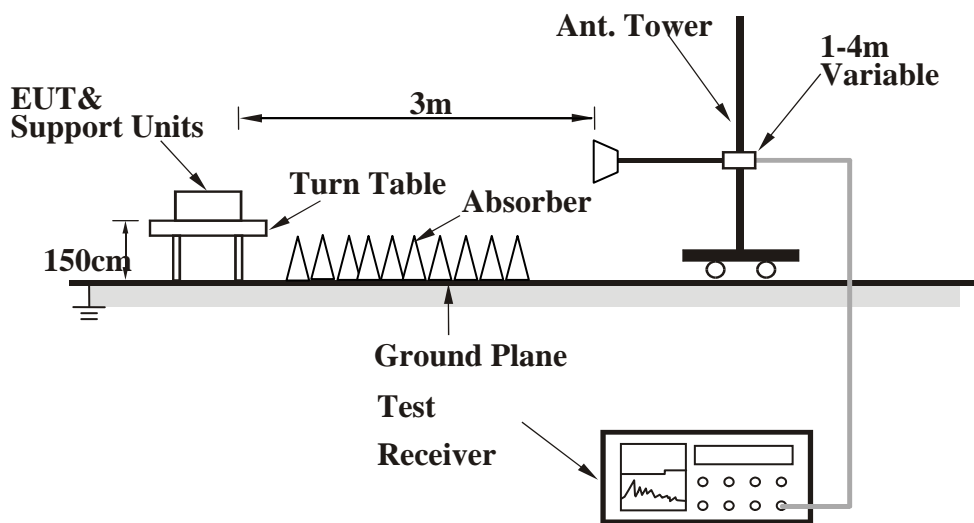

For the actual test configuration, please refer to the attached file (Test Setup Photo).

4.1.6 EUT OPERATING CONDITIONS

- a. Placed the EUT on the testing table.
- b. Prepared a notebook to act as communication partner and placed it outside of testing area.
- c. The communication partner connected with EUT via a RJ45 cable and ran a test program (provided by manufacturer) to enable EUT under transmission condition continuously at specific channel frequency.
- d. The communication partner sent data to EUT by command "PING".
- e. The necessary accessories enable the system in full functions.



A D T

4.1.7 TEST RESULTS

ABOVE 1GHz DATA :

802.11b

CHANNEL	TX Channel 1	DETECTOR FUNCTION	Peak (PK)
FREQUENCY RANGE	1GHz ~ 25GHz		Average (AV)

ANTENNA POLARITY & TEST DISTANCE: HORIZONTAL AT 3 M								
NO.	FREQ. (MHz)	EMISSION LEVEL (dBuV/m)	LIMIT (dBuV/m)	MARGIN (dB)	ANTENNA HEIGHT (m)	TABLE ANGLE (Degree)	RAW VALUE (dBuV)	CORRECTION FACTOR (dB/m)
1	2390.00	64.2 PK	74.0	-9.8	1.00 H	44	31.90	32.30
2	2390.00	52.3 AV	54.0	-1.7	1.00 H	44	20.00	32.30
3	*2412.00	113.9 PK			1.00 H	44	81.40	32.50
4	*2412.00	110.2 AV			1.00 H	44	77.70	32.50
5	2483.50	62.2 PK	74.0	-11.8	1.00 H	43	29.40	32.80
6	2483.50	49.8 AV	54.0	-4.2	1.00 H	43	17.00	32.80
7	4824.00	51.5 PK	74.0	-22.5	1.00 H	339	49.50	2.00
8	4824.00	45.6 AV	54.0	-8.4	1.00 H	339	43.60	2.00
ANTENNA POLARITY & TEST DISTANCE: VERTICAL AT 3 M								
NO.	FREQ. (MHz)	EMISSION LEVEL (dBuV/m)	LIMIT (dBuV/m)	MARGIN (dB)	ANTENNA HEIGHT (m)	TABLE ANGLE (Degree)	RAW VALUE (dBuV)	CORRECTION FACTOR (dB/m)
1	2390.00	64.6 PK	74.0	-9.4	1.16 V	6	32.30	32.30
2	2390.00	53.0 AV	54.0	-1.0	1.16 V	6	20.70	32.30
3	*2412.00	116.5 PK			1.16 V	6	84.00	32.50
4	*2412.00	112.8 AV			1.16 V	6	80.30	32.50
5	2483.50	65.9 PK	74.0	-8.1	1.09 V	5	33.10	32.80
6	2483.50	52.3 AV	54.0	-1.7	1.09 V	5	19.50	32.80
7	4824.00	49.2 PK	74.0	-24.8	1.00 V	175	47.20	2.00
8	4824.00	42.3 AV	54.0	-11.7	1.00 V	175	40.30	2.00

REMARKS:

1. Emission Level(dBuV/m) = Raw Value(dBuV) + Correction Factor(dB/m)
2. Correction Factor(dB/m) = Antenna Factor(dB/m) + Cable Factor(dB)
3. The other emission levels were very low against the limit.
4. Margin value = Emission Level – Limit value
5. " * " : Fundamental frequency.



A D T

CHANNEL	TX Channel 6	DETECTOR FUNCTION	Peak (PK)
FREQUENCY RANGE	1GHz ~ 25GHz		Average (AV)

ANTENNA POLARITY & TEST DISTANCE: HORIZONTAL AT 3 M

NO.	FREQ. (MHz)	EMISSION LEVEL (dBuV/m)	LIMIT (dBuV/m)	MARGIN (dB)	ANTENNA HEIGHT (m)	TABLE ANGLE (Degree)	RAW VALUE (dBuV)	CORRECTION FACTOR (dB/m)
1	*2437.00	112.1 PK			1.00 H	42	79.60	32.50
2	*2437.00	108.6 AV			1.00 H	42	76.10	32.50
3	2483.50	62.3 PK	74.0	-11.7	1.00 H	42	29.50	32.80
4	2483.50	50.3 AV	54.0	-3.7	1.00 H	42	17.50	32.80
5	4874.00	48.5 PK	74.0	-25.5	1.00 H	337	46.50	2.00
6	4874.00	42.3 AV	54.0	-11.7	1.00 H	337	40.30	2.00
7	7311.00	60.0 PK	74.0	-14.0	1.46 H	53	52.00	8.00
8	7311.00	52.9 AV	54.0	-1.1	1.46 H	53	44.90	8.00

ANTENNA POLARITY & TEST DISTANCE: VERTICAL AT 3 M

NO.	FREQ. (MHz)	EMISSION LEVEL (dBuV/m)	LIMIT (dBuV/m)	MARGIN (dB)	ANTENNA HEIGHT (m)	TABLE ANGLE (Degree)	RAW VALUE (dBuV)	CORRECTION FACTOR (dB/m)
1	*2437.00	115.5 PK			1.13 V	3	83.00	32.50
2	*2437.00	112.0 AV			1.13 V	3	79.50	32.50
3	2483.50	65.9 PK	74.0	-8.1	1.13 V	3	33.10	32.80
4	2483.50	52.0 AV	54.0	-2.0	1.13 V	3	19.20	32.80
5	4874.00	47.6 PK	74.0	-26.4	1.00 V	26	45.60	2.00
6	4874.00	39.0 AV	54.0	-15.0	1.00 V	26	37.00	2.00
7	7311.00	60.1 PK	74.0	-13.9	1.00 V	45	52.10	8.00
8	7311.00	52.8 AV	54.0	-1.2	1.00 V	45	44.80	8.00

REMARKS:

1. Emission Level(dBuV/m) = Raw Value(dBuV) + Correction Factor(dB/m)
2. Correction Factor(dB/m) = Antenna Factor(dB/m) + Cable Factor(dB)
3. The other emission levels were very low against the limit.
4. Margin value = Emission Level – Limit value
5. " * ": Fundamental frequency.



A D T

CHANNEL	TX Channel 11	DETECTOR FUNCTION	Peak (PK)
FREQUENCY RANGE	1GHz ~ 25GHz		Average (AV)

ANTENNA POLARITY & TEST DISTANCE: HORIZONTAL AT 3 M

NO.	FREQ. (MHz)	EMISSION LEVEL (dBuV/m)	LIMIT (dBuV/m)	MARGIN (dB)	ANTENNA HEIGHT (m)	TABLE ANGLE (Degree)	RAW VALUE (dBuV)	CORRECTION FACTOR (dB/m)
1	*2462.00	110.2 PK			1.00 H	44	77.60	32.60
2	*2462.00	106.4 AV			1.00 H	44	73.80	32.60
3	2483.50	61.8 PK	74.0	-12.2	1.00 H	44	29.00	32.80
4	2483.50	49.2 AV	54.0	-4.8	1.00 H	44	16.40	32.80
5	4924.00	48.8 PK	74.0	-25.2	1.17 H	270	46.70	2.10
6	4924.00	41.8 AV	54.0	-12.2	1.17 H	270	39.70	2.10
7	7386.00	57.9 PK	74.0	-16.1	1.00 H	350	49.80	8.10
8	7386.00	47.2 AV	54.0	-6.8	1.00 H	350	39.10	8.10

ANTENNA POLARITY & TEST DISTANCE: VERTICAL AT 3 M

NO.	FREQ. (MHz)	EMISSION LEVEL (dBuV/m)	LIMIT (dBuV/m)	MARGIN (dB)	ANTENNA HEIGHT (m)	TABLE ANGLE (Degree)	RAW VALUE (dBuV)	CORRECTION FACTOR (dB/m)
1	*2462.00	112.8 PK			1.03 V	60	80.20	32.60
2	*2462.00	109.1 AV			1.03 V	60	76.50	32.60
3	2483.50	63.2 PK	74.0	-10.8	1.03 V	60	30.40	32.80
4	2483.50	51.8 AV	54.0	-2.2	1.03 V	60	19.00	32.80
5	4924.00	47.0 PK	74.0	-27.0	1.00 V	211	44.90	2.10
6	4924.00	36.8 AV	54.0	-17.2	1.00 V	211	34.70	2.10
7	7386.00	60.0 PK	74.0	-14.0	1.57 V	319	51.90	8.10
8	7386.00	52.6 AV	54.0	-1.4	1.57 V	319	44.50	8.10

REMARKS:

1. Emission Level(dBuV/m) = Raw Value(dBuV) + Correction Factor(dB/m)
2. Correction Factor(dB/m) = Antenna Factor(dB/m) + Cable Factor(dB)
3. The other emission levels were very low against the limit.
4. Margin value = Emission Level – Limit value
5. " * ": Fundamental frequency.



A D T

802.11g

CHANNEL	TX Channel 1	DETECTOR FUNCTION	Peak (PK)
FREQUENCY RANGE	1GHz ~ 25GHz		Average (AV)

ANTENNA POLARITY & TEST DISTANCE: HORIZONTAL AT 3 M

NO.	FREQ. (MHz)	EMISSION LEVEL (dBuV/m)	LIMIT (dBuV/m)	MARGIN (dB)	ANTENNA HEIGHT (m)	TABLE ANGLE (Degree)	RAW VALUE (dBuV)	CORRECTION FACTOR (dB/m)
1	2390.00	71.8 PK	74.0	-2.2	1.01 H	58	39.50	32.30
2	2390.00	50.8 AV	54.0	-3.2	1.01 H	58	18.50	32.30
3	*2412.00	112.5 PK			1.24 H	98	80.00	32.50
4	*2412.00	102.9 AV			1.24 H	98	70.40	32.50
5	4824.00	46.8 PK	74.0	-27.2	1.00 H	15	44.80	2.00
6	4824.00	32.9 AV	54.0	-21.1	1.00 H	15	30.90	2.00

ANTENNA POLARITY & TEST DISTANCE: VERTICAL AT 3 M

NO.	FREQ. (MHz)	EMISSION LEVEL (dBuV/m)	LIMIT (dBuV/m)	MARGIN (dB)	ANTENNA HEIGHT (m)	TABLE ANGLE (Degree)	RAW VALUE (dBuV)	CORRECTION FACTOR (dB/m)
1	2390.00	72.7 PK	74.0	-1.3	1.10 V	4	40.40	32.30
2	2390.00	52.1 AV	54.0	-1.9	1.10 V	4	19.80	32.30
3	*2412.00	114.4 PK			1.13 V	16	81.90	32.50
4	*2412.00	103.8 AV			1.13 V	16	71.30	32.50
5	4824.00	47.9 PK	74.0	-26.1	1.06 V	254	45.90	2.00
6	4824.00	35.5 AV	54.0	-18.5	1.06 V	254	33.50	2.00

REMARKS:

1. Emission Level(dBuV/m) = Raw Value(dBuV) + Correction Factor(dB/m)
2. Correction Factor(dB/m) = Antenna Factor(dB/m) + Cable Factor(dB)
3. The other emission levels were very low against the limit.
4. Margin value = Emission Level – Limit value
5. " * ": Fundamental frequency.



A D T

CHANNEL	TX Channel 6	DETECTOR FUNCTION	Peak (PK)
FREQUENCY RANGE	1GHz ~ 25GHz		Average (AV)

ANTENNA POLARITY & TEST DISTANCE: HORIZONTAL AT 3 M

NO.	FREQ. (MHz)	EMISSION LEVEL (dBuV/m)	LIMIT (dBuV/m)	MARGIN (dB)	ANTENNA HEIGHT (m)	TABLE ANGLE (Degree)	RAW VALUE (dBuV)	CORRECTION FACTOR (dB/m)
1	2390.00	62.3 PK	74.0	-11.7	1.00 H	10	30.00	32.30
2	2390.00	49.3 AV	54.0	-4.7	1.00 H	10	17.00	32.30
3	*2437.00	113.5 PK			1.00 H	10	81.00	32.50
4	*2437.00	103.9 AV			1.00 H	10	71.40	32.50
5	2483.50	66.4 PK	74.0	-7.6	1.00 H	10	33.60	32.80
6	2483.50	50.4 AV	54.0	-3.6	1.00 H	10	17.60	32.80
7	4874.00	46.8 PK	74.0	-27.2	1.00 H	10	44.80	2.00
8	4874.00	34.1 AV	54.0	-19.9	1.00 H	10	32.10	2.00
9	7311.00	63.2 PK	74.0	-10.8	1.52 H	339	55.20	8.00
10	7311.00	48.0 AV	54.0	-6.0	1.52 H	339	40.00	8.00

ANTENNA POLARITY & TEST DISTANCE: VERTICAL AT 3 M

NO.	FREQ. (MHz)	EMISSION LEVEL (dBuV/m)	LIMIT (dBuV/m)	MARGIN (dB)	ANTENNA HEIGHT (m)	TABLE ANGLE (Degree)	RAW VALUE (dBuV)	CORRECTION FACTOR (dB/m)
1	2390.00	65.5 PK	74.0	-8.5	1.00 V	2	33.20	32.30
2	2390.00	49.8 AV	54.0	-4.2	1.00 V	2	17.50	32.30
3	*2437.00	117.9 PK			1.08 V	355	85.40	32.50
4	*2437.00	108.0 AV			1.08 V	355	75.50	32.50
5	2483.50	69.7 PK	74.0	-4.3	1.11 V	4	36.90	32.80
6	2483.50	52.6 AV	54.0	-1.4	1.11 V	4	19.80	32.80
7	4874.00	45.6 PK	74.0	-28.4	1.05 V	68	43.60	2.00
8	4874.00	35.6 AV	54.0	-18.4	1.05 V	68	33.60	2.00
9	7311.00	66.2 PK	74.0	-7.8	1.00 V	62	58.20	8.00
10	7311.00	48.8 AV	54.0	-5.2	1.00 V	62	40.80	8.00

REMARKS:

1. Emission Level(dBuV/m) = Raw Value(dBuV) + Correction Factor(dB/m)
2. Correction Factor(dB/m) = Antenna Factor(dB/m) + Cable Factor(dB)
3. The other emission levels were very low against the limit.
4. Margin value = Emission Level – Limit value
5. " * ": Fundamental frequency.



A D T

CHANNEL	TX Channel 11	DETECTOR FUNCTION	Peak (PK)
FREQUENCY RANGE	1GHz ~ 25GHz		Average (AV)

ANTENNA POLARITY & TEST DISTANCE: HORIZONTAL AT 3 M

NO.	FREQ. (MHz)	EMISSION LEVEL (dBuV/m)	LIMIT (dBuV/m)	MARGIN (dB)	ANTENNA HEIGHT (m)	TABLE ANGLE (Degree)	RAW VALUE (dBuV)	CORRECTION FACTOR (dB/m)
1	*2462.00	109.7 PK			1.00 H	4	77.10	32.60
2	*2462.00	100.0 AV			1.00 H	4	67.40	32.60
3	2483.50	68.8 PK	74.0	-5.2	1.00 H	0	36.00	32.80
4	2483.50	51.6 AV	54.0	-2.4	1.00 H	0	18.80	32.80
5	4924.00	47.7 PK	74.0	-26.3	1.05 H	35	45.60	2.10
6	4924.00	35.7 AV	54.0	-18.3	1.05 H	35	33.60	2.10

ANTENNA POLARITY & TEST DISTANCE: VERTICAL AT 3 M

NO.	FREQ. (MHz)	EMISSION LEVEL (dBuV/m)	LIMIT (dBuV/m)	MARGIN (dB)	ANTENNA HEIGHT (m)	TABLE ANGLE (Degree)	RAW VALUE (dBuV)	CORRECTION FACTOR (dB/m)
1	*2462.00	113.1 PK			1.06 V	33	80.50	32.60
2	*2462.00	103.2 AV			1.06 V	33	70.60	32.60
3	2483.50	72.9 PK	74.0	-1.1	1.06 V	352	40.10	32.80
4	2483.50	52.9 AV	54.0	-1.1	1.06 V	352	20.10	32.80
5	4924.00	48.0 PK	74.0	-26.0	1.02 V	57	45.90	2.10
6	4924.00	35.6 AV	54.0	-18.4	1.02 V	57	33.50	2.10

REMARKS:

1. Emission Level(dBuV/m) = Raw Value(dBuV) + Correction Factor(dB/m)
2. Correction Factor(dB/m) = Antenna Factor(dB/m) + Cable Factor(dB)
3. The other emission levels were very low against the limit.
4. Margin value = Emission Level – Limit value
5. " * ": Fundamental frequency.



A D T

802.11n (20MHz)

CHANNEL	TX Channel 1	DETECTOR FUNCTION	Peak (PK)
FREQUENCY RANGE	1GHz ~ 25GHz		Average (AV)

ANTENNA POLARITY & TEST DISTANCE: HORIZONTAL AT 3 M

NO.	FREQ. (MHz)	EMISSION LEVEL (dBuV/m)	LIMIT (dBuV/m)	MARGIN (dB)	ANTENNA HEIGHT (m)	TABLE ANGLE (Degree)	RAW VALUE (dBuV)	CORRECTION FACTOR (dB/m)
1	2390.00	67.9 PK	74.0	-6.1	1.00 H	8	35.60	32.30
2	2390.00	50.3 AV	54.0	-3.7	1.00 H	8	18.00	32.30
3	*2412.00	109.1 PK			1.00 H	8	76.60	32.50
4	*2412.00	99.8 AV			1.00 H	8	67.30	32.50
5	4824.00	46.6 PK	74.0	-27.4	1.05 H	58	44.60	2.00
6	4824.00	34.5 AV	54.0	-19.5	1.05 H	58	32.50	2.00

ANTENNA POLARITY & TEST DISTANCE: VERTICAL AT 3 M

NO.	FREQ. (MHz)	EMISSION LEVEL (dBuV/m)	LIMIT (dBuV/m)	MARGIN (dB)	ANTENNA HEIGHT (m)	TABLE ANGLE (Degree)	RAW VALUE (dBuV)	CORRECTION FACTOR (dB/m)
1	2390.00	71.8 PK	74.0	-2.2	1.13 V	24	39.50	32.30
2	2390.00	52.6 AV	54.0	-1.4	1.13 V	24	20.30	32.30
3	*2412.00	112.7 PK			1.14 V	18	80.20	32.50
4	*2412.00	102.7 AV			1.14 V	18	70.20	32.50
5	4824.00	47.7 PK	74.0	-26.3	1.20 V	305	45.70	2.00
6	4824.00	35.6 AV	54.0	-18.4	1.20 V	305	33.60	2.00

REMARKS:

1. Emission Level(dBuV/m) = Raw Value(dBuV) + Correction Factor(dB/m)
2. Correction Factor(dB/m) = Antenna Factor(dB/m) + Cable Factor(dB)
3. The other emission levels were very low against the limit.
4. Margin value = Emission Level – Limit value
5. " * ": Fundamental frequency.



A D T

CHANNEL	TX Channel 6	DETECTOR FUNCTION	Peak (PK)
FREQUENCY RANGE	1GHz ~ 25GHz		Average (AV)

ANTENNA POLARITY & TEST DISTANCE: HORIZONTAL AT 3 M

NO.	FREQ. (MHz)	EMISSION LEVEL (dBuV/m)	LIMIT (dBuV/m)	MARGIN (dB)	ANTENNA HEIGHT (m)	TABLE ANGLE (Degree)	RAW VALUE (dBuV)	CORRECTION FACTOR (dB/m)
1	2390.00	61.9 PK	74.0	-12.1	1.22 H	98	29.60	32.30
2	2390.00	49.3 AV	54.0	-4.7	1.22 H	98	17.00	32.30
3	*2437.00	113.9 PK			1.22 H	98	81.40	32.50
4	*2437.00	104.3 AV			1.22 H	98	71.80	32.50
5	2483.50	65.9 PK	74.0	-8.1	1.22 H	98	33.10	32.80
6	2483.50	49.8 AV	54.0	-4.2	1.22 H	98	17.00	32.80
7	4874.00	47.2 PK	74.0	-26.8	1.00 H	35	45.20	2.00
8	4874.00	35.5 AV	54.0	-18.5	1.00 H	35	33.50	2.00
9	7311.00	61.5 PK	74.0	-12.5	1.00 H	338	53.50	8.00
10	7311.00	47.0 AV	54.0	-7.0	1.00 H	338	39.00	8.00

ANTENNA POLARITY & TEST DISTANCE: VERTICAL AT 3 M

NO.	FREQ. (MHz)	EMISSION LEVEL (dBuV/m)	LIMIT (dBuV/m)	MARGIN (dB)	ANTENNA HEIGHT (m)	TABLE ANGLE (Degree)	RAW VALUE (dBuV)	CORRECTION FACTOR (dB/m)
1	2390.00	65.9 PK	74.0	-8.1	1.13 V	18	33.60	32.30
2	2390.00	50.9 AV	54.0	-3.1	1.13 V	18	18.60	32.30
3	*2437.00	117.3 PK			1.10 V	3	84.80	32.50
4	*2437.00	107.3 AV			1.10 V	3	74.80	32.50
5	2483.50	70.4 PK	74.0	-3.6	1.07 V	5	37.60	32.80
6	2483.50	53.0 AV	54.0	-1.0	1.07 V	5	20.20	32.80
7	4874.00	47.2 PK	74.0	-26.8	1.52 V	16	45.20	2.00
8	4874.00	36.5 AV	54.0	-17.5	1.52 V	16	34.50	2.00
9	7311.00	63.0 PK	74.0	-11.0	1.00 V	61	55.00	8.00
10	7311.00	48.6 AV	54.0	-5.4	1.00 V	61	40.60	8.00

REMARKS:

1. Emission Level(dBuV/m) = Raw Value(dBuV) + Correction Factor(dB/m)
2. Correction Factor(dB/m) = Antenna Factor(dB/m) + Cable Factor(dB)
3. The other emission levels were very low against the limit.
4. Margin value = Emission Level – Limit value
5. " * ": Fundamental frequency.



A D T

CHANNEL	TX Channel 11	DETECTOR FUNCTION	Peak (PK)
FREQUENCY RANGE	1GHz ~ 25GHz		Average (AV)

ANTENNA POLARITY & TEST DISTANCE: HORIZONTAL AT 3 M								
NO.	FREQ. (MHz)	EMISSION LEVEL (dBuV/m)	LIMIT (dBuV/m)	MARGIN (dB)	ANTENNA HEIGHT (m)	TABLE ANGLE (Degree)	RAW VALUE (dBuV)	CORRECTION FACTOR (dB/m)
1	*2462.00	108.8 PK			1.00 H	7	76.20	32.60
2	*2462.00	99.0 AV			1.00 H	7	66.40	32.60
3	2483.50	66.6 PK	74.0	-7.4	1.00 H	7	33.80	32.80
4	2483.50	50.8 AV	54.0	-3.2	1.00 H	7	18.00	32.80
5	4924.00	46.3 PK	74.0	-27.7	1.23 H	63	44.20	2.10
6	4924.00	34.6 AV	54.0	-19.4	1.23 H	63	32.50	2.10
ANTENNA POLARITY & TEST DISTANCE: VERTICAL AT 3 M								
NO.	FREQ. (MHz)	EMISSION LEVEL (dBuV/m)	LIMIT (dBuV/m)	MARGIN (dB)	ANTENNA HEIGHT (m)	TABLE ANGLE (Degree)	RAW VALUE (dBuV)	CORRECTION FACTOR (dB/m)
1	*2462.00	113.2 PK			1.06 V	33	80.60	32.60
2	*2462.00	102.7 AV			1.06 V	33	70.10	32.60
3	2483.50	71.6 PK	74.0	-2.4	1.05 V	59	38.80	32.80
4	2483.50	52.7 AV	54.0	-1.3	1.05 V	59	19.90	32.80
5	4924.00	47.7 PK	74.0	-26.3	1.62 V	352	45.60	2.10
6	4924.00	35.6 AV	54.0	-18.4	1.62 V	352	33.50	2.10

REMARKS:

1. Emission Level(dBuV/m) = Raw Value(dBuV) + Correction Factor(dB/m)
2. Correction Factor(dB/m) = Antenna Factor(dB/m) + Cable Factor(dB)
3. The other emission levels were very low against the limit.
4. Margin value = Emission Level – Limit value
5. " * ": Fundamental frequency.



A D T

802.11n (40MHz)

CHANNEL	TX Channel 3	DETECTOR FUNCTION	Peak (PK)
FREQUENCY RANGE	1GHz ~ 25GHz		Average (AV)

ANTENNA POLARITY & TEST DISTANCE: HORIZONTAL AT 3 M

NO.	FREQ. (MHz)	EMISSION LEVEL (dBuV/m)	LIMIT (dBuV/m)	MARGIN (dB)	ANTENNA HEIGHT (m)	TABLE ANGLE (Degree)	RAW VALUE (dBuV)	CORRECTION FACTOR (dB/m)
1	2390.00	65.7 PK	74.0	-8.3	1.00 H	100	33.40	32.30
2	2390.00	51.5 AV	54.0	-2.5	1.00 H	100	19.20	32.30
3	*2422.00	104.2 PK			1.00 H	100	71.70	32.50
4	*2422.00	95.3 AV			1.00 H	100	62.80	32.50
5	4844.00	48.9 PK	74.0	-25.1	1.21 H	69	46.90	2.00
6	4844.00	35.8 AV	54.0	-18.2	1.21 H	69	33.80	2.00

ANTENNA POLARITY & TEST DISTANCE: VERTICAL AT 3 M

NO.	FREQ. (MHz)	EMISSION LEVEL (dBuV/m)	LIMIT (dBuV/m)	MARGIN (dB)	ANTENNA HEIGHT (m)	TABLE ANGLE (Degree)	RAW VALUE (dBuV)	CORRECTION FACTOR (dB/m)
1	2390.00	66.9 PK	74.0	-7.1	1.36 V	350	34.60	32.30
2	2390.00	52.5 AV	54.0	-1.5	1.36 V	350	20.20	32.30
3	*2422.00	108.5 PK			1.10 V	355	76.00	32.50
4	*2422.00	97.8 AV			1.10 V	355	65.30	32.50
5	4844.00	48.5 PK	74.0	-25.5	1.62 V	34	46.50	2.00
6	4844.00	35.6 AV	54.0	-18.4	1.62 V	34	33.60	2.00

REMARKS:

1. Emission Level(dBuV/m) = Raw Value(dBuV) + Correction Factor(dB/m)
2. Correction Factor(dB/m) = Antenna Factor(dB/m) + Cable Factor(dB)
3. The other emission levels were very low against the limit.
4. Margin value = Emission Level – Limit value
5. " * ": Fundamental frequency.



A D T

CHANNEL	TX Channel 6	DETECTOR FUNCTION	Peak (PK)
FREQUENCY RANGE	1GHz ~ 25GHz		Average (AV)

ANTENNA POLARITY & TEST DISTANCE: HORIZONTAL AT 3 M

NO.	FREQ. (MHz)	EMISSION LEVEL (dBuV/m)	LIMIT (dBuV/m)	MARGIN (dB)	ANTENNA HEIGHT (m)	TABLE ANGLE (Degree)	RAW VALUE (dBuV)	CORRECTION FACTOR (dB/m)
1	2390.00	64.0 PK	74.0	-10.0	1.00 H	96	31.70	32.30
2	2390.00	50.6 AV	54.0	-3.4	1.00 H	96	18.30	32.30
3	*2437.00	106.2 PK			1.00 H	3	73.70	32.50
4	*2437.00	96.5 AV			1.00 H	3	64.00	32.50
5	2483.50	65.4 PK	74.0	-8.6	1.00 H	352	32.60	32.80
6	2483.50	51.2 AV	54.0	-2.8	1.00 H	352	18.40	32.80
7	4874.00	45.3 PK	74.0	-28.7	1.00 H	27	43.30	2.00
8	4874.00	33.0 AV	54.0	-21.0	1.00 H	27	31.00	2.00
9	7311.00	54.2 PK	74.0	-19.8	1.00 H	348	46.20	8.00
10	7311.00	41.3 AV	54.0	-12.7	1.00 H	348	33.30	8.00

ANTENNA POLARITY & TEST DISTANCE: VERTICAL AT 3 M

NO.	FREQ. (MHz)	EMISSION LEVEL (dBuV/m)	LIMIT (dBuV/m)	MARGIN (dB)	ANTENNA HEIGHT (m)	TABLE ANGLE (Degree)	RAW VALUE (dBuV)	CORRECTION FACTOR (dB/m)
1	2390.00	66.4 PK	74.0	-7.6	1.12 V	22	34.10	32.30
2	2390.00	51.7 AV	54.0	-2.3	1.12 V	22	19.40	32.30
3	*2437.00	108.4 PK			1.09 V	2	75.90	32.50
4	*2437.00	98.1 AV			1.09 V	2	65.60	32.50
5	2483.50	70.1 PK	74.0	-3.9	1.07 V	347	37.30	32.80
6	2483.50	53.0 AV	54.0	-1.0	1.07 V	347	20.20	32.80
7	4874.00	45.1 PK	74.0	-28.9	1.00 V	126	43.10	2.00
8	4874.00	32.2 AV	54.0	-21.8	1.00 V	126	30.20	2.00
9	7311.00	62.1 PK	74.0	-11.9	1.14 V	358	54.10	8.00
10	7311.00	48.5 AV	54.0	-5.5	1.14 V	358	40.50	8.00

REMARKS:

1. Emission Level(dBuV/m) = Raw Value(dBuV) + Correction Factor(dB/m)
2. Correction Factor(dB/m) = Antenna Factor(dB/m) + Cable Factor(dB)
3. The other emission levels were very low against the limit.
4. Margin value = Emission Level – Limit value
5. " * ": Fundamental frequency.



A D T

CHANNEL	TX Channel 9	DETECTOR FUNCTION	Peak (PK)
FREQUENCY RANGE	1GHz ~ 25GHz		Average (AV)

ANTENNA POLARITY & TEST DISTANCE: HORIZONTAL AT 3 M

NO.	FREQ. (MHz)	EMISSION LEVEL (dBuV/m)	LIMIT (dBuV/m)	MARGIN (dB)	ANTENNA HEIGHT (m)	TABLE ANGLE (Degree)	RAW VALUE (dBuV)	CORRECTION FACTOR (dB/m)
1	*2452.00	103.1 PK			1.00 H	2	70.50	32.60
2	*2452.00	93.8 AV			1.00 H	2	61.20	32.60
3	2483.50	64.0 PK	74.0	-10.0	1.00 H	0	31.20	32.80
4	2483.50	51.3 AV	54.0	-2.7	1.00 H	0	18.50	32.80
5	4904.00	45.6 PK	74.0	-28.4	1.00 H	102	43.50	2.10
6	4904.00	33.0 AV	54.0	-21.0	1.00 H	102	30.90	2.10

ANTENNA POLARITY & TEST DISTANCE: VERTICAL AT 3 M

NO.	FREQ. (MHz)	EMISSION LEVEL (dBuV/m)	LIMIT (dBuV/m)	MARGIN (dB)	ANTENNA HEIGHT (m)	TABLE ANGLE (Degree)	RAW VALUE (dBuV)	CORRECTION FACTOR (dB/m)
1	*2452.00	105.9 PK			1.36 V	12	73.30	32.60
2	*2452.00	96.3 AV			1.36 V	12	63.70	32.60
3	2483.50	67.3 PK	74.0	-6.7	1.06 V	18	34.50	32.80
4	2483.50	53.0 AV	54.0	-1.0	1.06 V	18	20.20	32.80
5	4904.00	45.2 PK	74.0	-28.8	1.00 V	96	43.10	2.10
6	4904.00	32.1 AV	54.0	-21.9	1.00 V	96	30.00	2.10

REMARKS:

1. Emission Level(dBuV/m) = Raw Value(dBuV) + Correction Factor(dB/m)
2. Correction Factor(dB/m) = Antenna Factor(dB/m) + Cable Factor(dB)
3. The other emission levels were very low against the limit.
4. Margin value = Emission Level – Limit value
5. " * ": Fundamental frequency.



A D T

BELOW 1GHz WORST-CASE DATA

802.11g

CHANNEL	TX Channel 6	DETECTOR FUNCTION	Quasi-Peak (QP)
FREQUENCY RANGE	30MHz ~ 1GHz		
TEST MODE	A		

ANTENNA POLARITY & TEST DISTANCE: HORIZONTAL AT 3 M

NO.	FREQ. (MHz)	EMISSION LEVEL (dBuV/m)	LIMIT (dBuV/m)	MARGIN (dB)	ANTENNA HEIGHT (m)	TABLE ANGLE (Degree)	RAW VALUE (dBuV)	CORRECTION FACTOR (dB/m)
1	76.60	28.6 QP	40.0	-11.4	1.51 H	267	46.20	-17.60
2	121.70	31.5 QP	43.5	-12.0	1.51 H	286	47.50	-16.00
3	238.30	25.6 QP	46.0	-20.4	1.00 H	75	40.30	-14.70
4	434.20	28.7 QP	46.0	-17.3	1.51 H	208	38.70	-10.00
5	499.50	32.2 QP	46.0	-13.8	1.51 H	135	41.20	-9.00
6	801.00	31.4 QP	46.0	-14.6	1.51 H	304	34.60	-3.20

ANTENNA POLARITY & TEST DISTANCE: VERTICAL AT 3 M

NO.	FREQ. (MHz)	EMISSION LEVEL (dBuV/m)	LIMIT (dBuV/m)	MARGIN (dB)	ANTENNA HEIGHT (m)	TABLE ANGLE (Degree)	RAW VALUE (dBuV)	CORRECTION FACTOR (dB/m)
1	42.40	31.9 QP	40.0	-8.1	1.00 V	282	46.30	-14.40
2	76.60	34.6 QP	40.0	-5.4	1.00 V	274	52.20	-17.60
3	123.30	32.6 QP	43.5	-10.9	1.00 V	53	48.50	-15.90
4	400.00	28.3 QP	46.0	-17.7	1.49 V	52	39.10	-10.80
5	499.50	31.3 QP	46.0	-14.7	1.00 V	27	40.30	-9.00
6	801.00	35.5 QP	46.0	-10.5	1.24 V	15	38.70	-3.20

REMARKS:

1. Emission Level(dBuV/m) = Raw Value(dBuV) + Correction Factor(dB/m)
2. Correction Factor(dB/m) = Antenna Factor(dB/m) + Cable Factor(dB)
3. The other emission levels were very low against the limit.
4. Margin value = Emission Level – Limit value



A D T

CHANNEL	TX Channel 6	DETECTOR FUNCTION	Quasi-Peak (QP)
FREQUENCY RANGE	30MHz ~ 1GHz		
TEST MODE	B		

ANTENNA POLARITY & TEST DISTANCE: HORIZONTAL AT 3 M

NO.	FREQ. (MHz)	EMISSION LEVEL (dBuV/m)	LIMIT (dBuV/m)	MARGIN (dB)	ANTENNA HEIGHT (m)	TABLE ANGLE (Degree)	RAW VALUE (dBuV)	CORRECTION FACTOR (dB/m)
1	97.90	29.6 QP	43.50	-13.90	1.99 H	256	48.90	-19.30
2	159.98	28.5 QP	43.50	-15.00	1.00 H	267	42.50	-14.00
3	165.80	29.2 QP	43.50	-14.30	1.99 H	90	43.50	-14.30
4	499.48	32.8 QP	46.00	-13.20	1.99 H	250	41.50	-8.70
5	802.12	34.7 QP	46.00	-11.30	1.00 H	327	37.50	-2.80
6	825.40	32.3 QP	46.00	-13.70	1.00 H	94	34.80	-2.50
7	924.34	30.6 QP	46.00	-15.40	1.00 H	144	31.30	-0.70

ANTENNA POLARITY & TEST DISTANCE: VERTICAL AT 3 M

NO.	FREQ. (MHz)	EMISSION LEVEL (dBuV/m)	LIMIT (dBuV/m)	MARGIN (dB)	ANTENNA HEIGHT (m)	TABLE ANGLE (Degree)	RAW VALUE (dBuV)	CORRECTION FACTOR (dB/m)
1	47.46	33.9 QP	40.00	-6.10	1.00 V	327	48.40	-14.50
2	68.80	32.6 QP	40.00	-7.40	1.00 V	18	48.50	-15.90
3	97.90	30.4 QP	43.50	-13.10	1.00 V	254	49.70	-19.30
4	499.48	33.5 QP	46.00	-12.50	1.00 V	130	42.20	-8.70
5	802.12	36.5 QP	46.00	-9.50	2.00 V	15	39.30	-2.80
6	901.06	32.7 QP	46.00	-13.30	1.00 V	42	34.00	-1.30

REMARKS:

1. Emission Level(dBuV/m) = Raw Value(dBuV) + Correction Factor(dB/m)
2. Correction Factor(dB/m) = Antenna Factor(dB/m) + Cable Factor(dB)
3. The other emission levels were very low against the limit.
4. Margin value = Emission Level – Limit value



A D T

CHANNEL	TX Channel 6	DETECTOR FUNCTION	Quasi-Peak (QP)
FREQUENCY RANGE	30MHz ~ 1GHz		
TEST MODE	C		

ANTENNA POLARITY & TEST DISTANCE: HORIZONTAL AT 3 M								
NO.	FREQ. (MHz)	EMISSION LEVEL (dBuV/m)	LIMIT (dBuV/m)	MARGIN (dB)	ANTENNA HEIGHT (m)	TABLE ANGLE (Degree)	RAW VALUE (dBuV)	CORRECTION FACTOR (dB/m)
1	31.84	30.2 QP	40.0	-9.8	1.01 H	16	46.20	-16.00
2	121.28	27.4 QP	43.5	-16.1	1.51 H	249	43.50	-16.10
3	189.33	34.6 QP	43.5	-8.9	1.51 H	261	50.90	-16.30
4	237.94	34.6 QP	46.0	-11.4	1.01 H	281	49.60	-15.00
5	329.32	30.7 QP	46.0	-15.3	1.01 H	210	42.40	-11.70
6	500.42	36.0 QP	46.0	-10.0	1.01 H	151	44.40	-8.40
ANTENNA POLARITY & TEST DISTANCE: VERTICAL AT 3 M								
NO.	FREQ. (MHz)	EMISSION LEVEL (dBuV/m)	LIMIT (dBuV/m)	MARGIN (dB)	ANTENNA HEIGHT (m)	TABLE ANGLE (Degree)	RAW VALUE (dBuV)	CORRECTION FACTOR (dB/m)
1	31.84	29.2 QP	40.0	-10.8	1.99 V	9	45.20	-16.00
2	237.94	32.6 QP	46.0	-13.4	1.99 V	124	47.60	-15.00
3	286.55	29.4 QP	46.0	-16.6	1.49 V	30	42.10	-12.70
4	327.38	31.3 QP	46.0	-14.7	1.49 V	151	43.00	-11.70
5	500.42	32.1 QP	46.0	-13.9	1.99 V	202	40.50	-8.40
6	799.84	33.3 QP	46.0	-12.7	1.49 V	14	35.50	-2.20

REMARKS:

1. Emission Level(dBuV/m) = Raw Value(dBuV) + Correction Factor(dB/m)
2. Correction Factor(dB/m) = Antenna Factor(dB/m) + Cable Factor(dB)
3. The other emission levels were very low against the limit.
4. Margin value = Emission Level – Limit value

4.2 CONDUCTED EMISSION MEASUREMENT

4.2.1 LIMITS OF CONDUCTED EMISSION MEASUREMENT

FREQUENCY OF EMISSION (MHz)	CONDUCTED LIMIT (dB μ V)	
	Quasi-peak	Average
0.15 ~ 0.5	66 to 56	56 to 46
0.5 ~ 5	56	46
5 ~ 30	60	50

- NOTE:**
1. The lower limit shall apply at the transition frequencies.
 2. The limit decreases in line with the logarithm of the frequency in the range of 0.15 to 0.50MHz.
 3. All emanations from a class A/B digital device or system, including any network of conductors and apparatus connected thereto, shall not exceed the level of field strengths specified above.

4.2.2 TEST INSTRUMENTS

Tested Date: Aug. 07 ~ Oct. 15, 2014

DESCRIPTION & MANUFACTURER	MODEL NO.	SERIAL NO.	DATE OF CALIBRATION	DUE DATE OF CALIBRATION
Test Receiver ROHDE & SCHWARZ	ESCI	100612	Sep. 30, 2014	Sep. 29, 2015
RF signal cable Woken	5D-FB	Cable-HYC01-01	Dec. 27, 2013	Dec. 26, 2014
LISN ROHDE & SCHWARZ (EUT)	ESH3-Z5	835239/001	Feb. 13, 2014	Feb. 12, 2015
LISN ROHDE & SCHWARZ (Peripheral)	ESH3-Z5	100311	Jul. 21, 2014	Jul. 20, 2015
Software ADT	BV ADT_Cond_ V7.3.7.3	NA	NA	NA

- NOTE:**
1. The calibration interval of the above test instruments is 12 months and the calibrations are traceable to NML/ROC and NIST/USA.
 2. The test was performed in HwaYa Shielded Room 1.
 3. The VCCI Site Registration No. is C-2040.



A D T

Tested Date: Jan. 23 ~ Jan. 29, 2015

DESCRIPTION & MANUFACTURER	MODEL NO.	SERIAL NO.	DATE OF CALIBRATION	DUE DATE OF CALIBRATION
Test Receiver ROHDE & SCHWARZ	ESCI	100612	Sep. 30, 2014	Sep. 29, 2015
RF signal cable Woken	5D-FB	Cable-HYC01-01	Dec. 26, 2014	Dec. 25, 2015
LISN ROHDE & SCHWARZ (EUT)	ESH3-Z5	835239/001	Feb. 13, 2014	Feb. 12, 2015
LISN ROHDE & SCHWARZ (Peripheral)	ESH3-Z5	100311	Jul. 21, 2014	Jul. 20, 2015
Software ADT	BV ADT_Cond_ V7.3.7.3	NA	NA	NA

- NOTE:** 1. The calibration interval of the above test instruments is 12 months and the calibrations are traceable to NML/ROC and NIST/USA.
2. The test was performed in HwaYa Shielded Room 1.
3. The VCCI Site Registration No. is C-2040.

Tested Date: Apr. 17, 2015

DESCRIPTION & MANUFACTURER	MODEL NO.	SERIAL NO.	DATE OF CALIBRATION	DUE DATE OF CALIBRATION
Test Receiver ROHDE & SCHWARZ	ESCI	100613	Nov. 11, 2014	Nov. 10, 2015
RF signal cable Woken	5D-FB	Cable-HYC01-01	Dec. 26, 2014	Dec. 25, 2015
LISN ROHDE & SCHWARZ (EUT)	ESH3-Z5	835239/001	Mar. 02, 2015	Mar. 01, 2016
LISN ROHDE & SCHWARZ (Peripheral)	ESH3-Z5	100311	Jul. 21, 2014	Jul. 20, 2015
Software ADT	BV ADT_Cond_ V7.3.7.3	NA	NA	NA

- NOTE:** 1. The calibration interval of the above test instruments is 12 months and the calibrations are traceable to NML/ROC and NIST/USA.
2. The test was performed in HwaYa Shielded Room 1.
3. The VCCI Site Registration No. is C-2040.

4.2.3 TEST PROCEDURES

- a. The EUT was placed 0.4 meters from the conducting wall of the shielded room with EUT being connected to the power mains through a line impedance stabilization network (LISN). Other support units were connected to the power mains through another LISN. The two LISNs provide 50 ohm/ 50uH of coupling impedance for the measuring instrument.
- b. Both lines of the power mains connected to the EUT were checked for maximum conducted interference.
- c. The frequency range from 150kHz to 30MHz was searched. Emission levels under (Limit - 20dB) was not recorded.

NOTE: All modes of operation were investigated and the worst-case emissions are reported.

4.2.4 DEVIATION FROM TEST STANDARD

No deviation.

4.2.5 TEST SETUP

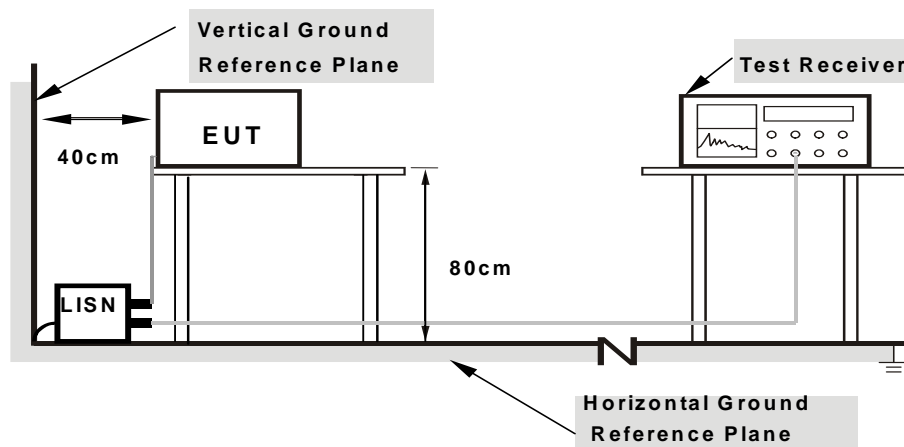

Note: 1.Support units were connected to second LISN.
 2.Both of LISNs (AMN) are 80 cm from EUT and at least 80 from other units and other metal planes

For the actual test configuration, please refer to the attached file (Test Setup Photo).

4.2.6 EUT OPERATING CONDITIONS

Same as 4.1.6.

4.2.7 TEST RESULTS

CONDUCTED WORST-CASE DATA : 802.11g

PHASE	Line 1	6dB BANDWIDTH	9kHz
TEST MODE	A		

No	Freq. [MHz]	Corr. Factor (dB)	Reading Value		Emission Level		Limit		Margin	
			[dB (uV)]		[dB (uV)]		[dB (uV)]		(dB)	
			Q.P.	AV.	Q.P.	AV.	Q.P.	AV.	Q.P.	AV.
1	0.16562	0.10	44.23	28.03	44.33	28.13	65.18	55.18	-20.84	-27.04
2	0.21250	0.09	38.71	17.91	38.80	18.00	63.11	53.11	-24.31	-35.11
3	0.43125	0.12	38.71	17.21	38.83	17.33	57.23	47.23	-18.40	-29.90
4	0.65781	0.15	28.49	14.59	28.64	14.74	56.00	46.00	-27.36	-31.26
5	1.54688	0.23	21.13	10.59	21.36	10.82	56.00	46.00	-34.64	-35.18
6	13.90234	0.77	32.95	25.11	33.72	25.88	60.00	50.00	-26.28	-24.12

REMARKS:

1. Q.P. and AV. are abbreviations of quasi-peak and average individually.
2. The emission levels of other frequencies were very low against the limit.
3. Margin value = Emission level - Limit value
4. Correction factor = Insertion loss + Cable loss
5. Emission Level = Correction Factor + Reading Value.

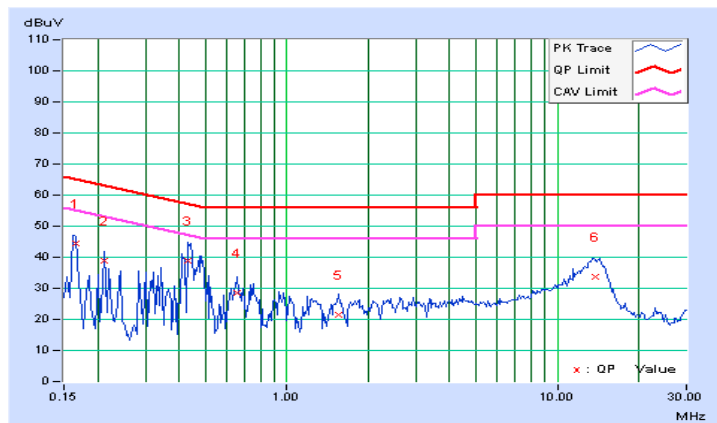

PHASE	Line 2	6dB BANDWIDTH	9kHz
TEST MODE	A		

No	Freq. [MHz]	Corr. Factor (dB)	Reading Value		Emission Level		Limit		Margin	
			[dB (uV)]		[dB (uV)]		[dB (uV)]		(dB)	
			Q.P.	AV.	Q.P.	AV.	Q.P.	AV.	Q.P.	AV.
1	0.16172	0.06	45.67	31.05	45.73	31.11	65.38	55.38	-19.65	-24.27
2	0.19687	0.09	39.05	22.31	39.14	22.40	63.74	53.74	-24.60	-31.34
3	0.43516	0.17	38.13	25.03	38.30	25.20	57.15	47.15	-18.85	-21.95
4	1.19922	0.22	27.45	17.49	27.67	17.71	56.00	46.00	-28.33	-28.29
5	2.23047	0.22	28.65	19.81	28.87	20.03	56.00	46.00	-27.13	-25.97
6	14.49219	0.76	28.65	21.15	29.41	21.91	60.00	50.00	-30.59	-28.09

REMARKS:

1. Q.P. and AV. are abbreviations of quasi-peak and average individually.
2. The emission levels of other frequencies were very low against the limit.
3. Margin value = Emission level - Limit value
4. Correction factor = Insertion loss + Cable loss
5. Emission Level = Correction Factor + Reading Value.

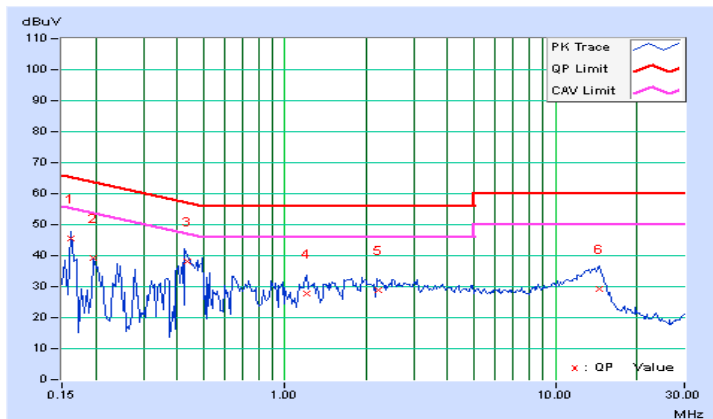

PHASE	Line 1	6dB BANDWIDTH	9kHz
TEST MODE	B		

No	Freq. [MHz]	Corr. Factor (dB)	Reading Value		Emission Level		Limit		Margin	
			[dB (uV)]		[dB (uV)]		[dB (uV)]		(dB)	
			Q.P.	AV.	Q.P.	AV.	Q.P.	AV.	Q.P.	AV.
1	0.16181	0.05	47.79	37.42	47.84	37.47	65.37	55.37	-17.53	-17.90
2	0.23216	0.06	36.86	29.62	36.92	29.68	62.37	52.37	-25.45	-22.69
3	0.36143	0.06	42.51	40.27	42.57	40.33	58.70	48.70	-16.13	-8.37
4	0.52544	0.06	23.92	18.63	23.98	18.69	56.00	46.00	-32.02	-27.31
5	4.43927	0.21	28.46	19.21	28.67	19.42	56.00	46.00	-27.33	-26.58
6	21.51033	0.94	41.12	32.41	42.06	33.35	60.00	50.00	-17.94	-16.65

REMARKS:

1. Q.P. and AV. are abbreviations of quasi-peak and average individually.
2. The emission levels of other frequencies were very low against the limit.
3. Margin value = Emission level - Limit value
4. Correction factor = Insertion loss + Cable loss
5. Emission Level = Correction Factor + Reading Value.

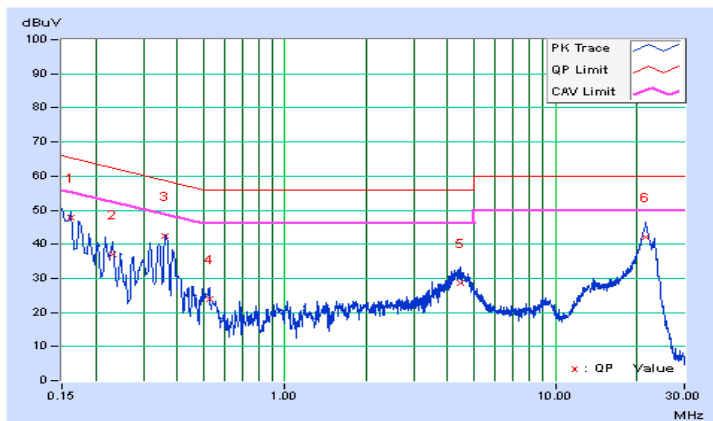

PHASE	Line 2	6dB BANDWIDTH	9kHz
TEST MODE	B		

No	Freq. [MHz]	Corr. Factor (dB)	Reading Value		Emission Level		Limit		Margin	
			[dB (uV)]		[dB (uV)]		[dB (uV)]		(dB)	
			Q.P.	AV.	Q.P.	AV.	Q.P.	AV.	Q.P.	AV.
1	0.15802	0.05	48.89	38.19	48.94	38.24	65.57	55.57	-16.63	-17.33
2	0.20458	0.05	40.91	29.51	40.96	29.56	63.42	53.42	-22.46	-23.86
3	0.35953	0.06	40.69	37.63	40.75	37.69	58.74	48.74	-17.99	-11.05
4	0.52130	0.06	24.59	18.13	24.65	18.19	56.00	46.00	-31.35	-27.81
5	4.36889	0.20	28.32	18.58	28.52	18.78	56.00	46.00	-27.48	-27.22
6	21.61590	0.75	41.08	32.98	41.83	33.73	60.00	50.00	-18.17	-16.27

REMARKS:

1. Q.P. and AV. are abbreviations of quasi-peak and average individually.
2. The emission levels of other frequencies were very low against the limit.
3. Margin value = Emission level - Limit value
4. Correction factor = Insertion loss + Cable loss
5. Emission Level = Correction Factor + Reading Value.

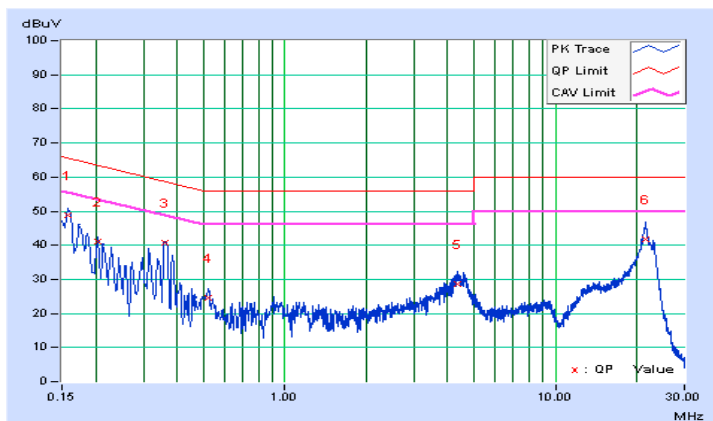



A D T

PHASE	Line 1	6dB BANDWIDTH	9kHz
TEST MODE	C		

No	Freq. [MHz]	Corr. Factor (dB)	Reading Value		Emission Level		Limit		Margin	
			[dB (uV)]		[dB (uV)]		[dB (uV)]		(dB)	
			Q.P.	AV.	Q.P.	AV.	Q.P.	AV.	Q.P.	AV.
1	0.50000	0.13	44.12	31.62	44.25	31.75	56.00	46.00	-11.75	-14.25
2	2.45299	0.25	41.97	41.57	42.22	41.82	56.00	46.00	-13.78	-4.18
3	3.18807	0.26	44.42	44.07	44.68	44.33	56.00	46.00	-11.32	-1.67
4	3.67682	0.26	44.14	43.61	44.40	43.87	56.00	46.00	-11.60	-2.13
5	3.92315	0.26	44.33	43.62	44.59	43.88	56.00	46.00	-11.41	-2.12
6	4.41190	0.28	41.89	41.59	42.17	41.87	56.00	46.00	-13.83	-4.13

REMARKS:

1. Q.P. and AV. are abbreviations of quasi-peak and average individually.
2. The emission levels of other frequencies were very low against the limit.
3. Margin value = Emission level - Limit value
4. Correction factor = Insertion loss + Cable loss
5. Emission Level = Correction Factor + Reading Value.

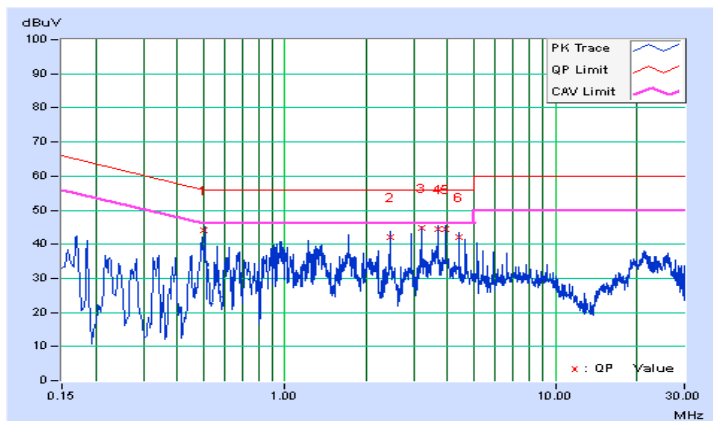



A D T

PHASE	Line 2	6dB BANDWIDTH	9kHz
TEST MODE	C		

No	Freq. [MHz]	Corr. Factor (dB)	Reading Value		Emission Level		Limit		Margin	
			[dB (uV)]		[dB (uV)]		[dB (uV)]		(dB)	
			Q.P.	AV.	Q.P.	AV.	Q.P.	AV.	Q.P.	AV.
1	0.49064	0.18	39.65	35.43	39.83	35.61	56.16	46.16	-16.33	-10.55
2	2.44908	0.23	41.06	40.67	41.29	40.90	56.00	46.00	-14.71	-5.10
3	3.18591	0.24	45.22	44.32	45.46	44.56	56.00	46.00	-10.54	-1.44
4	3.67682	0.25	44.85	43.76	45.10	44.01	56.00	46.00	-10.90	-1.99
5	3.91924	0.26	43.26	41.81	43.52	42.07	56.00	46.00	-12.48	-3.93
6	4.41190	0.28	43.04	42.24	43.32	42.52	56.00	46.00	-12.68	-3.48

REMARKS:

1. Q.P. and AV. are abbreviations of quasi-peak and average individually.
2. The emission levels of other frequencies were very low against the limit.
3. Margin value = Emission level - Limit value
4. Correction factor = Insertion loss + Cable loss
5. Emission Level = Correction Factor + Reading Value.

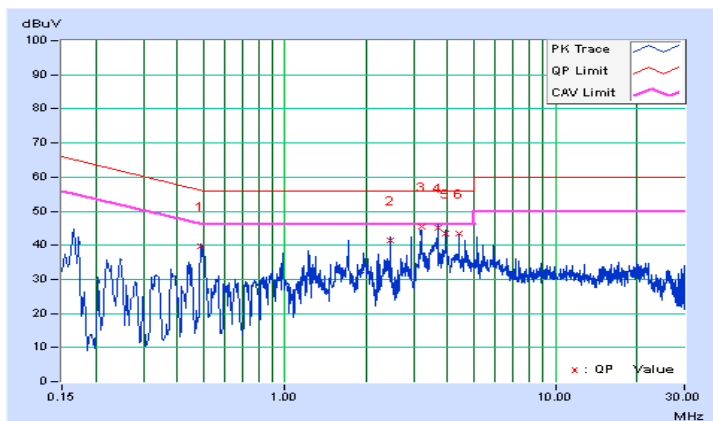

4.3 6dB BANDWIDTH MEASUREMENT

4.3.1 LIMITS OF 6dB BANDWIDTH MEASUREMENT

The minimum of 6dB Bandwidth Measurement is 0.5 MHz.

4.3.2 TEST SETUP

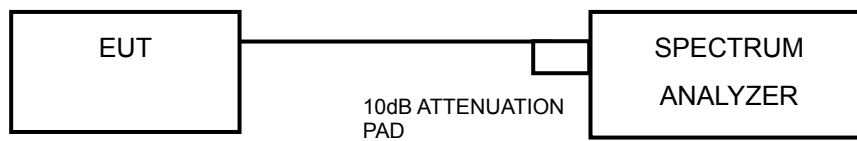

4.3.3 TEST INSTRUMENTS

Refer to section 4.1.2 to get information of above instrument.

4.3.4 TEST PROCEDURE

- a. Set resolution bandwidth (RBW) = 100kHz
- b. Set the video bandwidth (VBW) $\geq 3 \times$ RBW, Detector = Peak.
- c. Trace mode = max hold.
- d. Sweep = auto couple.
- e. Measure the maximum width of the emission that is constrained by the frequencies associated with the two amplitude points (upper and lower) that are attenuated by 6 dB relative to the maximum level measured in the fundamental emission

4.3.5 DEVIATION FROM TEST STANDARD

No deviation.

4.3.6 EUT OPERATING CONDITIONS

The software provided by client to enable the EUT under transmission condition continuously at lowest, middle and highest channel frequencies individually.



4.3.7 TEST RESULTS

802.11b

CHANNEL	FREQUENCY (MHz)	6dB BANDWIDTH (MHz)	MINIMUM LIMIT (MHz)	PASS / FAIL
1	2412	8.09	0.5	PASS
6	2437	8.10	0.5	PASS
11	2462	8.10	0.5	PASS

802.11g

CHANNEL	FREQUENCY (MHz)	6dB BANDWIDTH (MHz)		MINIMUM LIMIT (MHz)	PASS / FAIL
		CHAIN 0	CHAIN 1		
1	2412	16.42	16.36	0.5	PASS
6	2437	16.41	16.42	0.5	PASS
11	2462	16.38	16.43	0.5	PASS

802.11n (20MHz)

CHANNEL	FREQUENCY (MHz)	6dB BANDWIDTH (MHz)		MINIMUM LIMIT (MHz)	PASS / FAIL
		CHAIN 0	CHAIN 1		
1	2412	17.62	17.62	0.5	PASS
6	2437	17.62	17.65	0.5	PASS
11	2462	17.38	17.64	0.5	PASS

802.11n (40MHz)

CHANNEL	FREQUENCY (MHz)	6dB BANDWIDTH (MHz)		MINIMUM LIMIT (MHz)	PASS / FAIL
		CHAIN 0	CHAIN 1		
3	2422	35.11	35.24	0.5	PASS
6	2437	36.13	35.83	0.5	PASS
9	2452	35.84	36.40	0.5	PASS



A D T

SPECTRUM PLOT OF WORST VALUE

802.11b

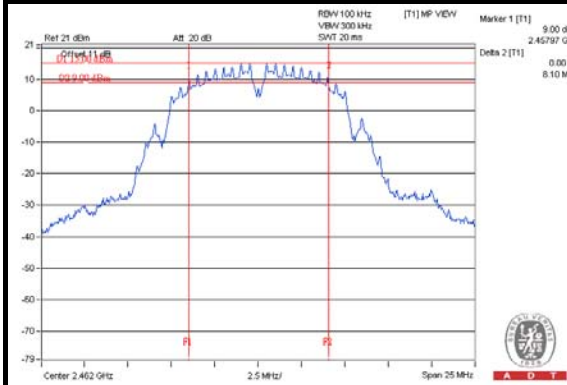

802.11g

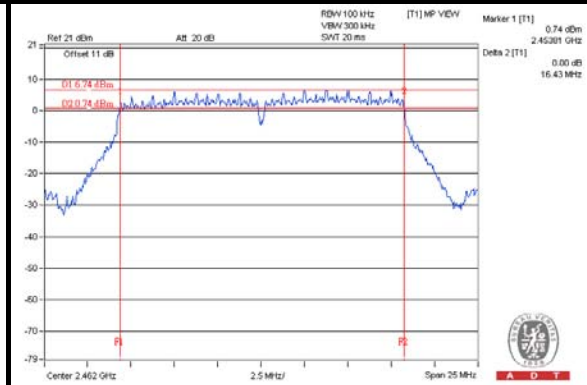

802.11n (20MHz)

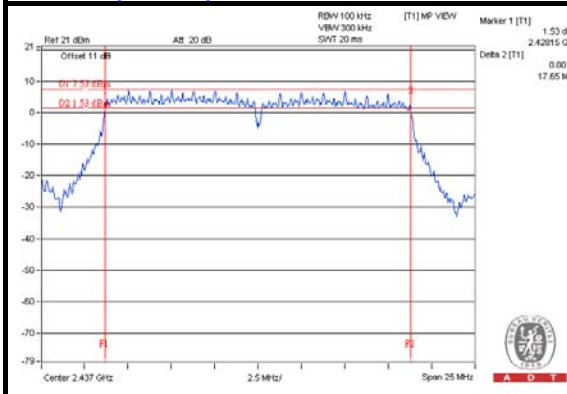

802.11n (40MHz)

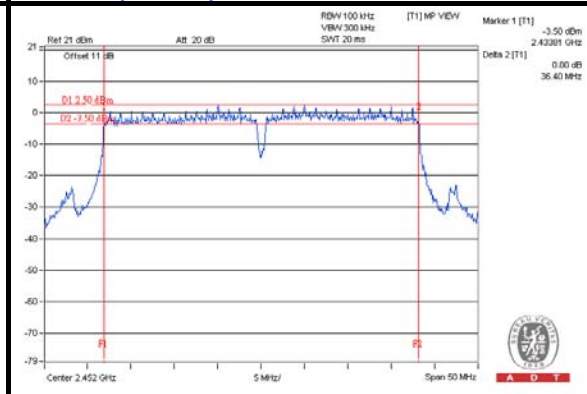

4.4 CONDUCTED OUTPUT POWER

4.4.1 LIMITS OF CONDUCTED OUTPUT POWER MEASUREMENT

For systems using digital modulation in the 2400–2483.5 MHz bands: 1 Watt (30dBm)

Per KDB 662911 D01 Multiple Transmitter Output v02r01 Method of conducted output power measurement on IEEE 802.11 devices,

Array Gain = 0 dB (i.e., no array gain) for $NANT \leq 4$;

Array Gain = 0 dB (i.e., no array gain) for channel widths ≥ 40 MHz for any NANT;

Array Gain = $5 \log(NANT/NSS)$ dB or 3 dB, whichever is less for 20-MHz channel widths with $NANT \geq 5$.

For power measurements on all other devices: Array Gain = $10 \log(NANT/NSS)$ dB.

4.4.2 TEST SETUP

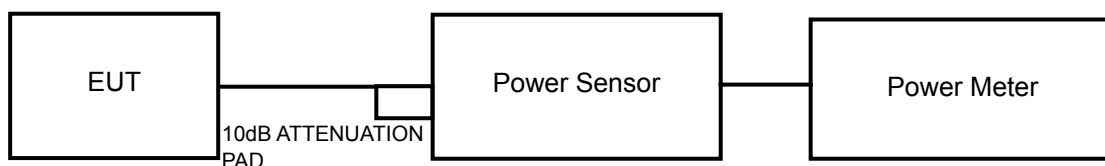

4.4.3 TEST INSTRUMENTS

Refer to section 4.1.2 to get information of above instrument.

4.4.4 TEST PROCEDURES

An average power sensor was used on the output port of the EUT. A power meter was used to read the response of the average power sensor. Record the power level.

4.4.5 DEVIATION FROM TEST STANDARD

No deviation.

4.4.6 EUT OPERATING CONDITIONS

Same as Item 4.3.6.



A D T

4.4.7 TEST RESULTS

FOR AVERAGE POWER

802.11b

CHANNEL	FREQUENCY (MHz)	AVG. POWER (mW)	AVG. POWER (dBm)	LIMIT (dBm)	PASS/FAIL
1	2412	255.859	24.08	30	PASS
6	2437	265.461	24.24	30	PASS
11	2462	202.768	23.07	30	PASS

802.11g

CHAN.	FREQ. (MHz)	AVG. POWER (dBm)		TOTAL POWER (mW)	TOTAL POWER (dBm)	LIMIT (dBm)	PASS / FAIL
		CHAIN 0	CHAIN 1				
1	2412	18.85	18.73	151.381	21.80	30	PASS
6	2437	23.98	23.81	490.471	26.91	30	PASS
11	2462	18.63	18.22	139.320	21.44	30	PASS

802.11n (20MHz)

CHAN.	FREQ. (MHz)	AVG. POWER (dBm)		TOTAL POWER (mW)	TOTAL POWER (dBm)	LIMIT (dBm)	PASS / FAIL
		CHAIN 0	CHAIN 1				
1	2412	18.65	18.53	144.567	21.60	30	PASS
6	2437	18.84	18.71	150.862	21.79	30	PASS
11	2462	18.55	18.32	139.534	21.45	30	PASS

802.11n (40MHz)

CHAN.	FREQ. (MHz)	AVG. POWER (dBm)		TOTAL POWER (mW)	TOTAL POWER (dBm)	LIMIT (dBm)	PASS / FAIL
		CHAIN 0	CHAIN 1				
3	2422	15.78	15.66	74.657	18.73	30	PASS
6	2437	18.65	19.05	153.635	21.86	30	PASS
9	2452	15.77	16.50	82.425	19.16	30	PASS

4.5 POWER SPECTRAL DENSITY MEASUREMENT

4.5.1 LIMITS OF POWER SPECTRAL DENSITY MEASUREMENT

The Maximum of Power Spectral Density Measurement is 8dBm.

4.5.2 TEST SETUP

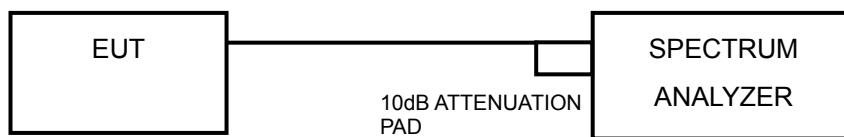

4.5.3 TEST INSTRUMENTS

Refer to section 4.1.2 to get information of above instrument.

4.5.4 TEST PROCEDURE

- Set instrument center frequency to DTS channel center frequency.
- Set span to at least 1.5 times the OBW.
- Set RBW to: $3 \text{ kHz} \leq \text{RBW} \leq 100 \text{ kHz}$.
- Set VBW $\geq 3 \times \text{RBW}$.
- Detector = power averaging (RMS) or sample detector (when RMS not available).
- Ensure that the number of measurement points in the sweep $\geq 2 \times \text{span}/\text{RBW}$.
- Sweep time = auto couple.
- Employ trace averaging (RMS) mode over a minimum of 100 traces.
- Use the peak marker function to determine the maximum amplitude level.

4.5.5 DEVIATION FROM TEST STANDARD

No deviation.

4.5.6 EUT OPERATING CONDITION

Same as Item 4.3.6

4.5.7 TEST RESULTS

802.11b

CHANNEL	FREQUENCY (MHz)	PSD W/O DUTY FACTOR (dBm)	DUTY FACTOR	PSD WITH DUTY FACTOR (dBm)	MAXIMUM LIMIT (dBm)	PASS/FAIL
1	2412	-3.91	0.71	-3.20	8	PASS
6	2437	-3.05	0.71	-2.34	8	PASS
11	2462	-4.52	0.71	-3.81	8	PASS

802.11g

TX chain	Channel	Freq. (MHz)	PSD (dBm)	10 log (N=2) dB	Total PSD (dBm)	Limit (dBm)	PASS /FAIL
0	1	2412	-11.62	3.01	-8.61	5.14	PASS
	6	2437	-6.47	3.01	-3.46	5.14	PASS
	11	2462	-11.95	3.01	-8.94	5.14	PASS
1	1	2412	-11.67	3.01	-8.66	5.14	PASS
	6	2437	-7.28	3.01	-4.27	5.14	PASS
	11	2462	-12.20	3.01	-9.19	5.14	PASS

NOTE: Directional gain = $10 \log[(10^{G1/20} + 10^{G2/20} + \dots + 10^{GN/20})/N] = 8.86\text{dBi} > 6\text{dBi}$, so the power density limit shall be reduced to $8-(8.86-6) = 5.14\text{dBm}$.

802.11n (20MHz)

TX chain	Channel	Freq. (MHz)	PSD (dBm)	10 log (N=2) dB	Total PSD (dBm)	Limit (dBm)	PASS /FAIL
0	1	2412	-12.00	3.01	-8.99	5.14	PASS
	6	2437	-11.72	3.01	-8.71	5.14	PASS
	11	2462	-12.01	3.01	-9.00	5.14	PASS
1	1	2412	-11.61	3.01	-8.60	5.14	PASS
	6	2437	-12.23	3.01	-9.22	5.14	PASS
	11	2462	-12.62	3.01	-9.61	5.14	PASS

NOTE: Directional gain = $10 \log[(10^{G1/20} + 10^{G2/20} + \dots + 10^{GN/20})/N] = 8.86\text{dBi} > 6\text{dBi}$, so the power density limit shall be reduced to $8-(8.86-6) = 5.14\text{dBm}$.

802.11n (40MHz)

TX chain	Channel	Freq. (MHz)	PSD (dBm)	10 log (N=2) dB	Duty Factor	Total PSD with Duty Factor (dBm)	Limit (dBm)	PASS /FAIL
0	3	2422	-16.89	3.01	0.13	-13.75	5.14	PASS
	6	2437	-14.87	3.01	0.13	-11.73	5.14	PASS
	9	2452	-17.10	3.01	0.13	-13.96	5.14	PASS
1	3	2422	-16.61	3.01	0.13	-13.47	5.14	PASS
	6	2437	-14.40	3.01	0.13	-11.26	5.14	PASS
	9	2452	-16.92	3.01	0.13	-13.78	5.14	PASS

NOTE: Directional gain = $10 \log[(10^{G1/20} + 10^{G2/20} + \dots + 10^{GN/20})^2/N] = 8.86\text{dBi} > 6\text{dBi}$, so the power density limit shall be reduced to $8-(8.86-6) = 5.14\text{dBm}$.

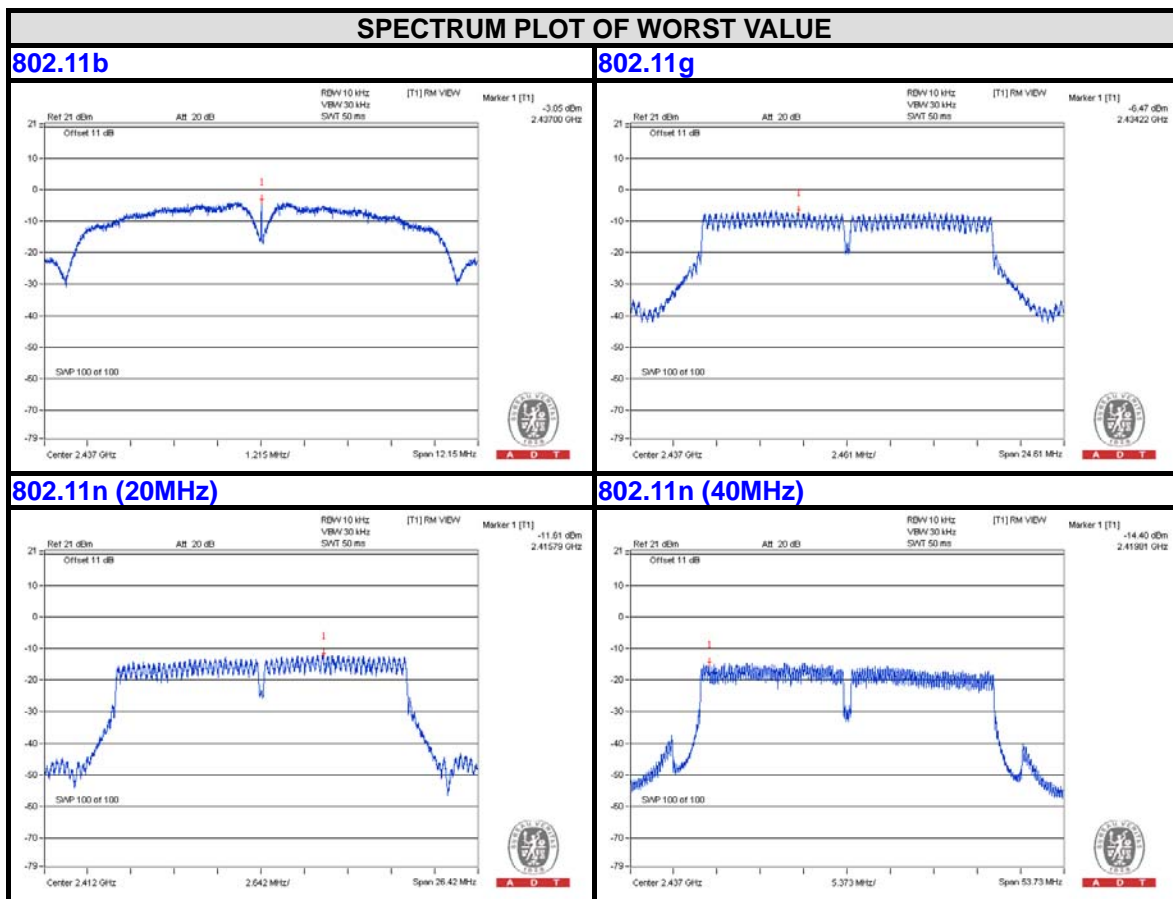

4.6 CONDUCTED OUT OF BAND EMISSION MEASUREMENT

4.6.1 LIMITS OF CONDUCTED OUT OF BAND EMISSION MEASUREMENT

Below -30dB of the highest emission level of operating band (in 100kHz Resolution Bandwidth).

4.6.2 TEST SETUP

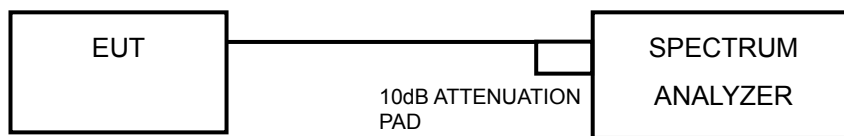

4.6.3 TEST INSTRUMENTS

Refer to section 4.1.2 to get information of above instrument.

4.6.4 TEST PROCEDURE

MEASUREMENT PROCEDURE REF

1. Set the RBW = 100 kHz.
2. Set the VBW \geq 300 kHz.
3. Detector = peak.
4. Sweep time = auto couple.
5. Trace mode = max hold.
6. Allow trace to fully stabilize.
7. Use the peak marker function to determine the maximum power level in any 100 kHz band segment within the fundamental EBW.

MEASUREMENT PROCEDURE OOB

1. Set RBW = 100 kHz.
2. Set VBW \geq 300 kHz.
3. Detector = peak.
4. Sweep = auto couple.
5. Trace Mode = max hold.
6. Allow trace to fully stabilize.
7. Use the peak marker function to determine the maximum amplitude level.

4.6.5 DEVIATION FROM TEST STANDARD

No deviation.

4.6.6 EUT OPERATING CONDITION

Same as Item 4.3.6

4.6.7 TEST RESULTS

The conducted emission test is performed on each TX port of operating mode without summing or adding 10log (N) since the limit is relative emission limit.

The spectrum plots are attached on the following pages. D1 line indicates the highest level, and D2 line indicates the 30dB offset below D1. It shows compliance with the requirement.



A D T

802.11b

CH 1

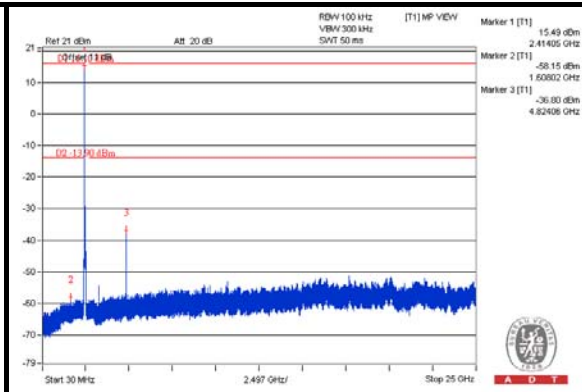
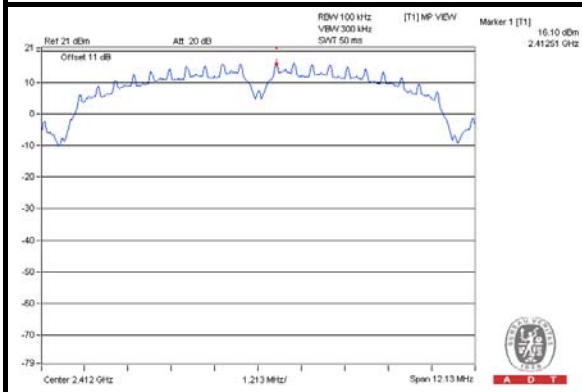

CH 6

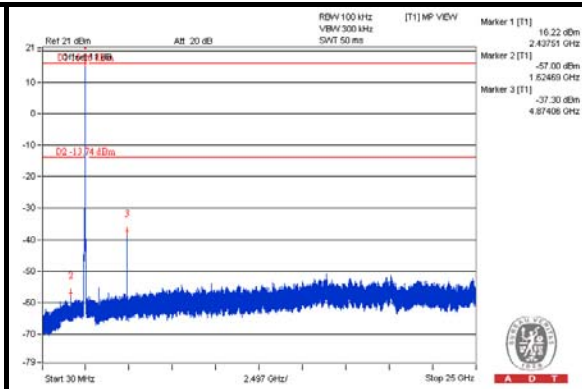
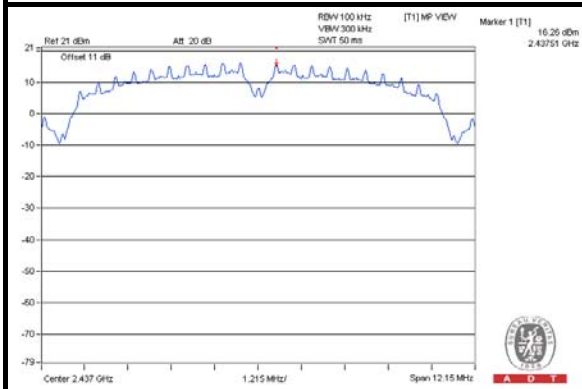

CH 11

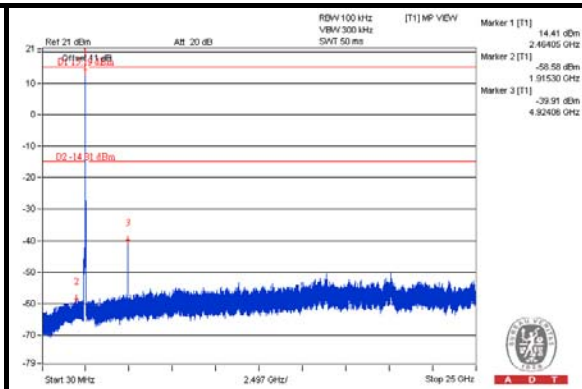
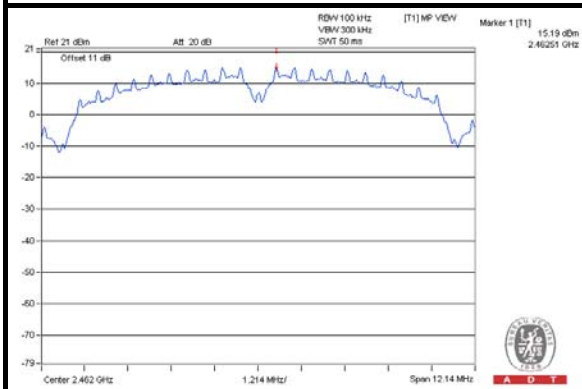

CH 1 Band edge

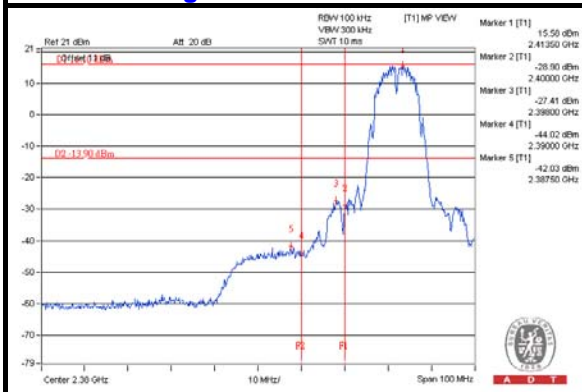

CH 11 Band edge

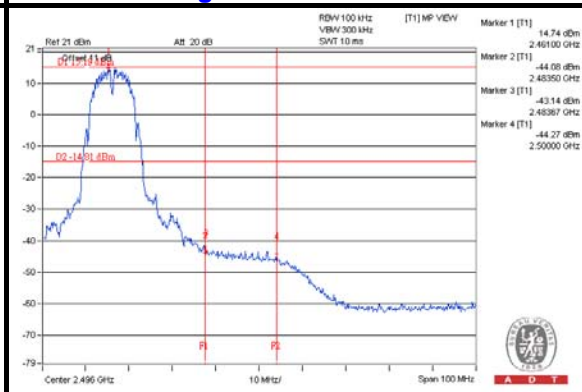



A D T

802.11g CHAIN 0

CH 1

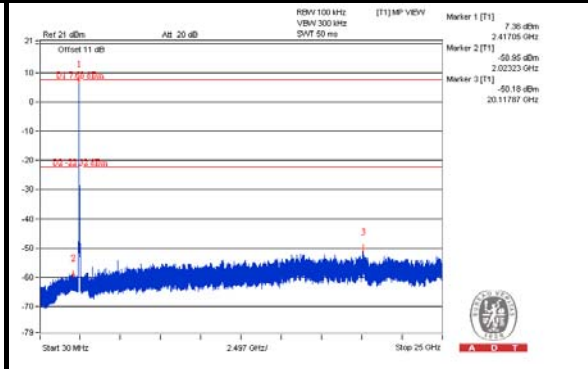
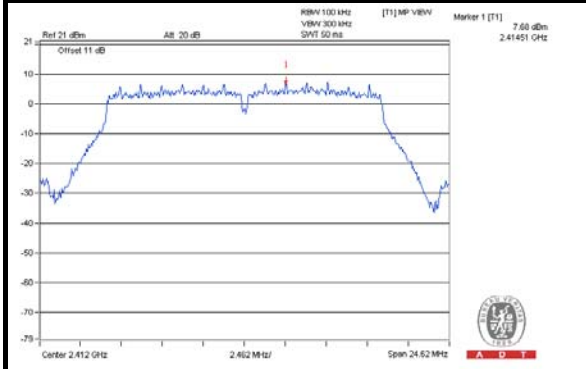

CH 6

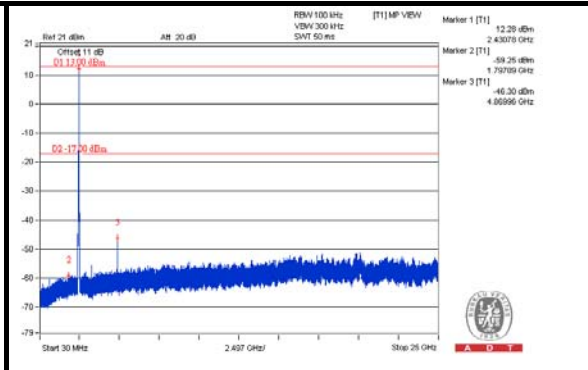
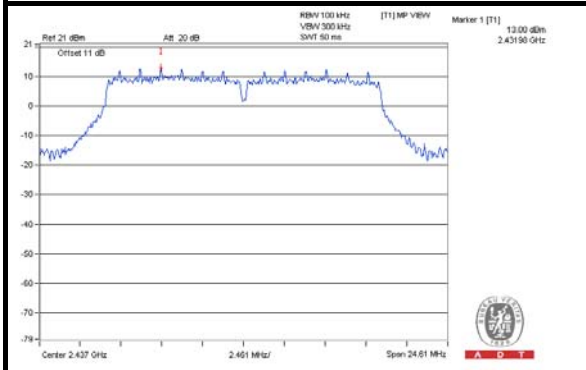

CH 11

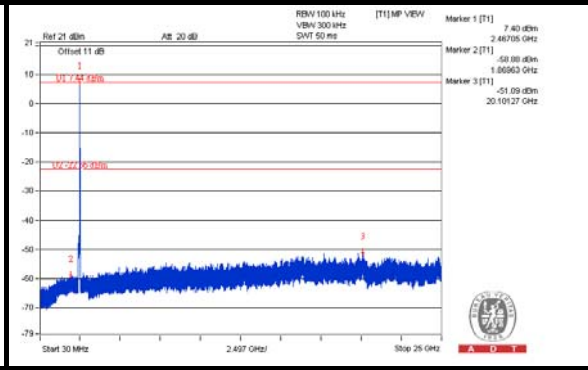
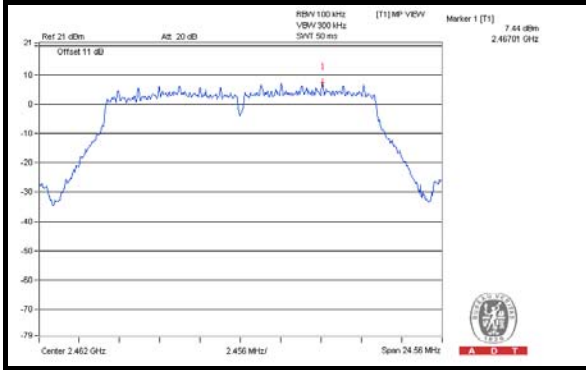

CH 1 Band edge

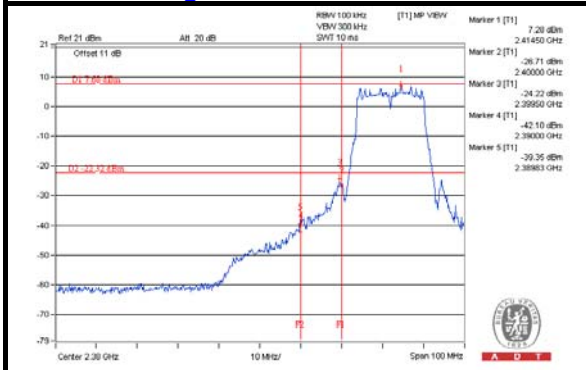

CH 11 Band edge

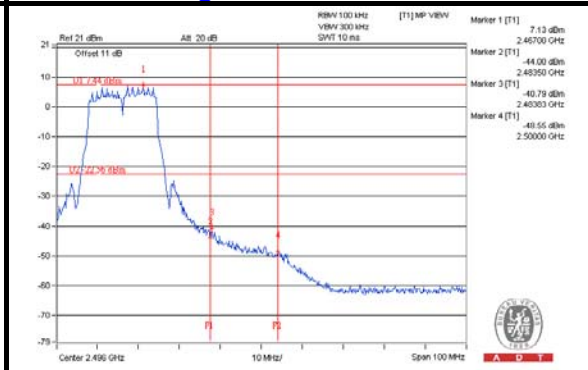



A D T

CHAIN 1

CH 1

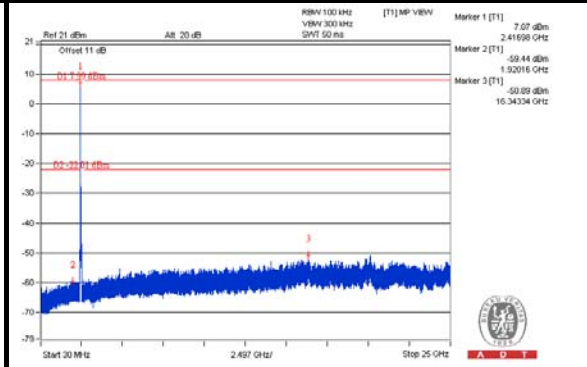
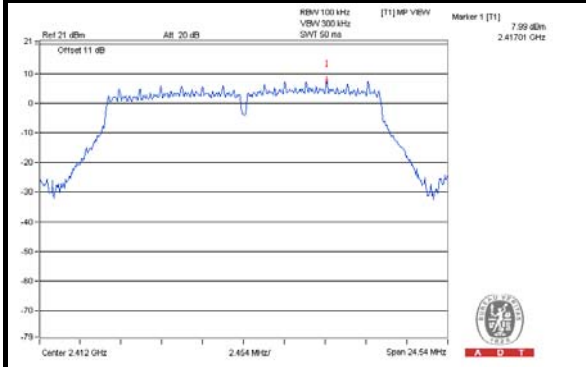

CH 6

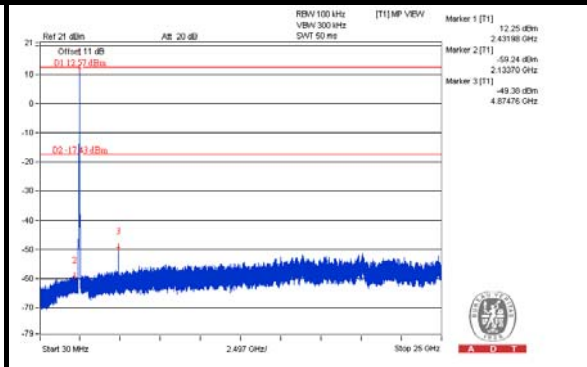
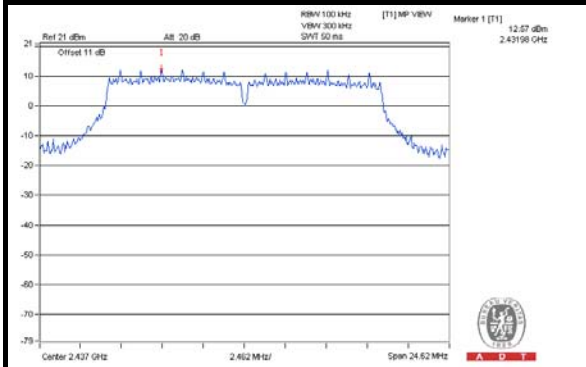

CH 11

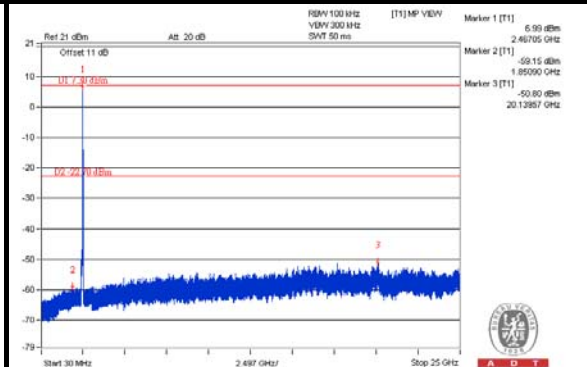
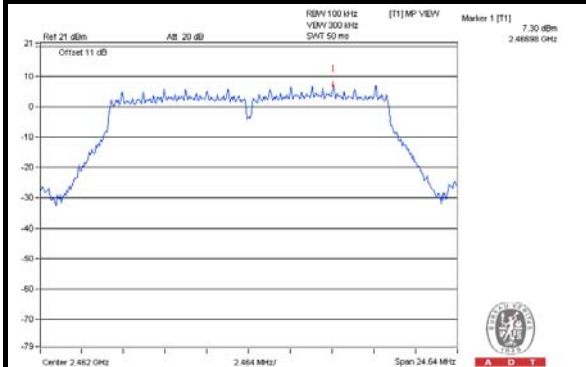

CH 1 Band edge

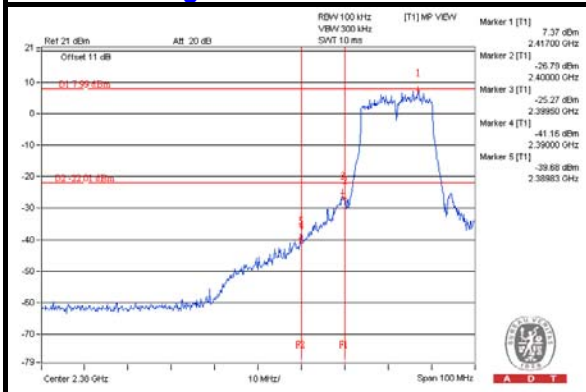

CH 11 Band edge

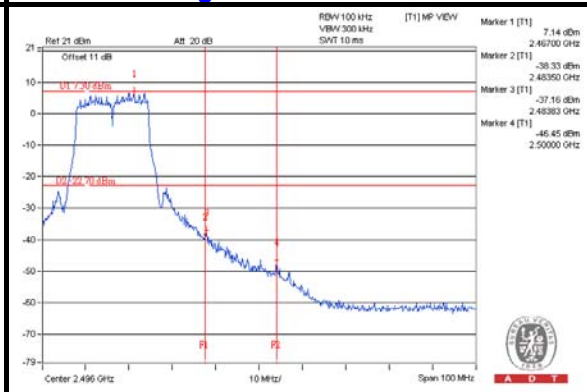



A D T

802.11n (20MHz) CHAIN 0

CH 1

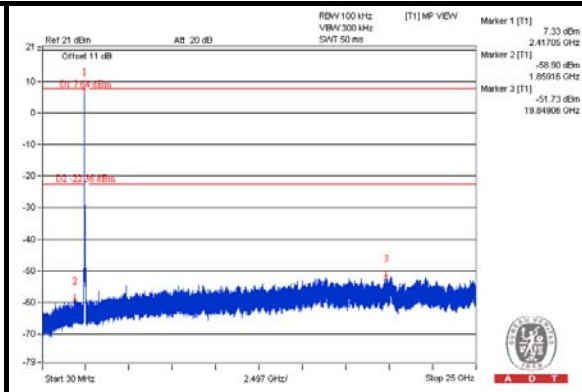
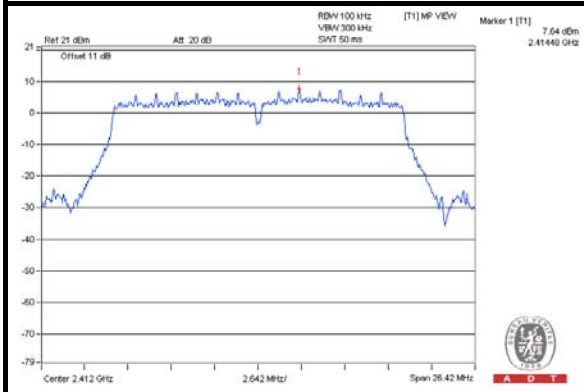

CH 6

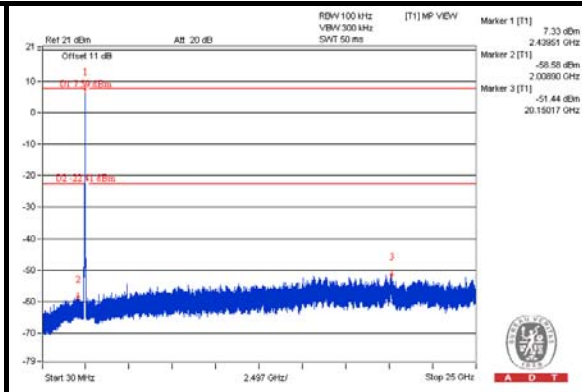
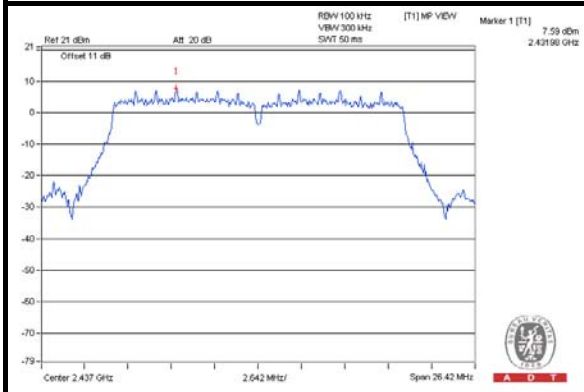

CH 11

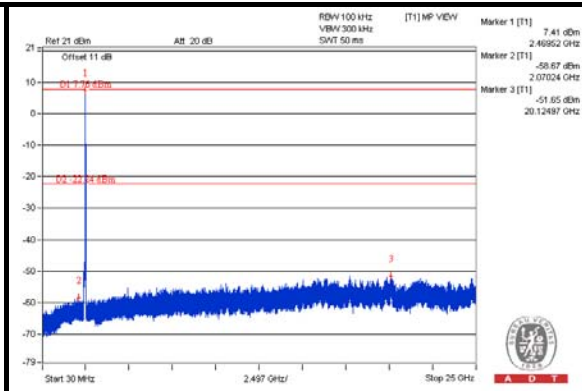
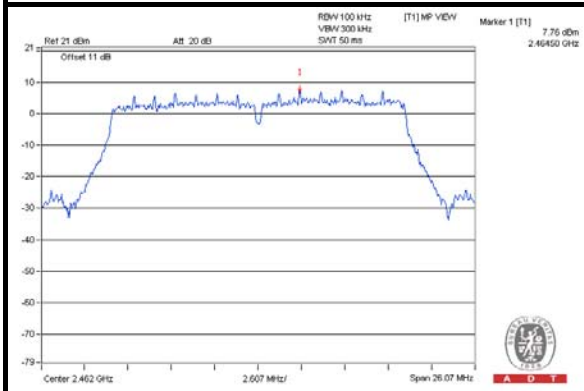

CH 1 Band edge

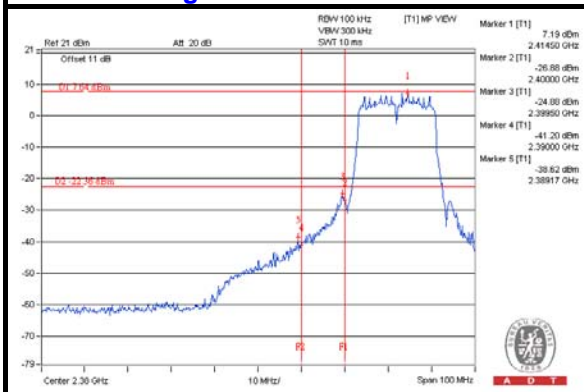

CH 11 Band edge

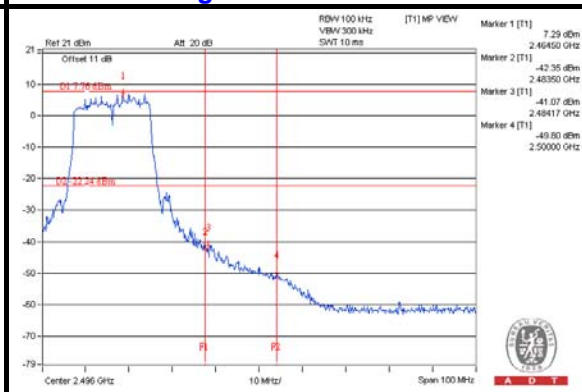



A D T

CHAIN 1

CH 1

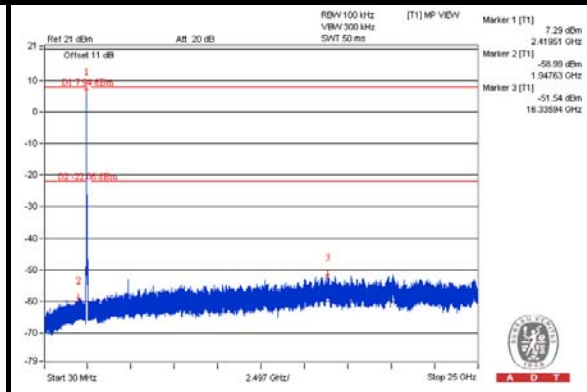
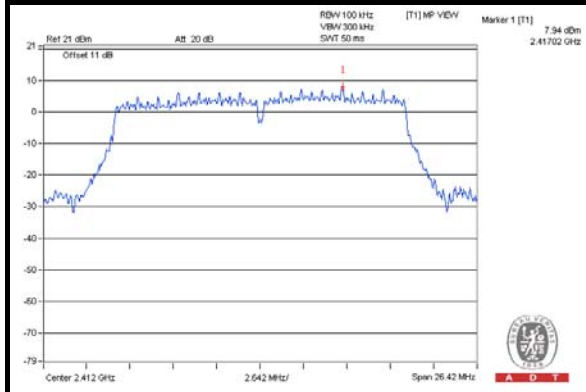

CH 6

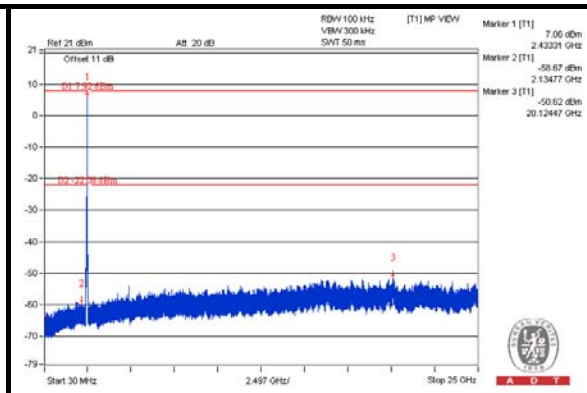
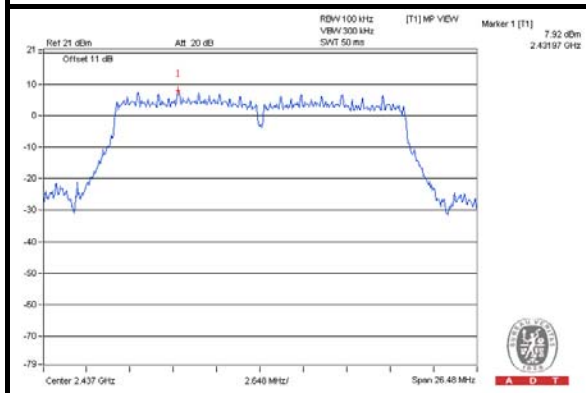

CH 11

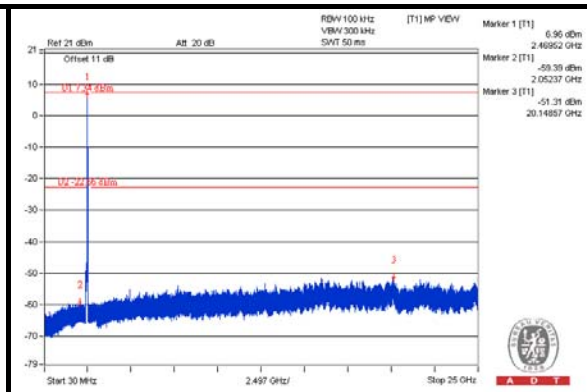
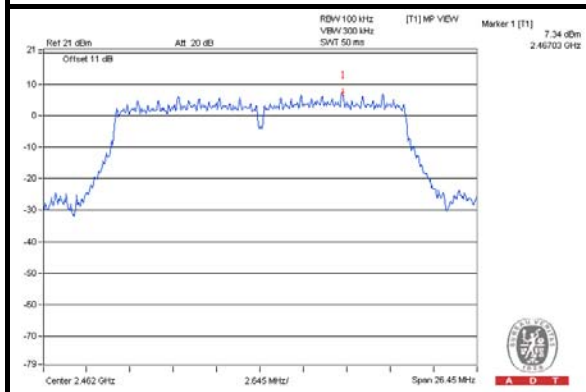

CH 1 Band edge

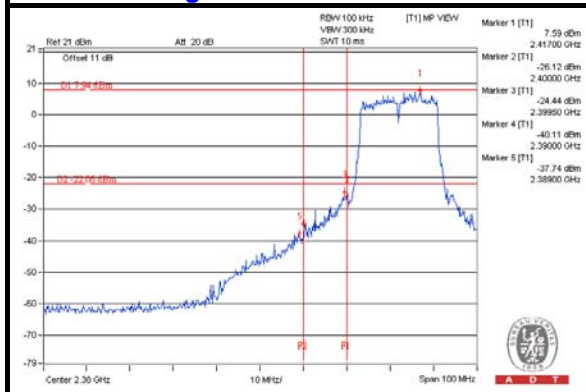

CH 11 Band edge

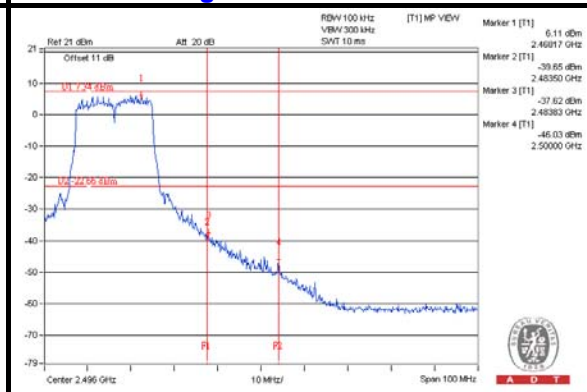



A D T

802.11n (40MHz) CHAIN 0

CH 3

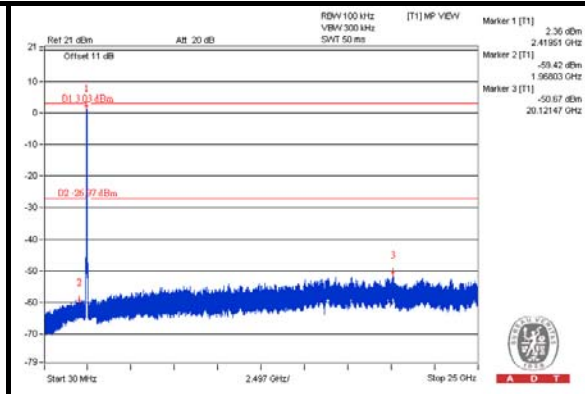
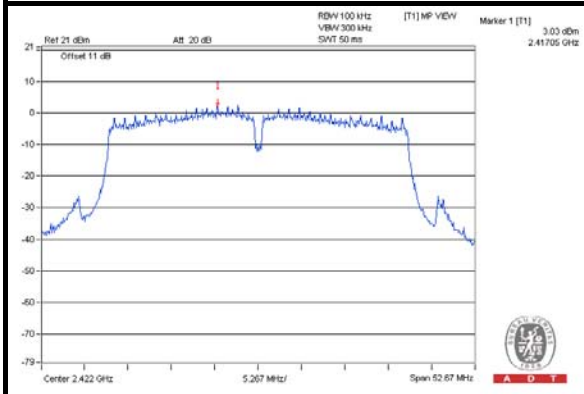

CH 6

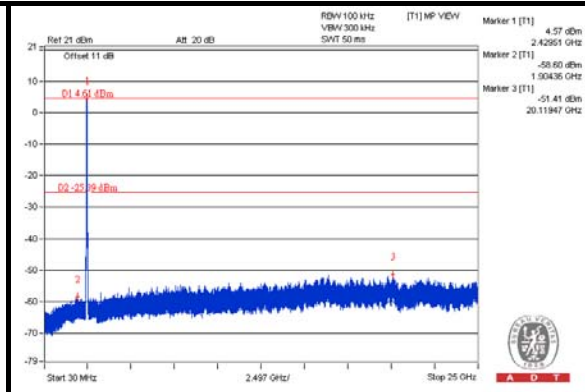
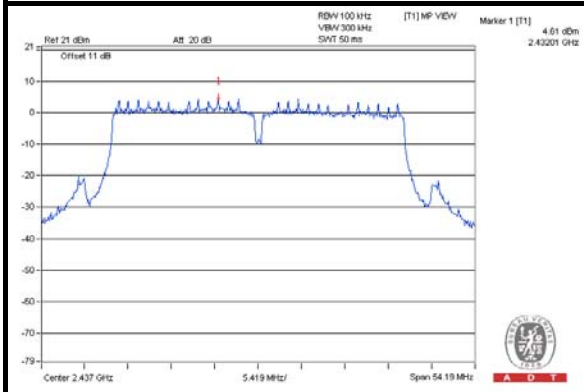

CH 9

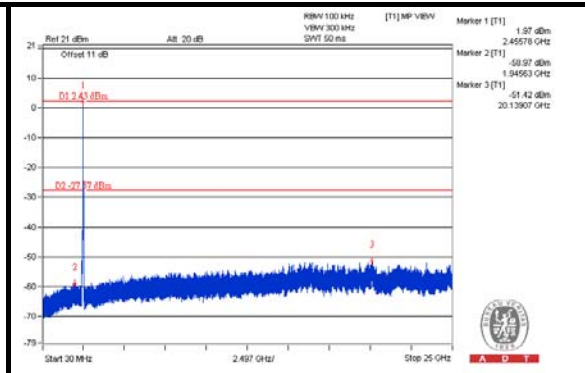
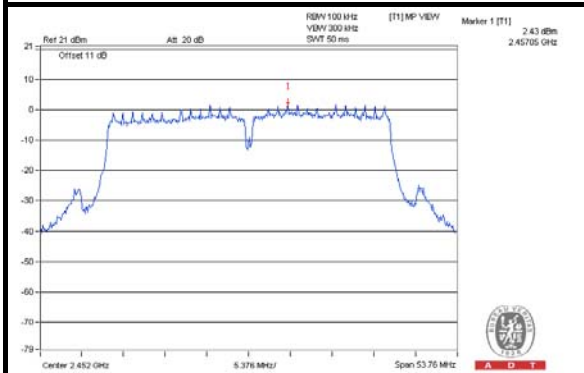

CH 3 Band edge

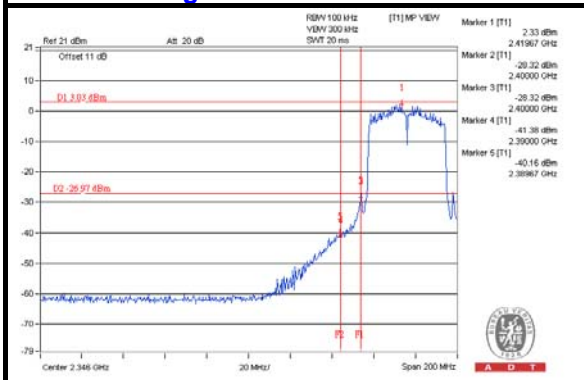

CH 9 Band edge

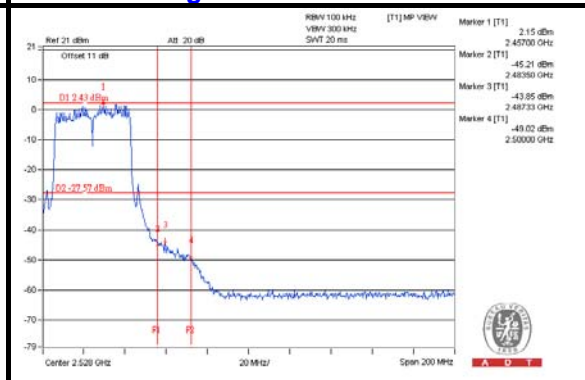



A D T

CHAIN 1

CH 3

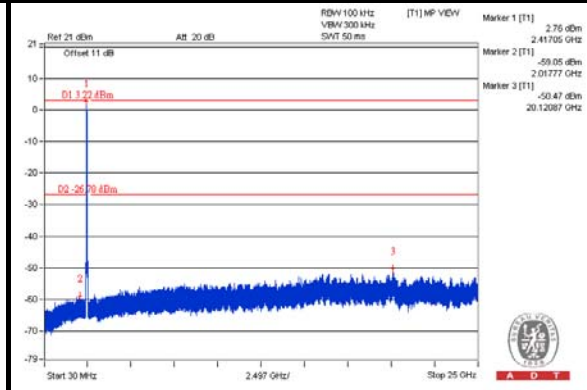
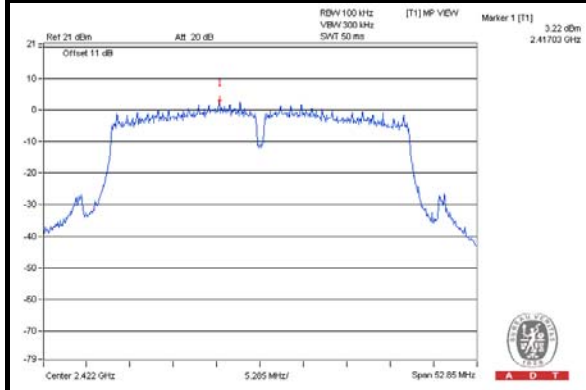

CH 6

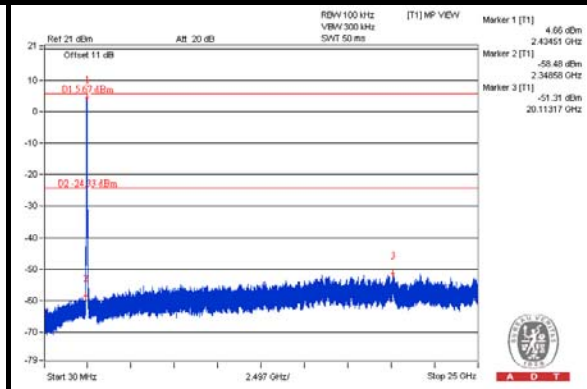
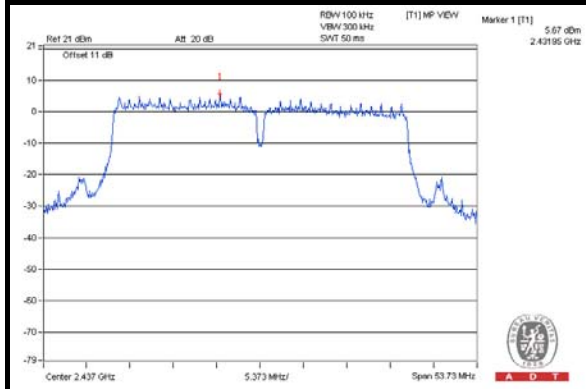

CH 9

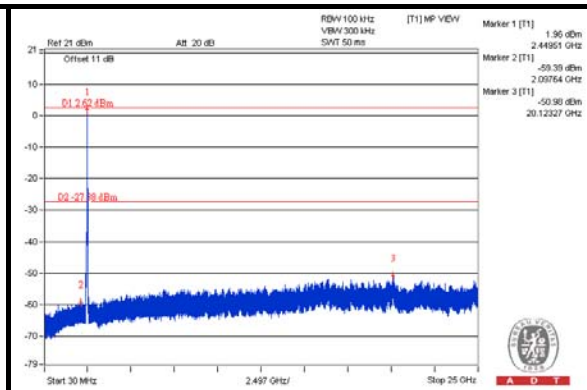
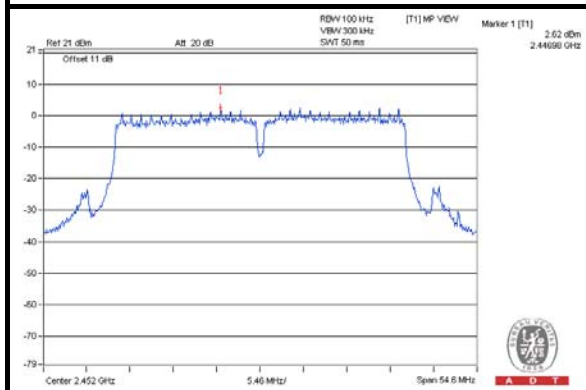

CH 3 Band edge

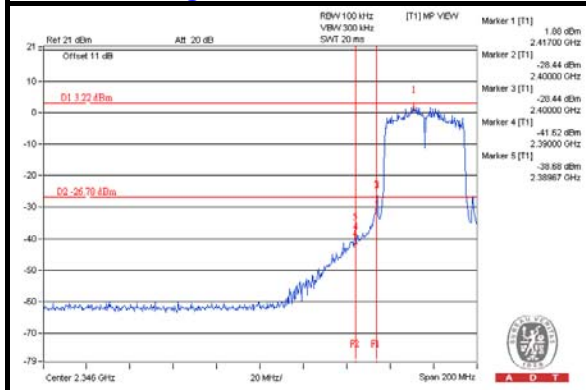

CH 9 Band edge

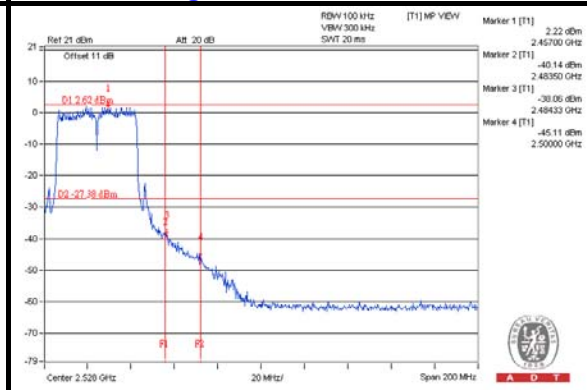

5. PHOTOGRAPHS OF THE TEST CONFIGURATION

Please refer to the attached file (Test Setup Photo).



6. INFORMATION ON THE TESTING LABORATORIES

We, Bureau Veritas Consumer Products Services (H.K.) Ltd., Taoyuan Branch, were founded in 1988 to provide our best service in EMC, Radio, Telecom and Safety consultation. Our laboratories are accredited and approved according to ISO/IEC 17025.

If you have any comments, please feel free to contact us at the following:

Linko EMC/RF Lab:

Tel: 886-2-26052180

Fax: 886-2-26051924

Hsin Chu EMC/RF/Telecom Lab:

Tel: 886-3-5935343

Fax: 886-3-5935342

Hwa Ya EMC/RF/Safety Lab:

Tel: 886-3-3183232

Fax: 886-3-3270892

Email: service.adt@tw.bureauveritas.com

Web Site: www.bureauveritas-adt.com

The address and road map of all our labs can be found in our web site also.



A D T

7. APPENDIX A – MODIFICATIONS RECORDERS FOR ENGINEERING CHANGES TO THE EUT BY THE LAB

No any modifications are made to the EUT by the lab during the test.

---END---