



# FCC TEST REPORT

**REPORT NO.:** RF960320L11

**MODEL NO.:** DUB-2240

**RECEIVED:** Mar. 20, 2007

**TESTED:** Mar. 20 ~ Apr. 17, 2007

**ISSUED:** Apr. 23, 2007

**APPLICANT:** D-Link Corporation

**ADDRESS:** 17595 Mt. Herrmann, Fountain Valley, CA  
92708, U.S.A.

**ISSUED BY:** Advance Data Technology Corporation

**LAB ADDRESS:** 47 14<sup>th</sup> Lin, Chiapau Tsun, Linko, Taipei,  
Taiwan, R.O.C.

**TEST LOCATION:** No. 19, Hwa Ya 2<sup>nd</sup> Rd., Kueishan, Taoyuan,  
Taiwan, R.O.C.

This test report consists of 46 pages in total. It may be duplicated completely for legal use with the approval of the applicant. It should not be reproduced except in full, without the written approval of our laboratory. The client should not use it to claim product endorsement by CNLA or any government agencies. The test results in the report only apply to the tested sample.





## Table of Contents

1	CERTIFICATION .....	4
2	SUMMARY OF TEST RESULTS .....	5
2.1	MEASUREMENT UNCERTAINTY .....	5
3	GENERAL INFORMATION .....	6
3.1	GENERAL DESCRIPTION OF EUT .....	6
3.2	DESCRIPTION OF TEST MODES .....	7
3.2.1	CONFIGURATION OF SYSTEM UNDER TEST .....	7
3.2.2	TEST MODE APPLICABILITY AND TESTED CHANNEL DETAIL .....	8
3.3	GENERAL DESCRIPTION OF APPLIED STANDARDS .....	10
3.4	DESCRIPTION OF SUPPORT UNITS .....	11
3.5	OPERATIONAL LIMITATIONS .....	12
4	TEST TYPES AND RESULTS .....	14
4.1	CONDUCTED EMISSION MEASUREMENT .....	14
4.1.1	LIMITS OF CONDUCTED EMISSION MEASUREMENT .....	14
4.1.2	TEST INSTRUMENTS .....	14
4.1.3	TEST PROCEDURES .....	15
4.1.4	DEVIATION FROM TEST STANDARD .....	15
4.1.5	TEST SETUP .....	16
4.1.6	EUT OPERATING CONDITIONS .....	16
4.1.7	TEST RESULTS .....	17
4.2	RADIATED EMISSION MEASUREMENT (FOR 15.517 (c)) .....	19
4.2.1	LIMITS OF RADIATED EMISSION MEASUREMENT .....	19
4.2.2	INSTRUMENT SETUP VALUE AND MEASUREMENT DISTANCE .....	20
4.2.3	TEST INSTRUMENTS .....	21
4.2.4	TEST PROCEDURES .....	22
4.2.5	DEVIATION FROM TEST STANDARD .....	22
4.2.6	TEST SETUP .....	23
4.2.7	EUT OPERATING CONDITIONS .....	23
4.2.8	TEST RESULTS .....	24
4.3	RADIATED EMISSION MEASUREMENT (FOR 15.517 (d)) .....	31
4.3.1	LIMITS OF RADIATED EMISSION MEASUREMENT .....	31
4.3.2	INSTRUMENT SETUP VALUE AND MEASUREMENT DISTANCE .....	32
4.3.3	TEST INSTRUMENTS .....	33
4.3.4	TEST PROCEDURES .....	34
4.3.5	DEVIATION FROM TEST STANDARD .....	34
4.3.6	TEST SETUP .....	35
4.3.7	EUT OPERATING CONDITIONS .....	35



4.3.8	TEST RESULTS .....	36
4.4	UWB BANDWIDTH MEASUREMENT .....	38
4.4.1	LIMITS OF UWB BANDWIDTH MEASUREMENT .....	38
4.4.2	INSTRUMENT SETUP VALUE AND MEASUREMENT DISTANCE .....	38
4.4.3	TEST INSTRUMENT .....	38
4.4.4	TEST PROCEDURE .....	38
4.4.5	DEVIATION FROM TEST STANDARD .....	38
4.4.6	TEST SETUP .....	39
4.4.7	EUT OPERATING CONDITIONS .....	39
4.4.8	TEST RESULTS .....	40
4.5	PEAK EMISSION WITHIN A 50MHZ BANDWIDTH .....	41
4.5.1	LIMITS OF PEAK EMISSION .....	41
4.5.2	INSTRUMENT SETUP VALUE AND MEASUREMENT DISTANCE .....	41
4.5.3	TEST INSTRUMENTS .....	42
4.5.4	TEST PROCEDURE .....	42
4.5.5	DEVIATION FROM TEST STANDARD .....	42
4.5.6	TEST SETUP .....	42
4.5.7	EUT OPERATING CONDITIONS .....	42
4.5.8	TEST RESULTS .....	43
4.6	ANTENNA REQUIREMENT .....	44
4.6.1	STANDARD APPLICABLE .....	44
4.6.2	ANTENNA CONNECTED CONSTRUCTION .....	44
5	INFORMATION ON THE TESTING LABORATORIES .....	45
	APPENDIX-A .....	A-1



## 2 SUMMARY OF TEST RESULTS

The EUT has been tested according to the following specifications:

APPLIED STANDARD: FCC Part 15, Subpart F			
Standard Section	Test Type and Limit	Result	REMARK
15.207	AC Power Conducted Emission	PASS	Meet the requirement of limit. Minimum passing margin is -15.96dB at 0.537MHz.
15.517(b)	UWB Bandwidth	PASS	Meet the requirement of limit.
15.209 15.517(c)	Radiated Emissions	PASS	Meet the requirement of limit. Minimum passing margin is -1.28dB at 528.01MHz..
15.209 15.517(d)	Radiated Emissions in GPS Band	PASS	Meet the requirement of limit. Minimum passing margin is -20.84dB at 1584.00MHz..
15.517(e)	Peak Emissions within a 50MHz Bandwidth	PASS	Meet the requirement of limit. Minimum passing margin is -1.79dB at 4492.00MHz.

### 2.1 MEASUREMENT UNCERTAINTY

Where relevant, the following measurement uncertainty levels have been estimated for tests performed on the EUT as specified in CISPR 16-4:

MEASUREMENT	FREQUENCY	UNCERTAINTY
Conducted emissions	9kHz~30MHz	2.44 dB
Radiated emissions	30MHz ~ 200MHz	3.71 dB
	200MHz ~ 1000MHz	3.73 dB
	1GHz ~ 18GHz	2.26 dB
	18GHz ~ 40GHz	1.94 dB

This uncertainty represents an expanded uncertainty expressed at approximately the 95% confidence level using a coverage factor of k=2.

### 3 GENERAL INFORMATION

#### 3.1 GENERAL DESCRIPTION OF EUT

<b>PRODUCT</b>	UWB D-Link HUB DUB-2240 A1
<b>MODEL NO.</b>	DUB-2240
<b>FCC ID</b>	KA2UB2240A1
<b>POWER SUPPLY</b>	5.0Vdc from AC adapter
<b>MODULATION TECHNOLOGY</b>	MOFDM
<b>FREQUENCY RANGE</b>	3.1 to 4.8GHz (Supporting up to 3 MBOA sub-bands, 528MHz each)
<b>MAXIMUM OUTPUT POWER</b>	-26.23dBm (68.97 dBuV/m)
<b>ANTENNA TYPE</b>	Metal antenna with 2dBi gain
<b>I/O PORTS</b>	USB
<b>DATA CABLE</b>	1m shielded USB cable without core
<b>ASSOCIATED DEVICES</b>	Adapter

**NOTE:**

1. The EUT was powered by the following adapter:

<b>Brand:</b>	JENTEC TECHNOLOGY CO., LTD.
<b>Model:</b>	AF1805-A
<b>Input:</b>	100-120Vac, 50-60Hz, 0.4A
<b>Output:</b>	5Vdc, 3A
<b>Power line:</b>	1.8m non-shielded cable without core

2. The above EUT information was declared by manufacturer and for more detailed features description, please refer to the manufacturer's specifications or User's Manual.

### 3.2 DESCRIPTION OF TEST MODES

Four transmission modes are provided to this EUT.

MODE	SUB-BAND	FREQUENCY (MHZ)
1	1	3432
2	2	3960
3	3	4488
4	1, 2, 3	3432, 3960, 4488

**NOTE:** After pre-testing each mode, the combination mode (sub-band 1, 2, 3) was the worst situation and only the data was presented in the following sections.

#### 3.2.1 CONFIGURATION OF SYSTEM UNDER TEST

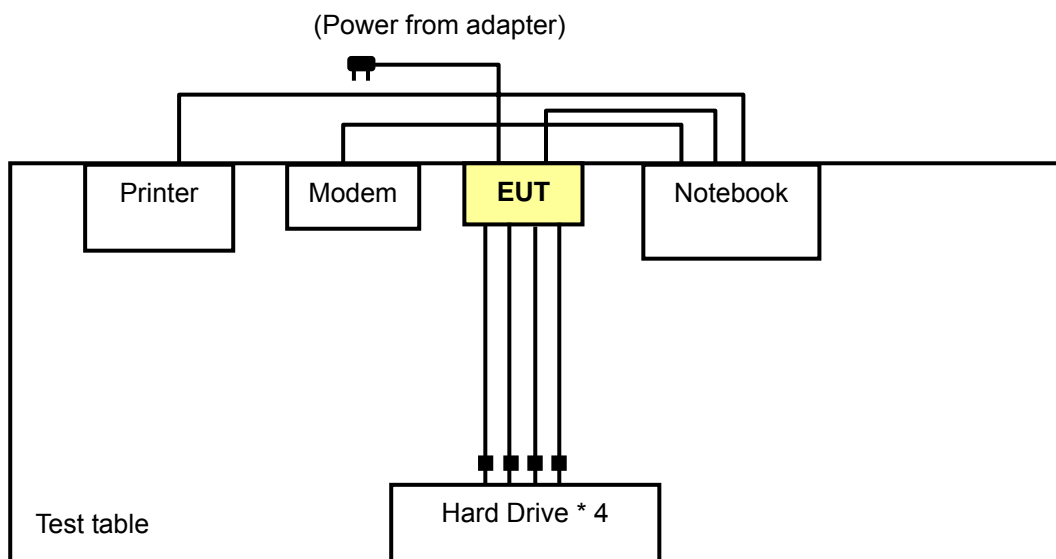

### 3.2.2 TEST MODE APPLICABILITY AND TESTED CHANNEL DETAIL

EUT configure mode	Applicable to					Description
	PLC	RE<1G	RE≥1G	UB	PE	
-	√	√	√	√	√	Sub-band 1, 2, 3

Where **PLC**: Power Line Conducted Emission      **RE<1G**: Radiated Emission below 1GHz  
**RE≥1G**: Radiated Emission above 1GHz      **UB**:UBW Bandwidth  
**PE**: Peak Emission

#### **POWER LINE CONDUCTED EMISSION TEST:**

- Pre-Scan has been conducted to determine the worst-case mode from all possible combinations between available modulations, data rates and antenna ports (if EUT with antenna diversity architecture).
- Following channel(s) was (were) selected for the final test as listed below.

EUT configure mode	Available Sub-band	Tested Sub-band	Modulation Technology
-	1 to 3	1, 2, 3	MOFDM

#### **RADIATED EMISSION TEST (BELOW 960 MHz):**

- Pre-Scan has been conducted to determine the worst-case mode from all possible combinations between available modulations, data rates and antenna ports (if EUT with antenna diversity architecture).
- Following channel(s) was (were) selected for the final test as listed below.

EUT configure mode	Available Sub-band	Tested Sub-band	Modulation Technology
-	1 to 3	1, 2, 3	MOFDM



**RADIATED EMISSION TEST (ABOVE 960 MHz):**

- Pre-Scan has been conducted to determine the worst-case mode from all possible combinations between available modulations, data rates and antenna ports (if EUT with antenna diversity architecture).
- Following channel(s) was (were) selected for the final test as listed below.

EUT configure mode	Available Sub-band	Tested Sub-band	Modulation Technology
-	1 to 3	1, 2, 3	MOFDM

**UWB BANDWIDTH MEASUREMENT:**

- Pre-Scan has been conducted to determine the worst-case mode from all possible combinations between available modulations, data rates and antenna ports (if EUT with antenna diversity architecture).
- Following channel(s) was (were) selected for the final test as listed below.

EUT configure mode	Available Sub-band	Tested Sub-band	Modulation Technology
-	1 to 3	1, 2, 3	MOFDM

**PEAK EMISSION MEASUREMENT**

- Pre-Scan has been conducted to determine the worst-case mode from all possible combinations between available modulations, data rates and antenna ports (if EUT with antenna diversity architecture).
- Following channel(s) was (were) selected for the final test as listed below.

EUT configure mode	Available Sub-band	Tested Sub-band	Modulation Technology
-	1 to 3	1, 2, 3	MOFDM



### **3.3 GENERAL DESCRIPTION OF APPLIED STANDARDS**

The EUT is a UWB product. According to the specifications of the manufacturer, it must comply with the requirements of the following standards:

**FCC Part 15, Subpart F. (15.517)**

**ANSI C63.4-2003**

#### **THE EVOLUTION OF MODERN UWB TECHNOLOGY**

All test items have been performed and recorded as per the above standards.

**NOTE:** The EUT is also considered as a kind of computer peripheral, because the connection to computer is necessary for typical use. It has been verified to comply with the requirements of FCC Part 15, Subpart B, Class B (DoC). The test report has been issued separately.



### 3.4 DESCRIPTION OF SUPPORT UNITS

The EUT has been tested as an independent unit together with other necessary accessories or support units. The following support units or accessories were used to form a representative test configuration during the tests.

NO.	PRODUCT	BRAND	MODEL NO.	SERIAL NO.	FCC ID
1	NOTEBOOK COMPUTER	DELL	PP05L	9954115984	E2K24CLNS
2	MODEM	ACEEX	1414V/3	0401008248	IFAXDM1414
3	PRINTER	EPSON	LQ-300+	DCGY046781	FCC DoC Approved
4	FIREWIRE HARD DRIVE	Terasys	F12-UF	A0100222-4860019	FCC DoC Approved
5	FIREWIRE HARD DRIVE	Terasys	F12-UF	A0100222-5390018	FCC DoC Approved
6	FIREWIRE HARD DRIVE	Terasys	F12-UF	A0100222-35G0014	FCC DoC Approved
7	FIREWIRE HARD DRIVE	Terasys	F12-UF	A0100222-4A71004	FCC DoC Approved

NO.	SIGNAL CABLE DESCRIPTION OF THE ABOVE SUPPORT UNITS
1	1m shielded cable
2	1.8m shielded cable
3	1.2m shielded cable
4	1.6m shielded cable
5	1.6m shielded cable
6	1.6m shielded cable
7	1.6m shielded cable

**NOTE:** All power cords of the above support units are non-shielded (1.8m).



### 3.5 OPEARTIONAL LIMIATIONS

#### FCC 47 CFR Section 15.517(a)(1)

- (1) Indoor UWB devices, by the nature of their design, must be capable of operation only indoors. The necessity to operate with a fixed indoor infrastructure, *e.g.*, a transmitter that must be connected to the AC power lines, may be considered sufficient to demonstrate this.

EUT connected to the AC power lines.

#### FCC 47 CFR Section 15.517(a)(2)

- (2) The emissions from equipment operated under this section shall not be intentionally directed outside of the building in which the equipment is located, such as through a window or a doorway, to perform an outside function, such as the detection of persons about to enter a building.

Client has been advised

#### FCC 47 CFR Section 15.517(a)(3)

- (3) The use of outdoor mounted antennas, *e.g.*, antennas mounted on the outside of a building or on a telephone pole, or any other outdoors infrastructure is prohibited.

Client has been advised



FCC 47 CFR Section 15.517(a)(4)

- (4) Field disturbance sensors installed inside of metal or underground storage tanks are considered to operate indoors provided the emissions are directed towards the ground.

EUT is not a Field disturbance sensor

FCC 47 CFR Section 15.517(a)(5)

- (5) A communications system shall transmit only when the intentional radiator is sending information to an associated receive

Client has been advised and showed on users manual

## 4 TEST TYPES AND RESULTS

### 4.1 CONDUCTED EMISSION MEASUREMENT

#### 4.1.1 LIMITS OF CONDUCTED EMISSION MEASUREMENT

FREQUENCY OF EMISSION (MHz)	CONDUCTED LIMIT (dB $\mu$ V)	
	Quasi-peak	Average
0.15-0.5	66 to 56	56 to 46
0.5-5	56	46
5-30	60	50

- NOTE:**
1. The lower limit shall apply at the transition frequencies.
  2. The limit decreases in line with the logarithm of the frequency in the range of 0.15 to 0.50 MHz.
  3. All emanations from a class A/B digital device or system, including any network of conductors and apparatus connected thereto, shall not exceed the level of field strengths specified above.

#### 4.1.2 TEST INSTRUMENTS

DESCRIPTION & MANUFACTURER	MODEL NO.	SERIAL NO.	CALIBRATED UNTIL
Test Receiver ROHDE & SCHWARZ	ESCS30	100288	Sep. 25, 2007
RF signal cable Woken	5D-FB	Cable-HYCO3-01	Jan. 06, 2008
LISN ROHDE & SCHWARZ	ESH2-Z5	100100	Jan. 08, 2008
LISN ROHDE & SCHWARZ	ESH3-Z5	100311	Jan. 16, 2008
Software ADT	ADT_Cond_V3	NA	NA

- NOTE:**
1. The calibration interval of the above test instruments is 12 months and the calibrations are traceable to NML/ROC and NIST/USA.
  2. The test was performed in HwaYa Shielded Room 2.
  3. The VCCI Site Registration No. is C-2047.



#### 4.1.3 TEST PROCEDURES

- a. The EUT was placed 0.4 meters from the conducting wall of the shielded room with EUT being connected to the power mains through a line impedance stabilization network (LISN). Other support units were connected to the power mains through another LISN. The two LISNs provide 50 ohm/ 50uH of coupling impedance for the measuring instrument.
- b. Both lines of the power mains connected to the EUT were checked for maximum conducted interference.
- c. The frequency range from 150kHz to 30MHz was searched. Emission levels under Limit - 20dB was not recorded.

#### 4.1.4 DEVIATION FROM TEST STANDARD

No deviation

#### 4.1.5 TEST SETUP

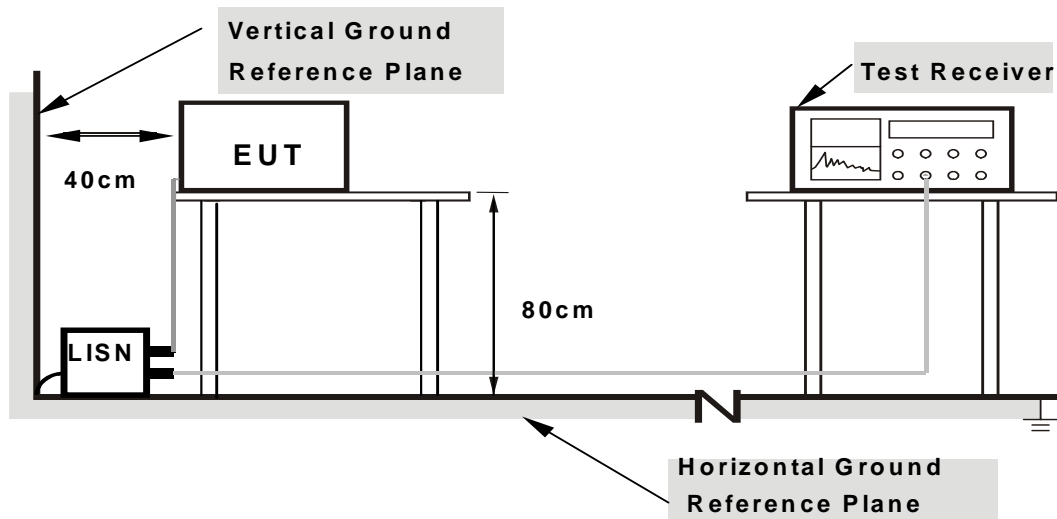

- Note:**
- 1.Support units were connected to second LISN.
  - 2.Both of LISNs (AMN) are 80 cm from EUT and at least 80 from other units and other metal planes

For the actual test configuration, please refer to the attached file (Test Setup Photo).

#### 4.1.6 EUT OPERATING CONDITIONS

- a. Connected the EUT to HDDs and placed on a testing table.
- b. The EUT read/write data from the USB HDDs.
- c. Set the EUT under transmission condition continuously at specific channel frequency.
- d. The necessary accessories enable the system in full functions.

#### 4.1.7 TEST RESULTS

##### CONDUCTED WORST-CASE DATA

EUT TEST CONDITION		MEASUREMENT DETAIL	
SUB-BAND	1, 2, 3	PHASE	Line 1
MODULATION TECHNOLOGY	MOFDM	6dB BANDWIDTH	9 kHz
ENVIRONMENTAL CONDITIONS	20deg. C, 60%RH, 991hPa	INPUT POWER (SYSTEM)	120Vac, 60 Hz
TESTED BY	Lori Chiu		

No	Freq. [MHz]	Corr.	Reading Value		Emission Level		Limit		Margin	
		Factor	[dB (uV)]		[dB (uV)]		[dB (uV)]		(dB)	
		(dB)	Q.P.	AV.	Q.P.	AV.	Q.P.	AV.	Q.P.	AV.
1	0.166	0.10	39.71	-	39.81	-	65.18	55.18	-25.37	-
2	0.185	0.10	37.20	-	37.30	-	64.25	54.25	-26.95	-
3	0.537	0.10	39.24	-	39.34	-	56.00	46.00	-16.66	-
4	2.680	0.24	28.48	-	28.72	-	56.00	46.00	-27.28	-
5	9.477	0.33	19.37	-	19.70	-	60.00	50.00	-40.30	-
6	29.922	1.23	22.60	-	23.83	-	60.00	50.00	-36.17	-

- REMARKS:**
1. Q.P. and AV. are abbreviations of quasi-peak and average individually.
  2. "-": The Quasi-peak reading value also meets average limit and measurement with the average detector is unnecessary.
  3. The emission levels of other frequencies were very low against the limit.
  4. Margin value = Emission level - Limit value
  5. Correction factor = Insertion loss + Cable loss
  6. Emission Level = Correction Factor + Reading Value.

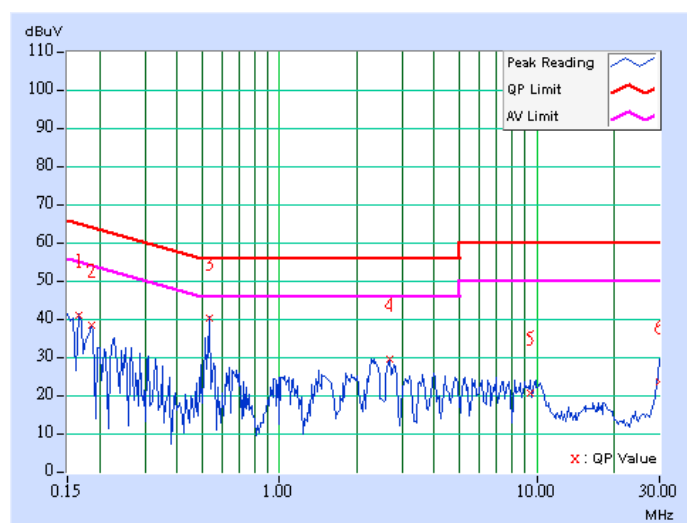

EUT TEST CONDITION		MEASUREMENT DETAIL	
SUB-BAND	1, 2, 3	PHASE	Line 2
MODULATION TECHNOLOGY	MOFDM	6dB BANDWIDTH	9 kHz
ENVIRONMENTAL CONDITIONS	20deg. C, 60%RH, 991hPa	INPUT POWER (SYSTEM)	120Vac, 60 Hz
TESTED BY	Lori Chiu		

No	Freq. [MHz]	Corr.	Reading Value		Emission Level		Limit		Margin	
		Factor	[dB (uV)]		[dB (uV)]		[dB (uV)]		(dB)	
		(dB)	Q.P.	AV.	Q.P.	AV.	Q.P.	AV.	Q.P.	AV.
1	0.166	0.10	44.01	-	44.11	-	65.18	55.18	-21.07	-
2	0.205	0.10	38.42	-	38.52	-	63.42	53.42	-24.90	-
3	<b>0.537</b>	<b>0.13</b>	<b>39.91</b>	-	<b>40.04</b>	-	<b>56.00</b>	<b>46.00</b>	<b>-15.96</b>	-
4	2.719	0.24	29.59	-	29.83	-	56.00	46.00	-26.17	-
5	9.883	0.43	20.75	-	21.18	-	60.00	50.00	-38.82	-
6	29.973	0.94	25.46	-	26.40	-	60.00	50.00	-33.60	-

- REMARKS:**
1. Q.P. and AV. are abbreviations of quasi-peak and average individually.
  2. "-": The Quasi-peak reading value also meets average limit and measurement with the average detector is unnecessary.
  3. The emission levels of other frequencies were very low against the limit.
  4. Margin value = Emission level - Limit value
  5. Correction factor = Insertion loss + Cable loss
  6. Emission Level = Correction Factor + Reading Value.

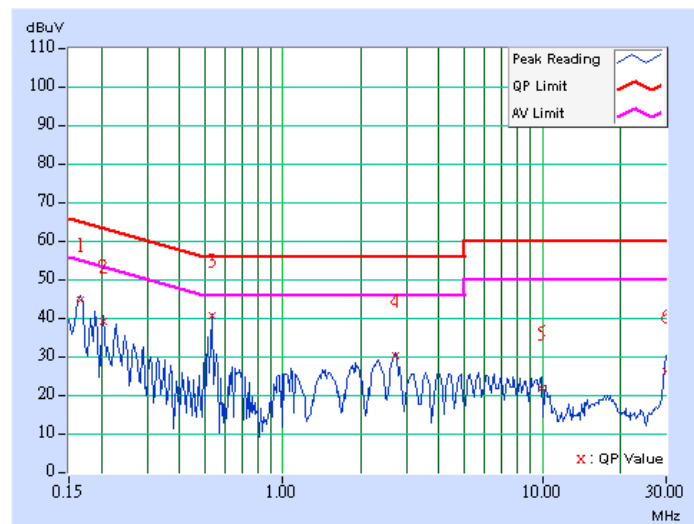

## 4.2 RADIATED EMISSION MEASUREMENT (FOR 15.517 (c))

### 4.2.1 LIMITS OF RADIATED EMISSION MEASUREMENT

The radiated emissions at or below 960MHz from a device operating under the provisions of this section shall not exceed the emission levels in Section 15.209.

FREQUENCIES (MHz)	FIELD STRENGTH (mV/m)	MEASUREMENT DISTANCE (m)
0.009 ~ 0.490	2400/F(kHz)	300
0.490 ~ 1.705	24000/F(kHz)	30
1.705 ~ 30.0	30	30
30 ~ 88	100	3
88 ~ 216	150	3
216 ~ 960	200	3

**NOTE:** 1. The lower limit shall apply at the transition frequencies.

2. Emission level (dBuV/m) = 20 log Emission level (uV/m).

The radiated emissions above 960MHz from a device operating under the provisions of this section shall not exceed the following average limits when measured using a resolution bandwidth of 1MHz:

FREQUENCY IN MHz	EIRP IN dBm	dBuV/m@3m	dBuV/m@1m
960 ~ 1,610	-75.3	19.9	29.44
1,610 ~ 1,990	-53.3	41.9	51.44
1,990 ~ 3,100	-51.3	43.9	53.44
3,100 ~ 10,600	-41.3	53.9	63.44
Above 10600	-51.3	43.9	53.44

Transfer rules follow 15.521(g),15.31(f)(1).

15.521(c) Emissions from digital circuitry used to enable the operation of the UWB transmitter shall comply with the limits in Section 15.209 of this chapter, rather than the limits specified in this subpart.

**NOTE:** Use conducted measurement to determine emissions is from digital circuitry or not.  
Emissions from digital circuitry follow 15.209 else 15.517

The radiated emissions from a device operating under the provisions of this section shall not exceed the emission levels in Section 15.209.

FREQUENCY IN MHz	dBuV/m@3m	dBuV/m@1m
	Quasi Peak	Quasi Peak
216 ~ 960	46.00	55.54
960 ~ 1000	54.00	63.54

FREQUENCY IN MHz	dBuV/m@3m		dBuV/m@1m	
Above 1000	Peak	Average	Peak	Average
	74.00	54.00	83.54	63.54

#### 4.2.2 INSTRUMENT SETUP VALUE AND MEASUREMENT DISTANCE

FREQUENCY RANGE	RESOLUTION BANDWIDTH	VIDEO BANDWIDTH	DETECTOR	MEASUREMENT DISTANCE
Below 960MHz	120kHz	120kHz	Quasi Peak	3 meters
Above 960MHz	1MHz	3MHz	RMS	1 meter



### 4.2.3 TEST INSTRUMENTS

DESCRIPTION & MANUFACTURER	MODEL NO.	SERIAL NO.	CALIBRATED UNTIL
Test Receiver ROHDE & SCHWARZ	ESI7	100033	May 22, 2007
Spectrum Analyzer ROHDE & SCHWARZ	FSP40	100025	Oct. 05, 2007
BILOG Antenna SCHWARZBECK	VULB9168	9168-160	May 31, 2007
HORN Antenna SCHWARZBECK	9120D	9120D-209	Jun. 27, 2007
HORN Antenna SCHWARZBECK	BBHA 9170	BBHA9170243	Dec. 28, 2007
Preamplifier Agilent	8447D	2944A10633	Oct. 26, 2007
Preamplifier Agilent	8449B	3008A01964	Oct. 26, 2007
RF signal cable HUBER+SUHNNER	SUCOFLEX 104	238137/4	Dec. 11, 2007
RF signal cable HUBER+SUHNNER	SUCOFLEX 104	233233/4	Nov. 14, 2007
Software ADT.	ADT_Radiated_V7.6	NA	NA
Antenna Tower inn-co GmbH	MA 4000	013303	NA
Antenna Tower Controller inn-co GmbH	CO2000	017303	NA
Turn Table ADT.	TT100.	TT93021703	NA
Turn Table Controller ADT.	SC100.	SC93021703	NA

- NOTE:**
1. The calibration interval of the above test instruments is 12 months and the calibrations are traceable to NML/ROC and NIST/USA.
  2. The test was performed in HwaYa Chamber 3.
  3. The horn antenna and HP preamplifier (model: 8449B) are used only for the measurement of emission frequency above 1GHz if tested.
  4. The VCCI Site Registration No. is R-237.
  5. The IC Site Registration No. is IC3789B-3.



#### 4.2.4 TEST PROCEDURES

- a. The EUT was placed on the top of a rotating table 0.8 meters above the ground at a 3 meters semi-anechoic chamber. The table was rotated 360 degrees to determine the position of the highest radiation.
- b. The EUT was set 1, 3 meters away from the interference-receiving antenna, which was mounted on the top of a variable-height antenna tower.
- c. The antenna is a broadband antenna, and its height is varied from one meter to four meters above the ground to determine the maximum value of the field strength. Both horizontal and vertical polarizations of the antenna are set to make the measurement.
- d. For each suspected emission, the EUT was arranged to its worst case and then the antenna was tuned to heights from 1 meter to 4 meters and the rotatable table was turned from 0 degrees to 360 degrees to find the maximum reading.

#### 4.2.5 DEVIATION FROM TEST STANDARD

No deviation

#### 4.2.6 TEST SETUP

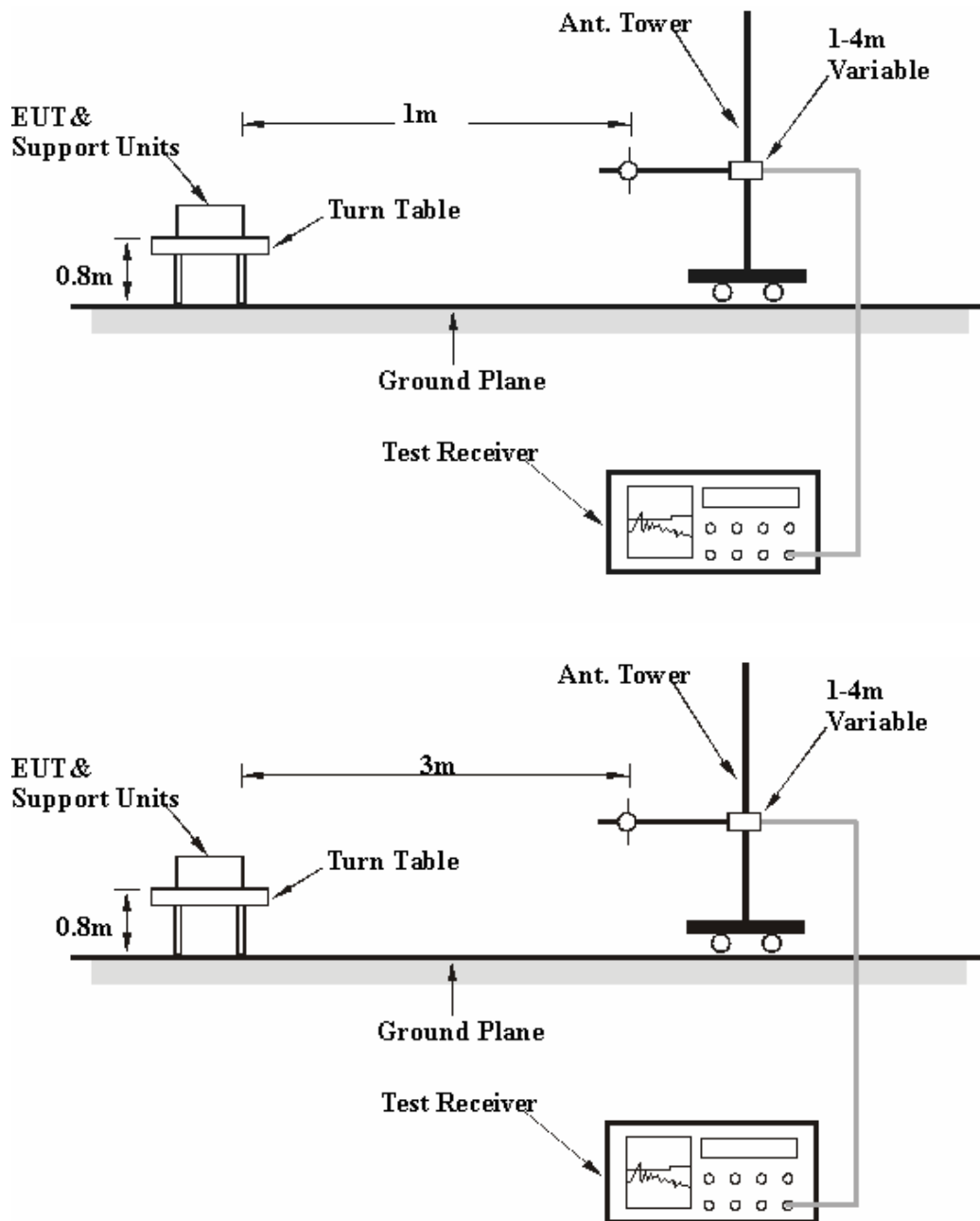

For the actual test configuration, please refer to the attached file (Test Setup Photo).

#### 4.2.7 EUT OPERATING CONDITIONS

Same as 4.1.6

## 4.2.8 TEST RESULTS

### RADIATED BELOW 960MHz WORST-CASE DATA

EUT TEST CONDITION		MEASUREMENT DETAIL	
SUB-BAND	1, 2, 3	FREQUENCY RANGE	Below 960MHz
MODULATION TECHNOLOGY	MOFDM	DETECTOR FUNCTION	Quasi-Peak
ENVIRONMENTAL CONDITIONS	20deg. C, 68%RH, 991hPa	INPUT POWER (SYSTEM)	120Vac, 60 Hz
TESTED BY	Dean Wang		

ANTENNA POLARITY & TEST DISTANCE: HORIZONTAL AT 3 M								
No.	Freq. (MHz)	Emission Level (dBuV/m)	Limit (dBuV/m)	Margin (dB)	Antenna Height (m)	Table Angle (Degree)	Raw Value (dBuV)	Correction Factor (dB/m)
1	263.99	44.12 QP	46.00	-1.88	1.00 H	19	30.21	13.91
2	331.92	38.42 QP	46.00	-7.58	1.00 H	139	22.44	15.99
3	466.11	37.80 QP	46.00	-8.20	1.50 H	73	18.11	19.69
4	528.00	42.86 QP	46.00	-3.14	1.32 H	5	22.03	20.83
5	792.01	41.35 QP	46.00	-4.65	1.00 H	354	15.50	25.85
6	859.36	36.63 QP	46.00	-9.37	1.00 H	298	9.55	27.08

ANTENNA POLARITY & TEST DISTANCE: VERTICAL AT 3 M								
No.	Freq. (MHz)	Emission Level (dBuV/m)	Limit (dBuV/m)	Margin (dB)	Antenna Height (m)	Table Angle (Degree)	Raw Value (dBuV)	Correction Factor (dB/m)
1	264.00	41.37 QP	46.00	-4.63	1.00 V	119	27.46	13.91
2	331.92	43.39 QP	46.00	-2.61	1.50 V	10	27.40	15.99
3	449.34	40.59 QP	46.00	-5.41	1.00 V	157	21.21	19.38
4	462.38	38.32 QP	46.00	-7.68	1.00 V	7	18.70	19.62
5	528.01	44.72 QP	46.00	-1.28	1.00 V	27	23.89	20.83
6	792.01	42.16 QP	46.00	-3.84	1.18 V	14	16.31	25.85

- REMARKS:**
1. Emission level(dBuV/m)=Raw Value(dBuV) + Correction Factor(dB/m)
  2. Correction Factor(dB/m) = Antenna Factor (dB/m) + Cable Factor (dB)
  3. The other emission levels were very low against the limit.
  4. Margin value = Emission level – Limit value.

**RADIATED ABOVE 960MHz DATA**

EUT TEST CONDITION		MEASUREMENT DETAIL	
SUB-BAND	1, 2, 3	FREQUENCY RANGE	960MHz ~ 40GHz
MODULATION TECHNOLOGY	MOFDM	DETECTOR FUNCTION	RMS
INPUT POWER (SYSTEM)	120Vac, 60 Hz	ENVIRONMENTAL CONDITIONS	20deg. C, 68%RH, 991hPa
TESTED BY	Dean Wang		

ANTENNA POLARITY & TEST DISTANCE: HORIZONTAL AT 1 M								
No.	Freq. (MHz)	Emission Level (dBuV/m)	Limit (dBuV/m)	Margin (dB)	Antenna Height (m)	Table Angle (Degree)	Raw Value (dBuV)	Correction Factor (dB/m)
1	1848.00	45.32	51.44	-6.12	1.00 H	321	14.16	31.16
2	2112.00	42.54	53.44	-10.90	1.00 H	342	10.69	31.85
3	2376.00	42.01	53.44	-11.43	1.00 H	301	9.22	32.79
4	2640.00	43.65	53.44	-9.79	1.00 H	295	10.00	33.65
5	2904.00	49.68	53.44	-3.76	1.00 H	353	15.13	34.55
6	3168.00	54.46	63.44	-8.98	1.00 H	306	19.35	35.11
7	3432.00	58.13	63.44	-5.31	1.00 H	321	22.46	35.67
8	3960.00	57.53	63.44	-5.91	1.00 H	332	20.02	37.51
9	4488.00	59.95	63.44	-3.49	1.00 H	326	20.99	38.96
10	6864.00	49.59	63.44	-13.85	1.00 H	215	3.49	46.10
11	7920.00	49.62	63.44	-13.82	1.00 H	215	2.12	47.51
12	8976.00	49.20	63.44	-14.24	1.00 H	258	1.20	48.00

- REMARKS:**
1. Emission level(dBuV/m)=Raw Value(dBuV) + Correction Factor(dB/m)
  2. Correction Factor(dB/m) = Antenna Factor (dB/m) + Cable Factor (dB)
  3. The other emission levels were very low against the limit.
  4. Margin value = Emission level – Limit value.

EUT TEST CONDITION		MEASUREMENT DETAIL	
SUB-BAND	1, 2, 3	FREQUENCY RANGE	960MHz ~ 40GHz
MODULATION TECHNOLOGY	MOFDM	DETECTOR FUNCTION	RMS
INPUT POWER (SYSTEM)	120Vac, 60 Hz	ENVIRONMENTAL CONDITIONS	20deg. C, 68%RH, 991hPa
TESTED BY	Dean Wang		

ANTENNA POLARITY & TEST DISTANCE: VERTICAL AT 1 M								
No.	Freq. (MHz)	Emission Level (dBuV/m)	Limit (dBuV/m)	Margin (dB)	Antenna Height (m)	Table Angle (Degree)	Raw Value (dBuV)	Correction Factor (dB/m)
1	1848.00	41.39	51.44	-10.05	1.00 V	307	10.23	31.16
2	2112.00	38.69	53.44	-14.75	1.00 V	326	6.84	31.85
3	2376.00	39.28	53.44	-14.16	1.00 V	324	6.49	32.79
4	2640.00	40.23	53.44	-13.21	1.00 V	328	6.58	33.65
5	2904.00	43.02	53.44	-10.42	1.00 V	314	8.47	34.55
6	3168.00	51.22	63.44	-12.22	1.00 V	316	16.11	35.11
7	3432.00	57.82	63.44	-5.62	1.07 V	25	22.15	35.67
8	3960.00	60.33	63.44	-3.11	1.08 V	35	22.82	37.51
9	4488.00	61.18	63.44	-2.26	1.00 V	24	22.22	38.96
10	6864.00	49.23	63.44	-14.21	1.00 V	225	3.13	46.10
11	7920.00	49.90	63.44	-13.54	1.00 V	206	2.40	47.51
12	8976.00	49.19	63.44	-14.25	1.00 V	198	1.19	48.00

- REMARKS:**
1. Emission level(dBuV/m)=Raw Value(dBuV) + Correction Factor(dB/m)
  2. Correction Factor(dB/m) = Antenna Factor (dB/m) + Cable Factor (dB)
  3. The other emission levels were very low against the limit.
  4. Margin value = Emission level – Limit value.

### EMISSIONS FROM DIGITAL CIRCUITRY

EUT TEST CONDITION		MEASUREMENT DETAIL	
SUB-BAND	1, 2, 3	FREQUENCY RANGE	Below 1GHz
MODULATION TECHNOLOGY	MOFDM	DETECTOR FUNCTION	Quasi - Peak
INPUT POWER (SYSTEM)	120Vac, 60 Hz	ENVIRONMENTAL CONDITIONS	20deg. C, 68%RH, 991hPa
TESTED BY	Dean Wang		

ANTENNA POLARITY & TEST DISTANCE: HORIZONTAL AT 1 M								
No.	Freq. (MHz)	Emission Level (dBuV/m)	Limit (dBuV/m)	Margin (dB)	Antenna Height (m)	Table Angle (Degree)	Raw Value (dBuV)	Correction Factor (dB/m)
1	990.00	44.96 QP	63.54	-18.58	1.00 H	306	15.48	29.48

ANTENNA POLARITY & TEST DISTANCE: VERTICAL AT 1 M								
No.	Freq. (MHz)	Emission Level (dBuV/m)	Limit (dBuV/m)	Margin (dB)	Antenna Height (m)	Table Angle (Degree)	Raw Value (dBuV)	Correction Factor (dB/m)
1	990.00	41.21 QP	63.54	-22.33	1.00 V	325	11.73	29.48

#### REMARKS:

1. Emission source vs. possible corresponding spurious:

Emission Source	Frequency (MHz)	Possible corresponding spurious CW tones (MHz) (X times harmonic)
DLL	330.00	990 (x3)

2. Emission level(dBuV/m)=Raw Value(dBuV) + Correction Factor(dB/m)

3. Correction Factor(dB/m) = Antenna Factor (dB/m) + Cable Factor (dB)

4. The other emission levels were very low against the limit.

5. Margin value = Emission level – Limit value.



EUT TEST CONDITION		MEASUREMENT DETAIL	
SUB-BAND	1, 2, 3	FREQUENCY RANGE	Above 1GHz
MODULATION TECHNOLOGY	MOFDM	DETECTOR FUNCTION	Peak / Average
INPUT POWER (SYSTEM)	120Vac, 60 Hz	ENVIRONMENTAL CONDITIONS	20deg. C, 68%RH, 991hPa
TESTED BY	Dean Wang		

ANTENNA POLARITY & TEST DISTANCE: HORIZONTAL AT 1 M								
No.	Freq. (MHz)	Emission Level (dBuV/m)	Limit (dBuV/m)	Margin (dB)	Antenna Height (m)	Table Angle (Degree)	Raw Value (dBuV)	Correction Factor (dB/m)
1	1056.00	54.01 PK	83.54	-29.53	1.00 H	354	24.41	29.60
1	1056.00	53.78 AV	63.54	-9.76	1.00 H	354	24.18	29.60
2	1122.00	41.02 PK	83.54	-42.52	1.00 H	342	11.28	29.75
2	1122.00	38.73 AV	63.54	-24.81	1.00 H	342	8.99	29.75
3	1188.00	48.68 PK	83.54	-34.86	1.00 H	350	18.75	29.93
3	1188.00	35.21 AV	63.54	-28.33	1.00 H	350	5.28	29.93
4	1200.00	47.13 PK	83.54	-36.41	1.00 H	315	17.17	29.96
4	1200.00	33.43 AV	63.54	-30.11	1.00 H	315	3.47	29.96
5	1254.00	42.95 PK	83.54	-40.59	1.00 H	343	12.89	30.06
5	1254.00	34.32 AV	63.54	-29.22	1.00 H	343	4.26	30.06
6	1320.00	50.80 PK	83.54	-32.74	1.00 H	332	20.60	30.20
6	1320.00	47.54 AV	63.54	-16.00	1.00 H	332	17.34	30.20
7	1518.00	44.32 PK	83.54	-39.22	1.00 H	2	13.67	30.65
7	1518.00	33.95 AV	63.54	-29.59	1.00 H	2	3.30	30.65
8	1584.00	47.38 PK	83.54	-36.16	1.00 H	18	16.61	30.76
8	1584.00	42.70 AV	63.54	-20.84	1.00 H	18	11.93	30.76

**REMARKS:**

1. Emission source vs. possible corresponding spurious:

Emission Source	Frequency (MHz)	Possible corresponding spurious CW tones (MHz) (X times harmonic)
PLL	1056.00	1056 (x1)
PLL	528.00	1056 (x2), 1584 (x3)
DLL	330.00	1320 (x4)
PLL	264.00	1056 (x4)
XTAL of PHY	66.00	1056 (x16), 1122 (x17), 1188 (x18), 1254 (x19), 1518 (x23)
XTAL of MAC	30.00	1200 (x40)

- Emission level(dBuV/m)=Raw Value(dBuV) + Correction Factor(dB/m)
- Correction Factor(dB/m) = Antenna Factor (dB/m) + Cable Factor (dB)
- The other emission levels were very low against the limit.
- Margin value = Emission level – Limit value.



EUT TEST CONDITION		MEASUREMENT DETAIL	
SUB-BAND	1, 2, 3	FREQUENCY RANGE	Above 1GHz
MODULATION TECHNOLOGY	MOFDM	DETECTOR FUNCTION	Peak / Average
INPUT POWER (SYSTEM)	120Vac, 60 Hz	ENVIRONMENTAL CONDITIONS	20deg. C, 68%RH, 991hPa
TESTED BY	Dean Wang		

ANTENNA POLARITY & TEST DISTANCE: VERTICAL AT 1 M								
No.	Freq. (MHz)	Emission Level (dBuV/m)	Limit (dBuV/m)	Margin (dB)	Antenna Height (m)	Table Angle (Degree)	Raw Value (dBuV)	Correction Factor (dB/m)
1	1056.00	51.74 PK	83.54	-31.80	1.00 V	330	22.14	29.60
1	1056.00	46.46 AV	63.54	-17.08	1.00 V	330	16.86	29.60
2	1122.00	43.09 PK	83.54	-40.45	1.00 V	128	13.35	29.75
2	1122.00	31.36 AV	63.54	-32.18	1.00 V	128	1.62	29.75
3	1188.00	46.89 PK	83.54	-36.65	1.00 V	325	16.96	29.93
3	1188.00	31.57 AV	63.54	-31.97	1.00 V	325	1.64	29.93
4	1200.00	45.76 PK	83.54	-37.78	1.00 V	143	15.80	29.96
4	1200.00	30.13 AV	63.54	-33.41	1.00 V	143	0.17	29.96
5	1254.00	41.50 PK	83.54	-42.04	1.00 V	242	11.44	30.06
5	1254.00	28.88 AV	63.54	-34.66	1.00 V	242	-1.18	30.06
6	1320.00	44.19 PK	83.54	-39.35	1.05 V	102	13.99	30.20
6	1320.00	36.12 AV	63.54	-27.42	1.05 V	102	5.92	30.20
7	1518.00	43.96 PK	83.54	-39.58	1.00 V	160	13.31	30.65
7	1518.00	29.25 AV	63.54	-34.29	1.00 V	160	-1.40	30.65
8	1584.00	45.93 PK	83.54	-37.61	1.20 V	158	15.16	30.76
8	1584.00	40.00 AV	63.54	-23.54	1.20 V	158	9.23	30.76

**REMARKS:**

1. Emission source vs. possible corresponding spurious:

Emission Source	Frequency (MHz)	Possible corresponding spurious CW tones (MHz) (X times harmonic)
PLL	1056.00	1056 (x1)
PLL	528.00	1056 (x2), 1584 (x3)
DLL	330.00	1320 (x4)
PLL	264.00	1056 (x4)
XTAL of PHY	66.00	1056 (x16), 1122 (x17), 1188 (x18), 1254 (x19), 1518 (x23)
XTAL of MAC	30.00	1200 (x40)

- Emission level(dBuV/m)=Raw Value(dBuV) + Correction Factor(dB/m)
- Correction Factor(dB/m) = Antenna Factor (dB/m) + Cable Factor (dB)
- The other emission levels were very low against the limit.
- Margin value = Emission level – Limit value.

### TERMINATED ANTENNA PORT

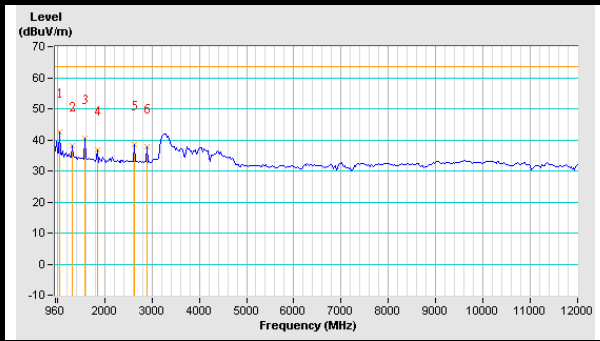

### CONDUCTED ANTENNA PORT

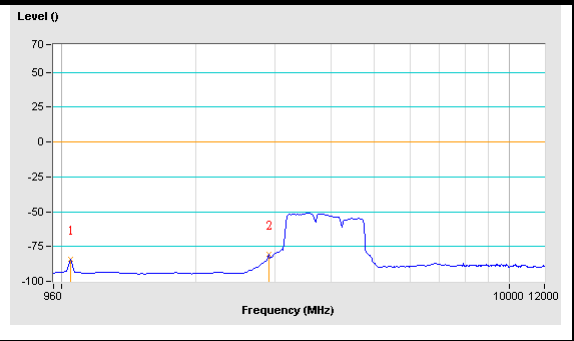

### 4.3 RADIATED EMISSION MEASUREMENT (FOR 15.517 (d))

#### 4.3.1 LIMITS OF RADIATED EMISSION MEASUREMENT

FREQUENCY IN MHz	EIRP IN dBm	dBuV/m@3m	dBuV/m@1m
1,164 ~ 1,240	-85.3	9.9	19.44
1,559 ~ 1,610	-85.3	9.9	19.44

Transfer rules follow 15.521(g), 15.31(f)(1).

- NOTE:** 1. 15.521(g) converted to a peak field strength level at 3 meters using  $E(\text{dBuV/m}) = P(\text{dBmEIRP}) + 95.2$ .
2. 15.31(f)(1) When performing measurements at a distance other than that specified, the results shall be extrapolated to the specified distance using an extrapolation factor of 20 dB/decade, Measurement distance moves from 3m to 1m,  $\text{Limit (1m)} = \text{Limit (3m)} + 20\text{Log (3/1)} = \text{Limit (3m)} + 9.54$ .

#### Instrument Noise Floor

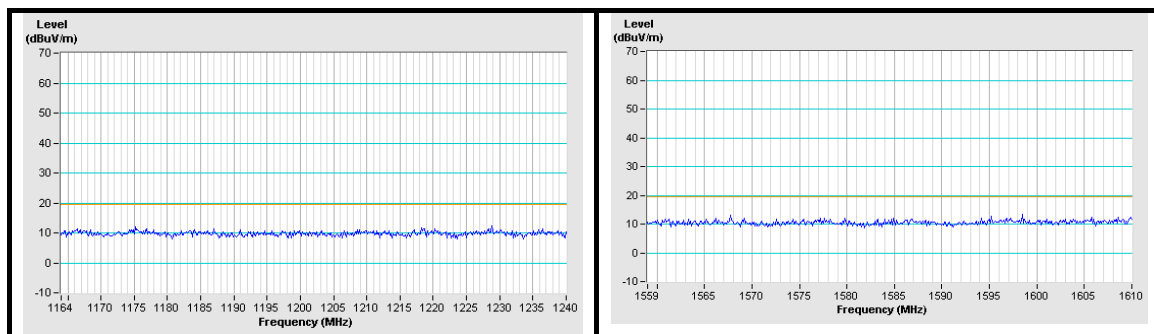

15.521(c) Emissions from digital circuitry used to enable the operation of the UWB transmitter shall comply with the limits in Section 15.209 of this chapter, rather than the limits specified in this subpart.

- NOTE:** Use conducted measurement to determine emissions is from digital circuitry or not.  
Emissions from digital circuitry follow 15.209 else 15.517

The radiated emissions above 1000MHz from a device operating under the provisions of this section shall not exceed the emission levels in Section 15.209.

FREQUENCY IN MHz	dBuV/m@3m		dBuV/m@1m	
	Peak	Average	Peak	Average
Above 1000	74.00	54.00	83.54	63.54

#### 4.3.2 INSTRUMENT SETUP VALUE AND MEASUREMENT DISTANCE

UWB transmitters operating under the provisions of this section shall not exceed the following average limits when measured using a resolution bandwidth of no less than 1 kHz:

FREQUENCY RANGE	RESOLUTION BANDWIDTH	VIDEO BANDWIDTH	DETECTOR	MEASUREMENT DISTANCE
1,164 ~ 1,240	*10kHz	30kHz	RMS	1 meter
1,559 ~ 1,610	*10kHz	30kHz	RMS	1 meter

**NOTE:** \*reference The Evolution of Modern UWB Technology.



### 4.3.3 TEST INSTRUMENTS

DESCRIPTION & MANUFACTURER	MODEL NO.	SERIAL NO.	CALIBRATED UNTIL
Test Receiver ROHDE & SCHWARZ	ESI7	100033	May 22, 2007
Spectrum Analyzer ROHDE & SCHWARZ	FSP40	100025	Oct. 05, 2007
BILOG Antenna SCHWARZBECK	VULB9168	9168-160	May 31, 2007
HORN Antenna SCHWARZBECK	9120D	9120D-209	Jun. 27, 2007
HORN Antenna SCHWARZBECK	BBHA 9170	BBHA9170243	Dec. 28, 2007
Preamplifier Agilent	8447D	2944A10633	Oct. 26, 2007
Preamplifier Agilent	8449B	3008A01964	Oct. 26, 2007
RF signal cable HUBER+SUHNNER	SUCOFLEX 104	238137/4	Dec. 11, 2007
RF signal cable HUBER+SUHNNER	SUCOFLEX 104	233233/4	Nov. 14, 2007
Software ADT.	ADT_Radiated_V7.6	NA	NA
Antenna Tower inn-co GmbH	MA 4000	013303	NA
Antenna Tower Controller inn-co GmbH	CO2000	017303	NA
Turn Table ADT.	TT100.	TT93021703	NA
Turn Table Controller ADT.	SC100.	SC93021703	NA

- NOTE:**
1. The calibration interval of the above test instruments is 12 months and the calibrations are traceable to NML/ROC and NIST/USA.
  2. The test was performed in HwaYa Chamber 3.
  3. The horn antenna and HP preamplifier (model: 8449B) are used only for the measurement of emission frequency above 1GHz if tested.
  4. The VCCI Site Registration No. is R-237.
  5. The IC Site Registration No. is IC3789B-3.



#### 4.3.4 TEST PROCEDURES

- e. The EUT was placed on the top of a rotating table 0.8 meters above the ground at a 1 meters semi-anechoic chamber. The table was rotated 360 degrees to determine the position of the highest radiation.
- f. The EUT was set 1 meters away from the interference-receiving antenna, which was mounted on the top of a variable-height antenna tower.
- g. The antenna is a broadband antenna, and its height is varied from one meter to four meters above the ground to determine the maximum value of the field strength. Both horizontal and vertical polarizations of the antenna are set to make the measurement.
- h. For each suspected emission, the EUT was arranged to its worst case and then the antenna was tuned to heights from 1 meter to 4 meters and the rotatable table was turned from 0 degrees to 360 degrees to find the maximum reading.

#### 4.3.5 DEVIATION FROM TEST STANDARD

No deviation

#### 4.3.6 TEST SETUP

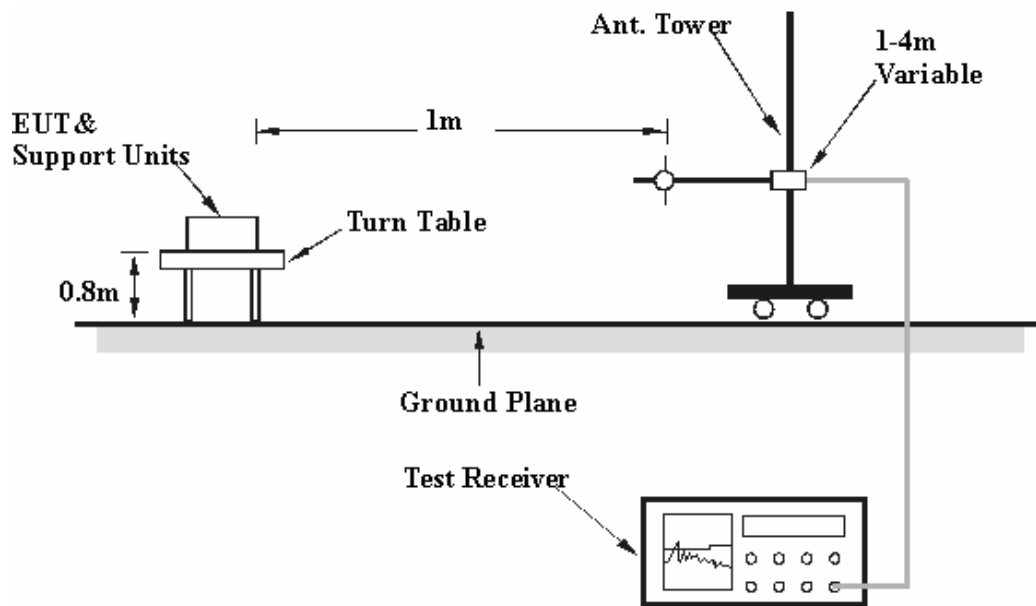

For the actual test configuration, please refer to the attached file (Test Setup Photo).

#### 4.3.7 EUT OPERATING CONDITIONS

Same as 4.1.6

#### 4.3.8 TEST RESULTS

##### EMISSIONS FROM DIGITAL CIRCUITRY

EUT TEST CONDITION		MEASUREMENT DETAIL	
SUB-BAND	1, 2, 3	FREQUENCY RANGE	Above 1GHz
MODULATION TECHNOLOGY	MOFDM	DETECTOR FUNCTION	Peak / Average
INPUT POWER (SYSTEM)	120Vac, 60 Hz	ENVIRONMENTAL CONDITIONS	25deg. C, 68%RH, 991hPa
TESTED BY	Morgan Chen		

ANTENNA POLARITY & TEST DISTANCE: HORIZONTAL AT 1 M								
No.	Freq. (MHz)	Emission Level (dBuV/m)	Limit (dBuV/m)	Margin (dB)	Antenna Height (m)	Table Angle (Degree)	Raw Value (dBuV)	Correction Factor (dB/m)
1	1188.00	48.68 PK	83.54	-34.86	1.00 H	350	18.75	29.93
1	1188.00	35.21 AV	63.54	-28.33	1.00 H	350	5.28	29.93
2	1200.00	47.13 PK	83.54	-36.41	1.00 H	315	17.17	29.96
2	1200.00	33.43 AV	63.54	-30.11	1.00 H	315	3.47	29.96
3	1584.00	47.38 PK	83.54	-36.16	1.00 H	18	16.61	30.76
3	1584.00	42.70 AV	63.54	-20.84	1.00 H	18	11.93	30.76

ANTENNA POLARITY & TEST DISTANCE: VERTICAL AT 1 M								
No.	Freq. (MHz)	Emission Level (dBuV/m)	Limit (dBuV/m)	Margin (dB)	Antenna Height (m)	Table Angle (Degree)	Raw Value (dBuV)	Correction Factor (dB/m)
1	1188.00	46.89 PK	83.54	-36.65	1.00 V	325	16.96	29.93
1	1188.00	31.57 AV	63.54	-31.97	1.00 V	325	1.64	29.93
2	1200.00	45.76 PK	83.54	-37.78	1.00 V	143	15.80	29.96
2	1200.00	30.13 AV	63.54	-33.41	1.00 V	143	0.17	29.96
3	1584.00	45.93 PK	83.54	-37.61	1.20 V	158	15.16	30.76
3	1584.00	40.00 AV	63.54	-23.54	1.20 V	158	9.23	30.76

##### REMARKS:

1. Emission source vs. possible corresponding spurious:

Emission Source	Frequency (MHz)	Possible corresponding spurious CW tones (MHz) (X times harmonic)
PLL	528.00	1584 (x3)
XTAL of PHY	66.00	1188 (x18)
XTAL of MAC	30.00	1200 (x40)

2. Emission level(dBuV/m)=Raw Value(dBuV) + Correction Factor(dB/m)

3. Correction Factor(dB/m) = Antenna Factor (dB/m) + Cable Factor (dB)

4. The other emission levels were very low against the limit.

5. Margin value = Emission level – Limit value.

### TERMINATED ANTENNA PORT

### CONDUCTED ANTENNA PORT

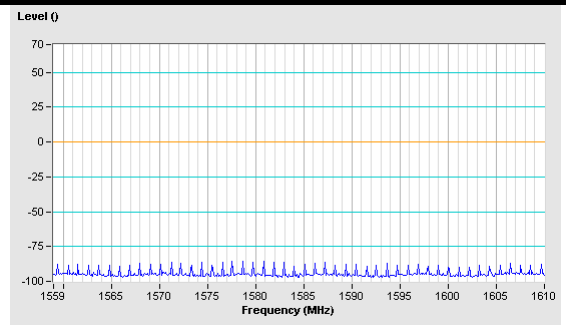
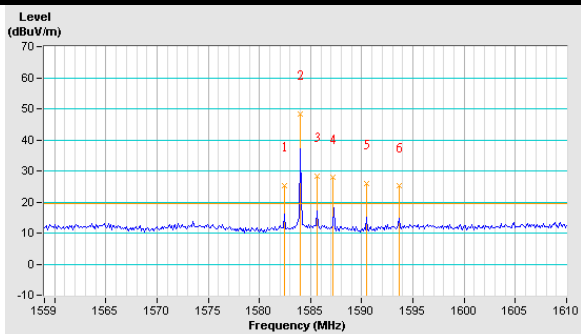
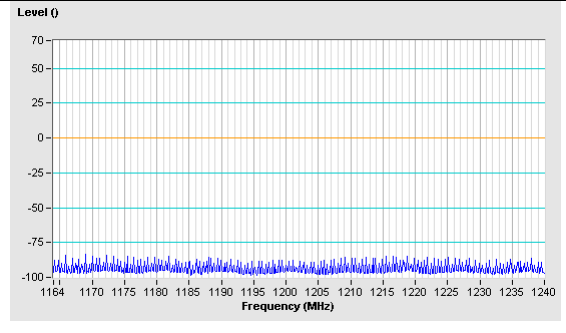
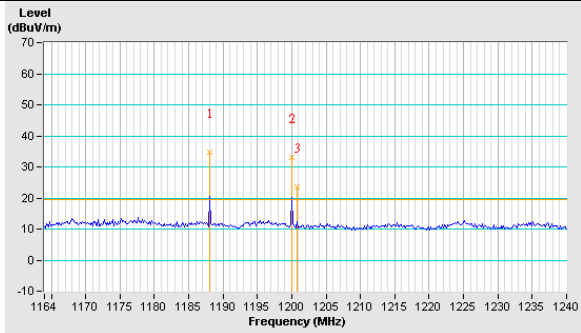

#### 4.4 UWB BANDWIDTH MEASUREMENT

##### 4.4.1 LIMITS OF UWB BANDWIDTH MEASUREMENT

The UWB bandwidth of a UWB system operating under the provisions of this section must be contained between 3100 MHz and 10,600 MHz.

##### 4.4.2 INSTRUMENT SETUP VALUE AND MEASUREMENT DISTANCE

FREQUENCY RANGE	RESOLUTION BANDWIDTH	VIDEO BANDWIDTH	DETECTOR	MEASUREMENT DISTANCE
3,100 ~ 10,600	1MHz	3MHz	Peak	3 meters

##### 4.4.3 TEST INSTRUMENT

Same as Item 4.2.3

##### 4.4.4 TEST PROCEDURE

- The EUT was placed on the top of a rotating table 0.8 meters above the ground at a 3 meters semi-anechoic chamber. The table was rotated 360 degrees to determine the position of the highest radiation.
- The EUT was set 3 meters away from the interference-receiving antenna, which was mounted on the top of a variable-height antenna tower.
- The antenna is a broadband antenna, and its height is varied from one meter to four meters above the ground to determine the maximum value of the field strength. Both horizontal and vertical polarizations of the antenna are set to make the measurement.
- For each suspected emission, the EUT was arranged to its worst case and then the antenna was tuned to heights from 1 meter to 4 meters and the rotatable table was turned from 0 degrees to 360 degrees to find the maximum reading.
- The Spectrum Analyzer system was set to Peak Detect Function and Specified Bandwidth with Maximum Hold Mode.
- The UWB Bandwidth is measured at the 10 dB point ( $F_L$ ,  $F_H$ ).

##### 4.4.5 DEVIATION FROM TEST STANDARD

No deviation



#### 4.4.6 TEST SETUP

Same as Item 4.2.6

#### 4.4.7 EUT OPERATING CONDITIONS

The software provided by client to enable the EUT under transmission condition continuously.



#### 4.4.8 TEST RESULTS

<b>MODULATION TECHNOLOGY</b>	MOFDM	<b>ENVIRONMENTAL CONDITIONS</b>	26deg.C, 66%RH, 991hPa
<b>INPUT POWER (SYSTEM)</b>	120Vac, 60 Hz	<b>TESTED BY</b>	Morgan Chen

$F_L$ (MHz)	$F_H$ (MHz)	$F_C=(F_L+F_H)/2$ (MHz)	LIMIT (MHz)	PASS/FAIL
3176.00	4744.00	3960.00	Between 3100.00 ~ 10600.00	PASS

UWB Bandwidth =  $F_H - F_L = 1568\text{MHz}$

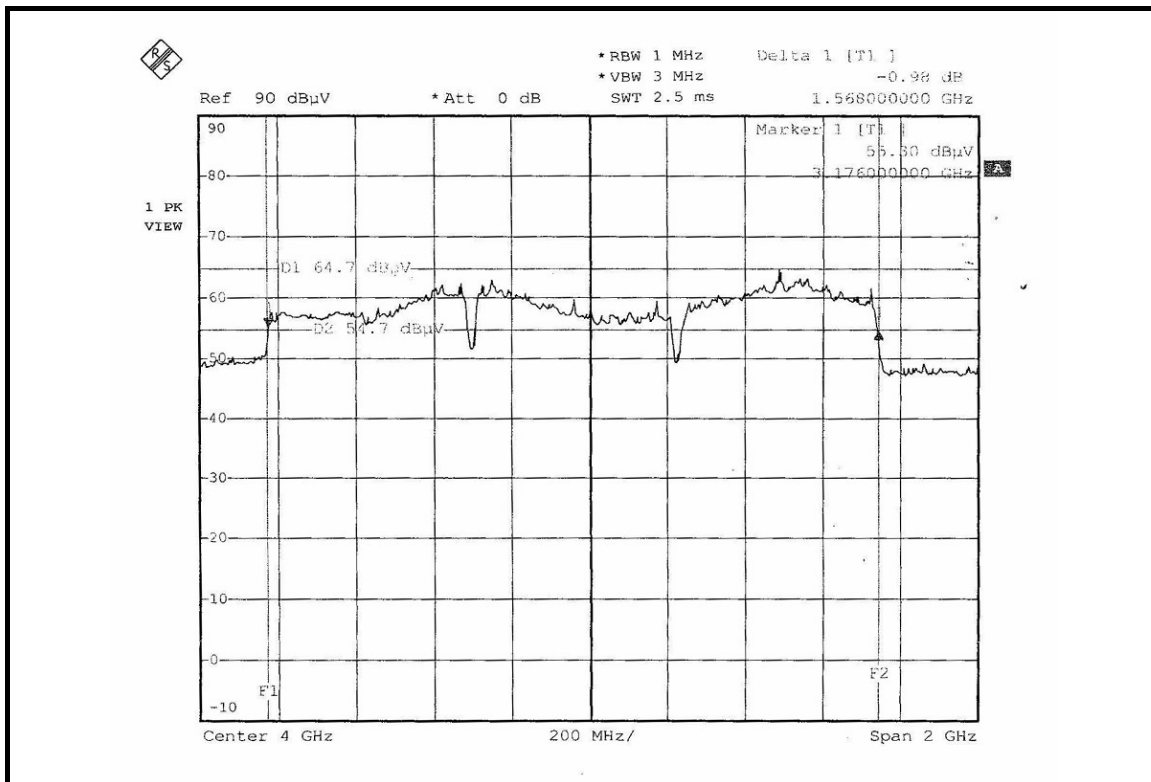



## 4.5 PEAK EMISSION WITHIN A 50MHz BANDWIDTH

### 4.5.1 LIMITS OF PEAK EMISSION

The Maximum Peak Output Power Measurement is 0dBm(RBW=50MHz)

If a resolution bandwidth other than 50 MHz is Employed, the peak EIRP limit shall be  $20 \log (RBW/50)$  dBm where RBW is the resolution bandwidth in megahertz that is employed. The resolution bandwidth used to make the peak measurement was 3 MHz, resulting in a limit of  $-24.44$ dBm

This may be converted to a peak field strength level at 3 meters using

$$E(\text{dBuV/m}) = P(\text{dBm EIRP}) + 95.2 = -24.44 + 95.2 = 70.76.$$

### 4.5.2 INSTRUMENT SETUP VALUE AND MEASUREMENT DISTANCE

#### RADIATED EMISSIONS 15.517 (e):

FREQUENCY RANGE	RESOLUTION BANDWIDTH	VIDEO BANDWIDTH	DETECTOR	MEASUREMENT DISTANCE
3,100 ~ 10,600	3MHz	10MHz	*Peak	3 meters

**NOTE:** \*reference The Evolution of Modern UWB Technology

#### 4.5.3 TEST INSTRUMENTS

Same as 4.2.3

#### 4.5.4 TEST PROCEDURE

Same as 4.2.4

#### 4.5.5 DEVIATION FROM TEST STANDARD

No deviation

#### 4.5.6 TEST SETUP

Same as Item 4.2.6

#### 4.5.7 EUT OPERATING CONDITIONS

Same as 4.1.6



#### 4.5.8 TEST RESULTS

<b>MODULATION TECHNOLOGY</b>	MOFDM	<b>ENVIRONMENTAL CONDITIONS</b>	25deg. C, 60%RH, 991hPa
<b>INPUT POWER (SYSTEM)</b>	120Vac, 60 Hz	<b>TESTED BY</b>	Dean Wang

ANTENNA POLARITY & TEST DISTANCE AT 3 M								
No.	Freq. (MHz)	Emission Level (dBuV/m)	Limit (dBuV/m)	Margin (dB)	Antenna Height (m)	Table Angle (Degree)	Raw Value (dBuV)	Correction Factor (Db/m)
1	3664.00	68.03 PK	70.76	-2.73	1.00 H	258	32.04	35.99
2	3728.00	67.53 PK	70.76	-3.23	1.00 H	258	31.33	36.20
3	4492.00	66.14 PK	70.76	-4.62	1.00 H	258	28.17	37.97
1	3664.00	66.24 PK	70.76	-4.52	1.09 V	65	30.25	35.99
2	3760.00	66.49 PK	70.76	-4.27	1.09 V	65	30.18	36.31
3	4492.00	68.97 PK	70.76	-1.79	1.09 V	65	31.00	37.97



## **4.6 ANTENNA REQUIREMENT**

### **4.6.1 STANDARD APPLICABLE**

For intentional device, according to FCC 47 CFR Section 15.203, an intentional radiator shall be designed to ensure that no antenna other than that furnished by the responsible party shall be used with the device.

### **4.6.2 ANTENNA CONNECTED CONSTRUCTION**

The antenna used in this product is Metal antenna without antenna connector. The maximum Gain of the antenna is 2dBi.



## 5 INFORMATION ON THE TESTING LABORATORIES

We, ADT Corp., were founded in 1988 to provide our best service in EMC, Radio, Telecom and Safety consultation. Our laboratories are accredited and approved by the following approval agencies according to ISO/IEC 17025

<b>USA</b>	FCC, UL
<b>Germany</b>	TUV Rheinland
<b>Japan</b>	VCCI
<b>Norway</b>	NEMKO
<b>Canada</b>	INDUSTRY CANADA , CSA
<b>R.O.C.</b>	CNLA, BSMI, NCC
<b>Netherlands</b>	Telefication
<b>Singapore</b>	PSB , GOST-ASIA(MOU)
<b>Russia</b>	CERTIS(MOU)

Copies of accreditation certificates of our laboratories obtained from approval agencies can be downloaded from our web site: [www.adt.com.tw/index.5/phtml](http://www.adt.com.tw/index.5/phtml).  
If you have any comments, please feel free to contact us at the following:

**Linko EMC/RF Lab:**  
Tel: 886-2-26052180  
Fax: 886-2-26051924

**Hsin Chu EMC/RF Lab:**  
Tel: 886-3-5935343  
Fax: 886-3-5935342

**Hwa Ya EMC/RF/Safety/Telecom Lab:**  
Tel: 886-3-3183232  
Fax: 886-3-3185050

**Web Site:** [www.adt.com.tw](http://www.adt.com.tw)

The address and road map of all our labs can be found in our web site also.



## **APPENDIX-A**

### **MODIFICATIONS RECORDERS FOR ENGINEERING CHANGES TO THE EUT BY THE LAB**

No any modifications are made to the EUT by the lab during the test.