

FCC Test Report

Report No.: RF150721D03

FCC ID: KA2SL2885AA1

Test Model: DSL-2885A

Received Date: Aug. 28, 2015

Test Date: Sep. 4 ~ Oct. 8, 2015

Issued Date: Nov. 25, 2015

Applicant: D-Link Corporation

Address: No.289, Sinhu 3rd Rd., Neihu District, Taipei City 114, Taiwan, R.O.C.

Issued By: Bureau Veritas Consumer Products Services (H.K.) Ltd., Taoyuan Branch

Lab Address: No. 47-2, 14th Ling, Chia Pau Vil., Lin Kou Dist., New Taipei City, Taiwan (R.O.C.)



This report is for your exclusive use. Any copying or replication of this report to or for any other person or entity, or use of our name or trademark, is permitted only with our prior written permission. This report sets forth our findings solely with respect to the test samples identified herein. The results set forth in this report are not indicative or representative of the quality or characteristics of the lot from which a test sample was taken or any similar or identical product unless specifically and expressly noted. Our report includes all of the tests requested by you and the results thereof based upon the information that you provided to us. You have 60 days from date of issuance of this report to notify us of any material error or omission caused by our negligence, provided, however, that such notice shall be in writing and shall specifically address the issue you wish to raise. A failure to raise such issue within the prescribed time shall constitute your unqualified acceptance of the completeness of this report, the tests conducted and the correctness of the report contents. Unless specific mention, the uncertainty of measurement has been explicitly taken into account to declare the compliance or non-compliance to the specification. The report must not be used by the client to claim product certification, approval, or endorsement by TAF or any government agencies.



Table of Contents

Release Control Record	4
1 Certificate of Conformity	5
2 Summary of Test Results	6
2.1 Measurement Uncertainty	6
2.2 Modification Record	6
3 General Information	7
3.1 General Description of EUT	7
3.2 Description of Test Modes	8
3.2.1 Test Mode Applicability and Tested Channel Detail	9
3.3 Duty Cycle of Test Signal	11
3.4 Description of Support Units	12
3.4.1 Configuration of System under Test	13
3.5 General Description of Applied Standards	14
4 Test Types and Results	15
4.1 Radiated Emission and Bandedge Measurement.....	15
4.1.1 Limits of Radiated Emission and Bandedge Measurement	15
4.1.2 Test Instruments	16
4.1.3 Test Procedures.....	17
4.1.4 Deviation from Test Standard	17
4.1.5 Test Set Up	18
4.1.6 EUT Operating Conditions.....	18
4.1.7 Test Results	19
4.2 Conducted Emission Measurement	32
4.2.1 Limits of Conducted Emission Measurement	32
4.2.2 Test Instruments	32
4.2.3 Test Procedures.....	33
4.2.4 Deviation from Test Standard	33
4.2.5 Test Setup.....	33
4.2.6 EUT Operating Conditions.....	33
4.2.7 Test Results	34
4.3 6dB Bandwidth Measurement	36
4.3.1 Limits of 6dB Bandwidth Measurement	36
4.3.2 Test Setup.....	36
4.3.3 Test Instruments	36
4.3.4 Test Procedure	36
4.3.5 Deviation from Test Standard	36
4.3.6 EUT Operating Conditions.....	36
4.3.7 Test Result.....	37
4.4 Conducted Output Power Measurement.....	39
4.4.1 Limits of Conducted Output Power Measurement	39
4.4.2 Test Setup.....	39
4.4.3 Test Instruments	39
4.4.4 Test Procedures.....	39
4.4.5 Deviation from Test Standard	39
4.4.6 EUT Operating Conditions.....	39
4.4.7 Test Results	40
4.5 Power Spectral Density Measurement.....	42
4.5.1 Limits of Power Spectral Density Measurement.....	42
4.5.2 Test Setup.....	42
4.5.3 Test Instruments	42
4.5.4 Test Procedure	42
4.5.5 Deviation from Test Standard	42



4.5.6 EUT Operating Condition	42
4.5.7 Test Results	43
4.6 Conducted Out of Band Emission Measurement.....	45
4.6.1 Limits of Conducted Out of Band Emission Measurement.....	45
4.6.2 Test Setup.....	45
4.6.3 Test Instruments	45
4.6.4 Test Procedure	45
4.6.5 Deviation from Test Standard	45
4.6.6 EUT Operating Condition	45
4.6.7 Test Results	45
5 Pictures of Test Arrangements.....	54
Appendix – Information on the Testing Laboratories	55



Release Control Record

Issue No.	Description	Date Issued
RF150721D03	Original release.	Nov. 25, 2015



1 Certificate of Conformity

Product: Wireless AC1200 Dual-Band Gigabit ADSL2+/VDSL2 Modem Router

Brand: D-Link

Test Model: DSL-2885A

Sample Status: Engineering sample

Applicant: D-Link Corporation

Test Date: Sep. 4 ~ Oct. 8, 2015

Standards: 47 CFR FCC Part 15, Subpart C (Section 15.247)
ANSI C63.10: 2013

The above equipment has been tested by **Bureau Veritas Consumer Products Services (H.K.) Ltd., Taoyuan Branch**, and found compliance with the requirement of the above standards. The test record, data evaluation & Equipment Under Test (EUT) configurations represented herein are true and accurate accounts of the measurements of the sample's EMC characteristics under the conditions specified in this report.

Prepared by :

Annie Chang

Date:

Nov. 25, 2015

Annie Chang / Senior Specialist

Approved by :

Rex Lai

Date:

Nov. 25, 2015

Rex Lai / Assistant Manager

2 Summary of Test Results

47 CFR FCC Part 15, Subpart C (SECTION 15.247)			
FCC Clause	Test Item	Result	Remarks
15.207	AC Power Conducted Emission	PASS	Meet the requirement of limit. Minimum passing margin is -12.69dB at 0.15001MHz.
15.205 / 15.209 / 15.247(d)	Radiated Emissions and Band Edge Measurement	PASS	Meet the requirement of limit. Minimum passing margin is -1.1dB at 2483.50MHz.
15.247(d)	Antenna Port Emission	PASS	Meet the requirement of limit.
15.247(a)(2)	6dB bandwidth	PASS	Meet the requirement of limit.
15.247(b)	Conducted power	PASS	Meet the requirement of limit.
15.247(e)	Power Spectral Density	PASS	Meet the requirement of limit.
15.203	Antenna Requirement	PASS	Antenna connector is I-PEX not a standard connector.

2.1 Measurement Uncertainty

Where relevant, the following measurement uncertainty levels have been estimated for tests performed on the EUT as specified in CISPR 16-4-2:

Measurement	Frequency	Expanded Uncertainty (k=2) (\pm)
Conducted Emissions at mains ports	150kHz ~ 30MHz	3.43 dB
Radiated Emissions up to 1 GHz	30MHz ~ 1000MHz	4.00 dB
Radiated Emissions above 1 GHz	1GHz ~ 40GHz	3.36 dB

2.2 Modification Record

There were no modifications required for compliance.

3 General Information

3.1 General Description of EUT

Product	Wireless AC1200 Dual-Band Gigabit ADSL2+/VDSL2 Modem Router
Brand	D-Link
Test Model	DSL-2885A
Status of EUT	Engineering sample
Power Supply Rating	12Vdc from Adapter
Modulation Type	CCK, DQPSK, DBPSK for DSSS 64QAM, 16QAM, QPSK, BPSK for OFDM
Modulation Technology	DSSS, OFDM
Transfer Rate	802.11b: 11/5.5/2/1Mbps 802.11g: 54/48/36/24/18/12/9/6Mbps 802.11n: up to 300Mbps
Operating Frequency	2412 ~ 2462MHz
Number of Channel	11 for 802.11b, 802.11g, 802.11n (HT20) 7 for 802.11n (HT40)
Output Power	938.664mW
Antenna Type	Dipole antenna (I-PEX connector) with 3dBi gain
Antenna Connector	N/A
Accessory Device	Adapter
Data Cable Supplied	N/A

Note:

- The EUT incorporates a MIMO function. Physically, the EUT provides two completed transmitters and two receivers.

Modulation Mode	TX Function
802.11b	2TX
802.11g	2TX
802.11n (HT20)	2TX
802.11n (HT40)	2TX

- The EUT uses following adapter.

Brand	AMIGO
Model	AMS115-1202000FU
AC Input Power	100-240Vac, 50/60Hz, 0.8A Max
DC Output Power	12Vdc, 2.0A
Power Line	AC 2 Pin Non-shielded DC cable (1.2m).

- The above EUT information is declared by manufacturer and for more detailed features description, please refer to the manufacturer's specifications or user's manual.

3.2 Description of Test Modes

11 channels are provided for 802.11b, 802.11g and 802.11n (HT20):

Channel	Frequency	Channel	Frequency
1	2412MHz	7	2442MHz
2	2417MHz	8	2447MHz
3	2422MHz	9	2452MHz
4	2427MHz	10	2457MHz
5	2432MHz	11	2462MHz
6	2437MHz		

7 channels are provided for 802.11n (HT40):

Channel	Frequency	Channel	Frequency
3	2422MHz	7	2442MHz
4	2427MHz	8	2447MHz
5	2432MHz	9	2452MHz
6	2437MHz		

3.2.1 Test Mode Applicability and Tested Channel Detail

EUT CONFIGURE MODE	APPLICABLE TO				DESCRIPTION
	RE \geq 1G	RE<1G	PLC	APCM	
-	√	√	√	√	-

Where RE \geq 1G: Radiated Emission above 1GHz & Bandedge Measurement
 RE<1G: Radiated Emission below 1GHz
 PLC: Power Line Conducted Emission
 APCM: Antenna Port Conducted Measurement

Radiated Emission Test (Above 1GHz):

- Pre-Scan has been conducted to determine the worst-case mode from all possible combinations between available modulations, data rates and antenna ports (if EUT with antenna diversity architecture).
- Following channel(s) was (were) selected for the final test as listed below.

EUT CONFIGURE MODE	MODE	AVAILABLE CHANNEL	TESTED CHANNEL	MODULATION TECHNOLOGY	MODULATION TYPE	DATA RATE (Mbps)
-	802.11b	1 to 11	1, 6, 11	DSSS	DBPSK	1.0
-	802.11g	1 to 11	1, 6, 11	OFDM	BPSK	6.0
-	802.11n (HT20)	1 to 11	1, 6, 11	OFDM	BPSK	6.5
-	802.11n (HT40)	3 to 9	3, 6, 9	OFDM	BPSK	13.5

Radiated Emission Test (Below 1GHz):

- Pre-Scan has been conducted to determine the worst-case mode from all possible combinations between available modulations, data rates and antenna ports (if EUT with antenna diversity architecture).
- Following channel(s) was (were) selected for the final test as listed below.

EUT CONFIGURE MODE	MODE	AVAILABLE CHANNEL	TESTED CHANNEL	MODULATION TECHNOLOGY	MODULATION TYPE	DATA RATE (Mbps)
-	802.11n (HT20)	1 to 11	6	OFDM	BPSK	6.5

Power Line Conducted Emission Test:

- Pre-Scan has been conducted to determine the worst-case mode from all possible combinations between available modulations, data rates and antenna ports (if EUT with antenna diversity architecture).
- Following channel(s) was (were) selected for the final test as listed below.

EUT CONFIGURE MODE	MODE	AVAILABLE CHANNEL	TESTED CHANNEL	MODULATION TECHNOLOGY	MODULATION TYPE	DATA RATE (Mbps)
-	802.11n (HT20)	1 to 11	6	OFDM	BPSK	6.5

Antenna Port Conducted Measurement:

- This item includes all test value of each mode, but only includes spectrum plot of worst value of each mode.
- Pre-Scan has been conducted to determine the worst-case mode from all possible combinations between available modulations, data rates and antenna ports (if EUT with antenna diversity architecture).
- Following channel(s) was (were) selected for the final test as listed below.

EUT CONFIGURE MODE	MODE	AVAILABLE CHANNEL	TESTED CHANNEL	MODULATION TECHNOLOGY	MODULATION TYPE	DATA RATE (Mbps)
-	802.11b	1 to 11	1, 6, 11	DSSS	DBPSK	1.0
-	802.11g	1 to 11	1, 6, 11	OFDM	BPSK	6.0
-	802.11n (HT20)	1 to 11	1, 6, 11	OFDM	BPSK	6.5
-	802.11n (HT40)	3 to 9	3, 6, 9	OFDM	BPSK	13.5

Test Condition:

APPLICABLE TO	ENVIRONMENTAL CONDITIONS	INPUT POWER	TESTED BY
RE\geq1G	26deg. C, 72%RH	120Vac, 60Hz	Aaron You
RE$<$1G	26deg. C, 71%RH	120Vac, 60Hz	Aaron You
PLC	26deg. C, 71%RH	120Vac, 60Hz	Aaron You
APCM	25deg. C, 60%RH	120Vac, 60Hz	Saxon Lee

3.3 Duty Cycle of Test Signal

If duty cycle of test signal is 100 %, duty factor is not required.
 If duty cycle of test signal is < 98%, duty factor shall be considered.

802.11b: Duty cycle of test signal is 100 %.

802.11g: Duty cycle = $2.043/2.231 = 0.916$, Duty factor = $10 * \log(1/0.916) = 0.38$

802.11n (HT20): Duty cycle = $1.898/2.043 = 0.929$, Duty factor = $10 * \log(1/0.929) = 0.33$

802.11n (HT40): Duty cycle = $0.898/1.115 = 0.805$, Duty factor = $10 * \log(1/0.805) = 0.94$

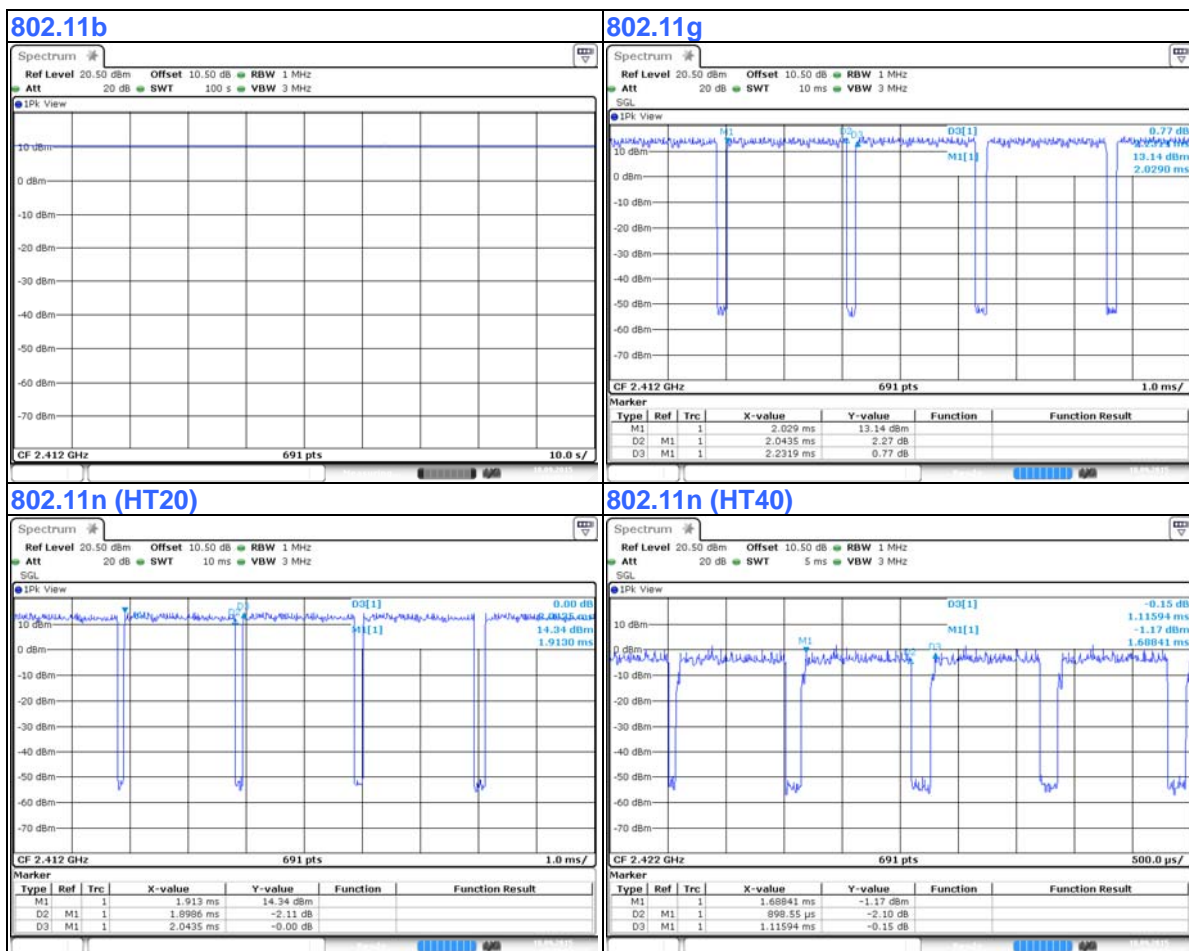



3.4 Description of Support Units

The EUT has been tested as an independent unit together with other necessary accessories or support units. The following support units or accessories were used to form a representative test configuration during the tests.

ID	Product	Brand	Model No.	Serial No.	FCC ID	Remarks
A.	USB 3.0 Flash Drive	HP	v250w	N/A	FCC DoC Approved	Provided by Lab
	USB 3.0 Flash Drive	HP	v250w	N/A	FCC DoC Approved	Provided by Lab
B.	RJ11 Load	N/A	N/A	N/A	N/A	Provided by Lab
C.	LAN Load	N/A	N/A	N/A	N/A	Provided by Lab
D.	Notebook PC	DELL	510m	1KZ1G1S	FCC DoC Approved	Provided by Lab
E.	Notebook PC	DELL	E5410	BW33YM1	FCC DoC Approved	Provided by Lab
F.	Notebook PC	DELL	PP27L	8SNZ12S	FCC DoC Approved	Provided by Lab
G.	Notebook PC	DELL	E6530	9331GV1	FCC DoC Approved	Provided by Lab

Note:

1. All power cords of the above support units are non-shielded (1.8m).
2. Items D~G acted as communication partners to transfer data.

ID	Descriptions	Qty.	Length (m)	Shielding (Yes/No)	Cores (Qty.)	Remarks
1.	LAN cable	3	1.8	N	0	Provided by Lab
2.	RJ11 cable	1	1.8	N	0	Provided by Lab
3.	DC cable	1	1.2	N	0	Supplied by client
4.	LAN cable	1	10	N	0	Provided by Lab
5.	LAN cable	1	10	N	0	Provided by Lab

Note: The core(s) is(are) originally attached to the cable(s).

3.4.1 Configuration of System under Test

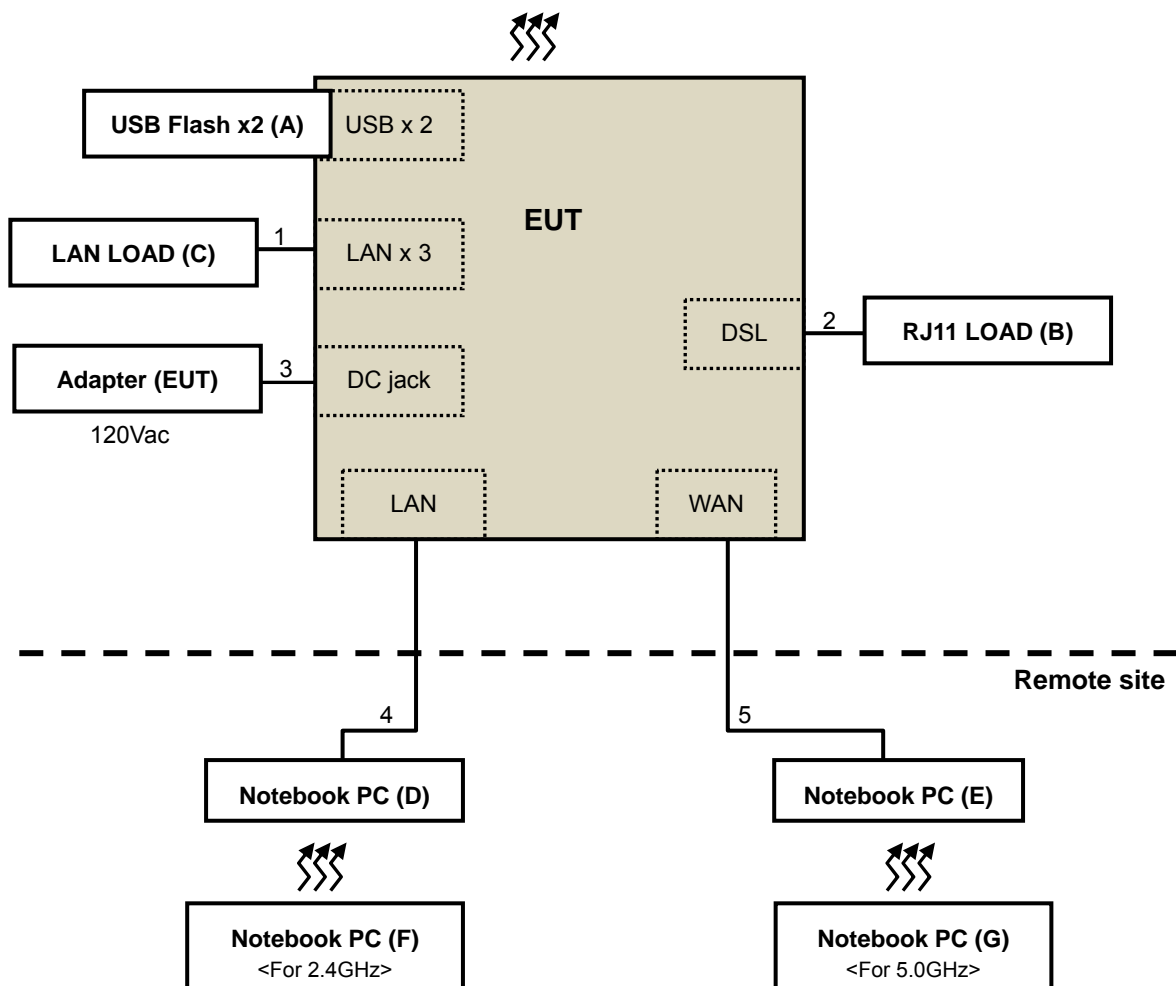

3.5 General Description of Applied Standards

The EUT is a RF Product. According to the specifications of the manufacturer, it must comply with the requirements of the following standards:

FCC Part 15, Subpart C (15.247)

558074 D01 DTS Meas Guidance v03r03

662911 D01 Multiple Transmitter Output v02r01

ANSI C63.10-2013

All test items have been performed and recorded as per the above standards.

NOTE: The EUT has been verified to comply with the requirements of FCC Part 15, Subpart B, Class B (DoC). The test report has been issued separately.

4 Test Types and Results

4.1 Radiated Emission and Bandedge Measurement

4.1.1 Limits of Radiated Emission and Bandedge Measurement

Radiated emissions which fall in the restricted bands must comply with the radiated emission limits specified as below table. Other emissions shall be at least 20dB below the highest level of the desired power:

Frequencies (MHz)	Field Strength (microvolts/meter)	Measurement Distance (meters)
0.009 ~ 0.490	2400/F(kHz)	300
0.490 ~ 1.705	24000/F(kHz)	30
1.705 ~ 30.0	30	30
30 ~ 88	100	3
88 ~ 216	150	3
216 ~ 960	200	3
Above 960	500	3

NOTE:

1. The lower limit shall apply at the transition frequencies.
2. Emission level (dBuV/m) = 20 log Emission level (uV/m).
3. For frequencies above 1000MHz, the field strength limits are based on average detector, however, the peak field strength of any emission shall not exceed the maximum permitted average limits, specified above by more than 20dB under any condition of modulation.



4.1.2 Test Instruments

DESCRIPTION & MANUFACTURER	MODEL NO.	SERIAL NO.	CALIBRATED DATE	CALIBRATED UNTIL
HP Preamplifier	8447D	2432A03504	Feb. 26, 2015	Feb. 25, 2016
HP Preamplifier	8449B	3008A01201	Feb. 26, 2015	Feb. 25, 2016
MITEQ Preamplifier	AMF-6F-260400-33-8P	892164	Mar. 01, 2015	Feb. 28, 2016
Agilent Spectrum	E4446A	MY51100050	Oct. 24, 2014	Oct. 23, 2015
Agilent TEST RECEIVER	N9038A	MY51210129	Jan. 20, 2015	Jan. 19, 2016
Schwarzbeck Antenna	VULB 9168	139	Feb. 04, 2015	Feb. 03, 2016
Schwarzbeck Antenna	VHBA 9123	480	May 29, 2015	May 28, 2017
Schwarzbeck Horn Antenna	BBHA-9170	212	Feb. 09, 2015	Feb. 08, 2016
Schwarzbeck Horn Antenna	BBHA 9120-D1	D130	Feb. 10, 2015	Feb. 09, 2016
ADT. Turn Table	TT100	0306	NA	NA
ADT. Tower	AT100	0306	NA	NA
Software	Radiated_V7.6.15.9.4	NA	NA	NA
SUHNER RF cable With 4dB PAD	SF104	CABLE-CH6	Aug. 15, 2015	Aug. 14, 2016
SUHNER RF cable With 3dB PAD	SF102	Cable-CH8-3.6m	Aug. 15, 2015	Aug. 14, 2016
EMCO Horn Antenna	3115	00028257	Feb. 05, 2015	Feb. 04, 2016
Highpass filter Wainwright Instruments	WHK 3.1/18G-10SS	SN 8	NA	NA
ROHDE & SCHWARZ Spectrum Analyzer	FSV40	101042	Sep. 23, 2015	Sep. 22, 2016
Anritsu Power Sensor	MA2411B	0738404	Apr. 21, 2015	Apr. 20, 2016
Anritsu Power Meter	ML2495A	0842014	Apr. 21, 2015	Apr. 20, 2016

- NOTE:**
1. The calibration interval of the above test instruments is 12/24 months. And the calibrations are traceable to NML/ROC and NIST/USA.
 2. The horn antenna and HP preamplifier (model: 8449B) are used only for the measurement of emission frequency above 1GHz if tested.
 3. The test was performed in Chamber No. 6.
 4. The Industry Canada Reference No. IC 7450E-6.
 5. The FCC Site Registration No. is 447212.

4.1.3 Test Procedures

- a. The EUT was placed on the top of a rotating table 0.8 meters (for below 1GHz) / 1.5 meters (for above 1GHz) above the ground at 3 meter chamber room for test. The table was rotated 360 degrees to determine the position of the highest radiation.
- b. The EUT was set 3 meters away from the interference-receiving antenna, which was mounted on the top of a variable-height antenna tower.
- c. The height of antenna is varied from one meter to four meters above the ground to determine the maximum value of the field strength. Both horizontal and vertical polarizations of the antenna are set to make the measurement.
- d. For each suspected emission, the EUT was arranged to its worst case and then the antenna was tuned to heights from 1 meter to 4 meters and the rotatable table was turned from 0 degrees to 360 degrees to find the maximum reading.
- e. The test-receiver system was set to quasi-peak detect function and specified bandwidth with maximum hold mode when the test frequency is below 1 GHz.
- f. The test-receiver system was set to peak and average detect function and specified bandwidth with maximum hold mode when the test frequency is above 1 GHz. If the peak reading value also meets average limit, measurement with the average detector is unnecessary.

Note:

1. The resolution bandwidth and video bandwidth of test receiver/spectrum analyzer is 120kHz for Quasi-peak detection (QP) at frequency below 1GHz.
2. The resolution bandwidth of test receiver/spectrum analyzer is 1 MHz and the video bandwidth is 3 MHz for Peak detection (PK) at frequency above 1GHz.
3. The resolution bandwidth of test receiver/spectrum analyzer is 1MHz and the video bandwidth is 3MHz for RMS Average (Duty cycle < 98%) for Average detection (AV) at frequency above 1GHz, then the measurement results was added to a correction factor ($10 \log(1/\text{duty cycle})$).
4. The resolution bandwidth of test receiver/spectrum analyzer is 1MHz and the video bandwidth is 10Hz (Duty cycle $\geq 98\%$) for Average detection (AV) at frequency above 1GHz.
5. All modes of operation were investigated and the worst-case emissions are reported.

4.1.4 Deviation from Test Standard

No deviation.

4.1.5 Test Set Up

<Frequency Range below 1GHz>

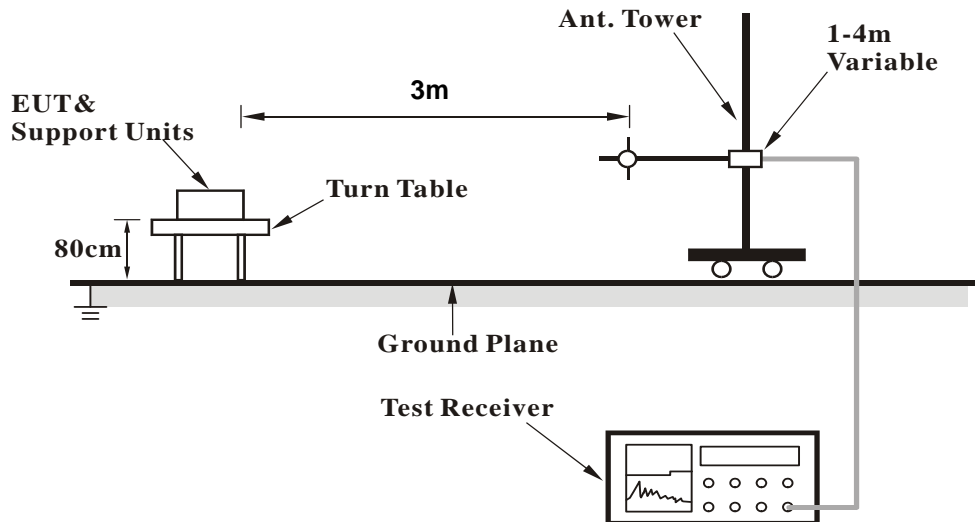

<Frequency Range above 1GHz>

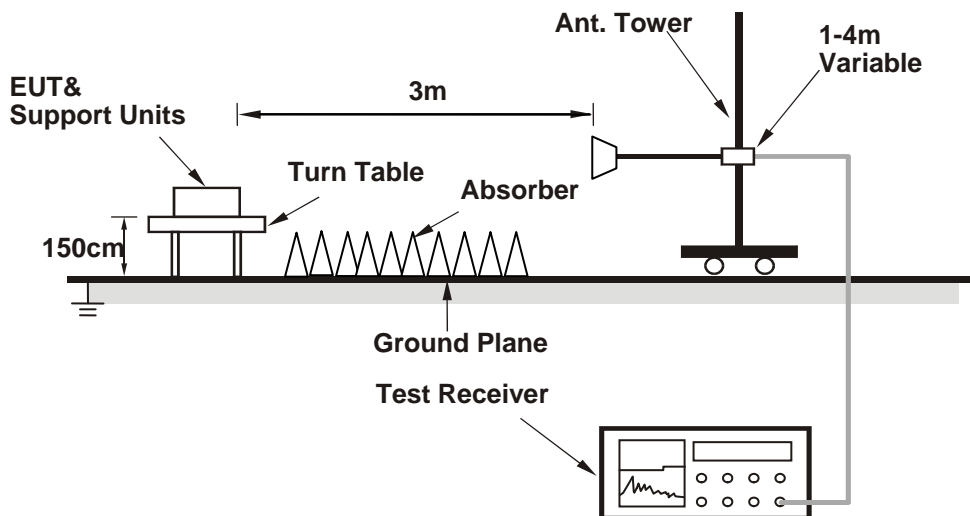

For the actual test configuration, please refer to the attached file (Test Setup Photo).

4.1.6 EUT Operating Conditions

- Placed the EUT on the testing table.
- Prepared notebook to act as communication partner and placed it outside of testing area.
- The communication partner connected with EUT via a RJ45 cable and ran a test program (provided by manufacturer) to enable EUT under transmission condition continuously at specific channel frequency.
- The communication partner sent data to EUT by command "PING".
- The necessary accessories enable the system in full functions.

4.1.7 Test Results

BELOW 1GHZ WORST-CASE DATA
802.11n (HT20)

CHANNEL	TX Channel 6	DETECTOR FUNCTION	Quasi-Peak (QP)
FREQUENCY RANGE	30MHz ~ 1GHz		

ANTENNA POLARITY & TEST DISTANCE: HORIZONTAL AT 3 M								
NO.	FREQ. (MHz)	EMISSION LEVEL (dBuV/m)	LIMIT (dBuV/m)	MARGIN (dB)	ANTENNA HEIGHT (m)	TABLE ANGLE (Degree)	RAW VALUE (dBuV)	CORRECTION FACTOR (dB/m)
1	61.04	24.8 QP	40.0	-15.2	4.00 H	169	34.22	-9.40
2	152.85	36.1 QP	43.5	-7.4	3.27 H	111	44.57	-8.45
3	223.51	35.2 QP	46.0	-10.8	3.05 H	153	46.28	-11.05
4	750.03	34.3 QP	46.0	-11.7	1.43 H	141	32.44	1.88
5	787.52	35.1 QP	46.0	-10.9	1.33 H	139	32.56	2.51
6	972.65	34.8 QP	54.0	-19.2	1.00 H	26	28.97	5.81
ANTENNA POLARITY & TEST DISTANCE: VERTICAL AT 3 M								
NO.	FREQ. (MHz)	EMISSION LEVEL (dBuV/m)	LIMIT (dBuV/m)	MARGIN (dB)	ANTENNA HEIGHT (m)	TABLE ANGLE (Degree)	RAW VALUE (dBuV)	CORRECTION FACTOR (dB/m)
1	37.13	33.4 QP	40.0	-6.6	1.46 V	263	43.25	-9.88
2	59.97	33.9 QP	40.0	-6.1	1.06 V	227	42.86	-9.00
3	162.36	28.5 QP	43.5	-15.0	1.00 V	183	36.94	-8.47
4	279.82	27.6 QP	46.0	-18.5	1.93 V	189	34.85	-7.30
5	562.53	31.5 QP	46.0	-14.5	2.67 V	263	32.95	-1.48
6	939.33	33.9 QP	46.0	-12.1	1.88 V	213	28.78	5.10

REMARKS:

1. Emission Level(dBuV/m) = Raw Value(dBuV) + Correction Factor(dB/m)
2. Correction Factor(dB/m) = Antenna Factor(dB/m) + Cable Factor(dB) – Pre-Amplifier Factor(dB)
3. The other emission levels were very low against the limit.
4. Margin value = Emission Level – Limit value



ABOVE 1GHz DATA

802.11b

CHANNEL	TX Channel 1	DETECTOR FUNCTION	Peak (PK)
FREQUENCY RANGE	1GHz ~ 25GHz		Average (AV)

ANTENNA POLARITY & TEST DISTANCE: HORIZONTAL AT 3 M

NO.	FREQ. (MHz)	EMISSION LEVEL (dBuV/m)	LIMIT (dBuV/m)	MARGIN (dB)	ANTENNA HEIGHT (m)	TABLE ANGLE (Degree)	RAW VALUE (dBuV)	CORRECTION FACTOR (dB/m)
1	2390.00	57.4 PK	74.0	-16.6	1.00 H	121	56.92	0.52
2	2390.00	41.5 AV	54.0	-12.5	1.00 H	121	41.02	0.52
3	*2412.00	89.9 PK			1.00 H	121	89.29	0.65
4	*2412.00	87.2 AV			1.00 H	121	86.57	0.65
5	4824.00	47.2 PK	74.0	-26.8	1.94 H	329	39.38	7.83
6	4824.00	38.5 AV	54.0	-15.5	1.94 H	329	30.67	7.83

ANTENNA POLARITY & TEST DISTANCE: VERTICAL AT 3 M

NO.	FREQ. (MHz)	EMISSION LEVEL (dBuV/m)	LIMIT (dBuV/m)	MARGIN (dB)	ANTENNA HEIGHT (m)	TABLE ANGLE (Degree)	RAW VALUE (dBuV)	CORRECTION FACTOR (dB/m)
1	2390.00	72.8 PK	74.0	-1.2	1.69 V	74	72.25	0.52
2	2390.00	48.8 AV	54.0	-5.2	1.69 V	74	48.31	0.52
3	*2412.00	106.6 PK			1.69 V	74	105.91	0.65
4	*2412.00	103.2 AV			1.69 V	74	102.58	0.65
5	4824.00	55.3 PK	74.0	-18.7	1.90 V	225	47.48	7.83
6	4824.00	44.5 AV	54.0	-9.5	1.90 V	225	36.68	7.83

REMARKS:

1. Emission Level(dBuV/m) = Raw Value(dBuV) + Correction Factor(dB/m)
2. Correction Factor(dB/m) = Antenna Factor(dB/m) + Cable Factor(dB) – Pre-Amplifier Factor(dB)
3. The other emission levels were very low against the limit.
4. Margin value = Emission Level – Limit value
5. " * ": Fundamental frequency.

CHANNEL	TX Channel 6	DETECTOR FUNCTION	Peak (PK)
FREQUENCY RANGE	1GHz ~ 25GHz		Average (AV)

ANTENNA POLARITY & TEST DISTANCE: HORIZONTAL AT 3 M

NO.	FREQ. (MHz)	EMISSION LEVEL (dBuV/m)	LIMIT (dBuV/m)	MARGIN (dB)	ANTENNA HEIGHT (m)	TABLE ANGLE (Degree)	RAW VALUE (dBuV)	CORRECTION FACTOR (dB/m)
1	*2437.00	95.3 PK			1.17 H	66	94.57	0.76
2	*2437.00	90.9 AV			1.17 H	66	90.10	0.76
3	4874.00	51.8 PK	74.0	-22.2	1.88 H	320	43.89	7.93
4	4874.00	43.6 AV	54.0	-10.5	1.88 H	320	35.62	7.93

ANTENNA POLARITY & TEST DISTANCE: VERTICAL AT 3 M

NO.	FREQ. (MHz)	EMISSION LEVEL (dBuV/m)	LIMIT (dBuV/m)	MARGIN (dB)	ANTENNA HEIGHT (m)	TABLE ANGLE (Degree)	RAW VALUE (dBuV)	CORRECTION FACTOR (dB/m)
1	*2437.00	110.2 PK			1.82 V	174	109.47	0.76
2	*2437.00	106.0 AV			1.82 V	174	105.19	0.76
3	4874.00	61.8 PK	74.0	-12.2	1.62 V	225	53.85	7.93
4	4874.00	52.8 AV	54.0	-1.2	1.62 V	225	44.83	7.93

REMARKS:

1. Emission Level(dBuV/m) = Raw Value(dBuV) + Correction Factor(dB/m)
2. Correction Factor(dB/m) = Antenna Factor(dB/m) + Cable Factor(dB) – Pre-Amplifier Factor(dB)
3. The other emission levels were very low against the limit.
4. Margin value = Emission Level – Limit value
5. " * ": Fundamental frequency.



CHANNEL	TX Channel 11	DETECTOR FUNCTION	Peak (PK)
FREQUENCY RANGE	1GHz ~ 25GHz		Average (AV)

ANTENNA POLARITY & TEST DISTANCE: HORIZONTAL AT 3 M								
NO.	FREQ. (MHz)	EMISSION LEVEL (dBuV/m)	LIMIT (dBuV/m)	MARGIN (dB)	ANTENNA HEIGHT (m)	TABLE ANGLE (Degree)	RAW VALUE (dBuV)	CORRECTION FACTOR (dB/m)
1	*2462.00	90.8 PK			1.17 H	65	89.93	0.88
2	*2462.00	87.1 AV			1.17 H	65	86.25	0.88
3	2483.50	56.3 PK	74.0	-17.7	1.17 H	65	55.35	0.98
4	2483.50	41.8 AV	54.0	-12.2	1.17 H	65	40.83	0.98
5	4924.00	50.9 PK	74.0	-23.1	1.90 H	334	42.83	8.08
6	4924.00	38.4 AV	54.0	-15.7	1.90 H	334	30.27	8.08
ANTENNA POLARITY & TEST DISTANCE: VERTICAL AT 3 M								
NO.	FREQ. (MHz)	EMISSION LEVEL (dBuV/m)	LIMIT (dBuV/m)	MARGIN (dB)	ANTENNA HEIGHT (m)	TABLE ANGLE (Degree)	RAW VALUE (dBuV)	CORRECTION FACTOR (dB/m)
1	*2462.00	107.2 PK			1.89 V	176	106.31	0.88
2	*2462.00	102.2 AV			1.89 V	176	101.33	0.88
3	2483.50	72.9 PK	74.0	-1.1	1.89 V	176	71.94	0.98
4	2483.50	51.7 AV	54.0	-2.3	1.89 V	176	50.74	0.98
5	4924.00	56.0 PK	74.0	-18.0	1.71 V	31	47.95	8.08
6	4924.00	44.3 AV	54.0	-9.7	1.71 V	31	36.23	8.08

REMARKS:

- Emission Level(dBuV/m) = Raw Value(dBuV) + Correction Factor(dB/m)
- Correction Factor(dB/m) = Antenna Factor(dB/m) + Cable Factor(dB) – Pre-Amplifier Factor(dB)
- The other emission levels were very low against the limit.
- Margin value = Emission Level – Limit value
- " * ": Fundamental frequency.

802.11g

CHANNEL	TX Channel 1	DETECTOR FUNCTION	Peak (PK)
FREQUENCY RANGE	1GHz ~ 25GHz		Average (AV)

ANTENNA POLARITY & TEST DISTANCE: HORIZONTAL AT 3 M

NO.	FREQ. (MHz)	EMISSION LEVEL (dBuV/m)	LIMIT (dBuV/m)	MARGIN (dB)	ANTENNA HEIGHT (m)	TABLE ANGLE (Degree)	RAW VALUE (dBuV)	CORRECTION FACTOR (dB/m)
1	2390.00	56.7 PK	74.0	-17.4	1.00 H	122	56.13	0.52
2	2390.00	42.5 AV	54.0	-11.5	1.00 H	122	41.96	0.52
3	*2412.00	98.7 PK			1.00 H	122	98.04	0.65
4	*2412.00	89.4 AV			1.00 H	122	88.71	0.65
5	4824.00	48.6 PK	74.0	-25.4	1.48 H	82	40.74	7.83
6	4824.00	37.6 AV	54.0	-16.4	1.48 H	82	29.77	7.83

ANTENNA POLARITY & TEST DISTANCE: VERTICAL AT 3 M

NO.	FREQ. (MHz)	EMISSION LEVEL (dBuV/m)	LIMIT (dBuV/m)	MARGIN (dB)	ANTENNA HEIGHT (m)	TABLE ANGLE (Degree)	RAW VALUE (dBuV)	CORRECTION FACTOR (dB/m)
1	2390.00	72.8 PK	74.0	-1.2	1.94 V	187	72.31	0.52
2	2390.00	52.6 AV	54.0	-1.4	1.94 V	187	52.11	0.52
3	*2412.00	116.1 PK			1.94 V	187	115.41	0.65
4	*2412.00	106.8 AV			1.94 V	187	106.13	0.65
5	4824.00	54.7 PK	74.0	-19.3	1.76 V	176	46.89	7.83
6	4824.00	41.7 AV	54.0	-12.3	1.76 V	176	33.91	7.83

REMARKS:

1. Emission Level(dBuV/m) = Raw Value(dBuV) + Correction Factor(dB/m)
2. Correction Factor(dB/m) = Antenna Factor(dB/m) + Cable Factor(dB) – Pre-Amplifier Factor(dB)
3. The other emission levels were very low against the limit.
4. Margin value = Emission Level – Limit value
5. " * ": Fundamental frequency.

CHANNEL	TX Channel 6	DETECTOR FUNCTION	Peak (PK)
FREQUENCY RANGE	1GHz ~ 25GHz		Average (AV)

ANTENNA POLARITY & TEST DISTANCE: HORIZONTAL AT 3 M								
---	--	--	--	--	--	--	--	--

NO.	FREQ. (MHz)	EMISSION LEVEL (dBuV/m)	LIMIT (dBuV/m)	MARGIN (dB)	ANTENNA HEIGHT (m)	TABLE ANGLE (Degree)	RAW VALUE (dBuV)	CORRECTION FACTOR (dB/m)
1	*2437.00	103.0 PK			1.17 H	66	102.19	0.76
2	*2437.00	94.4 AV			1.17 H	66	93.60	0.76
3	4874.00	51.0 PK	74.0	-23.0	1.33 H	81	43.06	7.93
4	4874.00	39.7 AV	54.0	-14.3	1.33 H	81	31.73	7.93

ANTENNA POLARITY & TEST DISTANCE: VERTICAL AT 3 M								
---	--	--	--	--	--	--	--	--

NO.	FREQ. (MHz)	EMISSION LEVEL (dBuV/m)	LIMIT (dBuV/m)	MARGIN (dB)	ANTENNA HEIGHT (m)	TABLE ANGLE (Degree)	RAW VALUE (dBuV)	CORRECTION FACTOR (dB/m)
1	*2437.00	118.1 PK			1.82 V	180	117.31	0.76
2	*2437.00	109.5 AV			1.82 V	180	108.73	0.76
3	4874.00	60.7 PK	74.0	-13.3	1.81 V	228	52.77	7.93
4	4874.00	47.1 AV	54.0	-6.9	1.81 V	228	39.14	7.93

REMARKS:

1. Emission Level(dBuV/m) = Raw Value(dBuV) + Correction Factor(dB/m)
2. Correction Factor(dB/m) = Antenna Factor(dB/m) + Cable Factor(dB) – Pre-Amplifier Factor(dB)
3. The other emission levels were very low against the limit.
4. Margin value = Emission Level – Limit value
5. " * ": Fundamental frequency.



CHANNEL	TX Channel 11	DETECTOR FUNCTION	Peak (PK)
FREQUENCY RANGE	1GHz ~ 25GHz		Average (AV)

ANTENNA POLARITY & TEST DISTANCE: HORIZONTAL AT 3 M

NO.	FREQ. (MHz)	EMISSION LEVEL (dBuV/m)	LIMIT (dBuV/m)	MARGIN (dB)	ANTENNA HEIGHT (m)	TABLE ANGLE (Degree)	RAW VALUE (dBuV)	CORRECTION FACTOR (dB/m)
1	*2462.00	96.4 PK			1.15 H	64	95.47	0.88
2	*2462.00	87.1 AV			1.15 H	64	86.18	0.88
3	2483.50	59.1 PK	74.0	-14.9	1.15 H	64	58.12	0.98
4	2483.50	42.0 AV	54.0	-12.0	1.15 H	64	41.03	0.98
5	4924.00	48.4 PK	74.0	-25.6	1.76 H	93	40.28	8.08
6	4924.00	37.9 AV	54.0	-16.2	1.76 H	93	29.77	8.08

ANTENNA POLARITY & TEST DISTANCE: VERTICAL AT 3 M

NO.	FREQ. (MHz)	EMISSION LEVEL (dBuV/m)	LIMIT (dBuV/m)	MARGIN (dB)	ANTENNA HEIGHT (m)	TABLE ANGLE (Degree)	RAW VALUE (dBuV)	CORRECTION FACTOR (dB/m)
1	*2462.00	114.2 PK			1.93 V	178	113.33	0.88
2	*2462.00	105.0 AV			1.93 V	178	104.12	0.88
3	2483.50	72.8 PK	74.0	-1.2	1.93 V	178	71.79	0.98
4	2483.50	48.9 AV	54.0	-5.1	1.93 V	178	47.88	0.98
5	4924.00	54.3 PK	74.0	-19.7	2.09 V	33	46.20	8.08
6	4924.00	40.6 AV	54.0	-13.4	2.09 V	33	32.53	8.08

REMARKS:

- Emission Level(dBuV/m) = Raw Value(dBuV) + Correction Factor(dB/m)
- Correction Factor(dB/m) = Antenna Factor(dB/m) + Cable Factor(dB) – Pre-Amplifier Factor(dB)
- The other emission levels were very low against the limit.
- Margin value = Emission Level – Limit value
- " * ": Fundamental frequency.

802.11n (HT20)

CHANNEL	TX Channel 1	DETECTOR FUNCTION	Peak (PK)
FREQUENCY RANGE	1GHz ~ 25GHz		Average (AV)

ANTENNA POLARITY & TEST DISTANCE: HORIZONTAL AT 3 M

NO.	FREQ. (MHz)	EMISSION LEVEL (dBuV/m)	LIMIT (dBuV/m)	MARGIN (dB)	ANTENNA HEIGHT (m)	TABLE ANGLE (Degree)	RAW VALUE (dBuV)	CORRECTION FACTOR (dB/m)
1	2390.00	55.6 PK	74.0	-18.4	1.00 H	122	55.09	0.52
2	2390.00	41.9 AV	54.0	-12.1	1.00 H	122	41.38	0.52
3	*2412.00	97.1 PK			1.00 H	122	96.44	0.65
4	*2412.00	87.2 AV			1.00 H	122	86.57	0.65
5	4824.00	48.1 PK	74.0	-25.9	1.82 H	73	40.26	7.83
6	4824.00	36.6 AV	54.0	-17.4	1.82 H	73	28.77	7.83

ANTENNA POLARITY & TEST DISTANCE: VERTICAL AT 3 M

NO.	FREQ. (MHz)	EMISSION LEVEL (dBuV/m)	LIMIT (dBuV/m)	MARGIN (dB)	ANTENNA HEIGHT (m)	TABLE ANGLE (Degree)	RAW VALUE (dBuV)	CORRECTION FACTOR (dB/m)
1	2390.00	72.7 PK	74.0	-1.3	1.90 V	193	72.17	0.52
2	2390.00	48.6 AV	54.0	-5.4	1.90 V	193	48.12	0.52
3	*2412.00	113.0 PK			1.90 V	193	112.37	0.65
4	*2412.00	103.2 AV			1.90 V	193	102.56	0.65
5	4824.00	51.9 PK	74.0	-22.1	1.95 V	178	44.09	7.83
6	4824.00	38.4 AV	54.0	-15.7	1.95 V	178	30.52	7.83

REMARKS:

- Emission Level(dBuV/m) = Raw Value(dBuV) + Correction Factor(dB/m)
- Correction Factor(dB/m) = Antenna Factor(dB/m) + Cable Factor(dB) – Pre-Amplifier Factor(dB)
- The other emission levels were very low against the limit.
- Margin value = Emission Level – Limit value
- " * ": Fundamental frequency.



CHANNEL	TX Channel 6	DETECTOR FUNCTION	Peak (PK)
FREQUENCY RANGE	1GHz ~ 25GHz		Average (AV)

ANTENNA POLARITY & TEST DISTANCE: HORIZONTAL AT 3 M

NO.	FREQ. (MHz)	EMISSION LEVEL (dBuV/m)	LIMIT (dBuV/m)	MARGIN (dB)	ANTENNA HEIGHT (m)	TABLE ANGLE (Degree)	RAW VALUE (dBuV)	CORRECTION FACTOR (dB/m)
1	*2437.00	103.7 PK			1.15 H	66	102.95	0.76
2	*2437.00	94.2 AV			1.15 H	66	93.39	0.76
3	4874.00	51.2 PK	74.0	-22.8	1.63 H	89	43.27	7.93
4	4874.00	38.6 AV	54.0	-15.4	1.63 H	89	30.69	7.93

ANTENNA POLARITY & TEST DISTANCE: VERTICAL AT 3 M

NO.	FREQ. (MHz)	EMISSION LEVEL (dBuV/m)	LIMIT (dBuV/m)	MARGIN (dB)	ANTENNA HEIGHT (m)	TABLE ANGLE (Degree)	RAW VALUE (dBuV)	CORRECTION FACTOR (dB/m)
1	*2437.00	117.9 PK			1.93 V	187	117.13	0.76
2	*2437.00	108.3 AV			1.93 V	187	107.54	0.76
3	4874.00	62.1 PK	74.0	-11.9	1.98 V	250	54.15	7.93
4	4874.00	45.8 AV	54.0	-8.2	1.98 V	250	37.86	7.93

REMARKS:

1. Emission Level(dBuV/m) = Raw Value(dBuV) + Correction Factor(dB/m)
2. Correction Factor(dB/m) = Antenna Factor(dB/m) + Cable Factor(dB) – Pre-Amplifier Factor(dB)
3. The other emission levels were very low against the limit.
4. Margin value = Emission Level – Limit value
5. " * ": Fundamental frequency.



CHANNEL	TX Channel 11	DETECTOR FUNCTION	Peak (PK)
FREQUENCY RANGE	1GHz ~ 25GHz		Average (AV)

ANTENNA POLARITY & TEST DISTANCE: HORIZONTAL AT 3 M

NO.	FREQ. (MHz)	EMISSION LEVEL (dBuV/m)	LIMIT (dBuV/m)	MARGIN (dB)	ANTENNA HEIGHT (m)	TABLE ANGLE (Degree)	RAW VALUE (dBuV)	CORRECTION FACTOR (dB/m)
1	*2462.00	96.5 PK			1.17 H	66	95.62	0.88
2	*2462.00	87.1 AV			1.17 H	66	86.17	0.88
3	2483.50	55.8 PK	74.0	-18.2	1.17 H	66	54.86	0.98
4	2483.50	42.0 AV	54.0	-12.1	1.17 H	66	40.97	0.98
5	4924.00	48.3 PK	74.0	-25.8	1.68 H	103	40.17	8.08
6	4924.00	37.3 AV	54.0	-16.7	1.68 H	103	29.19	8.08

ANTENNA POLARITY & TEST DISTANCE: VERTICAL AT 3 M

NO.	FREQ. (MHz)	EMISSION LEVEL (dBuV/m)	LIMIT (dBuV/m)	MARGIN (dB)	ANTENNA HEIGHT (m)	TABLE ANGLE (Degree)	RAW VALUE (dBuV)	CORRECTION FACTOR (dB/m)
1	*2462.00	112.6 PK			2.08 V	187	111.67	0.88
2	*2462.00	102.9 AV			2.08 V	187	101.97	0.88
3	2483.50	72.6 PK	74.0	-1.4	2.08 V	187	71.62	0.98
4	2483.50	47.6 AV	54.0	-6.4	2.08 V	187	46.65	0.98
5	4924.00	51.0 PK	74.0	-23.0	1.96 V	49	42.89	8.08
6	4924.00	38.9 AV	54.0	-15.1	1.96 V	49	30.81	8.08

REMARKS:

1. Emission Level(dBuV/m) = Raw Value(dBuV) + Correction Factor(dB/m)
2. Correction Factor(dB/m) = Antenna Factor(dB/m) + Cable Factor(dB) – Pre-Amplifier Factor(dB)
3. The other emission levels were very low against the limit.
4. Margin value = Emission Level – Limit value
5. " * " : Fundamental frequency.

802.11n (HT40)

CHANNEL	TX Channel 3	DETECTOR FUNCTION	Peak (PK)
FREQUENCY RANGE	1GHz ~ 25GHz		Average (AV)

ANTENNA POLARITY & TEST DISTANCE: HORIZONTAL AT 3 M

NO.	FREQ. (MHz)	EMISSION LEVEL (dBuV/m)	LIMIT (dBuV/m)	MARGIN (dB)	ANTENNA HEIGHT (m)	TABLE ANGLE (Degree)	RAW VALUE (dBuV)	CORRECTION FACTOR (dB/m)
1	2390.00	56.8 PK	74.0	-17.2	1.19 H	65	56.28	0.52
2	2390.00	41.6 AV	54.0	-12.4	1.19 H	65	41.05	0.52
3	*2422.00	87.3 PK			1.19 H	65	86.63	0.69
4	*2422.00	77.4 AV			1.19 H	65	76.73	0.69
5	4844.00	47.9 PK	74.0	-26.1	1.57 H	93	40.06	7.87
6	4844.00	35.0 AV	54.0	-19.0	1.57 H	93	27.15	7.87

ANTENNA POLARITY & TEST DISTANCE: VERTICAL AT 3 M

NO.	FREQ. (MHz)	EMISSION LEVEL (dBuV/m)	LIMIT (dBuV/m)	MARGIN (dB)	ANTENNA HEIGHT (m)	TABLE ANGLE (Degree)	RAW VALUE (dBuV)	CORRECTION FACTOR (dB/m)
1	2390.00	72.3 PK	74.0	-1.8	1.74 V	194	71.73	0.52
2	2390.00	43.2 AV	54.0	-10.9	1.74 V	194	42.63	0.52
3	*2422.00	102.2 PK			1.74 V	194	101.53	0.69
4	*2422.00	91.6 AV			1.74 V	194	90.86	0.69
5	4844.00	49.2 PK	74.0	-24.9	1.47 V	305	41.28	7.87
6	4844.00	37.3 AV	54.0	-16.7	1.47 V	305	29.44	7.87

REMARKS:

1. Emission Level(dBuV/m) = Raw Value(dBuV) + Correction Factor(dB/m)
2. Correction Factor(dB/m) = Antenna Factor(dB/m) + Cable Factor(dB) – Pre-Amplifier Factor(dB)
3. The other emission levels were very low against the limit.
4. Margin value = Emission Level – Limit value
5. " * ": Fundamental frequency.

CHANNEL	TX Channel 6	DETECTOR FUNCTION	Peak (PK)
FREQUENCY RANGE	1GHz ~ 25GHz		Average (AV)

ANTENNA POLARITY & TEST DISTANCE: HORIZONTAL AT 3 M

NO.	FREQ. (MHz)	EMISSION LEVEL (dBuV/m)	LIMIT (dBuV/m)	MARGIN (dB)	ANTENNA HEIGHT (m)	TABLE ANGLE (Degree)	RAW VALUE (dBuV)	CORRECTION FACTOR (dB/m)
1	*2437.00	93.5 PK			1.16 H	66	92.75	0.76
2	*2437.00	84.0 AV			1.16 H	66	83.21	0.76
3	4874.00	49.6 PK	74.0	-24.4	1.69 H	78	41.68	7.93
4	4874.00	37.6 AV	54.0	-16.4	1.69 H	78	29.66	7.93

ANTENNA POLARITY & TEST DISTANCE: VERTICAL AT 3 M

NO.	FREQ. (MHz)	EMISSION LEVEL (dBuV/m)	LIMIT (dBuV/m)	MARGIN (dB)	ANTENNA HEIGHT (m)	TABLE ANGLE (Degree)	RAW VALUE (dBuV)	CORRECTION FACTOR (dB/m)
1	*2437.00	109.3 PK			1.86 V	185	108.53	0.76
2	*2437.00	98.3 AV			1.86 V	185	97.52	0.76
3	4874.00	56.4 PK	74.0	-17.6	1.53 V	176	48.48	7.93
4	4874.00	41.0 AV	54.0	-13.0	1.53 V	176	33.05	7.93

REMARKS:

1. Emission Level(dBuV/m) = Raw Value(dBuV) + Correction Factor(dB/m)
2. Correction Factor(dB/m) = Antenna Factor(dB/m) + Cable Factor(dB) – Pre-Amplifier Factor(dB)
3. The other emission levels were very low against the limit.
4. Margin value = Emission Level – Limit value
5. " * ": Fundamental frequency.



CHANNEL	TX Channel 9	DETECTOR FUNCTION	Peak (PK)
FREQUENCY RANGE	1GHz ~ 25GHz		Average (AV)

ANTENNA POLARITY & TEST DISTANCE: HORIZONTAL AT 3 M

NO.	FREQ. (MHz)	EMISSION LEVEL (dBuV/m)	LIMIT (dBuV/m)	MARGIN (dB)	ANTENNA HEIGHT (m)	TABLE ANGLE (Degree)	RAW VALUE (dBuV)	CORRECTION FACTOR (dB/m)
1	*2452.00	86.5 PK			1.15 H	64	85.64	0.83
2	*2452.00	76.6 AV			1.15 H	64	75.77	0.83
3	2483.50	56.2 PK	74.0	-17.8	1.15 H	65	55.26	0.98
4	2483.50	41.7 AV	54.0	-12.3	1.15 H	65	40.70	0.98
5	4904.00	47.8 PK	74.0	-26.2	1.49 H	107	39.84	8.00
6	4904.00	35.7 AV	54.0	-18.4	1.49 H	107	27.65	8.00

ANTENNA POLARITY & TEST DISTANCE: VERTICAL AT 3 M

NO.	FREQ. (MHz)	EMISSION LEVEL (dBuV/m)	LIMIT (dBuV/m)	MARGIN (dB)	ANTENNA HEIGHT (m)	TABLE ANGLE (Degree)	RAW VALUE (dBuV)	CORRECTION FACTOR (dB/m)
1	*2452.00	103.0 PK			1.94 V	186	102.15	0.83
2	*2452.00	92.6 AV			1.94 V	186	91.76	0.83
3	2483.50	72.5 PK	74.0	-1.5	1.94 V	184	71.53	0.98
4	2483.50	44.6 AV	54.0	-9.4	1.94 V	186	43.66	0.98
5	4904.00	48.9 PK	74.0	-25.1	1.86 V	314	40.93	8.00
6	4904.00	36.0 AV	54.0	-18.0	1.86 V	314	28.01	8.00

REMARKS:

1. Emission Level(dBuV/m) = Raw Value(dBuV) + Correction Factor(dB/m)
2. Correction Factor(dB/m) = Antenna Factor(dB/m) + Cable Factor(dB) – Pre-Amplifier Factor(dB)
3. The other emission levels were very low against the limit.
4. Margin value = Emission Level – Limit value
5. " * " : Fundamental frequency.

4.2 Conducted Emission Measurement

4.2.1 Limits of Conducted Emission Measurement

Frequency (MHz)	Conducted Limit (dBuV)	
	Quasi-peak	Average
0.15 - 0.5	66 - 56	56 - 46
0.50 - 5.0	56	46
5.0 - 30.0	60	50

Note: 1. The lower limit shall apply at the transition frequencies.

2. The limit decreases in line with the logarithm of the frequency in the range of 0.15 to 0.50MHz.

4.2.2 Test Instruments

Description & Manufacturer	Model No.	Serial No.	Cal. Date	Cal. Due
ROHDE & SCHWARZ TEST RECEIVER	ESCS 30	100276	Apr. 01, 2015	Mar. 31, 2016
ROHDE & SCHWARZ Artificial Mains Network (for EUT)	ENV216	101197	Apr. 27, 2015	Apr. 26, 2016
LISN With Adapter (for EUT)	AD10	C10Ada-002	Apr. 27, 2015	Apr. 26, 2016
ROHDE & SCHWARZ Artificial Mains Network (for peripherals)	ESH3-Z5	100218	Nov. 25, 2014	Nov. 24, 2015
SCHWARZBECK Artificial Mains Network (For EUT)	NNLK8129	8129229	May 06, 2015	May 05, 2016
Software	Cond_V7.3.7	NA	NA	NA
RF cable (JYEBAO) With 10dB PAD	5D-FB	Cable-C10.01	Feb. 17, 2015	Feb. 16, 2016
SUHNER Terminator (For ROHDE & SCHWARZ LISN)	65BNC-5001	E1-011484	May 19, 2015	May 18, 2016
ROHDE & SCHWARZ Artificial Mains Network (For TV EUT)	ESH3-Z5	100220	Nov. 20, 2014	Nov. 19, 2015
LISN With Adapter (for TV EUT)	100220	N/A	Nov. 20, 2014	Nov. 19, 2015

Notes: 1. The calibration interval of the above test instruments is 12 months and the calibrations are traceable to NML/ROC and NIST/USA.

2. The test was performed in Shielded Room No. 10.

3. The VCCI Site Registration No. C-1852.

4.2.3 Test Procedures

- a. The EUT was placed 0.4 meters from the conducting wall of the shielded room with EUT being connected to the power mains through a line impedance stabilization network (LISN). Other support units were connected to the power mains through another LISN. The two LISNs provide 50 ohm/ 50uH of coupling impedance for the measuring instrument.
- b. Both lines of the power mains connected to the EUT were checked for maximum conducted interference.
- c. The frequency range from 150kHz to 30MHz was searched. Emission levels under (Limit - 20dB) was not recorded.

NOTE: The resolution bandwidth and video bandwidth of test receiver is 9kHz for quasi-peak detection (QP) and average detection (AV) at frequency 0.15MHz-30MHz.

4.2.4 Deviation from Test Standard

No deviation.

4.2.5 Test Setup

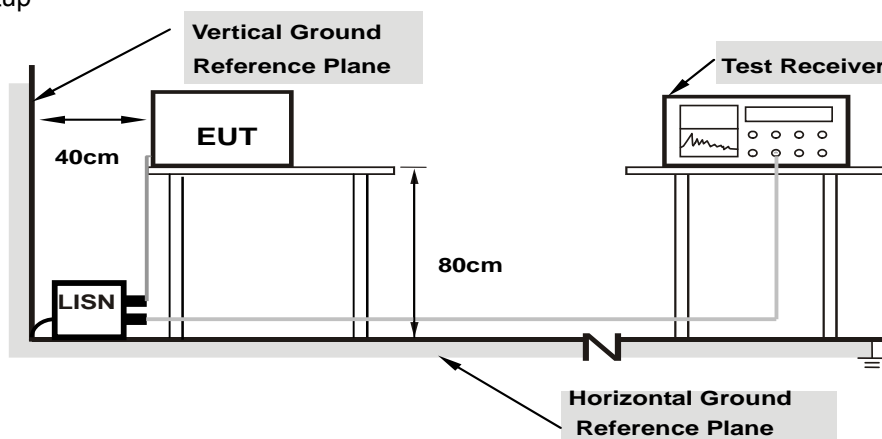

Note: 1.Support units were connected to second LISN.

For the actual test configuration, please refer to the attached file (Test Setup Photo).

4.2.6 EUT Operating Conditions

Same as 4.1.6.

4.2.7 Test Results

802.11n (HT20): CH 6

Phase	Line (L)	Detector Function	Quasi-Peak (QP) / Average (AV)
-------	----------	-------------------	--------------------------------

No	Frequency (MHz)	Correction Factor (dB)	Reading Value (dBuV)		Emission Level (dBuV)		Limit (dBuV)		Margin (dB)	
			Q.P.	AV.	Q.P.	AV.	Q.P.	AV.	Q.P.	AV.
1	0.15001	9.67	43.00	33.64	52.67	43.31	66.00	56.00	-13.33	-12.69
2	0.17344	9.67	36.66	29.81	46.33	39.48	64.79	54.79	-18.46	-15.31
3	0.22812	9.68	30.43	21.24	40.11	30.92	62.52	52.52	-22.41	-21.60
4	0.36484	9.69	30.84	23.95	40.53	33.64	58.62	48.62	-18.09	-14.98
5	4.57422	9.96	8.50	5.99	18.46	15.95	56.00	46.00	-37.54	-30.05
6	8.10938	10.03	19.84	14.56	29.87	24.59	60.00	50.00	-30.13	-25.41

Remarks:

1. Q.P. and AV. are abbreviations of quasi-peak and average individually.
2. The emission levels of other frequencies were very low against the limit.
3. Margin value = Emission level – Limit value
4. Correction factor = Insertion loss + Cable loss
5. Emission Level = Correction Factor + Reading Value

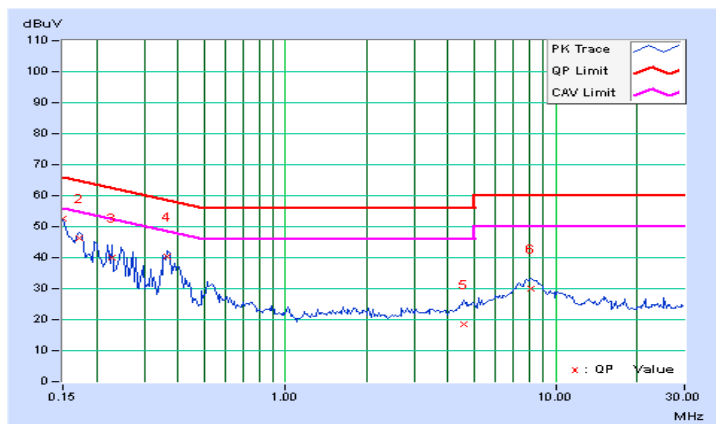

Phase	Neutral (N)	Detector Function	Quasi-Peak (QP) / Average (AV)
-------	-------------	-------------------	--------------------------------

No	Frequency (MHz)	Correction Factor (dB)	Reading Value (dBuV)		Emission Level (dBuV)		Limit (dBuV)		Margin (dB)	
			Q.P.	AV.	Q.P.	AV.	Q.P.	AV.	Q.P.	AV.
1	0.15001	9.72	42.57	32.94	52.29	42.66	66.00	56.00	-13.71	-13.34
2	0.16562	9.72	37.48	22.87	47.20	32.59	65.18	55.18	-17.97	-22.58
3	0.18906	9.73	31.11	17.80	40.84	27.53	64.08	54.08	-23.24	-26.55
4	0.38438	9.74	19.35	12.48	29.09	22.22	58.18	48.18	-29.10	-25.97
5	4.76563	10.00	9.13	4.04	19.13	14.04	56.00	46.00	-36.87	-31.96
6	7.97656	10.07	19.92	14.87	29.99	24.94	60.00	50.00	-30.01	-25.06

Remarks:

1. Q.P. and AV. are abbreviations of quasi-peak and average individually.
2. The emission levels of other frequencies were very low against the limit.
3. Margin value = Emission level – Limit value
4. Correction factor = Insertion loss + Cable loss
5. Emission Level = Correction Factor + Reading Value

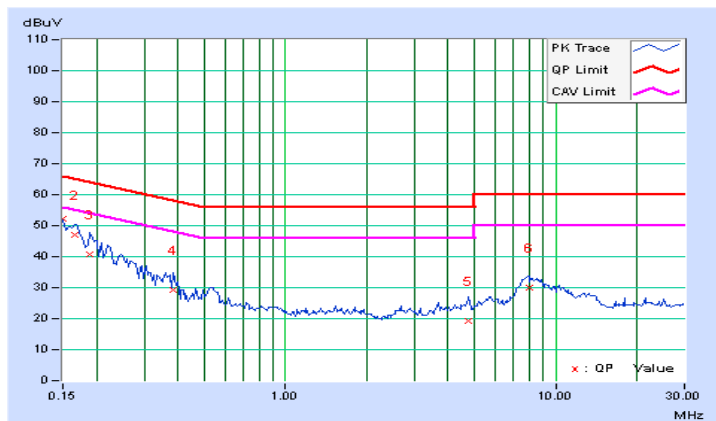

4.3 6dB Bandwidth Measurement

4.3.1 Limits of 6dB Bandwidth Measurement

The minimum of 6dB Bandwidth Measurement is 0.5 MHz.

4.3.2 Test Setup

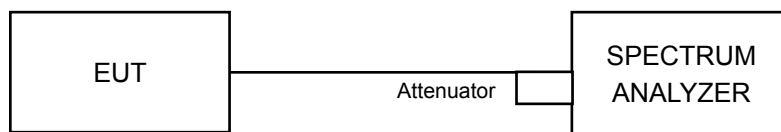

4.3.3 Test Instruments

Refer to section 4.1.2 to get information of above instrument.

4.3.4 Test Procedure

- a. Set resolution bandwidth (RBW) = 100kHz
- b. Set the video bandwidth (VBW) $\geq 3 \times$ RBW, Detector = Peak.
- c. Trace mode = max hold.
- d. Sweep = auto couple.
- e. Measure the maximum width of the emission that is constrained by the frequencies associated with the two amplitude points (upper and lower) that are attenuated by 6 dB relative to the maximum level measured in the fundamental emission

4.3.5 Deviation from Test Standard

No deviation.

4.3.6 EUT Operating Conditions

The software provided by client to enable the EUT under transmission condition continuously at lowest, middle and highest channel frequencies individually.

4.3.7 Test Result

802.11b

Channel	Frequency (MHz)	6db Bandwidth (MHz)		Minimum Limit (MHz)	Pass / Fail
		CHAIN 0	CHAIN 1		
1	2412	9.14	10.02	0.5	PASS
6	2437	9.58	9.58	0.5	PASS
11	2462	9.57	10.06	0.5	PASS

802.11g

Channel	Frequency (MHz)	6db Bandwidth (MHz)		Minimum Limit (MHz)	Pass / Fail
		CHAIN 0	CHAIN 1		
1	2412	16.38	16.37	0.5	PASS
6	2437	16.39	16.40	0.5	PASS
11	2462	16.38	16.39	0.5	PASS

802.11n (HT20)

Channel	Frequency (MHz)	6db Bandwidth (MHz)		Minimum Limit (MHz)	Pass / Fail
		CHAIN 0	CHAIN 1		
1	2412	17.60	17.62	0.5	Pass
6	2437	17.61	17.61	0.5	Pass
11	2462	17.61	17.60	0.5	Pass

802.11n (HT40)

Channel	Frequency (MHz)	6db Bandwidth (MHz)		Minimum Limit (MHz)	Pass / Fail
		CHAIN 0	CHAIN 1		
3	2422	35.84	35.69	0.5	Pass
6	2437	35.53	35.41	0.5	Pass
9	2452	35.50	35.41	0.5	Pass

Spectrum Plot of Worst Value

802.11b

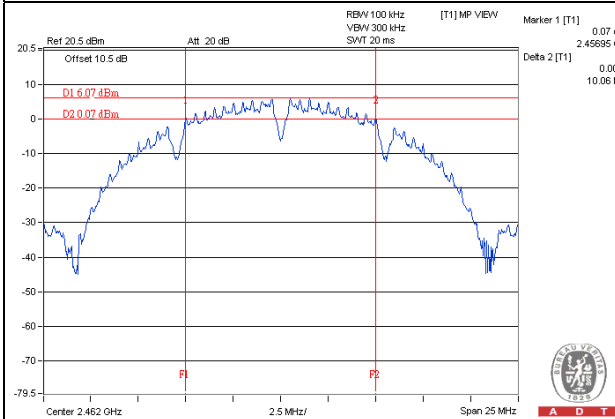

802.11g

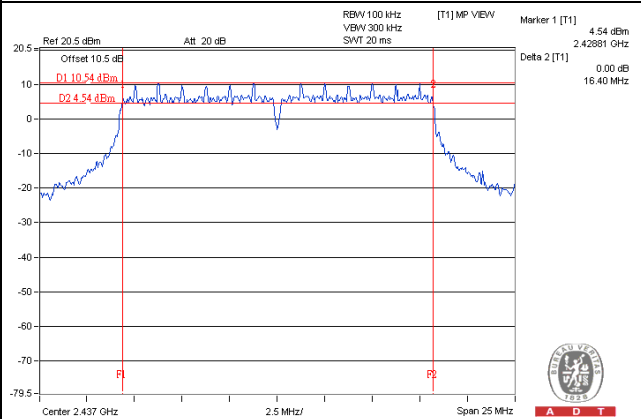

802.11n (HT20)

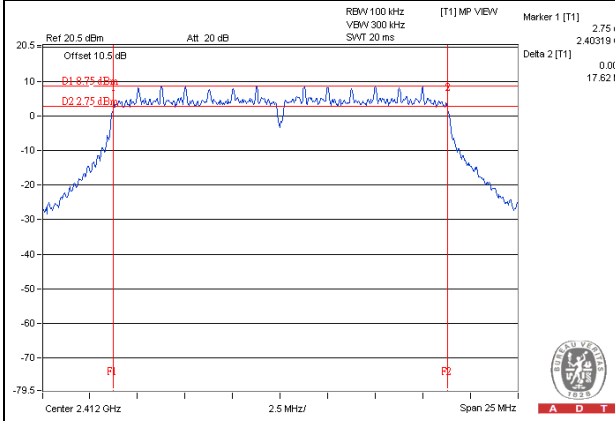

802.11n (HT40)

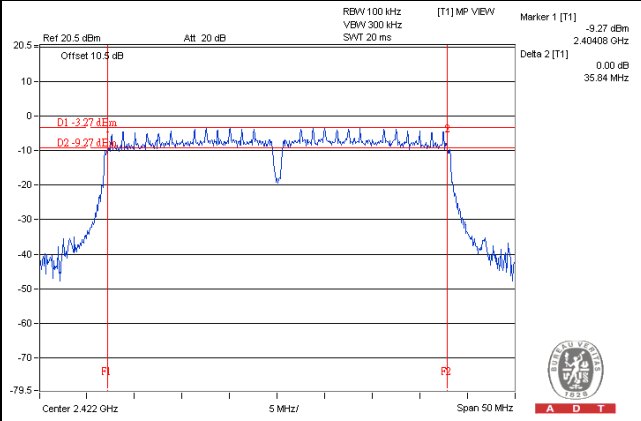

4.4 Conducted Output Power Measurement

4.4.1 Limits of Conducted Output Power Measurement

For systems using digital modulation in the 2400–2483.5 MHz bands: 1 Watt (30dBm)

Per KDB 662911 D01 Multiple Transmitter Output Method of conducted output power measurement on IEEE 802.11 devices,

Array Gain = 0 dB (i.e., no array gain) for $NANT \leq 4$;

Array Gain = 0 dB (i.e., no array gain) for channel widths ≥ 40 MHz for any NANT;

Array Gain = $5 \log(NANT/NSS)$ dB or 3 dB, whichever is less for 20-MHz channel widths with $NANT \geq 5$.

For power measurements on all other devices: Array Gain = $10 \log(NANT/NSS)$ dB.

4.4.2 Test Setup

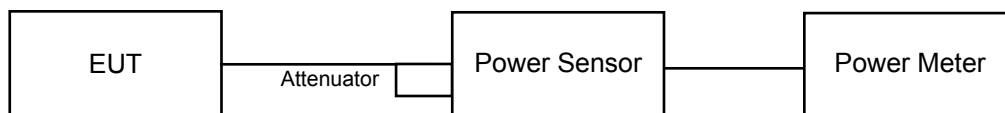

4.4.3 Test Instruments

Refer to section 4.1.2 to get information of above instrument.

4.4.4 Test Procedures

A peak / average power sensor was used on the output port of the EUT. A power meter was used to read the response of the peak / average power sensor. Record the power level.

4.4.5 Deviation from Test Standard

No deviation.

4.4.6 EUT Operating Conditions

Same as Item 4.3.6.

4.4.7 Test Results

FOR PEAK POWER

802.11b

Chan.	Freq. (MHz)	Peak Power (dBm)		Total Power (mW)	Total Power (dBm)	Limit (dBm)	Pass / Fail
		Chain 0	Chain 1				
1	2412	15.24	14.11	59.183	17.72	30	Pass
6	2437	19.01	18.73	154.261	21.88	30	Pass
11	2462	14.93	14.02	56.352	17.51	30	Pass

802.11g

Chan.	Freq. (MHz)	Peak Power (dBm)		Total Power (mW)	Total Power (dBm)	Limit (dBm)	Pass / Fail
		Chain 0	Chain 1				
1	2412	26.03	27.05	907.858	29.58	30	Pass
6	2437	26.12	27.01	911.604	29.60	30	Pass
11	2462	25.73	26.10	781.491	28.93	30	Pass

802.11n (HT20)

Chan.	Freq. (MHz)	Peak Power (dBm)		Total Power (mW)	Total Power (dBm)	Limit (dBm)	Pass / Fail
		Chain 0	Chain 1				
1	2412	26.54	26.23	870.576	29.40	30	Pass
6	2437	26.28	27.11	938.664	29.73	30	Pass
11	2462	24.42	24.65	568.437	27.55	30	Pass

802.11n (HT40)

Chan.	Freq. (MHz)	Peak Power (dBm)		Total Power (mW)	Total Power (dBm)	Limit (dBm)	Pass / Fail
		Chain 0	Chain 1				
3	2422	16.85	17.23	101.262	20.05	30	Pass
6	2437	24.23	24.01	516.618	27.13	30	Pass
9	2452	17.63	18.72	132.416	21.22	30	Pass

FOR AVERAGE POWER
802.11b

Chan.	Frequency (MHz)	Avg. Power (dBm)		Total Power (mW)	Total Power (dBm)
		Chain 0	Chain 1		
1	2412	13.03	12.07	36.197	15.59
6	2437	16.59	16.54	90.686	19.58
11	2462	12.51	12.13	34.155	15.33

802.11g

Chan.	Frequency (MHz)	Avg. Power (dBm)		Total Power (mW)	Total Power (dBm)
		Chain 0	Chain 1		
1	2412	19.38	19.87	183.747	22.64
6	2437	19.42	19.91	185.447	22.68
11	2462	16.72	17.28	100.445	20.02

802.11n (HT20)

Chan.	Frequency (MHz)	Avg. Power (dBm)		Total Power (mW)	Total Power (dBm)
		Chain 0	Chain 1		
1	2412	17.98	17.41	117.887	20.71
6	2437	19.39	19.85	183.501	22.64
11	2462	15.01	15.10	64.055	18.07

802.11n (HT40)

Chan.	Frequency (MHz)	Avg. Power (dBm)		Total Power (mW)	Total Power (dBm)
		Chain 0	Chain 1		
3	2422	8.72	8.07	13.859	11.42
6	2437	15.08	15.67	69.109	18.40
9	2452	8.94	9.01	15.796	11.99

4.5 Power Spectral Density Measurement

4.5.1 Limits of Power Spectral Density Measurement

The Maximum of Power Spectral Density Measurement is 8dBm.

4.5.2 Test Setup

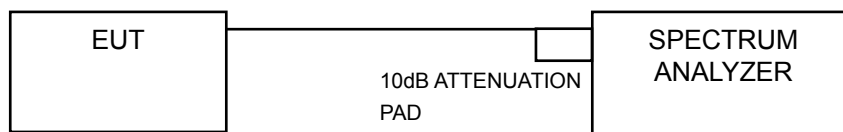

4.5.3 Test Instruments

Refer to section 4.1.2 to get information of above instrument.

4.5.4 Test Procedure

- a. Set analyzer center frequency to DTS channel center frequency.
- b. Set the span to 1.5 times the DTS bandwidth.
- c. Set the RBW to: $3 \text{ kHz} \leq \text{RBW} \leq 100 \text{ kHz}$.
- d. Set the VBW $\geq 3 \times \text{RBW}$.
- e. Detector = peak.
- f. Sweep time = auto couple.
- g. Trace mode = max hold.
- h. Allow trace to fully stabilize.
- i. Use the peak marker function to determine the maximum amplitude level within the RBW.

4.5.5 Deviation from Test Standard

No deviation.

4.5.6 EUT Operating Condition

Same as Item 4.3.6

4.5.7 Test Results

802.11b

TX chain	Channel	Freq. (MHz)	PSD (dBm)	10 log (N=2) dB	Total PSD (dBm)	Limit (dBm)	Pass /Fail
0	1	2412	0.83	3.01	3.84	7.99	Pass
	6	2437	4.37	3.01	7.38	7.99	Pass
	11	2462	0.84	3.01	3.85	7.99	Pass
1	1	2412	0.88	3.01	3.89	7.99	Pass
	6	2437	4.50	3.01	7.51	7.99	Pass
	11	2462	0.09	3.01	3.10	7.99	Pass

NOTE: Directional gain = $3\text{dBi} + 10\log(2) = 6.01\text{dBi} > 6\text{dBi}$, so the power density limit shall be reduced to $8-(6.01-6) = 7.99\text{dBm}$.

802.11g

TX chain	Channel	Freq. (MHz)	PSD (dBm)	10 log (N=2) dB	Total PSD (dBm)	Limit (dBm)	Pass /Fail
0	1	2412	-7.12	3.01	-4.11	7.99	Pass
	6	2437	-5.71	3.01	-2.70	7.99	Pass
	11	2462	-8.85	3.01	-5.84	7.99	Pass
1	1	2412	-7.19	3.01	-4.18	7.99	Pass
	6	2437	-5.76	3.01	-2.75	7.99	Pass
	11	2462	-8.38	3.01	-5.37	7.99	Pass

NOTE: Directional gain = $3\text{dBi} + 10\log(2) = 6.01\text{dBi} > 6\text{dBi}$, so the power density limit shall be reduced to $8-(6.01-6) = 7.99\text{dBm}$.

802.11n (HT20)

TX chain	Channel	Freq. (MHz)	PSD (dBm)	10 log (N=2) dB	Total PSD (dBm)	Limit (dBm)	Pass /Fail
0	1	2412	-6.86	3.01	-3.85	7.99	Pass
	6	2437	-5.34	3.01	-2.33	7.99	Pass
	11	2462	-8.60	3.01	-5.59	7.99	Pass
1	1	2412	-7.03	3.01	-4.02	7.99	Pass
	6	2437	-5.45	3.01	-2.44	7.99	Pass
	11	2462	-8.34	3.01	-5.33	7.99	Pass

NOTE: Directional gain = $3\text{dBi} + 10\log(2) = 6.01\text{dBi} > 6\text{dBi}$, so the power density limit shall be reduced to $8-(6.01-6) = 7.99\text{dBm}$.

802.11n (HT40)

TX chain	Channel	Freq. (MHz)	PSD (dBm)	10 log (N=2) dB	Total PSD (dBm)	Limit (dBm)	Pass /Fail
0	3	2422	-18.95	3.01	-15.94	7.99	Pass
	6	2437	-12.36	3.01	-9.35	7.99	Pass
	9	2452	-17.39	3.01	-14.38	7.99	Pass
1	3	2422	-18.31	3.01	-15.30	7.99	Pass
	6	2437	-12.49	3.01	-9.48	7.99	Pass
	9	2452	-19.05	3.01	-16.04	7.99	Pass

NOTE: Directional gain = 3dBi + 10log(2) = 6.01dBi > 6dBi , so the power density limit shall be reduced to 8-(6.01-6) = 7.99dBm.

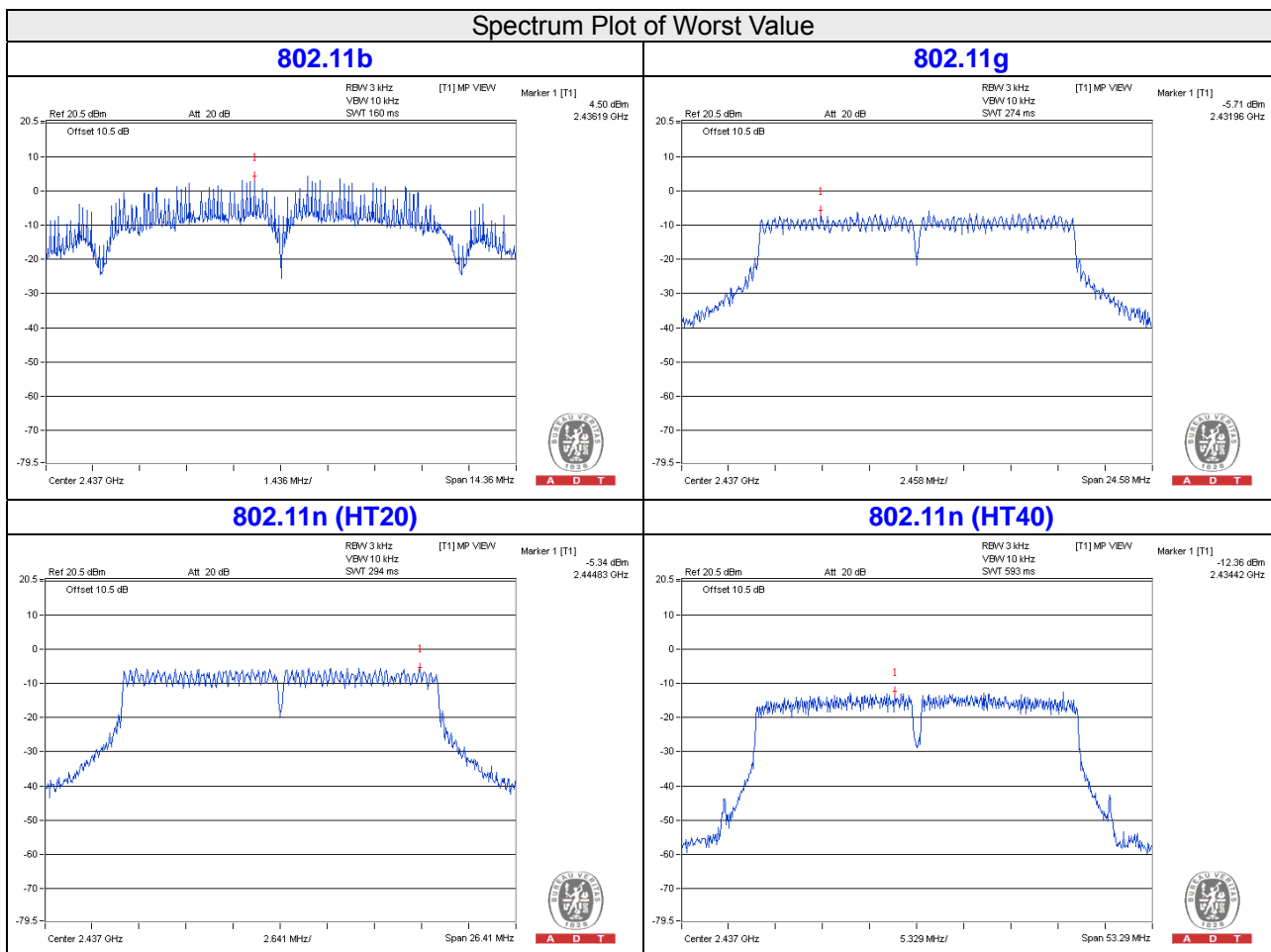

4.6 Conducted Out of Band Emission Measurement

4.6.1 Limits of Conducted Out of Band Emission Measurement

Below 20dB of the highest emission level of operating band (in 100kHz Resolution Bandwidth).

4.6.2 Test Setup

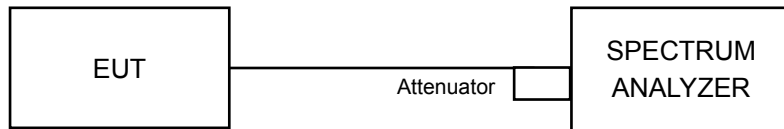

4.6.3 Test Instruments

Refer to section 4.1.2 to get information of above instrument.

4.6.4 Test Procedure

MEASUREMENT PROCEDURE REF

1. Set the RBW = 100 kHz.
2. Set the VBW \geq 300 kHz.
3. Detector = peak.
4. Sweep time = auto couple.
5. Trace mode = max hold.
6. Allow trace to fully stabilize.
7. Use the peak marker function to determine the maximum power level in any 100 kHz band segment within the fundamental EBW.

MEASUREMENT PROCEDURE OOBE

1. Set RBW = 100 kHz.
2. Set VBW \geq 300 kHz.
3. Detector = peak.
4. Sweep = auto couple.
5. Trace Mode = max hold.
6. Allow trace to fully stabilize.
7. Use the peak marker function to determine the maximum amplitude level.

4.6.5 Deviation from Test Standard

No deviation.

4.6.6 EUT Operating Condition

Same as Item 4.3.6

4.6.7 Test Results

The spectrum plots are attached on the following pages. D1 line indicates the highest level, and D2 line indicates the 20dB offset below D1. It shows compliance with the requirement.

802.11b
CHAIN 0

CH 1

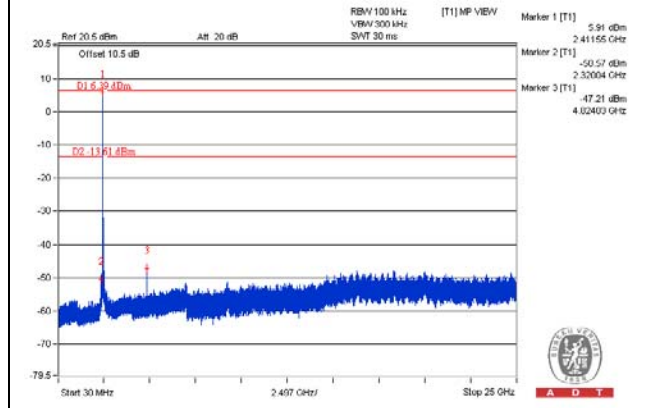
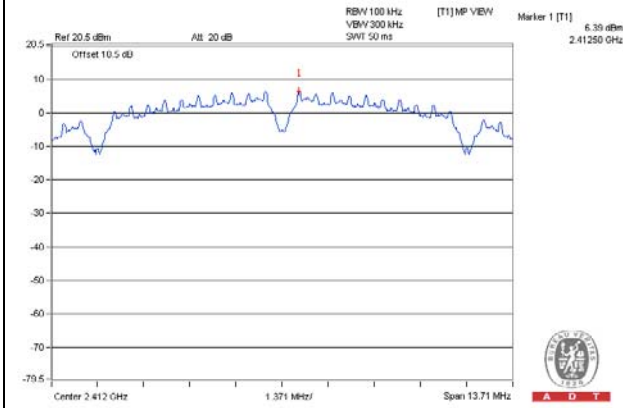

CH 6

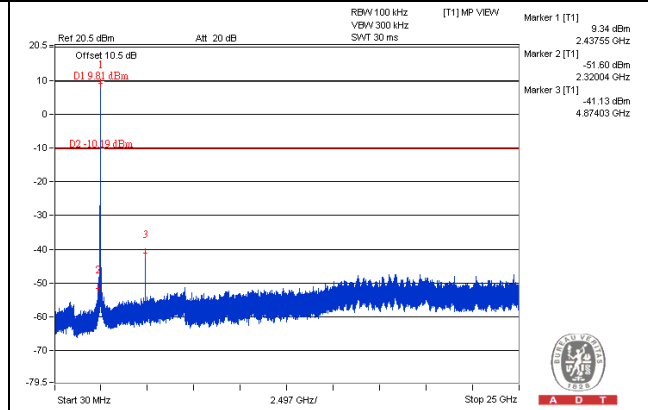
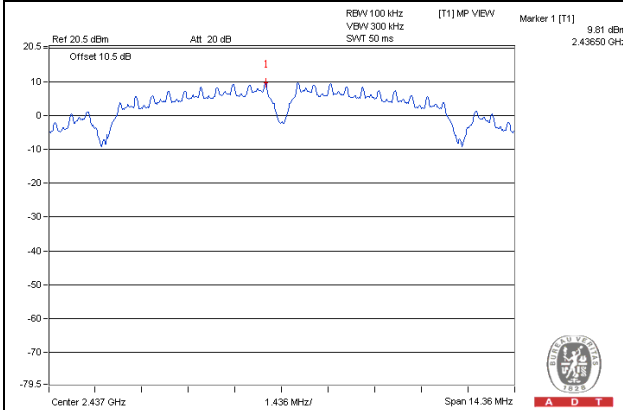

CH 11

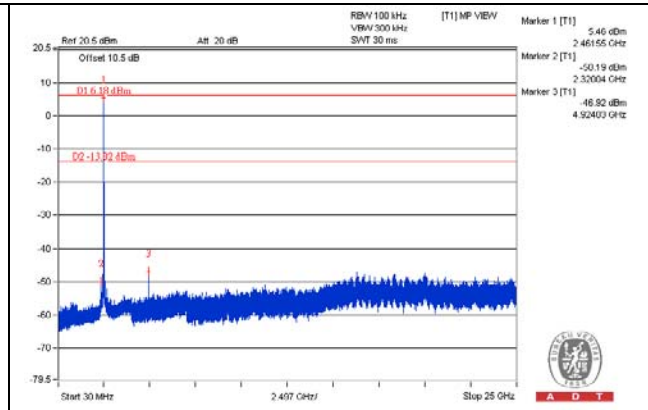
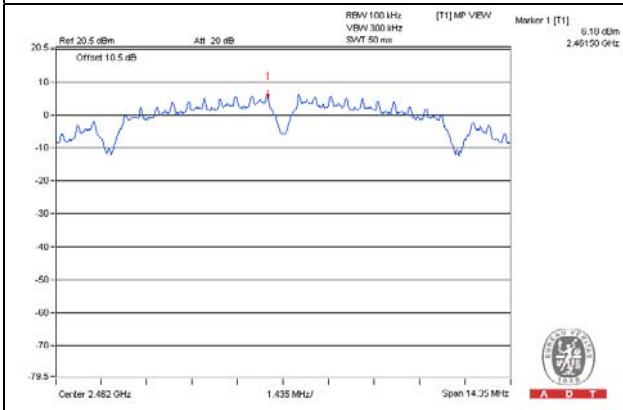

CH 1 Band edge

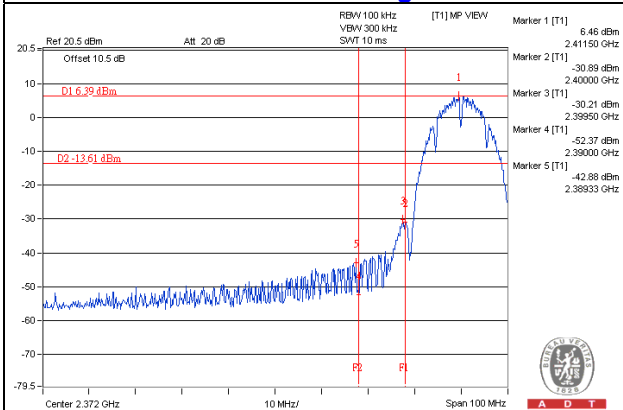

CH 11 Band edge

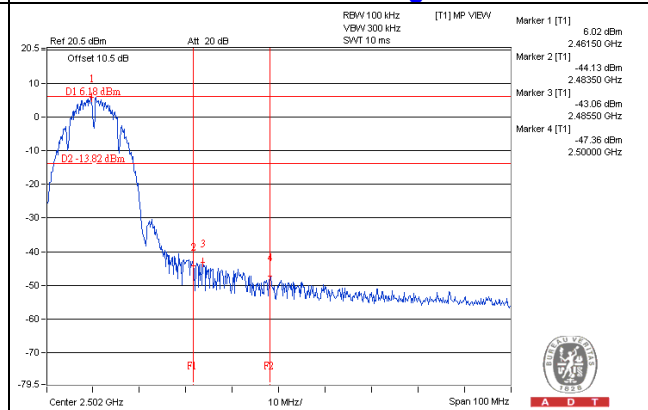

CHAIN 1

CH 1

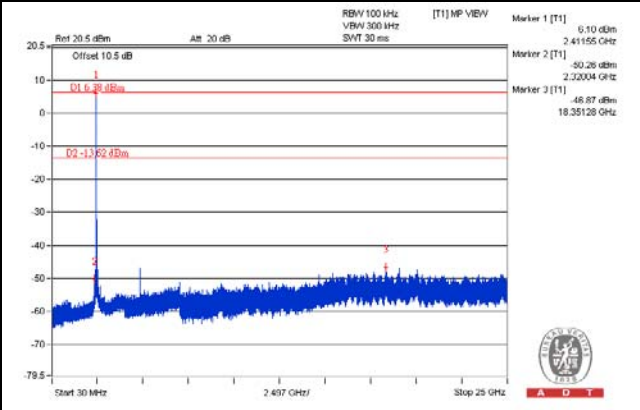
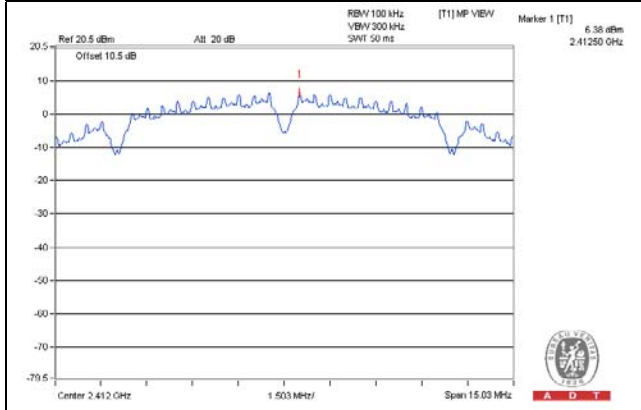

CH 6

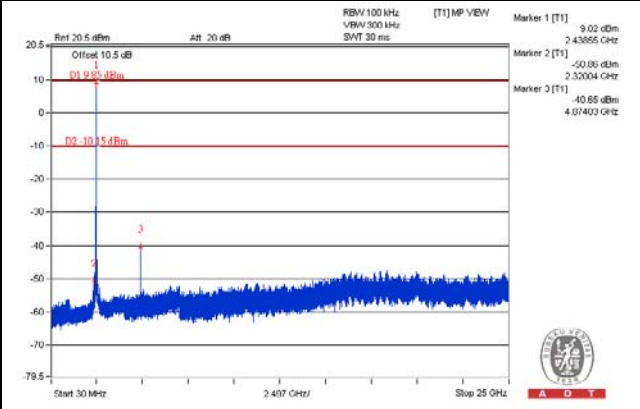
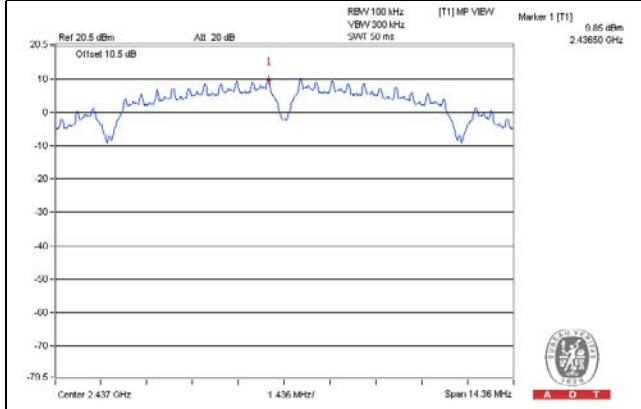

CH 11

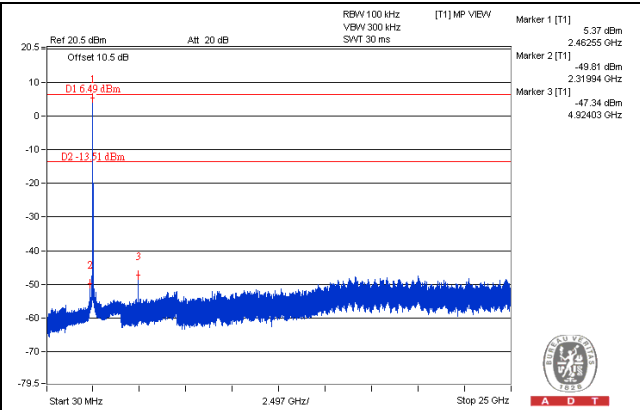
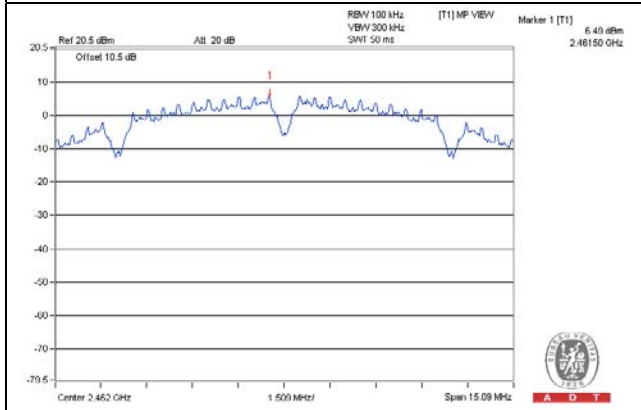

CH 1 Band edge

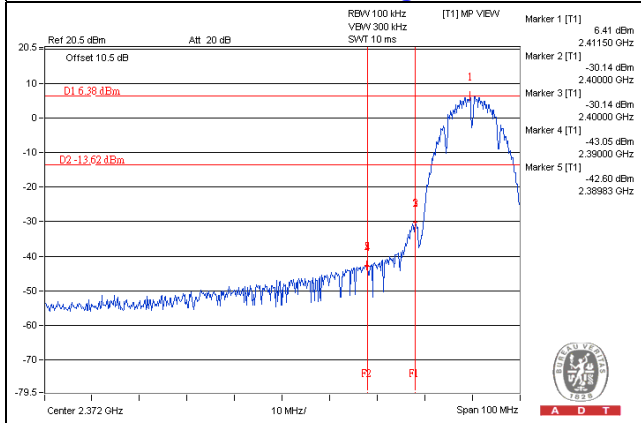

CH 11 Band edge

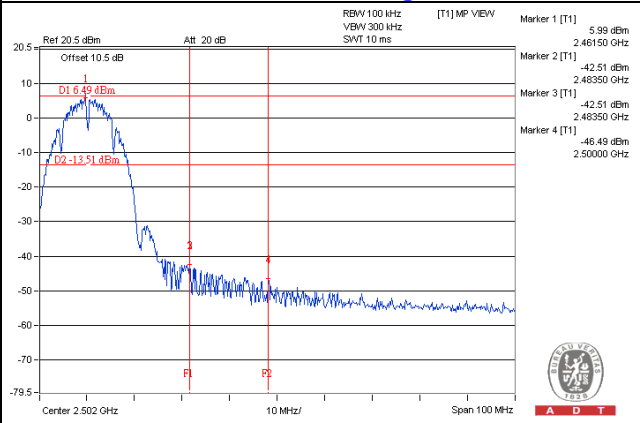

802.11g
CHAIN 0

CH 1

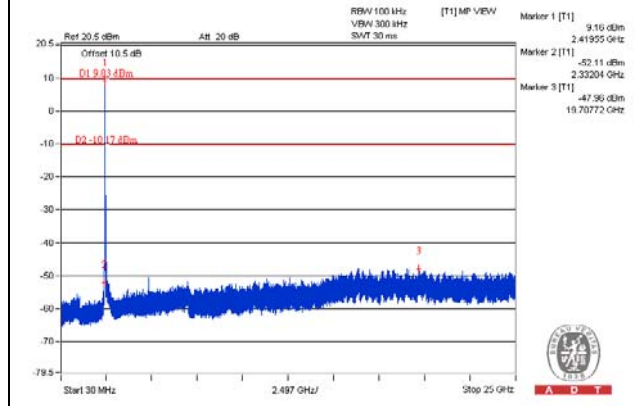
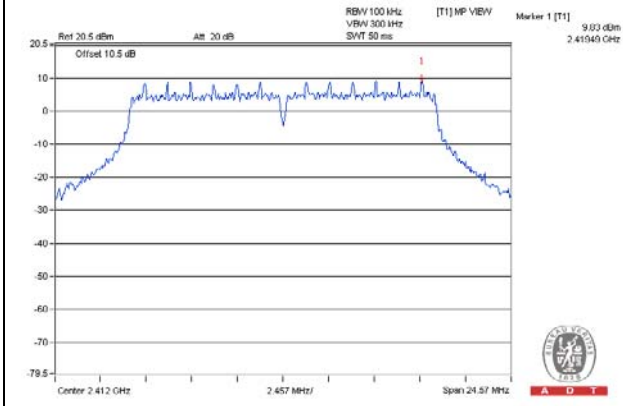

CH 6

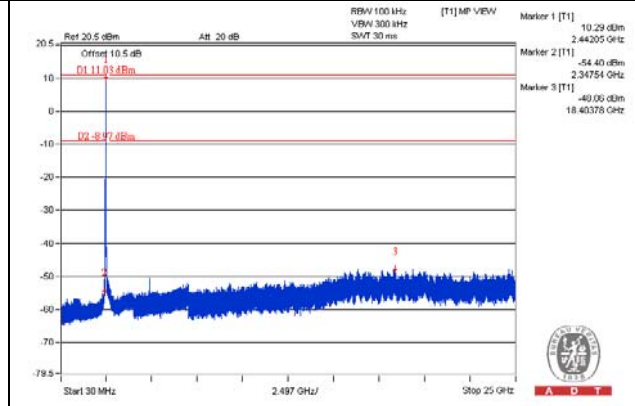
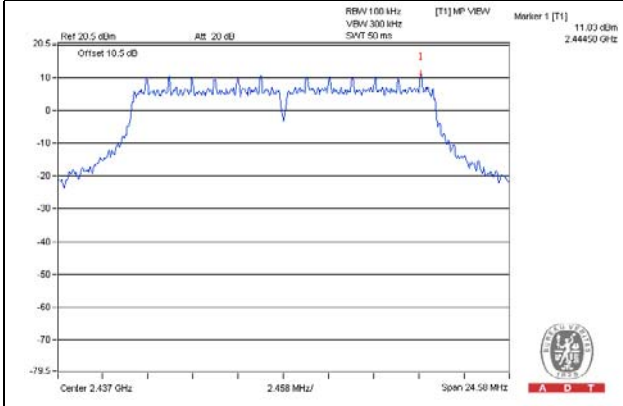

CH 11

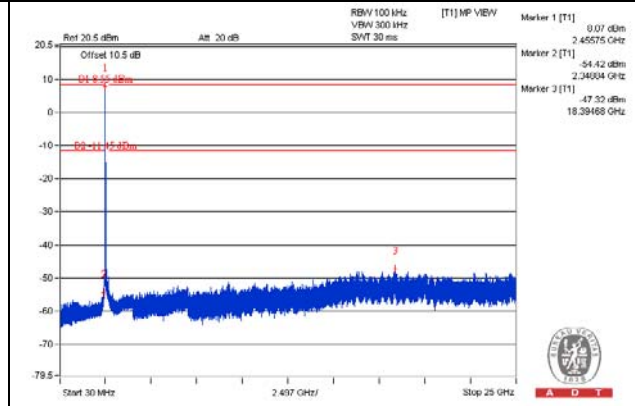
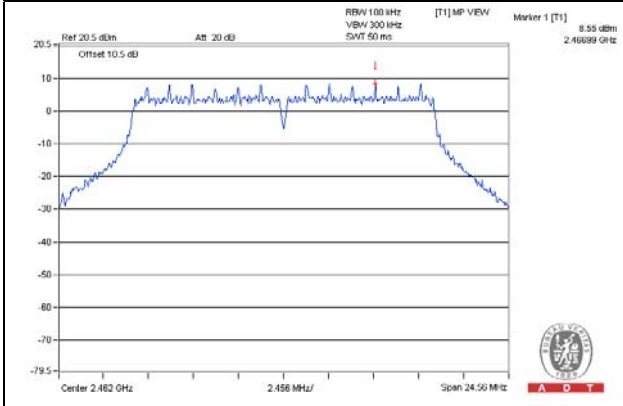

CH 1 Band edge

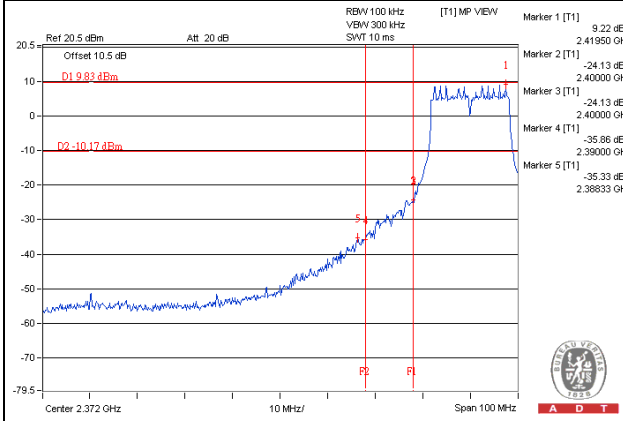

CH 11 Band edge

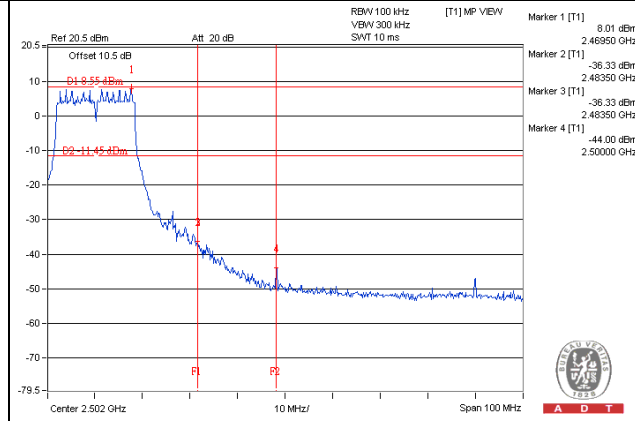

CHAIN 1

CH 1

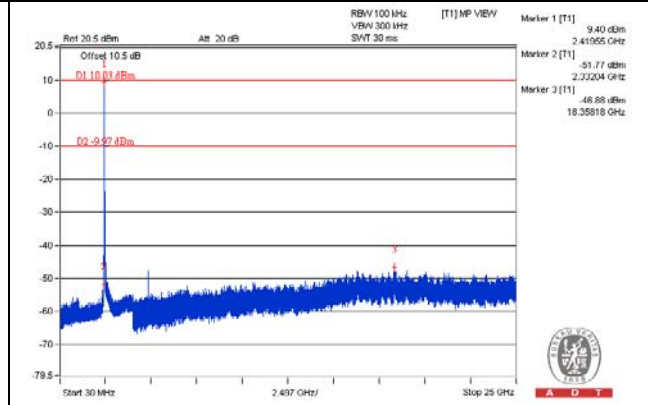
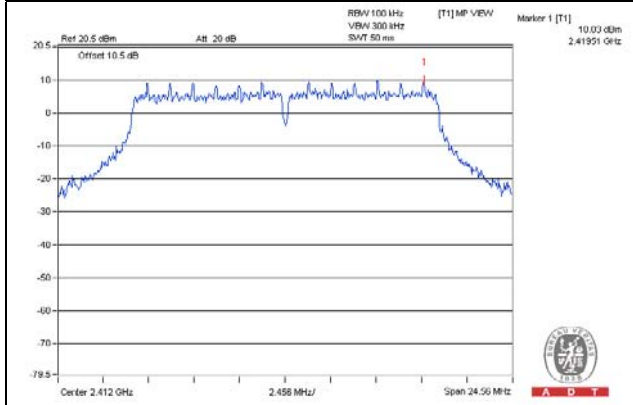

CH 6

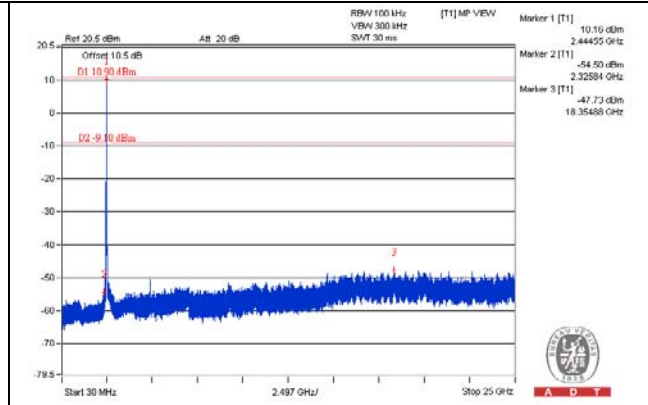
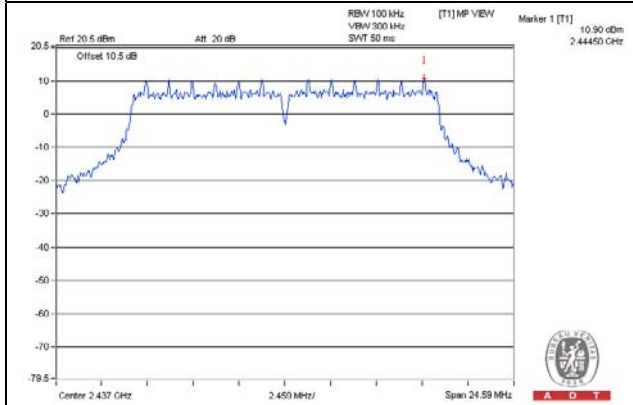

CH 11

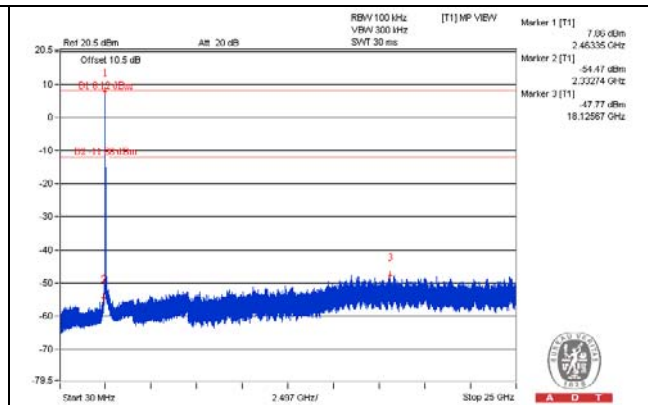
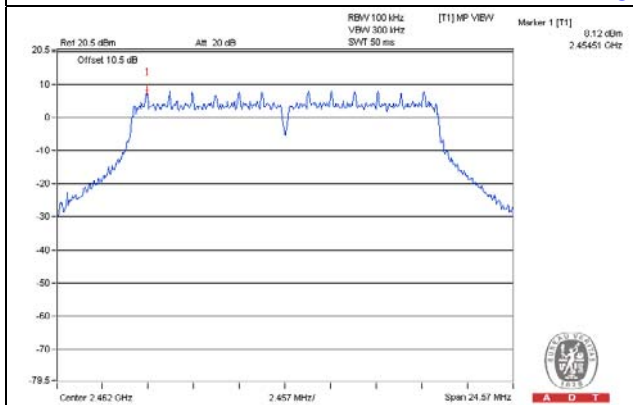

CH 1 Band edge

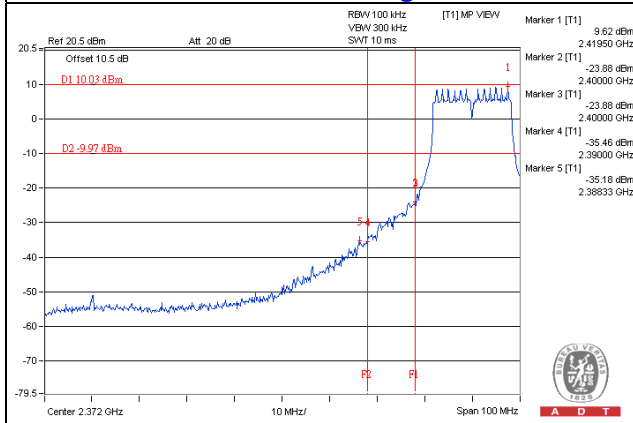

CH 11 Band edge

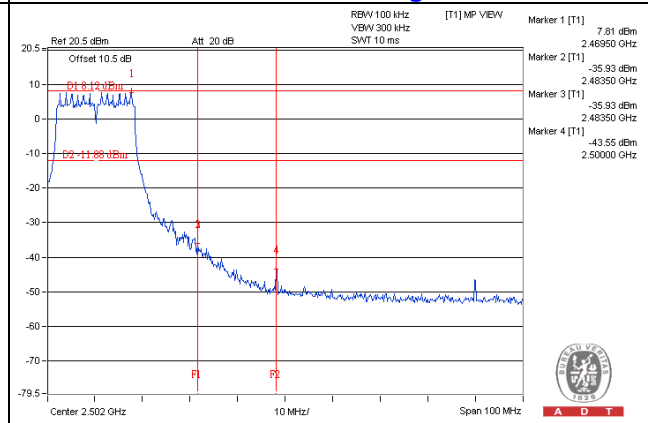

802.11n (HT20)
CHAIN 0

CH 1

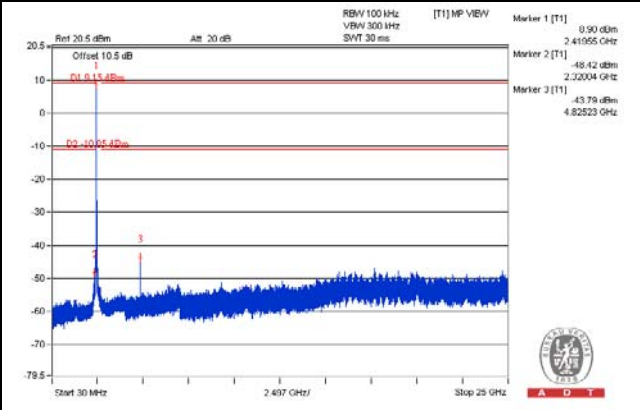
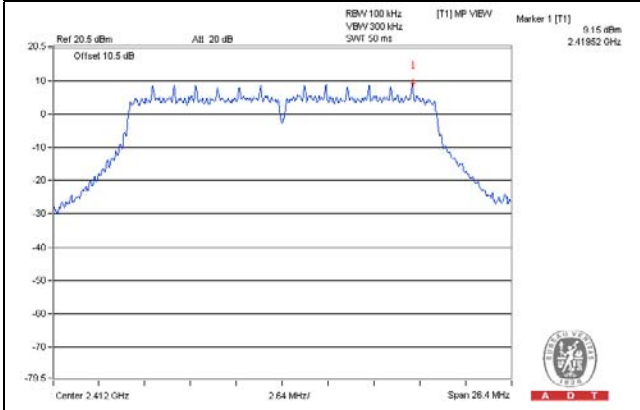

CH 6

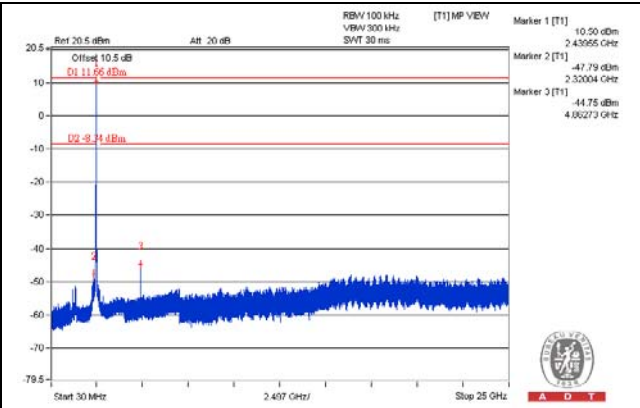
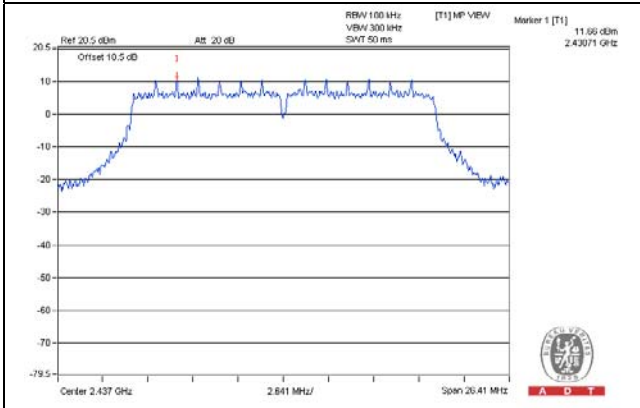

CH 11

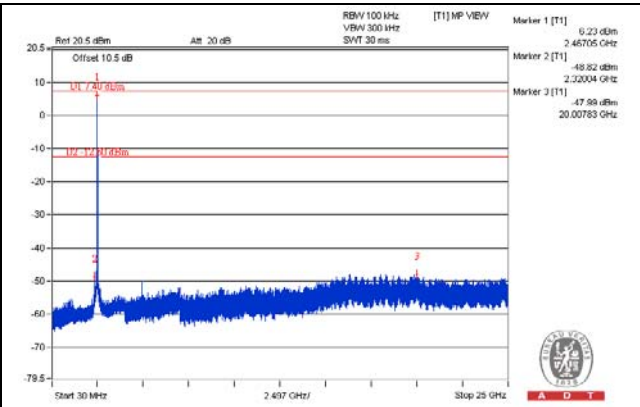
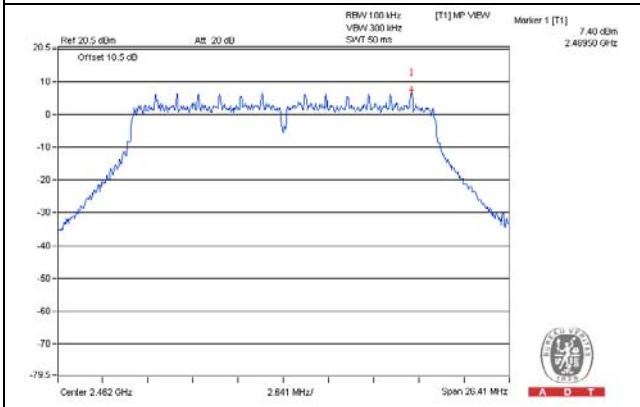

CH 1 Band edge

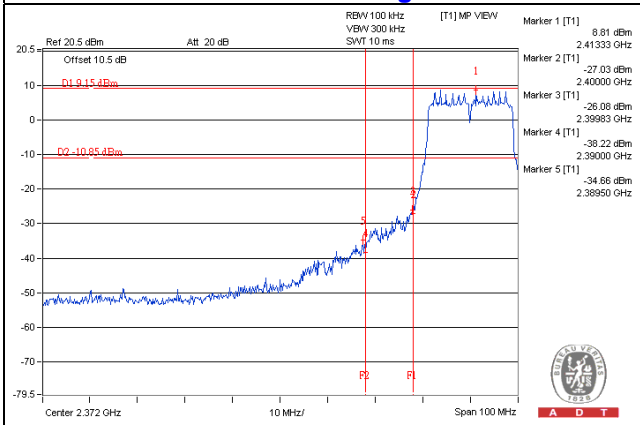

CH 11 Band edge

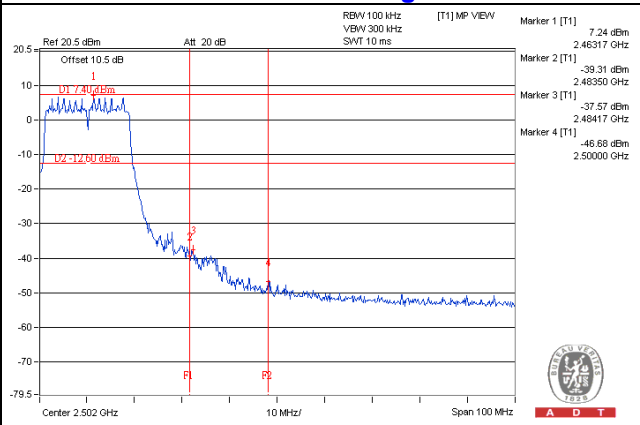

CHAIN 1

CH 1

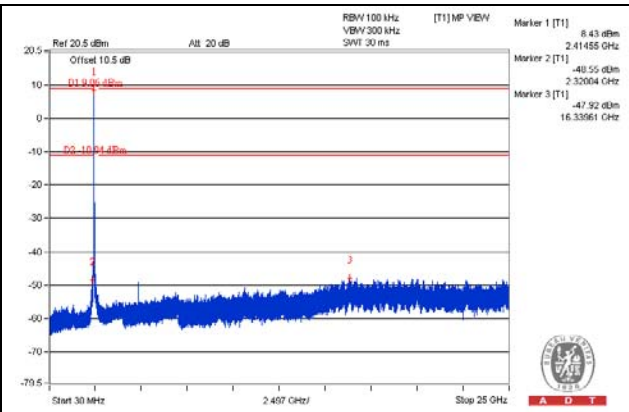
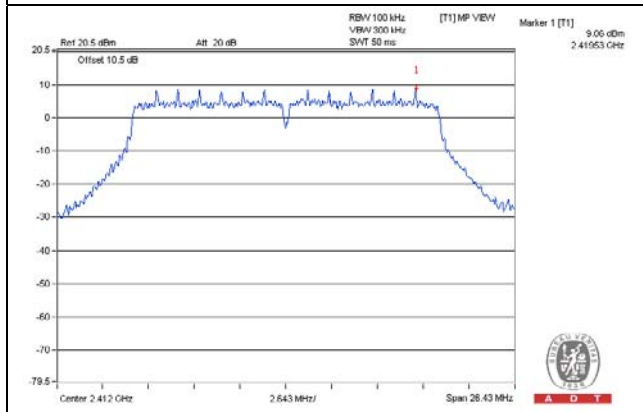

CH 6

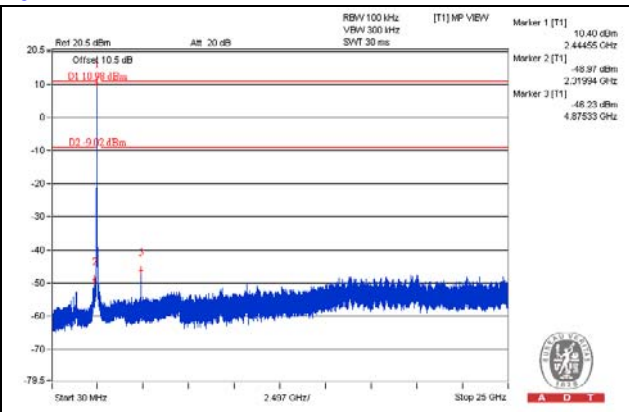
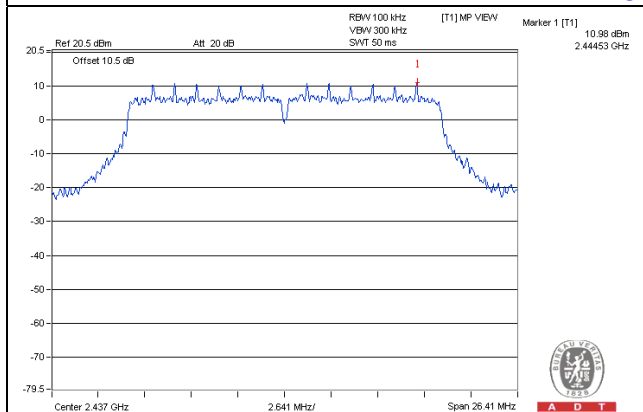

CH 11

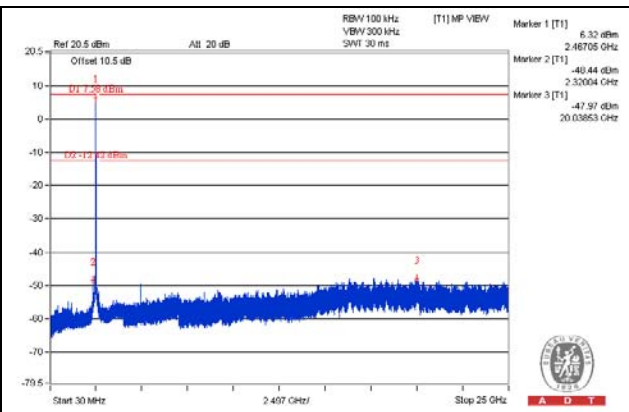
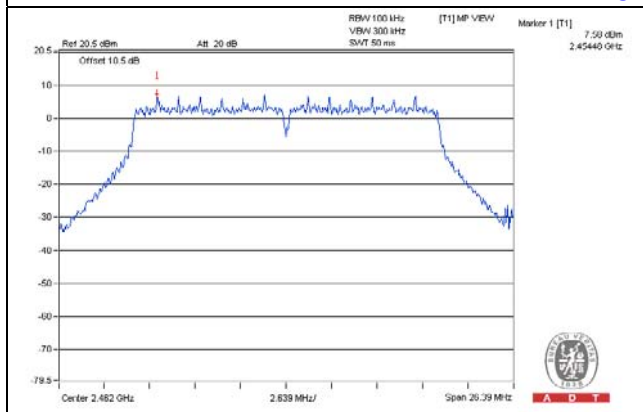

CH 1 Band edge

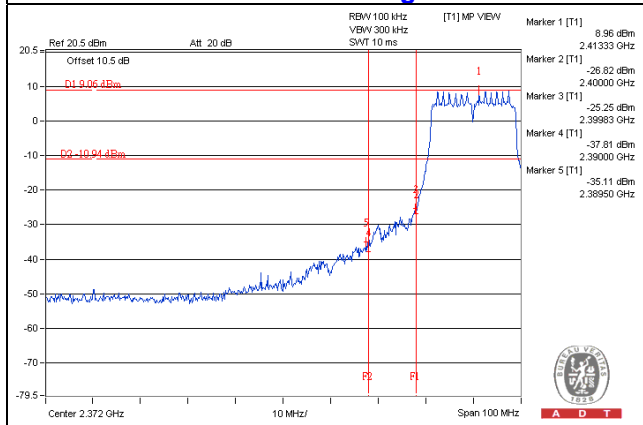

CH 11 Band edge

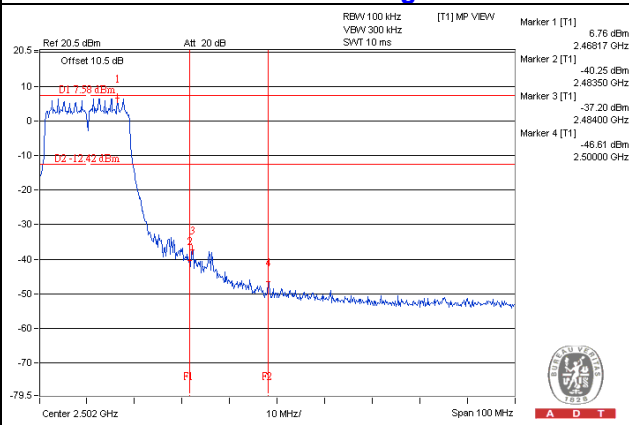

802.11n (HT40)
CHAIN 0

CH 3

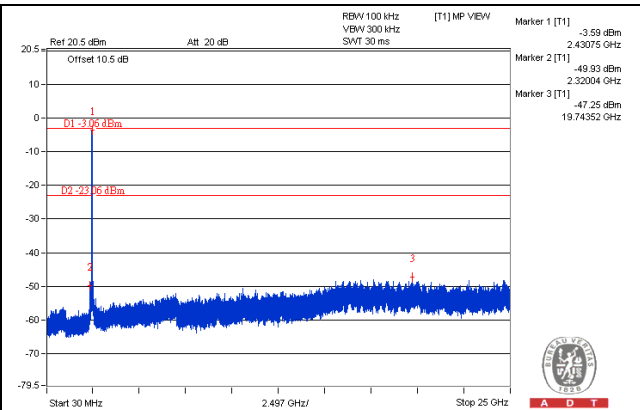
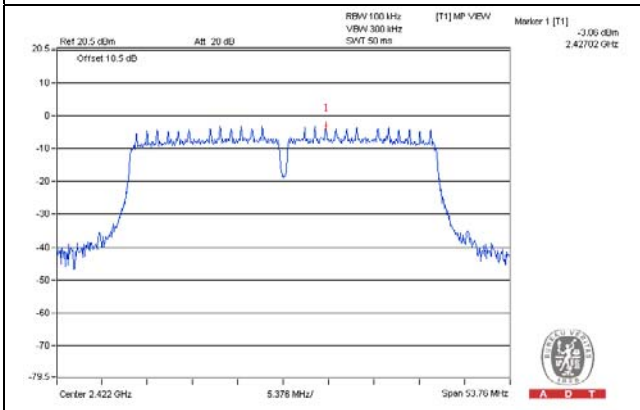

CH 6

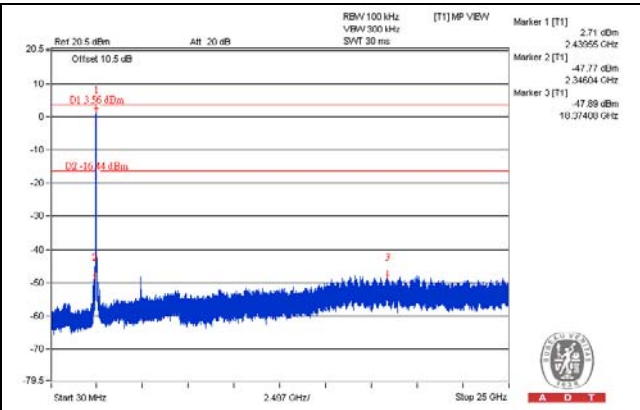
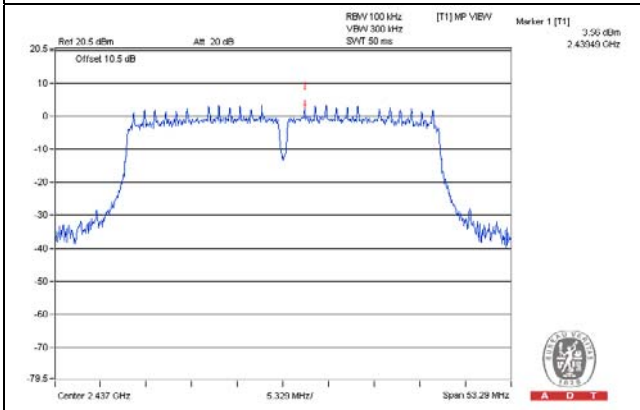

CH 9

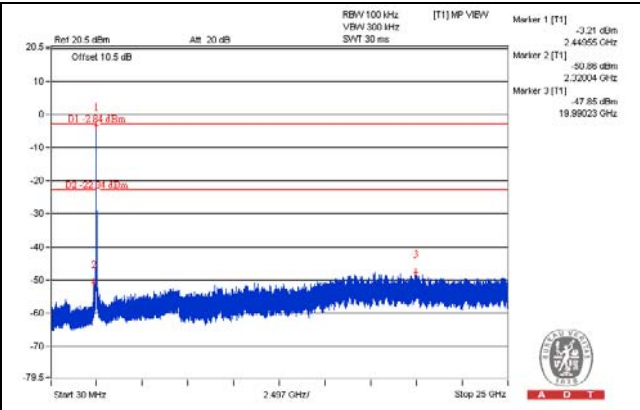
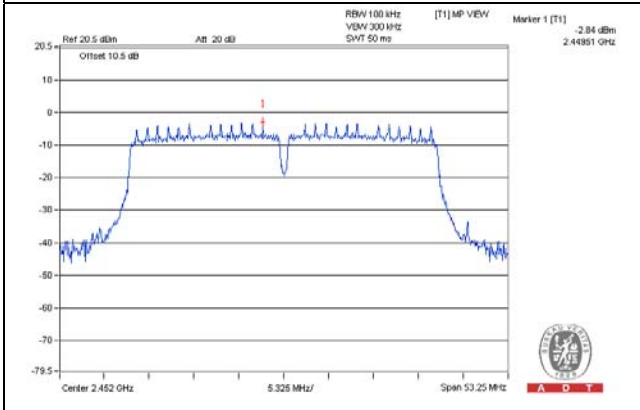

CH 3 Band edge

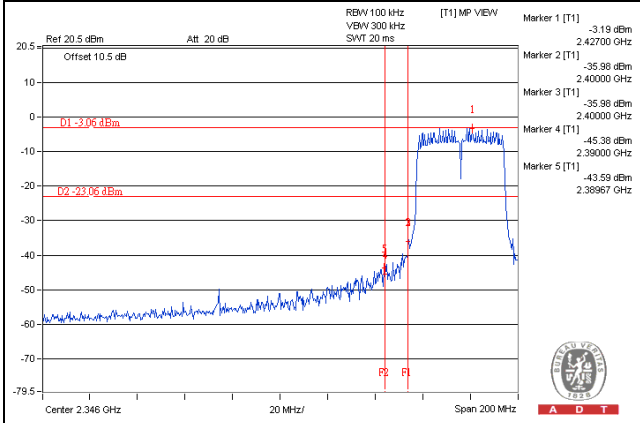

CH 9 Band edge

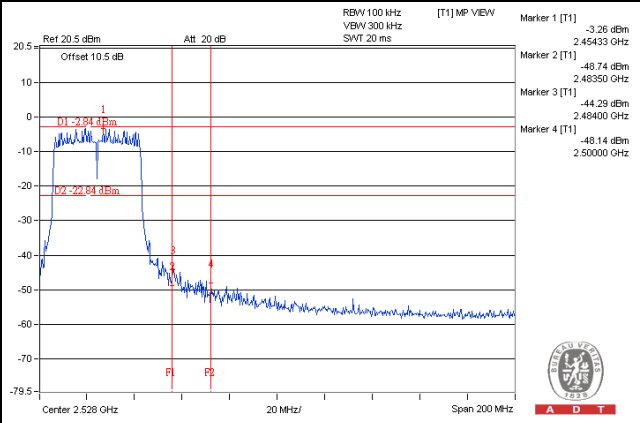

CHAIN 1

CH 3

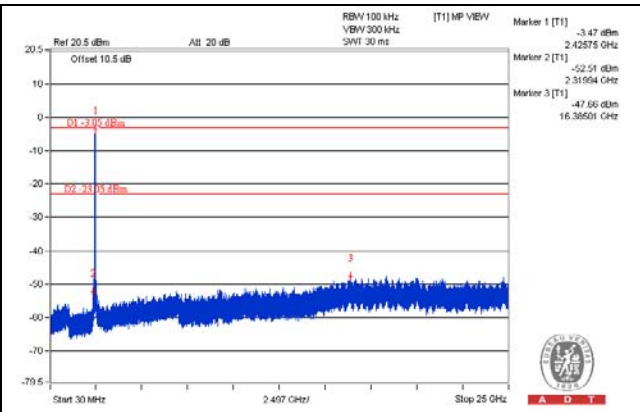
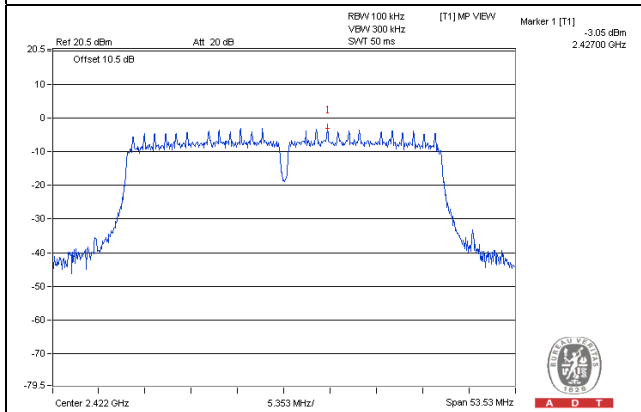

CH 6

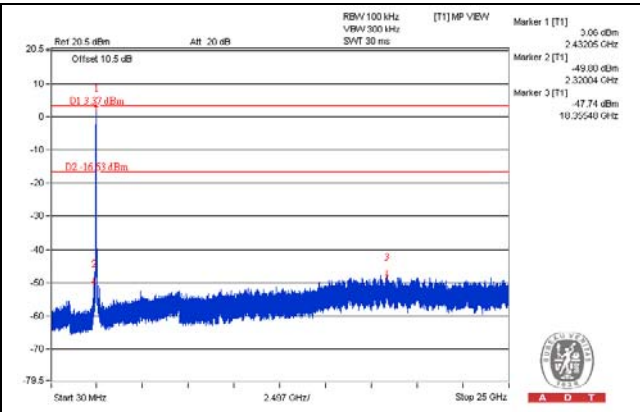
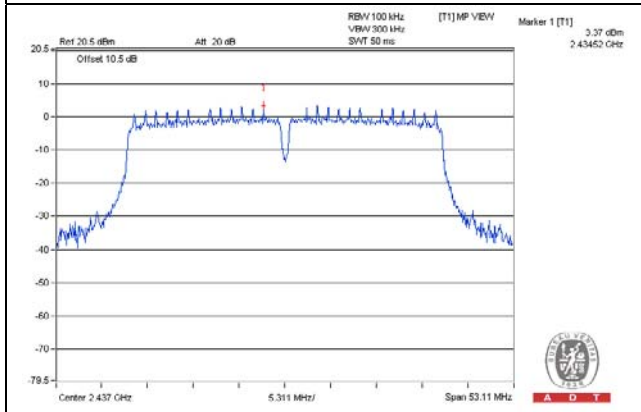

CH 9

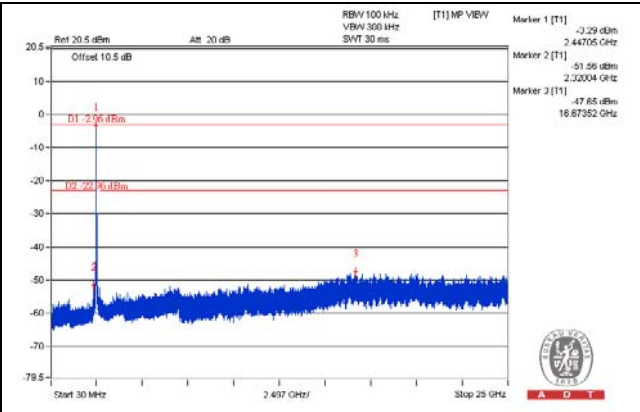
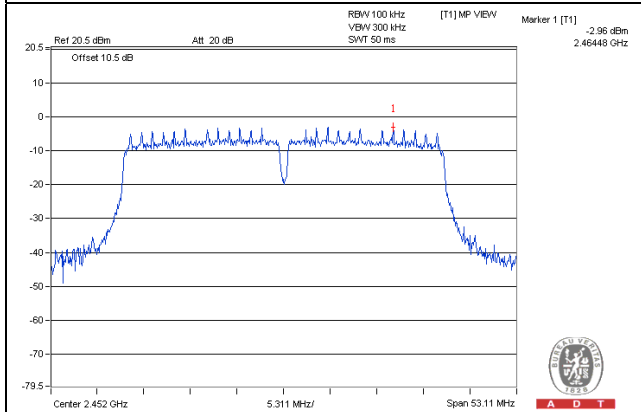

CH 3 Band edge

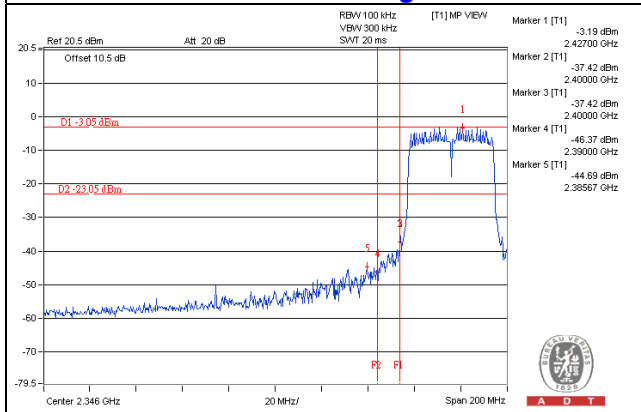

CH 9 Band edge

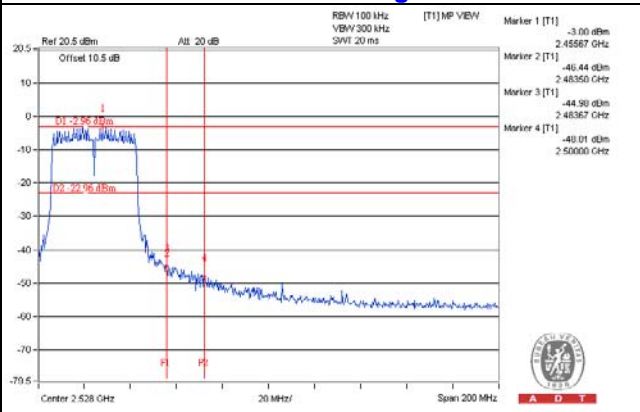

5 Pictures of Test Arrangements

Please refer to the attached file (Test Setup Photo).





Appendix – Information on the Testing Laboratories

We, Bureau Veritas Consumer Products Services (H.K.) Ltd., Taoyuan Branch, were founded in 1988 to provide our best service in EMC, Radio, Telecom and Safety consultation. Our laboratories are accredited and approved according to ISO/IEC 17025.

If you have any comments, please feel free to contact us at the following:

Linko EMC/RF Lab

Tel: 886-2-26052180

Fax: 886-2-26051924

Hsin Chu EMC/RF/Telecom Lab

Tel: 886-3-5935343

Fax: 886-3-5935342

Hwa Ya EMC/RF/Safety Lab

Tel: 886-3-3183232

Fax: 886-3-3270892

Email: service.adt@tw.bureauveritas.com

Web Site: www.bureauveritas-adt.com

The address and road map of all our labs can be found in our web site also.

--- END ---