



# FCC RADIO TEST REPORT

Applicant : D-Link Corporation

---

Address : 14420 Myford Road Suite 100 Irvine California  
United States 92606

---

Equipment : 1.BE3600 Wi-Fi 7 Smart Router  
2.Wi-Fi 7 BE3600 Mesh Router

---

Model No. : R36

---

Trade Name : D-Link

---

FCC ID : KA2R36B1

---

**I HEREBY CERTIFY THAT :**

The sample was received on Dec. 24, 2024 and the testing was completed on May. 23, 2025 at CerpPASS Technology Corp. The test result refers exclusively to the test presented test model / sample. Without written approval of CerpPASS Technology Corp., the test report shall not be reproduced except in full.

Approved by:

Mark Liao / Supervisor

Laboratory Accreditation:

CerpPASS Technology Corporation Test Laboratory





CONTENTS

- 1. Summary of Test Procedure and Test Results ..... 5
  - 1.1. Applicable Standards ..... 5
- 2. Test Configuration of Equipment under Test ..... 6
  - 2.1. Feature of Equipment under Test ..... 6
  - 2.2. Carrier Frequency of Channels ..... 7
  - 2.3. Test Mode and Test Software ..... 9
  - 2.4. Description of Test System ..... 11
  - 2.5. General Information of Test ..... 12
  - 2.6. Measurement Uncertainty ..... 13
- 3. Test Equipment and Ancillaries Used for Tests ..... 14
- 4. Antenna Requirements ..... 16
  - 4.1. Standard Applicable ..... 16
  - 4.2. Antenna Construction and Directional Gain ..... 17
- 5. Test of AC Power Line Conducted Emission ..... 18
  - 5.1. Test Limit ..... 18
  - 5.2. Test Procedures ..... 18
  - 5.3. Typical Test Setup ..... 19
  - 5.4. Test Result and Data ..... 20
  - 5.5. Test Photographs ..... 22
- 6. Test of Spurious Emission (Radiated) ..... 23
  - 6.1. Test Limit ..... 23
  - 6.2. Test Procedures ..... 24
  - 6.3. Typical Test Setup ..... 25
  - 6.4. Test Result and Data (9kHz ~ 30MHz) ..... 26
  - 6.5. Test Result and Data (30MHz ~ 1GHz) ..... 26
  - 6.6. Test Result and Data (1GHz ~ 40GHz) ..... 28
  - 6.7. Restricted Bands of Operation ..... 116
  - 6.8. Test Photographs (30MHz ~ 1GHz) ..... 117
  - 6.9. Test Photographs (1GHz ~ 40GHz) ..... 118
- 7. On Time, Duty Cycle and Measurement methods ..... 120
  - 7.1. Test Limit ..... 120
  - 7.2. Test Procedure ..... 120
  - 7.3. Test Setup Layout ..... 120
  - 7.4. Test Result and Data ..... 121
  - 7.5. Measurement Methods ..... 121
- 8. 6dB Bandwidth & 99% Occupied Bandwidth ..... 126
  - 8.1. Test Limit ..... 126
  - 8.2. Test Procedure ..... 126
  - 8.3. Test Setup Layout ..... 126
  - 8.4. Test Result and Data ..... 127
- 9. 26dB Bandwidth & 99% Occupied Bandwidth ..... 140
  - 9.1. Test Limit ..... 140



- 9.2. Test Procedure ..... 140
- 9.3. Test Setup Layout ..... 140
- 9.4. Test Result and Data ..... 141
- 10. Average Power ..... 181
  - 10.1. Test Limit ..... 181
  - 10.2. Test Procedure ..... 182
  - 10.3. Test Setup Layout ..... 182
  - 10.4. Test Result and Data ..... 183
- 11. Power Spectral Density ..... 215
  - 11.1. Test Limit ..... 215
  - 11.2. Test Procedure ..... 215
  - 11.3. Test Setup Layout ..... 215
  - 11.4. Test Result and Data ..... 216





# 1. Summary of Test Procedure and Test Results

## 1.1. Applicable Standards

**ANSI C63.10:2013**

**FCC Rules and Regulations Part 15 Subpart E §15.407**

**KDB 789033**

FCC Rule	Description of Test	Result
15.203	Antenna Requirement	PASS
15.207(a)	AC Power Line Conducted Emission	PASS
15.407(b) 15.209	Radiated Spurious Emission	PASS
15.407(a)	26 dB & Occupied Bandwidth	PASS
15.407	6 dB Bandwidth	PASS
15.407 (a) & (a)(3)	Average Power	PASS
15.407(a)	Power Spectral Density	PASS
2.1091	Radio Frequency Exposure	PASS

\*The lab has reduced the uncertainty risk factor from test equipment, environment and staff technicians which according to the standard on contract. Therefore, the test result will only be determined by standard requirement, measurement uncertainty evaluation is not considered.



## 2. Test Configuration of Equipment under Test

### 2.1. Feature of Equipment under Test

Operation Frequency Range	802.11b/g/n(Turbo QAM)/ax/be: 2400-2483.5MHz 802.11a/n/ac/ax/be: 5150-5250MHz, 5250-5350MHz, 5470-5725MHz, 5725-5875MHz
Center Frequency Range	802.11b/g/n(Turbo QAM)/ax/be: 2412MHz-2462MHz 802.11a/n/ac/ax/be: 5180-5240MHz, 5260-5320MHz, 5500-5720MHz, 5745-5825MHz
Modulation Type	2.4GHz: 802.11b: CCK, DQPSK, DBPSK 802.11g/n: BPSK, QPSK, 16QAM, 64QAM, 256QAM(TurboQAM) 802.11ax: BPSK, QPSK, 16QAM, 64QAM, 256QAM, 1024QAM 802.11be: BPSK, QPSK, 16QAM, 64QAM, 256QAM, 1024QAM, 4096QAM 5GHz: 802.11n/a: BPSK, QPSK, 16QAM, 64QAM 802.11ac: BPSK, QPSK, 16QAM, 64QAM, 256QAM 802.11ax: BPSK, QPSK, 16QAM, 64QAM, 256QAM, 1024QAM 802.11be: BPSK, QPSK, 16QAM, 64QAM, 256QAM, 1024QAM, 4096QAM
Modulation Technology	DSSS, OFDM, OFDMA
Data Rate	2.4GHz: 802.11b: 1, 2, 5.5, 11Mbps 802.11g: 6, 9, 12, 18, 24, 36, 48, 54Mbps 802.11n: MCS0 – MCS15,HT20/40 MCS0 – MCS9, VHT20/40(TurboQAM) 802.11ax: MCS0 – MCS11,HE20/40 802.11be: MCS0 – MCS13,EHT20/40 5GHz: 802.11a: 6, 9, 12, 18, 24, 36, 48, 54Mbps 802.11n: MCS0 – MCS15, HT20/40 802.11ac: MCS0 – MCS9, VHT20/40/80/160 802.11ax: MCS0 – MCS11,HE20/40/80/160 802.11be: MCS0 – MCS13,EHT20/40/80/160
Antenna Type	Dipole Antenna
Antenna Gain	2400-2500MHz: ANT B: 1.42dBi, ANT C: 1.74dBi 5150-5250MHz: ANT A 1.48dBi, ANT D: 0.74dBi 5250-5350MHz: ANT A 1.11dBi, ANT D: 1.28dBi 5470-5725MHz: ANT A 1.37dBi, ANT D: 1.47dBi 5725-5850MHz: ANT A 1.37dBi, ANT D: 1.88dBi
Adapter	1. Brand: AMIGO, Model: AMS200-1201500F 2. Brand: AMIGO, Model: AMS200-1201500FU
RJ45 Cable	1. Brand: Nienyi, Model: NYS6200

Note:

1. EUT support TPC Function.
2. EUT support AP Mode(Master)
3. EUT support Bridge/Extender/Mesh Mode(Master/Client)
4. EUT only support Full RU.
5. EUT FW: 1.00.12
6. WLAN 2.4GHz 802.11ax/be support beamforming Function.
7. WLAN 5GHz 802.11ax/be support beamforming Function.
8. For more details, please refer to the User's manual of the EUT.



## 2.2. Carrier Frequency of Channels

Band: 5150MHz-5250MHz

802.11a, 802.11n HT20, 802.11ac VHT20, 802.11ax HE20, 802.11be EHT20

Channel	Frequency(MHz)	Channel	Frequency(MHz)
<b>*36</b>	<b>5180</b>	44	5220
<b>*40</b>	<b>5200</b>	<b>*48</b>	<b>5240</b>

802.11n HT40, 802.11ac VHT40, 802.11ax HE40, 802.11be EHT40

Channel	Frequency(MHz)	Channel	Frequency(MHz)
<b>*38</b>	<b>5190</b>	<b>*46</b>	<b>5230</b>

802.11ac VHT80, 802.11ax HE80, 802.11be EHT80

Channel	Frequency(MHz)
<b>*42</b>	<b>5210</b>

Band: 5250MHz-5350MHz

802.11a, 802.11n HT20, 802.11ac VHT20, 802.11ax HE20, 802.11be EHT20

Channel	Frequency(MHz)	Channel	Frequency(MHz)
<b>*52</b>	<b>5260</b>	<b>*60</b>	<b>5300</b>
56	5280	<b>*64</b>	<b>5320</b>

802.11n HT40, 802.11ac VHT40, 802.11ax HE40, 802.11be EHT40

Channel	Frequency(MHz)	Channel	Frequency(MHz)
<b>*54</b>	<b>5270</b>	<b>*62</b>	<b>5310</b>

802.11ac VHT80, 802.11ax HE80, 802.11be EHT80

Channel	Frequency(MHz)
<b>*58</b>	<b>5290</b>

Band: 5150MHz -5350MHz: Straddle Channel

802.11ac VHT160, 802.11ax HE160

Channel	Frequency(MHz)
<b>*50</b>	<b>5250</b>

Band: 5470MHz-5725MHz

802.11a, 802.11n HT20, 802.11ac VHT20, 802.11ax HE20, 802.11be EHT20

Channel	Frequency(MHz)	Channel	Frequency(MHz)
<b>*100</b>	<b>5500</b>	124	5620
104	5520	128	5640
108	5540	132	5660
112	5560	136	5680
116	5580	<b>*140</b>	<b>5700</b>
<b>*120</b>	<b>5600</b>		

802.11n HT40, 802.11ac VHT40, 802.11ax HE40, 802.11be EHT40

Channel	Frequency(MHz)	Channel	Frequency(MHz)
<b>*102</b>	<b>5510</b>	126	5630
110	5550	<b>*134</b>	<b>5670</b>
<b>*118</b>	<b>5590</b>		

802.11ac VHT80, 802.11ax HE80, 802.11be EHT80

Channel	Frequency(MHz)	Channel	Frequency(MHz)
<b>*106</b>	<b>5530</b>	<b>*122</b>	<b>5610</b>

802.11ac VHT160, 802.11ax HE160

Channel	Frequency(MHz)
<b>*114</b>	<b>5570</b>



Band 3: Straddle Channel

802.11a, 802.11n HT20, 802.11ac VHT20, 802.11ax HE20, 802.11be EHT20

Channel	Frequency(MHz)
<b>*144</b>	<b>5720</b>

802.11n HT40, 802.11ac VHT40, 802.11ax HE40, 802.11be EHT40

Channel	Frequency(MHz)
<b>*142</b>	<b>5710</b>

802.11ac VHT80, 802.11ax HE80, 802.11be EHT80

Channel	Frequency(MHz)
<b>*138</b>	<b>5690</b>

Band: 5725MHz-5850MHz

802.11a, 802.11n HT20, 802.11ac VHT20, 802.11ax HE20, 802.11be EHT20

Channel	Frequency(MHz)	Channel	Frequency(MHz)
<b>*149</b>	<b>5745</b>	161	5805
153	5765	<b>*165</b>	<b>5825</b>
<b>*157</b>	<b>5785</b>		

802.11n HT40, 802.11ac VHT40, 802.11ax HE40, 802.11be EHT40

Channel	Frequency(MHz)	Channel	Frequency(MHz)
<b>*151</b>	<b>5755</b>	<b>*159</b>	<b>5795</b>

802.11ac VHT80, 802.11ax HE80, 802.11be EHT80

Channel	Frequency(MHz)
<b>*155</b>	<b>5775</b>

Note: Channels remarked \* are selected to perform test.



### 2.3. Test Mode and Test Software

- a. During testing, the interface cables and equipment positions were varied according to ANSI C63.10.
- b. The complete test system included remote workstation and EUT for RF test. The remote workstation included Notebook.
- c. An executive program, "QSPR ver.6.00.00164.3" under Windows OS system was executed to transmit and receive data via WLAN.
- d. The following test modes were performed for the test:

Conducted Emissions from the AC mains power ports	
Test Mode	Operating Description
1	802.11a (6Mbps), TX Mode
2	802.11n HT20 (6.5Mbps), TX Mode
3	802.11n HT40 (13.5Mbps), TX Mode
4	802.11ac VHT20 (6.5Mbps), TX Mode
5	802.11ac VHT40 (13.5Mbps), TX Mode
6	802.11ac VHT80 (29.3Mbps), TX Mode
7	802.11ac VHT160 (58.5Mbps), TX Mode
8	802.11ax HE20 (7.3Mbps), TX Mode
9	802.11ax HE40 (14.6Mbps), TX Mode
10	802.11ax HE80 (30.6Mbps), TX Mode
11	802.11ax HE160 (61.3Mbps), TX Mode
12	802.11be EHT20 (7.3Mbps), TX Mode
13	802.11be EHT40 (14.6Mbps), TX Mode
14	802.11be EHT80 (30.6Mbps), TX Mode
15	802.11be EHT160 (61.3Mbps), TX Mode
caused "Test Mode 12" generated the worst case, it was reported as the final data.	
Radiation Emissions (Below 1GHz)	
Test Mode	Operating Description
1	802.11a (6Mbps), TX Mode
2	802.11n HT20 (6.5Mbps), TX Mode
3	802.11n HT40 (13.5Mbps), TX Mode
4	802.11ac VHT20 (6.5Mbps), TX Mode
5	802.11ac VHT40 (13.5Mbps), TX Mode
6	802.11ac VHT80 (29.3Mbps), TX Mode
7	802.11ac VHT160 (58.5Mbps), TX Mode
8	802.11ax HE20 (7.3Mbps), TX Mode
9	802.11ax HE40 (14.6Mbps), TX Mode
10	802.11ax HE80 (30.6Mbps), TX Mode
11	802.11ax HE160 (61.3Mbps), TX Mode
12	802.11be EHT20 (7.3Mbps), TX Mode
13	802.11be EHT40 (14.6Mbps), TX Mode
14	802.11be EHT80 (30.6Mbps), TX Mode
15	802.11be EHT160 (61.3Mbps), TX Mode
caused "Test Mode 12" generated the worst case, it was reported as the final data.	



Radiation Emissions (1GHz ~ 40GHz)	
Test Mode	Operating Description
1	802.11a (6Mbps), TX Mode
2	802.11n HT20 (6.5Mbps), TX Mode
3	802.11n HT40 (13.5Mbps), TX Mode
4	802.11ac VHT20 (6.5Mbps), TX Mode
5	802.11ac VHT40 (13.5Mbps), TX Mode
6	802.11ac VHT80 (29.3Mbps), TX Mode
7	802.11ac VHT160 (58.5Mbps), TX Mode
8	802.11ax HE20 (7.3Mbps), TX Mode
9	802.11ax HE40 (14.6Mbps), TX Mode
10	802.11ax HE80 (30.6Mbps), TX Mode
11	802.11ax HE160 (61.3Mbps), TX Mode
12	802.11be EHT20 (7.3Mbps), TX Mode
13	802.11be EHT40 (14.6Mbps), TX Mode
14	802.11be EHT80 (30.6Mbps), TX Mode
15	802.11be EHT160 (61.3Mbps), TX Mode

caused "Test Mode 1, 12~15" generated the worst case, it was reported as the final data.

Note:

- There are two kinds of test voltage: AC 120V / 60Hz and AC 240V / 60Hz.  
For AC Power Line Conducted Emission, AC 120V / 60Hz is worst case.  
For Radiated Spurious Emission, AC 120V / 60Hz is worst case.
- The EUT has two accessories of adapters:  
(1).Brand: AMIGO, Model: AMS200-1201500F  
(2).Brand: AMIGO, Model: AMS200-1201500FU  
For AC Power Line Conducted Emission, AMS200-1201500F is worst case.  
For Radiated Spurious Emission, AMS200-1201500FU is worst case.
- Non-Beamforming was the worst case, so it was used for the test result.

The EUT incorporates a MIMO function

Modulation Type	TX CONFIGURATION
802.11a	2TX
802.11n HT20	2TX
802.11n HT40	2TX
802.11ac VHT20	2TX
802.11ac VHT40	2TX
802.11ac VHT80	2TX
802.11ac VHT160	2TX
802.11ax HE20	2TX
802.11ax HE40	2TX
802.11ax HE80	2TX
802.11ax HE160	2TX
802.11be EHT20	2TX
802.11be EHT40	2TX
802.11be EHT80	2TX
802.11be EHT160	2TX



### 2.4. Description of Test System

Non-Beamforming:

RF Conducted				
Equipment	Brand	Model	Length/Type	Power cord/Length/Type
Notebook	DELL	Latitude 7490	N/A	Adapter / 1.8m / NS
RJ45 Cable	TE CONNECTIVITY	CAT5E	1.2m / NS	N/A
Radiated Emissions				
Equipment	Brand	Model	Length/Type	Power cord/Length/Type
Notebook	DELL	Latitude 7490	N/A	Adapter / 1.8m / NS
AC Power Line Conducted Emission				
Equipment	Brand	Model	Length/Type	Power cord/Length/Type
Notebook	DELL	Latitude 7490	N/A	Adapter / 1.8m / NS

Beamforming:

RF Conducted				
Equipment	Brand	Model	Length/Type	Power cord/Length/Type
Notebook	DELL	Latitude 7490	N/A	Adapter / 1.8m / NS
RJ45 Cable	TE CONNECTIVITY	CAT5E	1.2m / NS	N/A



**2.5. General Information of Test**

Organization	Cerpass Technology Corp.		
☒ Test Site	Cerpass Technology Corporation Test Laboratory Address: No.10, Ln. 2, Lianfu St., Luzhu Dist., Taoyuan City 33848, Taiwan (R.O.C.) Tel: +886-3-3226-888 Fax: +886-3-3226-881		
	FCC	TW1439, TW1079	
	IC	4934E-1, 4934E-2	
Frequency Range Investigated	Conducted: from 150kHz to 30 MHz Radiation: from 30 MHz to 40,000MHz		
Test Distance	The test distance of radiated emission from antenna to EUT is 3 M.		

**Non-Beamforming:**

Test Item	Test Site	Test period	Environmental Conditions	Tested By
RF Conducted	RFCON01-NK	2025/01/02	21.2°C / 51%	Leon Huang
RF Conducted	RFCON01-NK	2025/01/03	20.9°C / 54%	Leon Huang
RF Conducted	RFCON01-NK	2025/01/06	23.9°C / 47%	Leon Huang
RF Conducted	RFCON01-NK	2025/01/07	24.9°C / 49%	Leon Huang
RF Conducted	RFCON01-NK	2025/01/09	22.4°C / 46%	Leon Huang
Radiated Emissions	3M02-NK	2025/03/05	22.5°C / 43%	Park Chen
Radiated Emissions	3M02-NK	2025/03/20	20.3°C / 56%	Park Chen
AC Power Line Conducted Emission	CON02-NK	2025/03/20	17.1°C / 55%	Park Chen

**Beamforming:**

Test Item	Test Site	Test period	Environmental Conditions	Tested By
RF Conducted	RFCON01-NK	2025/01/11	22.4°C / 47%	Leon Huang
RF Conducted	RFCON01-NK	2025/01/13	22.6°C / 46%	Leon Huang
RF Conducted	RFCON01-NK	2025/05/05	24.7°C / 51%	Leon Huang
RF Conducted	RFCON01-NK	2025/05/23	25.8°C / 48%	Leon Huang



## 2.6. Measurement Uncertainty

ISO/IEC 17025 requires that an estimate of the measurement uncertainties associated with the emissions test results be included in the report. The measurement uncertainties given below are based on a 95% confidence level (based on a coverage factor (k=2))

Measurement Item	Uncertainty
AC Power Line Conduction(150K~30MHz)	±3.2dB
Radiated Spurious Emission(9KHz~30MHz)	±3.5dB
Radiated Spurious Emission(30MHz~1GHz)	±5.1dB
Radiated Spurious Emission(1GHz~40GHz)	±5.2dB
6dB Bandwidth	±5.4%
26dB Bandwidth	±4.4%
Occupied Bandwidth	±4.5%
Peak Output Power(Conducted Power Meter)	±1.1dB
Power Spectral Density	±2.0dB
Duty Cycle	±3.5%
Frequency Stability	±0.23KHz



### 3. Test Equipment and Ancillaries Used for Tests

Non-Beamforming:

Test Item	Radiated Emissions				
Test Site	Semi Anechoic Room(3M02-NK)				
Instrument	Manufacturer	Model No	Serial No	Calibration Date	Valid Date
Bilog Antenna	Schwarzbeck	VULB9168	369	2025/02/17	2026/02/16
Active Loop Antenna	EMCO	6507	00040855	2024/05/02	2025/05/01
Horn Antenna	EMCO	3115	31589	2025/02/14	2026/02/13
Horn Antenna	EMCO	3116	31970	2025/02/20	2026/02/19
EMI Receiver	ROHDE & SCHWARZ	ESR 7	101906	2024/05/13	2025/05/12
Spectrum Analyzer	ROHDE & SCHWARZ	FSV 40-N	101329	2024/07/16	2025/07/15
Preamplifier	Agilent	8449B	3008A01954	2025/02/12	2026/02/11
Preamplifier	EMC INSTRUMENTS	EMC184045	980065	2024/10/15	2025/10/14
Preamplifier	EM Electronics corp.	EM330	60659	2024/12/16	2025/12/15
Cable-4m(9k-3G)	EMEC	RG-223	18274M	2024/08/08	2025/08/07
Cable-3in1(30M-1G)	HARBOUR INDUSTRIES	LL142	CCE1315	2025/02/21	2026/02/20
Cable-0.5m(1G-40G)	HUBER SUHNER	SUCOFLEX 104	805443/4	2025/02/26	2026/02/25
Cable-3m(1G-40G)	HUBER SUHNER	SUCOFLEX 104	805796/4	2025/02/26	2026/02/25
Cable-8m(1G-26.5G)	WOKEN	WCBA-WCA203SM	CCE1374	2025/02/26	2026/02/25
Cable-3m(10M-40G)	HUBER SUHNER	SF102	804619/2	2024/10/14	2025/10/13
Cable-1m(10M-40G)	HUBER SUHNER	SF102	804398/2	2024/10/14	2025/10/13
E3	AUDIX	v8.2014-8-6	RK-000529	NA	NA
High Pass Filter	WOKEN	WFIL-H3000-18000F-03	WR377WC2B1	2024/10/15	2025/10/14
Notch Filter	Warison	WFIL-N5925-7125F-04	WRQ4BFWC4M1	2025/02/21	2026/02/20
Hipass Filter	Warison	WFIL-H7500-18000F	WRQ4BFWC2J1	2025/02/21	2026/02/20

Test Item	RF Conducted				
Test Site	RFCON01-NK				
Instrument	Manufacturer	Model No	Serial No	Calibration Date	Valid Date
Spectrum Analyzer	ROHDE & SCHWARZ	FSP 40	100047	2024/03/01	2025/02/28
Attenuator	KEYSIGHT	8491B	MY39250703	2024/02/20	2025/02/19
Cable-0.5m(1G-26.5G)	HUBER SUHNER	SUCOFLEX 102	28422/2	2024/5/13	2025/05/12
Power Meter	Anritsu	ML2495A	1224005	2024/02/17	2025/02/16
Power Sensor	Anritsu	MA2411B	1207295	2024/02/17	2025/02/16
Switch Box	Theda	1-4	TW5451159	NA	NA



Non-Beamforming:

Test Item	AC Power Line Conducted Emission				
Test Site	CON02-NK				
Instrument	Manufacturer	Model No	Serial No	Calibration Date	Valid Date
EMI Receiver	ROHDE & SCHWARZ	ESR 7	101906	2024/05/13	2025/05/12
Two-Line V-Network	ROHDE & SCHWARZ	ENV216	102185	2024/08/27	2025/08/26
Line Impedance Stabilization Network	Schwarzbeck	NSLK 8127	8127740	2024/08/27	2025/08/26
Cable-4m(9k-3G)	EMEC	RG-223	18274M	2024/08/08	2025/08/07
E3	AUDIX	v8.2014-8-6	RK-000536	NA	NA

Beamforming:

Test Item	RF Conducted(2025/01/11-2025/01/13)				
Test Site	RFCON01-NK				
Instrument	Manufacturer	Model No	Serial No	Calibration Date	Valid Date
Spectrum Analyzer	ROHDE & SCHWARZ	FSP 40	100047	2024/03/01	2025/02/28
Attenuator	KEYSIGHT	8491B	MY39250703	2024/02/20	2025/02/19
Cable-0.5m(1G-26.5G)	HUBER SUHNER	SUCOFLEX 102	28422/2	2024/5/13	2025/05/12
Power Meter	Anritsu	ML2495A	1224005	2024/02/17	2025/02/16
Power Sensor	Anritsu	MA2411B	1207295	2024/02/17	2025/02/16
Switch Box	Theda	1-4	TW5451159	NA	NA

Test Item	RF Conducted(2025/05/05~2025/05/23)				
Test Site	RFCON01-NK				
Instrument	Manufacturer	Model No	Serial No	Calibration Date	Valid Date
Spectrum Analyzer	ROHDE & SCHWARZ	FSP 40	100047	2025/03/03	2026/03/02
Attenuator	KEYSIGHT	8491B	MY39250703	2025/02/12	2026/02/11
Cable-0.5m(30M-40G)	HUBER SUHNER	SUCOFLEX 102	28420/2	2024/10/24	2025/10/23
Power Meter	Anritsu	ML2495A	1224005	2025/02/12	2026/02/11
Power Sensor	Anritsu	MA2411B	1207295	2025/02/12	2026/02/11
Switch Box	Theda	1-4	TW5451159	NA	NA



## 4. Antenna Requirements

### 4.1. Standard Applicable

For intentional device, according to FCC 47 CFR Section 15.203, an intentional radiator shall be designed to ensure that no antenna other than that furnished by the responsible party shall be used with the device.

And according to FCC 47 CFR Section 15.407 (a), if transmitting antennas of directional gain greater than 6dBi are used, the power shall be reduced by the amount in dB that the directional gain of the antenna exceeds 6dBi.



### 4.2. Antenna Construction and Directional Gain

Antenna Type	Dipole Antenna
Antenna Gain	5150-5250MHz: ANT A 1.48dBi, ANT D: 0.74dBi 5250-5350MHz: ANT A 1.11dBi, ANT D: 1.28dBi 5470-5725MHz: ANT A 1.37dBi, ANT D: 1.47dBi 5725-5850MHz: ANT A 1.37dBi, ANT D: 1.88dBi

(Non-Beamforming)

5150-5250MHz
For Power directional gain= $G_{ant}= 1.48$ dBi For PSD directional gain = $10 \log[(10^{G1/20} + 10^{G2/20} + \dots + 10^{GN/20})^2 / N_{ANT}]$ = 4.13 (dBi)
5250-5350MHz
For Power directional gain= $G_{ant}= 1.28$ dBi For PSD directional gain = $10 \log[(10^{G1/20} + 10^{G2/20} + \dots + 10^{GN/20})^2 / N_{ANT}]$ = 4.21 (dBi)
5470-5725MHz
For Power directional gain= $G_{ant}= 1.47$ dBi For PSD directional gain = $10 \log[(10^{G1/20} + 10^{G2/20} + \dots + 10^{GN/20})^2 / N_{ANT}]$ = 4.43 (dBi)
5725-5850MHz
For Power directional gain= $G_{ant}= 1.88$ dBi For PSD directional gain = $10 \log[(10^{G1/20} + 10^{G2/20} + \dots + 10^{GN/20})^2 / N_{ANT}]$ = 4.64 (dBi)

\*MIMO type: Cyclic Delay Diversity (CDD) mode.

(Beamforming)

5150-5250MHz
For Power directional gain= 4.13 dBi For PSD directional gain = 4.13 (dBi)
5250-5350MHz
For Power directional gain= 4.21 dBi For PSD directional gain = 4.21 (dBi)
5470-5725MHz
For Power directional gain= 4.43 dBi For PSD directional gain = 4.43 (dBi)
5725-5850MHz
For Power directional gain= 4.64 dBi For PSD directional gain = 4.64 (dBi)



## 5. Test of AC Power Line Conducted Emission

### 5.1. Test Limit

Conducted Emissions were measured from 150 kHz to 30 MHz with a bandwidth of 9 KHz, according to the methods defined in ANSI C63.10-2013. The EUT was placed on a nonmetallic stand in a shielded room 0.8 meters above the ground plane. The interface cables and equipment positioning were varied within limits of reasonable applications to determine the position produced maximum conducted emissions.

Frequency (MHz)	Quasi Peak (dB $\mu$ V)	Average (dB $\mu$ V)
0.15 – 0.5	66-56*	56-46*
0.5 – 5.0	56	46
5.0 – 30.0	60	50

\*Decreases with the logarithm of the frequency.

### 5.2. Test Procedures

- a. The EUT was placed 0.4 meter from the conducting wall of the shielding room was kept at least 80 centimeters from any other grounded conducting surface.
- b. Connect EUT to the power mains through a line impedance stabilization network (LISN).
- c. All the support units are connecting to the other LISN.
- d. The LISN provides 50 ohm coupling impedance for the measuring instrument.
- e. The FCC states that a 50 ohm, 50 micro-Henry LISN should be used.
- f. Both sides of AC line were checked for maximum conducted interference.
- g. The frequency range from 150 kHz to 30 MHz was searched.
- h. Set the test-receiver system to Peak Detect Function and Specified Bandwidth with Maximum Hold Mode.



### 5.3. Typical Test Setup

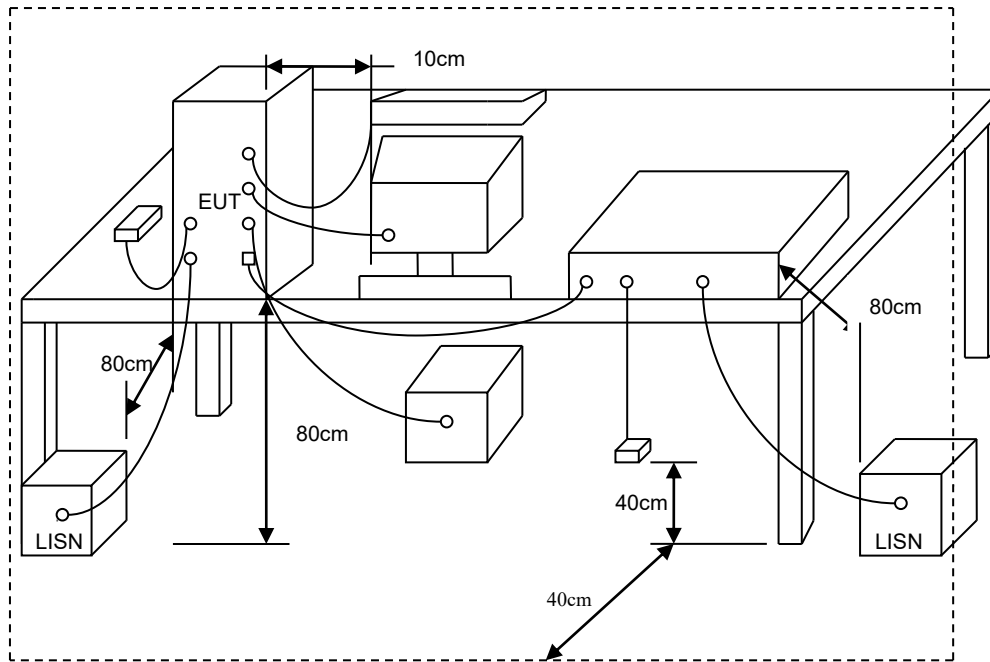



### 5.4. Test Result and Data

Test Mode : 2TX 11be20 CH165 NSS1 MCS0  
Voltage : From Adapter(AC 120V/60Hz)  
Phase : Line

Data: 34

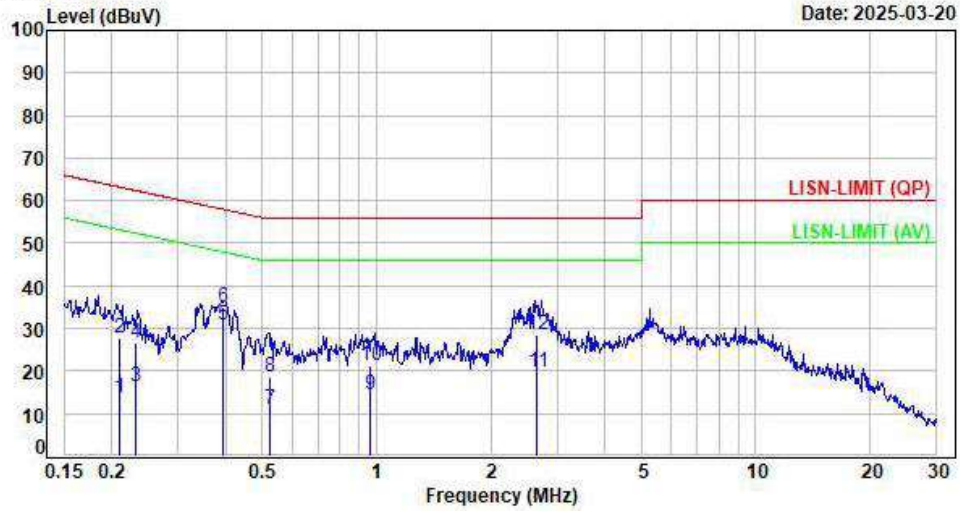

No.	Frequency (MHz)	Factor (dB)	Reading (dBuV)	Level (dBuV)	Limit (dBuV)	Margin (dB)	Detector	P/F
1	0.2099	9.63	4.10	13.73	53.21	-39.48	Average	P
2	0.2099	9.63	17.95	27.58	63.21	-35.63	QP	P
3	0.2311	9.63	6.79	16.42	52.41	-35.99	Average	P
4	0.2311	9.63	17.09	26.72	62.41	-35.69	QP	P
5	0.3936	9.65	21.20	30.85	47.99	-17.14	Average	P
6	0.3936	9.65	25.28	34.93	57.99	-23.06	QP	P
7	0.5233	9.65	1.38	11.03	46.00	-34.97	Average	P
8	0.5233	9.65	8.93	18.58	56.00	-37.42	QP	P
9	0.9595	9.66	4.73	14.39	46.00	-31.61	Average	P
10	0.9595	9.66	11.76	21.42	56.00	-34.58	QP	P
11	2.6567	9.71	9.95	19.66	46.00	-26.34	Average	P
12	2.6567	9.71	18.62	28.33	56.00	-27.67	QP	P

Note: Level=Reading+Factor  
Margin=Level-Limit  
Factor=(LISN or ISN or Current Probe)Factor + Cable Loss



Test Mode : 2TX 11be20 CH165 NSS1 MCS0  
Voltage : From Adapter(AC 120V/60Hz)  
Phase : Neutral

Data: 35

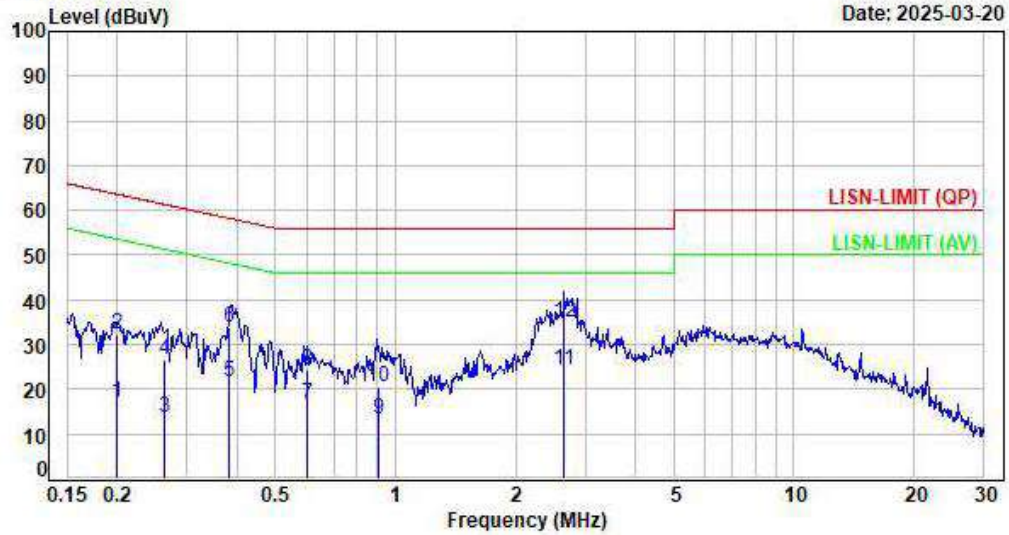

No.	Frequency (MHz)	Factor (dB)	Reading (dBuV)	Level (dBuV)	Limit (dBuV)	Margin (dB)	Detector	P/F
1	0.1998	9.61	7.44	17.05	53.62	-36.57	Average	P
2	0.1998	9.61	22.69	32.30	63.62	-31.32	QP	P
3	0.2642	9.61	3.97	13.58	51.30	-37.72	Average	P
4	0.2642	9.61	16.99	26.60	61.30	-34.70	QP	P
5	0.3818	9.62	12.10	21.72	48.24	-26.52	Average	P
6	0.3818	9.62	24.23	33.85	58.24	-24.39	QP	P
7	0.6008	9.63	7.04	16.67	46.00	-29.33	Average	P
8	0.6008	9.63	14.53	24.16	56.00	-31.84	QP	P
9	0.9030	9.65	3.71	13.36	46.00	-32.64	Average	P
10	0.9030	9.65	10.87	20.52	56.00	-35.48	QP	P
11	2.6481	9.69	14.67	24.36	46.00	-21.64	Average	P
12	2.6481	9.69	25.43	35.12	56.00	-20.88	QP	P

Note: Level=Reading+Factor  
Margin=Level-Limit  
Factor=(LISN or ISN or Current Probe)Factor + Cable Loss



## 6. Test of Spurious Emission (Radiated)

### 6.1. Test Limit

Undesirable emission limits. Except as shown in paragraph (b)(7) of this section, the maximum emissions outside of the frequency bands of operation shall be attenuated in accordance with the following limits:

- (1) For transmitters operating in the 5.15-5.25 GHz band: All emissions outside of the 5.15-5.35 GHz band shall not exceed an e.i.r.p. of  $-27$  dBm/MHz.
- (2) For transmitters operating in the 5.25-5.35 GHz band: All emissions outside of the 5.15-5.35 GHz band shall not exceed an e.i.r.p. of  $-27$  dBm/MHz.
- (3) For transmitters operating in the 5.47-5.725 GHz band: All emissions outside of the 5.47-5.725 GHz band shall not exceed an e.i.r.p. of  $-27$  dBm/MHz.
- (4) For transmitters operating in the 5.725-5.85 GHz band:  
All emissions shall be limited to a level of  $-27$  dBm/MHz at 75 MHz or more above or below the band edge increasing linearly to 10 dBm/MHz at 25 MHz above or below the band edge, and from 25MHz above or below the band edge increasing linearly to a level of 15.6 dBm/MHz at 5 MHz above or below the band edge, and from 5 MHz above or below the band edge increasing linearly to a level of 27dBm/MHz at the band edge.
- (5) The emission measurements shall be performed using a minimum resolution bandwidth of 1 MHz. A lower resolution bandwidth may be employed near the band edge, when necessary, provided the measured energy is integrated to show the total power over 1 MHz.
- (6) Unwanted emissions below 1 GHz must comply with the general field strength limits set forth in §15.209. Further, any U-NII devices using an AC power line are required to comply also with the conducted limits set forth in §15.207.
- (7) The provisions of §15.205 apply to intentional radiators operating under this section.
- (8) When measuring the emission limits, the nominal carrier frequency shall be adjusted as close to the upper and lower frequency band edges as the design of the equipment permits.



## 6.2. Test Procedures

- a. The EUT was placed on a rotatable table top 0.8 meter above ground.
- b. The EUT was set 3 meters from the interference receiving antenna which was mounted on the top of a variable height antenna tower.
- c. The table was rotated 360 degrees to determine the position of the highest radiation.
- d. The antenna is a broadband antenna and its height is varied between one meter and four meters above ground to find the maximum value of the field strength both horizontal polarization and vertical polarization of the antenna are set to make the measurement.
- e. For each suspected emission the EUT was arranged to its worst case and then tune the antenna tower (from 1 M to 4 M) and turn table (from 0 degree to 360 degrees) to find the maximum reading.
- f. Set the test-receiver system to Peak or CISPR quasi-peak Detect Function and specified bandwidth with Maximum Hold Mode.
- g. If the emission level of the EUT in peak mode was 3 dB lower than the limit specified, then testing will be stopped and peak values of EUT will be reported, otherwise, the emissions which do not have 3 dB margin will be repeated one by one using the quasi-peak method and reported.
- h. For testing above 1GHz, the emission level of the EUT in peak mode was 20dB lower than average limit (that means the emission level in peak mode also complies with the limit in average mode), then testing will be stopped and peak values of EUT will be reported, otherwise, the emissions will be measured in average mode again and reported.
- i. "Cone of radiation" has been considered to be 3dB bandwidth of the measurement antenna.

Note:

- 1.The supporting fixture shall permit orientation of the EUT in each of three orthogonal axis positions such that emissions from the EUT are maximized.
- 2.Due to the test software function limit the operation band setting(200dBuV/m). There's no corresponding limitation in the actual test item.



### 6.3. Typical Test Setup

Below 30MHz test setup

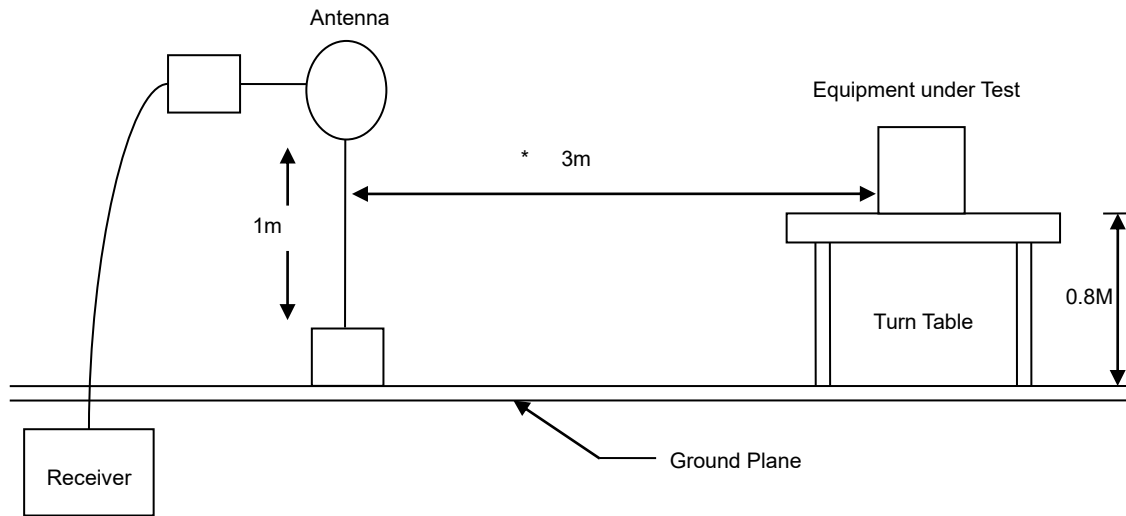

30MHz- 1GHz Test Setup

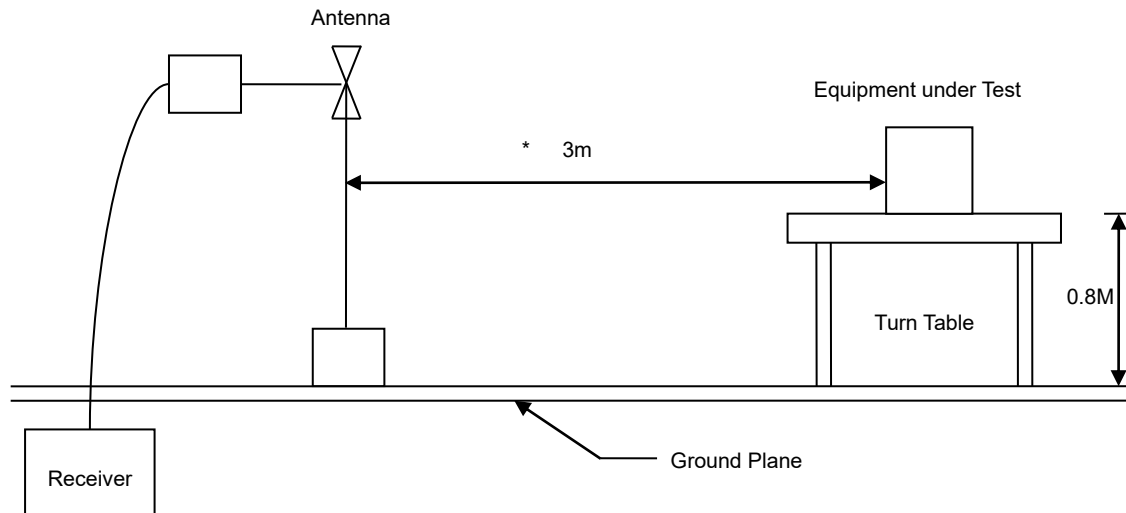

Above 1GHz Test Setup

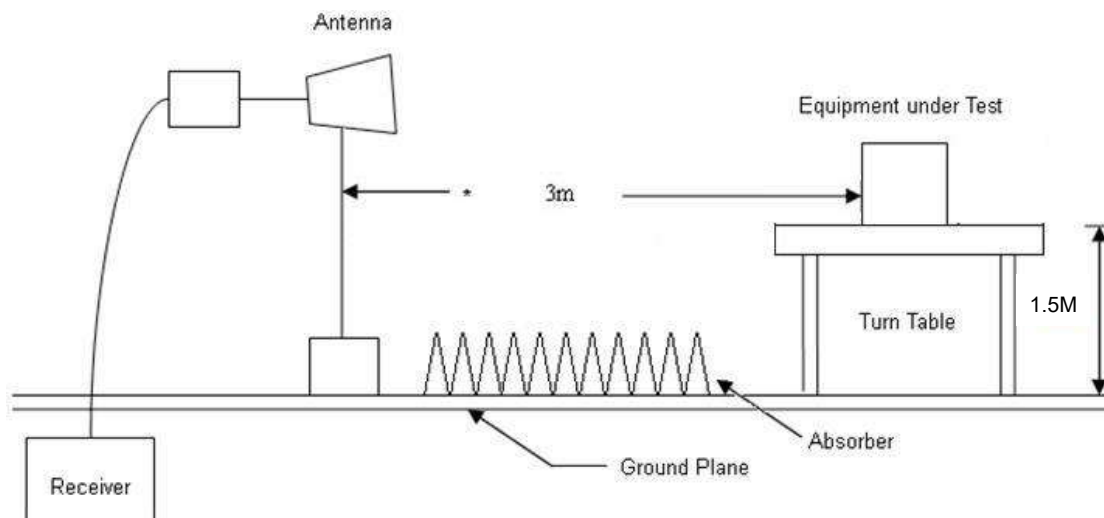



### 6.4. Test Result and Data (9kHz ~ 30MHz)

The 9kHz - 30MHz spurious emission is under limit 20dB more.

### 6.5. Test Result and Data (30MHz ~ 1GHz)

Test Mode : 2TX 11be20 CH165 NSS1 MCS0  
Voltage : From Adapter(AC120V/60Hz)  
Pol : Vertical

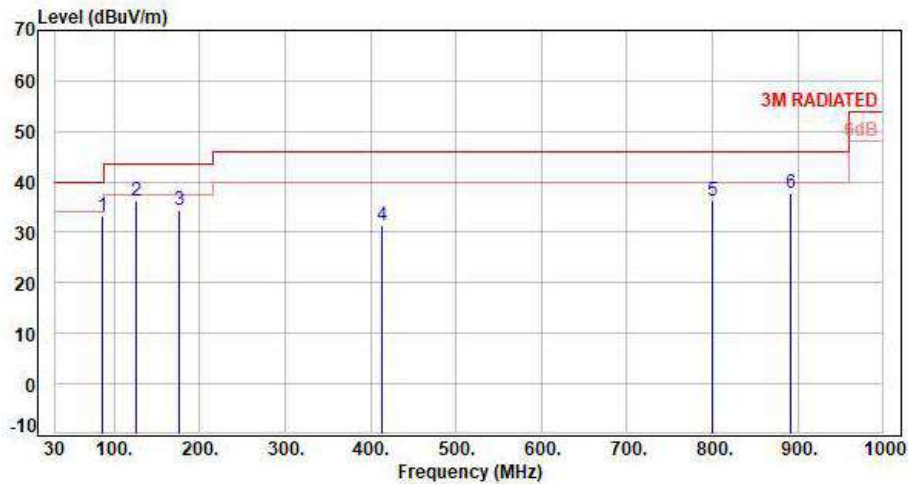

No.	Frequency (MHz)	Factor (dB)	Reading (dBuV)	Level (dBuV/m)	Limit (dBuV/m)	Margin (dB)	Detector	Height (cm)	Azimuth (deg)	P/F
1	86.26	-15.73	49.01	33.28	40.00	-6.72	QP	123	54	P
2	125.06	-12.02	48.19	36.17	43.50	-7.33	Peak	400	360	P
3	175.50	-10.30	44.77	34.47	43.50	-9.03	Peak	400	360	P
4	414.12	-4.70	36.08	31.38	46.00	-14.62	Peak	400	360	P
5	800.18	3.16	32.93	36.09	46.00	-9.91	Peak	400	360	P
6	891.36	4.44	33.20	37.64	46.00	-8.36	Peak	400	360	P

Note: Level=Reading+Factor  
Margin=Level-Limit  
Factor=Antenna Factor + cable loss - Amplifier Factor



Test Mode : 2TX 11be20 CH165 NSS1 MCS0  
Voltage : From Adapter(AC120V/60Hz)  
Pol : Horizontal

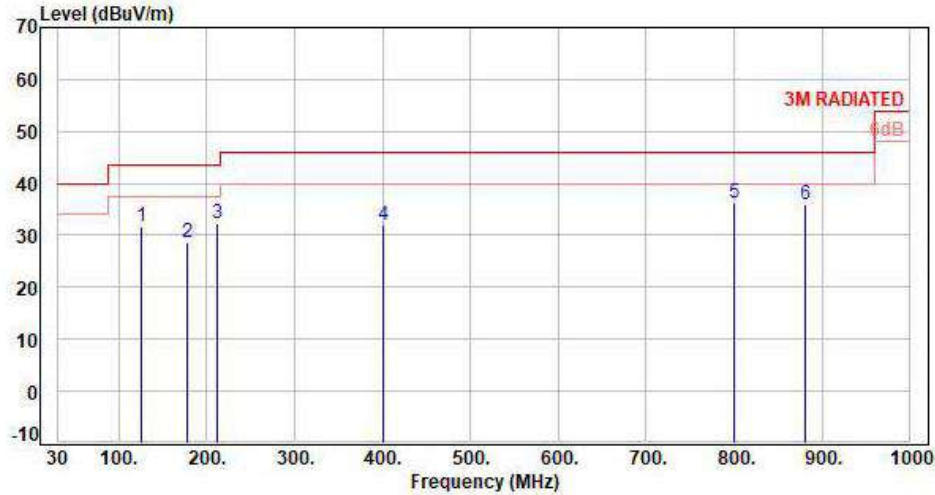

No.	Frequency (MHz)	Factor (dB)	Reading (dBuV)	Level (dBuV/m)	Limit (dBuV/m)	Margin (dB)	Detector	Height (cm)	Azimuth (deg)	P/F
1	125.06	-12.02	43.70	31.68	43.50	-11.82	Peak	400	0	P
2	177.44	-10.58	39.07	28.49	43.50	-15.01	Peak	400	0	P
3	212.36	-12.44	44.69	32.25	43.50	-11.25	Peak	400	0	P
4	400.54	-5.01	36.85	31.84	46.00	-14.16	Peak	400	0	P
5	800.18	3.16	32.97	36.13	46.00	-9.87	Peak	400	0	P
6	881.66	4.37	31.41	35.78	46.00	-10.22	Peak	400	0	P

Note: Level=Reading+Factor  
 Margin=Level-Limit  
 Factor=Antenna Factor + cable loss - Amplifier Factor



### 6.6. Test Result and Data (1GHz ~ 40GHz)

Test Mode : 2TX 11a CH36 6Mbps  
Voltage : From Adapter(AC120V/60Hz)  
Pol : Vertical

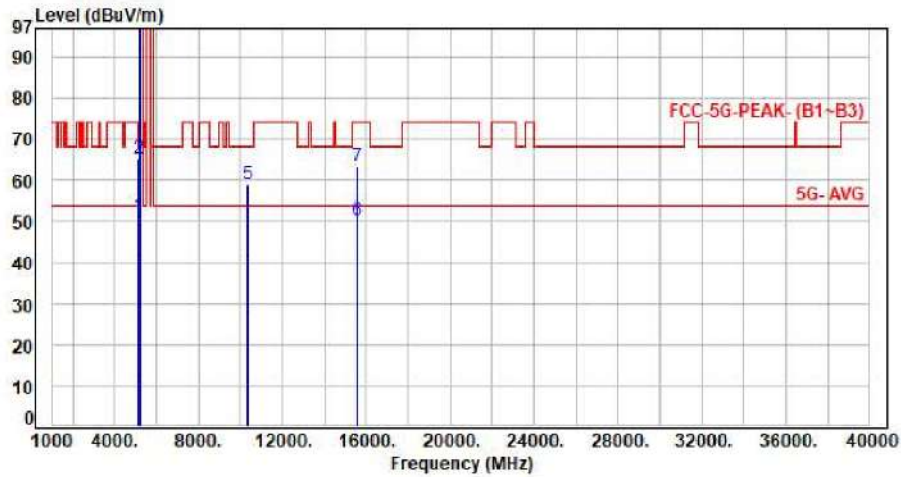

No.	Frequency (MHz)	Factor (dB)	Reading (dBuV)	Level (dBuV/m)	Limit (dBuV/m)	Margin (dB)	Detector	Height (cm)	Azimuth (deg)	P/F
1	5150.00	7.18	44.17	51.35	54.00	-2.65	Average	125	59	P
2	5150.00	7.18	57.98	65.16	74.00	-8.84	Peak	125	59	P
3	5180.00	7.25	94.84	102.09	200.00	-97.91	Average	125	59	P
4	5180.00	7.25	104.85	112.10	200.00	-87.90	Peak	125	59	P
5	10360.00	15.21	43.69	58.90	68.20	-9.30	Peak	100	156	P
6	15540.00	19.80	30.21	50.01	54.00	-3.99	Average	100	227	P
7	15540.00	19.80	43.77	63.57	74.00	-10.43	Peak	100	227	P

Note: Level=Reading+Factor  
Margin=Level-Limit  
Factor=Antenna Factor + cable loss - Amplifier Factor



Test Mode : 2TX 11a CH36 6Mbps  
Voltage : From Adapter(AC120V/60Hz)  
Pol : Horizontal

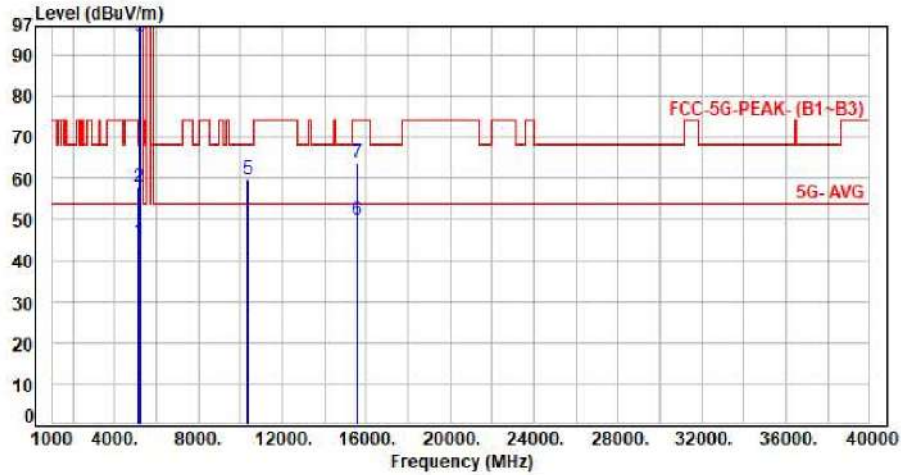

No.	Frequency (MHz)	Factor (dB)	Reading (dBuV)	Level (dBuV/m)	Limit (dBuV/m)	Margin (dB)	Detector	Height (cm)	Azimuth (deg)	P/F
1	5150.00	7.18	37.32	44.50	54.00	-9.50	Average	112	30	P
2	5150.00	7.18	50.76	57.94	74.00	-16.06	Peak	112	30	P
3	5180.00	7.25	87.09	94.34	200.00	-105.66	Average	112	30	P
4	5180.00	7.25	97.19	104.44	200.00	-95.56	Peak	112	30	P
5	10360.00	15.21	44.72	59.93	68.20	-8.27	Peak	100	28	P
6	15540.00	19.80	29.83	49.63	54.00	-4.37	Average	100	144	P
7	15540.00	19.80	43.95	63.75	74.00	-10.25	Peak	100	144	P

Note: Level=Reading+Factor  
Margin=Level-Limit  
Factor=Antenna Factor + cable loss - Amplifier Factor



Test Mode : 2TX 11a CH40 6Mbps  
Voltage : From Adapter(AC120V/60Hz)  
Pol : Vertical

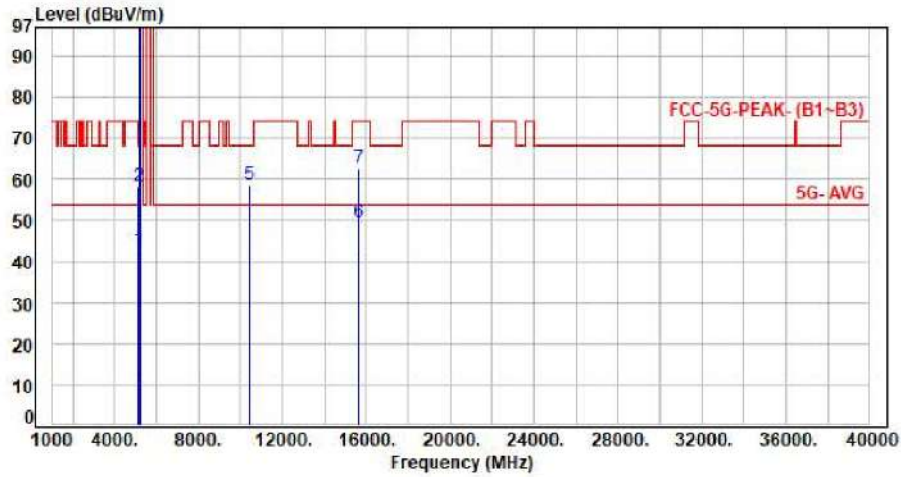

No.	Frequency (MHz)	Factor (dB)	Reading (dBuV)	Level (dBuV/m)	Limit (dBuV/m)	Margin (dB)	Detector	Height (cm)	Azimuth (deg)	P/F
1	5150.00	7.18	35.43	42.61	54.00	-11.39	Average	106	56	P
2	5150.00	7.18	50.98	58.16	74.00	-15.84	Peak	106	56	P
3	5200.00	7.30	94.73	102.03	200.00	-97.97	Average	106	56	P
4	5200.00	7.30	104.89	112.19	200.00	-87.81	Peak	106	56	P
5	10400.00	15.16	43.65	58.81	68.20	-9.39	Peak	100	154	P
6	15600.00	19.45	29.83	49.28	54.00	-4.72	Average	100	225	P
7	15600.00	19.45	43.28	62.73	74.00	-11.27	Peak	100	225	P

Note: Level=Reading+Factor  
Margin=Level-Limit  
Factor=Antenna Factor + cable loss - Amplifier Factor



Test Mode : 2TX 11a CH40 6Mbps  
Voltage : From Adapter(AC120V/60Hz)  
Pol : Horizontal

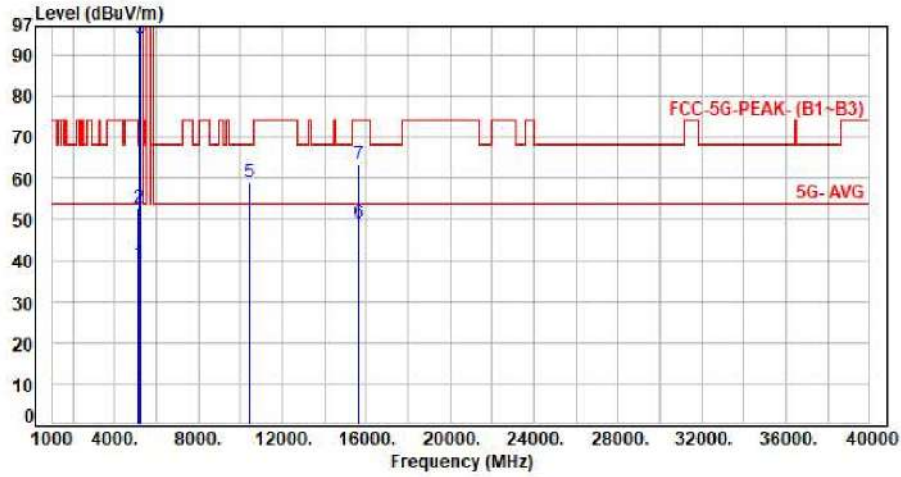

No.	Frequency (MHz)	Factor (dB)	Reading (dBuV)	Level (dBuV/m)	Limit (dBuV/m)	Margin (dB)	Detector	Height (cm)	Azimuth (deg)	P/F
1	5150.00	7.18	31.94	39.12	54.00	-14.88	Average	171	31	P
2	5150.00	7.18	45.47	52.65	74.00	-21.35	Peak	171	31	P
3	5200.00	7.30	86.61	93.91	200.00	-106.09	Average	171	31	P
4	5200.00	7.30	96.85	104.15	200.00	-95.85	Peak	171	31	P
5	10400.00	15.16	43.76	58.92	68.20	-9.28	Peak	100	28	P
6	15600.00	19.45	29.69	49.14	54.00	-4.86	Average	100	148	P
7	15600.00	19.45	44.15	63.60	74.00	-10.40	Peak	100	148	P

Note: Level=Reading+Factor  
Margin=Level-Limit  
Factor=Antenna Factor + cable loss - Amplifier Factor



Test Mode : 2TX 11a CH48 6Mbps  
Voltage : From Adapter(AC120V/60Hz)  
Pol : Vertical

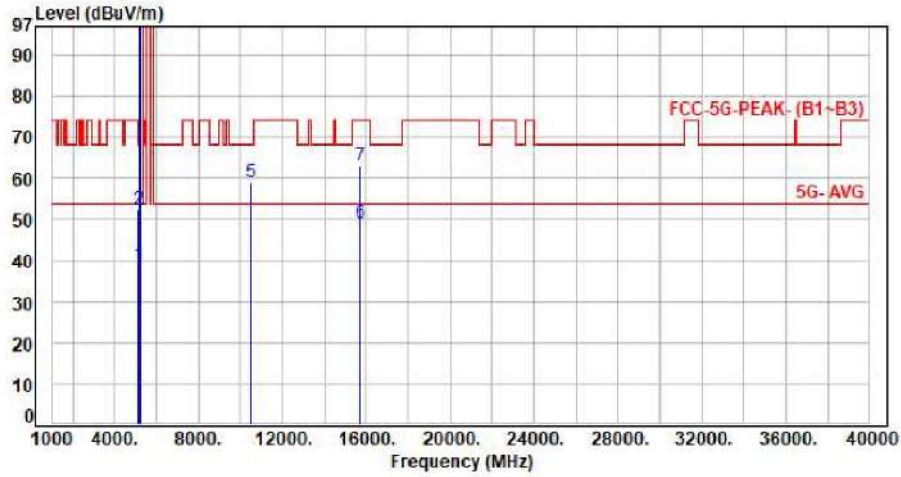

No.	Frequency (MHz)	Factor (dB)	Reading (dBuV)	Level (dBuV/m)	Limit (dBuV/m)	Margin (dB)	Detector	Height (cm)	Azimuth (deg)	P/F
1	5150.00	7.18	31.58	38.76	54.00	-15.24	Average	128	336	P
2	5150.00	7.18	45.21	52.39	74.00	-21.61	Peak	128	336	P
3	5240.00	7.32	95.78	103.10	200.00	-96.90	Average	128	336	P
4	5240.00	7.32	105.67	112.99	200.00	-87.01	Peak	128	336	P
5	10480.00	15.44	43.69	59.13	68.20	-9.07	Peak	100	156	P
6	15720.00	19.61	29.59	49.20	54.00	-4.80	Average	100	228	P
7	15720.00	19.61	43.46	63.07	74.00	-10.93	Peak	100	228	P

Note: Level=Reading+Factor  
Margin=Level-Limit  
Factor=Antenna Factor + cable loss - Amplifier Factor



Test Mode : 2TX 11a CH48 6Mbps  
 Voltage : From Adapter(AC120V/60Hz)  
 Pol : Horizontal

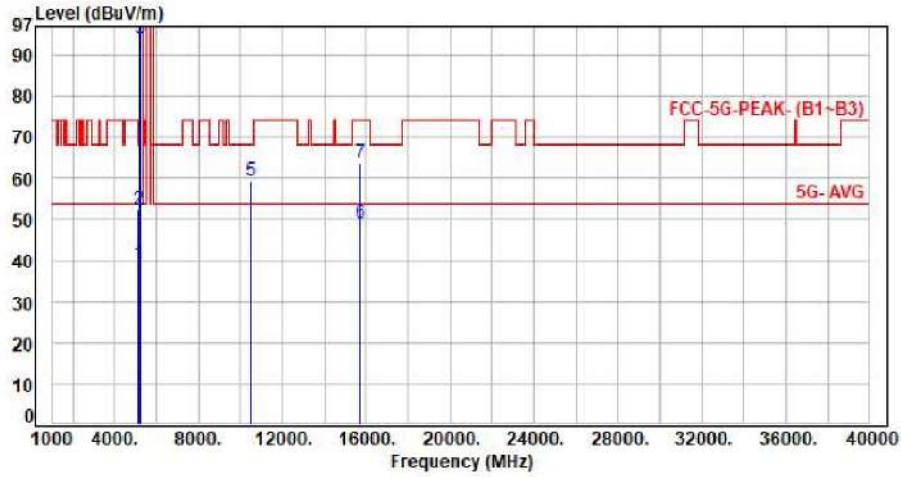

No.	Frequency (MHz)	Factor (dB)	Reading (dBuV)	Level (dBuV/m)	Limit (dBuV/m)	Margin (dB)	Detector	Height (cm)	Azimuth (deg)	P/F
1	5150.00	7.18	31.73	38.91	54.00	-15.09	Average	126	32	P
2	5150.00	7.18	45.05	52.23	74.00	-21.77	Peak	126	32	P
3	5240.00	7.32	86.55	93.87	200.00	-106.13	Average	126	32	P
4	5240.00	7.32	96.92	104.24	200.00	-95.76	Peak	126	32	P
5	10480.00	15.44	43.85	59.29	68.20	-8.91	Peak	100	26	P
6	15720.00	19.61	29.48	49.09	54.00	-4.91	Average	100	149	P
7	15720.00	19.61	44.16	63.77	74.00	-10.23	Peak	100	149	P

Note: Level=Reading+Factor  
 Margin=Level-Limit  
 Factor=Antenna Factor + cable loss - Amplifier Factor



Test Mode : 2TX 11be EHT20 CH36 NSS1 MCS0  
Voltage : From Adapter(AC120V/60Hz)  
Pol : Vertical

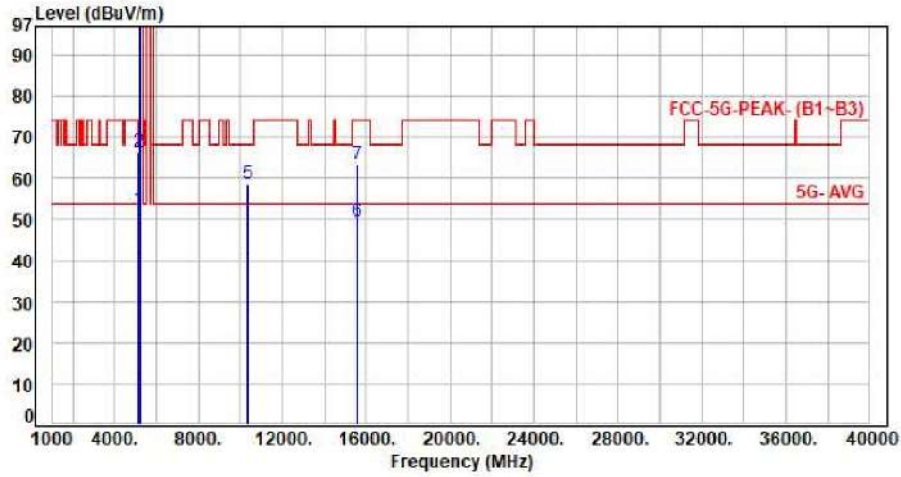

No.	Frequency (MHz)	Factor (dB)	Reading (dBuV)	Level (dBuV/m)	Limit (dBuV/m)	Margin (dB)	Detector	Height (cm)	Azimuth (deg)	P/F
1	5150.00	7.18	45.07	52.25	54.00	-1.75	Average	100	300	P
2	5150.00	7.18	59.19	66.37	74.00	-7.63	Peak	100	300	P
3	5180.00	7.25	95.00	102.25	200.00	-97.75	Average	100	300	P
4	5180.00	7.25	106.67	113.92	200.00	-86.08	Peak	100	300	P
5	10360.00	15.21	43.60	58.81	68.20	-9.39	Peak	100	154	P
6	15540.00	19.80	29.63	49.43	54.00	-4.57	Average	100	225	P
7	15540.00	19.80	43.58	63.38	74.00	-10.62	Peak	100	225	P

Note: Level=Reading+Factor  
Margin=Level-Limit  
Factor=Antenna Factor + cable loss - Amplifier Factor



Test Mode : 2TX 11be EHT20 CH36 NSS1 MCS0  
Voltage : From Adapter(AC120V/60Hz)  
Pol : Horizontal

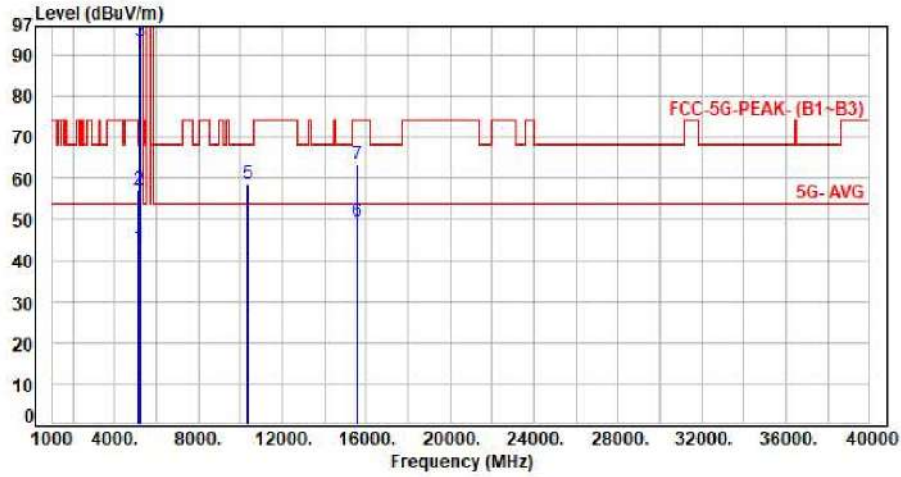

No.	Frequency (MHz)	Factor (dB)	Reading (dBuV)	Level (dBuV/m)	Limit (dBuV/m)	Margin (dB)	Detector	Height (cm)	Azimuth (deg)	P/F
1	5150.00	7.18	36.10	43.28	54.00	-10.72	Average	132	34	P
2	5150.00	7.18	50.05	57.23	74.00	-16.77	Peak	132	34	P
3	5180.00	7.25	86.24	93.49	200.00	-106.51	Average	132	34	P
4	5180.00	7.25	98.04	105.29	200.00	-94.71	Peak	132	34	P
5	10360.00	15.21	43.37	58.58	68.20	-9.62	Peak	100	28	P
6	15540.00	19.80	29.68	49.48	54.00	-4.52	Average	100	147	P
7	15540.00	19.80	43.71	63.51	74.00	-10.49	Peak	100	147	P

Note: Level=Reading+Factor  
Margin=Level-Limit  
Factor=Antenna Factor + cable loss - Amplifier Factor



Test Mode : 2TX 11be EHT20 CH40 NSS1 MCS0  
Voltage : From Adapter(AC120V/60Hz)  
Pol : Vertical

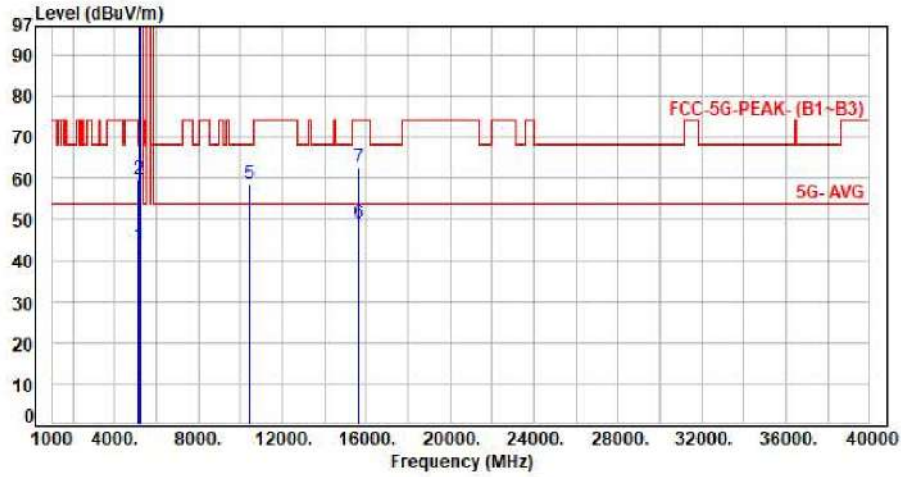

No.	Frequency (MHz)	Factor (dB)	Reading (dBuV)	Level (dBuV/m)	Limit (dBuV/m)	Margin (dB)	Detector	Height (cm)	Azimuth (deg)	P/F
1	5150.00	7.18	36.37	43.55	54.00	-10.45	Average	268	237	P
2	5150.00	7.18	52.71	59.89	74.00	-14.11	Peak	268	237	P
3	5200.00	7.30	94.80	102.10	200.00	-97.90	Average	268	237	P
4	5200.00	7.30	106.97	114.27	200.00	-85.73	Peak	268	237	P
5	10400.00	15.16	43.63	58.79	68.20	-9.41	Peak	100	154	P
6	15600.00	19.45	29.52	48.97	54.00	-5.03	Average	100	229	P
7	15600.00	19.45	43.20	62.65	74.00	-11.35	Peak	100	229	P

Note: Level=Reading+Factor  
Margin=Level-Limit  
Factor=Antenna Factor + cable loss - Amplifier Factor



Test Mode : 2TX 11be EHT20 CH40 NSS1 MCS0  
Voltage : From Adapter(AC120V/60Hz)  
Pol : Horizontal

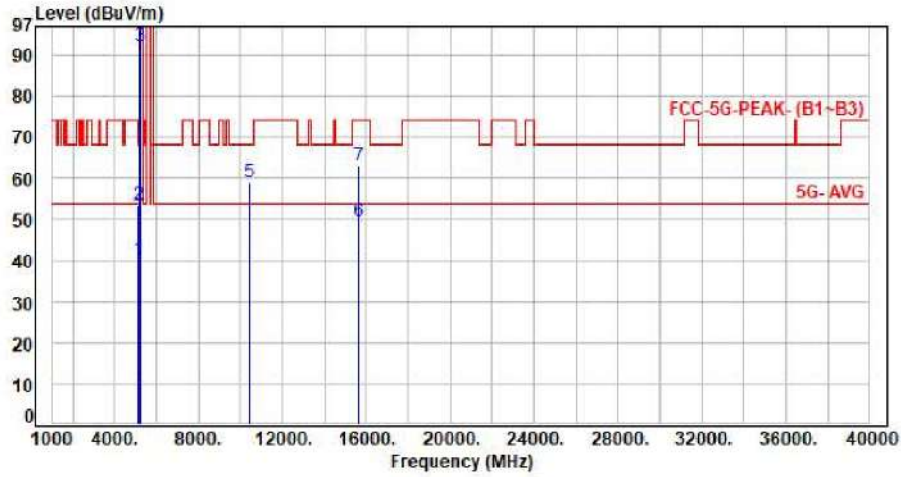

No.	Frequency (MHz)	Factor (dB)	Reading (dBuV)	Level (dBuV/m)	Limit (dBuV/m)	Margin (dB)	Detector	Height (cm)	Azimuth (deg)	P/F
1	5150.00	7.18	33.14	40.32	54.00	-13.68	Average	170	30	P
2	5150.00	7.18	46.24	53.42	74.00	-20.58	Peak	170	30	P
3	5200.00	7.30	84.87	92.17	200.00	-107.83	Average	170	30	P
4	5200.00	7.30	97.77	105.07	200.00	-94.93	Peak	170	30	P
5	10400.00	15.16	44.03	59.19	68.20	-9.01	Peak	100	26	P
6	15600.00	19.45	29.82	49.27	54.00	-4.73	Average	100	145	P
7	15600.00	19.45	43.57	63.02	74.00	-10.98	Peak	100	145	P

Note: Level=Reading+Factor  
Margin=Level-Limit  
Factor=Antenna Factor + cable loss - Amplifier Factor



Test Mode : 2TX 11be EHT20 CH48 NSS1 MCS0  
 Voltage : From Adapter(AC120V/60Hz)  
 Pol : Vertical

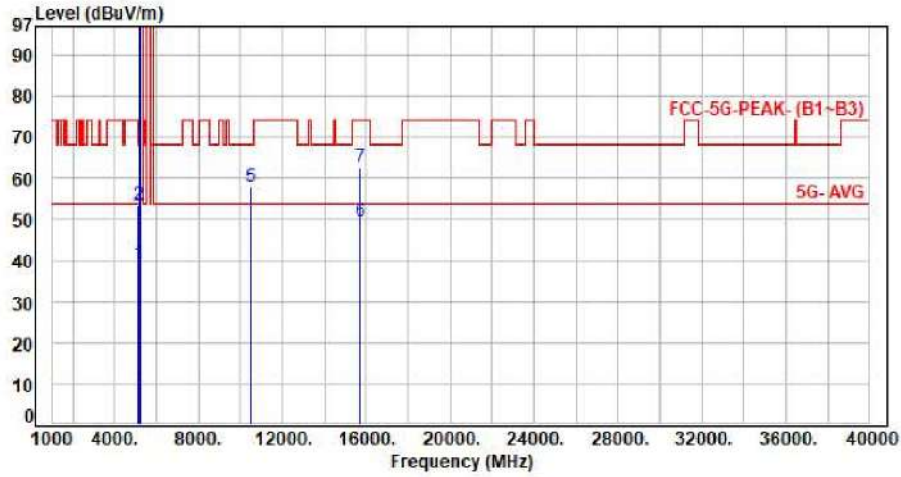

No.	Frequency (MHz)	Factor (dB)	Reading (dBuV)	Level (dBuV/m)	Limit (dBuV/m)	Margin (dB)	Detector	Height (cm)	Azimuth (deg)	P/F
1	5150.00	7.18	32.00	39.18	54.00	-14.82	Average	127	340	P
2	5150.00	7.18	46.26	53.44	74.00	-20.56	Peak	127	340	P
3	5240.00	7.32	95.26	102.58	200.00	-97.42	Average	127	340	P
4	5240.00	7.32	107.97	115.29	200.00	-84.71	Peak	127	340	P
5	10480.00	15.44	42.52	57.96	68.20	-10.24	Peak	100	156	P
6	15720.00	19.61	29.69	49.30	54.00	-4.70	Average	100	227	P
7	15720.00	19.61	43.15	62.76	74.00	-11.24	Peak	100	227	P

Note: Level=Reading+Factor  
 Margin=Level-Limit  
 Factor=Antenna Factor + cable loss - Amplifier Factor



Test Mode : 2TX 11be EHT20 CH48 NSS1 MCS0  
Voltage : From Adapter(AC120V/60Hz)  
Pol : Horizontal

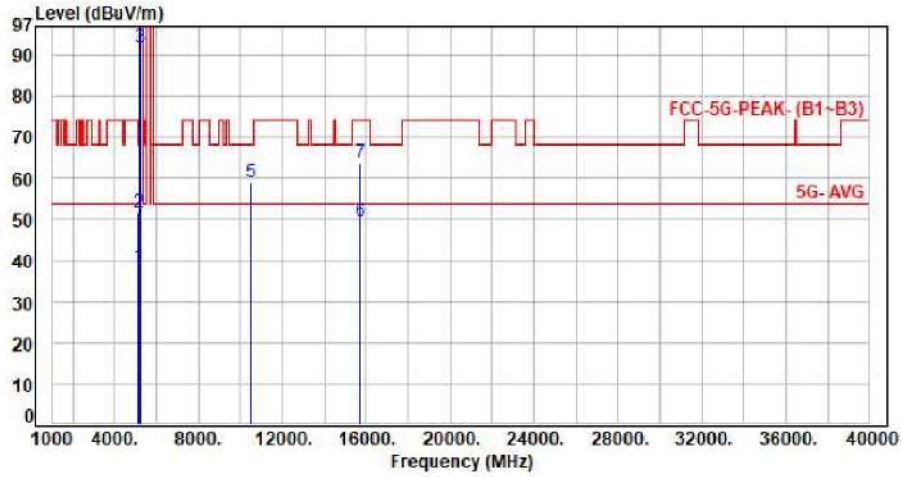

No.	Frequency (MHz)	Factor (dB)	Reading (dBuV)	Level (dBuV/m)	Limit (dBuV/m)	Margin (dB)	Detector	Height (cm)	Azimuth (deg)	P/F
1	5150.00	7.18	31.17	38.35	54.00	-15.65	Average	128	31	P
2	5150.00	7.18	44.45	51.63	74.00	-22.37	Peak	128	31	P
3	5240.00	7.32	84.56	91.88	200.00	-108.12	Average	128	31	P
4	5240.00	7.32	97.94	105.26	200.00	-94.74	Peak	128	31	P
5	10480.00	15.44	43.61	59.05	68.20	-9.15	Peak	100	28	P
6	15720.00	19.61	29.66	49.27	54.00	-4.73	Average	100	146	P
7	15720.00	19.61	44.28	63.89	74.00	-10.11	Peak	100	146	P

Note: Level=Reading+Factor  
Margin=Level-Limit  
Factor=Antenna Factor + cable loss - Amplifier Factor



Test Mode : 2TX 11be EHT40 CH38 NSS1 MCS0  
Voltage : From Adapter(AC120V/60Hz)  
Pol : Vertical

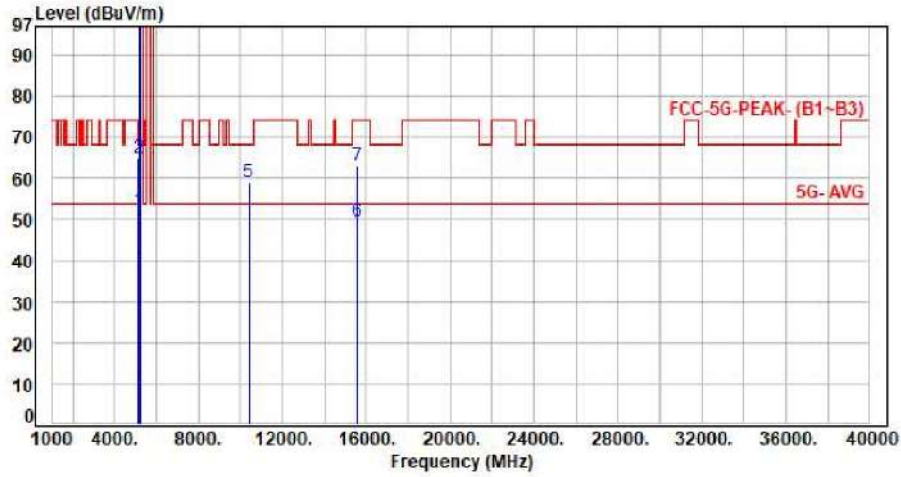

No.	Frequency (MHz)	Factor (dB)	Reading (dBuV)	Level (dBuV/m)	Limit (dBuV/m)	Margin (dB)	Detector	Height (cm)	Azimuth (deg)	P/F
1	5150.00	7.18	44.80	51.98	54.00	-2.02	Average	104	341	P
2	5150.00	7.18	57.79	64.97	74.00	-9.03	Peak	104	341	P
3	5190.00	7.28	89.68	96.96	200.00	-103.04	Average	104	341	P
4	5190.00	7.28	102.20	109.48	200.00	-90.52	Peak	104	341	P
5	10380.00	15.19	43.85	59.04	68.20	-9.16	Peak	100	154	P
6	15570.00	19.60	29.78	49.38	54.00	-4.62	Average	100	229	P
7	15570.00	19.60	43.29	62.89	74.00	-11.11	Peak	100	229	P

Note: Level=Reading+Factor  
Margin=Level-Limit  
Factor=Antenna Factor + cable loss - Amplifier Factor



Test Mode : 2TX 11be EHT40 CH38 NSS1 MCS0  
Voltage : From Adapter(AC120V/60Hz)  
Pol : Horizontal

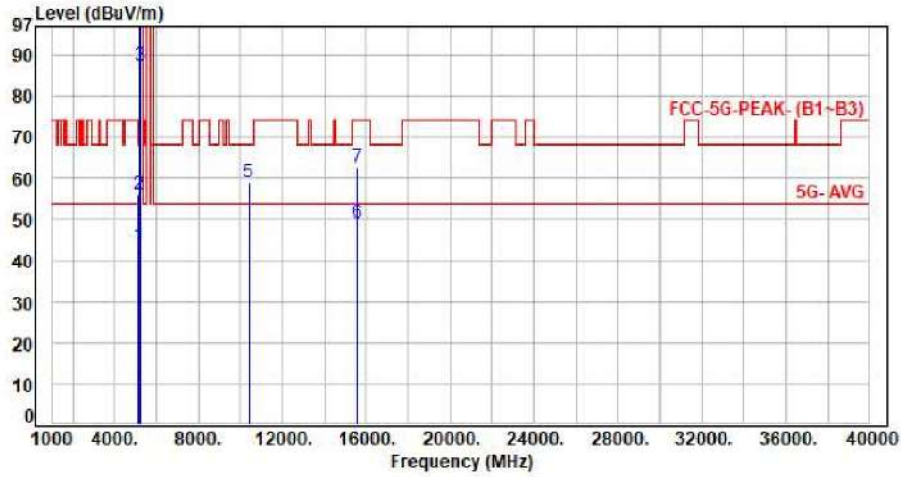

No.	Frequency (MHz)	Factor (dB)	Reading (dBuV)	Level (dBuV/m)	Limit (dBuV/m)	Margin (dB)	Detector	Height (cm)	Azimuth (deg)	P/F
1	5150.00	7.18	36.37	43.55	54.00	-10.45	Average	127	32	P
2	5150.00	7.18	48.83	56.01	74.00	-17.99	Peak	127	32	P
3	5190.00	7.28	80.08	87.36	200.00	-112.64	Average	127	32	P
4	5190.00	7.28	92.40	99.68	200.00	-100.32	Peak	127	32	P
5	10380.00	15.19	43.94	59.13	68.20	-9.07	Peak	100	28	P
6	15570.00	19.60	29.48	49.08	54.00	-4.92	Average	100	144	P
7	15570.00	19.60	43.17	62.77	74.00	-11.23	Peak	100	144	P

Note: Level=Reading+Factor  
Margin=Level-Limit  
Factor=Antenna Factor + cable loss - Amplifier Factor



Test Mode : 2TX 11be EHT40 CH46 NSS1 MCS0  
Voltage : From Adapter(AC120V/60Hz)  
Pol : Vertical

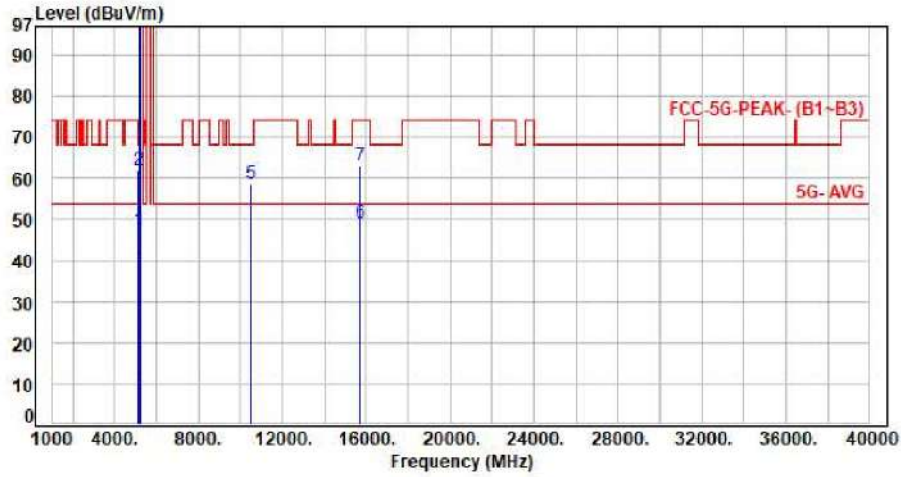

No.	Frequency (MHz)	Factor (dB)	Reading (dBuV)	Level (dBuV/m)	Limit (dBuV/m)	Margin (dB)	Detector	Height (cm)	Azimuth (deg)	P/F
1	5150.00	7.18	40.16	47.34	54.00	-6.66	Average	103	236	P
2	5150.00	7.18	54.93	62.11	74.00	-11.89	Peak	103	236	P
3	5230.00	7.31	91.59	98.90	200.00	-101.10	Average	103	236	P
4	5230.00	7.31	104.49	111.80	200.00	-88.20	Peak	103	236	P
5	10460.00	15.32	43.26	58.58	68.20	-9.62	Peak	100	158	P
6	15690.00	19.60	29.58	49.18	54.00	-4.82	Average	100	225	P
7	15690.00	19.60	43.65	63.25	74.00	-10.75	Peak	100	225	P

Note: Level=Reading+Factor  
Margin=Level-Limit  
Factor=Antenna Factor + cable loss - Amplifier Factor



Test Mode : 2TX 11be EHT40 CH46 NSS1 MCS0  
Voltage : From Adapter(AC120V/60Hz)  
Pol : Horizontal

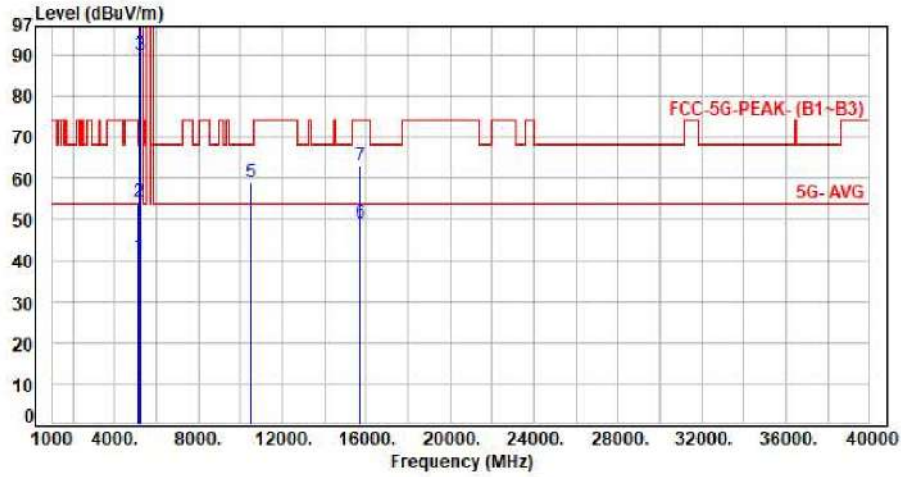

No.	Frequency (MHz)	Factor (dB)	Reading (dBuV)	Level (dBuV/m)	Limit (dBuV/m)	Margin (dB)	Detector	Height (cm)	Azimuth (deg)	P/F
1	5150.00	7.18	33.77	40.95	54.00	-13.05	Average	132	33	P
2	5150.00	7.18	46.94	54.12	74.00	-19.88	Peak	132	33	P
3	5230.00	7.31	82.81	90.12	200.00	-109.88	Average	132	33	P
4	5230.00	7.31	95.71	103.02	200.00	-96.98	Peak	132	33	P
5	10460.00	15.32	43.68	59.00	68.20	-9.20	Peak	100	25	P
6	15690.00	19.60	29.59	49.19	54.00	-4.81	Average	100	143	P
7	15690.00	19.60	43.37	62.97	74.00	-11.03	Peak	100	143	P

Note: Level=Reading+Factor  
Margin=Level-Limit  
Factor=Antenna Factor + cable loss - Amplifier Factor



Test Mode : 2TX 11be EHT80 CH42 NSS1 MCS0  
Voltage : From Adapter(AC120V/60Hz)  
Pol : Vertical

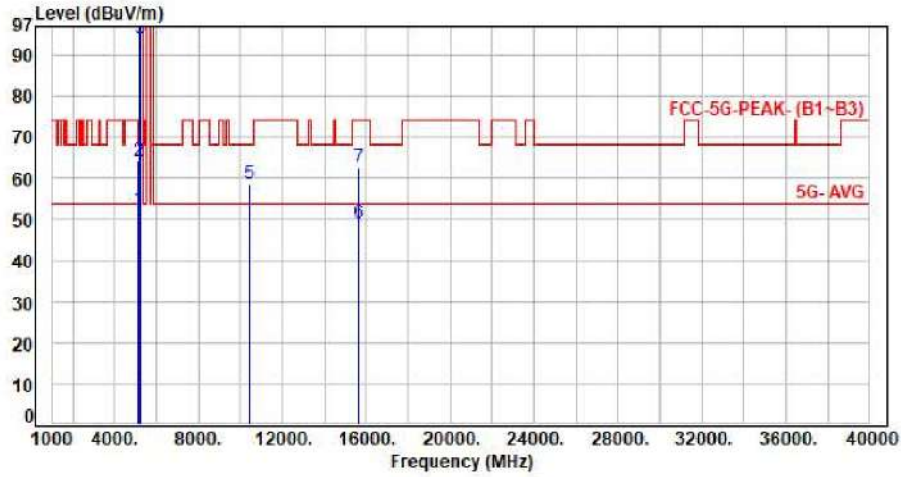

No.	Frequency (MHz)	Factor (dB)	Reading (dBuV)	Level (dBuV/m)	Limit (dBuV/m)	Margin (dB)	Detector	Height (cm)	Azimuth (deg)	P/F
1	5150.00	7.18	45.13	52.31	54.00	-1.69	Average	129	337	P
2	5150.00	7.18	56.86	64.04	74.00	-9.96	Peak	129	337	P
3	5210.00	7.31	86.75	94.06	200.00	-105.94	Average	129	337	P
4	5210.00	7.31	99.53	106.84	200.00	-93.16	Peak	129	337	P
5	10420.00	15.19	43.47	58.66	68.20	-9.54	Peak	100	154	P
6	15630.00	19.44	29.57	49.01	54.00	-4.99	Average	100	227	P
7	15630.00	19.44	43.43	62.87	74.00	-11.13	Peak	100	227	P

Note: Level=Reading+Factor  
Margin=Level-Limit  
Factor=Antenna Factor + cable loss - Amplifier Factor



Test Mode : 2TX 11be EHTB0 CH42 NSS1 MCS0  
Voltage : From Adapter(AC120V/60Hz)  
Pol : Horizontal

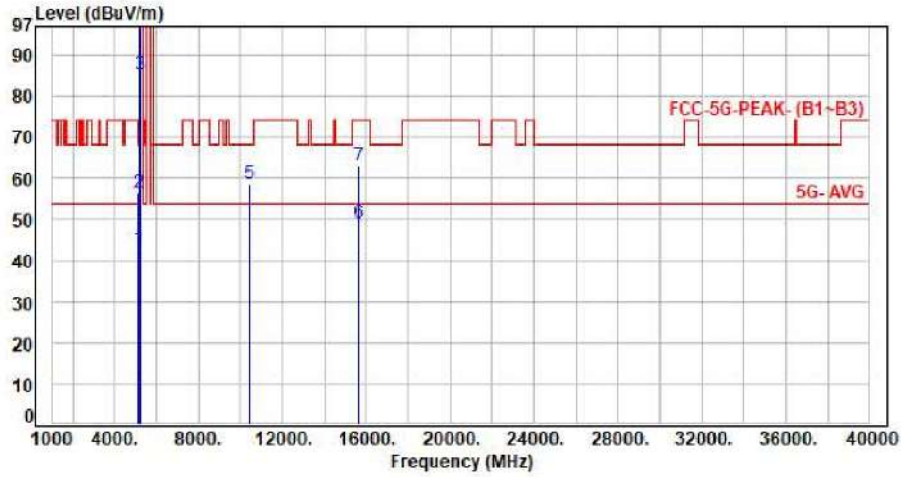

No.	Frequency (MHz)	Factor (dB)	Reading (dBuV)	Level (dBuV/m)	Limit (dBuV/m)	Margin (dB)	Detector	Height (cm)	Azimuth (deg)	P/F
1	5150.00	7.18	35.77	42.95	54.00	-11.05	Average	165	33	P
2	5150.00	7.18	49.30	56.48	74.00	-17.52	Peak	165	33	P
3	5210.00	7.31	78.06	85.37	200.00	-114.63	Average	165	33	P
4	5210.00	7.31	89.42	96.73	200.00	-103.27	Peak	165	33	P
5	10420.00	15.19	43.42	58.61	68.20	-9.59	Peak	100	29	P
6	15630.00	19.44	29.59	49.03	54.00	-4.97	Average	100	147	P
7	15630.00	19.44	43.59	63.03	74.00	-10.97	Peak	100	147	P

Note: Level=Reading+Factor  
Margin=Level-Limit  
Factor=Antenna Factor + cable loss - Amplifier Factor



Test Mode : 2TX 11a CH52 6Mbps  
Voltage : From Adapter(AC120V/60Hz)  
Pol : Vertical

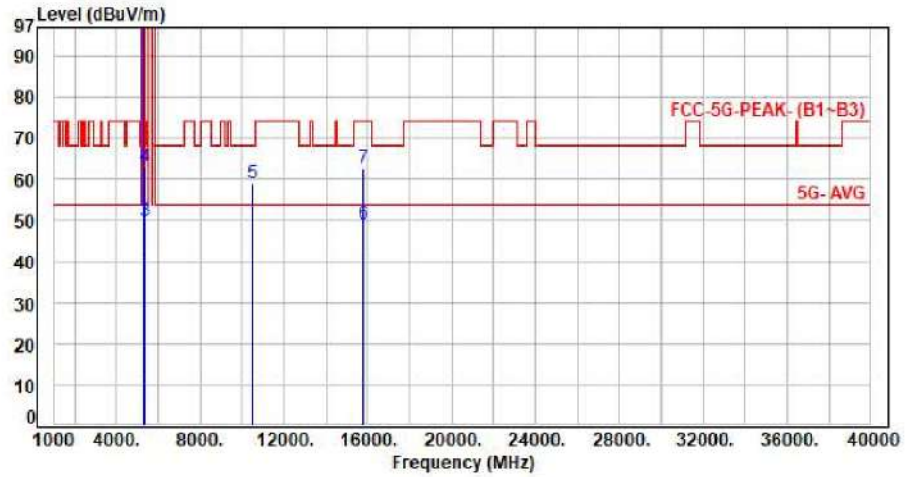

No.	Frequency (MHz)	Factor (dB)	Reading (dBuV)	Level (dBuV/m)	Limit (dBuV/m)	Margin (dB)	Detector	Height (cm)	Azimuth (deg)	P/F
1	5260.00	7.37	100.47	107.84	200.00	-92.16	Average	125	338	P
2	5260.00	7.37	110.43	117.80	200.00	-82.20	Peak	125	338	P
3	5350.00	7.67	41.97	49.64	54.00	-4.36	Average	125	338	P
4	5350.00	7.67	55.40	63.07	74.00	-10.93	Peak	125	338	P
5	10520.00	15.59	43.55	59.14	68.20	-9.06	Peak	100	157	P
6	15780.00	19.34	29.68	49.02	54.00	-4.98	Average	100	224	P
7	15780.00	19.34	43.24	62.58	74.00	-11.42	Peak	100	224	P

Note: Level=Reading+Factor  
Margin=Level-Limit  
Factor=Antenna Factor + cable loss - Amplifier Factor



Test Mode : 2TX 11a CH52 6Mbps  
Voltage : From Adapter(AC120V/60Hz)  
Pol : Horizontal

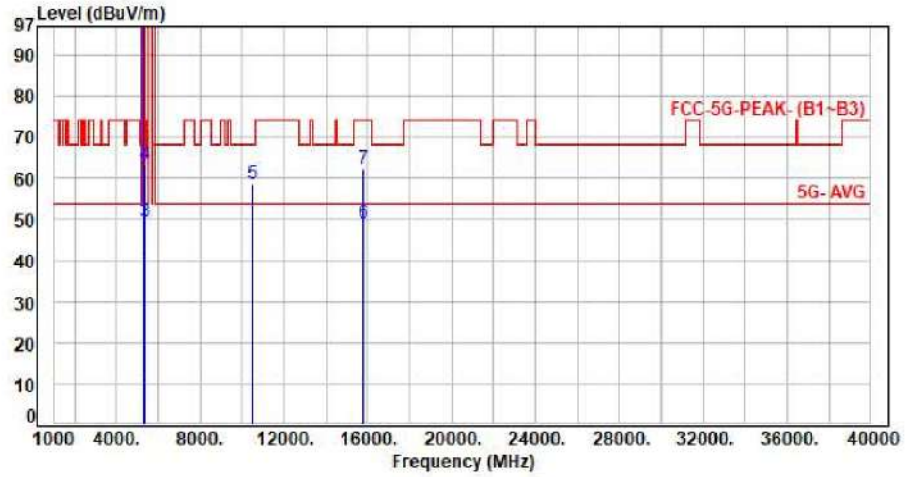

No.	Frequency (MHz)	Factor (dB)	Reading (dBuV)	Level (dBuV/m)	Limit (dBuV/m)	Margin (dB)	Detector	Height (cm)	Azimuth (deg)	P/F
1	5260.00	7.37	90.18	97.55	200.00	-102.45	Average	148	33	P
2	5260.00	7.37	100.32	107.69	200.00	-92.31	Peak	148	33	P
3	5350.00	7.67	41.80	49.47	54.00	-4.53	Average	148	33	P
4	5350.00	7.67	55.68	63.35	74.00	-10.65	Peak	148	33	P
5	10520.00	15.59	43.19	58.78	68.20	-9.42	Peak	100	29	P
6	15780.00	19.34	29.69	49.03	54.00	-4.97	Average	100	143	P
7	15780.00	19.34	42.84	62.18	74.00	-11.82	Peak	100	143	P

Note: Level=Reading+Factor  
Margin=Level-Limit  
Factor=Antenna Factor + cable loss - Amplifier Factor



Test Mode : 2TX 11a CH60 6Mbps  
Voltage : From Adapter(AC120V/60Hz)  
Pol : Vertical

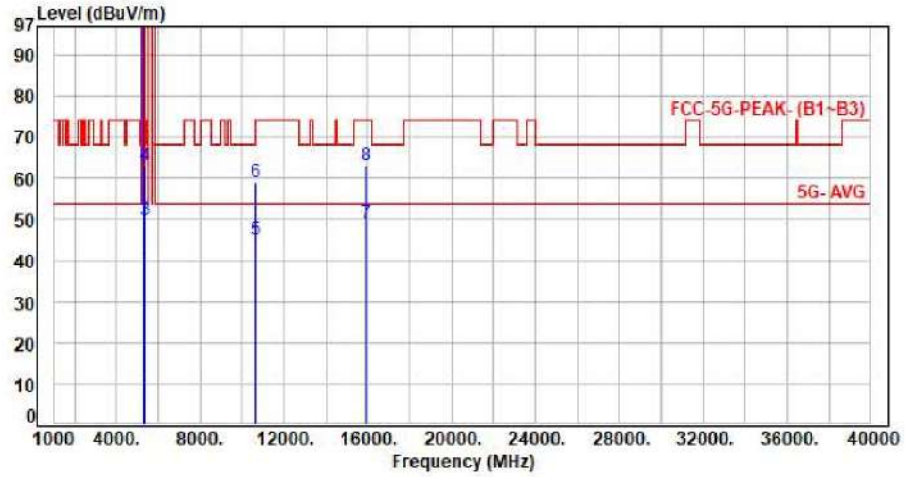

No.	Frequency (MHz)	Factor (dB)	Reading (dBuV)	Level (dBuV/m)	Limit (dBuV/m)	Margin (dB)	Detector	Height (cm)	Azimuth (deg)	P/F
1	5300.00	7.55	100.19	107.74	200.00	-92.26	Average	123	340	P
2	5300.00	7.55	110.15	117.70	200.00	-82.30	Peak	123	340	P
3	5350.00	7.67	42.09	49.76	54.00	-4.24	Average	123	340	P
4	5350.00	7.67	55.33	63.00	74.00	-11.00	Peak	123	340	P
5	10600.00	15.69	29.32	45.01	54.00	-8.99	Average	100	154	P
6	10600.00	15.69	43.16	58.85	74.00	-15.15	Peak	100	154	P
7	15900.00	19.12	29.85	48.97	54.00	-5.03	Average	100	226	P
8	15900.00	19.12	43.85	62.97	74.00	-11.03	Peak	100	226	P

Note: Level=Reading+Factor  
Margin=Level-Limit  
Factor=Antenna Factor + cable loss - Amplifier Factor



Test Mode : 2TX 11a CH60 6Mbps  
Voltage : From Adapter(AC120V/60Hz)  
Pol : Horizontal

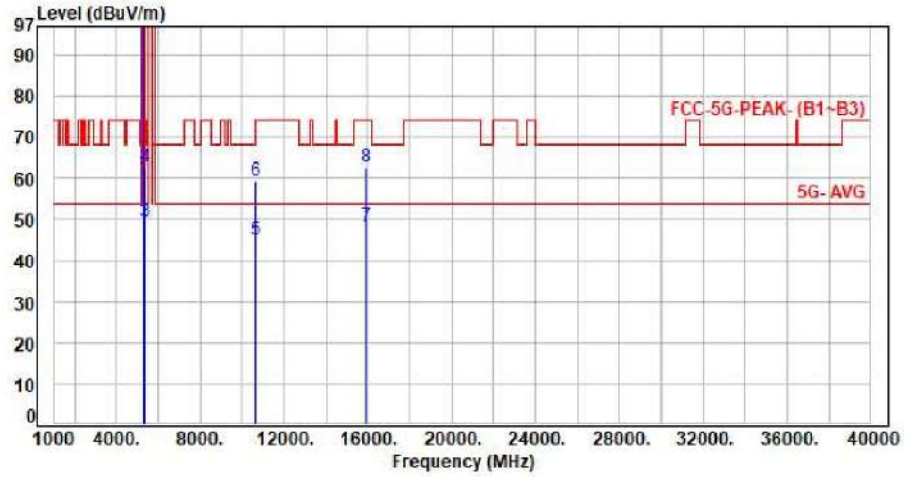

No.	Frequency (MHz)	Factor (dB)	Reading (dBuV)	Level (dBuV/m)	Limit (dBuV/m)	Margin (dB)	Detector	Height (cm)	Azimuth (deg)	P/F
1	5300.00	7.55	90.36	97.91	200.00	-102.09	Average	110	33	P
2	5300.00	7.55	100.35	107.90	200.00	-92.10	Peak	110	33	P
3	5350.00	7.67	41.86	49.53	54.00	-4.47	Average	110	33	P
4	5350.00	7.67	55.15	62.82	74.00	-11.18	Peak	110	33	P
5	10600.00	15.69	29.29	44.98	54.00	-9.02	Average	100	28	P
6	10600.00	15.69	43.59	59.28	74.00	-14.72	Peak	100	28	P
7	15900.00	19.12	29.15	48.27	54.00	-5.73	Average	100	148	P
8	15900.00	19.12	43.44	62.56	74.00	-11.44	Peak	100	148	P

Note: Level=Reading+Factor  
Margin=Level-Limit  
Factor=Antenna Factor + cable loss - Amplifier Factor



Test Mode : 2TX 11a CH64 6Mbps  
 Voltage : From Adapter(AC120V/60Hz)  
 Pol : Vertical

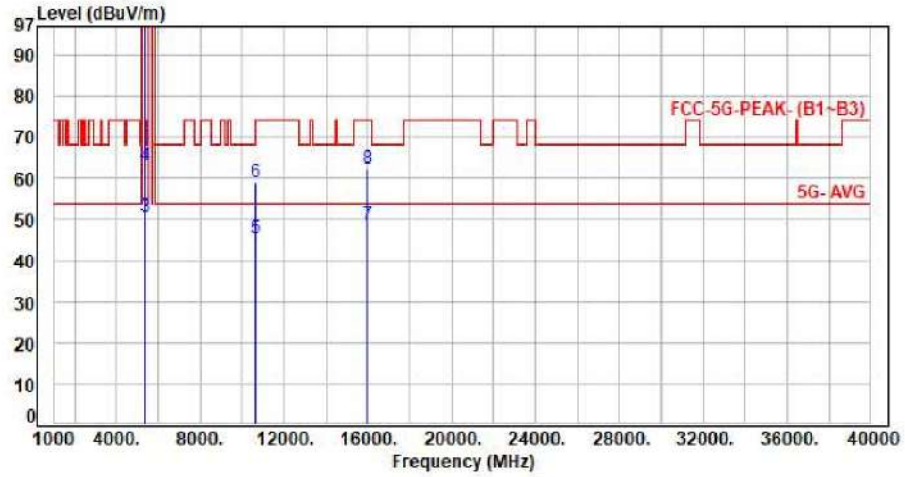

No.	Frequency (MHz)	Factor (dB)	Reading (dBuV)	Level (dBuV/m)	Limit (dBuV/m)	Margin (dB)	Detector	Height (cm)	Azimuth (deg)	P/F
1	5320.00	7.60	99.82	107.42	200.00	-92.58	Average	115	340	P
2	5320.00	7.60	109.88	117.48	200.00	-82.52	Peak	115	340	P
3	5350.00	7.67	42.98	50.65	54.00	-3.35	Average	115	340	P
4	5350.00	7.67	55.56	63.23	74.00	-10.77	Peak	115	340	P
5	10640.00	15.73	29.57	45.30	54.00	-8.70	Average	100	157	P
6	10640.00	15.73	43.16	58.89	74.00	-15.11	Peak	100	157	P
7	15960.00	19.05	29.63	48.68	54.00	-5.32	Average	100	229	P
8	15960.00	19.05	43.27	62.32	74.00	-11.68	Peak	100	229	P

Note: Level=Reading+Factor  
 Margin=Level-Limit  
 Factor=Antenna Factor + cable loss - Amplifier Factor



Test Mode : 2TX 11a CH64 6Mbps  
Voltage : From Adapter(AC120V/60Hz)  
Pol : Horizontal

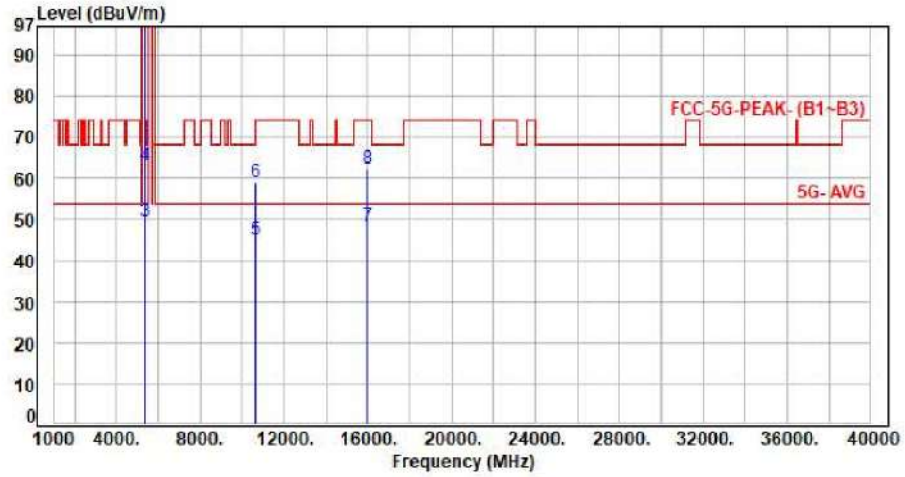

No.	Frequency (MHz)	Factor (dB)	Reading (dBuV)	Level (dBuV/m)	Limit (dBuV/m)	Margin (dB)	Detector	Height (cm)	Azimuth (deg)	P/F
1	5320.00	7.60	90.61	98.21	200.00	-101.79	Average	137	36	P
2	5320.00	7.60	100.58	108.18	200.00	-91.82	Peak	137	36	P
3	5350.00	7.67	41.85	49.52	54.00	-4.48	Average	137	36	P
4	5350.00	7.67	55.31	62.98	74.00	-11.02	Peak	137	36	P
5	10640.00	15.73	29.34	45.07	54.00	-8.93	Average	100	27	P
6	10640.00	15.73	43.22	58.95	74.00	-15.05	Peak	100	27	P
7	15960.00	19.05	29.38	48.43	54.00	-5.57	Average	100	147	P
8	15960.00	19.05	43.43	62.48	74.00	-11.52	Peak	100	147	P

Note: Level=Reading+Factor  
Margin=Level-Limit  
Factor=Antenna Factor + cable loss - Amplifier Factor



Test Mode : 2TX 11be EHT20 CH52 NSS1 MCS0  
Voltage : From Adapter(AC120V/60Hz)  
Pol : Vertical

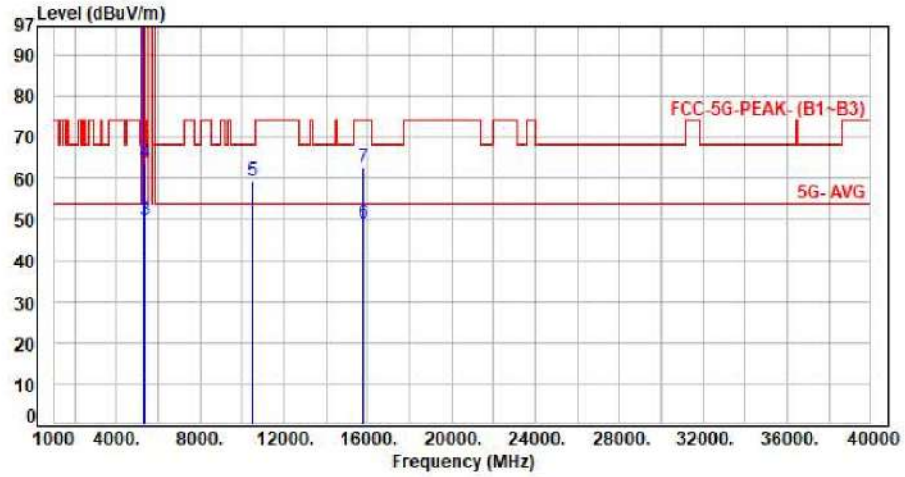

No.	Frequency (MHz)	Factor (dB)	Reading (dBuV)	Level (dBuV/m)	Limit (dBuV/m)	Margin (dB)	Detector	Height (cm)	Azimuth (deg)	P/F
1	5260.00	7.37	100.80	108.17	200.00	-91.83	Average	125	340	P
2	5260.00	7.37	113.30	120.67	200.00	-79.33	Peak	125	340	P
3	5350.00	7.67	42.17	49.84	54.00	-4.16	Average	125	340	P
4	5350.00	7.67	55.99	63.66	74.00	-10.34	Peak	125	340	P
5	10520.00	15.59	43.66	59.25	68.20	-8.95	Peak	100	153	P
6	15780.00	19.34	29.57	48.91	54.00	-5.09	Average	100	224	P
7	15780.00	19.34	43.45	62.80	74.00	-11.20	Peak	100	224	P

Note: Level=Reading+Factor  
Margin=Level-Limit  
Factor=Antenna Factor + cable loss - Amplifier Factor



Test Mode : 2TX 11be EHT20 CH52 NSS1 MCS0  
Voltage : From Adapter(AC120V/60Hz)  
Pol : Horizontal

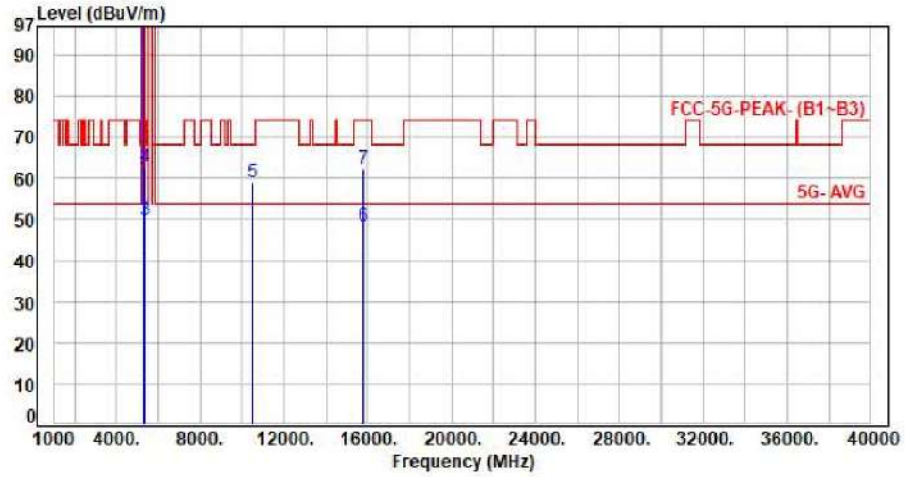

No.	Frequency (MHz)	Factor (dB)	Reading (dBuV)	Level (dBuV/m)	Limit (dBuV/m)	Margin (dB)	Detector	Height (cm)	Azimuth (deg)	P/F
1	5260.00	7.37	89.79	97.16	200.00	-102.84	Average	150	36	P
2	5260.00	7.37	101.78	109.15	200.00	-90.85	Peak	150	36	P
3	5350.00	7.67	41.99	49.66	54.00	-4.34	Average	150	36	P
4	5350.00	7.67	55.09	62.76	74.00	-11.24	Peak	150	36	P
5	10520.00	15.59	43.36	58.95	68.20	-9.25	Peak	100	27	P
6	15780.00	19.34	29.06	48.40	54.00	-5.60	Average	100	146	P
7	15780.00	19.34	43.11	62.45	74.00	-11.55	Peak	100	146	P

Note: Level=Reading+Factor  
Margin=Level-Limit  
Factor=Antenna Factor + cable loss - Amplifier Factor



Test Mode : 2TX 11be EHT20 CH60 NSS1 MCS0  
Voltage : From Adapter(AC120V/60Hz)  
Pol : Vertical

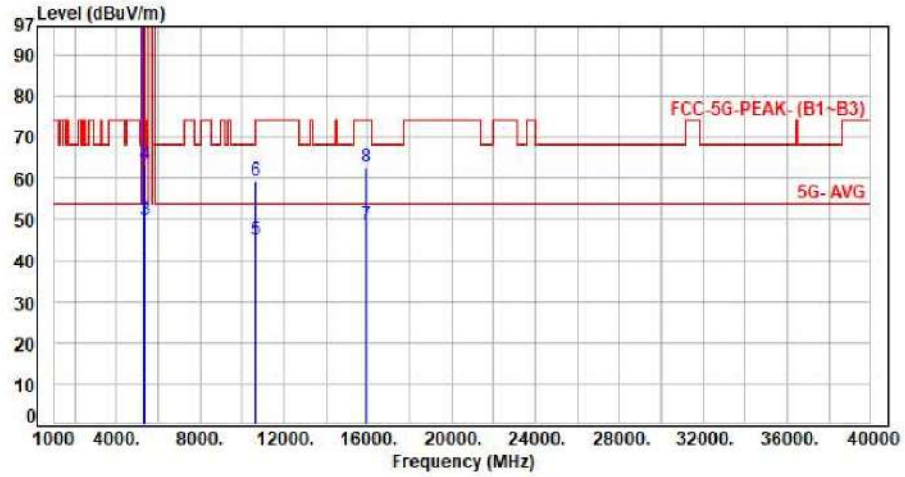

No.	Frequency (MHz)	Factor (dB)	Reading (dBuV)	Level (dBuV/m)	Limit (dBuV/m)	Margin (dB)	Detector	Height (cm)	Azimuth (deg)	P/F
1	5300.00	7.55	101.08	108.63	200.00	-91.37	Average	122	340	P
2	5300.00	7.55	113.11	120.66	200.00	-79.34	Peak	122	340	P
3	5350.00	7.67	42.29	49.96	54.00	-4.04	Average	122	340	P
4	5350.00	7.67	55.82	63.49	74.00	-10.51	Peak	122	340	P
5	10600.00	15.69	29.27	44.96	54.00	-9.04	Average	100	157	P
6	10600.00	15.69	43.53	59.22	74.00	-14.78	Peak	100	157	P
7	15900.00	19.12	29.60	48.72	54.00	-5.28	Average	100	228	P
8	15900.00	19.12	43.56	62.68	74.00	-11.32	Peak	100	228	P

Note: Level=Reading+Factor  
Margin=Level-Limit  
Factor=Antenna Factor + cable loss - Amplifier Factor



Test Mode : 2TX 11be EHT20 CH60 NSS1 MCS0  
 Voltage : From Adapter(AC120V/60Hz)  
 Pol : Horizontal

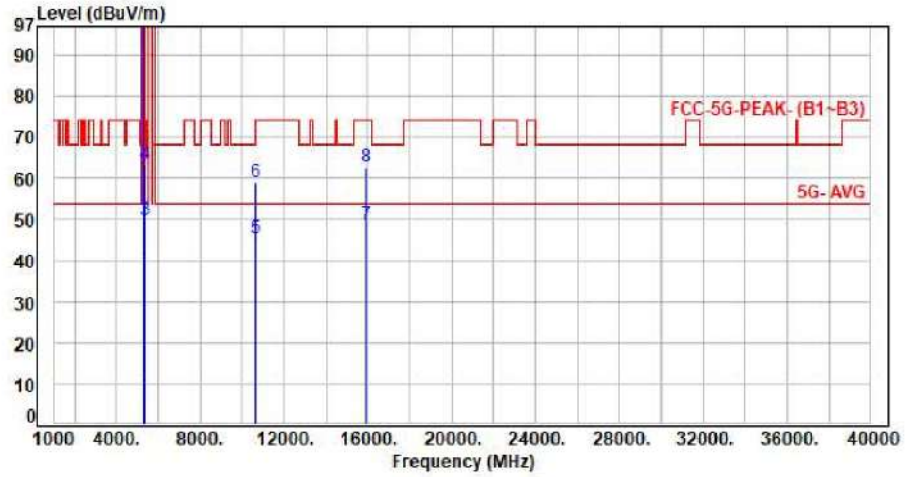

No.	Frequency (MHz)	Factor (dB)	Reading (dBuV)	Level (dBuV/m)	Limit (dBuV/m)	Margin (dB)	Detector	Height (cm)	Azimuth (deg)	P/F
1	5300.00	7.55	90.30	97.85	200.00	-102.15	Average	111	35	P
2	5300.00	7.55	102.86	110.41	200.00	-89.59	Peak	111	35	P
3	5350.00	7.67	41.94	49.61	54.00	-4.39	Average	111	35	P
4	5350.00	7.67	55.62	63.29	74.00	-10.71	Peak	111	35	P
5	10600.00	15.69	29.58	45.27	54.00	-8.73	Average	100	29	P
6	10600.00	15.69	43.46	59.15	74.00	-14.85	Peak	100	29	P
7	15900.00	19.12	29.70	48.82	54.00	-5.18	Average	100	148	P
8	15900.00	19.12	43.50	62.62	74.00	-11.38	Peak	100	148	P

Note: Level=Reading+Factor  
 Margin=Level-Limit  
 Factor=Antenna Factor + cable loss - Amplifier Factor



Test Mode : 2TX 11be EHT20 CH64 NSS1 MCS0  
Voltage : From Adapter(AC120V/60Hz)  
Pol : Vertical

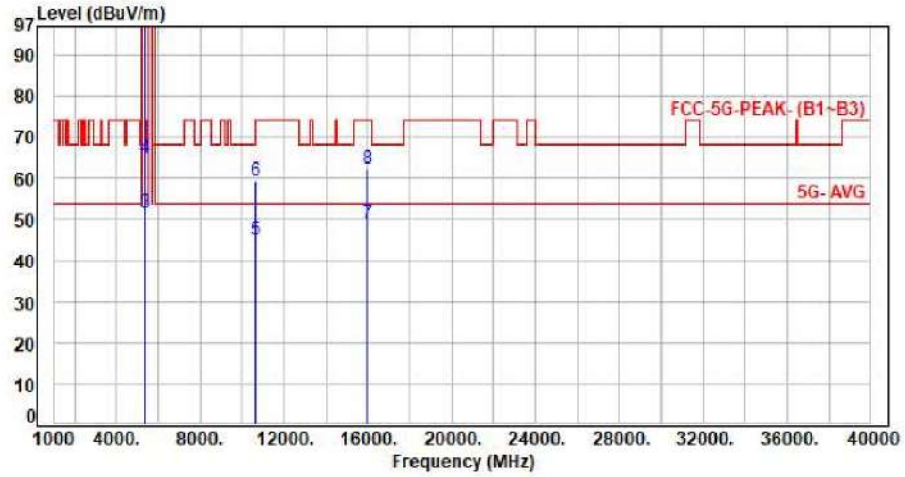

No.	Frequency (MHz)	Factor (dB)	Reading (dBuV)	Level (dBuV/m)	Limit (dBuV/m)	Margin (dB)	Detector	Height (cm)	Azimuth (deg)	P/F
1	5320.00	7.60	100.44	108.04	200.00	-91.96	Average	130	340	P
2	5320.00	7.60	112.73	120.33	200.00	-79.67	Peak	130	340	P
3	5350.00	7.67	43.84	51.51	54.00	-2.49	Average	130	340	P
4	5350.00	7.67	57.16	64.83	74.00	-9.17	Peak	130	340	P
5	10640.00	15.73	29.24	44.97	54.00	-9.03	Average	100	153	P
6	10640.00	15.73	43.58	59.31	74.00	-14.69	Peak	100	153	P
7	15960.00	19.05	29.86	48.91	54.00	-5.09	Average	100	228	P
8	15960.00	19.05	43.46	62.51	74.00	-11.49	Peak	100	228	P

Note: Level=Reading+Factor  
Margin=Level-Limit  
Factor=Antenna Factor + cable loss - Amplifier Factor



Test Mode : 2TX 11be EHT20 CH64 NSS1 MCS0  
Voltage : From Adapter(AC120V/60Hz)  
Pol : Horizontal

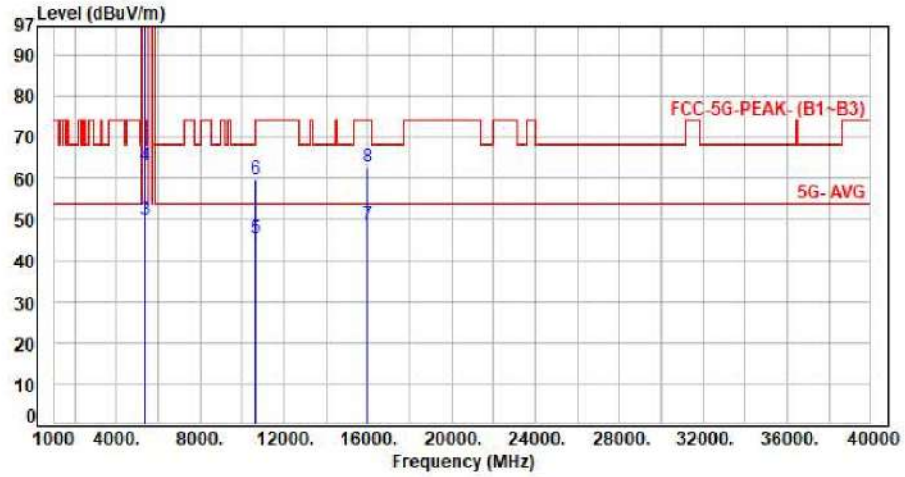

No.	Frequency (MHz)	Factor (dB)	Reading (dBuV)	Level (dBuV/m)	Limit (dBuV/m)	Margin (dB)	Detector	Height (cm)	Azimuth (deg)	P/F
1	5320.00	7.60	90.60	98.20	200.00	-101.80	Average	161	36	P
2	5320.00	7.60	102.86	110.46	200.00	-89.54	Peak	161	36	P
3	5350.00	7.67	42.04	49.71	54.00	-4.29	Average	161	36	P
4	5350.00	7.67	55.46	63.13	74.00	-10.87	Peak	161	36	P
5	10640.00	15.73	29.81	45.54	54.00	-8.46	Average	100	26	P
6	10640.00	15.73	44.14	59.87	74.00	-14.13	Peak	100	26	P
7	15960.00	19.05	29.68	48.73	54.00	-5.27	Average	100	143	P
8	15960.00	19.05	43.50	62.55	74.00	-11.45	Peak	100	143	P

Note: Level=Reading+Factor  
Margin=Level-Limit  
Factor=Antenna Factor + cable loss - Amplifier Factor



Test Mode : 2TX 11be EHT40 CH54 NSS1 MCS0  
Voltage : From Adapter(AC120V/60Hz)  
Pol : Vertical

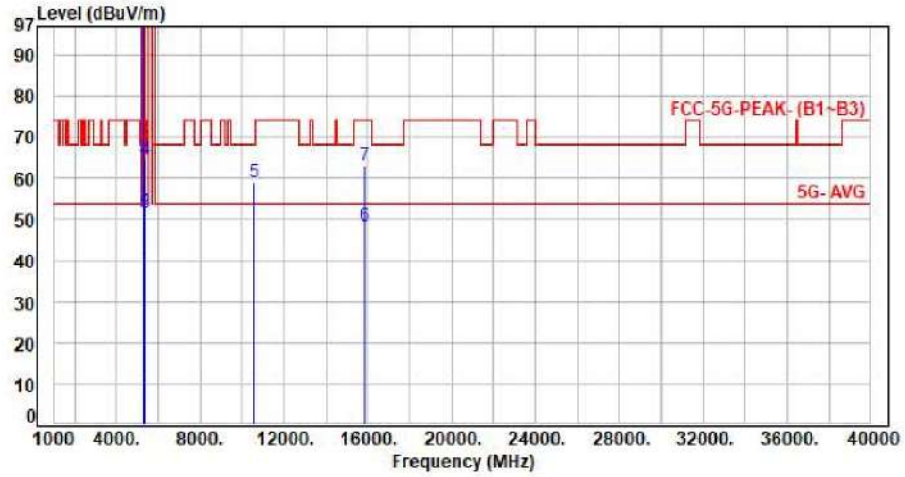

No.	Frequency (MHz)	Factor (dB)	Reading (dBuV)	Level (dBuV/m)	Limit (dBuV/m)	Margin (dB)	Detector	Height (cm)	Azimuth (deg)	P/F
1	5270.00	7.42	100.62	108.04	200.00	-91.96	Average	124	340	P
2	5270.00	7.42	113.36	120.78	200.00	-79.22	Peak	124	340	P
3	5350.00	7.67	44.14	51.81	54.00	-2.19	Average	124	340	P
4	5350.00	7.67	56.99	64.66	74.00	-9.34	Peak	124	340	P
5	10540.00	15.61	43.52	59.13	68.20	-9.07	Peak	100	158	P
6	15810.00	19.17	29.21	48.38	54.00	-5.62	Average	100	225	P
7	15810.00	19.17	43.98	63.15	74.00	-10.85	Peak	100	225	P

Note: Level=Reading+Factor  
Margin=Level-Limit  
Factor=Antenna Factor + cable loss - Amplifier Factor



Test Mode : 2TX 11be EHT40 CH54 NSS1 MCS0  
Voltage : From Adapter(AC120V/60Hz)  
Pol : Horizontal

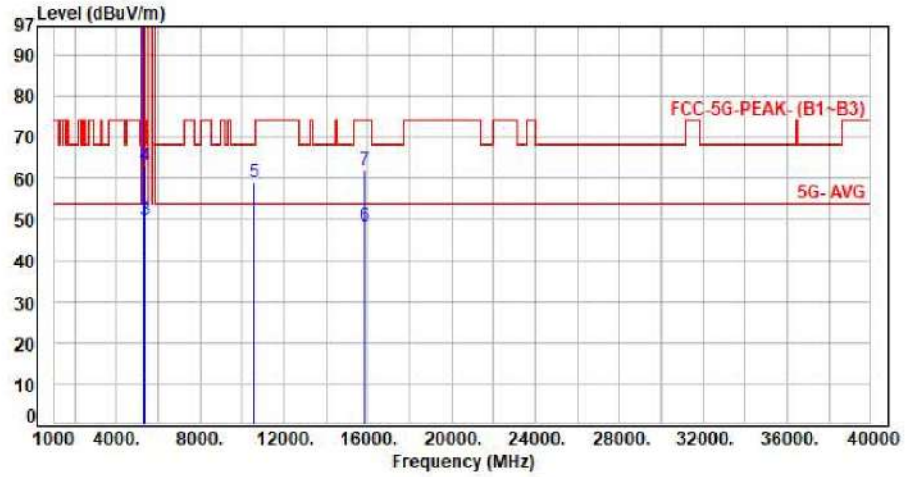

No.	Frequency (MHz)	Factor (dB)	Reading (dBuV)	Level (dBuV/m)	Limit (dBuV/m)	Margin (dB)	Detector	Height (cm)	Azimuth (deg)	P/F
1	5270.00	7.42	89.87	97.29	200.00	-102.71	Average	124	34	P
2	5270.00	7.42	104.02	111.44	200.00	-88.56	Peak	124	34	P
3	5350.00	7.67	42.14	49.81	54.00	-4.19	Average	124	34	P
4	5350.00	7.67	55.54	63.21	74.00	-10.79	Peak	124	34	P
5	10540.00	15.61	43.38	58.99	68.20	-9.21	Peak	100	27	P
6	15810.00	19.17	29.24	48.41	54.00	-5.59	Average	100	145	P
7	15810.00	19.17	42.93	62.10	74.00	-11.90	Peak	100	145	P

Note: Level=Reading+Factor  
Margin=Level-Limit  
Factor=Antenna Factor + cable loss - Amplifier Factor



Test Mode : 2TX 11be EHT40 CH62 NSS1 MCS0  
Voltage : From Adapter(AC120V/60Hz)  
Pol : Vertical

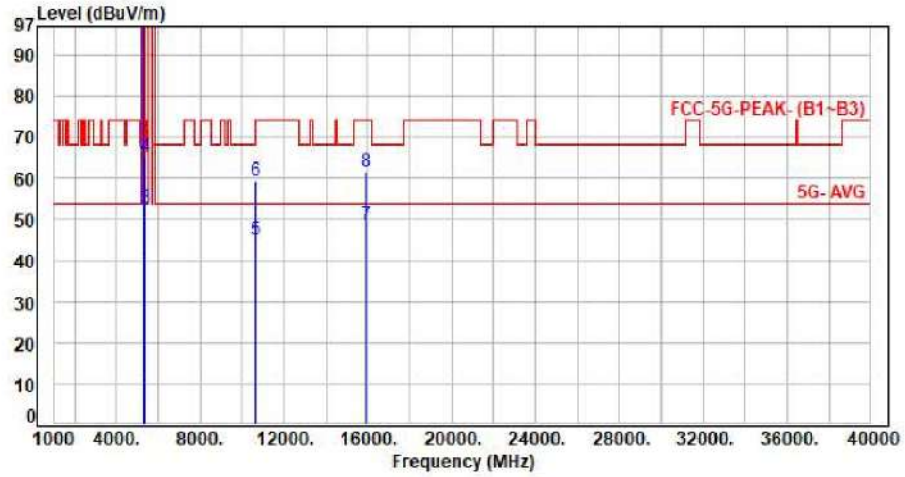

No.	Frequency (MHz)	Factor (dB)	Reading (dBuV)	Level (dBuV/m)	Limit (dBuV/m)	Margin (dB)	Detector	Height (cm)	Azimuth (deg)	P/F
1	5310.00	7.57	96.98	104.55	200.00	-95.45	Average	119	342	P
2	5310.00	7.57	108.63	116.20	200.00	-83.80	Peak	119	342	P
3	5350.00	7.67	44.92	52.59	54.00	-1.41	Average	119	342	P
4	5350.00	7.67	57.54	65.21	74.00	-8.79	Peak	119	342	P
5	10620.00	15.70	29.17	44.87	54.00	-9.13	Average	100	154	P
6	10620.00	15.70	43.57	59.27	74.00	-14.73	Peak	100	154	P
7	15930.00	19.08	29.46	48.54	54.00	-5.46	Average	100	226	P
8	15930.00	19.08	42.67	61.75	74.00	-12.25	Peak	100	226	P

Note: Level=Reading+Factor  
Margin=Level-Limit  
Factor=Antenna Factor + cable loss - Amplifier Factor



Test Mode : 2TX 11be EHT40 CH62 NSS1 MCS0  
 Voltage : From Adapter(AC120V/60Hz)  
 Pol : Horizontal

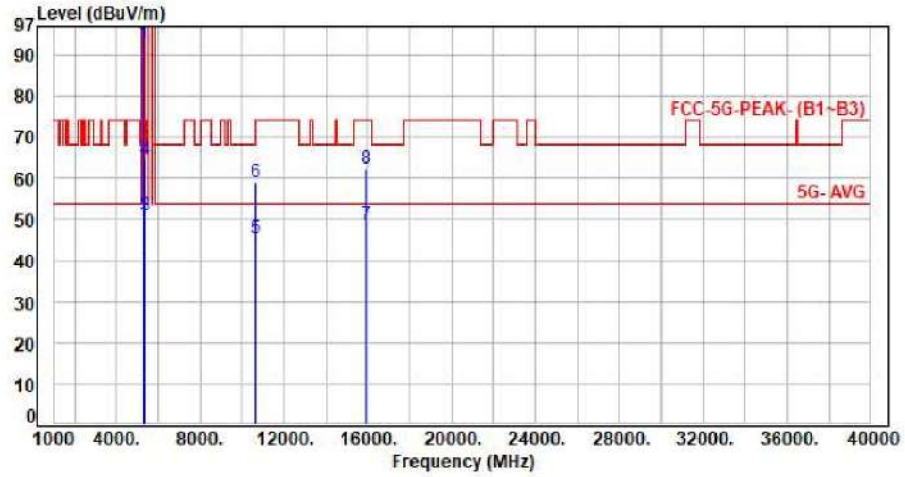

No.	Frequency (MHz)	Factor (dB)	Reading (dBuV)	Level (dBuV/m)	Limit (dBuV/m)	Margin (dB)	Detector	Height (cm)	Azimuth (deg)	P/F
1	5310.00	7.57	85.52	93.09	200.00	-106.91	Average	100	274	P
2	5310.00	7.57	97.85	105.42	200.00	-94.58	Peak	100	274	P
3	5350.00	7.67	43.26	50.93	54.00	-3.07	Average	100	274	P
4	5350.00	7.67	56.98	64.65	74.00	-9.35	Peak	100	274	P
5	10620.00	15.70	29.59	45.29	54.00	-8.71	Average	100	29	P
6	10620.00	15.70	43.47	59.17	74.00	-14.83	Peak	100	29	P
7	15930.00	19.08	29.47	48.55	54.00	-5.45	Average	100	145	P
8	15930.00	19.08	43.25	62.33	74.00	-11.67	Peak	100	145	P

Note: Level=Reading+Factor  
 Margin=Level-Limit  
 Factor=Antenna Factor + cable loss - Amplifier Factor



Test Mode : 2TX 11be EHT80 CH58 NSS1 MCS0  
 Voltage : From Adapter(AC120V/60Hz)  
 Pol : Vertical

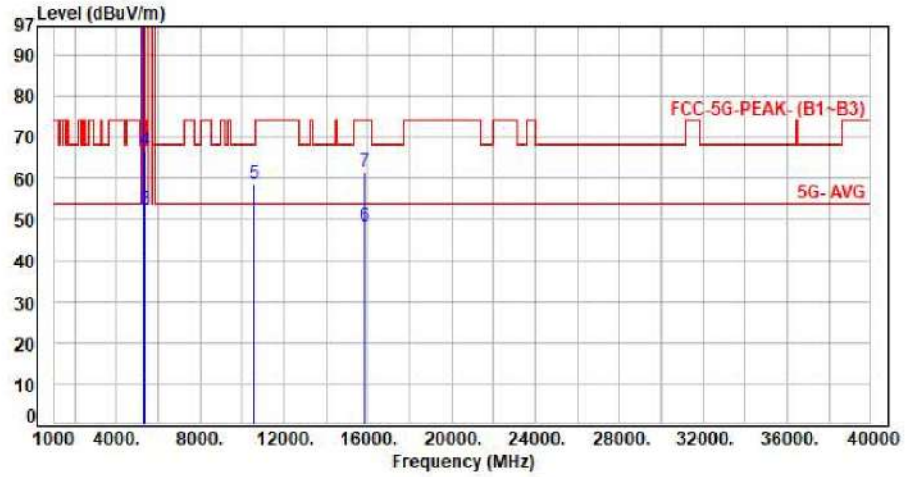

No.	Frequency (MHz)	Factor (dB)	Reading (dBuV)	Level (dBuV/m)	Limit (dBuV/m)	Margin (dB)	Detector	Height (cm)	Azimuth (deg)	P/F
1	5290.00	7.50	94.16	101.66	200.00	-98.34	Average	100	341	P
2	5290.00	7.50	106.68	114.18	200.00	-85.82	Peak	100	341	P
3	5350.00	7.67	44.80	52.47	54.00	-1.53	Average	100	341	P
4	5350.00	7.67	59.07	66.74	74.00	-7.26	Peak	100	341	P
5	10580.00	15.66	43.16	58.82	68.20	-9.38	Peak	100	155	P
6	15870.00	19.12	29.36	48.48	54.00	-5.52	Average	100	224	P
7	15870.00	19.12	42.63	61.75	74.00	-12.25	Peak	100	224	P

Note: Level=Reading+Factor  
 Margin=Level-Limit  
 Factor=Antenna Factor + cable loss - Amplifier Factor



Test Mode : 2TX 11be EHT80 CH58 NSS1 MCS0  
Voltage : From Adapter(AC120V/60Hz)  
Pol : Horizontal

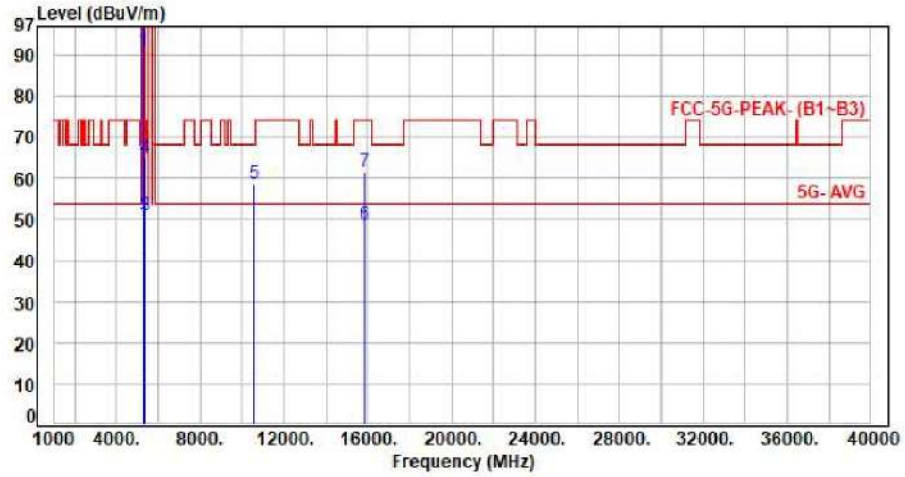

No.	Frequency (MHz)	Factor (dB)	Reading (dBuV)	Level (dBuV/m)	Limit (dBuV/m)	Margin (dB)	Detector	Height (cm)	Azimuth (deg)	P/F
1	5290.00	7.50	83.49	90.99	200.00	-109.01	Average	114	35	P
2	5290.00	7.50	94.90	102.40	200.00	-97.60	Peak	114	35	P
3	5350.00	7.67	43.20	50.87	54.00	-3.13	Average	114	35	P
4	5350.00	7.67	57.18	64.85	74.00	-9.15	Peak	114	35	P
5	10580.00	15.66	42.89	58.55	68.20	-9.65	Peak	100	25	P
6	15870.00	19.12	29.46	48.58	54.00	-5.42	Average	100	149	P
7	15870.00	19.12	42.50	61.62	74.00	-12.38	Peak	100	149	P

Note: Level=Reading+Factor  
Margin=Level-Limit  
Factor=Antenna Factor + cable loss - Amplifier Factor



Test Mode : 2TX 11a CH100 6Mbps  
Voltage : From Adapter(AC120V/60Hz)  
Pol : Vertical

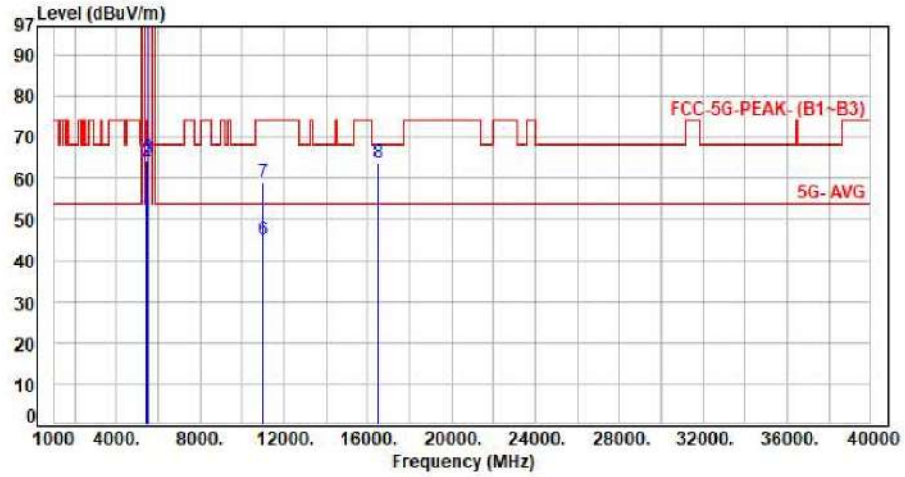

No.	Frequency (MHz)	Factor (dB)	Reading (dBuV)	Level (dBuV/m)	Limit (dBuV/m)	Margin (dB)	Detector	Height (cm)	Azimuth (deg)	P/F
1	5460.00	7.72	43.35	51.07	54.00	-2.93	Average	100	53	P
2	5460.00	7.72	56.53	64.25	74.00	-9.75	Peak	100	53	P
3	5470.00	7.72	57.32	65.04	68.20	-3.16	Peak	100	53	P
4	5500.00	7.73	99.49	107.22	200.00	-92.78	Average	100	53	P
5	5500.00	7.73	109.53	117.26	200.00	-82.74	Peak	100	53	P
6	11000.00	15.79	29.26	45.05	54.00	-8.95	Average	100	154	P
7	11000.00	15.79	43.13	58.92	74.00	-15.08	Peak	100	154	P
8	16500.00	20.93	42.85	63.78	68.20	-4.42	Peak	100	229	P

Note: Level=Reading+Factor  
Margin=Level-Limit  
Factor=Antenna Factor + cable loss - Amplifier Factor



Test Mode : 2TX 11a CH100 6Mbps  
Voltage : From Adapter(AC120V/60Hz)  
Pol : Horizontal

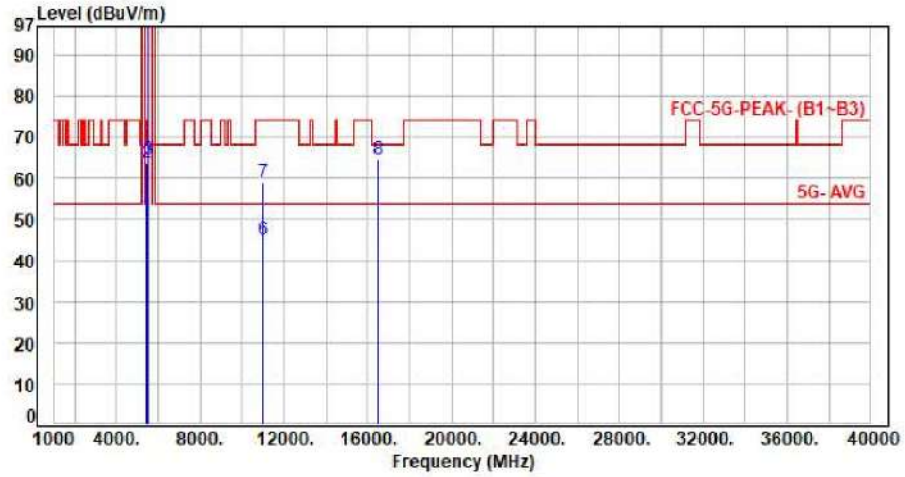

No.	Frequency (MHz)	Factor (dB)	Reading (dBuV)	Level (dBuV/m)	Limit (dBuV/m)	Margin (dB)	Detector	Height (cm)	Azimuth (deg)	P/F
1	5460.00	7.72	43.15	50.87	54.00	-3.13	Average	123	47	P
2	5460.00	7.72	56.08	63.80	74.00	-10.20	Peak	123	47	P
3	5470.00	7.72	56.68	64.40	68.20	-3.80	Peak	123	47	P
4	5500.00	7.73	88.82	96.55	200.00	-103.45	Average	123	47	P
5	5500.00	7.73	98.58	106.31	200.00	-93.69	Peak	123	47	P
6	11000.00	15.79	29.33	45.12	54.00	-8.88	Average	100	26	P
7	11000.00	15.79	43.10	58.89	74.00	-15.11	Peak	100	26	P
8	16500.00	20.93	43.63	64.56	68.20	-3.64	Peak	100	147	P

Note: Level=Reading+Factor  
Margin=Level-Limit  
Factor=Antenna Factor + cable loss - Amplifier Factor



Test Mode : 2TX 11a CH120 6Mbps  
Voltage : From Adapter(AC120V/60Hz)  
Pol : Vertical

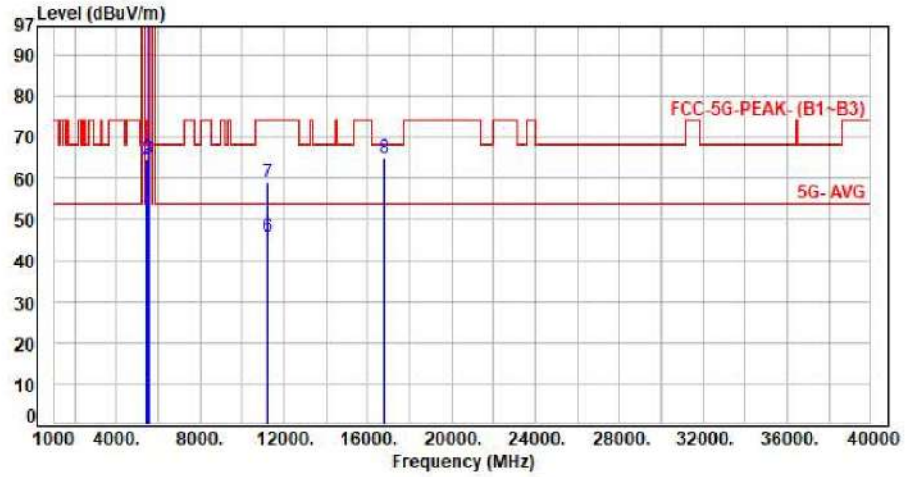

No.	Frequency (MHz)	Factor (dB)	Reading (dBuV)	Level (dBuV/m)	Limit (dBuV/m)	Margin (dB)	Detector	Height (cm)	Azimuth (deg)	P/F
1	5460.00	7.72	43.27	50.99	54.00	-3.01	Average	113	51	P
2	5460.00	7.72	56.64	64.36	74.00	-9.64	Peak	113	51	P
3	5470.00	7.72	57.33	65.05	68.20	-3.15	Peak	113	51	P
4	5600.00	7.47	99.30	106.77	200.00	-93.23	Average	113	51	P
5	5600.00	7.47	109.13	116.60	200.00	-83.40	Peak	113	51	P
6	11200.00	16.18	29.44	45.62	54.00	-8.38	Average	100	158	P
7	11200.00	16.18	42.94	59.12	74.00	-14.88	Peak	100	158	P
8	16800.00	22.69	42.28	64.97	68.20	-3.23	Peak	100	227	P

Note: Level=Reading+Factor  
Margin=Level-Limit  
Factor=Antenna Factor + cable loss - Amplifier Factor



Test Mode : 2TX 11a CH120 6Mbps  
 Voltage : From Adapter(AC120V/60Hz)  
 Pol : Horizontal

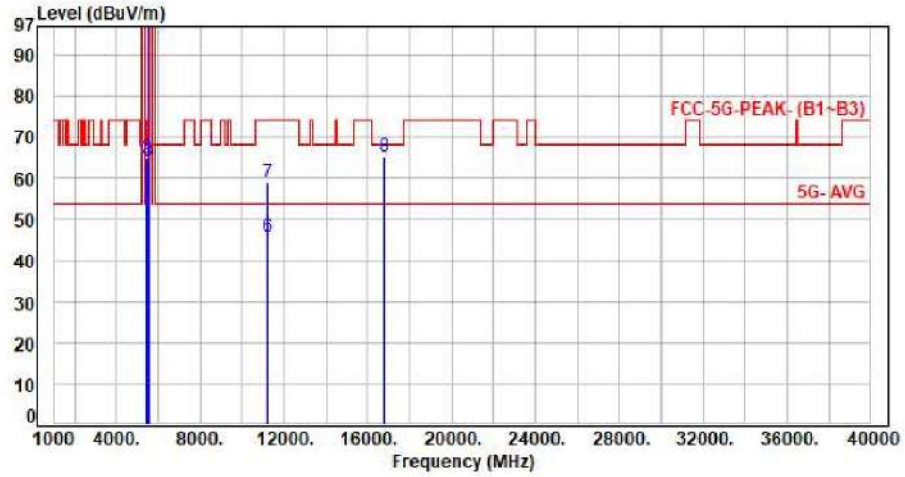

No.	Frequency (MHz)	Factor (dB)	Reading (dBuV)	Level (dBuV/m)	Limit (dBuV/m)	Margin (dB)	Detector	Height (cm)	Azimuth (deg)	P/F
1	5460.00	7.72	43.11	50.83	54.00	-3.17	Average	100	23	P
2	5460.00	7.72	57.26	64.98	74.00	-9.02	Peak	100	23	P
3	5470.00	7.72	56.55	64.27	68.20	-3.93	Peak	100	23	P
4	5600.00	7.47	88.66	96.13	200.00	-103.87	Average	100	23	P
5	5600.00	7.47	98.38	105.85	200.00	-94.15	Peak	100	23	P
6	11200.00	16.18	29.47	45.65	54.00	-8.35	Average	100	26	P
7	11200.00	16.18	42.83	59.01	74.00	-14.99	Peak	100	26	P
8	16800.00	22.69	42.47	65.16	68.20	-3.04	Peak	100	145	P

Note: Level=Reading+Factor  
 Margin=Level-Limit  
 Factor=Antenna Factor + cable loss - Amplifier Factor



Test Mode : 2TX 11a CH140 6Mbps  
Voltage : From Adapter(AC120V/60Hz)  
Pol : Vertical

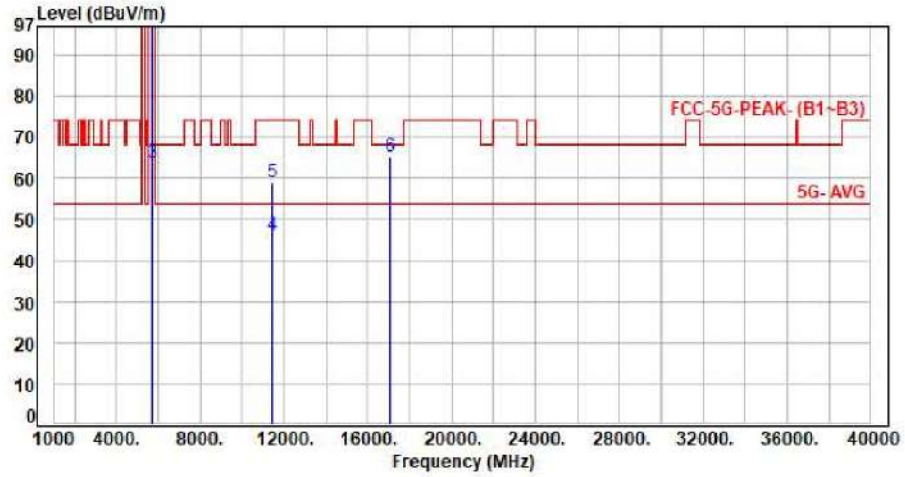

No.	Frequency (MHz)	Factor (dB)	Reading (dBuV)	Level (dBuV/m)	Limit (dBuV/m)	Margin (dB)	Detector	Height (cm)	Azimuth (deg)	P/F
1	5700.00	7.41	99.43	106.84	200.00	-93.16	Average	110	53	P
2	5700.00	7.41	109.15	116.56	200.00	-83.44	Peak	110	53	P
3	5725.00	7.39	56.56	63.95	68.20	-4.25	Peak	110	53	P
4	11400.00	16.59	29.51	46.10	54.00	-7.90	Average	100	156	P
5	11400.00	16.59	42.51	59.10	74.00	-14.90	Peak	100	156	P
6	17100.00	23.97	41.16	65.13	68.20	-3.07	Peak	100	224	P

Note: Level=Reading+Factor  
Margin=Level-Limit  
Factor=Antenna Factor + cable loss - Amplifier Factor



Test Mode : 2TX 11a CH140 6Mbps  
Voltage : From Adapter(AC120V/60Hz)  
Pol : Horizontal

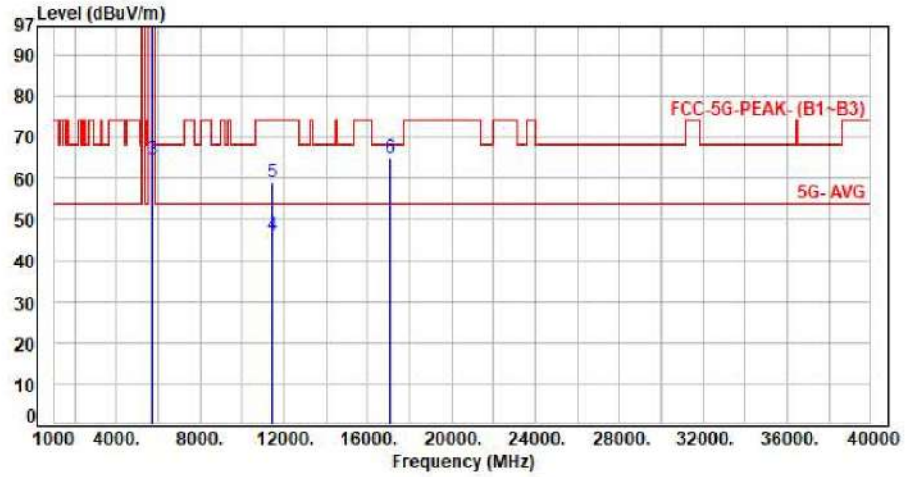

No.	Frequency (MHz)	Factor (dB)	Reading (dBuV)	Level (dBuV/m)	Limit (dBuV/m)	Margin (dB)	Detector	Height (cm)	Azimuth (deg)	P/F
1	5700.00	7.41	89.72	97.13	200.00	-102.87	Average	109	5	P
2	5700.00	7.41	99.25	106.66	200.00	-93.34	Peak	109	5	P
3	5725.00	7.39	57.18	64.57	68.20	-3.63	Peak	109	5	P
4	11400.00	16.59	29.65	46.24	54.00	-7.76	Average	100	27	P
5	11400.00	16.59	42.45	59.04	74.00	-14.96	Peak	100	27	P
6	17100.00	23.97	40.92	64.89	68.20	-3.31	Peak	100	148	P

Note: Level=Reading+Factor  
Margin=Level-Limit  
Factor=Antenna Factor + cable loss - Amplifier Factor



Test Mode : 2TX 11be EHT20 CH100 NSS1 MCS0  
 Voltage : From Adapter(AC120V/60Hz)  
 Pol : Vertical

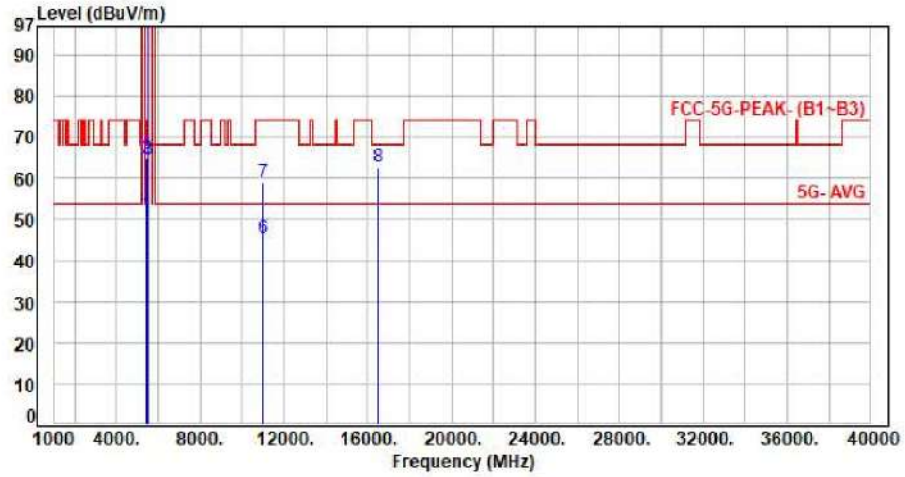

No.	Frequency (MHz)	Factor (dB)	Reading (dBuV)	Level (dBuV/m)	Limit (dBuV/m)	Margin (dB)	Detector	Height (cm)	Azimuth (deg)	P/F
1	5460.00	7.72	43.46	51.18	54.00	-2.82	Average	105	53	P
2	5460.00	7.72	57.16	64.88	74.00	-9.12	Peak	105	53	P
3	5470.00	7.72	56.90	64.62	68.20	-3.58	Peak	105	53	P
4	5500.00	7.73	99.91	107.64	200.00	-92.36	Average	105	53	P
5	5500.00	7.73	112.27	120.00	200.00	-80.00	Peak	105	53	P
6	11000.00	15.79	29.68	45.47	54.00	-8.53	Average	100	152	P
7	11000.00	15.79	43.24	59.03	74.00	-14.97	Peak	100	152	P
8	16500.00	20.93	41.69	62.62	68.20	-5.58	Peak	100	228	P

Note: Level=Reading+Factor  
 Margin=Level-Limit  
 Factor=Antenna Factor + cable loss - Amplifier Factor



Test Mode : 2TX 11be EHT20 CH100 NSS1 MCS0  
Voltage : From Adapter(AC120V/60Hz)  
Pol : Horizontal

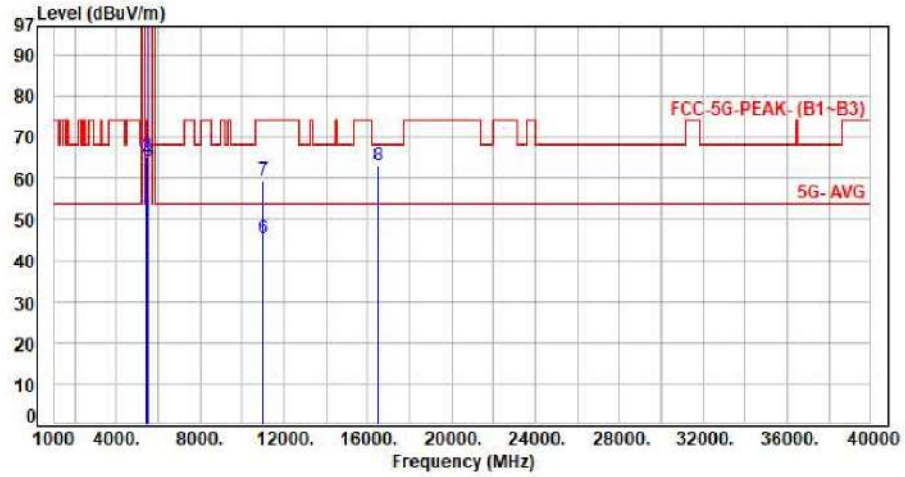

No.	Frequency (MHz)	Factor (dB)	Reading (dBuV)	Level (dBuV/m)	Limit (dBuV/m)	Margin (dB)	Detector	Height (cm)	Azimuth (deg)	P/F
1	5460.00	7.72	43.17	50.89	54.00	-3.11	Average	112	40	P
2	5460.00	7.72	57.38	65.10	74.00	-8.90	Peak	112	40	P
3	5470.00	7.72	56.60	64.32	68.20	-3.88	Peak	112	40	P
4	5500.00	7.73	89.64	97.37	200.00	-102.63	Average	112	40	P
5	5500.00	7.73	103.12	110.85	200.00	-89.15	Peak	112	40	P
6	11000.00	15.79	29.58	45.37	54.00	-8.63	Average	100	28	P
7	11000.00	15.79	43.43	59.22	74.00	-14.78	Peak	100	28	P
8	16500.00	20.93	42.14	63.07	68.20	-5.13	Peak	100	149	P

Note: Level=Reading+Factor  
Margin=Level-Limit  
Factor=Antenna Factor + cable loss - Amplifier Factor



Test Mode : 2TX 11be EHT20 CH120 NSS1 MCS0  
Voltage : From Adapter(AC120V/60Hz)  
Pol : Vertical

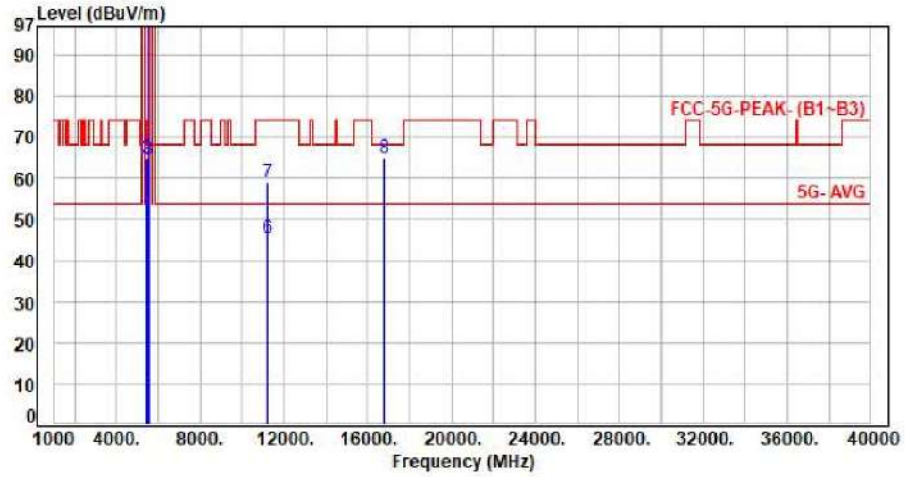

No.	Frequency (MHz)	Factor (dB)	Reading (dBuV)	Level (dBuV/m)	Limit (dBuV/m)	Margin (dB)	Detector	Height (cm)	Azimuth (deg)	P/F
1	5460.00	7.72	43.25	50.97	54.00	-3.03	Average	115	54	P
2	5460.00	7.72	57.05	64.77	74.00	-9.23	Peak	115	54	P
3	5470.00	7.72	56.87	64.59	68.20	-3.61	Peak	115	54	P
4	5600.00	7.47	99.79	107.26	200.00	-92.74	Average	115	54	P
5	5600.00	7.47	111.97	119.44	200.00	-80.56	Peak	115	54	P
6	11200.00	16.18	29.02	45.20	54.00	-8.80	Average	100	157	P
7	11200.00	16.18	42.79	58.97	74.00	-15.03	Peak	100	157	P
8	16800.00	22.69	42.29	64.98	68.20	-3.22	Peak	100	225	P

Note: Level=Reading+Factor  
Margin=Level-Limit  
Factor=Antenna Factor + cable loss - Amplifier Factor



Test Mode : 2TX 11be EHT20 CH120 NSS1 MCS0  
 Voltage : From Adapter(AC120V/60Hz)  
 Pol : Horizontal

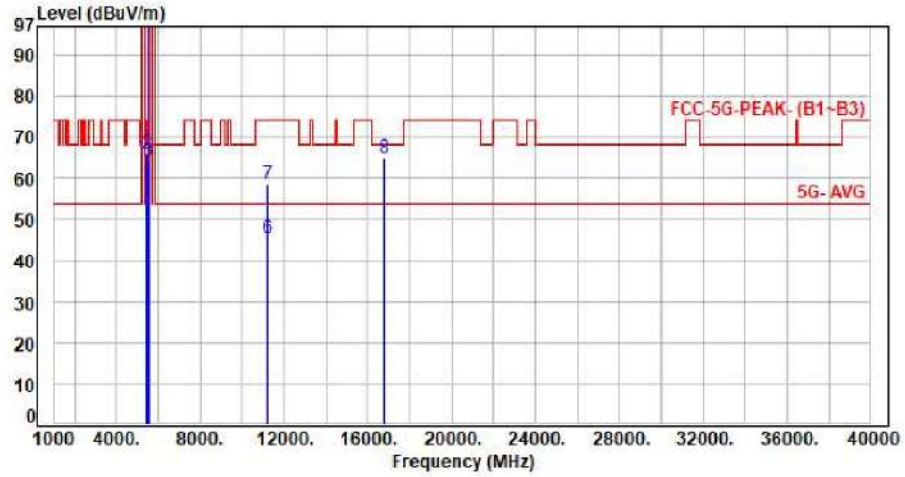

No.	Frequency (MHz)	Factor (dB)	Reading (dBuV)	Level (dBuV/m)	Limit (dBuV/m)	Margin (dB)	Detector	Height (cm)	Azimuth (deg)	P/F
1	5460.00	7.72	43.17	50.89	54.00	-3.11	Average	102	43	P
2	5460.00	7.72	58.36	66.08	74.00	-7.92	Peak	102	43	P
3	5470.00	7.72	56.53	64.25	68.20	-3.95	Peak	102	43	P
4	5600.00	7.47	89.06	96.53	200.00	-103.47	Average	102	43	P
5	5600.00	7.47	101.28	108.75	200.00	-91.25	Peak	102	43	P
6	11200.00	16.18	29.08	45.26	54.00	-8.74	Average	100	31	P
7	11200.00	16.18	42.38	58.56	74.00	-15.44	Peak	100	31	P
8	16800.00	22.69	42.17	64.86	68.20	-3.34	Peak	100	148	P

Note: Level=Reading+Factor  
 Margin=Level-Limit  
 Factor=Antenna Factor + cable loss - Amplifier Factor



Test Mode : 2TX 11be EHT20 CH140 NSS1 MCS0  
 Voltage : From Adapter(AC120V/60Hz)  
 Pol : Vertical

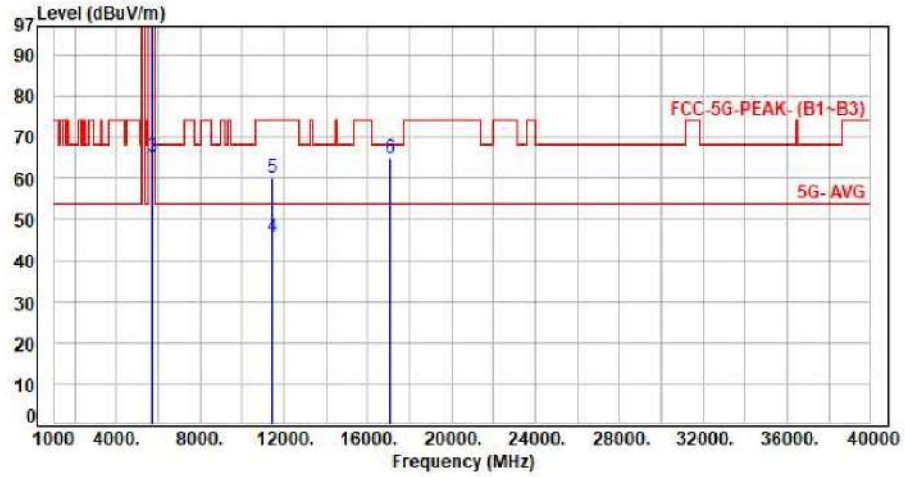

No.	Frequency (MHz)	Factor (dB)	Reading (dBuV)	Level (dBuV/m)	Limit (dBuV/m)	Margin (dB)	Detector	Height (cm)	Azimuth (deg)	P/F
1	5700.00	7.41	99.39	106.80	200.00	-93.20	Average	109	56	P
2	5700.00	7.41	111.42	118.83	200.00	-81.17	Peak	109	56	P
3	5725.00	7.39	57.93	65.32	68.20	-2.88	Peak	109	56	P
4	11400.00	16.59	29.25	45.84	54.00	-8.16	Average	100	154	P
5	11400.00	16.59	43.46	60.05	74.00	-13.95	Peak	100	154	P
6	17100.00	23.97	40.88	64.85	68.20	-3.35	Peak	100	229	P

Note: Level=Reading+Factor  
 Margin=Level-Limit  
 Factor=Antenna Factor + cable loss - Amplifier Factor



Test Mode : 2TX 11be EHT20 CH140 NSS1 MCS0  
Voltage : From Adapter(AC120V/60Hz)  
Pol : Horizontal

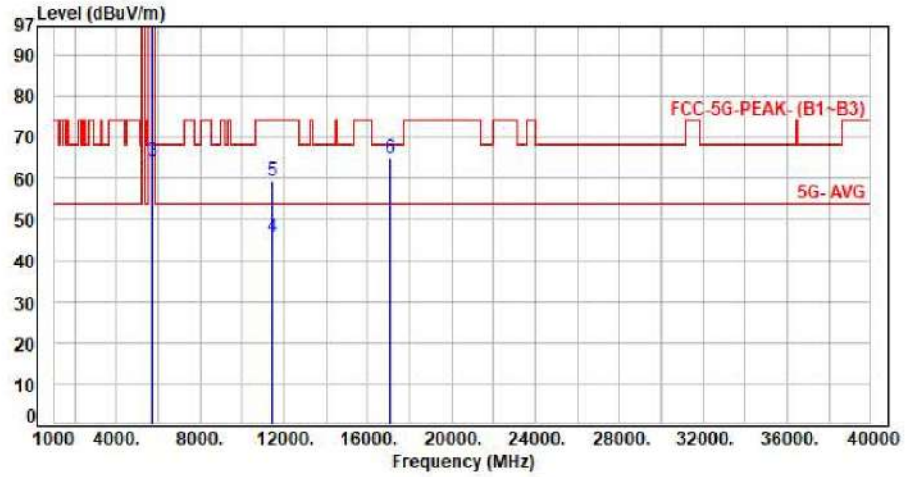

No.	Frequency (MHz)	Factor (dB)	Reading (dBuV)	Level (dBuV/m)	Limit (dBuV/m)	Margin (dB)	Detector	Height (cm)	Azimuth (deg)	P/F
1	5700.00	7.41	89.93	97.34	200.00	-102.66	Average	110	22	P
2	5700.00	7.41	101.76	109.17	200.00	-90.83	Peak	110	22	P
3	5725.00	7.39	56.85	64.24	68.20	-3.96	Peak	110	22	P
4	11400.00	16.59	29.15	45.74	54.00	-8.26	Average	100	27	P
5	11400.00	16.59	42.64	59.23	74.00	-14.77	Peak	100	27	P
6	17100.00	23.97	40.90	64.87	68.20	-3.33	Peak	100	142	P

Note: Level=Reading+Factor  
Margin=Level-Limit  
Factor=Antenna Factor + cable loss - Amplifier Factor



Test Mode : 2TX 11be EHT40 CH102 NSS1 MCS0  
Voltage : From Adapter(AC120V/60Hz)  
Pol : Vertical

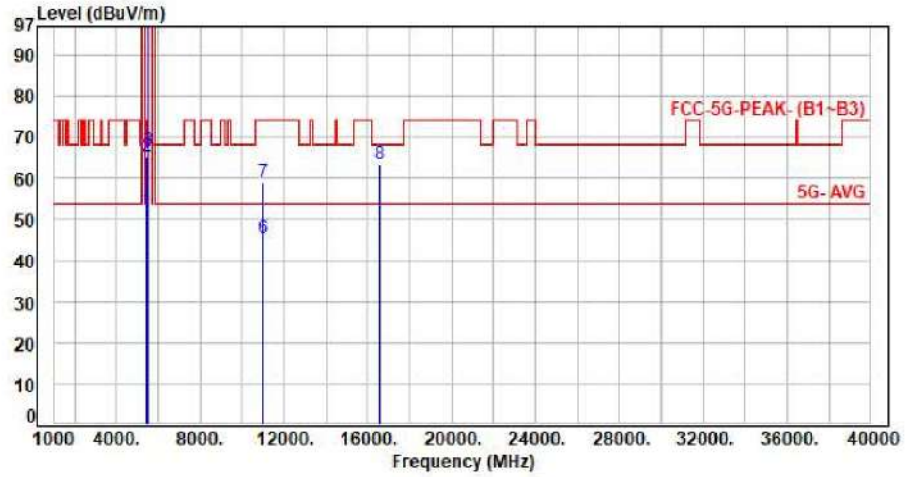

No.	Frequency (MHz)	Factor (dB)	Reading (dBuV)	Level (dBuV/m)	Limit (dBuV/m)	Margin (dB)	Detector	Height (cm)	Azimuth (deg)	P/F
1	5460.00	7.72	44.24	51.96	54.00	-2.04	Average	115	52	P
2	5460.00	7.72	57.69	65.41	74.00	-8.59	Peak	115	52	P
3	5470.00	7.72	59.21	66.93	68.20	-1.27	Peak	115	52	P
4	5510.00	7.70	97.99	105.69	200.00	-94.31	Average	115	52	P
5	5510.00	7.70	110.89	118.59	200.00	-81.41	Peak	115	52	P
6	11020.00	15.82	29.39	45.21	54.00	-8.79	Average	100	153	P
7	11020.00	15.82	43.29	59.11	74.00	-14.89	Peak	100	153	P
8	16530.00	20.97	42.46	63.43	68.20	-4.77	Peak	100	226	P

Note: Level=Reading+Factor  
Margin=Level-Limit  
Factor=Antenna Factor + cable loss - Amplifier Factor



Test Mode : 2TX 11be EHT40 CH102 NSS1 MCS0  
Voltage : From Adapter(AC120V/60Hz)  
Pol : Horizontal

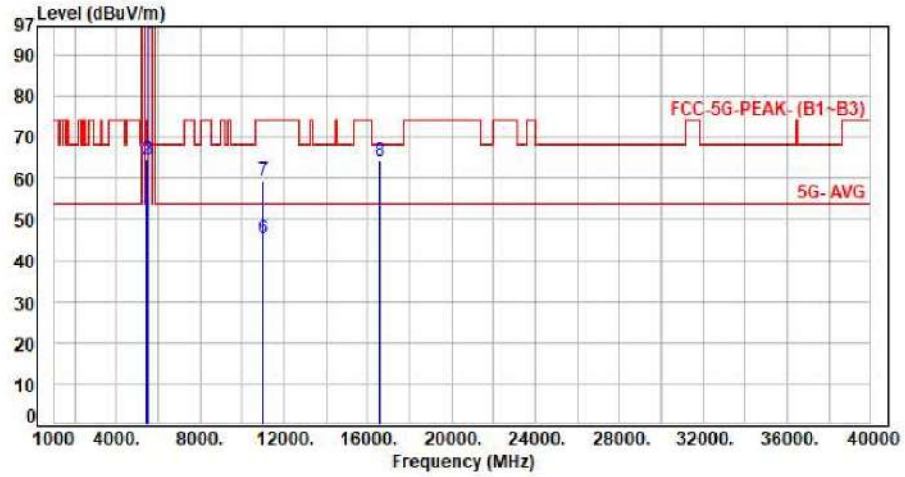

No.	Frequency (MHz)	Factor (dB)	Reading (dBuV)	Level (dBuV/m)	Limit (dBuV/m)	Margin (dB)	Detector	Height (cm)	Azimuth (deg)	P/F
1	5460.00	7.72	43.11	50.83	54.00	-3.17	Average	100	39	P
2	5460.00	7.72	56.77	64.49	74.00	-9.51	Peak	100	39	P
3	5470.00	7.72	56.81	64.53	68.20	-3.67	Peak	100	39	P
4	5510.00	7.70	87.49	95.19	200.00	-104.81	Average	100	39	P
5	5510.00	7.70	100.46	108.16	200.00	-91.84	Peak	100	39	P
6	11020.00	15.82	29.53	45.35	54.00	-8.65	Average	100	29	P
7	11020.00	15.82	43.64	59.46	74.00	-14.54	Peak	100	29	P
8	16530.00	20.97	43.11	64.08	68.20	-4.12	Peak	100	146	P

Note: Level=Reading+Factor  
Margin=Level-Limit  
Factor=Antenna Factor + cable loss - Amplifier Factor



Test Mode : 2TX 11be EHT40 CH118 NSS1 MCS0  
 Voltage : From Adapter(AC120V/60Hz)  
 Pol : Vertical

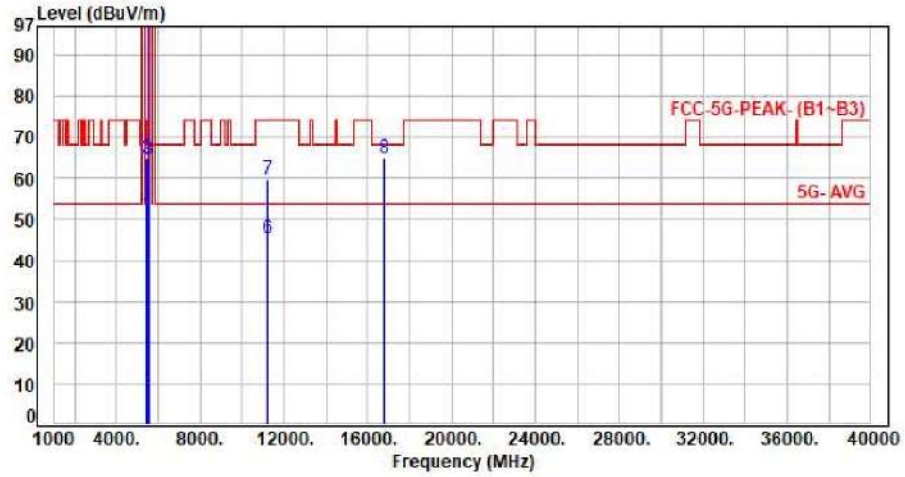

No.	Frequency (MHz)	Factor (dB)	Reading (dBuV)	Level (dBuV/m)	Limit (dBuV/m)	Margin (dB)	Detector	Height (cm)	Azimuth (deg)	P/F
1	5460.00	7.72	43.52	51.24	54.00	-2.76	Average	111	53	P
2	5460.00	7.72	57.09	64.81	74.00	-9.19	Peak	111	53	P
3	5470.00	7.72	56.86	64.58	68.20	-3.62	Peak	111	53	P
4	5590.00	7.49	98.54	106.03	200.00	-93.97	Average	111	53	P
5	5590.00	7.49	110.79	118.28	200.00	-81.72	Peak	111	53	P
6	11180.00	16.11	29.09	45.20	54.00	-8.80	Average	100	154	P
7	11180.00	16.11	43.46	59.57	74.00	-14.43	Peak	100	154	P
8	16770.00	22.45	42.34	64.79	68.20	-3.41	Peak	100	228	P

Note: Level=Reading+Factor  
 Margin=Level-Limit  
 Factor=Antenna Factor + cable loss - Amplifier Factor



Test Mode : 2TX 11be EHT40 CH118 NSS1 MCS0  
 Voltage : From Adapter(AC120V/60Hz)  
 Pol : Horizontal

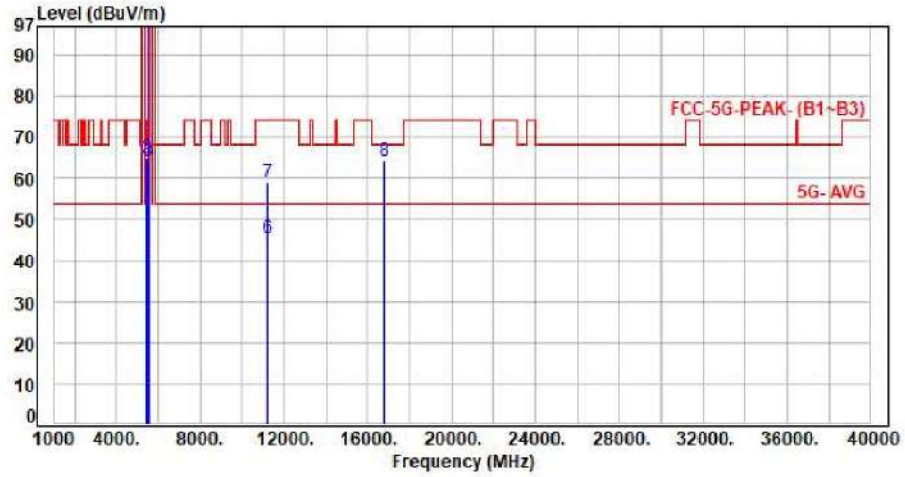

No.	Frequency (MHz)	Factor (dB)	Reading (dBuV)	Level (dBuV/m)	Limit (dBuV/m)	Margin (dB)	Detector	Height (cm)	Azimuth (deg)	P/F
1	5460.00	7.72	43.10	50.82	54.00	-3.18	Average	112	35	P
2	5460.00	7.72	57.18	64.90	74.00	-9.10	Peak	112	35	P
3	5470.00	7.72	56.57	64.29	68.20	-3.91	Peak	112	35	P
4	5590.00	7.49	89.32	96.81	200.00	-103.19	Average	112	35	P
5	5590.00	7.49	101.77	109.26	200.00	-90.74	Peak	112	35	P
6	11180.00	16.11	29.37	45.48	54.00	-8.52	Average	100	25	P
7	11180.00	16.11	42.80	58.91	74.00	-15.09	Peak	100	25	P
8	16770.00	22.45	41.78	64.23	68.20	-3.97	Peak	100	147	P

Note: Level=Reading+Factor  
 Margin=Level-Limit  
 Factor=Antenna Factor + cable loss - Amplifier Factor



Test Mode : 2TX 11be EHT40 CH134 NSS1 MCS0  
Voltage : From Adapter(AC120V/60Hz)  
Pol : Vertical

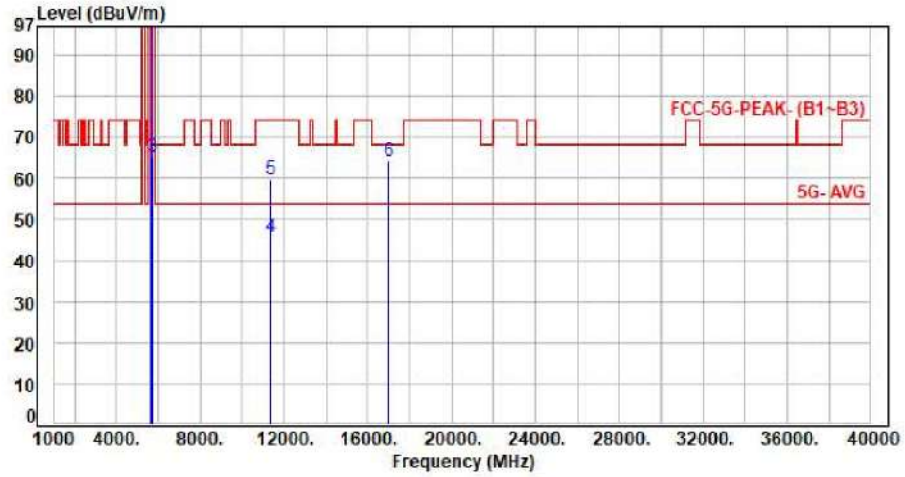

No.	Frequency (MHz)	Factor (dB)	Reading (dBuV)	Level (dBuV/m)	Limit (dBuV/m)	Margin (dB)	Detector	Height (cm)	Azimuth (deg)	P/F
1	5670.00	7.48	99.52	107.00	200.00	-93.00	Average	100	55	P
2	5670.00	7.48	112.22	119.70	200.00	-80.30	Peak	100	55	P
3	5725.00	7.39	57.72	65.11	68.20	-3.09	Peak	100	55	P
4	11340.00	16.42	29.41	45.83	54.00	-8.17	Average	100	155	P
5	11340.00	16.42	43.15	59.57	74.00	-14.43	Peak	100	155	P
6	17010.00	23.73	40.44	64.17	68.20	-4.03	Peak	100	229	P

Note: Level=Reading+Factor  
Margin=Level-Limit  
Factor=Antenna Factor + cable loss - Amplifier Factor



Test Mode : 2TX 11be EHT40 CH134 NSS1 MCS0  
Voltage : From Adapter(AC120V/60Hz)  
Pol : Horizontal

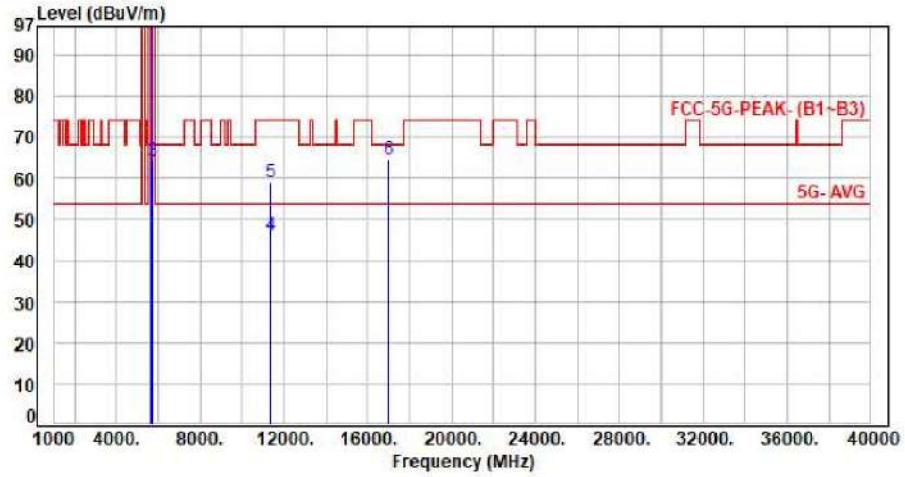

No.	Frequency (MHz)	Factor (dB)	Reading (dBuV)	Level (dBuV/m)	Limit (dBuV/m)	Margin (dB)	Detector	Height (cm)	Azimuth (deg)	P/F
1	5670.00	7.48	90.54	98.02	200.00	-101.98	Average	100	5	P
2	5670.00	7.48	102.36	109.84	200.00	-90.16	Peak	100	5	P
3	5725.00	7.39	56.92	64.31	68.20	-3.89	Peak	100	5	P
4	11340.00	16.42	29.78	46.20	54.00	-7.80	Average	100	28	P
5	11340.00	16.42	42.69	59.11	74.00	-14.89	Peak	100	28	P
6	17010.00	23.73	40.89	64.62	68.20	-3.58	Peak	100	146	P

Note: Level=Reading+Factor  
Margin=Level-Limit  
Factor=Antenna Factor + cable loss - Amplifier Factor